

## COMPREHENSIVE SERVICES

We offer competitive repair and calibration services, as well as easily accessible documentation and free downloadable resources.

## SELL YOUR SURPLUS

We buy new, used, decommissioned, and surplus parts from every NI series. We work out the best solution to suit your individual needs.

 Sell For Cash    Get Credit    Receive a Trade-In Deal

## OBSOLETE NI HARDWARE IN STOCK & READY TO SHIP

We stock **New**, **New Surplus**, **Refurbished**, and **Reconditioned** NI Hardware.



*Bridging the gap between the manufacturer and your legacy test system.*

 1-800-915-6216

 [www.apexwaves.com](http://www.apexwaves.com)

 [sales@apexwaves.com](mailto:sales@apexwaves.com)

*All trademarks, brands, and brand names are the property of their respective owners.*

**Request a Quote**

 **CLICK HERE**

**PXI-6624**

# NI 6624 Calibration Procedure

[Français](#)   [Deutsch](#)   [日本語](#)   [한국어](#)   [简体中文](#)

[ni.com/manuals](http://ni.com/manuals)

This document contains information for calibrating the National Instruments 6624 counter/timer device. For more information about calibration, visit [ni.com/calibration](http://ni.com/calibration).

## Contents

---

Conventions .....	2
Software Requirements .....	2
Documentation Requirements .....	2
Calibration Interval .....	3
Test Equipment .....	3
Test Conditions .....	4
Device Pinout .....	5
Calibration Process .....	6
Initial Setup .....	7
Verification .....	8
Where to Go for Support.....	9

# Conventions

---



The following conventions are used in this document:

This icon denotes a note, which alerts you to important information.

*italic*

Italic text denotes variables, emphasis, a cross-reference, or an introduction to a key concept. Italic text also denotes text that is a placeholder for a word or value that you must supply.

monospace

Text in this font denotes text or characters that you should enter from the keyboard, sections of code, programming examples, and syntax examples. This font is also used for the proper names of disk drives, paths, directories, programs, subprograms, subroutines, device names, functions, operations, variables, filenames, and extensions.

## Software Requirements

---

Calibrating the NI 6624 requires installing NI-DAQmx 7.5 or later on the calibration system. You can download NI-DAQmx at [ni.com/downloads](http://ni.com/downloads). NI-DAQmx supports programming an External Calibration in the LabVIEW, LabWindows™/CVI™, Microsoft Visual C++ 6.0, Microsoft Visual Basic 6.0, Microsoft .NET, and Borland C++ application development environments (ADEs). When you install NI-DAQmx, you only need to install support for the ADE that you intend to use.



**Note** NI recommends that you install the NI-DAQmx driver software before installing the NI 6624 device.

## Documentation Requirements

---

For information about NI-DAQmx and the NI 6624, you can consult the following documents:

- *NI-DAQmx Help*—This help file contains general information about measurement concepts, key NI-DAQmx concepts, and common applications that apply to all programming environments.
- *NI-DAQmx C Reference Help*—This help file contains C reference and general information about measurement concepts.
- *DAQ Getting Started* guides—These guides describe how to install NI-DAQmx for Windows software and NI-DAQmx-supported DAQ devices, and how to confirm that your device is operating properly.

- *NI 6624 User Manual*—This document describes the electrical and mechanical aspects of the NI 6624 and contains information about its operation and programming.
- *NI 6624 Specifications*—This document lists the specifications for the NI 6624. The limits you use to verify the accuracy of the device are based on the specifications found in this document. You can download the latest version of this document from the NI Web site at [ni.com/manuals](http://ni.com/manuals).

These documents are installed with NI-DAQmx. You can also find the latest versions of the documentation at [ni.com/manuals](http://ni.com/manuals).

## Calibration Interval

---

NI recommends that you perform a complete calibration at least once every year. You can shorten this interval based on the accuracy requirements of your application.

## Test Equipment

---

NI recommends that you use the equipment in Table 1 for calibrating the NI 6624.

**Table 1.** Recommended Equipment

Equipment	Recommended Model	Minimum Requirements
External Counter	PXI-6608	≤1 ppm uncertainty for measurement
+5 V Power Source	—	Must be able to source current of at least 1 A.
Discrete Resistors	—	5% precision Resistor values: 500 Ω (× 2)
Cable	SH100-100-F	—
Connector Block	SCB-100	—



**Note** You also need a CompactPCI-to-PCI adapter if you are calibrating the PXI-6624.

# Test Conditions

---

Follow these guidelines to optimize the equipment and the environment during calibration:

- Keep connections to the device as short as possible. Long cables and wires act as antennae, picking up extra noise that can affect measurements.
- Verify that all connections to the device, including front panel connections, are secure.
- Maintain an ambient temperature of 25 °C. The device temperature will be greater than the ambient temperature.
- Keep relative humidity below 80%.
- Allow a warm up time of at least 15 minutes to ensure that the measurement circuitry is at a stable operating temperature.
- Use shielded copper wire for all cable connections to the device. Use twisted-pairs wire to eliminate noise and thermal offsets.
- Ensure that the PXI chassis fan speed is set to HIGH, that the fan filters are clean, and that the empty slots contain filler panels. For more information, refer to the *Maintain Forced-Air Cooling Note to Users* document available at [ni.com/manuals](http://ni.com/manuals).
- Plug the chassis and the instrument into the same power strip to avoid ground loops.

# Device Pinout

Figure 1 shows the pinout of the NI 6624.

PFI 39 +/CTR 0 SOURCE +	1	51	PFI 23 +/CTR 4 SOURCE +
PFI 39 -/CTR 0 SOURCE -	2	52	PFI 23 -/CTR 4 SOURCE -
PFI 38 +/CTR 0 GATE +	3	53	PFI 22 +/CTR 4 GATE +
PFI 38 -/CTR 0 GATE -	4	54	PFI 22 -/CTR 4 GATE -
PFI 37 +/CTR 0 AUX+	5	55	PFI 21 +/CTR 4 AUX +
PFI 37 -/CTR 0 AUX-	6	56	PFI 21 -/CTR 4 AUX -
PFI 36 Vdd/CTR 0 Vdd	7	57	PFI 20 Vdd/CTR 4 Vdd
PFI 36 Vss/CTR 0 Vss	8	58	PFI 20 Vss/CTR 4 Vss
PFI 36/CTR 0 OUT	9	59	PFI 20/CTR 4 OUT
PFI 36 Vss/CTR 0 Vss	10	60	PFI 20 Vss/CTR 4 Vss
PFI 35 +/CTR 1 SOURCE +	11	61	PFI 19 +/CTR 5 SOURCE +
PFI 35 -/CTR 1 SOURCE -	12	62	PFI 19 -/CTR 5 SOURCE -
PFI 34 +/CTR 1 GATE +	13	63	PFI 18 +/CTR 5 GATE +
PFI 34 -/CTR 1 GATE -	14	64	PFI 18 -/CTR 5 GATE -
PFI 33 +/CTR 1 AUX +	15	65	PFI 17 +/CTR 5 AUX +
PFI 33 -/CTR 1 AUX -	16	66	PFI 17 -/CTR 5 AUX -
PFI 32 Vdd/CTR 1 Vdd	17	67	PFI 16 Vdd/CTR 5 Vdd
PFI 32 Vss/CTR 1 Vss	18	68	PFI 16 Vss/CTR 5 Vss
PFI 32/CTR 1 OUT	19	69	PFI 16/CTR 5 OUT
PFI 32 Vss/CTR 1 Vss	20	70	PFI 16 Vss/CTR 5 Vss
PFI 31 +/CTR 2 SOURCE +	21	71	PFI 15 +/CTR 6 SOURCE +
PFI 31 -/CTR 2 SOURCE -	22	72	PFI 15 -/CTR 6 SOURCE -
PFI 30 +/CTR 2 GATE +	23	73	PFI 14 +/CTR 6 GATE +
PFI 30 -/CTR 2 GATE -	24	74	PFI 14 -/CTR 6 GATE -
PFI 29 +/CTR 2 AUX +	25	75	PFI 13 +/CTR 6 AUX +
PFI 29 -/CTR 2 AUX -	26	76	PFI 13 -/CTR 6 AUX -
PFI 28 Vdd/CTR 2 Vdd	27	77	PFI 12 Vdd/CTR 6 Vdd
PFI 28 Vss/CTR 2 Vss	28	78	PFI 12 Vss/CTR 6 Vss
PFI 28/CTR 2 OUT	29	79	PFI 12/CTR 6 OUT
PFI 28 Vss/CTR 2 Vss	30	80	PFI 12 Vss/CTR 6 Vss
PFI 27 +/CTR 3 SOURCE +	31	81	PFI 11 +/CTR 7 SOURCE +
PFI 27 -/CTR 3 SOURCE -	32	82	PFI 11 -/CTR 7 SOURCE -
PFI 26 +/CTR 3 GATE +	33	83	PFI 10 +/CTR 7 GATE +
PFI 26 -/CTR 3 GATE -	34	84	PFI 10 -/CTR 7 GATE -
PFI 25 +/CTR 3 AUX +	35	85	PFI 9 +/CTR 7 AUX +
PFI 25 -/CTR 3 AUX -	36	86	PFI 9 -/CTR 7 AUX -
PFI 24 Vdd/CTR 3 Vdd	37	87	PFI 8 Vdd/CTR 7 Vdd
PFI 24 Vss/CTR 3 Vss	38	88	PFI 8 Vss/CTR 7 Vss
PFI 24/CTR 3 OUT	39	89	PFI 8/CTR 7 OUT
PFI 24 Vss/CTR 3 Vss	40	90	PFI 8 Vss/CTR 7 Vss
PFI 0 +	41	91	PFI 4 +
PFI 0 -	42	92	PFI 4 -
NC	43	93	NC
NC	44	94	NC
NC	45	95	NC
NC	46	96	NC
NC	47	97	NC
NC	48	98	NC
NC	49	99	NC
NC	50	100	NC

NC = No Connect

Figure 1. NI 6624 Pinout

# Calibration Process

When calibrating the NI 6624, you first use the 20 MHz timebase on the NI 6624 as the source to generate a 1 Hz square wave signal. The external counter measures the frequency of the square wave signal. You then calculate the frequency of the crystal oscillator to determine if the NI 6624 is operating within its specifications. Figure 2 illustrates the calibration process.

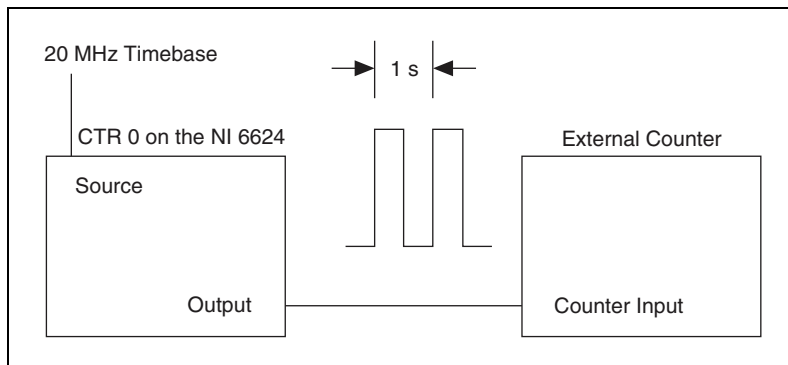

**Figure 2.** NI 6624 Calibration Process

The frequency measurement has an uncertainty that is equal to the sum of the propagation delay of the NI 6624 and the error of the external counter. The maximum propagation delay is 500 ns. Using a measurement duration of 1 s, the propagation delay uncertainty can be calculated as follows:

$$\frac{500 \text{ ns}}{1 \text{ s}} = 0.5 \text{ ppm}$$

The error of the external counter must be 1 ppm or less, as specified in the [Test Equipment](#) section of this document. The measurement uncertainty equals the sum of 0.5 ppm and 1 ppm, that is, 1.5 ppm. Therefore, the calculated frequency allows for a 1.5 ppm measurement uncertainty. You can reduce measurement uncertainty by using a more stable external counter, by increasing the measurement duration, or both.

The calibration process includes the following steps:

1. **Initial Setup**—Set up the test equipment for calibration.
2. **Verification**—Verify the existing operation of the device. This step confirms whether the device is operating within its specifications.

# Initial Setup

Refer to the *DAQ Getting Started* guides for information about how to install the software and hardware and how to configure the device in Measurement & Automation Explorer (MAX). NI recommends that you use the PXI-6608 to provide the external counter. You can use an alternative counter if it meets the requirements described in the [Test Equipment](#) section of this document.



**Note** If you are calibrating the PXI-6624 on a PXI chassis, the measured frequency is that of the PXI backplane clock instead of the onboard crystal oscillator. To verify the onboard crystal oscillator, you must calibrate the PXI-6624 on a PCI chassis using a CompactPCI-to-PCI adapter.

Complete the following steps to set up the test equipment for calibration:

1. Cable the NI 6624 to a 100-pin connector block.
2. Wire the +5 V power source to the connector block. Refer to Figure 3 for the calibration connections.
  - a. Wire the +5 V power terminal to the connector block terminal that is connected to the PFI 36 Vdd/CTR 0 Vdd pin (pin 7) on the NI 6624.
  - b. Wire the ground of the +5 V power source to the connector block terminal that is connected to the PFI 36 Vss/CTR 0 Vss pin (pin 8) on the NI 6624.

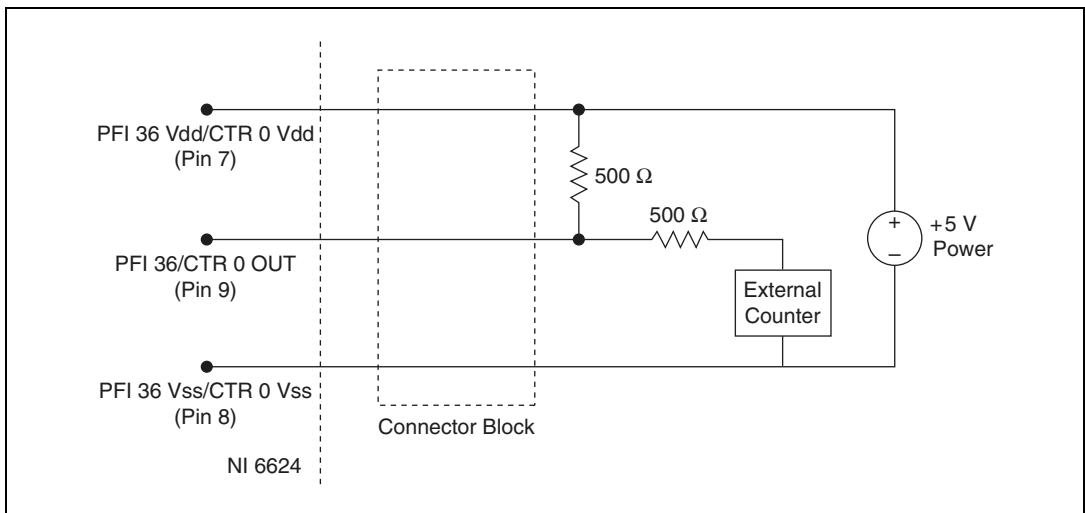

**Figure 3.** Calibration Connections



3. Wire a 500  $\Omega$  resistor between the connector block terminals that are connected to the PFI 36 Vdd/CTR 0 Vdd pin (pin 7) and PFI 36/CTR 0 OUT pin (pin 9) on the NI 6624. Wire another 500  $\Omega$  resistor to the connector block terminal that is connected to the PFI 36/CTR 0 OUT pin (pin 9) on the NI 6624, as Figure 3 shows.
4. Connect the external counter to the connector block using twisted-pair wires.
  - a. Wire the input of the external counter to the other end of the 500  $\Omega$  resistor that is connected to the PFI 36/CTR 0 OUT pin (pin 9) on the NI 6624.
  - b. Wire the ground of the external counter to the connector block terminal that is connected to the PFI 36 Vss/CTR 0 Vss pin (pin 8) on the NI 6624.

## Verification

Complete the following steps to verify the operation of the crystal oscillator on the NI 6624:

1. Configure counter 0 on the NI 6624 to generate a 1 Hz continuous square wave signal with a 50% duty cycle on the PFI 36/CTR 0 OUT pin (pin 9).
2. Measure the frequency of the generated signal using the external counter. It might take some time for the external counter to measure the 1 Hz signal.
3. Multiply the measured frequency with 20,000,000 to calculate the number of pulses that should occur in one second.
4. Compare the frequency value you calculated from the measurement result with the following values:
  - a. If the frequency you measured falls between the upper limit of 20,001,000 Hz and the lower limit of 19,999,000 Hz, your device is operating within its specifications.
  - b. If the frequency you measured is above 20,001,000 Hz or below 19,999,000 Hz, your device is nonfunctional. Return the device to NI for repair or replacement.



**Note** Limits in this document are based upon the December 2006 edition of the *NI 6624 Specifications*. Refer to the most recent NI 6624 specifications online at [ni.com/manuals](http://ni.com/manuals). If a more recent edition of the specifications is available, recalculate the limits based upon the latest specifications.

# Where to Go for Support

---

The National Instruments Web site is your complete resource for technical support. At [ni.com/support](http://ni.com/support) you have access to everything from troubleshooting and application development self-help resources to email and phone assistance from NI Application Engineers.

National Instruments corporate headquarters is located at 11500 North Mopac Expressway, Austin, Texas, 78759-3504. National Instruments also has offices located around the world to help address your support needs. For telephone support in the United States, create your service request at [ni.com/support](http://ni.com/support) and follow the calling instructions or dial 512 795 8248. For telephone support outside the United States, contact your local branch office:

Australia 1800 300 800, Austria 43 662 457990-0,  
Belgium 32 (0) 2 757 0020, Brazil 55 11 3262 3599,  
Canada 800 433 3488, China 86 21 5050 9800,  
Czech Republic 420 224 235 774, Denmark 45 45 76 26 00,  
Finland 358 (0) 9 725 72511, France 01 57 66 24 24,  
Germany 49 89 7413130, India 91 80 41190000, Israel 972 3 6393737,  
Italy 39 02 41309277, Japan 0120-527196, Korea 82 02 3451 3400,  
Lebanon 961 (0) 1 33 28 28, Malaysia 1800 887710,  
Mexico 01 800 010 0793, Netherlands 31 (0) 348 433 466,  
New Zealand 0800 553 322, Norway 47 (0) 66 90 76 60,  
Poland 48 22 328 90 10, Portugal 351 210 311 210,  
Russia 7 495 783 6851, Singapore 1800 226 5886,  
Slovenia 386 3 425 42 00, South Africa 27 0 11 805 8197,  
Spain 34 91 640 0085, Sweden 46 (0) 8 587 895 00,  
Switzerland 41 56 2005151, Taiwan 886 02 2377 2222,  
Thailand 662 278 6777, Turkey 90 212 279 3031,  
United Kingdom 44 (0) 1635 523545

CVI, National Instruments, NI, ni.com, and LabVIEW are trademarks of National Instruments Corporation. Refer to the *Terms of Use* section on [ni.com/legal](http://ni.com/legal) for more information about National Instruments trademarks. The mark LabWindows is used under a license from Microsoft Corporation. Windows is a registered trademark of Microsoft Corporation in the United States and other countries. Other product and company names mentioned herein are trademarks or trade names of their respective companies. For patents covering National Instruments products/technology, refer to the appropriate location: **Help»Patents** in your software, the `patents.txt` file on your media, or the *National Instruments Patent Notice* at [ni.com/patents](http://ni.com/patents).