

COMPREHENSIVE SERVICES

We offer competitive repair and calibration services, as well as easily accessible documentation and free downloadable resources.

SELL YOUR SURPLUS

We buy new, used, decommissioned, and surplus parts from every NI series. We work out the best solution to suit your individual needs.

 Sell For Cash  Get Credit  Receive a Trade-In Deal

OBSOLETE NI HARDWARE IN STOCK & READY TO SHIP

We stock **New**, **New Surplus**, **Refurbished**, and **Reconditioned** NI Hardware.



Bridging the gap between the manufacturer and your legacy test system.

 1-800-915-6216

 www.apexwaves.com

 sales@apexwaves.com

All trademarks, brands, and brand names are the property of their respective owners.

Request a Quote

 **CLICK HERE**

PXIe-6366

NOTE TO USERS

NI 62xx/63xx Pinout Labels for the SCB-68

Multifunction I/O M/X Series Modules/Devices Using the 68-Pin Shielded Connector Block

If you are using an NI 62xx (formerly referred to as M Series) or NI 63xx (formerly referred to as X Series) multifunction I/O device or module with the SCB-68, you can attach a connector-specific pinout label to the cover of the connector block for easy connection reference. This document provides labels for the following models:

NI 6220	NI 6320	NI 6356
NI 6221	NI 6321	NI 6358
NI 6224	NI 6323	NI 6366
NI 6225	NI 6341	NI 6368
NI 6229	NI 6343	NI 6374
NI 6250	NI 6345	NI 6376
NI 6251	NI 6351	NI 6378
NI 6254	NI 6353	
NI 6255	NI 6355	
NI 6259	NI 6361	
NI 6280	NI 6363	
NI 6281	NI 6365	
NI 6284	NI 6375	
NI 6289		

Use the following label if you are connecting the SCB-68 to Connector 0 of NI 6220/6224 and NI 6320 models.

Figure 1. NI 6220/6224 and NI 6320 Connector 0

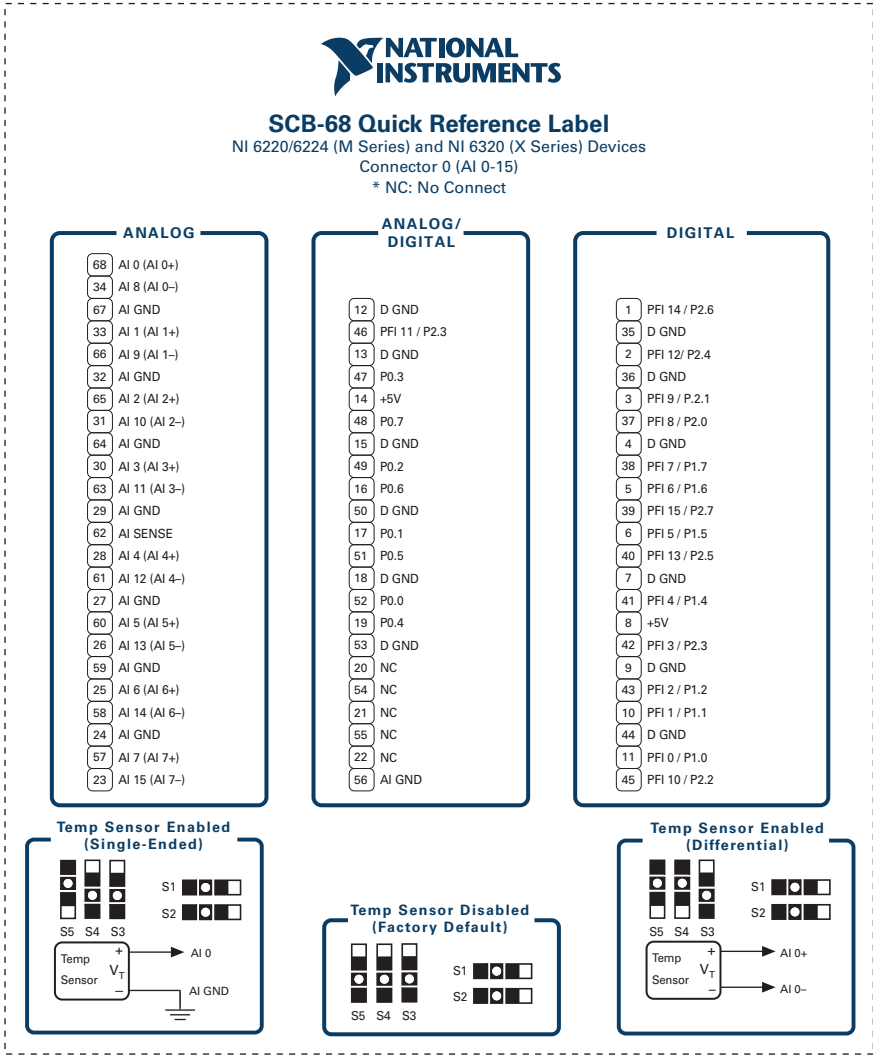

Use the following label if you are connecting the SCB-68 to Connector 0 of NI 6221/6225/6229 and NI 6321/6341/6343 models.

Figure 2. NI 6221/6225/6229 and NI 6321/6341/6343 Connector 0

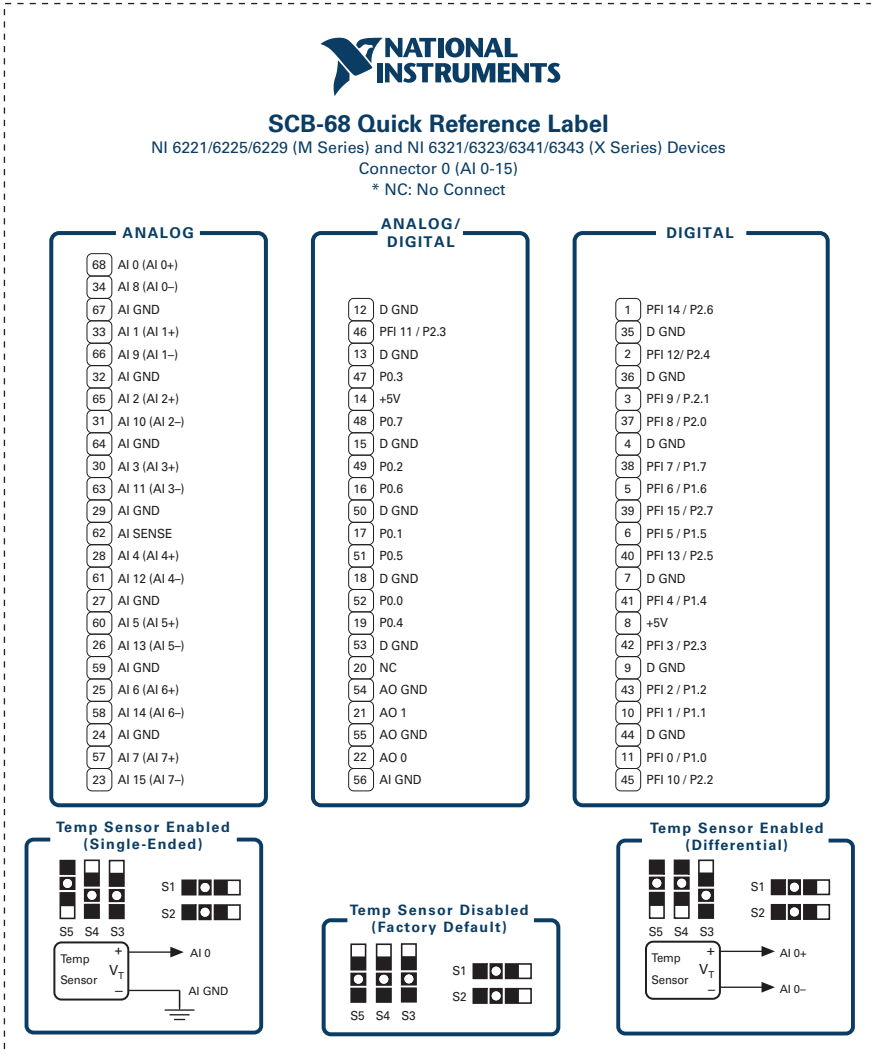

Use the following label if you are connecting the SCB-68 to Connector 0 of NI 6250/6254/6280/6284 models.

Figure 3. NI 6250/6254/6280/6284 Connector 0

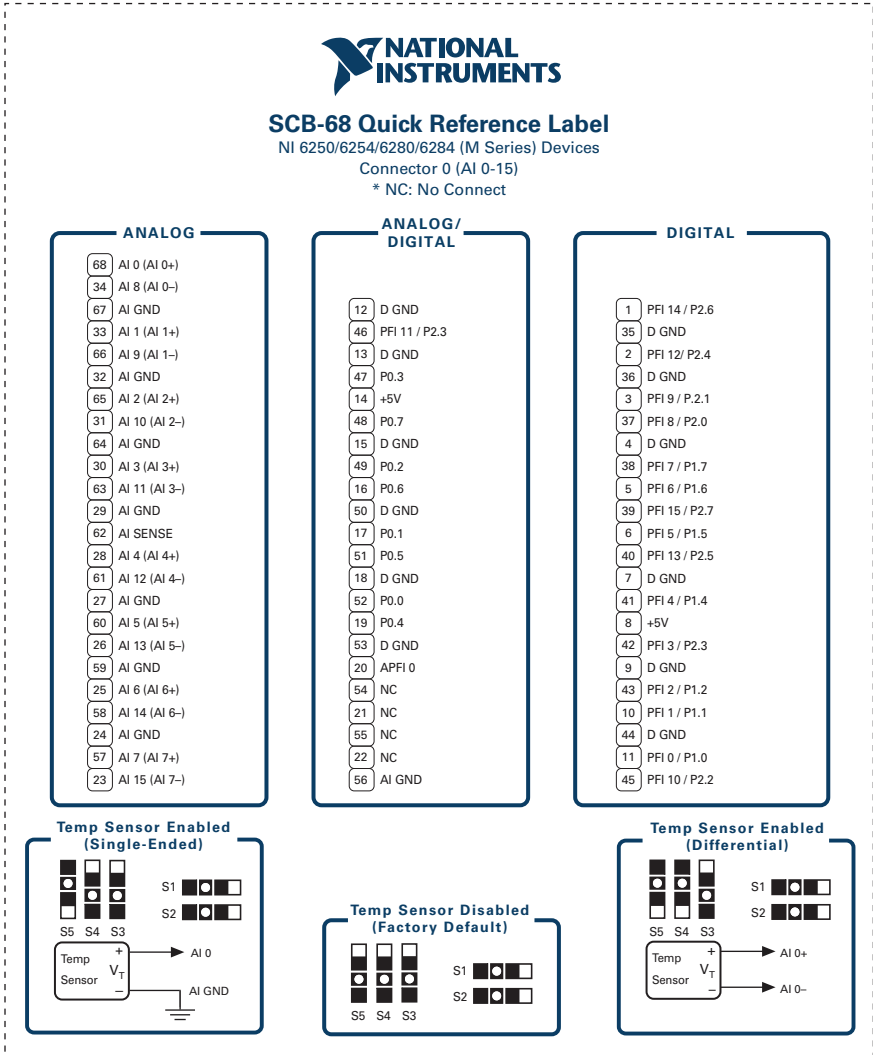

Use the following label if you are connecting the SCB-68 to Connector 0 of NI 6251/6255/6259/6281/6289 and NI 635x/636x/6375/6376/6378 models.

Figure 4. NI 6251/6255/6259/6281/6289 and NI 635x/636x/6375/6376/6378 Connector 0

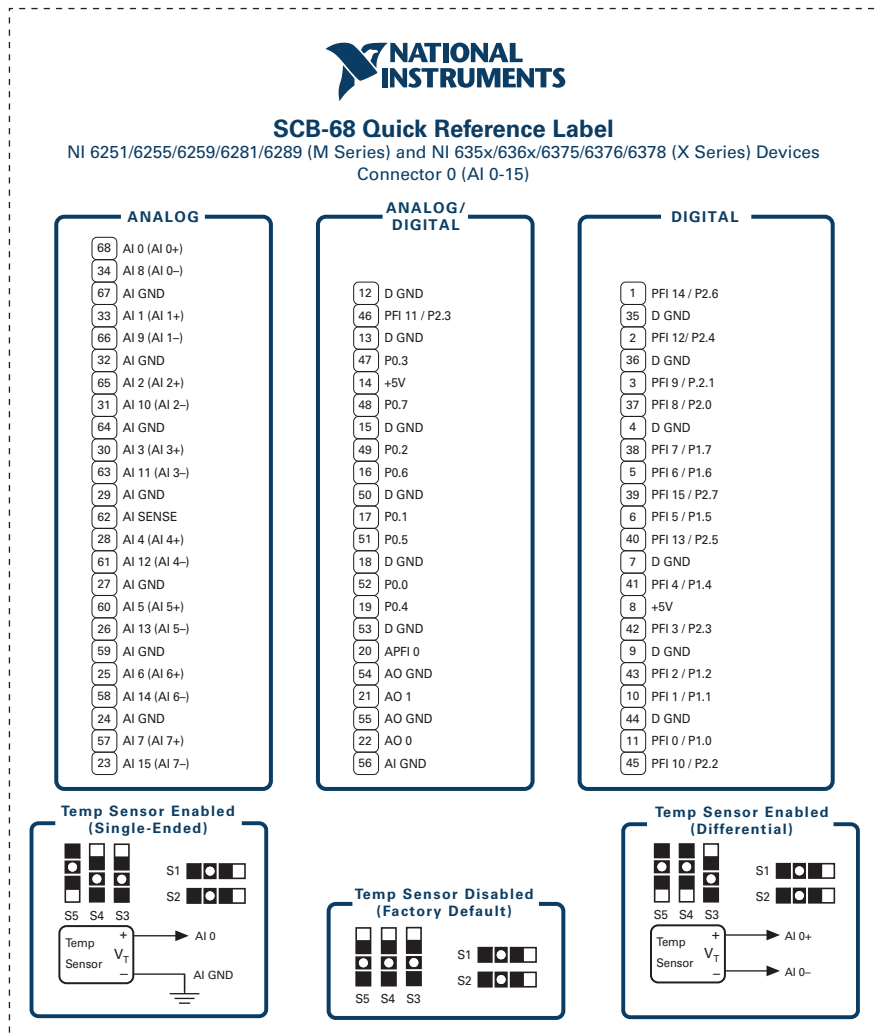

Use the following label if you are connecting the SCB-68 to Connector 0 of the NI 6374 model.

Figure 5. NI 6374 Connector 0

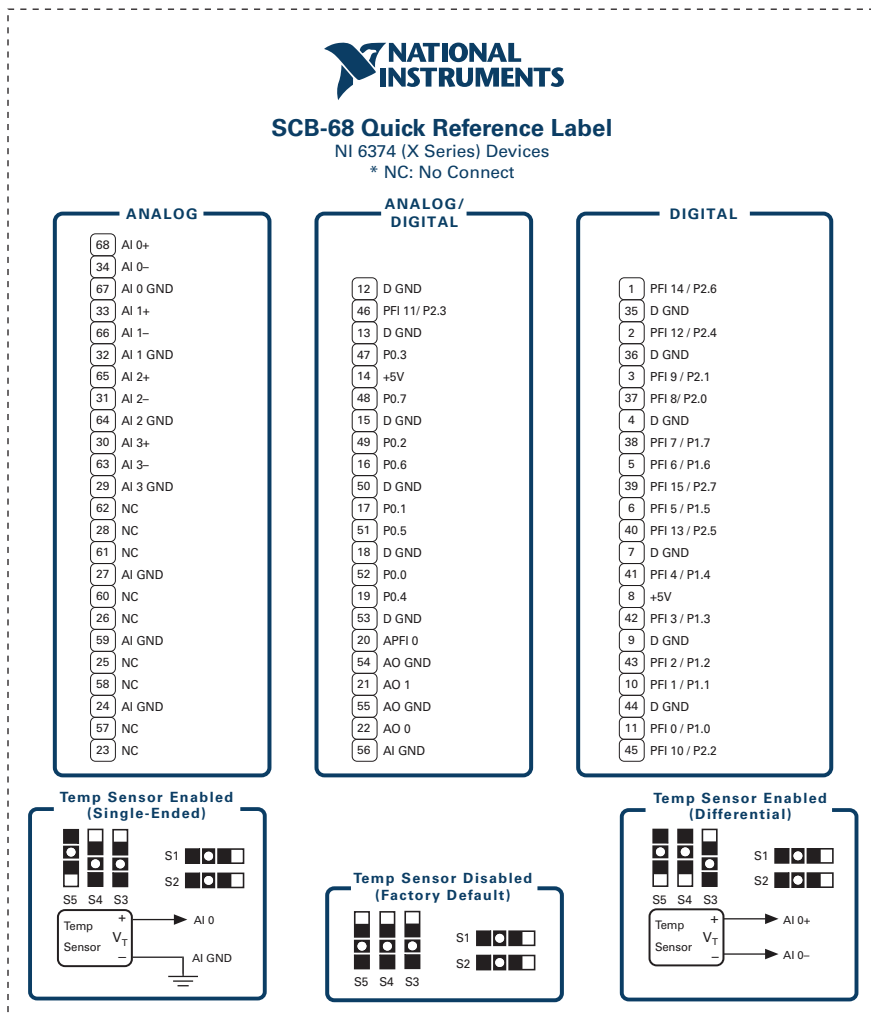

Use the following label if you are connecting the SCB-68 to Connector 1 of the NI 6224 model.

Figure 6. NI 6224 Connector 1

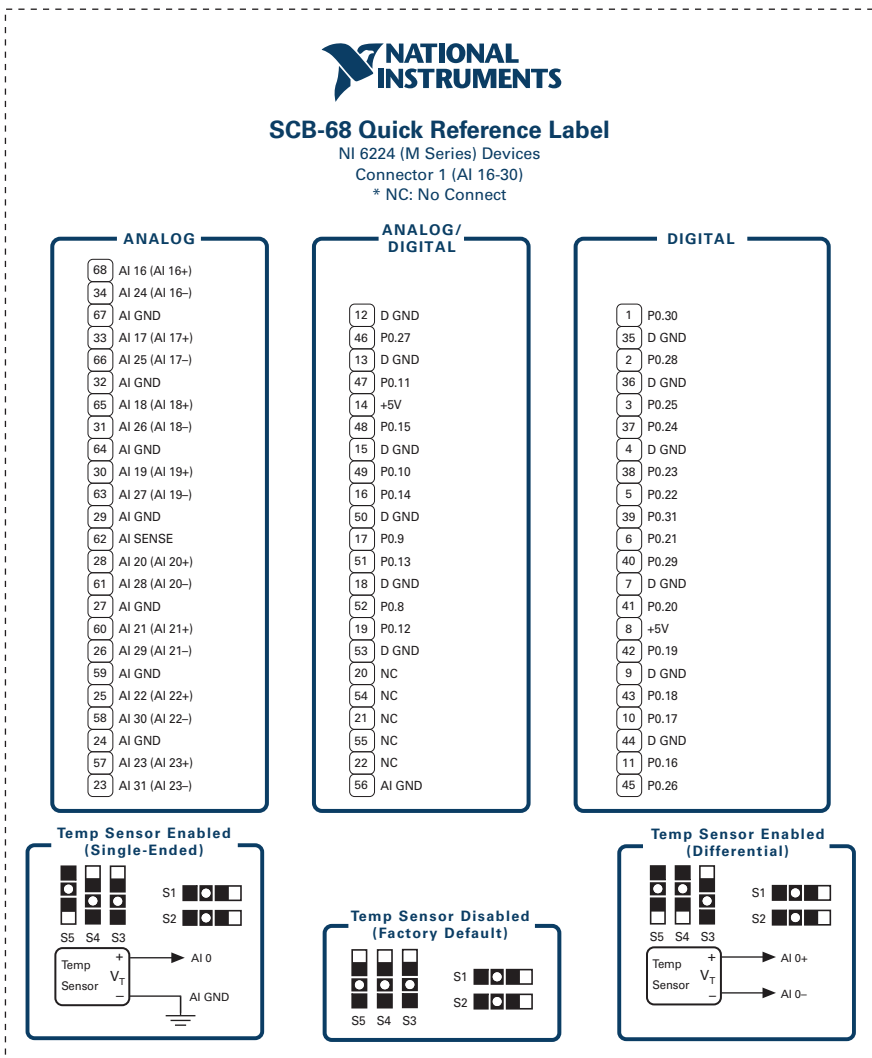

Use the following label if you are connecting the SCB-68 to Connector 1 of NI 6225/6255 and NI 6345/6355/6365/6375 models.

Figure 7. NI 6225/6255 and 6345/6355/6365/6375 Connector 1

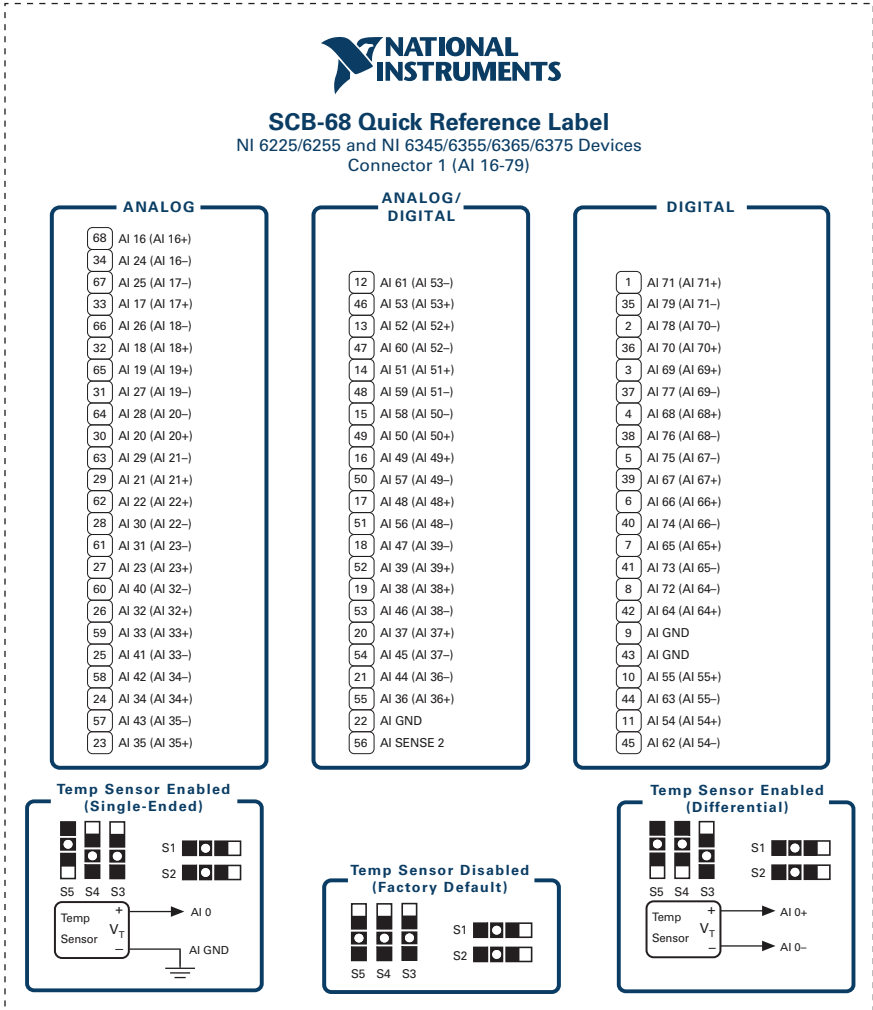

Use the following label if you are connecting the SCB-68 to Connector 1 of NI 6229 and NI 6323/6343 models.

Figure 8. NI 6229 and NI 6323/6343 Connector 1

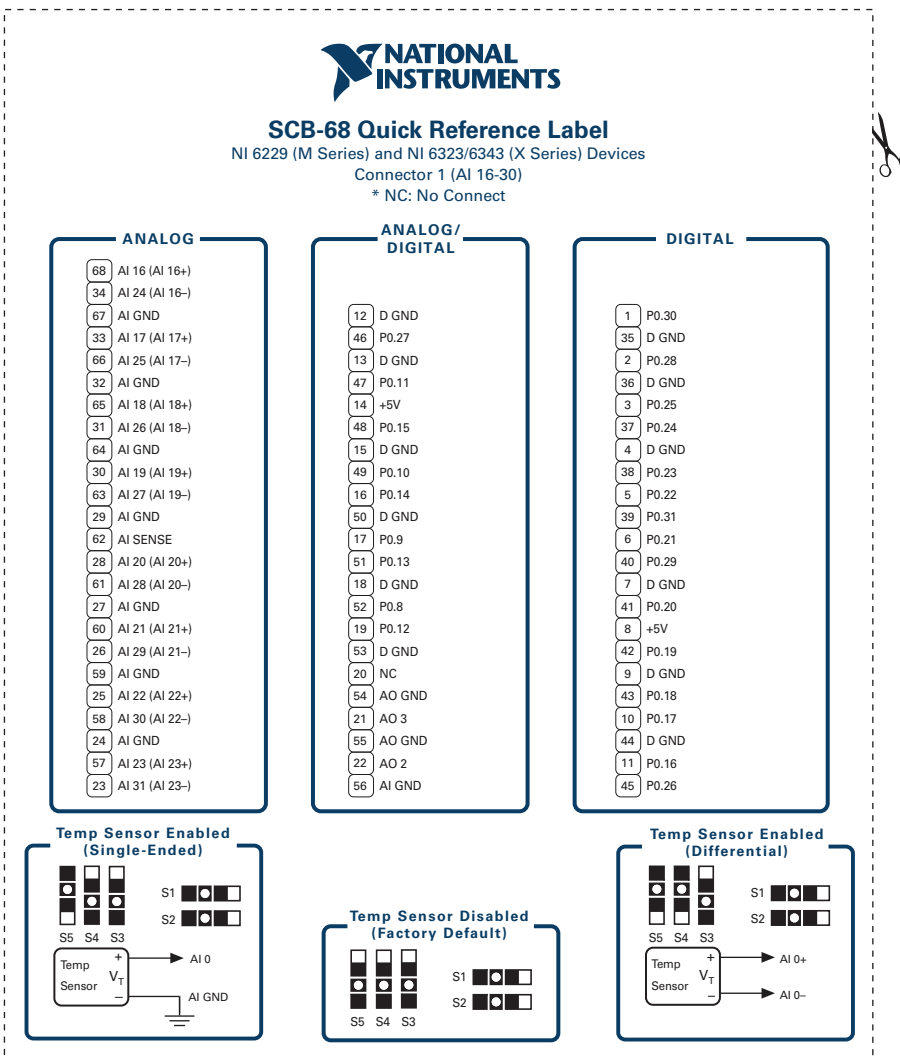

Use the following label if you are connecting the SCB-68 to Connector 1 of NI 6259/6289 and NI 6353/6358/6363/6368/6378 models.

Figure 9. NI 6259/6289 and NI 6353/6358/6363/6368/6378 Connector 1

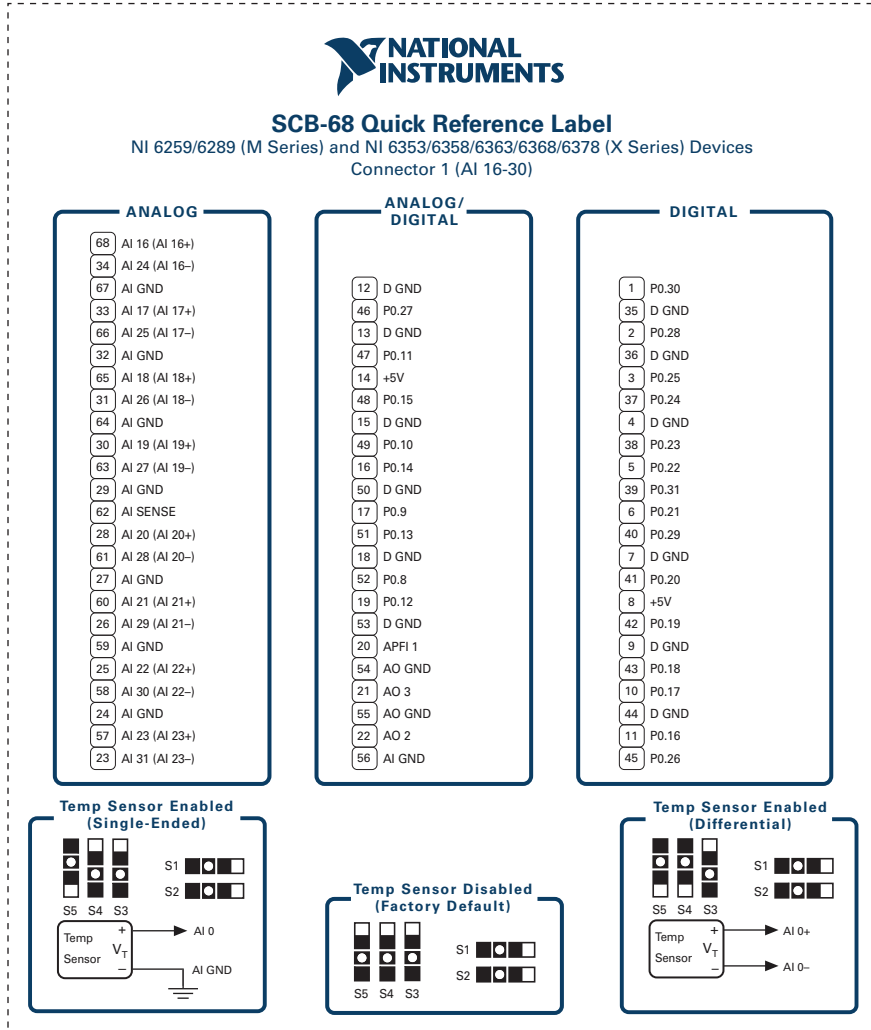

Use the following label if you are connecting the SCB-68 to Connector 2 of NI 6365/6375 models.

Figure 10. NI 6365/6375 Connector 2

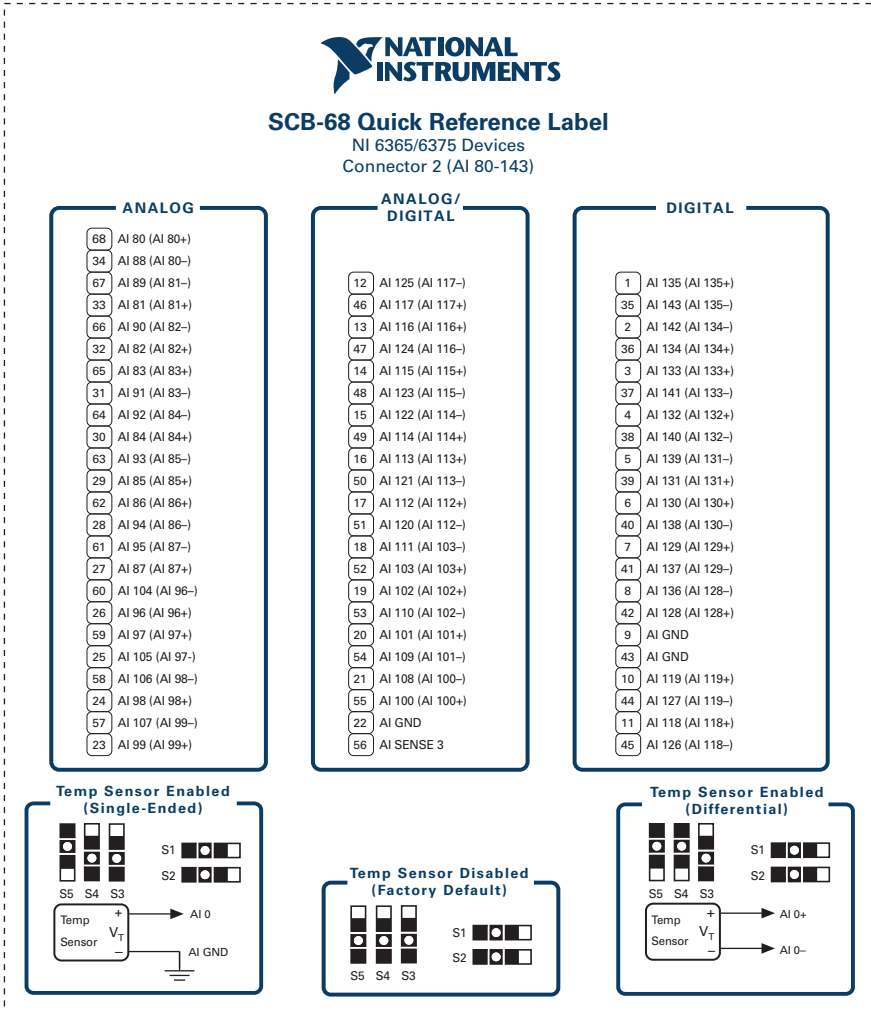

Use the following label if you are connecting the SCB-68 to Connector 3 of the NI 6375 model.

Figure 11. NI 6375 Connector 3

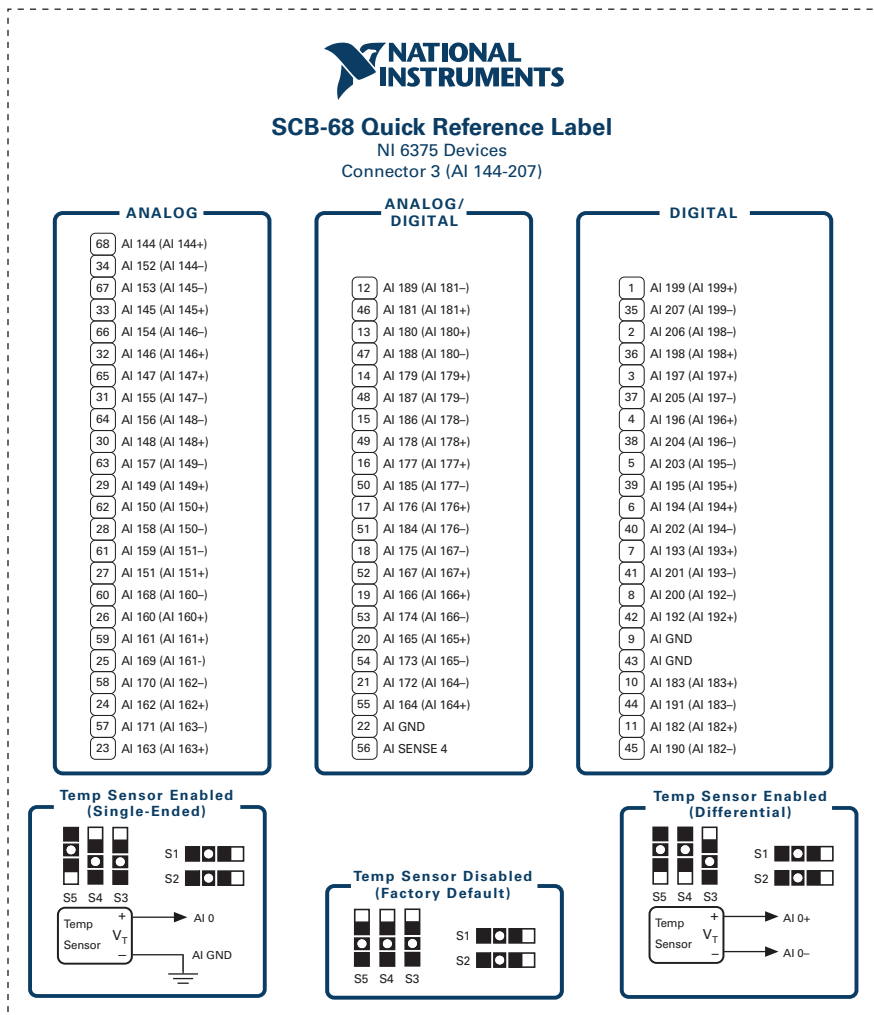

Refer to the *NI Trademarks and Logo Guidelines* at ni.com/trademarks for more information on NI trademarks. Other product and company names mentioned herein are trademarks or trade names of their respective companies. For patents covering NI products/technology, refer to the appropriate location: **Help»Patents** in your software, the `patents.txt` file on your media, or the *National Instruments Patents Notice* at ni.com/patents. You can find information about end-user license agreements (EULAs) and third-party legal notices in the readme file for your NI product. Refer to the *Export Compliance Information* at ni.com/legal/export-compliance for the NI global trade compliance policy and how to obtain relevant HTS codes, ECCNs, and other import/export data. NI MAKES NO EXPRESS OR IMPLIED WARRANTIES AS TO THE ACCURACY OF THE INFORMATION CONTAINED HEREIN AND SHALL NOT BE LIABLE FOR ANY ERRORS. U.S. Government Customers: The data contained in this manual was developed at private expense and is subject to the applicable limited rights and restricted data rights as set forth in FAR 52.227-14, DFAR 252.227-7014, and DFAR 252.227-7015.

© 2018 National Instruments. All rights reserved.