

COMPREHENSIVE SERVICES

We offer competitive repair and calibration services, as well as easily accessible documentation and free downloadable resources.

SELL YOUR SURPLUS

We buy new, used, decommissioned, and surplus parts from every NI series. We work out the best solution to suit your individual needs.

 Sell For Cash  Get Credit  Receive a Trade-In Deal

OBSOLETE NI HARDWARE IN STOCK & READY TO SHIP

We stock **New**, **New Surplus**, **Refurbished**, and **Reconditioned** NI Hardware.



Bridging the gap between the manufacturer and your legacy test system.

 1-800-915-6216

 www.apexwaves.com

 sales@apexwaves.com

All trademarks, brands, and brand names are the property of their respective owners.

Request a Quote

 **CLICK HERE**

PXIe-8830MC

NI PXImc Devices

NI PXIe-8830mc PXImc Processor Module

This document includes instructions for installing and configuring your NI PXIe-8830mc PXImc processor module.

Contents

| | |
|---|----|
| Products Covered..... | 1 |
| Conventions..... | 2 |
| Getting Started..... | 2 |
| Unpacking..... | 2 |
| Electrical..... | 2 |
| Preparing the Environment..... | 3 |
| Hardware Installation..... | 3 |
| Powering On the PXImc System..... | 4 |
| Powering Off the PXImc System..... | 4 |
| Software Installation and Configuration..... | 4 |
| LabVIEW RT Installation..... | 4 |
| NI PXIe-8830mc Front Panel..... | 8 |
| Removing the NI PXIe-8830mc from a PXI Express Chassis..... | 9 |
| Cleaning..... | 9 |
| Common Configuration Questions..... | 10 |
| General Questions..... | 10 |
| Upgrade Information..... | 10 |
| Troubleshooting..... | 11 |
| What if the processor module does not boot?..... | 11 |
| My system boots fine as long as a particular module is not in my chassis..... | 12 |
| My CMOS is corrupted. How do I set it back to default?..... | 12 |
| Worldwide Support and Services..... | 13 |

Products Covered

This document covers the following products:

- NI PXIe-8830mc (156252x-011L)



Note Following the model number above is the specific NI assembly number in parentheses. Ensure that the specifications of interest match the NI assembly number printed on the board. x denotes all letter revisions of the assembly.

Conventions

The following conventions appear in this manual:

| | |
|------------------------------|---|
| CompactPCI Express/ CPCIe | The terms <i>CompactPCI Express</i> and <i>CPCIe</i> are interchangeable in this guide. |
| PCI Express/PCIE | The terms <i>PCI Express</i> and <i>PCIE</i> are interchangeable in this guide. |
| PXI Express/PXIE | The terms <i>PXI Express</i> and <i>PXIE</i> are interchangeable in this guide. |

Getting Started

This section includes instructions for unpacking and installing your NI PXIe-8830mc processor module, including setting up your processor module to run LabVIEW Real-Time. It also describes the processor module's front panel connectors.

Unpacking

The NI PXIe-8830mc ships in an antistatic package to prevent electrostatic discharge from damaging device components. To prevent such damage when handling the device, ground yourself using a grounding strap or by holding a grounded object, such as your computer chassis, and complete the following steps:

1. Touch the antistatic package to a metal part of the chassis before removing the device from the package.



Caution Never touch the exposed pins of connectors.

2. Remove the device from the package and inspect the device for loose components or any other sign of damage.
3. Notify National Instruments if the device appears damaged in any way. Do *not* install a damaged device into your chassis.

Electrical

| Power Rail | Typical Current | Maximum Current |
|---------------------|-----------------|-----------------|
| +3.3 V | 1450 mA | 2180 mA |
| +12 V | 3750 mA | 3940 mA |
| +5 V _{Aux} | 70 mA | 110 mA |

Note: Does not include any attached USB devices.

Preparing the Environment

Ensure the environment you are using the NI PXIe-8830mc in meets the following specifications.

| | |
|--------------------------------|---|
| Ambient temperature range..... | 0 to 40 °C (maximum performance) |
| Ambient temperature range..... | 0 to 55 °C (Tested in accordance with IEC-60068-2-1 and IEC-60068-2-2. Meets MIL-PRF-28800F Class 3 low temperature limit and MIL-PRF-28800F Class 2 high temperature limit.) |
| Relative humidity range..... | 10 to 90%, noncondensing (Tested in accordance with IEC-60068-2-56.) |
| Maximum altitude..... | 2,000 m (800 mbar) (at 25 °C ambient temperature) |
| Pollution Degree..... | 2 |

Indoor use only.



Note Refer to the *NI PXIe-8830mc User Manual* for full NI PXIe-8830mc specifications.

Hardware Installation

The following are general instructions for installing the NI PXIe-8830mc.

Complete the following steps to install the NI PXIe-8830mc in your PXI Express chassis.

1. Power off your PXI Express chassis, but leave it plugged in while installing the NI PXIe-8830mc. The power cord grounds the chassis and protects it from electrical damage while you install the module.



Caution To protect both yourself and the chassis from electrical hazards, leave the chassis off until you finish installing the NI PXIe-8830mc.

2. Remove or open any doors or covers blocking access to the slot in which you intend to install the NI PXIe-8830mc.
3. Touch a metal part of the chassis to discharge any static electricity that might be on your clothes or body.
4. Make sure the injector/ejector handle is in its downward position. Be sure to remove all connector packaging and protective caps from retaining screws on the module.
5. Identify the slot in which the NI PXIe-8830mc will be installed in the chassis. Refer to the following table to determine which slot types the NI PXIe-8830mc is compatible with.

Table 1. NI PXIe-8830mc Slot Type Compatibility

| NI PXI Express Product | PXI Express Chassis | | |
|------------------------|---------------------|--------------|-----------------------|
| | Controller ▲ | Peripheral ● | Hybrid ● ⁿ |
| NI PXIe-8830mc | — | X | X |

- Align the NI PXIe-8830mc with the card guides on the top and bottom of the slot. Hold the handle as you slowly slide the module into the chassis until the handle catches on the injector/ejector rail.



Caution Do not raise the injector/ejector handle as you insert the NI PXIe-8830mc. It will not insert properly unless the handle is in its downward position so that it does not interfere with the injector/ejector rail on the chassis.

- Raise the injector/ejector handle until the module firmly seats into the backplane receptacle connectors. The front panel of the NI PXIe-8830mc should be even with the front panel of the chassis.
- Tighten the bracket-retaining screws on the top and bottom of the front panel to secure the NI PXIe-8830mc to the chassis.
- Replace or close any doors or covers to the chassis.

Powering On the PXImc System

The NI PXIe-8830mc powers on automatically when the chassis is powered on. To power on the NI PXIe-8830mc, turn on the chassis. The NI PXIe-8830mc boots up to OS when the system controller boots up when the chassis is powered on.

Powering Off the PXImc System

The NI PXIe-8830mc powers off automatically when the chassis is powered off. You also can power off the NI PXIe-8830mc by shutting down the system controller.

Software Installation and Configuration

The NI PXIe-8830mc requires the NI-PXImc driver software to enable its features. Refer to the `readme.html` file on the NI-PXImc driver DVD for software installation instructions.

LabVIEW RT Installation

This section explains software installation and switch configuration for LabVIEW RT on your PXImc processor module.

LabVIEW RT Software Installation

The following section describes the necessary steps to set up your PXImc processor module to run LabVIEW Real-Time. In this section you will configure the processor module boot mode, verify or change IP settings, and install LabVIEW Real-Time software.

Complete the following steps to install the LabVIEW RT software.

- Boot the NI PXImc processor module into the real-time operating system.
The PXImc processor module automatically boots into LabVIEW RT Safe Mode when no software is installed. LabVIEW RT Safe Mode loads with the basic real-time operating

system and automatically attempts to connect to the network using DHCP. If DHCP is not available, it then connects to the network with a link-local IP address.

2. Open Measurement & Automation Explorer (MAX) on another computer in the same subnet and expand the **Remote Systems** branch. MAX lists the PXImc processor module as the model name of the processor module followed by the MAC address (for example, *NI-PXIe-8830mc 00802f108562*).



Note The other computer must have LabVIEW, LabVIEW RT, and any desired drivers installed.



Tip Record the PXImc processor module MAC address, located on the side of the processor module, for use in identifying the processor module. You also can remove the label and place it on the front of the processor module for easier access.

3. Click the appropriate PXImc processor module entry to access the **Network Settings** tab in the right pane view.
4. (Optional) Enter a name for the RT target in the **Name** text box.
5. (Optional) Set the network configuration options of the RT target in the **IP Settings** section and click the **Apply** button.

For information about configuring network settings, refer to *Configuring Network Settings* in *Measurement & Automation Explorer Help*, accessible by browsing to **MAX Remote Systems Help»LabVIEW Real-Time Target Configuration»Configuring Network Settings** from the help **Contents** tab.



Note When any IP or identification settings are changed, you are prompted to reboot the processor module for the changes to take effect. Click **Yes** to reboot the RT target automatically. You also can reboot the processor module by right-clicking on the target name under **Remote Systems** and selecting **Reboot**.

After rebooting the PXImc processor module, it appears in the **Remote Systems** category with the assigned name.

6. Expand the PXImc processor module view in the **Remote Systems** branch and select **Software**.
7. Click the **Add/Remove Software** button in the toolbar to launch the LabVIEW Real-Time Software Wizard.
8. Install the LabVIEW Real-Time software and device drivers that you require on the RT target. (At a minimum, you must install LabVIEW RT and PXImc drivers.) Refer to the NI website at ni.com/info and enter the Info Code `etspc` for the latest information about supported software.

After software installation, the processor module automatically reboots, and you now can program it using LabVIEW Real-Time.



Note Refer to *Getting Started with the LabVIEW Real-Time Module* on your host computer for more information about setting up your RT target.

LabVIEW RT Configuration Switches

Use the LabVIEW RT configuration switches to configure LabVIEW RT if it is installed on the processor module. If you are not using LabVIEW RT, these switches should remain in the OFF position. The processor module reads these switches only after a system reset.

The NI PXIe-8830mc processor module includes the following LabVIEW RT configuration switches:

- Switch 1—**Boot LabVIEW RT**: Set this switch to ON to boot LabVIEW RT.
- Switch 2—**Boot Safe Mode**: Set this switch to ON to boot LabVIEW RT into safe mode to reconfigure TCP/IP settings and to download or update software from a host computer. This switch overrides the behavior of Switch 1. Booting the processor module into safe mode does not start the embedded LabVIEW RT engine. After changing the settings or software, reboot the processor module with this switch OFF to resume normal operation.
- Switch 3—**Disable Startup VI**: Set this switch to ON to prevent VIs from automatically running at startup if the processor module becomes inaccessible because of a startup VI.
- Switch 4—**Reset IP Address**: Set this switch to ON to reset the IP address and other TCP/IP settings to their factory defaults. Use this switch if moving the processor module to a different subnet or if the current TCP/IP settings are invalid.



Note By default, the target automatically attempts to connect to the network using DHCP. If the target cannot initiate a DHCP connection, the target connects to the network with a link-local IP address or `169.254.x.x`.

The following figure shows the location of the LabVIEW RT configuration switches. The switches are shown in the OFF position.

Figure 1. LabVIEW RT Configuration Switches

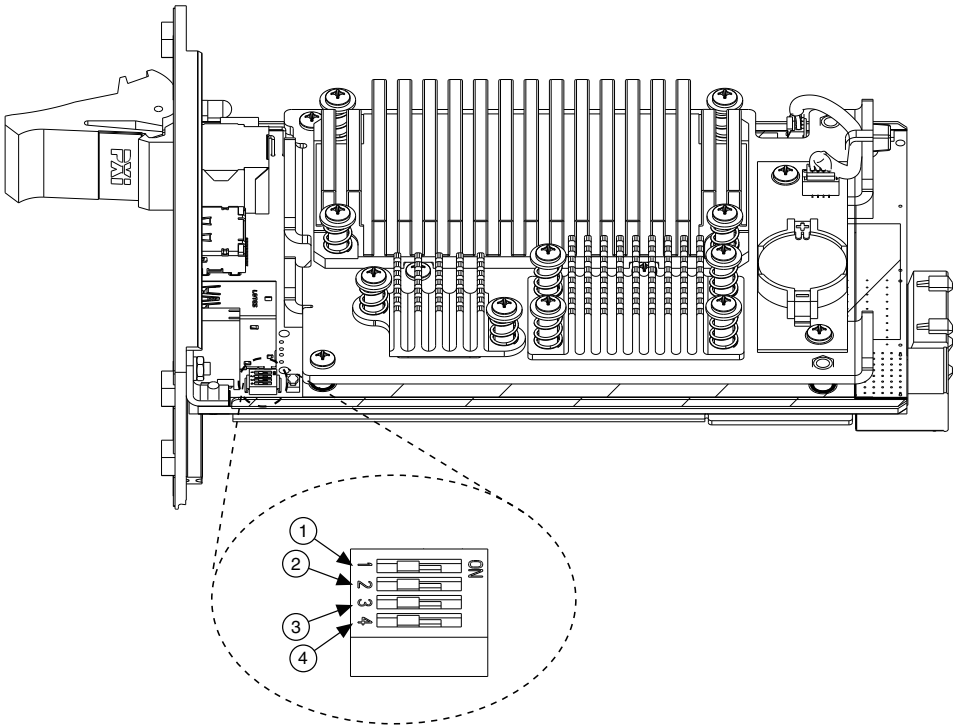

- 1. Switch 1—Boot LabVIEW RT
- 2. Switch 2—Boot Safe Mode

- 3. Switch 3—Disable Startup VI
- 4. Switch 4—Reset IP Address

NI PXIe-8830mc Front Panel

The following figure shows the front panel layout of the NI PXIe-8830mc.

Figure 2. NI PXIe-8830mc Front Panel

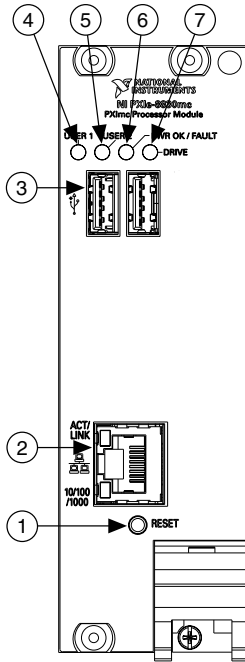

- | | |
|-----------------------|---------------------|
| 1. Reset Button | 5. User 2 LED |
| 2. Ethernet Connector | 6. PWR OK/FAULT LED |
| 3. USB Connectors | 7. Drive LED |
| 4. User 1 LED | |

Front Panel Connectors

The following table lists various peripherals and their corresponding NI PXIe-8830mc external connectors, bus interfaces, and functions.

| Peripheral | External Connector | Description |
|---------------|---|------------------------------------|
| Ethernet Port | LAN (RJ45) | 10/100/1000 Ethernet Intel i217 |
| USB 2.0 | USB 4-pin Series A stacked receptacle (2 ports) | USB 2.0 capable |

Front Panel Features

The NI PXIe-8830mc has the following front-panel features:

- A system reset pushbutton (press the button to reset the processor module).
- Four front panel LEDs that show PC status:
 - *PWR OK/FAULT LED*—Indicates the processor module status. The LED indicates one of the following states:
 - Green ON steady—PXI Express and onboard power is on and within regulation limits.
 - Green BLINKING—The processor module has entered the soft off state and is safe to power down.



Note Applicable only when chassis is set to **Manual**.

- OFF—The processor module is powered off.
- Red BLINKING—The processor module detected a power rail fault when trying to boot.
- Red Solid—The processor module detected a thermal fault and has shut down to protect the system.
- *USER* —Two bi-color green/yellow LEDs (**USER 1** and **USER 2**) that you can define to meet the needs of your LabVIEW application.
- *DRIVE* —Indicates when an access to the internal hard disk is occurring.

Removing the NI PXIe-8830mc from a PXI Express Chassis

To remove the NI PXIe-8830mc from a PXI Express chassis, complete the following steps.

1. Power off the chassis.
2. Remove any cables that may be attached to the processor module front panel.
3. Unscrew the 4 bracket-retaining screws in the front panel.
4. Press the injector/ejector handle down.
5. Slide the unit out of the chassis.

Cleaning

Use a dry, low-velocity stream of air to clean the NI PXIe-8830mc processor module. If needed, use a soft, nonmetallic brush for cleaning around components.

Make sure that the device is completely dry and free from contaminants before returning it to service.

Common Configuration Questions

This section answers common configuration questions you may have when using an NI PXIe-8830mc processor module.

General Questions

What do the LEDs on the front panel mean?

Refer to the LED status descriptions in the *Front Panel Features* section.

After shutting down my NI PXIe-8830mc, the Ethernet LEDs continue to blink. Is it safe to remove my processor module or disconnect power?

The NI PXIe-8830mc Intel WGI217LM Ethernet device remains powered even after shutdown. It is safe to remove your processor module or disconnect power.

Upgrade Information

How do I upgrade system memory?

You can change the amount of installed RAM on the NI PXIe-8830mc by upgrading the DDR4 SO-DIMMs. Complete the following steps to upgrade the RAM.

1. Remove the NI PXIe-8830mc from the PXI Express chassis.
2. Locate the DDR4 SO-DIMM module on the side of the processor module, as shown in the figure.
3. Remove the installed DDR4 SO-DIMM module, if necessary.
4. Install the new DDR4 SO-DIMM module into the slot.

NI PXIe-8830mc System Memory Information

National Instruments offers the following types of SO-DIMMs for use with the NI PXIe-8830mc processor module.



Note National Instruments has tested and verified that the DDR3 SO-DIMMs we sell work with the NI PXIe-8830mc processor module. We recommend you purchase your DDR3 SO-DIMM modules from National Instruments. Other off-the-shelf DDR3 SO-DIMM modules are not guaranteed to work properly.

- PC3-12800 (DDR3 1600) 4 GB, 256 MB × 64, CL 9, 1.18 in. max (NI part number 782341-4096)
- PC3-12800 (DDR3 1600) 8 GB, 512 MB × 64, CL 9, 1.18 in. max (NI part number 782341-8192)

Figure 3. Installing a DDR3 SO-DIMM in an NI PXIe-8830mc Processor Module

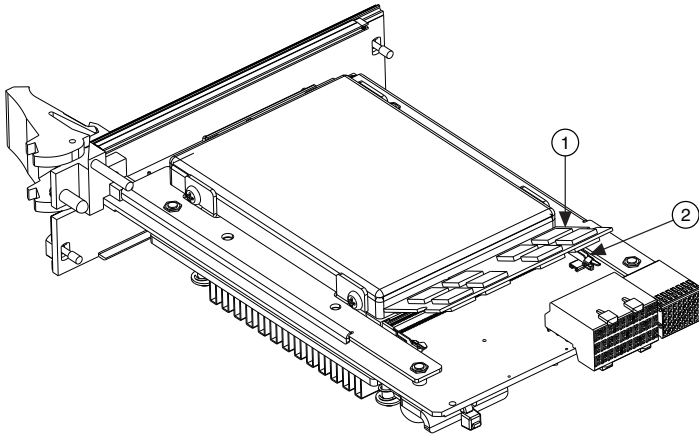

1. DDR3 SO-DIMM Module
2. DDR3 SO-DIMM Socket

How do I flash a new BIOS?

Contact National Instruments for more information.

Where do I get the latest software drivers?

The latest National Instruments software is available from ni.com/downloads.

Troubleshooting

This section answers common troubleshooting questions you may have when using the NI PXIe-8830mc processor module.

What if the processor module does not boot?

Several problems can cause a processor module not to boot. Here are some things to look for and possible solutions.

Things to Notice:

- Ensure that a system controller is installed in slot 1 and working properly.
- Which LEDs come on? The *PWROK/FAULT* LED should stay lit green. The *Drive* LED should blink during boot as the disk is accessed.
- What has changed about the system? Did you recently move the system? Was there electrical storm activity? Did you recently add a new module, memory chip, or piece of software?
- Refer to your chassis documentation for additional troubleshooting steps.

Things to Try:

- Make sure the chassis is plugged in to a working power source.
- Check any fuses or circuit breakers in the chassis or other power supply (possibly a UPS).
- Make sure the processor module is firmly seated in the chassis.
- Remove all other modules (except the system controller) from the chassis.
- Remove any nonessential cables or devices.
- Try the processor module in a different chassis.
- Try a similar processor module in the same chassis.
- Clear the CMOS.
- Recover the hard drive on the processor module.
- Make sure the RAM is properly seated.

My system boots fine as long as a particular module is not in my chassis.

The most common cause of this is a damaged module. Try the module in a different chassis or with a different controller. Also, remove any external cables or terminal blocks connected to the system. If the module does not work in these cases, it is likely damaged. Contact the module manufacturer for further troubleshooting.

Refer to the KnowledgeBase at ni.com/kb or product manuals section at ni.com/manuals for more information specific to the chassis and controller with which you are having difficulties.

My CMOS is corrupted. How do I set it back to default?

Complete the following steps to reset the CMOS.

1. Power off the chassis.
2. Remove the processor module from the chassis.
3. Press the Clear CMOS button (SW1) as shown in the following figure.
4. Wait 10 seconds.
5. Reinstall the processor module in the chassis.

Figure 4. Clearing the CMOS Contents

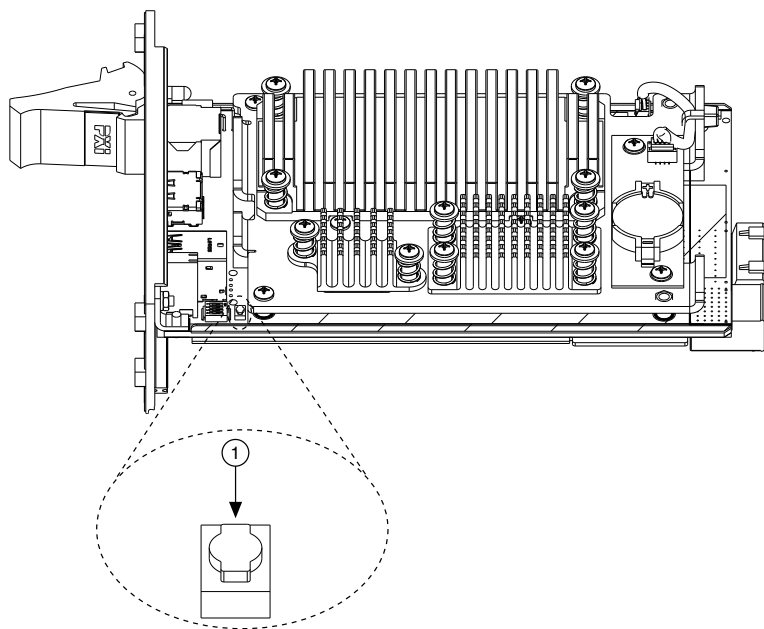

1. Push-Button Switch SW1

Worldwide Support and Services

The National Instruments website is your complete resource for technical support. At ni.com/support, you have access to everything from troubleshooting and application development self-help resources to email and phone assistance from NI Application Engineers.

Visit ni.com/services for NI Factory Installation Services, repairs, extended warranty, and other services.

Visit ni.com/register to register your National Instruments product. Product registration facilitates technical support and ensures that you receive important information updates from NI.

A Declaration of Conformity (DoC) is our claim of compliance with the Council of the European Communities using the manufacturer's declaration of conformity. This system affords the user protection for electromagnetic compatibility (EMC) and product safety. You can obtain the DoC for your product by visiting ni.com/certification. If your product supports calibration, you can obtain the calibration certificate for your product at ni.com/calibration.

National Instruments corporate headquarters is located at 11500 North Mopac Expressway, Austin, Texas, 78759-3504. National Instruments also has offices located around the world.

For telephone support in the United States, create your service request at ni.com/support or dial 1 866 ASK MYNI (275 6964). For telephone support outside the United States, visit the *Worldwide Offices* section of ni.com/niglobal to access the branch office websites, which provide up-to-date contact information, support phone numbers, email addresses, and current events.

Refer to the *NI Trademarks and Logo Guidelines* at ni.com/trademarks for information on National Instruments trademarks. Other product and company names mentioned herein are trademarks or trade names of their respective companies. For patents covering National Instruments products/technology, refer to the appropriate location: **Help»Patents** in your software, the `patents.txt` file on your media, or the *National Instruments Patent Notice* at ni.com/patents. You can find information about end-user license agreements (EULAs) and third-party legal notices in the readme file for your NI product. Refer to the *Export Compliance Information* at ni.com/legal/export-compliance for the National Instruments global trade compliance policy and how to obtain relevant HTS codes, ECCNs, and other import/export data. NI MAKES NO EXPRESS OR IMPLIED WARRANTIES AS TO THE ACCURACY OF THE INFORMATION CONTAINED HEREIN AND SHALL NOT BE LIABLE FOR ANY ERRORS. U.S. Government Customers: The data contained in this manual was developed at private expense and is subject to the applicable limited rights and restricted data rights as set forth in FAR 52.227-14, DFAR 252.227-7014, and DFAR 252.227-7015.

© National Instruments. All rights reserved.

374586A-01 Aug14