

## COMPREHENSIVE SERVICES

We offer competitive repair and calibration services, as well as easily accessible documentation and free downloadable resources.

## SELL YOUR SURPLUS

We buy new, used, decommissioned, and surplus parts from every NI series. We work out the best solution to suit your individual needs.

 Sell For Cash    Get Credit    Receive a Trade-In Deal

## OBSOLETE NI HARDWARE IN STOCK & READY TO SHIP

We stock **New**, **New Surplus**, **Refurbished**, and **Reconditioned** NI Hardware.



*Bridging the gap between the manufacturer and your legacy test system.*

 1-800-915-6216

 [www.apexwaves.com](http://www.apexwaves.com)

 [sales@apexwaves.com](mailto:sales@apexwaves.com)

*All trademarks, brands, and brand names are the property of their respective owners.*

**Request a Quote**

 **CLICK HERE**

**PXIe-8830MC**

# NI PXImc Devices

## NI PXIe-8830mc PXImc Processor Module

This document provides reference information for PXI Express and the NI PXIe-8830mc PXImc processor module.

## Contents

---

Electromagnetic Compatibility Guidelines.....	1
Related Documentation.....	2
PXI Express Features.....	2
Benefits of PXI Express.....	2
NI PXIe-8830mc Overview.....	3
Functional Overview.....	3
Functional Description.....	4
National Instruments Software.....	5
Configuration.....	7
System CMOS.....	7
Upgrading System Memory.....	8
Specifications.....	9
Physical.....	10
Power Requirements.....	11
Environment.....	11
Cleaning.....	12
Safety.....	12
Appendix A: Front Panel Connector Pinouts.....	13
Ethernet.....	13
Universal Serial Bus.....	15
Worldwide Support and Services.....	16

## Electromagnetic Compatibility Guidelines

---

This product was tested and complies with the regulatory requirements and limits for electromagnetic compatibility (EMC) stated in the product specifications. These requirements and limits provide reasonable protection against harmful interference when the product is operated in the intended operational electromagnetic environment.

This product is intended for use in industrial locations. However, harmful interference may occur in some installations, when the product is connected to a peripheral device or test object, or if the product is used in residential or commercial areas. To minimize interference with

radio and television reception and prevent unacceptable performance degradation, install and use this product in strict accordance with the instructions in the product documentation.

Furthermore, any modifications to the product not expressly approved by National Instruments could void your authority to operate it under your local regulatory rules.



**Caution** To ensure the specified EMC performance, operate this product only with shielded cables and accessories.



**Caution** To ensure the specified EMC performance, USB cables must be no longer than 30 m (100 ft). Ethernet cable can be longer than 30 m (100 ft).

## Related Documentation

---

The following documents contain information that you might find helpful as you read this manual:

- Your chassis documentation
- *NI-PXImc™ Help* file included with NI-PXImc driver
- *PXI Express Hardware Specification*, Revision 2.0
- *PXI-6 PXI Express Software Specification*
- *PICMG CompactPCI Express EXP.0 R1.0 Specification*
- *PCI Express Base Specification*, Revision 2.1, PCI Special Interest Group
- *PXI MultiComputing Hardware Specification*, Revision 1.0
- *PXI MultiComputing Software Specification*, Revision 1.0

## PXI Express Features

---

### Benefits of PXI Express

The PXI (PCI eXtensions for Instrumentation) industry standard, an open specification governed by the PXI Systems Alliance (PXISA), has quickly gained adoption and grown in prevalence in test, measurement, and control systems since its release in 1998. One of the key elements driving the rapid adoption of PXI is its use of PCI in the communication backplane. As the commercial PC industry has improved the available bus bandwidth by evolving PCI to PCI Express, PXI is now able to meet even more application needs by integrating PCI Express into the PXI standard. By taking advantage of PCI Express technology in the backplane, PXI Express increases the available PXI bandwidth from up to 132 MB/s to up to 8 GB/s for a more than 60x improvement in bandwidth.

PXI Express maximizes both hardware and software compatibility with PXI modules. PXI Express hybrid slots deliver both PCI and PCI Express signaling to accept devices that use PXI communication and triggering or the newer PXI Express standard. Software compatibility is maintained because PCI Express uses the same OS and driver model as PCI, resulting in complete software compatibility among PCI-based systems, for example PXI, and PCI Express-based systems such as PXI Express.

PXI Express, like PXI, leverages from the CompactPCI specification to define a rugged, modular form factor that offers superior mechanical integrity and easy installation and removal of hardware components. PXI Express products offer higher and more carefully defined levels of environmental performance required by the shock, vibration, temperature, and humidity extremes of industrial environments. Mandatory environmental testing and active cooling is added to the CompactPCI mechanical specification to ease system integration and ensure multivendor interoperability.

The demanding timing and synchronization requirements of instrumentation systems are met by the integrated features of PXI Express. Not only are the trigger bus, 10 MHz system reference clock, and star trigger bus available in PXI retained by PXI Express, but new timing and synchronization features that include a 100 MHz differential system reference clock for the synchronization of multiple modules and three differential star trigger buses for the distribution of precise clock and trigger signals have been added. Differential timing and synchronization signals provide PXI Express systems with increased noise immunity and the ability to transmit clock signals at higher frequencies.

## NI PXIe-8830mc Overview

---

### Functional Overview

The NI PXIe-8830mc is a PXImc device<sup>1</sup> module that allows the attachment of subsystems such as standalone instruments, PCs, or other PXI Express systems to an existing PXI Express system via a high-bandwidth, low-latency PXI Express backplane Gen2 x8 link. The NI PXIe-8830mc contains a PXImc logic block that makes it possible to join systems together nontransparently.

The following figure illustrates where the PXImc logic block is applied to join the root complexes of two systems.

---

<sup>1</sup> Refer to the *PXI-7 PXI MultiComputing Hardware Specification* Revision 1.0, available on the [pxisa.org](http://pxisa.org) website, for relevant terminology and concepts used in this guide.

**Figure 1. PXImc System Diagram**

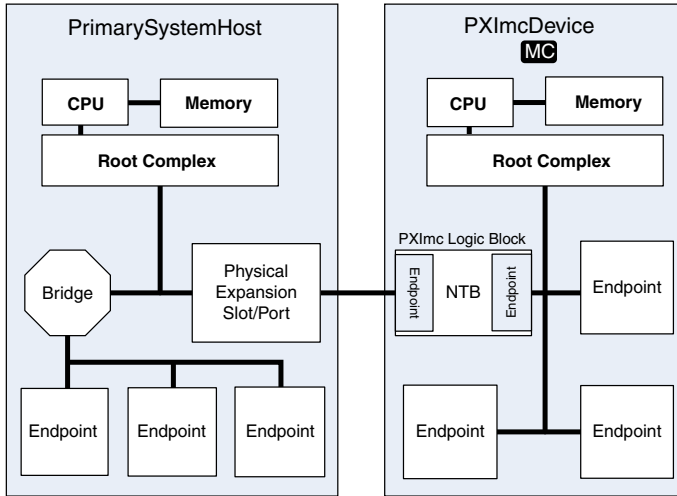

In this example, the system on the right is designated as a PXImc device because it contains the PXImc logic block (that is, the NI PXIe-8830mc). The system on the left is designated the primary system host, which serves as the central connection hub for all other PXImc devices.

Refer to the *NI-PXImc Help* and `readme.html` files included with the NI-PXImc driver for feature updates.

## Functional Description

The NI PXIe-8830mc is a modular PC in a PXI Express 3U-size form factor. The following figure is a functional block diagram of the NI PXIe-8830mc. Following the diagram is a description of each logic block shown.

**Figure 2. NI PXIe-8830mc Block Diagram**

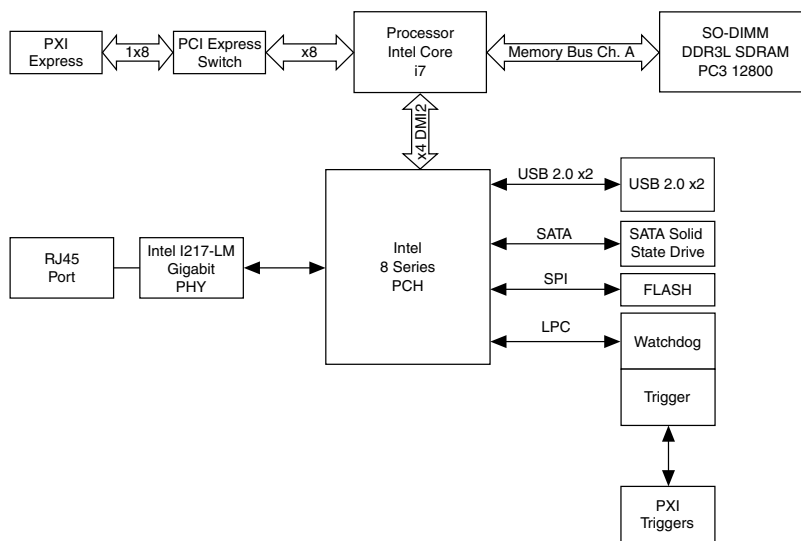

The NI PXIe-8830mc consists of the following logic blocks on one circuit card assembly (CCA):

- The *processor* is an Intel® Core™ i7 4700EQ processor (6 MB Cache, 2.3 GHz). The processor connects to the SO-DIMM block through the DDR3L interface supporting up to 1600 MHz SO-DIMMs, the PCH through a x4 DMI2 (Direct Media Interface) interface supporting up to 5 GT/s per lane.
- The *SO-DIMM block* consists of one 64-bit DDR3L SDRAM socket that can hold up to 8 GB of memory.
- The *Platform Controller Hub (PCH)* provides the USB, PCI Express x1, and LPC interfaces that connect to the peripherals on the NI PXIe-8830mc.
- The *USB block* consists of two Hi-Speed USB 2.0 connectors.
- The *Ethernet Port* block consists of an Intel® I217-LM Gigabit Ethernet Connection.
- The *Watchdog* block consists of a watchdog timer that can reset the processor module or generate triggers.
- The *PXI Express Connectors* connect the NI PXIe-8830mc to the PXI Express/CompactPCI Express backplane.

## National Instruments Software

National Instruments has developed several software tools you can use with the NI PXIe-8830mc.

National Instruments' hardware and software work together to help you make the most of your PXI Express system. The LabVIEW, Measurement Studio, and LabWindows™/CVI™

application development environments combine with leading hardware drivers such as NI-DAQmx to provide exceptional control of NI hardware. Instrument drivers are available at [ni.com/idnet](http://ni.com/idnet) to simplify communication with instruments over a variety of buses.

LabVIEW is a powerful and easy-to-use graphical programming environment you can use to acquire data from thousands of different instruments including USB, IEEE 488.2, VXI, serial, PLCs, and plug-in boards. LabVIEW helps you convert acquired data into meaningful results using powerful data analysis routines. Add-on tools provide additional specialized functionality. For more information, visit [ni.com/labview](http://ni.com/labview) and [ni.com/toolkits](http://ni.com/toolkits).

If you prefer to use Microsoft's Visual Basic, Visual C++, and Visual Studio .NET for the core of your application, Measurement Studio adds tools for measurement and automation to each language. For more information, visit [ni.com/mstudio](http://ni.com/mstudio).

LabWindows/CVI is an interactive ANSI C programming environment designed for building virtual instrument applications. LabWindows/CVI delivers a drag-and-drop editor for building user interfaces, a complete ANSI C environment for building your test program logic, and a collection of automated code generation tools, as well as utilities for building automated test systems, monitoring applications, or laboratory experiments. For more information, visit [ni.com/lwcvl](http://ni.com/lwcvl).

NI-DAQmx provides an extensive library of functions you can call from your application development environment or interactive environment such as NI Signal Express. These functions provide an intuitive API for National Instruments multifunction DAQ products. Features available include analog input (A/D conversion), buffered data acquisition (high-speed A/D conversion), analog output (D/A conversion), waveform generation, digital I/O, counter/timer operations, SCXI signal conditioning, RTSI or PXI Express synchronization, self-calibration, messaging, and acquiring data to extended memory. For more information, visit [ni.com/daq](http://ni.com/daq).

National Instruments modular instruments use specialized drivers suited to each product's specialization. Express VIs provide customized, interactive programming of instruments in a single interface and soft front panels provide an interface for testing the functionality of each instrument with no programming required. NI Switches, DMMs, High-Speed DIO, High-Speed Digitizers, and Sources each have customized drivers for high-end modular instrumentation systems. RF applications leverage two drivers, NI-RFSG and NI-RFSA and Dynamic Signal Acquisition is available through NI-DAQmx. For more information, visit [ni.com/modularinstruments](http://ni.com/modularinstruments).

You can expand the timing and triggering functionality of your PXI Express system with PXI Express Timing and Synchronization products. These products provide precision clock sources, custom routing of triggers for multichassis synchronization, clock sharing, and more and are programmed with NI-Sync. For more information, visit [ni.com/pxi](http://ni.com/pxi).

NI-VISA is the National Instruments implementation of the VISA specification. VISA is a uniform API for communicating and controlling USB, Serial, GPIB, PXI, PXI Express, VXI,

and various other types of instruments. This API aids in the creation of portable applications and instrument drivers. For information about writing your own PXI Express instrument driver with NI-VISA, refer to the *NI-VISA Getting Started Manual* and the `readme.txt` file in the NI-VISA directory. For more information, visit [ni.com/visa](http://ni.com/visa).

With LabVIEW for Linux and support for more than two hundred devices on Linux with the NI-DAQmx driver, you now can create Virtual Instruments based on the Linux OS. The NI-VISA driver for Linux has improved instrument control in Linux, and NI Modular Instruments are partially supported. For more information, visit [ni.com/linux](http://ni.com/linux).

## Configuration

---

### System CMOS

The NI PXIe-8830mc contains memory backed up by a battery to store BIOS configuration information.

Complete the following steps to clear the CMOS contents:

1. Power off the chassis.
2. Remove the processor module from the chassis.
3. Press the push-button switch, as shown in the following figure.
4. Wait 10 seconds.
5. Reinstall the processor module in the chassis.



**Figure 3. Clearing the CMOS Contents**

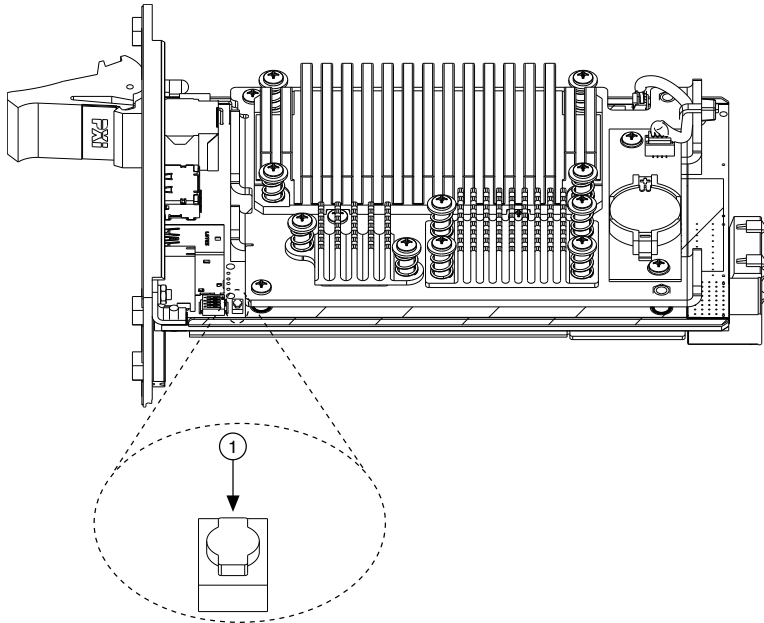

1. Push-Button Switch SW1

## Upgrading System Memory

You can change the amount of installed RAM on the NI PXIe-8830mc by upgrading the DDR3 SO-DIMMs. Complete the following steps to upgrade the RAM.

1. Remove the NI PXIe-8830mc from the PXI Express chassis.
2. Locate the DDR3 SO-DIMM module on the side of the processor module, as shown in the figure.
3. Remove the installed DDR3 SO-DIMM module, if necessary.
4. Install the new DDR3 SO-DIMM module into the slot.

## NI PXIe-8830mc System Memory Information

National Instruments offers the following types of SO-DIMMs for use with the NI PXIe-8830mc processor module.



**Note** National Instruments has tested and verified that the DDR3 SO-DIMMs we sell work with the NI PXIe-8830mc processor module. We recommend you purchase

your DDR3 SO-DIMM modules from National Instruments. Other off-the-shelf DDR3 SO-DIMM modules are not guaranteed to work properly.

- PC3-12800 (DDR3 1600) 4 GB, 256 MB × 64, CL 9, 1.18 in. max (NI part number 782341-4096)
- PC3-12800 (DDR3 1600) 8 GB, 512 MB × 64, CL 9, 1.18 in. max (NI part number 782341-8192)

**Figure 4.** Installing a DDR3 SO-DIMM in an NI PXIe-8830mc Processor Module

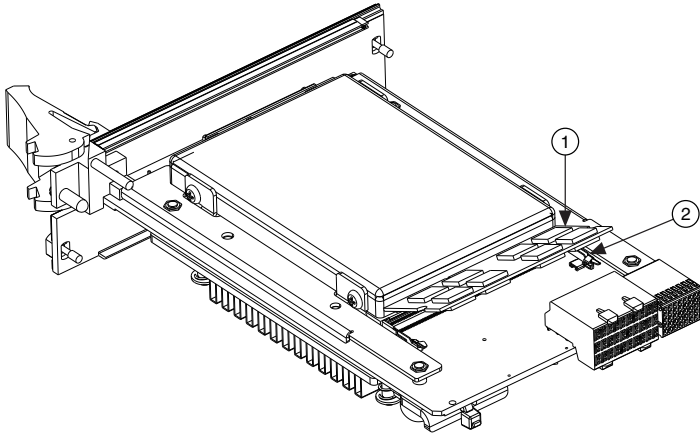

1. DDR3 SO-DIMM Module
2. DDR3 SO-DIMM Socket

## Specifications

This section lists the system specifications for the following product only:

- NI PXIe-8830mc (156252x-011L)



**Note** The NI assembly number in parentheses follows the model number. Ensure that the specifications of interest match the NI assembly number on either the front or back side of the board.



**Note** *x* denotes all assembly letter revisions.



**Note** These specifications are typical at 25 °C, unless otherwise stated, and are subject to change without notice.

# Physical

- Board dimensions.....2-Slot 3U PXI Express
- Slot requirements.....Two peripheral slot (PXI Express)
- Weight.....0.82 kg (1.80 lb) typical

**Figure 5. NI PXIe-8830mc Front Panel Dimensions**

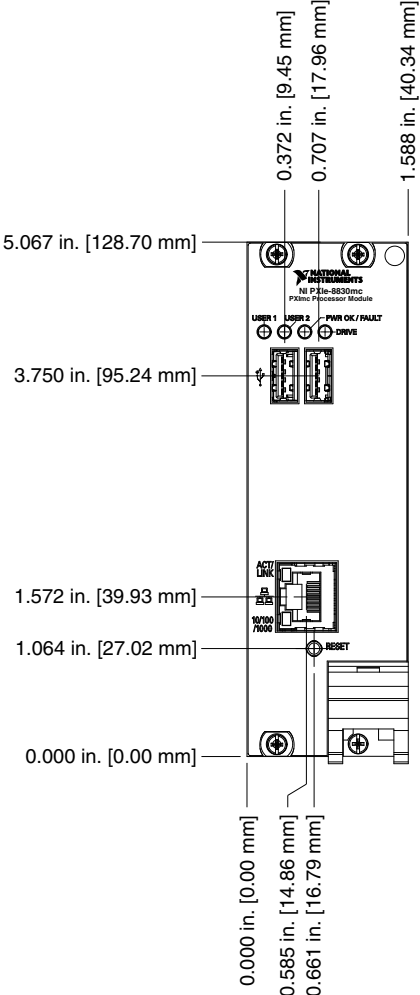

# Power Requirements

Power Rail	Typical Current	Maximum Current
+3.3 V	1450 mA	2180 mA
+12 V	3750 mA	3940 mA
+5 V <sub>Aux</sub>	70 mA	110 mA

**Note:** Does not include any attached USB devices.

## Environment

Maximum altitude.....2,000 m (800 mbar)

Pollution Degree.....2

Indoor use only.

## Operating Environment

Ambient temperature range.....0 to 40 °C  
(maximum performance)

Ambient temperature range.....0 to 55 °C (Tested in accordance with IEC-60068-2-1 and IEC-60068-2-2. Meets MIL-PRF-28800F Class 3 low temperature limit and MIL-PRF-28800F Class 2 high temperature limit.)

Relative humidity range.....10 to 90%, noncondensing (Tested in accordance with IEC-60068-2-56.)

## Storage Environment

Ambient temperature range.....-40 to 71 °C (Tested in accordance with IEC-60068-2-1 and IEC-60068-2-2. Meets MIL-PRF-28800F Class 3 limits.)

Relative humidity range.....5 to 95%, noncondensing (Tested in accordance with IEC-60068-2-56.)

## Shock and Vibration

Operational shock.....30 g peak, half-sine, 11 ms pulse (Tested in accordance with IEC-60068-2-27. Meets MIL-PRF-28800F Class 2 limits.)

## Random Vibration

Operating.....	5 to 500 Hz, 0.3 g <sub>rms</sub>
Nonoperating.....	5 to 500 Hz, 2.4 g <sub>rms</sub> (Tested in accordance with IEC-60068-2-64. Nonoperating test profile exceeds the requirements of MIL-PRF-28800F, Class 3.)

## Cleaning

Use a dry, low-velocity stream of air to clean the NI PXIe-8830mc processor module. If needed, use a soft, nonmetallic brush for cleaning around components.

Make sure that the device is completely dry and free from contaminants before returning it to service.

## Safety

This product is designed to meet the requirements of the following electrical equipment safety standards for measurement, control, and laboratory use:

- IEC 61010-1, EN 61010-1
- UL 61010-1, CSA 61010-1



**Note** For UL and other safety certifications, refer to the product label or the [Online Product Certification](#) section.

## Electromagnetic Compatibility

This product meets the requirements of the following EMC standards for electrical equipment for measurement, control, and laboratory use:

- EN 61326-1 (IEC 61326-1): Class A emissions; Basic immunity
- EN 55011 (CISPR 11): Group 1, Class A emissions
- AS/NZS CISPR 11: Group 1, Class A emissions
- FCC 47 CFR Part 15B: Class A emissions
- ICES-001: Class A emissions



**Note** In the United States (per FCC 47 CFR), Class A equipment is intended for use in commercial, light-industrial, and heavy-industrial locations. In Europe, Canada, Australia and New Zealand (per CISPR 11) Class A equipment is intended for use only in heavy-industrial locations.



**Note** Group 1 equipment (per CISPR 11) is any industrial, scientific, or medical equipment that does not intentionally generates radio frequency energy for the treatment of material or inspection/analysis purposes.



**Note** For EMC declarations and certifications, and additional information, refer to the [Online Product Certification](#) section.

# CE Compliance

This product meets the essential requirements of applicable European Directives, as follows:

- 2006/95/EC; Low-Voltage Directive (safety)
- 2004/108/EC; Electromagnetic Compatibility Directive (EMC)

## Online Product Certification

To obtain product certifications and the DoC for this product, visit [ni.com/certification](https://ni.com/certification), search by model number or product line, and click the appropriate link in the Certification column.

## Environmental Management

NI is committed to designing and manufacturing products in an environmentally responsible manner. NI recognizes that eliminating certain hazardous substances from our products is beneficial to the environment and to NI customers.

For additional environmental information, refer to the *Minimize Our Environmental Impact* web page at [ni.com/environment](https://ni.com/environment). This page contains the environmental regulations and directives with which NI complies, as well as other environmental information not included in this document.

## Waste Electrical and Electronic Equipment (WEEE)



**EU Customers** At the end of the product life cycle, all NI products must be disposed of according to local laws and regulations. For more information about how to recycle NI products in your region, visit [ni.com/environment/weee](https://ni.com/environment/weee).

## 电子信息产品污染控制管理办法（中国 RoHS）



**中国客户** National Instruments 符合中国电子信息产品中限制使用某些有害物质指令 (RoHS)。关于 National Instruments 中国 RoHS 合规性信息，请登录 [ni.com/environment/rohs\\_china](https://ni.com/environment/rohs_china)。(For information about China RoHS compliance, go to [ni.com/environment/rohs\\_china](https://ni.com/environment/rohs_china).)

# Appendix A: Front Panel Connector Pinouts

---

## Ethernet

The following figure shows the location and pinouts for the Ethernet connector on the NI PXIe-8830mc. The following table lists and describes the Ethernet connector signals.

AMP manufactures a mating connector, part number 554739-1.

**Figure 6.** Ethernet Connector Location and Pinout

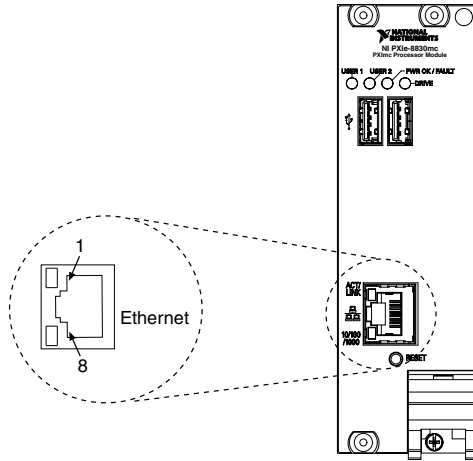

**Table 1.** Ethernet Connector Signals

Pin	Fast Ethernet	Gigabit Ethernet
1	TX+	TX_A+
2	TX-	TX_A-
3	RX+	RX_B+
4	NC	TX_C+
5	NC	TX_C-
6	RX-	RX_B-
7	NC	RX_D+
8	NC	RX_D-



**Note** The Ethernet processor module can perform an automatic crossover, thus eliminating the need for crossover cables.

**Table 2.** 10/100/1000 LAN Connector LED States

LED	Color	LED State	Condition
ACT/LINK	Green	Off	LAN link is not established.
ACT/LINK	Green	On (steady state)	LAN link is established.

**Table 2.** 10/100/1000 LAN Connector LED States (Continued)

LED	Color	LED State	Condition
ACT/LINK	Green	On (brighter and pulsing)	The processor module is communicating with another computer on the LAN.
10/100/1000	(None)	Off	10 Mbit/sec data rate is selected.
10/100/1000	Green	On	100 Mbit/sec data rate is selected.
10/100/1000	Amber	On	1000 Mbit/sec data rate is selected.

## Universal Serial Bus

The following figure shows the location and pinouts for the Universal Serial Bus (USB) connector on the NI PXIe-8830mc. Each processor module has two USB ports on the front panel. The following table lists and describes the USB connector signals.

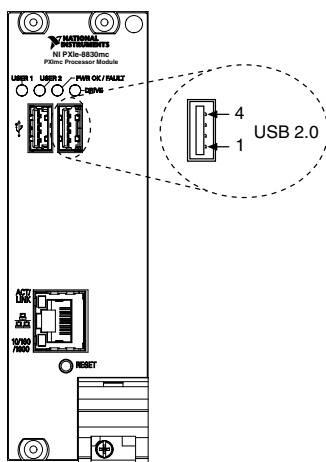
**Figure 7.** USB Connector Location and Pinout**Table 3.** USB 2.0 Connector Signals

Pin	Signal Name	Signal Description
1	VCC	Cable Power (+5 V)
2	-Data	USB Data -



**Table 3. USB 2.0 Connector Signals (Continued)**

Pin	Signal Name	Signal Description
3	+Data	USB Data +
4	GND	Ground

## Worldwide Support and Services

The National Instruments website is your complete resource for technical support. At [ni.com/support](https://ni.com/support), you have access to everything from troubleshooting and application development self-help resources to email and phone assistance from NI Application Engineers.

Visit [ni.com/services](https://ni.com/services) for NI Factory Installation Services, repairs, extended warranty, and other services.

Visit [ni.com/register](https://ni.com/register) to register your National Instruments product. Product registration facilitates technical support and ensures that you receive important information updates from NI.

A Declaration of Conformity (DoC) is our claim of compliance with the Council of the European Communities using the manufacturer's declaration of conformity. This system affords the user protection for electromagnetic compatibility (EMC) and product safety. You can obtain the DoC for your product by visiting [ni.com/certification](https://ni.com/certification). If your product supports calibration, you can obtain the calibration certificate for your product at [ni.com/calibration](https://ni.com/calibration).

National Instruments corporate headquarters is located at 11500 North Mopac Expressway, Austin, Texas, 78759-3504. National Instruments also has offices located around the world. For telephone support in the United States, create your service request at [ni.com/support](https://ni.com/support) or dial 1 866 ASK MYNI (275 6964). For telephone support outside the United States, visit the *Worldwide Offices* section of [ni.com/niglobal](https://ni.com/niglobal) to access the branch office websites, which provide up-to-date contact information, support phone numbers, email addresses, and current events.

Refer to the *NI Trademarks and Logo Guidelines* at [ni.com/trademarks](https://ni.com/trademarks) for information on National Instruments trademarks. Other product and company names mentioned herein are trademarks or trade names of their respective companies. For patents covering National Instruments products/technology, refer to the appropriate location: **Help»Patents** in your software, the `patents.txt` file on your media, or the *National Instruments Patent Notice* at [ni.com/patents](https://ni.com/patents). You can find information about end-user license agreements (EULAs) and third-party legal notices in the `readme` file for your NI product. Refer to the *Export Compliance Information* at [ni.com/legal/export-compliance](https://ni.com/legal/export-compliance) for the National Instruments global trade compliance policy and how to obtain relevant HTS codes, ECCNs, and other import/export data. NI MAKES NO EXPRESS OR IMPLIED WARRANTIES AS TO THE ACCURACY OF THE INFORMATION CONTAINED HEREIN AND SHALL NOT BE LIABLE FOR ANY ERRORS. U.S. Government Customers: The data contained in this manual was developed at private expense and is subject to the applicable limited rights and restricted data rights as set forth in FAR 52.227-14, DFAR 252.227-7014, and DFAR 252.227-7015.

© National Instruments. All rights reserved.