

COMPREHENSIVE SERVICES

We offer competitive repair and calibration services, as well as easily accessible documentation and free downloadable resources.

SELL YOUR SURPLUS

We buy new, used, decommissioned, and surplus parts from every NI series. We work out the best solution to suit your individual needs.

 Sell For Cash  Get Credit  Receive a Trade-In Deal

OBSOLETE NI HARDWARE IN STOCK & READY TO SHIP

We stock **New**, **New Surplus**, **Refurbished**, and **Reconditioned** NI Hardware.



Bridging the gap between the manufacturer and your legacy test system.

 1-800-915-6216

 www.apexwaves.com

 sales@apexwaves.com

All trademarks, brands, and brand names are the property of their respective owners.

Request a Quote

 **CLICK HERE**

USB-6366

DAQ X Series

X Series User Manual

NI 632x/634x/635x/636x/637x/638x/639x Devices

Français

Deutsch

日本語

한국어

简体中文

ni.com/manuals

Worldwide Technical Support and Product Information

ni.com

Worldwide Offices

Visit ni.com/niglobal to access the branch office websites, which provide up-to-date contact information, support phone numbers, email addresses, and current events.

National Instruments Corporate Headquarters

11500 North Mopac Expressway Austin, Texas 78759-3504 USA Tel: 512 683 0100

For further support information, refer to the *NI Services* appendix. To comment on NI documentation, refer to the NI website at ni.com/info and enter the Info Code feedback.

© 2009–2019 National Instruments. All rights reserved.

Legal Information

Limited Warranty

This document is provided 'as is' and is subject to being changed, without notice, in future editions. For the latest version, refer to ni.com/manuals. NI reviews this document carefully for technical accuracy; however, NI MAKES NO EXPRESS OR IMPLIED WARRANTIES AS TO THE ACCURACY OF THE INFORMATION CONTAINED HEREIN AND SHALL NOT BE LIABLE FOR ANY ERRORS.

NI warrants that its hardware products will be free of defects in materials and workmanship that cause the product to fail to substantially conform to the applicable NI published specifications for one (1) year from the date of invoice.

For a period of ninety (90) days from the date of invoice, NI warrants that (i) its software products will perform substantially in accordance with the applicable documentation provided with the software and (ii) the software media will be free from defects in materials and workmanship.

If NI receives notice of a defect or non-conformance during the applicable warranty period, NI will, in its discretion: (i) repair or replace the affected product, or (ii) refund the fees paid for the affected product. Repaired or replaced Hardware will be warranted for the remainder of the original warranty period or ninety (90) days, whichever is longer. If NI elects to repair or replace the product, NI may use new or refurbished parts or products that are equivalent to new in performance and reliability and are at least functionally equivalent to the original part or product.

You must obtain an RMA number from NI before returning any product to NI. NI reserves the right to charge a fee for examining and testing Hardware not covered by the Limited Warranty.

This Limited Warranty does not apply if the defect of the product resulted from improper or inadequate maintenance, installation, repair, or calibration (performed by a party other than NI); unauthorized modification; improper environment; use of an improper hardware or software key; improper use or operation outside of the specification for the product; improper voltages; accident, abuse, or neglect; or a hazard such as lightning, flood, or other act of nature.

THE REMEDIES SET FORTH ABOVE ARE EXCLUSIVE AND THE CUSTOMER'S SOLE REMEDIES, AND SHALL APPLY EVEN IF SUCH REMEDIES FAIL OF THEIR ESSENTIAL PURPOSE.

EXCEPT AS EXPRESSLY SET FORTH HEREIN, PRODUCTS ARE PROVIDED "AS IS" WITHOUT WARRANTY OF ANY KIND AND NI DISCLAIMS ALL WARRANTIES, EXPRESSED OR IMPLIED, WITH RESPECT TO THE PRODUCTS, INCLUDING ANY IMPLIED WARRANTIES OF MERCHANTABILITY, FITNESS FOR A PARTICULAR PURPOSE, TITLE OR NON-INFRINGEMENT, AND ANY WARRANTIES THAT MAY ARISE FROM USAGE OF TRADE OR COURSE OF DEALING. NI DOES NOT WARRANT, GUARANTEE, OR MAKE ANY REPRESENTATIONS REGARDING THE USE OF OR THE RESULTS OF THE USE OF THE PRODUCTS IN TERMS OF CORRECTNESS, ACCURACY, RELIABILITY, OR OTHERWISE. NI DOES NOT WARRANT THAT THE OPERATION OF THE PRODUCTS WILL BE UNINTERRUPTED OR ERROR FREE.

In the event that you and NI have a separate signed written agreement with warranty terms covering the products, then the warranty terms in the separate agreement shall control.

Copyright

Under the copyright laws, this publication may not be reproduced or transmitted in any form, electronic or mechanical, including photocopying, recording, storing in an information retrieval system, or translating, in whole or in part, without the prior written consent of National Instruments Corporation.

National Instruments respects the intellectual property of others, and we ask our users to do the same. NI software is protected by copyright and other intellectual property laws. Where NI software may be used to reproduce software or other materials belonging to others, you may use NI software only to reproduce materials that you may reproduce in accordance with the terms of any applicable license or other legal restriction.

End-User License Agreements and Third-Party Legal Notices

You can find end-user license agreements (EULAs) and third-party legal notices in the following locations:

- Notices are located in the <National Instruments>_Legal Information and <National Instruments> directories.
- EULAs are located in the <National Instruments>\Shared\MDF\Legal\license directory.
- Review <National Instruments>_Legal Information.txt for information on including legal information in installers built with NI products.

U.S. Government Restricted Rights

If you are an agency, department, or other entity of the United States Government ("Government"), the use, duplication, reproduction, release, modification, disclosure or transfer of the technical data included in this manual is governed by the Restricted Rights provisions under Federal Acquisition Regulation 52.227-14 for civilian agencies and Defense Federal Acquisition Regulation Supplement Section 252.227-7014 and 252.227-7015 for military agencies.

Trademarks

Refer to the *NI Trademarks and Logo Guidelines* at ni.com/trademarks for more information on National Instruments trademarks.

ARM, Keil, and μ Vision are trademarks or registered of ARM Ltd or its subsidiaries.

LEGO, the LEGO logo, WEDO, and MINDSTORMS are trademarks of the LEGO Group.

TETRIX by Pitsco is a trademark of Pitsco, Inc.

FIELDBUS FOUNDATION™ and FOUNDATION™ are trademarks of the Fieldbus Foundation.

EtherCAT® is a registered trademark of and licensed by Beckhoff Automation GmbH.

CANopen® is a registered Community Trademark of CAN in Automation e.V.

DeviceNet™ and EtherNet/IP™ are trademarks of ODVA.

Go!, SensorDAQ, and Vernier are registered trademarks of Vernier Software & Technology. Vernier Software & Technology and vernier.com are trademarks or trade dress.

Xilinx is the registered trademark of Xilinx, Inc.

Taptite and Trilobular are registered trademarks of Research Engineering & Manufacturing Inc.

FireWire® is the registered trademark of Apple Inc.

Linux® is the registered trademark of Linus Torvalds in the U.S. and other countries.

Handle Graphics®, MATLAB®, Real-Time Workshop®, Simulink®, Stateflow®, and xPC TargetBox® are registered trademarks, and TargetBox™ and Target Language Compiler™ are trademarks of The MathWorks, Inc.

Tektronix®, Tek, and Tektronix, Enabling Technology are registered trademarks of Tektronix, Inc.

The Bluetooth® word mark is a registered trademark owned by the Bluetooth SIG, Inc.

The ExpressCard™ word mark and logos are owned by PCMCIA and any use of such marks by National Instruments is under license.

The mark LabWindows is used under a license from Microsoft Corporation. Windows is a registered trademark of Microsoft Corporation in the United States and other countries.

Other product and company names mentioned herein are trademarks or trade names of their respective companies.

Members of the National Instruments Alliance Partner Program are business entities independent from National Instruments and have no agency, partnership, or joint-venture relationship with National Instruments.

Patents

For patents covering National Instruments products/technology, refer to the appropriate location: **Help»Patents** in your software, the `patents.txt` file on your media, or the *National Instruments Patent Notice* at ni.com/patents.

Export Compliance Information

Refer to the *Export Compliance Information* at ni.com/legal/export-compliance for the National Instruments global trade compliance policy and how to obtain relevant HTS codes, ECCNs, and other import/export data.

WARNING REGARDING USE OF NATIONAL INSTRUMENTS PRODUCTS

YOU ARE ULTIMATELY RESPONSIBLE FOR VERIFYING AND VALIDATING THE SUITABILITY AND RELIABILITY OF THE PRODUCTS WHENEVER THE PRODUCTS ARE INCORPORATED IN YOUR SYSTEM OR APPLICATION, INCLUDING THE APPROPRIATE DESIGN, PROCESS, AND SAFETY LEVEL OF SUCH SYSTEM OR APPLICATION.

PRODUCTS ARE NOT DESIGNED, MANUFACTURED, OR TESTED FOR USE IN LIFE OR SAFETY CRITICAL SYSTEMS, HAZARDOUS ENVIRONMENTS OR ANY OTHER ENVIRONMENTS REQUIRING FAIL-SAFE PERFORMANCE, INCLUDING IN THE OPERATION OF NUCLEAR FACILITIES; AIRCRAFT NAVIGATION; AIR TRAFFIC CONTROL SYSTEMS; LIFE SAVING OR LIFE SUSTAINING SYSTEMS OR SUCH OTHER MEDICAL DEVICES; OR ANY OTHER APPLICATION IN WHICH THE FAILURE OF THE PRODUCT OR SERVICE COULD LEAD TO DEATH, PERSONAL INJURY, SEVERE PROPERTY DAMAGE OR ENVIRONMENTAL HARM (COLLECTIVELY, "HIGH-RISK USES"). FURTHER, PRUDENT STEPS MUST BE TAKEN TO PROTECT AGAINST FAILURES, INCLUDING PROVIDING BACK-UP AND SHUT-DOWN MECHANISMS. NI EXPRESSLY DISCLAIMS ANY EXPRESS OR IMPLIED WARRANTY OF FITNESS OF THE PRODUCTS OR SERVICES FOR HIGH-RISK USES.

Contents

Chapter 1

Getting Started

Safety Guidelines.....	1-1
Electromagnetic Compatibility Guidelines	1-2
Hardware Symbol Definitions	1-2
Installation	1-3
Unpacking.....	1-3
Device Self-Calibration	1-4
Getting Started with X Series USB Devices	1-5
USB Device Chassis Ground.....	1-5
Ferrite Installation.....	1-6
Mounting NI USB X Series Devices	1-7
Panel/Wall Mounting.....	1-7
DIN Rail Mounting.....	1-8
USB Device LEDs.....	1-9
USB Cable Strain Relief.....	1-9
USB Device Security Cable Slot.....	1-10
Device Pinouts	1-10
Device Specifications	1-10
Device Accessories and Cables	1-10

Chapter 2

DAQ System Overview

DAQ Hardware.....	2-2
DAQ-STC3	2-2
Calibration Circuitry.....	2-3
Cables and Accessories	2-3
PCI Express, PXI Express, and USB Mass Termination Device Cables and Accessories	2-4
SCXI Accessories	2-4
SCC Accessories.....	2-4
BNC Accessories.....	2-5
Screw Terminal Accessories	2-6
RTSI Cables.....	2-6
Cables	2-6
Custom Cabling and Connectivity.....	2-7
USB Device Accessories, USB Cable, Power Supply, and Ferrite.....	2-7

Signal Conditioning 2-8

- Sensors and Transducers 2-8
- Signal Conditioning Options 2-9
 - SCXI 2-9
 - SCC 2-9

Programming Devices in Software 2-10

Chapter 3 Connector and LED Information

I/O Connector Signal Descriptions 3-2

+5 V Power Source 3-5

USER 1 and USER 2 3-5

PCI Express Device Disk Drive Power Connector 3-6

- When to Use the Disk Drive Power Connector 3-6
- Disk Drive Power Connector Installation 3-6

RTSI Connector Pinout 3-7

USB Device LED Patterns 3-7

Chapter 4 Analog Input

Analog Input on MIO X Series Devices 4-1

- Analog Input Range 4-2
- Working Voltage Range 4-3
- Analog Input Ground-Reference Settings 4-4
 - Configuring AI Ground-Reference Settings in Software 4-6
- Multichannel Scanning Considerations 4-6
- Analog Input Data Acquisition Methods 4-9
 - Software-Timed Acquisitions 4-9
 - Hardware-Timed Acquisitions 4-9
- Analog Input Triggering 4-10
- Connecting Analog Input Signals 4-10
- Connecting Floating Signal Sources 4-12
 - What Are Floating Signal Sources? 4-12
 - When to Use Differential Connections with Floating Signal Sources 4-12
 - When to Use Non-Referenced Single-Ended (NRSE) Connections
 - with Floating Signal Sources 4-12
 - When to Use Referenced Single-Ended (RSE) Connections
 - with Floating Signal Sources 4-13
 - Using Differential Connections for Floating Signal Sources 4-13
 - Using Non-Referenced Single-Ended (NRSE) Connections
 - for Floating Signal Sources 4-16
 - Using Referenced Single-Ended (RSE) Connections
 - for Floating Signal Sources 4-17

Connecting Ground-Referenced Signal Sources	4-17
What Are Ground-Referenced Signal Sources?	4-17
When to Use Differential Connections with Ground-Referenced Signal Sources	4-18
When to Use Non-Referenced Single-Ended (NRSE) Connections with Ground-Referenced Signal Sources	4-18
When to Use Referenced Single-Ended (RSE) Connections with Ground-Referenced Signal Sources	4-19
Using Differential Connections for Ground-Referenced Signal Sources	4-19
Using Non-Referenced Single-Ended (NRSE) Connections for Ground-Referenced Signal Sources	4-20
Field Wiring Considerations	4-21
Analog Input Timing Signals	4-22
Aggregate versus Single Channel Sample Rates	4-24
AI Sample Clock Signal	4-24
AI Sample Clock Timebase Signal	4-26
AI Convert Clock Signal	4-27
AI Convert Clock Timebase Signal	4-30
AI Hold Complete Event Signal	4-30
AI Start Trigger Signal	4-30
AI Reference Trigger Signal	4-32
AI Pause Trigger Signal	4-34
Getting Started with AI Applications in Software	4-35
Analog Input on Simultaneous MIO X Series Devices	4-36
Analog Input Terminal Configuration	4-37
Analog Input Range	4-37
Working Voltage Range	4-38
Analog Input Data Acquisition Methods	4-38
Analog Input Triggering	4-40
Connecting Analog Input Signals	4-41
Types of Signal Sources	4-41
Differential Connections for Ground-Referenced Signal Sources	4-42
Differential Connections for Floating Signal Sources	4-43
Unused Channels	4-44
Field Wiring Considerations	4-44
Minimizing Drift in Differential Mode	4-45
Analog Input Timing Signals	4-45
Aggregate versus Single Channel Sample Rates	4-47
AI Sample Clock Signal	4-48
AI Sample Clock Timebase Signal	4-49
AI Hold Complete Event Signal	4-50
AI Start Trigger Signal	4-50
AI Reference Trigger Signal	4-53
AI Pause Trigger Signal	4-54
Getting Started with AI Applications in Software	4-56

Chapter 5

Analog Output

AO Reference Selection.....	5-2
Minimizing Glitches on the Output Signal	5-2
Analog Output Data Generation Methods	5-3
Software-Timed Generations	5-3
Hardware-Timed Generations.....	5-3
Analog Output Triggering	5-4
Connecting Analog Output Signals	5-5
Analog Output Timing Signals	5-5
AO Start Trigger Signal.....	5-6
Retriggerable Analog Output.....	5-6
Using a Digital Source.....	5-6
Using an Analog Source	5-7
Routing AO Start Trigger Signal to an Output Terminal	5-7
AO Pause Trigger Signal	5-7
Using a Digital Source.....	5-8
Using an Analog Source	5-8
Routing AO Pause Trigger Signal to an Output Terminal.....	5-8
AO Sample Clock Signal.....	5-8
Using an Internal Source.....	5-8
Using an External Source	5-9
Routing AO Sample Clock Signal to an Output Terminal	5-9
Other Timing Requirements	5-9
AO Sample Clock Timebase Signal	5-10
Getting Started with AO Applications in Software	5-11

Chapter 6

Digital I/O

Digital Input Data Acquisition Methods.....	6-2
Software-Timed Acquisitions.....	6-2
Hardware-Timed Acquisitions.....	6-2
Digital Input Triggering.....	6-3
Digital Waveform Acquisition.....	6-4
DI Sample Clock Signal	6-4
Using an Internal Source.....	6-5
Using an External Source	6-5
Routing DI Sample Clock to an Output Terminal	6-5
Other Timing Requirements	6-5
DI Sample Clock Timebase Signal.....	6-6
DI Start Trigger Signal	6-7
Retriggerable DI	6-7
Using a Digital Source.....	6-7

Using an Analog Source.....	6-8
Routing DI Start Trigger to an Output Terminal.....	6-8
DI Reference Trigger Signal.....	6-8
Using a Digital Source.....	6-9
Using an Analog Source.....	6-9
Routing DI Reference Trigger Signal to an Output Terminal.....	6-9
DI Pause Trigger Signal.....	6-10
Using a Digital Source.....	6-10
Using an Analog Source.....	6-10
Routing DI Pause Trigger Signal to an Output Terminal.....	6-11
Digital Output Data Generation Methods.....	6-11
Software-Timed Generations.....	6-11
Hardware-Timed Generations.....	6-11
Digital Output Triggering.....	6-12
Digital Waveform Generation.....	6-13
DO Sample Clock Signal.....	6-13
Using an Internal Source.....	6-13
Using an External Source.....	6-14
Routing DO Sample Clock to an Output Terminal.....	6-14
Other Timing Requirements.....	6-14
DO Sample Clock Timebase Signal.....	6-15
DO Start Trigger Signal.....	6-15
Retriggerable DO.....	6-15
Using a Digital Source.....	6-16
Using an Analog Source.....	6-16
Routing DO Start Trigger Signal to an Output Terminal.....	6-16
DO Pause Trigger Signal.....	6-16
Using a Digital Source.....	6-17
Using an Analog Source.....	6-18
Routing DO Pause Trigger Signal to an Output Terminal.....	6-18
I/O Protection.....	6-18
Programmable Power-Up States.....	6-18
DI Change Detection.....	6-19
DI Change Detection Applications.....	6-20
Digital Filtering.....	6-20
Watchdog Timer.....	6-23
Connecting Digital I/O Signals.....	6-24
Getting Started with DIO Applications in Software.....	6-25

Chapter 7

Counters

Counter Timing Engine	7-2
Counter Input Applications.....	7-3
Counting Edges.....	7-3
Single Point (On-Demand) Edge Counting	7-4
Buffered (Sample Clock) Edge Counting.....	7-4
Controlling the Direction of Counting.....	7-5
Pulse-Width Measurement.....	7-5
Single Pulse-Width Measurement	7-6
Implicit Buffered Pulse-Width Measurement.....	7-6
Sample Clocked Buffered Pulse-Width Measurement	7-7
Hardware-Timed Single Point Pulse-Width Measurement	7-7
Pulse Measurement	7-8
Single Pulse Measurement.....	7-8
Implicit Buffered Pulse Measurement	7-8
Sample Clocked Buffered Pulse Measurement	7-9
Hardware-Timed Single Point Pulse Measurement.....	7-9
Pulse versus Semi-Period Measurements	7-10
Semi-Period Measurement.....	7-10
Single Semi-Period Measurement	7-11
Implicit Buffered Semi-Period Measurement.....	7-11
Frequency Measurement.....	7-11
Low Frequency with One Counter.....	7-12
High Frequency with Two Counters.....	7-12
Large Range of Frequencies with Two Counters	7-13
Sample Clocked Buffered Frequency Measurement	7-14
Hardware-Timed Single Point Frequency Measurement.....	7-16
Choosing a Method for Measuring Frequency	7-16
Period Measurement	7-20
Position Measurement.....	7-21
Measurements Using Quadrature Encoders.....	7-21
Measurements Using Two Pulse Encoders.....	7-23
Buffered (Sample Clock) Position Measurement	7-23
Hardware-Timed Single Point Position Measurement	7-24
Two-Signal Edge-Separation Measurement	7-24
Single Two-Signal Edge-Separation Measurement.....	7-24
Implicit Buffered Two-Signal Edge-Separation Measurement	7-25
Sample Clocked Buffered Two-Signal Separation Measurement	7-25
Hardware-Timed Single Point Two-Signal Separation Measurement	7-26
Counter Output Applications.....	7-26
Simple Pulse Generation.....	7-27
Single Pulse Generation.....	7-27
Single Pulse Generation with Start Trigger	7-27

Pulse Train Generation	7-28
Finite Pulse Train Generation.....	7-28
Retriggerable Pulse or Pulse Train Generation	7-29
Continuous Pulse Train Generation.....	7-30
Buffered Pulse Train Generation.....	7-31
Finite Implicit Buffered Pulse Train Generation.....	7-31
Continuous Buffered Implicit Pulse Train Generation.....	7-32
Finite Buffered Sample Clocked Pulse Train Generation	7-32
Continuous Buffered Sample Clocked Pulse Train Generation	7-33
Frequency Generation.....	7-34
Using the Frequency Generator.....	7-34
Frequency Division.....	7-35
Pulse Generation for ETS	7-35
Counter Timing Signals.....	7-36
Counter <i>n</i> Source Signal.....	7-36
Routing a Signal to Counter <i>n</i> Source	7-37
Routing Counter <i>n</i> Source to an Output Terminal.....	7-37
Counter <i>n</i> Gate Signal.....	7-37
Routing a Signal to Counter <i>n</i> Gate.....	7-38
Routing Counter <i>n</i> Gate to an Output Terminal	7-38
Counter <i>n</i> Aux Signal	7-38
Routing a Signal to Counter <i>n</i> Aux	7-38
Counter <i>n</i> A, Counter <i>n</i> B, and Counter <i>n</i> Z Signals	7-39
Routing Signals to A, B, and Z Counter Inputs.....	7-39
Routing Counter <i>n</i> Z Signal to an Output Terminal	7-39
Counter <i>n</i> Up_Down Signal	7-39
Counter <i>n</i> HW Arm Signal.....	7-39
Routing Signals to Counter <i>n</i> HW Arm Input	7-40
Counter <i>n</i> Sample Clock Signal.....	7-40
Using an Internal Source	7-40
Using an External Source	7-41
Routing Counter <i>n</i> Sample Clock to an Output Terminal	7-41
Counter <i>n</i> Internal Output and Counter <i>n</i> TC Signals	7-41
Routing Counter <i>n</i> Internal Output to an Output Terminal	7-41
Frequency Output Signal.....	7-41
Routing Frequency Output to a Terminal.....	7-41
Default Counter/Timer Pins.....	7-42
Counter Triggering	7-45
Other Counter Features.....	7-45
Cascading Counters	7-45
Prescaling.....	7-46
Synchronization Modes	7-46
100 MHz Source Mode.....	7-47
External Source Greater than 25 MHz	7-47
External or Internal Source Less than 25 MHz	7-47

Chapter 8 PFI

Using PFI Terminals as Timing Input Signals.....	8-2
Exporting Timing Output Signals Using PFI Terminals	8-2
Using PFI Terminals as Static Digital I/Os	8-3
Using PFI Terminals to Digital Detection Events	8-4
Connecting PFI Input Signals	8-4
PFI Filters	8-4
I/O Protection.....	8-6
Programmable Power-Up States	8-6

Chapter 9 Digital Routing and Clock Generation

Clock Routing	9-1
100 MHz Timebase.....	9-2
20 MHz Timebase.....	9-2
100 kHz Timebase	9-2
External Reference Clock	9-2
10 MHz Reference Clock	9-3
Synchronizing Multiple Devices	9-3
PXI Express Devices	9-3
PCI Express Devices.....	9-3
USB Devices	9-4
Real-Time System Integration (RTSI).....	9-4
RTSI Connector Pinout.....	9-5
Using RTSI as Outputs	9-6
Using RTSI Terminals as Timing Input Signals.....	9-6
RTSI Filters.....	9-7
PXI and PXI Express Clock and Trigger Signals	9-7
PXIe_CLK100	9-7
PXIe_SYNC100.....	9-7
PXI_CLK10	9-8
PXI Triggers	9-8
PXI_STAR Trigger.....	9-8
PXI_STAR Filters.....	9-8
PXIe_DSTAR<A..C>	9-9

Chapter 10 Bus Interface

Data Transfer Methods	10-1
PCI Express/PXI Express Device Data Transfer Methods	10-1
USB Device Data Transfer Methods	10-2
PXI Express Considerations	10-3
PXI and PXI Express Clock and Trigger Signals	10-3

PXI Express	10-3
PXIe DAQ Bandwidth Considerations	10-3
USB DAQ Bandwidth Considerations	10-3
Data Throughput	10-4

Chapter 11

Triggering

Triggering with a Digital Source	11-1
Triggering with an Analog Source	11-2
APFI <0,1> Terminals	11-2
Analog Input Channels	11-3
Analog Input Channels on MIO X Series Devices	11-3
Analog Input Channels on Simultaneous MIO X Series Devices	11-3
Analog Trigger Actions	11-3
Routing Analog Comparison Event to an Output Terminal	11-4
Analog Trigger Types	11-4
Analog Trigger Accuracy	11-6

Appendix A

Device-Specific Information

Appendix B

Where to Go from Here

Appendix C

Troubleshooting

Appendix D

NI Services

Index

List of Figures

Figure A-1.	NI PCIe-6320 Pinout	A-2
Figure A-2.	NI PCIe-6321 and NI PCIe/PXIe-6341 Pinout	A-4
Figure A-3.	NI USB-6341 Screw Terminal Pinout	A-5
Figure A-4.	NI USB-6341 BNC Pinout	A-6
Figure A-5.	NI PCIe-6323/6343 Pinout	A-8
Figure A-6.	NI USB-6343 Screw Terminal Pinout	A-9
Figure A-7.	NI USB-6343 BNC Pinout	A-10
Figure A-8.	NI PXIe-6345/6355 Pinout	A-12
Figure A-9.	NI PCIe-6346 Pinout	A-14
Figure A-10.	NI USB 6346 Screw Terminal Pinout	A-15

Contents

Figure A-11.	NI USB 6346 BNC Pinout.....	A-16
Figure A-12.	NI PXIe-6349 Pinout.....	A-18
Figure A-13.	NI USB-6349 Screw Terminal Pinout.....	A-19
Figure A-14.	NI PCIe-6351 and NI PCIe/PXIe-6361 Pinout.....	A-21
Figure A-15.	NI USB-6351/6361 Screw Terminal Pinout.....	A-22
Figure A-16.	NI USB-6361 Mass Termination Pinout.....	A-23
Figure A-17.	NI USB-6361 BNC Pinout.....	A-25
Figure A-18.	NI PCIe-6353 and NI PCIe/PXIe-6363 Pinout.....	A-27
Figure A-19.	NI USB-6363 Mass Termination Pinout.....	A-28
Figure A-20.	NI USB-6353/6363 Screw Terminal Pinout.....	A-30
Figure A-21.	NI USB-6363 Pinout.....	A-31
Figure A-22.	NI PXIe-PXIe-6356/6366/6386/6396 and PCIe/PXIe-6376 Pinout.....	A-33
Figure A-23.	NI USB-6366 Mass Termination Pinout.....	A-35
Figure A-24.	NI USB-6356/6366 Screw Terminal Pinout.....	A-36
Figure A-25.	NI USB-6356/6366 BNC Pinout.....	A-37
Figure A-26.	NI PXIe-6358/6368/6378 Pinout.....	A-39
Figure A-27.	NI PXIe-6365 Connector 2 Pinout.....	A-41
Figure A-28.	NI PXIe-6365 Connector 0 and Connector 1 Pinout.....	A-42
Figure A-29.	NI PCIe-6374 Pinout.....	A-44
Figure A-30.	NI PXIe-6375 Connector 2 and Connector 3 Pinout.....	A-46
Figure A-31.	NI PXIe-6375 Connector 0 and Connector 1 Pinout.....	A-47

Getting Started

The X Series User Manual contains information about using the National Instruments X Series data acquisition (DAQ) devices with NI-DAQmx 19.0 and later. X Series devices feature up to 208 analog input (AI) channels, up to four analog output (AO) channels, up to 48 lines of digital input/output (DIO), and four counters. This chapter provides basic information you need to get started using your X Series device.

Safety Guidelines

Operate the NI 63xx X Series devices and modules only as described in this user manual.



Caution NI 63xx devices and modules are *not* certified for use in hazardous locations.



Caution *Never* connect the +5 V power terminals to analog or digital ground or to any other voltage source on the X series device or any other device. Doing so can damage the device and the computer. NI is not liable for damage resulting from such a connection.



Caution The maximum input voltages rating of AI signals with respect to ground (and for signal pairs in differential mode with respect to each other) are listed in the specifications document for your device. Exceeding the maximum input voltage of AI signals distorts the measurement results. Exceeding the maximum input voltage rating also can damage the device and the computer. NI is not liable for any damage resulting from such signal connections.



Caution Exceeding the maximum input voltage ratings, which are listed in the specifications document for each X Series device, can damage the DAQ device and the computer. NI is not liable for any damage resulting from such signal connections.

Electromagnetic Compatibility Guidelines

This product was tested and complies with the regulatory requirements and limits for electromagnetic compatibility (EMC) as stated in the product specifications. These requirements and limits are designed to provide reasonable protection against harmful interference when the product is operated in its intended operational electromagnetic environment.

This product is intended for use in industrial locations. There is no guarantee that harmful interference will not occur in a particular installation, when the product is connected to a test object, or if the product is used in residential areas. To minimize the potential for the product to cause interference to radio and television reception or to experience unacceptable performance degradation, install and use this product in strict accordance with the instructions in the product documentation.

Furthermore, any changes or modifications to the product not expressly approved by National Instruments could void your authority to operate it under your local regulatory rules.



Notice To ensure the specified EMC performance, product installation requires either special considerations or user-installed, add-on devices. Refer to the product installation instructions for further information.



Notice For compliance with Electromagnetic Compatibility (EMC) requirements, this product must be operated with shielded cables and accessories. If unshielded cables or accessories are used, the EMC specifications are no longer guaranteed unless all unshielded cables and/or accessories are installed in a shielded enclosure with properly designed and shielded input/output ports.



Notice This product may become more sensitive to electromagnetic disturbances in the operational environment when test leads are attached or when connected to a test object.

Hardware Symbol Definitions

The following symbols are marked on your device or module.



Caution When this symbol is marked on a product, refer to the *Safety Guidelines* section for information about precautions to take.



EU Customers At the end of the product life cycle, all products *must* be sent to a WEEE recycling center. For more information about WEEE recycling centers, National Instruments WEEE initiatives, and compliance with WEEE Directive 2002/96/EC on Waste and Electronic Equipment, visit ni.com/environment/weee.



中国客户 National Instruments 符合中国电子信息产品中限制使用某些有害物质指令 (RoHS)。关于 National Instruments 中国 RoHS 合规性信息, 请登录 ni.com/environment/rohs_china。 (For information about China RoHS compliance, go to ni.com/environment/rohs_china.)

Installation

Before installing your DAQ device, you must install the software you plan to use with the device.

1. **Installing application software**—Refer to the installation instructions that accompany your software.
2. **Installing NI-DAQmx**—The *DAQ Getting Started* guides, packaged with NI-DAQmx and also on ni.com/manuals, contain step-by-step instructions for installing software and hardware, configuring channels and tasks, and getting started developing an application.
3. **Installing the hardware**—Unpack your X Series device as described in the [Unpacking](#) section. The *DAQ Getting Started* guides describe how to install PCI Express, PXI Express, and USB devices, as well as accessories and cables.

Unpacking

The X Series device ships in an antistatic package to prevent electrostatic discharge (ESD). ESD can damage several components on the device.



Caution *Never* touch the exposed pins of connectors.

To avoid ESD damage in handling the device, take the following precautions:

- Ground yourself with a grounding strap or by touching a grounded object.
- Touch the antistatic package to a metal part of your computer chassis before removing the device from the package.

Remove the device from the package and inspect it for loose components or any other signs of damage. Notify NI if the device appears damaged in any way. Do not install a damaged device in your computer or chassis.

Store the device in the antistatic package when the device is not in use.

Device Self-Calibration

NI recommends that you self-calibrate your X Series device after installation and whenever the ambient temperature changes. Self-calibration should be performed after the device has warmed up for the recommended time period. Refer to the device specifications to find your device warm-up time. This function measures the onboard reference voltage of the device and adjusts the self-calibration constants to account for any errors caused by short-term fluctuations in the environment.

You can initiate self-calibration using Measurement & Automation Explorer (MAX), by completing the following steps.



Note Disconnect all external signals before beginning self-calibration.

1. Launch MAX.
2. Select **My System»Devices and Interfaces»your device**.
3. Initiate self-calibration using one of the following methods:
 - Click **Self-Calibrate** in the upper right corner of MAX.
 - Right-click the name of the device in the MAX configuration tree and select **Self-Calibrate** from the drop-down menu.



Note You can also programmatically self-calibrate your device with NI-DAQmx, as described in *Device Calibration* in the *NI-DAQmx Help* or the *LabVIEW Help*.

Getting Started with X Series USB Devices

The following sections contain information about X Series USB device best practices and features.

USB Device Chassis Ground

(NI USB-63xx Screw Terminal Devices) For EMC compliance, the chassis of the USB Screw Terminal X Series device *must* be connected to earth ground through the chassis ground.

The wire should be AWG 16 or larger solid copper wire with a maximum length of 1.5 m (5 ft). Attach the wire to the earth ground of the facility's power system. For more information about earth ground connections, refer to the document, *Grounding for Test and Measurement Devices*, by going to ni.com/info and entering the Info Code `emcground`.

You can attach and solder a wire to the chassis ground lug of the USB X Series device, as shown in Figure 1-1. The wire should be as short as possible.

Figure 1-1. Grounding an NI Screw Terminal USB-63xx Device through the Chassis Ground Lug

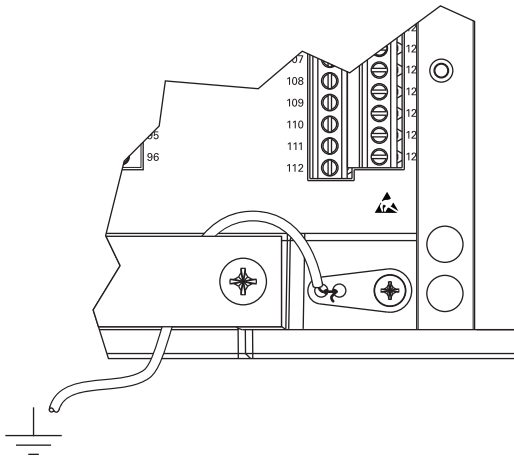

(NI USB-63xx BNC Devices) You can attach a wire to a CHS GND screw terminal of any NI BNC USB-63xx device. Use as short a wire as possible. In addition, the wires in the shielded cable that extend beyond the shield should be as short as possible.



Note (NI USB-636x Mass Termination Devices) USB Mass Termination X Series devices have chassis ground connection through the I/O connector.

Ferrite Installation

(NI USB-63xx Mass Termination and BNC Devices) To ensure the specified EMC performance for radiated RF emissions of the NI USB-63xx Mass Termination and BNC device, install the included snap-on ferrite bead onto the power cable, as shown in Figure 1-2.

Ensure that the ferrite bead is as close to the end of the power cable as practical. Install the snap-on ferrite bead by opening the housing and looping the power cable once through the center of the ferrite. Close the ferrite bead until the locking tabs engage securely.

You can order additional EMI suppression ferrites, 10.2 mm length (part number 781233-02) from NI.

Figure 1-2. Installing a Ferrite on an NI USB-63xx Mass Termination/BNC Device

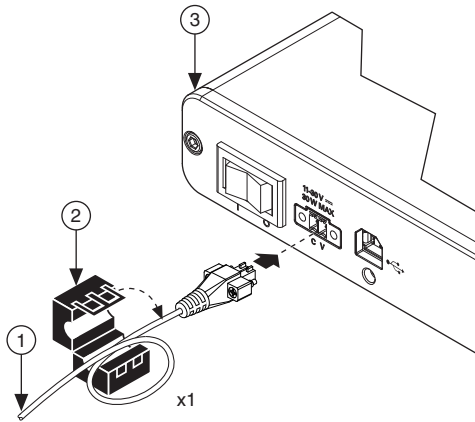

-
- | | | | | | |
|---|-------------|---|---------|---|------------------------|
| 1 | Power Cable | 2 | Ferrite | 3 | NI USB X Series Device |
|---|-------------|---|---------|---|------------------------|
-

Mounting NI USB X Series Devices

(NI USB-63xx Screw Terminal/Mass Termination Devices) You can use your NI USB X Series device on a desktop, mount it to a wall or panel as described in the [Panel/Wall Mounting](#) section, or mount it to a standard DIN rail as described in the [DIN Rail Mounting](#) section.

Panel/Wall Mounting

Complete the following steps to mount your NI USB X Series device to a wall or panel using the USB X Series mounting kit (part number 781514-01 not included in your USB X Series device kit). Refer to Figure 1-3.

1. Use three #8-32 flathead screws to attach the backpanel wall mount to the panel/wall. Tighten the screws with a #2 Phillips screwdriver to a torque of 1.1 N · m (10 lb · in.).

Figure 1-3. Using the USB X Series Mounting Kit on a Wall or Panel

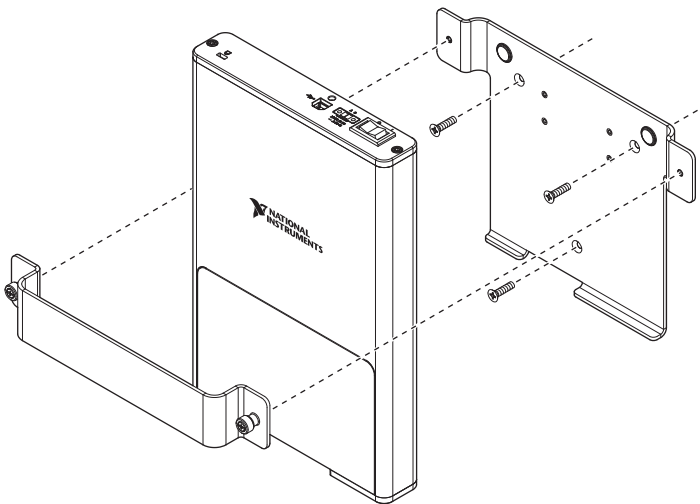

2. Place the USB X Series device on the backpanel wall mount with the signal wires facing down and the device bottom sitting on the backpanel wall mount lip.
3. While holding the USB X Series device in place, attach the front bracket to the backpanel wall mount by tightening the two thumbscrews.

DIN Rail Mounting

Complete the following steps to mount your USB X Series device to a DIN rail using the USB X Series mounting kit with DIN rail clip (part number 781515-01 not included in your USB X Series device kit).

1. Fasten the DIN rail clip to the back of the backpanel wall mount using a #1 Phillips screwdriver and four machine screws (part number 740981-01), included in the kit as shown in Figure 1-4. Tighten the screws to a torque of $0.4 \text{ N} \cdot \text{m}$ ($3.6 \text{ lb} \cdot \text{in.}$).

Figure 1-4. Attaching the DIN Rail Clip to the Backpanel Wall Mount

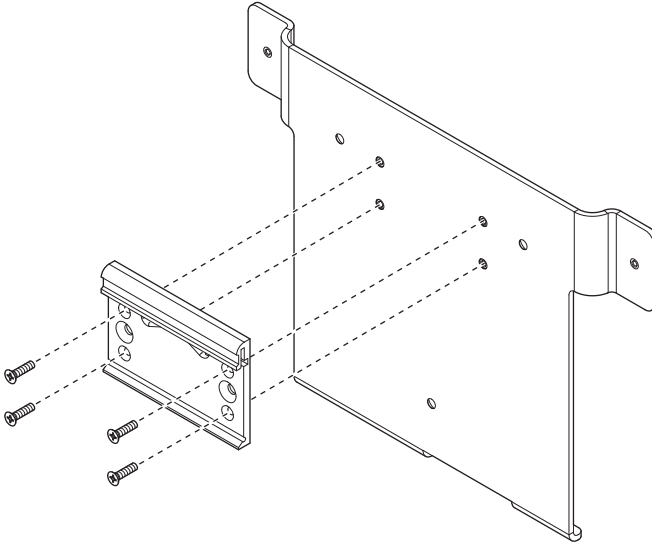

2. Clip the bracket onto the DIN rail as shown in Figure 1-5.

Figure 1-5. DIN Rail Clip Parts Locator Diagram

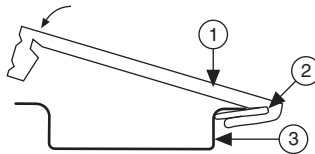

1 DIN Rail Clip

2 DIN Rail Spring

3 DIN Rail

3. Place the USB X Series device on the backpanel wall mount with the signal wires facing down and the device bottom sitting on the backpanel wall mount lip.
4. While holding the USB X Series device in place, attach the front bracket to the backpanel wall mount by tightening the two thumbscrews.

USB Device LEDs

(NI USB-63xx Devices) Refer to the *USB Device LED Patterns* section of Chapter 3, *Connector and LED Information*, for information about the USB X Series device READY and ACTIVE LEDs.

USB Cable Strain Relief

(NI USB-63xx Devices) You can provide strain relief for the USB cable by using the jackscrew on the locking USB cable (included in the USB X Series device kit) to securely attach the cable to the device, as shown in Figure 1-6.

Figure 1-6. USB Cable Strain Relief on USB X Series Devices

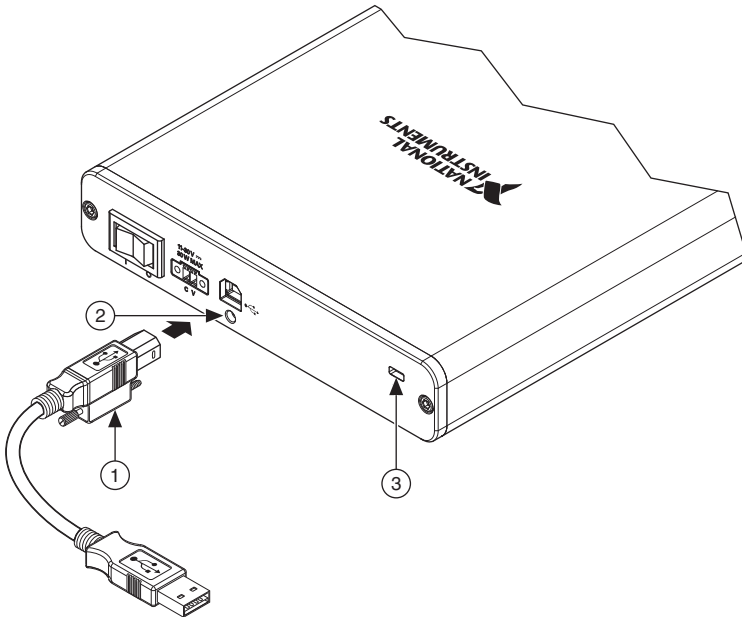

1 Locking USB Cable Jackscrew

2 Jackscrew Hole

3 Security Cable Slot

USB Device Security Cable Slot

(NI USB-63xx Devices) The security cable slot, shown in Figure 1-6, allows you to attach an optional laptop lock to your USB X Series device.



Note The security cable is designed to act as a deterrent, but might not prevent the device from being mishandled or stolen. For more information, refer to the documentation that accompanied the security cable.



Note The security cable slot on the USB device might not be compatible with all laptop lock cables.

Device Pinouts

Refer to Appendix A, *Device-Specific Information*, for X Series device pinouts.

Device Specifications

Refer to the device specifications document for your device. X Series device documentation is available on ni.com/manuals.

Device Accessories and Cables

NI offers a variety of accessories and cables to use with your DAQ device. Refer to the *Cables and Accessories* section of Chapter 2, *DAQ System Overview*, for more information.

DAQ System Overview

Figure 2-1 shows a typical DAQ system, which includes sensors, transducers, signal conditioning devices, cables that connect the various devices to the accessories, the X Series device, programming software, and PC. The following sections cover the components of a typical DAQ system.

Figure 2-1. Components of a Typical DAQ System

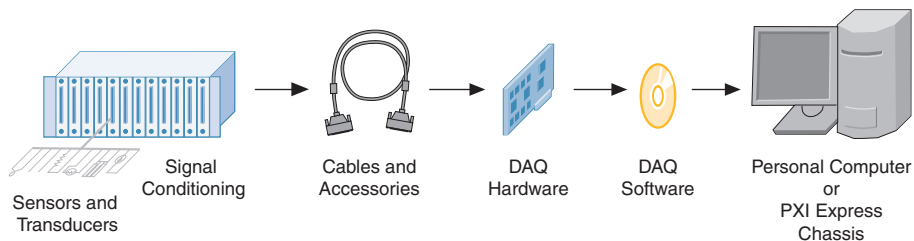

DAQ Hardware

DAQ hardware digitizes signals, performs D/A conversions to generate analog output signals, and measures and controls digital I/O signals. Figure 2-2 features components common to all X Series devices.

Figure 2-2. General X Series Block Diagram

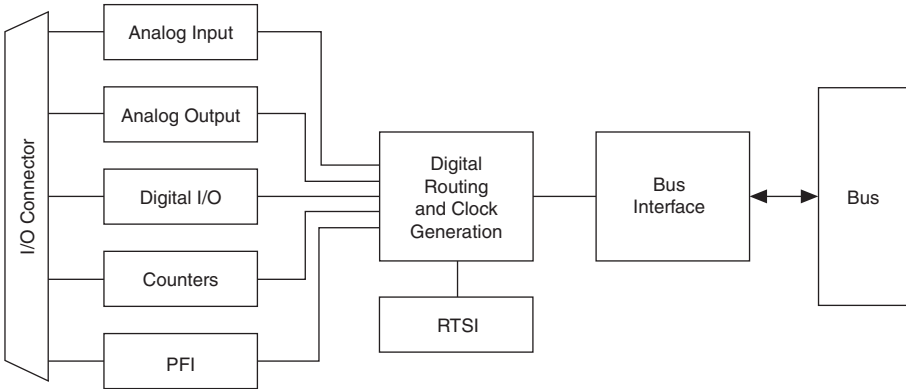

DAQ-STC3

The DAQ-STC3 and DAQ-6202 implement a high-performance digital engine for X Series data acquisition hardware. Some key features of this engine include the following:

- Flexible AI and AO sample and convert timing
- Many triggering modes
- Independent AI, AO, DI, DO, and counter FIFOs
- Generation and routing of RTSI signals for multi-device synchronization
- Generation and routing of internal and external timing signals
- Four flexible 32-bit counter/timer modules with hardware gating
- Digital waveform acquisition and generation
- Static DIO signals
- True 5 V high current drive DO
- DI change detection
- DO watchdog timers
- PLL for clock synchronization
- Seamless interface to signal conditioning accessories
- PCI Express/PXI Express interface
- Independent scatter-gather DMA controllers for all acquisition and generation functions

Calibration Circuitry

The X Series analog inputs and outputs have calibration circuitry to correct gain and offset errors. You can calibrate the device to minimize AI and AO errors caused by time and temperature drift at run time. No external circuitry is necessary; an internal reference ensures high accuracy and stability over time and temperature changes.

Factory-calibration constants are permanently stored in an onboard EEPROM and cannot be modified. When you self-calibrate the device, as described in the [Device Self-Calibration](#) section of Chapter 1, [Getting Started](#), software stores new constants in a user-modifiable section of the EEPROM. To return a device to its initial factory calibration settings, software can copy the factory-calibration constants to the user-modifiable section of the EEPROM. Refer to the [NI-DAQmx Help](#) or the [LabVIEW Help](#) for more information about using calibration constants.

For a detailed calibration procedure for X Series devices, refer to the [DAQ Multifunction I/O \(MIO\) and Simultaneous Multifunction I/O \(SMIO\) Devices Calibration Procedure](#) available at ni.com/manuals.

Cables and Accessories



Caution For compliance with Electromagnetic Compatibility (EMC) requirements, this product must be operated with shielded cables and accessories. If unshielded cables or accessories are used, the EMC specifications are no longer guaranteed unless all unshielded cables and/or accessories are installed in a shielded enclosure with properly designed and shielded input/output ports.

NI offers a variety of products to use with X Series PCI Express, PXI Express, USB devices, including cables, connector blocks, and other accessories, as follows:

- Shielded cables and cable assemblies, and unshielded ribbon cables and cable assemblies
- Screw terminal connector blocks, shielded and unshielded
- RTSI bus cables
- SCXI modules and accessories for isolating, amplifying, exciting, and multiplexing signals; with SCXI you can condition and acquire up to 3,072 channels
- Low-channel-count signal conditioning modules, devices, and accessories, including conditioning for strain gauges and RTDs, simultaneous sample and hold circuitry, and relays

For more specific information about these products, refer to the document, [63xx Models : DAQ Multifunction I/O Cable and Accessory Compatibility](#), available at ni.com/manuals.

Refer to the [Custom Cabling and Connectivity](#) section of this chapter and the [Field Wiring Considerations](#) section of Chapter 4, [Analog Input](#), for information about how to select accessories for your X Series device.

PCI Express, PXI Express, and USB Mass Termination Device Cables and Accessories

This section describes some cable and accessory options for X Series devices with one, two, three, or four 68-pin connectors. Refer to ni.com for other accessory options including new devices.

SCXI Accessories

SCXI is a programmable signal conditioning system designed for measurement and automation applications. To connect your X Series device to an SCXI chassis, use the SCXI-1349 adapter and an SHC68-68-EPM cable.



Note (NI 6346/6349/6356/6358/6366/6368/6374/6376/6378 Devices) Simultaneous MIO (SMIO) X Series devices only support controlling SCXI in parallel mode.



Note (NI PXIe-6386/6396 Devices) PXIe-6386 and PXIe-6396 devices do not support SCXI. For more information about special considerations for these devices, ni.com/info and enter the Info Code `smio14ms`.

Use Connector 0 of your X Series device to control SCXI in parallel and multiplexed mode. NI-DAQmx only supports SCXI in parallel mode on Connector 1, 2, or 3.



Note When using Connector 1, 2, or 3 in parallel mode with SCXI modules that support track and hold, you must programmatically disable track and hold.

SCC Accessories

SCC provides portable, modular signal conditioning to your DAQ system. Use an SHC68-68-EPM shielded cable to connect your X Series device to an SCC module carrier, such as the following:

- SC-2345
- SC-2350
- SCC-68

You can use either connector on MIO X Series devices to control an SCC module carrier with NI-DAQmx.



Note PCI Express users should consider the power limits on certain SCC modules without an external power supply. Refer to the device specifications, and the [PCI Express Device Disk Drive Power Connector](#) section of Chapter 3, [Connector and LED Information](#), for information about power limits and increasing the current the device can supply on the +5 V terminal.



Note (NI 6346/6349/6356/6358/6366/6368/6374/6376/6378/6386/6396 Devices) Simultaneous MIO X Series devices do *not* support SCC.



Note (NI 6345/6355/6365/6375 Devices) SCC is supported only on Connector 0.

BNC Accessories

You can use the SHC68-68-EPM shielded cable, to connect your DAQ device to the BNC accessories listed in Table 2-1.

Table 2-1. BNC Accessories

BNC Accessory	Description
BNC-2110	Provides BNC connectivity to all analog signals, some digital signals, and spring terminals for other digital signals
BNC-2111*	Provides BNC connectivity to 16 single-ended analog input signals, two analog output signals, five DIO/PFI signals, and the external reference voltage for analog output
BNC-2120	Similar to the BNC-2110, and also has a built-in function generator, quadrature encoder, temperature reference, and thermocouple connector
BNC-2090A	Desktop/rack-mountable device with 22 BNCs for connecting analog, digital, and timing signals
BNC-2115 [†]	Provides BNC connectivity for 24 differential or 48 single-ended analog inputs for connectors 1, 2, or 3 of the NI 6345/6355/6365/6375 devices. This leaves 8 differential or 16 single-ended analog inputs inaccessible on connectors 1, 2, or 3. Provides BNC connectivity for 24 differential analog inputs for connector 1 of the NI 6349 device.
* The BNC-2111 cannot be used with NI 6356/6358/6366/6368/6374/6376/6378/6386/6396 SMIO X Series devices.	
[†] The BNC-2115 can only be used on connectors 1, 2, or 3 of NI 6345/6355/6365/6375 devices and connector 1 of the NI 6349 device.	

You can use one BNC accessory on connector 0 of any X Series device. An additional BNC accessory may be used on connector 1 of any X series device except the NI 6345/6349/6355/6365/6375 devices. The BNC-2115 can only be used on connectors 1, 2, or 3 of the NI 6345/6355/6365/6375 devices and connector 1 of the NI 6349 device.

Screw Terminal Accessories

National Instruments offers several styles of screw terminal connector blocks. All terminal connector blocks require a cable except the TB-2706 to connect an X Series device to a connector block, as listed in Table 2-2.

Table 2-2. Screw Terminal Accessories

Screw Terminal Accessory	Description
CB-68LP and CB-68LPR	Unshielded connector blocks
SCC-68	I/O connector block with screw terminals, general breadboard area, bus terminals, and four expansion slots for SCC signal conditioning modules.
SCB-68	Shielded connector block with temperature sensor
SCB-68A	Screw terminal block with temperature sensor
TBX-68	DIN rail-mountable connector block
TB-2706*	Front panel mounted terminal block for PXI Express X Series devices
* TB-2706 (not for use with NI 6345/6346/6349/6355/6365/6375 devices) uses Connector 0 of your PXI Express device. After a TB-2706 is installed, Connector 1 cannot be used.	

RTSI Cables

Use RTSI bus cables to connect timing and synchronization signals among PCI/PCI Express devices, such as X Series, M Series, CAN, and other measurement, vision, and motion devices. Since PXI devices use PXI backplane signals for timing and synchronization, no cables are required.

Cables

You can use the following cables:

- **SHC68-68-EPM**¹—High-performance shielded cable designed for M/X Series devices. It has individual bundles separating analog and digital signals. Each differential analog input channel is routed on an individually shielded twisted pair of wires. Analog outputs are also individually shielded.



Note The SHC68-68-EPM cable is recommended for NI 6345/6349/6355/6365/6375 connector 0, but does not work on NI 6345/6355/6365/6375 connectors 1, 2, or 3, nor NI 6349 connector 1.

- **SHC68-68**—Lower-cost shielded cable with 34 twisted pairs of wire. The cable is recommended for NI 6345/6355/6365/6375 connectors 1, 2, or 3, and NI 6349 connector 1.
- **RC68-68**—Highly-flexible unshielded ribbon cable

Custom Cabling and Connectivity

NI offers cables and accessories for many applications. However, if you want to develop your own cable, adhere to the following guidelines for best results:

- For AI signals, use shielded, twisted-pair wires for each AI pair of differential inputs. Connect the shield for each signal pair to the ground reference at the source.
- Route the analog lines separately from the digital lines.
- When using a cable shield, use separate shields for the analog and digital sections of the cable. To prevent noise when using a cable shield, use separate shields for the analog and digital sections of the cable.

For more information about the connectors used for DAQ devices, refer to the document, *NI DAQ Device Custom Cables, Replacement Connectors, and Screws*, by going to ni.com/info and entering the Info Code `rdspmb`.

CA-1000 Custom Connectivity Enclosure

The CA-1000 is a configurable enclosure that gives user-defined connectivity and flexibility through customized panelettes. Visit ni.com for more information about the CA-1000.

SHC68-C68-EPM Cable for Custom Connectivity

The SHC68-C68-EPM can be used for any device or module for which the SHC68-68-EPM is recommended. The SHC68-C68-EPM is intended for custom breakout fixtures that use the VHDCI 0.8 mm connector. All supported accessories listed in this manual feature a SCSI 0.050 D-Type connector and will not work with this cable.

USB Device Accessories, USB Cable, Power Supply, and Ferrite

NI offers a variety of products to use with the USB X Series devices, as shown in Table 2-3.

¹ NI recommends that you use the SHC68-68-EPM cable; however, an SHC68-68-EP cable works with X Series devices.

Table 2-3. USB Device Accessories, Power Supply, and Ferrite

Description	Part Number
Universal power supply with mini-combicon connector, 12 VDC, 2.5 A	781513-01
USB X Series mounting kit with DIN rail clip*	781515-01
USB X Series mounting kit*	781514-01
USB X Series lid with thumbscrew fasteners	781661-01
USB cable with locking screw, 2 m	780534-01
EMI suppression ferrites, 10.2 mm length	781233-02
* Not for use with NI USB BNC devices.	

Signal Conditioning

Most computer-based measurement systems involve plug-in data acquisition (DAQ) devices with some form of signal conditioning. Sensors and transducers usually require signal conditioning before a measurement system can effectively and accurately acquire the signal. The front-end signal conditioning system can include functions such as signal amplification, attenuation, filtering, electrical isolation, simultaneous sampling, and multiplexing. In addition, many transducers require excitation currents or voltages, bridge completion, linearization, or high amplification for proper and accurate operation.

Sensors and Transducers

Sensors generate electrical signals to measure physical phenomena, such as temperature, force, sound, or light. Strain gauges, thermocouples, thermistors, angular encoders, linear encoders, and resistance temperature detectors (RTDs) are commonly used sensors.

To measure signals from these various transducers, you must convert them into a form that a DAQ device can accept. For example, the output voltage of most thermocouples is very small and susceptible to noise. You may need to amplify or filter the thermocouple output before digitizing it. The manipulation of signals to prepare them for digitizing is called signal conditioning.

For more information about sensors, refer to the following documents:

- For general information about sensors, visit ni.com/sensors.
- If you are using LabVIEW, refer to the *LabVIEW Help* by selecting **Help»Search the LabVIEW Help** in LabVIEW and then navigate to the **Taking Measurements** book on the **Contents** tab.

- If you are using other application software, refer to *Common Sensors* in the *NI-DAQmx Help* or the *LabVIEW Help*.

Signal Conditioning Options

SCXI

SCXI is a front-end signal conditioning and switching system for various measurement devices, including X Series devices. An SCXI system consists of a rugged chassis that houses shielded signal conditioning modules that amplify, filter, isolate, and multiplex analog signals from thermocouples or other transducers. SCXI is designed for large measurement systems or systems requiring high-speed acquisition.



Note (NI 6346/6349/6356/6358/6366/6368/6374/6376/6378 Devices)

Simultaneous MIO (SMIO) X Series devices only support controlling SCXI in parallel mode.



Note (NI PXIe-6386/6396 Devices) PXIe-6386 and PXIe-6396 devices do not support SCXI. For more information about special considerations for these devices, go to ni.com/info and enter the Info Code `smio14ms`.

System features include the following:

- **Modular architecture**—Choose your measurement technology
- **Expandability**—Expand your system to 3,072 channels
- **Integration**—Combine analog input, analog output, digital I/O, and switching into a single, unified platform
- **High bandwidth**—Acquire signals at high rates
- **Connectivity**—Select from SCXI modules with thermocouple connectors or terminal blocks

SCC

SCC is a front-end signal conditioning system for X Series plug-in data acquisition devices. An SCC system consists of a shielded carrier that holds up to 20 single- or dual-channel SCC modules for conditioning thermocouples and other transducers. SCC is designed for small measurement systems where you need only a few channels of each signal type, or for portable applications. SCC systems also offer the most comprehensive and flexible signal connectivity options.

System features include the following:

- **Modular architecture**—Select your measurement technology on a per-channel basis
- **Small-channel systems**—Condition up to 16 analog input and eight digital I/O lines

- **Low-profile/portable**—Integrates well with other laptop computer measurement technologies
- **Connectivity**—Incorporates panelette technology to offer custom connectivity to thermocouple, BNC, LEMO™ (B Series), and MIL-Spec connectors



Note (PCI Express X Series Devices) PCI Express users should consider the power limits on certain SCC modules without an external power supply. Refer to the device specifications, and the *PCI Express Device Disk Drive Power Connector* section of Chapter 3, *Connector and LED Information*, for information about power limits and increasing the current the device can supply on the +5 V terminal.



Note (NI 6346/6349/6356/6358/6366/6368/6374/6376/6378/6386/6396 Devices) Simultaneous MIO (SMIO) X Series devices do *not* support SCC.

Programming Devices in Software

National Instruments measurement devices are packaged with NI-DAQmx driver software, an extensive library of functions and VIs you can call from your application software, such as LabVIEW or LabWindows/CVI, to program all the features of your NI measurement devices. Driver software has an application programming interface (API), which is a library of VIs, functions, classes, attributes, and properties for creating applications for your device.

X Series devices use the NI-DAQmx driver. NI-DAQmx includes a collection of programming examples to help you get started developing an application. You can modify example code and save it in an application. You can use examples to develop a new application or add example code to an existing application.

To locate LabVIEW, LabWindows/CVI, Measurement Studio, Visual Basic, and ANSI C examples, refer to the document, *Where Are NI-DAQmx Examples Installed in Windows?*, by going to ni.com/info and entering the Info Code `daqmexp`.

For additional examples, refer to ni.com/examples.

Table 2-4 lists the earliest NI-DAQmx support version for each X Series device.

Table 2-4. X Series NI-DAQmx Software Support

Device	NI-DAQmx Earliest Version Support
NI PCIe/PXIe-632x/6341/6343	NI-DAQmx 9.0
NI PCIe/PXIe-6351/6353/6361/6363	NI-DAQmx 9.0
NI PXIe-6356/6358/6366/6368	NI-DAQmx 9.0.2
NI USB-6341/6343/6351/6353/6361/6363 Screw Terminal	NI-DAQmx 9.2
NI USB-6356/6366 Screw Terminal	NI-DAQmx 9.2.1
NI USB-6361/6363 Mass Termination	NI-DAQmx 9.5
NI USB-6366 Mass Termination	NI-DAQmx 9.5
NI USB-6341/6343/6356/6361/6363/6366 BNC	NI-DAQmx 9.5
NI PXIe-6345/6355/6365/6375	NI-DAQmx 14.1
NI PXIe-6376/6378	NI-DAQmx 15.5
NI PCIe-6374/6376	NI-DAQmx 17.6
NI PXIe-6349	NI-DAQmx 18.1
NI PCIe-6346	NI-DAQmx 18.1
USB-6346/6349 Screw Terminal	NI-DAQmx 18.6
USB-6346/6349 BNC	NI-DAQmx 18.6
NI PXIe-6386/6396	NI-DAQmx 19.0

Connector and LED Information

The *I/O Connector Signal Descriptions* and *+5 V Power Source* sections contain information about X Series connector signals and power. Refer to Appendix A, *Device-Specific Information*, for device I/O connector pinouts.

The *PCI Express Device Disk Drive Power Connector* and *RTSI Connector Pinout* sections refer to X Series PCI Express device power and the RTSI connector on PCI Express devices.

The *USB Device LED Patterns* section refers to the X Series USB device READY, POWER, and ACTIVE LEDs.

I/O Connector Signal Descriptions

Table 3-1 describes the signals found on the I/O connectors. Not all signals are available on all devices.

Table 3-1. I/O Connector Signals

Signal Name	Reference	Direction	Description
AI GND	—	—	Analog Input Ground —These terminals are the reference point for single-ended AI measurements in RSE mode and the bias current return point for DIFF measurements. All three ground references—AI GND, AO GND, and D GND—are connected on the device.*
AI <0..207>	Varies	Input	<p>Analog Input Channels 0 to 207</p> <p>(MIO X Series Devices) For single-ended measurements, each signal is an analog input voltage channel. In RSE mode, AI GND is the reference for these signals. In NRSE mode, the reference for each AI <0..15> signal is AI SENSE; the reference for each AI <16..79> signal is AI SENSE 2; the reference for each AI <80..143> is AI SENSE 3; and the reference for each AI <144..207> is AI SENSE 4.</p> <p>For differential measurements on MIO X Series devices, AI 0 and AI 8 are the positive and negative inputs of differential analog input channel 0. Similarly, the following signal pairs also form differential input channels:</p> <p>AI <1,9>, AI <2,10>, AI <3,11>, AI <4,12>, AI <5,13>, AI <6,14>, AI <7,15>, AI <16,24>, AI <17,25>, AI <18,26>, AI <19,27>, AI <20,28>, AI <21,29>, AI <22,30>, AI <23,31> and so on.</p> <p>Also refer to the Connecting Ground-Referenced Signal Sources section of Chapter 4, <i>Analog Input</i>.</p> <p>(Simultaneous MIO X Series Devices) For differential measurements on Simultaneous MIO X Series devices, AI 0+ and AI 0- are the positive and negative inputs of differential analog input channel 0.</p> <p>Also refer to the Connecting Analog Input Signals section of Chapter 4, <i>Analog Input</i>.</p>

Table 3-1. I/O Connector Signals (Continued)

Signal Name	Reference	Direction	Description
AI SENSE, AI SENSE 2, AI SENSE 3, AI SENSE 4	—	Input	Analog Input Sense —In NRSE mode, the reference for each AI <0..15> signal is AI SENSE; the reference for each AI <16..31> signal is AI SENSE 2; the reference for each AI <80..143> is AI SENSE 3; and the reference for each AI <144..207> is AI SENSE 4. Also refer to the Connecting Ground-Referenced Signal Sources section of Chapter 4, Analog Input .
AO <0..3>	AO GND	Output	Analog Output Channels 0 to 3 —These terminals supply the voltage output of AO channels 0 to 3.
AO GND	—	—	Analog Output Ground —AO GND is the reference for AO <0..3>. All three ground references—AI GND, AO GND, and D GND—are connected on the device.*
D GND	—	—	Digital Ground —D GND supplies the reference for P0.<0..31>, PFI <0..15>/P1/P2, and +5 V. All three ground references—AI GND, AO GND, and D GND—are connected on the device.*
P0.<0..31>	D GND	Input or Output	Port 0 Digital I/O Channels 0 to 31 —You can individually configure each signal as an input or output.
APFI <0,1>	AO GND or AI GND	Input	Analog Programmable Function Interface Channels 0 to 1 —Each APFI signal can be used as AO external reference inputs for AO <0..3>, or as an analog trigger input. APFI <0,1> are referenced to AI GND when they are used as analog trigger inputs. APFI <0,1> are referenced to AO GND when they are used as AO external offset or reference inputs. These functions are not available on all devices. Refer to the device specifications.
+5 V	D GND	Output	+5 V Power Source —These terminals provide a fused +5 V power source. Refer to the +5 V Power Source section for more information.

Table 3-1. I/O Connector Signals (Continued)

Signal Name	Reference	Direction	Description
PFI <0..7>/ P1.<0..7> PFI <8..15>/ P2.<0..7>	D GND	Input or Output	<p>Programmable Function Interface or Digital I/O Channels 0 to 7 and Channels 8 to 15—Each of these terminals can be individually configured as a PFI terminal or a digital I/O terminal.</p> <p>As an input, each PFI terminal can be used to supply an external source for AI, AO, DI, and DO timing signals or counter/timer inputs.</p> <p>As a PFI output, you can route many different internal AI, AO, DI, or DO timing signals to each PFI terminal. You can also route the counter/timer outputs to each PFI terminal.</p> <p>As a Port 1 or Port 2 digital I/O signal, you can individually configure each signal as an input or output.</p>
NC	—	—	No connect —Do <i>not</i> connect signals to these terminals.
USER 1, USER 2	—	—	User-Defined Channels 1 and 2 —On NI USB-63xx BNC devices, the USER <1..2> BNC connectors allow you to use a BNC connector for a digital or timing I/O signal of your choice. The USER <1..2> BNC connectors are internally routed to the USER <1..2> screw terminals.
CHS GND	—	—	Chassis Ground [†] —This terminal connects to the USB-63xx BNC device metal enclosure. You can connect your cable’s shield wire to CHS GND for a ground connection.
<p>* Though AI GND, AO GND, and D GND are connected on the X Series device, each ground has a slight difference in potential.</p> <p>[†] USB-63xx Screw Terminal users can connect the shield of a shielded cable to the chassis ground lug for a ground connection. The chassis ground lug is not available on all device versions.</p>			

+5 V Power Source

The +5 V terminals on the I/O connector supply +5 V referenced to D GND. Use these terminals to power external circuitry.



Caution *Never* connect the +5 V power terminals to analog or digital ground or to any other voltage source on the X Series device or any other device. Doing so can damage the device and the computer. NI is *not* liable for damage resulting from such a connection.

The power rating on most devices is +4.75 VDC to +5.25 VDC at 1 A.

Refer to the device specifications to obtain the device power rating.



Note (PCI Express X Series Devices) Some PCI Express X Series devices supply less than 1 A of +5 V power unless you use the disk drive power connector. Refer to the [PCI Express Device Disk Drive Power Connector](#) section for more information.

USER 1 and USER 2

The USER 1 and USER 2 BNC connectors allow you to use a BNC connector for a digital or timing I/O signal of your choice. The USER 1 and USER 2 BNC connectors are routed internally to the USER 1 and USER 2 screw terminals, as shown in Figure 3-1.

Figure 3-1. USER 1 and USER 2 BNC Connections

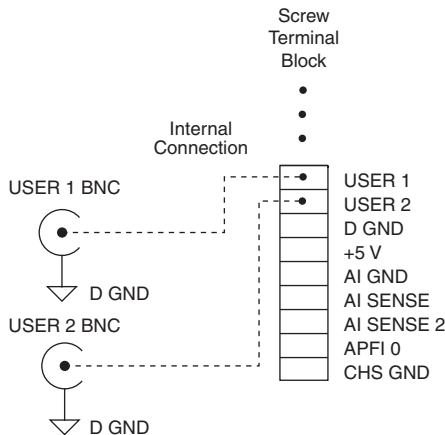

PCI Express Device Disk Drive Power Connector

(NI PCIe-632x/634x/635x/636x Devices, not including PCIe-6346) The disk drive power connector is a four-pin hard drive connector on some PCI Express devices that, when connected, increases the current the device can supply on the +5 V terminal.



Note To ensure the best performance and accuracy for the PCI Express X Series device, temperature regulation is required. For more information, refer to the document *Guidelines for Temperature Management of PCIe Devices*, by going to ni.com/info and entering info code PCIeCooling.

When to Use the Disk Drive Power Connector

PCI Express X Series devices without the disk drive power connector installed perform identically to other X Series devices for most applications and with most accessories. For most applications, it is not necessary to install the disk drive power connector.

However, you should install the disk drive power connector in either of the following situations:

- You need more power than listed in the device specifications
- You are using an accessory without an external power supply, such as the SC-2345

Refer to the device specifications for more information about PCI Express power requirements and current limits.

Disk Drive Power Connector Installation

Before installing the disk drive power connector, you must install and set up the PCI Express X Series device as described in the *DAQ Getting Started Guide for PCI/PCI Express*. Complete the following steps to install the disk drive power connector.

1. Power off and unplug the computer.
2. Remove the computer cover.
3. Attach the PC disk drive power connector to the disk drive power connector on the device, as shown in Figure 3-2.

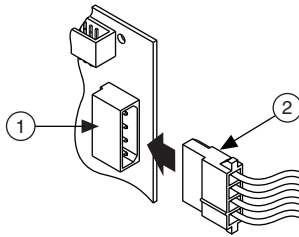

Note The power available on the disk drive power connectors in a computer can vary. For example, consider using a disk drive power connector that is not in the same power chain as the hard drive.

Figure 3-2. Connecting to the Disk Drive Power Connector

1 Device Disk Drive Power Connector

2 PC Disk Drive Power Connector

4. Replace the computer cover, and plug in and power on the computer.

RTSI Connector Pinout

(NI PCIe-632x/634x/635x/636x/637x Devices) Refer to the [RTSI Connector Pinout](#) section of Chapter 9, [Digital Routing and Clock Generation](#), for information about the RTSI connector on PCI Express X Series devices.

USB Device LED Patterns

(NI USB-634x/635x/636x Devices) USB X Series devices have LEDs labeled ACTIVE and READY. The ACTIVE LED indicates activity over the bus. The READY LED indicates whether or not the device is configured. Table 3-2 shows the behavior of the LEDs.

Table 3-2. LED Patterns

POWER LED*	ACTIVE LED	READY LED	USB Device State
Off or On	Off	Off	The device is not powered or not connected to the host computer, or the host computer does not have the correct version of NI-DAQmx. Refer to Table 2-4, X Series NI-DAQmx Software Support , for the NI-DAQmx support information for your device. Detection can take 30 to 45 seconds.
On	Off	On	The device is configured, but there is no activity over the bus.
On	On	On	The device is configured and there is activity over the bus.
On	Blinking	On	

* USB BNC devices only.

Analog Input

Refer to one of the following sections, depending on your device:

- [Analog Input on MIO X Series Devices](#)—NI 632x/6341/6343/6345/6351/6353/6355/6361/6363/6365/6375 devices can be configured for single-ended and differential analog input measurements.
- [Analog Input on Simultaneous MIO X Series Devices](#)—NI 6346/6349/6356/6358/6366/6368/6374/6376/6378/6386/6396 devices can be configured for differential analog input simultaneous sampled measurements.

Analog Input on MIO X Series Devices

Figure 4-1 shows the analog input circuitry of MIO X Series devices.

Figure 4-1. MIO X Series Analog Input Circuitry

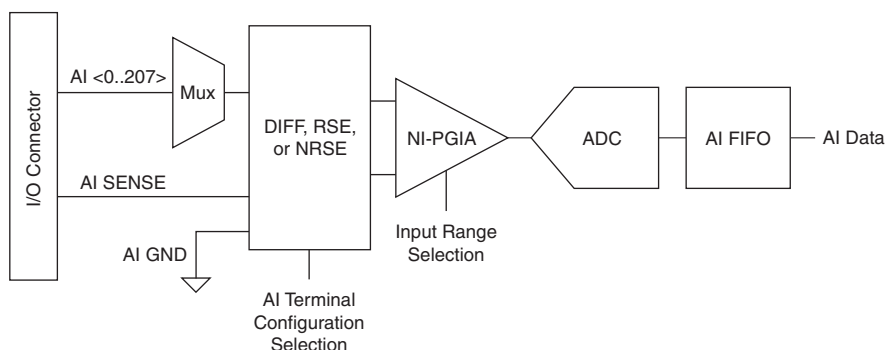

The main blocks featured in the MIO X Series device analog input circuitry are as follows:

- **I/O Connector**—You can connect analog input signals to the MIO X Series device through the I/O connector. The proper way to connect analog input signals depends on the analog input ground-reference settings, described in the [Analog Input Ground-Reference Settings](#) section. Also refer to Appendix A, [Device-Specific Information](#), for device I/O connector pinouts.
- **Mux**—Each MIO X Series device has one analog-to-digital converter (ADC). The multiplexers (mux) route one AI channel at a time to the ADC through the NI-PGIA.
- **Ground-Reference Settings**—The analog input ground-reference settings circuitry selects between differential, referenced single-ended, and non-referenced single-ended input modes. Each AI channel can use a different mode.

- **Instrumentation Amplifier (NI-PGIA)**—The NI programmable gain instrumentation amplifier (NI-PGIA) is a measurement and instrument class amplifier that minimizes settling times for all input ranges. The NI-PGIA can amplify or attenuate an AI signal to ensure that you use the maximum resolution of the ADC.
MIO X Series devices use the NI-PGIA to deliver high accuracy even when sampling multiple channels with small input ranges at fast rates. MIO X Series devices can sample channels in any order, and you can individually program each channel in a sample with a different input range.
- **A/D Converter**—The analog-to-digital converter (ADC) digitizes the AI signal by converting the analog voltage into a digital number.
- **AI FIFO**—MIO X Series devices can perform both single and multiple A/D conversions of a fixed or infinite number of samples. A large first-in-first-out (FIFO) buffer holds data during AI acquisitions to ensure that no data is lost. MIO X Series devices can handle multiple A/D conversion operations with DMA or programmed I/O.

Analog Input Range

Input range refers to the set of input voltages that an analog input channel can digitize with the specified accuracy. The NI-PGIA amplifies or attenuates the AI signal depending on the input range. You can individually program the input range of each AI channel on your MIO X Series device.

The input range affects the resolution of the MIO X Series device for an AI channel. Resolution refers to the voltage of one ADC code. For example, a 16-bit ADC converts analog inputs into one of 65,536 ($= 2^{16}$) codes—that is, one of 65,536 possible digital values. These values are spread fairly evenly across the input range. So, for an input range of -10 V to 10 V, the voltage of each code of a 16-bit ADC is:

$$\frac{10\text{V} - (-10\text{V})}{2^{16}} = 305\ \mu\text{V}$$

MIO X Series devices use a calibration method that requires some codes (typically about 5% of the codes) to lie outside of the specified range. This calibration method improves absolute accuracy, but it increases the nominal resolution of input ranges by about 5% over what the formula shown above would indicate.

Choose an input range that matches the expected input range of your signal. A large input range can accommodate a large signal variation, but reduces the voltage resolution. Choosing a smaller input range improves the voltage resolution, but may result in the input signal going out of range.

For more information about setting ranges, refer to the *NI-DAQmx Help* or the *LabVIEW Help*.

Table 4-1 shows the input ranges and resolutions supported by each MIO X Series device.

Table 4-1. MIO X Series Device Input Range and Nominal Resolution

MIO X Series Device	Input Range	Nominal Resolution Assuming 5% Over Range
NI 632x/6341/6343	-10 V to 10 V	320 μ V
	-5 V to 5 V	160 μ V
	-1 V to 1 V	32 μ V
	-200 mV to 200 mV	6.4 μ V
NI 6345/6351/6353/6355/ 6361/6363/6365/6375	-10 V to 10 V	320 μ V
	-5 V to 5 V	160 μ V
	-2 V to 2 V	64 μ V
	-1 V to 1 V	32 μ V
	-500 mV to 500 mV	16 μ V
	-200 mV to 200 mV	6.4 μ V
	-100 mV to 100 mV	3.2 μ V

Working Voltage Range

On most MIO X Series devices, the PGIA operates normally by amplifying signals of interest while rejecting common-mode signals under the following three conditions:

- The common-mode voltage (V_{cm}), which is equivalent to subtracting AI $\langle 0..x \rangle$ GND from AI $\langle 0..x \rangle^-$, must be less than ± 10 V. This V_{cm} is a constant for all range selections.
- The signal voltage (V_s), which is equivalent to subtracting AI $\langle 0..x \rangle^+$ from AI $\langle 0..x \rangle^-$, must be less than or equal to the range selection of the given channel. If V_s is greater than the range selected, the signal clips and information are lost.
- The total working voltage of the positive input, which is equivalent to $(V_{cm} + V_s)$, or subtracting AI GND from AI $\langle 0..x \rangle^+$, must be less than ± 11 V.

If any of these conditions are exceeded, the input voltage is clamped until the fault condition is removed.

Analog Input Ground-Reference Settings

MIO X Series devices support the following analog input ground-reference settings:

- **Differential mode**—In DIFF mode, the MIO X Series device measures the difference in voltage between two AI signals.
- **Referenced single-ended mode**—In RSE mode, the MIO X Series device measures the voltage of an AI signal relative to AI GND.
- **Non-referenced single-ended mode**—In NRSE mode, the MIO X Series device measures the voltage of an AI signal relative to one of the AI SENSE inputs specific for that channel.

The AI ground-reference setting determines how you should connect your AI signals to the MIO X Series device. Refer to the [Connecting Analog Input Signals](#) section for more information.

Ground-reference settings are programmed on a per-channel basis. For example, you might configure the device to scan 12 channels—four differentially-configured channels and eight single-ended channels.

MIO X Series devices implement the different analog input ground-reference settings by routing different signals to the NI-PGIA. The NI-PGIA is a differential amplifier. That is, the NI-PGIA amplifies (or attenuates) the difference in voltage between its two inputs. The NI-PGIA drives the ADC with this amplified voltage. The amount of amplification (the gain), is determined by the analog input range, as shown in Figure 4-2.

Figure 4-2. MIO X Series Device NI-PGIA

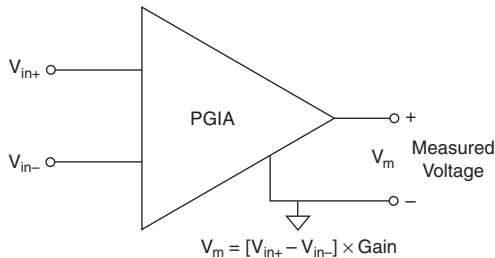

Table 4-2 shows how signals are routed to the NI-PGIA on MIO X Series devices.

Table 4-2. Signals Routed to the NI-PGIA on MIO X Series Devices

AI Ground-Reference Settings	Signals Routed to the Positive Input of the NI-PGIA (Vin+)	Signals Routed to the Negative Input of the NI-PGIA (Vin-)
RSE	AI <0..207>	AI GND
NRSE	AI <0..15>	AI SENSE
	AI <16..79>	AI SENSE 2
	AI <80..143>	AI SENSE 3
	AI <144..207>	AI SENSE 4
DIFF	AI <0..7>	AI <8..15>
	AI <16..23>	AI <24..31>
	AI <32..39>	AI <40..47>
	AI <48..55>	AI <56..63>
	AI <64..71>	AI <72..79>
	AI <80..87>	AI <88..95>
	AI <96..103>	AI <104..111>
	AI <112..119>	AI <120..127>
	AI <128..135>	AI <136..143>
	AI <144..151>	AI <152..159>
	AI <160..167>	AI <168..175>
	AI <176..183>	AI <184..191>
AI <192..199>	AI <200..207>	

For differential measurements, AI 0 and AI 8 are the positive and negative inputs of differential analog input channel 0. For a complete list of signal pairs that form differential input channels, refer to the *I/O Connector Signal Descriptions* section of Chapter 3, *Connector and LED Information*.



Caution The maximum input voltages rating of AI signals with respect to ground (and for signal pairs in differential mode with respect to each other) are listed in the device specifications. Exceeding the maximum input voltage of AI signals distorts the measurement results. Exceeding the maximum input voltage rating can also damage the device and the computer. NI is *not* liable for any damage resulting from such signal connections.

AI ground-reference setting is sometimes referred to as AI terminal configuration.

Configuring AI Ground-Reference Settings in Software

You can program channels on an MIO X Series device to acquire with different ground references.

To enable multimode scanning in LabVIEW, use `NI-DAQmx Create Virtual Channel.vi` of the NI-DAQmx API. You must use a new VI for each channel or group of channels configured in a different input mode. In Figure 4-3, channel 0 is configured in differential mode, and channel 1 is configured in RSE mode.

Figure 4-3. Enabling Multimode Scanning in LabVIEW

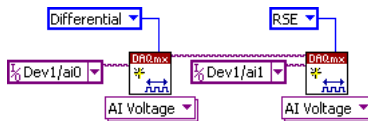

To configure the input mode of your voltage measurement using the DAQ Assistant, use the **Terminal Configuration** drop-down list. Refer to the *DAQ Assistant Help* for more information about the DAQ Assistant.

To configure the input mode of your voltage measurement using the NI-DAQmx C API, set the `terminalConfig` property. Refer to the *NI-DAQmx C Reference Help* for more information.

Multichannel Scanning Considerations

MIO X Series devices can scan multiple channels at high rates and digitize the signals accurately. However, you should consider several issues when designing your measurement system to ensure the high accuracy of your measurements.

In multichannel scanning applications, accuracy is affected by settling time. When your MIO X Series device switches from one AI channel to another AI channel, the device configures the NI-PGIA with the input range of the new channel. The NI-PGIA then amplifies the input signal with the gain for the new input range. Settling time refers to the time it takes the NI-PGIA to amplify the input signal to the desired accuracy before it is sampled by the ADC. To determine your device settling time, refer to the device specifications.

MIO X Series devices are designed to have fast settling times. However, several factors can increase the settling time which decreases the accuracy of your measurements. To ensure fast settling times, you should do the following (in order of importance):

1. **Use Low Impedance Sources**—To ensure fast settling times, your signal sources should have an impedance of <1 k Ω . Large source impedances increase the settling time of the NI-PGIA, and so decrease the accuracy at fast scanning rates.

Settling times increase when scanning high-impedance signals due to a phenomenon called charge injection. Multiplexers contain switches, usually made of switched capacitors. When one of the channels, for example channel 0, is selected in a multiplexer, those capacitors accumulate charge. When the next channel, for example channel 1, is selected, the accumulated charge leaks backward through channel 1. If the output impedance of the source connected to channel 1 is high enough, the resulting reading of channel 1 can be partially affected by the voltage on channel 0. This effect is referred to as ghosting.

If your source impedance is high, you can decrease the scan rate to allow the NI-PGIA more time to settle. Another option is to use a voltage follower circuit external to your DAQ device to decrease the impedance seen by the DAQ device. Refer to the document, *Eliminate Ghosting on Adjacent Input Channels by Decreasing Source Impedance*, by going to ni.com/info and entering the Info Code `rdbbis`.

2. **Use Short High-Quality Cabling**—Using short high-quality cables can minimize several effects that degrade accuracy including crosstalk, transmission line effects, and noise. The capacitance of the cable can also increase the settling time.

National Instruments recommends using individually shielded, twisted-pair wires that are 2 m or less to connect AI signals to the device. Refer to the [Connecting Analog Input Signals](#) section for more information.

3. **Carefully Choose the Channel Scanning Order**

- **Avoid Switching from a Large to a Small Input Range**—Switching from a channel with a large input range to a channel with a small input range can greatly increase the settling time.

Suppose a 4 V signal is connected to channel 0 and a 1 mV signal is connected to channel 1. The input range for channel 0 is -10 V to 10 V and the input range of channel 1 is -200 mV to 200 mV.

When the multiplexer switches from channel 0 to channel 1, the input to the NI-PGIA switches from 4 V to 1 mV. The approximately 4 V step from 4 V to 1 mV is 1,000% of the new full-scale range. For a 16-bit device to settle within 0.0015% (15 ppm or 1 LSB) of the ± 200 mV full-scale range on channel 1, the input circuitry must settle to within 0.000031% (0.31 ppm or 1/50 LSB) of the ± 10 V range. Some devices can take many microseconds for the circuitry to settle this much.

To avoid this effect, you should arrange your channel scanning order so that transitions from large to small input ranges are infrequent.

In general, you do not need this extra settling time when the NI-PGIA is switching from a small input range to a larger input range.

- **Insert Grounded Channel between Signal Channels**—Another technique to improve settling time is to connect an input channel to ground. Then insert this channel in the scan list between two of your signal channels. The input range of the grounded channel should match the input range of the signal after the grounded channel in the scan list.

Consider again the example above where a 4 V signal is connected to channel 0 and a 1 mV signal is connected to channel 1. Suppose the input range for channel 0 is -10 V to 10 V and the input range of channel 1 is -200 mV to 200 mV.

You can connect channel 2 to AI GND (or you can use the internal ground; refer to *Internal Channels* in the *NI-DAQmx Help*). Set the input range of channel 2 to -200 mV to 200 mV to match channel 1. Then scan channels in the order: 0, 2, 1.

Inserting a grounded channel between signal channels improves settling time because the NI-PGIA adjusts to the new input range setting faster when the input is grounded.

- **Minimize Voltage Step between Adjacent Channels**—When scanning between channels that have the same input range, the settling time increases with the voltage step between the channels. If you know the expected input range of your signals, you can group signals with similar expected ranges together in your scan list.

For example, suppose all channels in a system use a -5 V to 5 V input range. The signals on channels 0, 2, and 4 vary between 4.3 V and 5 V. The signals on channels 1, 3, and 5 vary between -4 V and 0 V. Scanning channels in the order 0, 2, 4, 1, 3, 5 produces more accurate results than scanning channels in the order 0, 1, 2, 3, 4, 5.

4. **Avoid Scanning Faster Than Necessary**—Designing your system to scan at slower speeds gives the NI-PGIA more time to settle to a more accurate level. Here are two examples to consider:

- **Example 1**—Averaging many AI samples can increase the accuracy of the reading by decreasing noise effects. In general, the more points you average, the more accurate the final result. However, you may choose to decrease the number of points you average and slow down the scanning rate.

Suppose you want to sample 10 channels over a period of 20 ms and average the results. You could acquire 500 points from each channel at a scan rate of 250 kS/s. Another method would be to acquire 1,000 points from each channel at a scan rate of 500 kS/s. Both methods take the same amount of time. Doubling the number of samples averaged (from 500 to 1,000) decreases the effect of noise by a factor of 1.4 (the square root of 2). However, doubling the number of samples (in this example) decreases the time the NI-PGIA has to settle from 4 μ s to 2 μ s. In some cases, the slower scan rate system returns more accurate results.

- **Example 2**—If the time relationship between channels is not critical, you can sample from the same channel multiple times and scan less frequently. For example, suppose an application requires averaging 100 points from channel 0 and averaging 100 points from channel 1. You could alternate reading between channels—that is, read one point from channel 0, then one point from channel 1, and so on. You also could read all 100 points from channel 0 then read 100 points from channel 1. The second method switches between channels much less often and is affected much less by settling time.

Analog Input Data Acquisition Methods

When performing analog input measurements, you either can perform software-timed or hardware-timed acquisitions.

Software-Timed Acquisitions

With a software-timed acquisition, software controls the rate of the acquisition. Software sends a separate command to the hardware to initiate each ADC conversion. In NI-DAQmx, software-timed acquisitions are referred to as having on-demand timing. Software-timed acquisitions are also referred to as immediate or static acquisitions and are typically used for reading a single sample of data.

Hardware-Timed Acquisitions

With hardware-timed acquisitions, a digital hardware signal (AI Sample Clock) controls the rate of the acquisition. This signal can be generated internally on your device or provided externally.

Hardware-timed acquisitions have several advantages over software-timed acquisitions:

- The time between samples can be much shorter.
- The timing between samples is deterministic.
- Hardware-timed acquisitions can use hardware triggering.

Hardware-timed operations can be buffered or hardware-timed single point (HWTSP). A buffer is a temporary storage in computer memory for to-be-transferred samples.

- **Buffered**—In a buffered acquisition, data is moved from the DAQ device's onboard FIFO memory to a PC buffer using DMA before it is transferred to application memory. Buffered acquisitions typically allow for much faster transfer rates than HWTSP acquisitions because data is moved in large blocks, rather than one point at a time.

One property of buffered I/O operations is the sample mode. The sample mode can be either finite or continuous:

- Finite sample mode acquisition refers to the acquisition of a specific, predetermined number of data samples. Once the specified number of samples has been read in, the acquisition stops. If you use a reference trigger, you must use finite sample mode.
- Continuous acquisition refers to the acquisition of an unspecified number of samples. Instead of acquiring a set number of data samples and stopping, a continuous acquisition continues until you stop the operation. Continuous acquisition is also referred to as double-buffered or circular-buffered acquisition.

If data cannot be transferred across the bus fast enough, the FIFO becomes full. New acquisitions overwrite data in the FIFO before it can be transferred to host memory, which causes the device to generate an error. With continuous operations, if the user program does not read data out of the PC buffer fast enough to keep up with the data transfer, the buffer could reach an overflow condition, causing an error to be generated.

- **Hardware-timed single point (HWTSP)**—Typically, HWTSP operations are used to read single samples at known time intervals. While buffered operations are optimized for high throughput, HWTSP operations are optimized for low latency and low jitter. In addition, HWTSP can notify software if it falls behind hardware. These features make HWTSP ideal for real time control applications. HWTSP operations, in conjunction with the wait for next sample clock function, provide tight synchronization between the software layer and the hardware layer. Refer to the *NI-DAQmx Hardware-Timed Single Point Lateness Checking* document, for more information. To access this document, go to ni.com/info and enter the Info Code `daqhwtsp`.



Note (NI USB-634x/635x/636x Devices) USB X Series devices do not support hardware-timed single point (HWTSP) operations.

Analog Input Triggering

Analog input supports three different triggering actions:

- Start trigger
- Reference trigger
- Pause trigger

Refer to the [AI Start Trigger Signal](#), [AI Reference Trigger Signal](#), and [AI Pause Trigger Signal](#) sections for information about these triggers.

An analog or digital trigger can initiate these actions. All MIO X Series devices support digital triggering, but some do not support analog triggering. To find your device triggering options, refer to the device specifications.

Connecting Analog Input Signals

Table 4-3 summarizes the recommended input configuration for both types of signal sources.

Table 4-3. MIO X Series Analog Input Configuration

AI Ground-Reference Setting [†]	Floating Signal Sources (Not Connected to Building Ground)	Ground-Referenced Signal Sources [†]
	Examples: <ul style="list-style-type: none"> • Ungrounded thermocouples • Signal conditioning with isolated outputs • Battery devices 	Example: <ul style="list-style-type: none"> • Plug-in instruments with non-isolated outputs
Differential		
Non-Referenced Single-Ended (NRSE)		
Referenced Single-Ended (RSE)		<p style="text-align: center;">NOT RECOMMENDED</p> <p>Ground-loop potential ($V_A - V_B$) are added to measured signal.</p>
<p>* Refer to the Analog Input Ground-Reference Settings section for descriptions of the RSE, NRSE, and DIFF modes and software considerations.</p> <p>† Refer to the Connecting Ground-Referenced Signal Sources section for more information.</p>		

Connecting Floating Signal Sources

What Are Floating Signal Sources?

A floating signal source is not connected to the building ground system, but has an isolated ground-reference point. Some examples of floating signal sources are outputs of transformers, thermocouples, battery-powered devices, optical isolators, and isolation amplifiers. An instrument or device that has an isolated output is a floating signal source.

When to Use Differential Connections with Floating Signal Sources

Use DIFF input connections for any channel that meets any of the following conditions:

- The input signal is low level (less than 1 V).
- The leads connecting the signal to the device are greater than 3 m (10 ft).
- The input signal requires a separate ground-reference point or return signal.
- The signal leads travel through noisy environments.
- Two analog input channels, AI+ and AI-, are available for the signal.

DIFF signal connections reduce noise pickup and increase common-mode noise rejection. DIFF signal connections also allow input signals to float within the common-mode limits of the NI-PGIA.

Refer to the *Using Differential Connections for Floating Signal Sources* section for more information about differential connections.

When to Use Non-Referenced Single-Ended (NRSE) Connections with Floating Signal Sources

Only use NRSE input connections if the input signal meets the following conditions:

- The input signal is high-level (greater than 1 V).
- The leads connecting the signal to the device are less than 3 m (10 ft).

DIFF input connections are recommended for greater signal integrity for any input signal that does not meet the preceding conditions.

In the single-ended modes, more electrostatic and magnetic noise couples into the signal connections than in DIFF configurations. The coupling is the result of differences in the signal path. Magnetic coupling is proportional to the area between the two signal conductors. Electrical coupling is a function of how much the electric field differs between the two conductors.

With this type of connection, the NI-PGIA rejects both the common-mode noise in the signal and the ground potential difference between the signal source and the device ground.

Refer to the *Using Non-Referenced Single-Ended (NRSE) Connections for Floating Signal Sources* section for more information about NRSE connections.

When to Use Referenced Single-Ended (RSE) Connections with Floating Signal Sources

Only use RSE input connections if the input signal meets the following conditions:

- The input signal can share a common reference point, AI GND, with other signals that use RSE.
- The input signal is high-level (greater than 1 V).
- The leads connecting the signal to the device are less than 3 m (10 ft).

DIFF input connections are recommended for greater signal integrity for any input signal that does not meet the preceding conditions.

In the single-ended modes, more electrostatic and magnetic noise couples into the signal connections than in DIFF configurations. The coupling is the result of differences in the signal path. Magnetic coupling is proportional to the area between the two signal conductors. Electrical coupling is a function of how much the electric field differs between the two conductors.

With this type of connection, the NI-PGIA rejects both the common-mode noise in the signal and the ground potential difference between the signal source and the device ground.

Refer to the [Using Referenced Single-Ended \(RSE\) Connections for Floating Signal Sources](#) section for more information about RSE connections.

Using Differential Connections for Floating Signal Sources

It is important to connect the negative lead of a floating source to AI GND (either directly or through a bias resistor). Otherwise, the source may float out of the maximum working voltage range of the NI-PGIA and the DAQ device returns erroneous data.

The easiest way to reference the source to AI GND is to connect the positive side of the signal to AI+ and connect the negative side of the signal to AI GND as well as to AI- without using resistors. This connection works well for DC-coupled sources with low source impedance (less than 100 Ω).



Note (NI USB-6341/6343/6346/6361/6363 BNC Devices) To measure a floating signal source on X Series USB BNC devices, move the switch under the BNC connector to the FS position.

Figure 4-4. Differential Connections for Floating Signal Sources without Bias Resistors

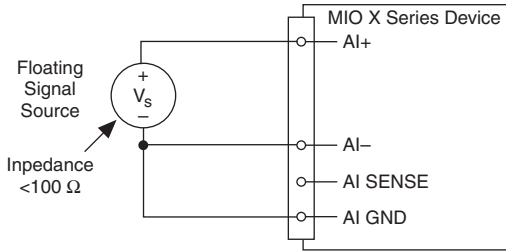

However, for larger source impedances, this connection leaves the DIFF signal path significantly off balance. Noise that couples electrostatically onto the positive line does not couple onto the negative line because it is connected to ground. This noise appears as a differential mode signal instead of a common-mode signal, and thus appears in your data. In this case, instead of directly connecting the negative line to AI GND, connect the negative line to AI GND through a resistor that is about 100 times the equivalent source impedance. The resistor puts the signal path nearly in balance, so that about the same amount of noise couples onto both connections, yielding better rejection of electrostatically coupled noise. This configuration does not load down the source (other than the very high input impedance of the NI-PGIA).

Figure 4-5. Differential Connections for Floating Signal Sources with Single Bias Resistor

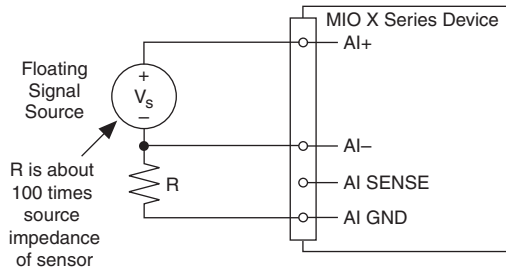

You can fully balance the signal path by connecting another resistor of the same value between the positive input and AI GND, as shown in Figure 4-6. This fully balanced configuration offers slightly better noise rejection, but has the disadvantage of loading the source down with the series combination (sum) of the two resistors. If, for example, the source impedance is 2 k Ω and each of the two resistors is 100 k Ω , the resistors load down the source with 200 k Ω and produce a -1% gain error.

Figure 4-6. Differential Connections for Floating Signal Sources with Balanced Bias Resistors

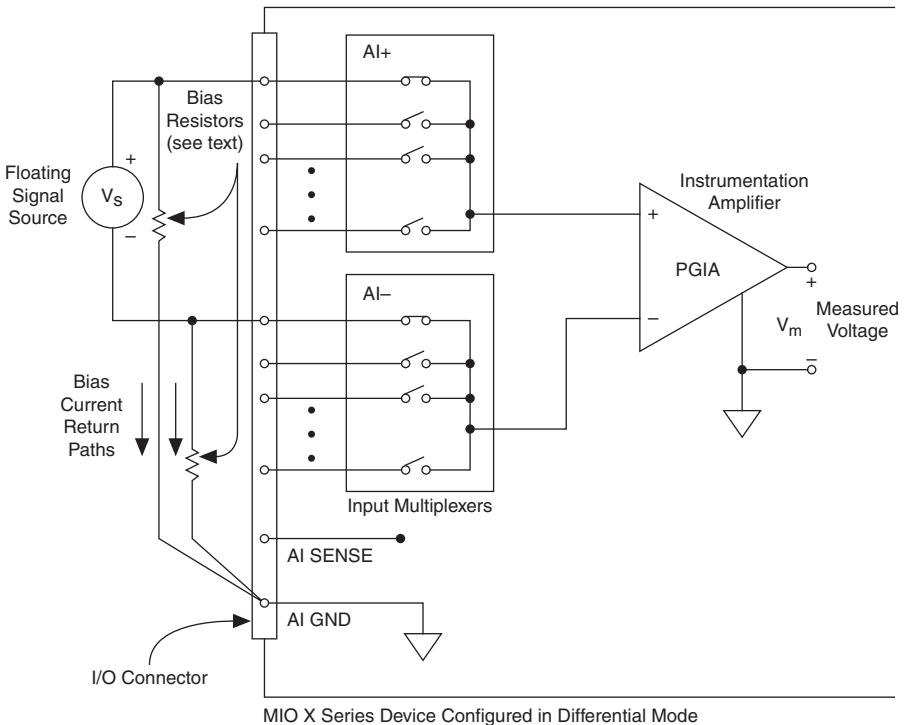

Both inputs of the NI-PGIA require a DC path to ground in order for the NI-PGIA to work. If the source is AC coupled (capacitively coupled), the NI-PGIA needs a resistor between the positive input and AI GND. If the source has low-impedance, choose a resistor that is large enough not to significantly load the source, but small enough not to produce significant input offset voltage as a result of input bias current (typically 100 k Ω to 1 M Ω). In this case, connect the negative input directly to AI GND. If the source has high output impedance, balance the

signal path as previously described using the same value resistor on both the positive and negative inputs; be aware that there is some gain error from loading down the source, as shown in Figure 4-7.

Figure 4-7. Differential Connections for AC Coupled Floating Sources with Balanced Bias Resistors

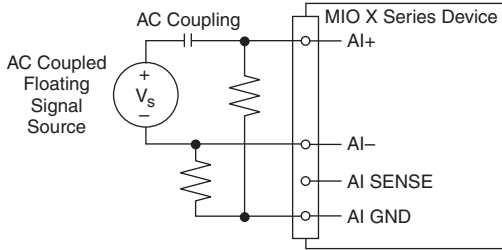

Using Non-Referenced Single-Ended (NRSE) Connections for Floating Signal Sources

It is important to connect the negative lead of a floating signals source to AI GND (either directly or through a resistor). Otherwise the source may float out of the valid input range of the NI-PGIA and the DAQ device returns erroneous data.



Note (NI USB-6341/6343/6346/6361/6363 BNC Devices) To measure a floating signal source on X Series USB BNC devices, move the switch under the BNC connector to the FS position.

Figure 4-8 shows a floating source connected to the DAQ device in NRSE mode.

Figure 4-8. NRSE Connections for Floating Signal Sources

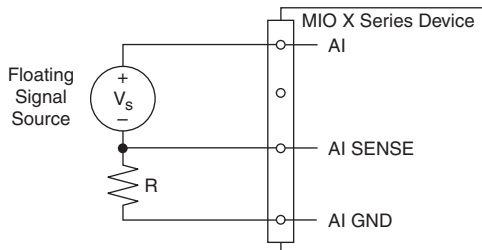

All of the bias resistor configurations discussed in the *Using Differential Connections for Floating Signal Sources* section apply to the NRSE bias resistors as well. Replace AI- with AI SENSE in Figures 4-4, 4-5, 4-6, and 4-7 for configurations with zero to two bias resistors. The noise rejection of NRSE mode is better than RSE mode because the AI SENSE connection is made remotely near the source. However, the noise rejection of NRSE mode is worse than DIFF mode because the AI SENSE connection is shared with all channels rather than being cabled in a twisted pair with the AI+ signal.

Using the DAQ Assistant, you can configure the channels for RSE or NRSE input modes. Refer to the [Configuring AI Ground-Reference Settings in Software](#) section for more information about the DAQ Assistant.

Using Referenced Single-Ended (RSE) Connections for Floating Signal Sources

Figure 4-9 shows how to connect a floating signal source to the MIO X Series device configured for RSE mode.

Figure 4-9. RSE Connections for Floating Signal Sources

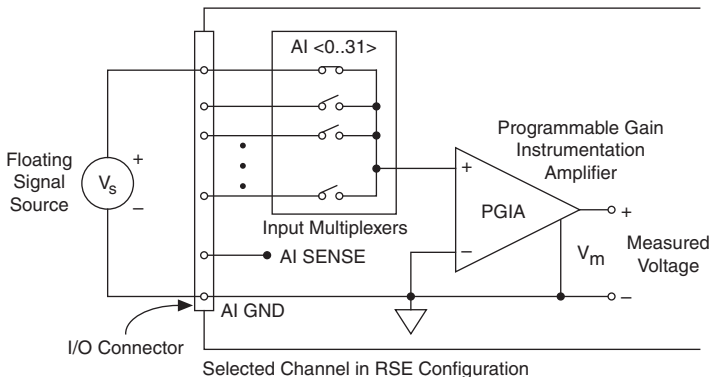

Note (NI USB-6341/6343/6361/6363 BNC Devices) To measure a floating signal source on X Series USB BNC devices, move the switch under the BNC connector to the FS position.

Using the DAQ Assistant, you can configure the channels for RSE or NRSE input modes. Refer to the [Configuring AI Ground-Reference Settings in Software](#) section for more information about the DAQ Assistant.

Connecting Ground-Referenced Signal Sources

What Are Ground-Referenced Signal Sources?

A ground-referenced signal source is a signal source connected to the building system ground. It is already connected to a common ground point with respect to the device, assuming that the computer is plugged into the same power system as the source. Non-isolated outputs of instruments and devices that plug into the building power system fall into this category.

The difference in ground potential between two instruments connected to the same building power system is typically between 1 and 100 mV, but the difference can be much higher if power distribution circuits are improperly connected. If a grounded signal source is incorrectly measured, this difference can appear as measurement error. Follow the connection instructions

for grounded signal sources to eliminate this ground potential difference from the measured signal.

When to Use Differential Connections with Ground-Referenced Signal Sources

Use DIFF input connections for any channel that meets any of the following conditions:

- The input signal is low level (less than 1 V).
- The leads connecting the signal to the device are greater than 3 m (10 ft).
- The input signal requires a separate ground-reference point or return signal.
- The signal leads travel through noisy environments.
- Two analog input channels, AI+ and AI-, are available.

DIFF signal connections reduce noise pickup and increase common-mode noise rejection. DIFF signal connections also allow input signals to float within the common-mode limits of the NI-PGIA.

Refer to the [Using Differential Connections for Ground-Referenced Signal Sources](#) section for more information about differential connections.

When to Use Non-Referenced Single-Ended (NRSE) Connections with Ground-Referenced Signal Sources

Only use NRSE connections if the input signal meets the following conditions:

- The input signal is high-level (greater than 1 V).
- The leads connecting the signal to the device are less than 3 m (10 ft).
- The input signal can share a common reference point with other signals.

DIFF input connections are recommended for greater signal integrity for any input signal that does not meet the preceding conditions.

In the single-ended modes, more electrostatic and magnetic noise couples into the signal connections than in DIFF configurations. The coupling is the result of differences in the signal path. Magnetic coupling is proportional to the area between the two signal conductors. Electrical coupling is a function of how much the electric field differs between the two conductors.

With this type of connection, the NI-PGIA rejects both the common-mode noise in the signal and the ground potential difference between the signal source and the device ground.

Refer to the [Using Non-Referenced Single-Ended \(NRSE\) Connections for Ground-Referenced Signal Sources](#) section for more information about NRSE connections.

When to Use Referenced Single-Ended (RSE) Connections with Ground-Referenced Signal Sources

Do *not* use RSE connections with ground-referenced signal sources. Use NRSE or DIFF connections instead.

As shown in the bottom-rightmost cell of Table 4-3, there can be a potential difference between AI GND and the ground of the sensor. In RSE mode, this ground loop causes measurement errors.

Using Differential Connections for Ground-Referenced Signal Sources

Figure 4-10 shows how to connect a ground-referenced signal source to the MIO X Series device configured in differential mode.

Figure 4-10. Differential Connections for Ground-Referenced Signal Sources

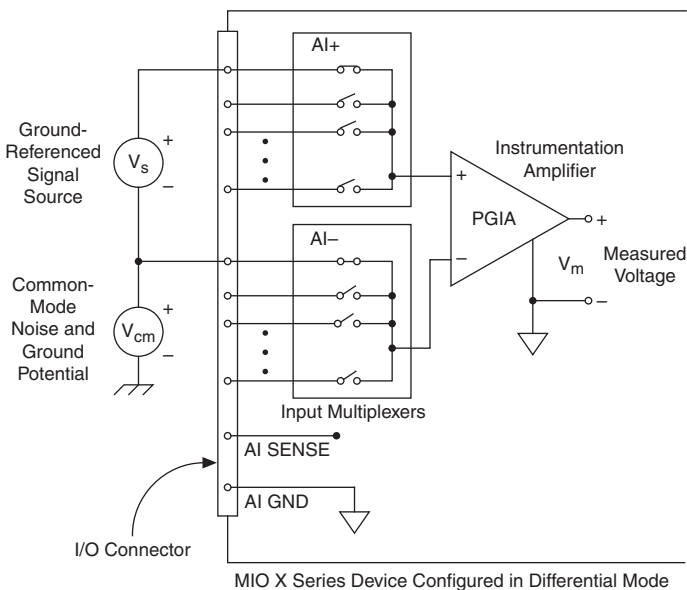

Note (NI USB-6341/6343/6346/6361/6363 BNC Devices) To measure a ground-referenced signal source on X Series USB BNC devices, move the switch under the BNC connector to the GS position.

With this type of connection, the NI-PGIA rejects both the common-mode noise in the signal and the ground potential difference between the signal source and the device ground, shown as V_{cm} in the figure.

AI+ and AI- must both remain within ± 11 V of AI GND.

Using Non-Referenced Single-Ended (NRSE) Connections for Ground-Referenced Signal Sources

Figure 4-11 shows how to connect ground-reference signal sources in NRSE mode.

Figure 4-11. Single-Ended Connections for Ground-Referenced Signal Sources (NRSE Configuration)

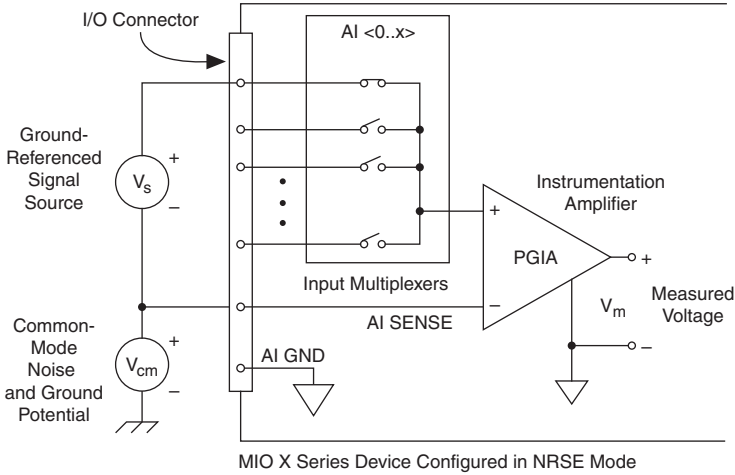

Note (NI USB-6341/6343/6346/6361/6363 BNC Devices) To measure a ground-referenced signal source on X Series USB BNC devices, move the switch under the BNC connector to the GS position.

AI <0..31> and AI SENSE must both remain within ± 11 V of AI GND.

To measure a single-ended, ground-referenced signal source, you must use the NRSE ground-reference setting. Use Table 4-4 to determine how to correctly connect your AI signal.

Table 4-4. AI Signal Connections

Signal	Ground-Reference
AI <0..15>	AI SENSE
AI <16..79>	AI SENSE 2
AI <80..143>	AI SENSE 3
AI <144..207>	AI SENSE 4

AI SENSE is internally connected to the negative input of the NI-PGIA. Therefore, the ground point of the signal connects to the negative input of the NI-PGIA.

Any potential difference between the device ground and the signal ground appears as a common-mode signal at both the positive and negative inputs of the NI-PGIA, and this difference is rejected by the amplifier. If the input circuitry of a device were referenced to ground, as it is in the RSE ground-reference setting, this difference in ground potentials would appear as an error in the measured voltage.

Using the DAQ Assistant, you can configure the channels for RSE or NRSE input modes. Refer to the [Configuring AI Ground-Reference Settings in Software](#) section for more information about the DAQ Assistant.

Field Wiring Considerations

Environmental noise can seriously affect the measurement accuracy of the device if you do not take proper care when running signal wires between signal sources and the device. The following recommendations apply mainly to AI signal routing to the device, although they also apply to signal routing in general.

Minimize noise pickup and maximize measurement accuracy by taking the following precautions:

- Use differential analog input connections to reject common-mode noise.
- Use individually shielded, twisted-pair wires to connect AI signals to the device. With this type of wire, the signals attached to the positive and negative input channels are twisted together and then covered with a shield. You then connect this shield only at one point to the signal source ground. This kind of connection is required for signals traveling through areas with large magnetic fields or high electromagnetic interference.

Refer to the *Field Wiring and Noise Considerations for Analog Signals* document, for more information. To access this document, go to ni.com/info and enter the Info Code `rdfwn3`.

Analog Input Timing Signals

In order to provide all of the timing functionality described throughout this section, MIO X Series devices have a flexible timing engine. Figure 4-12 summarizes all of the timing options provided by the analog input timing engine. Also refer to the [Clock Routing](#) section of Chapter 9, *Digital Routing and Clock Generation*.

Figure 4-12. Analog Input Timing Options

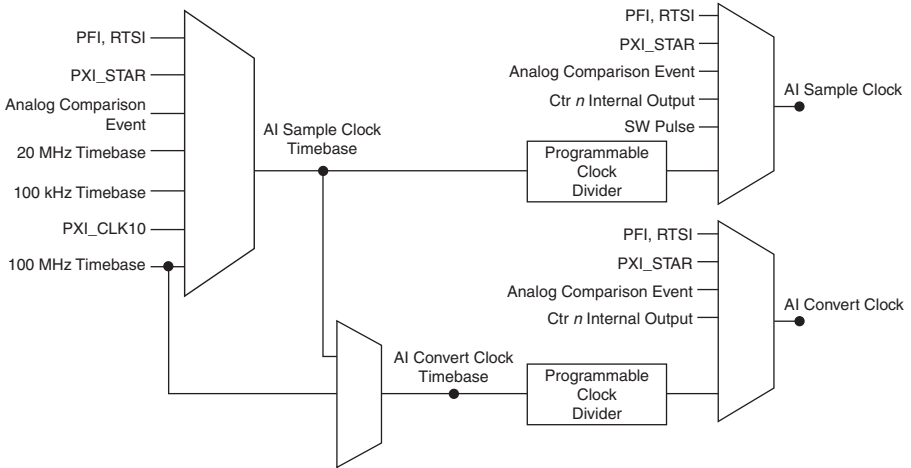

MIO X Series devices use AI Sample Clock (ai/SampleClock) and AI Convert Clock (ai/ConvertClock) to perform interval sampling. As Figure 4-13 shows, AI Sample Clock controls the sample period, which is determined by the following equation:

$$1/\text{Sample Period} = \text{Sample Rate}$$

Figure 4-13. MIO X Series Interval Sampling

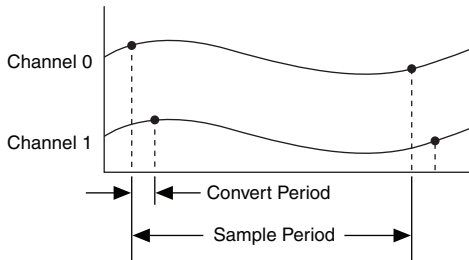

AI Convert Clock controls the Convert Period, which is determined by the following equation:

$$1/\text{Convert Period} = \text{Convert Rate}$$

Posttriggered data acquisition allows you to view only data that is acquired after a trigger event is received. A typical posttriggered DAQ sequence is shown in Figure 4-14. The sample counter is loaded with the specified number of posttrigger samples, in this example, five. The value decrements with each pulse on AI Sample Clock, until all desired samples have been acquired.

Figure 4-14. Posttriggered Data Acquisition Example

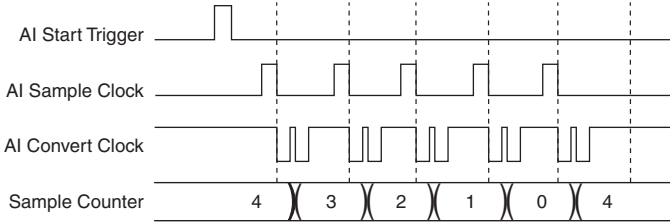

Pretriggered data acquisition allows you to view data that is acquired before the trigger of interest, in addition to data acquired after the trigger. Figure 4-15 shows a typical pretriggered DAQ sequence. AI Start Trigger (ai/StartTrigger) can be either a hardware or software signal. If AI Start Trigger is set up to be a software start trigger, an output pulse appears on the ai/StartTrigger line when the acquisition begins. When the AI Start Trigger pulse occurs, the sample counter is loaded with the number of pretriggered samples, in this example, four. The value decrements with each pulse on AI Sample Clock. The sample counter is then loaded with the number of posttriggered samples, in this example, three.

Figure 4-15. Pretriggered Data Acquisition Example

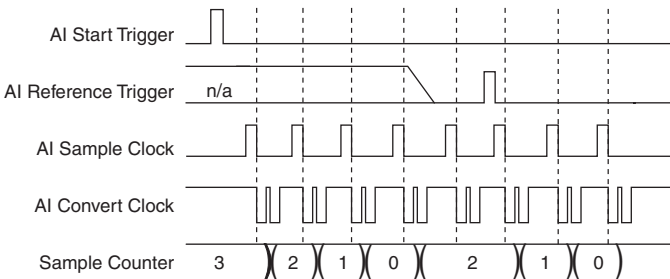

If an AI Reference Trigger (ai/ReferenceTrigger) pulse occurs before the specified number of pretrigger samples are acquired, the trigger pulse is ignored. Otherwise, when the AI Reference Trigger pulse occurs, the sample counter value decrements until the specified number of posttrigger samples have been acquired.

MIO X Series devices feature the following analog input timing signals:

- *AI Sample Clock Signal**
- *AI Sample Clock Timebase Signal*
- *AI Convert Clock Signal**
- *AI Convert Clock Timebase Signal*

- *AI Hold Complete Event Signal*
- *AI Start Trigger Signal**
- *AI Reference Trigger Signal**
- *AI Pause Trigger Signal**

Signals with an * support digital filtering. Refer to the *PFI Filters* section of Chapter 8, *PFI*, for more information.

Aggregate versus Single Channel Sample Rates

MIO X Series devices are characterized with maximum single channel and maximum aggregate sample rates. The maximum single channel rate is the fastest you can acquire data on the device from a single channel and still achieve accurate results. The maximum aggregate sample rate is the fastest you can acquire on multiple channels and still achieve accurate results. For example, NI 6351 devices have a single channel maximum rate of 1.25 MS/s and aggregate maximum sample rate of 1 MS/s so they can sample one channel at 1.25 MS/s or two channels at 500 kS/s per channel, as shown in Table 4-5.

Table 4-5. Analog Input Rates for MIO X Series Devices

MIO X Series Device	Analog Input Rate*	
	Single Channel	Multi-Channel (Aggregate)
NI 6320/6321/6323	250 kS/s	250 kS/s
NI 6341/6343/6345	500 kS/s	500 kS/s
NI 6351/6353/6355	1.25 MS/s	1 MS/s
NI 6361/6363/6365	2 MS/s	1 MS/s
NI 6375	3.846 MS/s	1 MS/s

* On several devices, the single channel rate is higher than the aggregate rate because while the ADC can sample at that rate, the PGIA cannot settle fast enough to meet accuracy specifications.

AI Sample Clock Signal

Use the AI Sample Clock (ai/SampleClock) signal to initiate a set of measurements. Your MIO X Series device samples the AI signals of every channel in the task once for every AI Sample Clock. A measurement acquisition consists of one or more samples.

You can specify an internal or external source for AI Sample Clock. You can also specify whether the measurement sample begins on the rising edge or falling edge of AI Sample Clock.

Using an Internal Source

One of the following internal signals can drive AI Sample Clock:

- Counter n Internal Output
- AI Sample Clock Timebase (divided down)
- A pulse initiated by host software
- Change Detection Event
- Counter n Sample Clock
- AO Sample Clock (ao/SampleClock)
- DI Sample Clock (di/SampleClock)
- DO Sample Clock (do/SampleClock)

A programmable internal counter divides down the sample clock timebase.

Several other internal signals can be routed to AI Sample Clock through internal routes. Refer to *Device Routing in MAX* in the *NI-DAQmx Help* or the *LabVIEW Help* for more information.

Using an External Source

Use one of the following external signals as the source of AI Sample Clock:

- PFI <0..15>
- RTSI <0..7>
- PXI_STAR
- PXIe_DSTAR<A,B>
- Analog Comparison Event (an analog trigger)

Routing AI Sample Clock Signal to an Output Terminal

You can route AI Sample Clock out to any PFI <0..15>, RTSI <0..7>, or PXIe_DSTARC terminal. This pulse is always active high.

All PFI terminals are configured as inputs by default.

Other Timing Requirements

Your DAQ device only acquires data during an acquisition. The device ignores AI Sample Clock when a measurement acquisition is not in progress. During a measurement acquisition, you can cause your DAQ device to ignore AI Sample Clock using the AI Pause Trigger signal.

A counter/timing engine on your device internally generates AI Sample Clock unless you select some external source. AI Start Trigger starts this counter and either software or hardware can stop it once a finite acquisition completes. When using the AI timing engine, you can also specify a configurable delay from AI Start Trigger to the first AI Sample Clock pulse. By default, this delay is set to four ticks of the AI Sample Clock Timebase signal.

When using an externally generated AI Sample Clock, you must ensure the clock signal is consistent with respect to the timing requirements of AI Convert Clock. Failure to do so may result in a scan overrun and will cause an error. Refer to the *AI Convert Clock Signal* section for more information about the timing requirements between AI Convert Clock and AI Sample Clock.

Figure 4-16 shows the relationship of AI Sample Clock to AI Start Trigger.

Figure 4-16. AI Sample Clock and AI Start Trigger

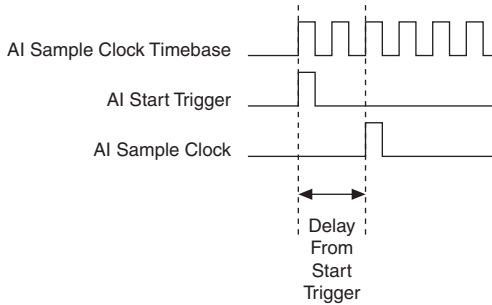

AI Sample Clock Timebase Signal

You can route any of the following signals to be the AI Sample Clock Timebase (ai/SampleClockTimebase) signal:

- 100 MHz Timebase (default)
- 20 MHz Timebase
- 100 kHz Timebase
- PXI_CLK10
- RTSI <0..7>
- PFI <0..15>
- PXI_STAR
- PXIe_DSTAR<A,B>
- Analog Comparison Event (an analog trigger)

AI Sample Clock Timebase is not available as an output on the I/O connector. AI Sample Clock Timebase is divided down to provide one of the possible sources for AI Sample Clock. You can configure the polarity selection for AI Sample Clock Timebase as either rising or falling edge, except on 100 MHz Timebase or 20 MHz Timebase.

AI Convert Clock Signal

Use the AI Convert Clock (ai/ConvertClock) signal to initiate a single A/D conversion on a single channel. A sample (controlled by the AI Sample Clock) consists of one or more conversions.

You can specify either an internal or external signal as the source of AI Convert Clock. You can also specify whether the measurement sample begins on the rising edge or falling edge of AI Convert Clock.

With NI-DAQmx, the driver chooses the fastest conversion rate possible based on the speed of the A/D converter and adds 10 μ s of padding between each channel to allow for adequate settling time. This scheme enables the channels to approximate simultaneous sampling and still allow for adequate settling time. If the AI Sample Clock rate is too fast to allow for this 10 μ s of padding, NI-DAQmx chooses the conversion rate so that the AI Convert Clock pulses are evenly spaced throughout the sample.

To explicitly specify the conversion rate, use **AI Convert Clock Rate DAQmx Timing** property node or function.



Caution Setting the conversion rate higher than the maximum rate specified for your device will result in errors.

Using an Internal Source

One of the following internal signals can drive AI Convert Clock:

- AI Convert Clock Timebase (divided down)
- Counter n Internal Output
- Change Detection Event
- Counter n Sample Clock
- AO Sample Clock (ao/SampleClock)
- DI Sample Clock (di/SampleClock)
- DO Sample Clock (do/SampleClock)

A programmable internal counter divides down the AI Convert Clock Timebase to generate AI Convert Clock. The counter is started by AI Sample Clock and continues to count down to zero, produces an AI Convert Clock, reloads itself, and repeats the process until the sample is finished. It then reloads itself in preparation for the next AI Sample Clock pulse.

Several other internal signals can be routed to AI Convert Clock through internal routes. Refer to *Device Routing in MAX* in the *NI-DAQmx Help* or the *LabVIEW Help* for more information.

Using an External Source

Use one of the following external signals as the source of AI Convert Clock:

- PFI <0..15>
- RTSI <0..7>
- PXI_STAR
- PXIe_DSTAR<A,B>
- Analog Comparison Event (an analog trigger)

Routing AI Convert Clock Signal to an Output Terminal

You can route AI Convert Clock (as an active low signal) out to any PFI <0..15>, RTSI <0..7>, or PXIe_DSTAR terminal.

All PFI terminals are configured as inputs by default.

Using a Delay from Sample Clock to Convert Clock

When using the AI timing engine to generate your Convert Clock, you can also specify a configurable delay from AI Sample Clock to the first AI Convert Clock pulse within the sample. By default, this delay is three ticks of AI Convert Clock Timebase.

Figure 4-17 shows the relationship of AI Sample Clock to AI Convert Clock.

Figure 4-17. AI Sample Clock and AI Convert Clock

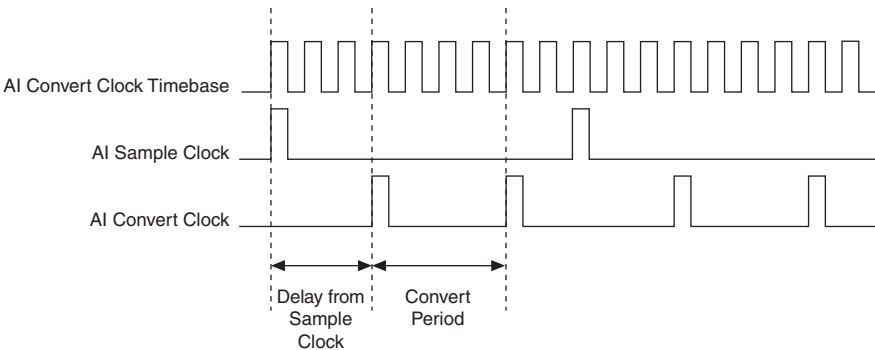

Other Timing Requirements

The sample and conversion level timing of MIO X Series devices work such that some clock signals are gated off unless the proper timing requirements are met. For example, the device ignores both AI Sample Clock and AI Convert Clock until it receives a valid AI Start Trigger signal. Similarly, the device ignores all AI Convert Clock pulses until it recognizes an AI Sample Clock pulse. Once the device receives the correct number of AI Convert Clock pulses, it ignores subsequent AI Convert Clock pulses until it receives another AI Sample Clock. However, after

the device recognizes an AI Sample Clock pulse, it causes an error if it receives an AI Sample Clock pulse before the correct number of AI Convert Clock pulses are received.

Figures 4-18, 4-19, 4-20, and 4-21 show timing sequences for a four-channel acquisition (using AI channels 0, 1, 2, and 3) and demonstrate proper and improper sequencing of AI Sample Clock and AI Convert Clock.

Figure 4-18. Scan Overrun Condition; AI Sample Clock Too Fast For Convert Clock Causes an Error

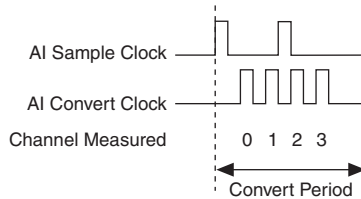

Figure 4-19. AI Convert Clock Too Fast For AI Sample Clock; AI Convert Clock Pulses Are Ignored

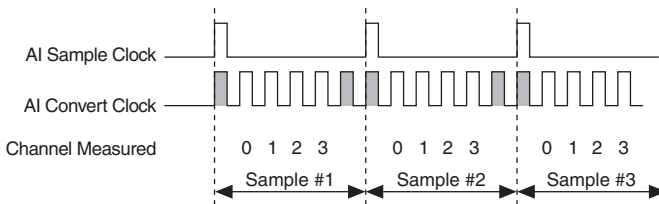

Figure 4-20. AI Sample Clock and AI Convert Clock Improperly Matched; Leads to Aperiodic Sampling

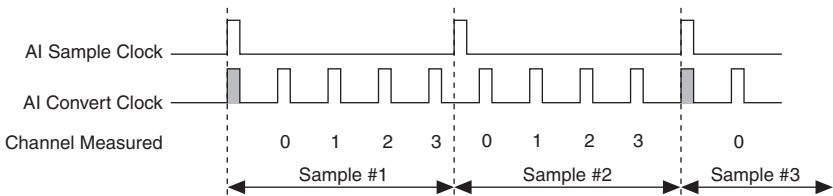
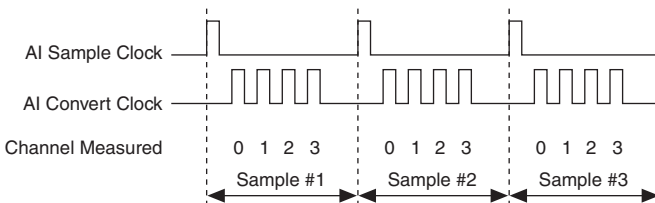

Figure 4-21. AI Sample Clock and AI Convert Clock Properly Matched



AI Convert Clock Timebase Signal

The AI Convert Clock Timebase (ai/ConvertClockTimebase) signal is divided down to provide one of the possible sources for AI Convert Clock. Use one of the following signals as the source of AI Convert Clock Timebase:

- AI Sample Clock Timebase
- 100 MHz Timebase

AI Convert Clock Timebase is not available as an output on the I/O connector.

AI Hold Complete Event Signal

The AI Hold Complete Event (ai/HoldCompleteEvent) signal generates a pulse after each A/D conversion begins. You can route AI Hold Complete Event out to any PFI <0..15>, RTSI <0..7>, or PXIe_DSTARC terminal.

The polarity of AI Hold Complete Event is software-selectable, but is typically configured so that a low-to-high leading edge can clock external AI multiplexers indicating when the input signal has been sampled and can be removed.

AI Start Trigger Signal

Use the AI Start Trigger (ai/StartTrigger) signal to begin a measurement acquisition. A measurement acquisition consists of one or more samples. If you do not use triggers, begin a measurement with a software command. Once the acquisition begins, configure the acquisition to stop:

- When a certain number of points are sampled (in finite mode)
- After a hardware reference trigger (in finite mode)
- With a software command (in continuous mode)

An acquisition that uses a start trigger (but not a reference trigger) is sometimes referred to as a posttriggered acquisition.

Retriggerable Analog Input

The AI Start Trigger is also configurable as retriggerable. The timing engine generates the sample and convert clocks for the configured acquisition in response to each pulse on an AI Start Trigger signal.

The timing engine ignores the AI Start Trigger signal while the clock generation is in progress. After the clock generation is finished, the counter waits for another Start Trigger to begin another clock generation. Figure 4-22 shows a retriggerable analog input with three AI channels and four samples per trigger.

Figure 4-22. Retriggerable Analog Input

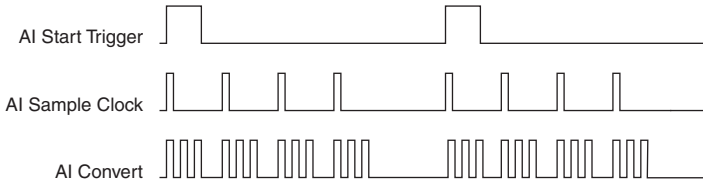

Note Waveform information from LabVIEW does not reflect the delay between triggers. They are treated as a continuous acquisition with constant t_0 and dt information.

Reference triggers are not retriggerable.

Using a Digital Source

To use AI Start Trigger with a digital source, specify a source and an edge. The source can be any of the following signals:

- PFI <0..15>
- RTSI <0..7>
- Counter n Internal Output
- PXI_STAR
- PXIe_DSTAR<A,B>
- Change Detection Event
- AO Start Trigger (ao/StartTrigger)
- DI Start Trigger (di/StartTrigger)
- DO Start Trigger (do/StartTrigger)

The source can also be one of several other internal signals on your DAQ device. Refer to *Device Routing in MAX* in the *NI-DAQmx Help* or the *LabVIEW Help* for more information.

You can also specify whether the measurement acquisition begins on the rising edge or falling edge of AI Start Trigger.

Using an Analog Source

When you use an analog trigger source, the acquisition begins on the first rising edge of the Analog Comparison Event signal.

Routing AI Start Trigger to an Output Terminal

You can route AI Start Trigger out to any PFI <0..15>, RTSI <0..7>, or PXIe_DSTARC terminal. The output is an active high pulse. All PFI terminals are configured as inputs by default.

The device also uses AI Start Trigger to initiate pretriggered DAQ operations. In most pretriggered applications, a software trigger generates AI Start Trigger. Refer to the *AI Reference Trigger Signal* section for a complete description of the use of AI Start Trigger and AI Reference Trigger in a pretriggered DAQ operation.

AI Reference Trigger Signal

Use AI Reference Trigger (ai/ReferenceTrigger) signal to stop a measurement acquisition. To use a reference trigger, specify a buffer of finite size and a number of pretrigger samples (samples that occur before the reference trigger). The number of posttrigger samples (samples that occur after the reference trigger) desired is the buffer size minus the number of pretrigger samples.

Once the acquisition begins, the DAQ device writes samples to the buffer. After the DAQ device captures the specified number of pretrigger samples, the DAQ device begins to look for the reference trigger condition. If the reference trigger condition occurs before the DAQ device captures the specified number of pretrigger samples, the DAQ device ignores the condition.

If the buffer becomes full, the DAQ device continuously discards the oldest samples in the buffer to make space for the next sample. This data can be accessed (with some limitations) before the DAQ device discards it. Refer to the document, *Can a Pretriggered Analog Acquisition be Continuous?*, for more information. To access this document, go to ni.com/info and enter the Info Code `rdcanq`.

When the reference trigger occurs, the DAQ device continues to write samples to the buffer until the buffer contains the number of posttrigger samples desired. Figure 4-23 shows the final buffer.

Figure 4-23. Reference Trigger Final Buffer

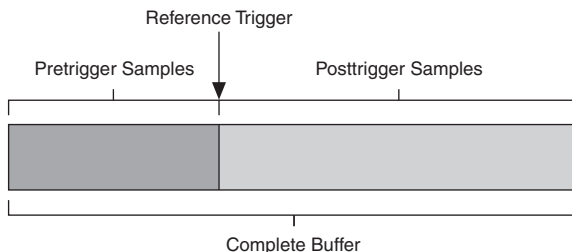

Using a Digital Source

To use AI Reference Trigger with a digital source, specify a source and an edge. The source can be any of the following signals:

- PFI <0..15>
- RTSI <0..7>
- PXI_STAR
- PXIe_DSTAR<A,B>
- Change Detection Event
- Counter *n* Internal Output
- DI Reference Trigger (di/ReferenceTrigger)
- DO Start Trigger (do/StartTrigger)
- AO Start Trigger (ao/StartTrigger)

The source can also be one of several internal signals on your DAQ device. Refer to *Device Routing in MAX* in the *NI-DAQmx Help* or the *LabVIEW Help* for more information.

You can also specify whether the measurement acquisition stops on the rising edge or falling edge of AI Reference Trigger.

Using an Analog Source

When you use an analog trigger source, the acquisition stops on the first rising edge of the Analog Comparison Event signal.

Routing AI Reference Trigger Signal to an Output Terminal

You can route AI Reference Trigger out to any PFI <0..15>, RTSI <0..7>, PXI_Trig <0..7>, or PXIe_DSTAR terminal.

All PFI terminals are configured as inputs by default.

AI Pause Trigger Signal

Use the AI Pause Trigger (`ai/PauseTrigger`) signal to pause and resume a measurement acquisition. The internal sample clock pauses while the external trigger signal is active and resumes when the signal is inactive. You can program the active level of the pause trigger to be high or low, as shown in Figure 4-24. In the figure, T represents the period, and A represents the unknown time between the clock pulse and the posttrigger.

Figure 4-24. Halt (Internal Clock) and Free Running (External Clock)

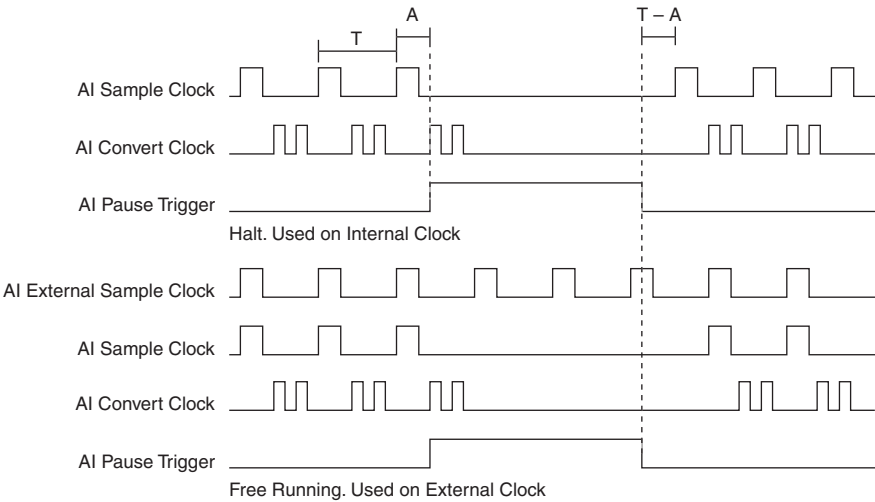

Using a Digital Source

To use AI Pause Trigger, specify a source and a polarity. The source can be any of the following signals:

- PFI <0..15>
- RTSI <0..7>
- PXI_STAR
- PXIe_DSTAR<A,B>
- Counter n Internal Output
- Counter n Gate
- AO Pause Trigger (`ao/PauseTrigger`)
- DO Pause Trigger (`do/PauseTrigger`)
- DI Pause Trigger (`di/PauseTrigger`)

The source can also be one of several other internal signals on your DAQ device. Refer to *Device Routing in MAX* in the *NI-DAQmx Help* or the *LabVIEW Help* for more information.

Using an Analog Source

When you use an analog trigger source, the internal sample clock pauses when the Analog Comparison Event signal is low and resumes when the signal goes high (or vice versa).

Routing AI Pause Trigger Signal to an Output Terminal

You can route AI Pause Trigger out to any PFI <0..15>, RTSI <0..7>, PXI_STAR, or PXIe_DSTARC terminal.



Note Pause triggers are only sensitive to the level of the source, not the edge.

Getting Started with AI Applications in Software

You can use the MIO X Series device in the following analog input applications:

- Single-point analog input (on demand)
- Finite analog input
- Continuous analog input
- Hardware-timed single point

You can perform these applications through DMA or programmed I/O data transfer mechanisms. Some of the applications also use start, reference, and pause triggers.



Note For more information about programming analog input applications and triggers in software, refer to the *NI-DAQmx Help* or the *LabVIEW Help*.

MIO X Series devices use the NI-DAQmx driver. NI-DAQmx includes a collection of programming examples to help you get started developing an application. You can modify example code and save it in an application. You can use examples to develop a new application or add example code to an existing application.

To locate LabVIEW, LabWindows/CVI, Measurement Studio, Visual Basic, and ANSI C examples, refer to the document, *Where Are NI-DAQmx Examples Installed in Windows?*, by going to ni.com/info and entering the Info Code `daqmxexp`.

For additional examples, refer to ni.com/examples.

Analog Input on Simultaneous MIO X Series Devices

Figure 4-25 shows the analog input circuitry of the Simultaneous MIO X Series devices.

Figure 4-25. Simultaneous MIO X Series Analog Input Circuitry

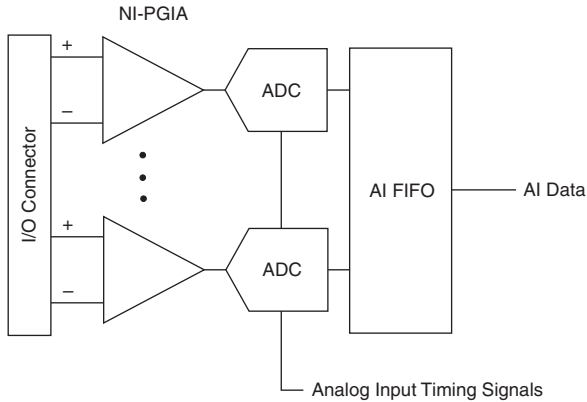

On Simultaneous MIO X Series devices, each channel uses its own instrumentation amplifier, FIFO, multiplexer (mux), and A/D converter (ADC) to achieve simultaneous data acquisition. The main blocks featured in the Simultaneous MIO X Series device analog input circuitry are as follows:

- **I/O Connector**—You can connect analog input signals to the Simultaneous MIO X Series device through the I/O connector. Refer to Appendix A, *Device-Specific Information*, for device I/O connector pinouts.
- **Instrumentation Amplifier (NI-PGIA)**—The NI programmable gain instrumentation amplifier (NI-PGIA) can amplify or attenuate an AI signal to ensure that you get the maximum resolution of the ADC. The NI-PGIA also allows you to select the input range.
- **ADC**—The analog-to-digital converter (ADC) digitizes the AI signal by converting the analog voltage into a digital number.
- **Analog Input Timing Signals**—For information about the analog input timing signals available on Simultaneous MIO X Series devices, refer to the *Analog Input Timing Signals* section.
- **AI FIFO**—Simultaneous MIO X Series devices can perform both single and multiple A/D conversions of a fixed or infinite number of samples. A large first-in-first-out (FIFO) buffer holds data during A/D conversions to ensure that no data is lost. Simultaneous MIO X Series devices can handle multiple A/D conversion operations with DMA or programmed I/O.

Analog Input Terminal Configuration

Simultaneous MIO X Series devices support only differential (DIFF) input mode. The channels on Simultaneous MIO X Series devices are true differential inputs, meaning both positive and negative inputs can carry signals of interest. For more information about DIFF input, refer to the [Connecting Analog Input Signals](#) section, which contains diagrams showing the signal paths for DIFF input mode.



Caution Exceeding the differential and common-mode input ranges distorts the input signals. Exceeding the maximum input voltage rating can damage the device and the computer. NI is *not* liable for any damage resulting from such signal connections. The maximum input voltage ratings can be found in the specifications for each Simultaneous MIO X Series device.

Analog Input Range

Input range refers to the set of input voltages that an analog input channel can digitize with the specified accuracy. The NI-PGIA amplifies or attenuates the AI signal depending on the input range. You can individually program the input range of each AI channel on your Simultaneous MIO X Series device.

The input range affects the resolution of the Simultaneous MIO X Series device for an AI channel. Resolution refers to the voltage of one ADC code. For example, a 16-bit ADC converts analog inputs into one of 65,536 ($= 2^{16}$) codes—that is, one of 65,536 possible digital values. These values are spread fairly evenly across the input range. So, for an input range of -10 V to 10 V, the voltage of each code of a 16-bit ADC is:

$$\frac{10\text{V} - (-10\text{V})}{2^{16}} = 305\ \mu\text{V}$$

Simultaneous MIO X Series devices use a calibration method that requires some codes (typically about 5% of the codes) to lie outside of the specified range. This calibration method improves absolute accuracy, but it increases the nominal resolution of input ranges by about 5% over what the formula shown above would indicate.

Choose an input range that matches the expected input range of your signal. A large input range can accommodate a large signal variation, but reduces the voltage resolution. Choosing a smaller input range improves the voltage resolution, but may result in the input signal going out of range.

For more information about setting ranges, refer to the *NI-DAQmx Help* or the *LabVIEW Help*.

Table 4-6 shows the input ranges and resolutions supported by the Simultaneous MIO X Series device family.

Table 4-6. Simultaneous MIO X Series Device Input Range and Nominal Resolution

Simultaneous MIO X Series Device	Input Range	Nominal Resolution Assuming 5% Over Range
NI 6346/6349/6356/6358/ 6366/6368/6374/ 6376/6378/6386/6396	-10 V to 10 V	320 μ V
	-5 V to 5 V	160 μ V
	-2 V to 2 V	64 μ V
	-1 V to 1 V	32 μ V

Working Voltage Range

On most Simultaneous MIO X Series devices, the PGIA operates normally by amplifying signals of interest while rejecting common-mode signals under the following three conditions:

- The common-mode voltage (V_{cm}), which is equivalent to subtracting AI <0..x> GND from AI <0..x>-, must be less than ± 10 V. This V_{cm} is a constant for all range selections.
- The signal voltage (V_s), which is equivalent to subtracting AI <0..x>+ from AI <0..x>-, must be less than or equal to the range selection of the given channel. If V_s is greater than the range selected, the signal clips and information are lost.
- The total working voltage of the positive input, which is equivalent to ($V_{cm} + V_s$), or subtracting AI <0..x> GND from AI <0..x>+, must be less than ± 11 V. This does not apply to the NI 6346 and NI 6349, which have lower working voltages for lower ranges. Refer to the device specifications on ni.com/manuals for working voltage values per range.

If any of these conditions are exceeded, the input voltage is clamped until the fault condition is removed.

Analog Input Data Acquisition Methods

When performing analog input measurements, you either can perform software-timed or hardware-timed acquisitions.

- **Software-timed acquisitions**—With a software-timed acquisition, software controls the rate of the acquisition. Software sends a separate command to the hardware to initiate each ADC conversion. In NI-DAQmx, software-timed acquisitions are referred to as having on-demand timing. Software-timed acquisitions are also referred to as immediate or static acquisitions and are typically used for reading a single sample of data.
- **Hardware-timed acquisitions**—With hardware-timed acquisitions, a digital hardware signal (AI Sample Clock) controls the rate of the acquisition. This signal can be generated internally on your device or provided externally.

Hardware-timed acquisitions have several advantages over software-timed acquisitions:

- The time between samples can be much shorter.
- The timing between samples is deterministic.
- Hardware-timed acquisitions can use hardware triggering.

Hardware-timed operations can be buffered or hardware-timed single point (HWTSP). A buffer is a temporary storage in computer memory for to-be-transferred samples.

- Buffered—In a buffered acquisition, data is moved from the DAQ device's onboard FIFO memory to a PC buffer using DMA before it is transferred to application memory. Buffered acquisitions typically allow for much faster transfer rates than HWTSP acquisitions because data is moved in large blocks, rather than one point at a time.

One property of buffered I/O operations is the sample mode. The sample mode can be either finite or continuous:

- Finite sample mode acquisition refers to the acquisition of a specific, predetermined number of data samples. Once the specified number of samples has been read in, the acquisition stops. If you use a reference trigger, you must use finite sample mode.



Note (NI USB-6356/6366 and PXIe-6378 Devices) Some X Series devices internally transfer data in sample pairs, as opposed to single samples. This implementation allows for greater data throughput. However, if an acquisition on these devices acquires an odd number of total samples, the last sample acquired cannot be transferred.

To ensure this condition never occurs, NI-DAQmx adds a background channel for finite acquisitions that have both an odd number of channels and an odd number of samples-per-channel. The background channel is also added when performing any reference-triggered finite acquisition. Data from the background channel is only visible when reading in RAW mode.

For maximum efficiency in bus bandwidth and onboard FIFO use, use an even number of samples-per-channel or an even number of channels for finite acquisitions, so the background channel is not added.

- Continuous acquisition refers to the acquisition of an unspecified number of samples. Instead of acquiring a set number of data samples and stopping, a continuous acquisition continues until you stop the operation. Continuous acquisition is also referred to as double-buffered or circular-buffered acquisition. If data cannot be transferred across the bus fast enough, the FIFO becomes full. New acquisitions overwrite data in the FIFO before it can be transferred to host memory, which causes the device to generate an error. With continuous operations, if the user program does not read data out of the PC buffer fast enough to keep up with the data transfer, the buffer could reach an overflow condition, causing an error to be generated.

- Hardware-timed single point (HWTSP)—Typically, HWTSP operations are used to read single samples at known time intervals. While buffered operations are optimized for high throughput, HWTSP operations are optimized for low latency and low jitter. In addition, HWTSP can notify software if it falls behind hardware. These features make HWTSP ideal for real time control applications. HWTSP operations, in conjunction with the wait for next sample clock function, provide tight synchronization between the software layer and the hardware layer. Refer to the *NI-DAQmx Hardware-Timed Single Point Lateness Checking* document for more information. To access this document, go to ni.com/info and enter the Info Code `daqhwtsp`.



Note (NI USB-635x/636x and NI PXIe-6386/6396 Devices) X Series USB and PXIe-6386/6396 devices do *not* support hardware-timed single point (HWTSP) operations. For more information about special considerations for PXIe-6386 and PXIe-6396 devices, go to ni.com/info and enter the Info Code `smio14ms`.

Analog Input Triggering

Analog input supports three different triggering actions:

- Start trigger
- Reference trigger
- Pause trigger

AI tasks will not support pause triggering on these devices.



Note (NI PXIe-6386/6396 Devices) AI tasks do not support pause triggering on PXIe-6386 and PXIe-6396 devices. For more information about special considerations for these devices, go to ni.com/info and enter the Info Code `smio14ms`.

Refer to the *AI Start Trigger Signal*, *AI Reference Trigger Signal*, and *AI Pause Trigger Signal* sections for information about these triggers.

An analog or digital trigger can initiate these actions. All Simultaneous MIO X Series devices support digital triggering, but some do not support analog triggering. To find your device triggering options, refer to the device specifications.

Connecting Analog Input Signals

Table 4-7 summarizes the recommended input configuration for different types of signal sources for Simultaneous MIO X Series devices.

Table 4-7. Simultaneous MIO X Series Analog Input Signal Configuration

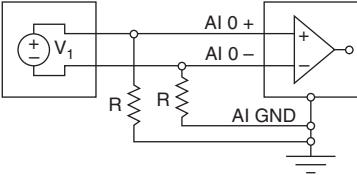
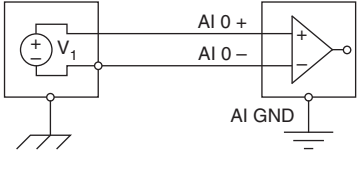
	Floating Signal Sources (Not Connected to Earth Ground)	Ground-Referenced Signal Sources
Input	Examples: <ul style="list-style-type: none"> • Ungrounded thermocouples • Signal conditioning with isolated outputs • Battery devices 	Example: <ul style="list-style-type: none"> • Plug-in instruments with non-isolated outputs
Differential (DIFF)		

Refer to the [Analog Input Terminal Configuration](#) section for descriptions of the input modes.

Types of Signal Sources

When configuring the input channels and making signal connections, first determine whether the signal sources are floating or ground-referenced:

- **Floating Signal Sources**—A floating signal source is not connected in any way to the building ground system, and instead has an isolated ground-reference point. Some examples of floating signal sources are outputs of transformers, thermocouples, battery-powered devices, optical isolators, and isolation amplifiers. An instrument or device that has an isolated output is a floating signal source. You must connect the ground reference of a floating signal to the AI ground of the device to establish a local or onboard reference for the signal. Otherwise, the measured input signal varies as the source floats outside the common-mode input range.
- **Ground-Referenced Signal Sources**—A ground-referenced signal source is connected in some way to the building system ground and is, therefore, already connected to a common ground point with respect to the device, assuming that the computer is plugged into the same power system as the source. Non-isolated outputs of instruments and devices that plug into the building power system fall into this category.

The difference in ground potential between two instruments connected to the same building power system is typically between 1 mV and 100 mV, but the difference can be much

higher if power distribution circuits are improperly connected. If a grounded signal source is incorrectly measured, this difference can appear as measurement error. Follow the connection instructions for grounded signal sources to eliminate this ground potential difference from the measured signal.

Isolated devices have isolated front ends that are isolated from ground-reference signal sources and are not connected to building system grounds. Isolated devices require the user to provide a ground-reference terminal to which its input signals are referenced.

Differential Connections for Ground-Referenced Signal Sources

Figure 4-26 shows how to connect a ground-referenced signal source to a channel on an Simultaneous MIO X Series device.

Figure 4-26. Differential Connection for Ground-Referenced Signals on Simultaneous MIO X Series Devices

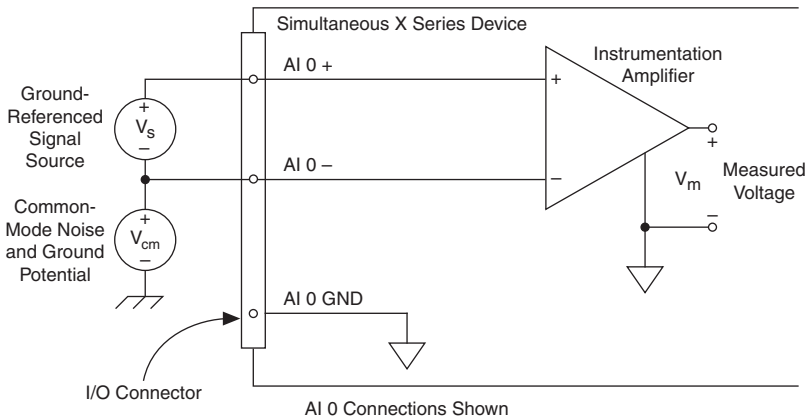

Note (NI USB-6346/6356/6366 BNC Devices) To measure a floating signal source on X Series USB BNC devices, move the switch under the BNC connector to the GS position.

With these types of connections, the instrumentation amplifier rejects both the common-mode noise in the signal and the ground potential difference between the signal source and the device ground, shown as V_{cm} in Figure 4-26.

Common-Mode Signal Rejection Considerations

The instrumentation amplifier can reject any voltage caused by ground potential differences between the signal source and the device. In addition, the instrumentation amplifier can reject common-mode noise pickup in the leads connecting the signal sources to the device. The instrumentation amplifier can reject common-mode signals as long as V_{+in} and V_{-in} (input signals) are both within the working voltage range of the device.

Differential Connections for Floating Signal Sources

Figure 4-27 shows how to connect a floating (or non-referenced) signal source to a channel on an Simultaneous MIO X Series device.

Figure 4-27. Differential Connection for Floating Signals on Simultaneous MIO X Series Devices

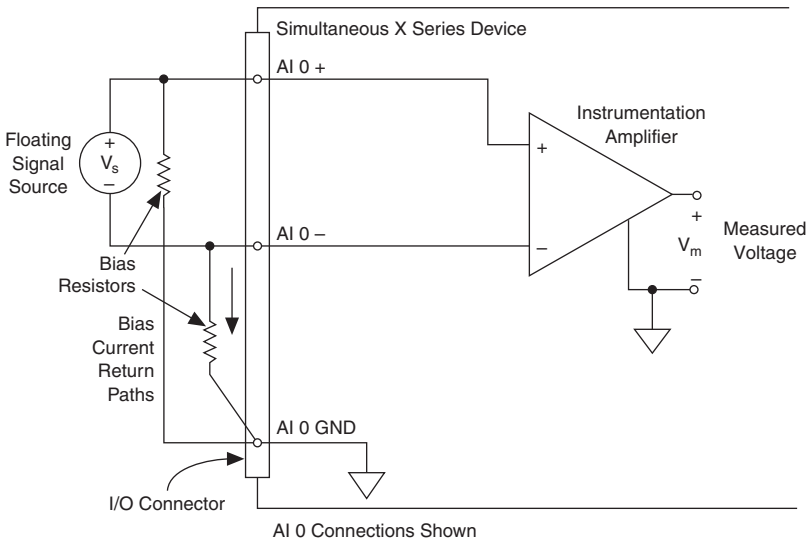

Note (NI USB-6346/6356/6366 BNC Devices) To measure a floating signal source on X Series USB BNC devices, move the switch under the BNC connector to the FS position.

Figure 4-27 shows bias resistors connected between $AI\ 0-$, $AI\ 0+$, and the floating signal source ground. These resistors provide a return path for the bias current. A value of $10\ k\Omega$ to $1\ M\Omega$ is usually sufficient. If you do not use the resistors and the source is truly floating, the source is not likely to remain within the common-mode signal range of the instrumentation amplifier, which saturates the instrumentation amplifier, causing erroneous readings. You must reference the source to the respective channel ground.

DC-Coupled

You can connect low source impedance and high source impedance DC-coupled sources:

- **Low Source Impedance**—You must reference the source to $AI\ GND$. The easiest way to make this reference is to connect the positive side of the signal to the positive input of the instrumentation amplifier and connect the negative side of the signal to $AI\ GND$ as well as

to the negative input of the instrumentation amplifier, without using resistors. This connection works well for DC-coupled sources with low source impedance (less than 100 Ω).

- **High Source Impedance**—For larger source impedances, this connection leaves the DIFF signal path significantly off balance. Noise that couples electrostatically onto the positive line does not couple onto the negative line because it is connected to ground. Hence, this noise appears as a DIFF-mode signal instead of a common-mode signal, and the instrumentation amplifier does not reject it. In this case, instead of directly connecting the negative line to AI GND, connect the negative line to AI GND through a resistor that is about 100 times the equivalent source impedance. The resistor puts the signal path nearly in balance, so that about the same amount of noise couples onto both connections, yielding better rejection of electrostatically coupled noise. This configuration does not load down the source (other than the very high input impedance of the instrumentation amplifier).

You can fully balance the signal path by connecting another resistor of the same value between the positive input and AI GND. This fully balanced configuration offers slightly better noise rejection but has the disadvantage of loading the source down with the series combination (sum) of the two resistors. If, for example, the source impedance is 2 k Ω and each of the two resistors is 100 k Ω , the resistors load down the source with 200 k Ω and produce a -1% gain error.

AC-Coupled

Both inputs of the instrumentation amplifier require a DC path to ground in order for the instrumentation amplifier to work. If the source is AC-coupled (capacitively coupled), the instrumentation amplifier needs a resistor between the positive input and AI GND. If the source has low-impedance, choose a resistor that is large enough not to significantly load the source, but small enough not to produce significant input offset voltage as a result of input bias current (typically 100 k Ω to 1 M Ω). In this case, connect the negative input directly to AI GND. If the source has high output impedance, balance the signal path as previously described using the same value resistor on both the positive and negative inputs; be aware that there is some gain error from loading down the source.

Unused Channels

NI recommends connecting unused channel inputs AI+ and AI- to AIGND. This prevents the inputs from floating outside of the V_{cm} rating, which can generate unnecessary heat and measurement drift. Additionally, open inputs can detect and amplify unwanted environmental noise.

Field Wiring Considerations

Environmental noise can seriously affect the measurement accuracy of the Simultaneous MIO X Series device if you do not take proper care when running signal wires between signal sources and the device. The following recommendations apply mainly to AI signal routing, although they also apply to signal routing in general.

Minimize noise pickup and maximize measurement accuracy by taking the following precautions:

- Use individually shielded, twisted-pair wires to connect AI signals to the device. With this type of wire, the signals attached to the AI+ and AI- inputs are twisted together and then covered with a shield. You then connect this shield only at one point to the signal source ground. This kind of connection is required for signals traveling through areas with large magnetic fields or high electromagnetic interference.
- Route signals to the device carefully. Keep cabling away from noise sources. The most common noise source in a PCI DAQ system is the video monitor. Separate the monitor from the analog signals as far as possible.
- Separate the signal lines of the Simultaneous MIO X Series device from high-current or high-voltage lines. These lines can induce currents in or voltages on the signal lines of the Simultaneous MIO X Series device if they run in close parallel paths. To reduce the magnetic coupling between lines, separate them by a reasonable distance if they run in parallel, or run the lines at right angles to each other.
- Do *not* run signal lines through conduits that also contain power lines.
- Protect signal lines from magnetic fields caused by electric motors, welding equipment, breakers, or transformers by running them through special metal conduits.

Refer to the *Field Wiring and Noise Considerations for Analog Signals* document for more information. To access this document, go to ni.com/info and enter the Info Code `rdfwn3`.

Minimizing Drift in Differential Mode

If the readings from the DAQ device are random and drift rapidly, you should check the ground-reference connections. The signal can be referenced to a level that is considered floating with reference to the device ground reference. Even though you are in DIFF mode, you must still reference the signal to the same ground level as the device reference. There are various methods of achieving this reference while maintaining a high common-mode rejection ratio (CMRR). These methods are outlined in the [Connecting Analog Input Signals](#) section.

AI GND is an AI common signal that routes directly to the ground connection point on the devices. You can use this signal if you need a general analog ground connection point to the device.

Analog Input Timing Signals

In order to provide all of the timing functionality described throughout this section, Simultaneous MIO X Series devices have a flexible timing engine. Refer to the [Clock Routing](#) section of Chapter 9, [Digital Routing and Clock Generation](#).

Simultaneous MIO X Series devices use AI Sample Clock (`ai/SampleClock`) to perform simultaneous sampling on all active analog channels. Since there is one ADC per channel, AI Sample Clock controls the sample period on all the channels in the task.

An acquisition with posttrigger data allows you to view data that is acquired after a trigger event is received. A typical posttrigger DAQ sequence is shown in Figure 4-28. The sample counter is loaded with the specified number of posttrigger samples, in this example, five. The value decrements with each pulse on AI Sample Clock, until all desired samples have been acquired.

Figure 4-28. Typical Posttriggered DAQ Sequence

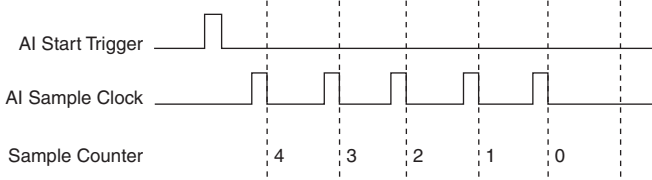

An acquisition with pretrigger data allows you to view data that is acquired before the trigger of interest, in addition to data acquired after the trigger. Figure 4-29 shows a typical pretrigger DAQ sequence. The AI Start Trigger signal (ai/StartTrigger) can be either a hardware or software signal. If AI Start Trigger is set up to be a software start trigger, an output pulse appears on the ai/StartTrigger line when the acquisition begins. When the AI Start Trigger pulse occurs, the sample counter is loaded with the number of pretrigger samples, in this example, four. The value decrements with each pulse on AI Sample Clock. The sample counter is then loaded with the number of posttrigger samples, in this example, three.

Figure 4-29. Typical Pretriggered DAQ Sequence

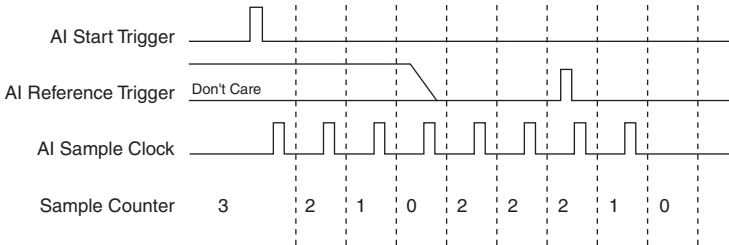

If an AI Reference Trigger (ai/ReferenceTrigger) pulse occurs before the specified number of pretrigger samples are acquired, the trigger pulse is ignored. Otherwise, when the AI Reference Trigger pulse occurs, the sample counter value decrements until the specified number of posttrigger samples have been acquired. For more information about start and reference triggers, refer to the [Analog Input Triggering](#) section.

Simultaneous MIO X Series devices feature the following analog input timing signals:

- [AI Sample Clock Signal*](#)
- [AI Sample Clock Timebase Signal](#)
- [AI Hold Complete Event Signal](#)
- [AI Start Trigger Signal*](#)

- *AI Reference Trigger Signal**
- *AI Pause Trigger Signal**



Note (NI PXIe-6386/6396 Devices) AI tasks do not support pause triggering on PXIe-6386 and PXIe-6396 devices. For more information about special considerations for these devices, go to ni.com/info and enter the Info Code smio14ms.

Signals with an * support digital filtering. Refer to the *PFI Filters* section of Chapter 8, *PFI*, for more information.

Aggregate versus Single Channel Sample Rates

Simultaneous MIO X Series devices have one ADC per channel so the single channel maximum sample rate can be achieved on each channel. The maximum single channel rate is the fastest you can acquire data on the device from a single or multiple channels and still achieve accurate results.

The total aggregate determines the maximum bus bandwidth used by the device. The total aggregate sample rate is the product of the maximum sample rate for a single channel multiplied by the number of AI channels that the device support.

Table 4-8 shows the single channels and total aggregate rates for Simultaneous MIO X Series devices.

Table 4-8. Analog Input Rates for Simultaneous MIO X Series Devices

Simultaneous MIO X Series Device	Analog Input Rate	
	Single Channel	Total Aggregate
NI 6346	500 kS/s	4 MS/s
NI 6349	500 kS/s	16 MS/s
NI 6356	1.25 MS/s	10 MS/s
NI 6358	1.25 MS/s	20 MS/s
NI 6366	2 MS/s	16 MS/s
NI 6368	2 MS/s	32 MS/s
NI 6374	3.57 MS/s	14.28 MS/s
NI 6376	3.57 MS/s	28.56 MS/s
NI 6378	3.57 MS/s	57.12 MS/s
NI 6386	14.29 MS/s*	114.29 MS/s*

Table 4-8. Analog Input Rates for Simultaneous MIO X Series Devices (Continued)

Simultaneous MIO X Series Device	Analog Input Rate	
	Single Channel	Total Aggregate
NI 6396	14.29 MS/s*	114.29 MS/s*
<p>*NI PXIe-6386/6396 devices support the listed analog input rates when using an internal clock. When using an externally-derived clock, the maximum single channel analog input rate is 15 MS/s and the total aggregate rate is 120 MS/s.</p> <p>Note: On Simultaneous MIO X Series devices, each channel has an ADC so each channel can be acquired at the maximum single channel rate.</p>		

AI Sample Clock Signal

Use the AI Sample Clock (ai/SampleClock) signal to initiate a set of measurements. Your Simultaneous MIO X Series device samples the AI signals of every channel in the task once for every AI Sample Clock. A measurement acquisition consists of one or more samples.

You can specify an internal or external source for AI Sample Clock. You can also specify whether the measurement sample begins on the rising edge or falling edge of AI Sample Clock.

Using an Internal Source

One of the following internal signals can drive AI Sample Clock:

- Counter n Internal Output
- AI Sample Clock Timebase (divided down)
- A pulse initiated by host software
- Change Detection Event
- Counter n Sample Clock
- DI Sample Clock (di/SampleClock)
- AO Sample Clock (ao/SampleClock)
- DO Sample Clock (do/SampleClock)

A programmable internal counter divides down the sample clock timebase.

Several other internal signals can be routed to AI Sample Clock through internal routes. Refer to *Device Routing in MAX* in the *NI-DAQmx Help* or the *LabVIEW Help* for more information.

Using an External Source

Use one of the following external signals as the source of AI Sample Clock:

- PFI <0..15>
- RTSI <0..7>
- PXI_STAR

- PXIe_DSTAR<A,B>
- Analog Comparison Event (an analog trigger)



Note (NI PXIe-6386/6396 Devices) PXIe-6386 and PXIe-6396 devices differ in several ways from other SMIO devices. For more information about using an external source with these devices, go to ni.com/info and enter the Info Code `smio14ms`.

Routing AI Sample Clock Signal to an Output Terminal

You can route AI Sample Clock out to any PFI <0..15>, RTSI <0..7>, or PXIe_DSTARC terminal. This pulse is always active high.

All PFI terminals are configured as inputs by default.

Other Timing Requirements

Your DAQ device only acquires data during an acquisition. The device ignores AI Sample Clock when a measurement acquisition is not in progress. During a measurement acquisition, you can cause your DAQ device to ignore AI Sample Clock using the AI Pause Trigger signal.

A counter/timing engine on your device internally generates AI Sample Clock unless you select an external source. AI Start Trigger starts this counter and either software or hardware can stop it once a finite acquisition completes. When using the AI timing engine, you can also specify a configurable delay from AI Start Trigger to the first AI Sample Clock pulse. By default, this delay is set to two ticks of the AI Sample Clock Timebase signal.

Figure 4-30 shows the relationship of AI Sample Clock to AI Start Trigger.

Figure 4-30. AI Sample Clock and AI Start Trigger

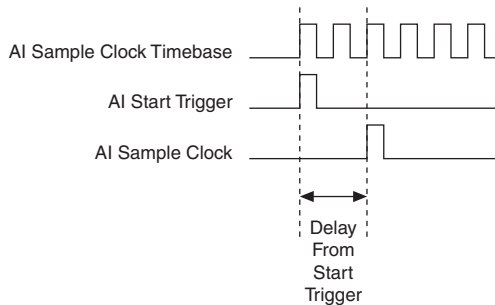

AI Sample Clock Timebase Signal

You can route any of the following signals to be the AI Sample Clock Timebase (`ai/SampleClockTimebase`) signal:

- 100 MHz Timebase (default)
- 20 MHz Timebase

- 100 kHz Timebase
- PXI_CLK10
- RTSI <0..7>
- PFI <0..15>
- PXI_STAR
- PXIe_DSTAR<A,B>
- Analog Comparison Event (an analog trigger)



Note (NI PXIe-6386/6396 Devices) PXIe-6386 and PXIe-6396 devices differ in several ways from other SMIO devices. For more information about these devices related to AI Sample Clocks, go to ni.com/info and enter the Info Code `smio14ms`.

AI Sample Clock Timebase is not available as an output on the I/O connector. AI Sample Clock Timebase is divided down to provide one of the possible sources for AI Sample Clock. You can configure the polarity selection for AI Sample Clock Timebase as either rising or falling edge, except on 100 MHz Timebase or 20 MHz Timebase.

AI Hold Complete Event Signal

The AI Hold Complete Event (`ai/HoldCompleteEvent`) signal generates a pulse after each A/D conversion begins. You can route AI Hold Complete Event out to any PFI <0..15>, RTSI <0..7>, or PXIe_DSTAR terminal.

The polarity of AI Hold Complete Event is software-selectable, but is typically configured so that a low-to-high leading edge can clock external AI multiplexers indicating when the input signal has been sampled and can be removed.

AI Start Trigger Signal

Use the AI Start Trigger (`ai/StartTrigger`) signal to begin a measurement acquisition. A measurement acquisition consists of one or more samples. If you do not use triggers, begin a measurement with a software command. Once the acquisition begins, configure the acquisition to stop:

- When a certain number of points are sampled (in finite mode)
- After a hardware reference trigger (in finite mode)
- With a software command (in continuous mode)

An acquisition that uses a start trigger (but not a reference trigger) is sometimes referred to as a posttriggered acquisition.

Retriggerable Analog Input



Note (PXIe-6386/6396 Devices) PXIe-6386 and PXIe-6396 devices do not currently support retriggerable AI tasks. For more information about special

considerations for these devices, go to ni.com/info and enter the Info Code smio14ms.

The AI Start Trigger is configurable as retriggerable. When the AI Start Trigger is configured as retriggerable, the timing engine generates the sample and convert clocks for the configured acquisition in response to each pulse on an AI Start Trigger signal.

The timing engine ignores the AI Start Trigger signal while the clock generation is in progress. After the clock generation is finished, the counter waits for another Start Trigger to begin another clock generation. Figure 4-31 shows a retriggerable analog input with three AI channels and four samples per trigger.

Figure 4-31. Simultaneous MIO X Series Retriggerable Analog Input

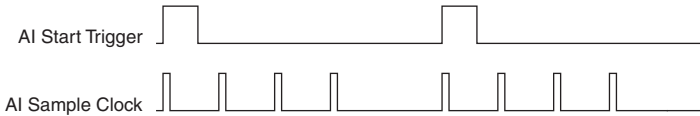

Note Waveform information from LabVIEW does not reflect the delay between triggers. They are treated as a continuous acquisition with constant t_0 and t_1 information.



Note (NI USB-6356/6366 and PXIe-6378 Devices) Some X Series devices internally transfer data in sample pairs, as opposed to single samples. This implementation allows for greater data throughput. However, if an acquisition on these devices acquires an odd number of total samples, the last sample acquired cannot be transferred.

To ensure this condition never occurs, NI-DAQmx adds a background channel for finite acquisitions that have both an odd number of channels and an odd number of samples-per-channel. The background channel is also added when performing any reference-triggered finite acquisition. Data from the background channel is only visible when reading in RAW mode.

For maximum efficiency in bus bandwidth and onboard FIFO use, use an even number of samples-per-channel or an even number of channels for finite acquisitions, so the background channel is not added.

Reference triggers are not retriggerable.

Using a Digital Source

To use AI Start Trigger with a digital source, specify a source and an edge. The source can be any of the following signals:

- PFI <0..15>
- RTSI <0..7>
- Counter *n* Internal Output
- PXI_STAR
- PXIe_DSTAR<A,B>

The source can also be one of several other internal signals on your DAQ device. Refer to *Device Routing in MAX* in the *NI-DAQmx Help* or the *LabVIEW Help* for more information.

You can also specify whether the measurement acquisition begins on the rising edge or falling edge of AI Start Trigger.

Using an Analog Source

When you use an analog trigger source, the acquisition begins on the first rising edge of the Analog Comparison Event signal.

Routing AI Start Trigger to an Output Terminal

You can route AI Start Trigger out to any PFI <0..15>, RTSI <0..7>, or PXIe_DSTARC terminal. The output is an active high pulse. All PFI terminals are configured as inputs by default.

The device also uses AI Start Trigger to initiate pretriggered DAQ operations. In most pretriggered applications, a software trigger generates AI Start Trigger. Refer to the *AI Reference Trigger Signal* section for a complete description of the use of AI Start Trigger and AI Reference Trigger in a pretriggered DAQ operation.

AI Reference Trigger Signal

Use AI Reference Trigger (ai/ReferenceTrigger) signal to stop a measurement acquisition. To use a reference trigger, specify a buffer of finite size and a number of pretrigger samples (samples that occur before the reference trigger). The number of posttrigger samples (samples that occur after the reference trigger) desired is the buffer size minus the number of pretrigger samples.



Note (NI USB-6356/6366 Devices) You can select the buffer on the host or on the NI USB-6356/6366 device. To enable a Reference Trigger to Onboard Memory, set the AI Data Transfer Request Condition property in NI-DAQmx to When Acquisition Complete.

Once the acquisition begins, the DAQ device writes samples to the buffer. After the DAQ device captures the specified number of pretrigger samples, the DAQ device begins to look for the reference trigger condition. If the reference trigger condition occurs before the DAQ device captures the specified number of pretrigger samples, the DAQ device ignores the condition.

If the buffer becomes full, the DAQ device continuously discards the oldest samples in the buffer to make space for the next sample. This data can be accessed (with some limitations) before the DAQ device discards it. Refer to the document, *Can a Pretriggered Analog Acquisition be Continuous?*, for more information. To access this document, go to ni.com/info and enter the Info Code `rdcanq`.

When the reference trigger occurs, the DAQ device continues to write samples to the buffer until the buffer contains the number of posttrigger samples desired. Figure 4-32 shows the final buffer.

Figure 4-32. Reference Trigger Final Buffer

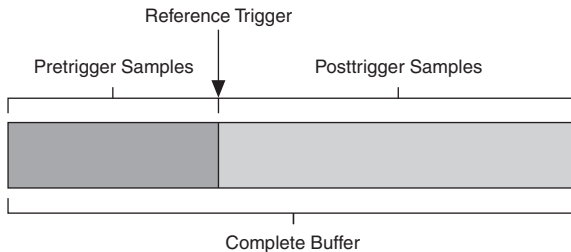

Using a Digital Source

To use AI Reference Trigger with a digital source, specify a source and an edge. The source can be any of the following signals:

- PFI <0..15>
- RTSI <0..7>
- PXI_STAR
- PXIe_DSTAR<A,B>
- Change Detection Event
- Counter *n* Internal Output
- DI Reference Trigger (di/ReferenceTrigger)
- AO Start Trigger (ao/StartTrigger)
- DO Start Trigger (do/StartTrigger)

The source can also be one of several internal signals on your DAQ device. Refer to *Device Routing in MAX* in the *NI-DAQmx Help* or the *LabVIEW Help* for more information.

You can also specify whether the measurement acquisition stops on the rising edge or falling edge of AI Reference Trigger.

Using an Analog Source

When you use an analog trigger source, the acquisition stops on the first rising edge of the Analog Comparison Event signal.

Routing AI Reference Trigger Signal to an Output Terminal

You can route AI Reference Trigger out to any PFI <0..15>, RTSI <0..7>, PXI_Trig <0..7>, or PXIe_DSTARC terminal.

All PFI terminals are configured as inputs by default.

AI Pause Trigger Signal



Note (NI PXIe-6386/6396 Devices) AI tasks do not support pause triggering on PXIe-6386 and PXIe-6396 devices. For more information about special considerations for these devices, go to ni.com/info and enter the Info Code smio14ms.

Use the AI Pause Trigger (ai/PauseTrigger) signal to pause and resume a measurement acquisition. The internal sample clock pauses while the external trigger signal is active and resumes when the signal is inactive. You can program the active level of the pause trigger to be high or low, as shown in Figure 4-33. In the figure, T represents the period, and A represents the unknown time between the clock pulse and the posttrigger.

Figure 4-33. Halt (Internal Clock) and Free Running (External Clock)

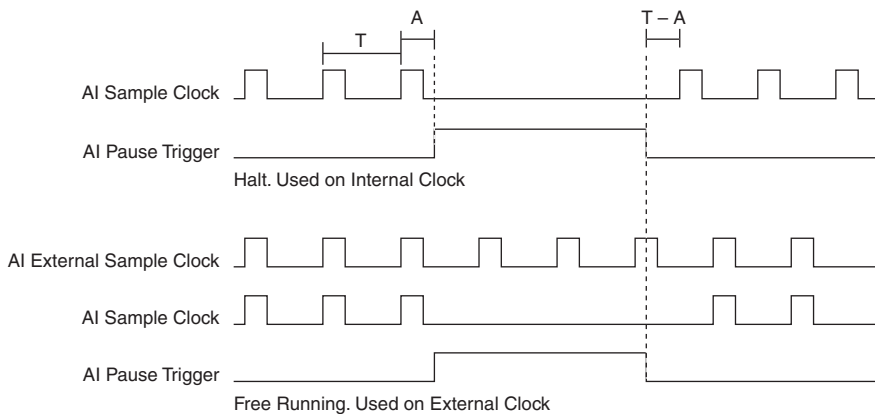

Using a Digital Source

To use AI Pause Trigger, specify a source and a polarity. The source can be any of the following signals:

- PFI <0..15>
- RTSI <0..7>
- PXI_STAR
- PXIe_DSTAR<A,B>
- Counter *n* Internal Output
- Counter *n* Gate
- AO Pause Trigger (ao/PauseTrigger)
- DI Pause Trigger (di/PauseTrigger)
- DO Pause Trigger (do/PauseTrigger)

The source can also be one of several other internal signals on your DAQ device. Refer to *Device Routing in MAX* in the *NI-DAQmx Help* or the *LabVIEW Help* for more information.

Using an Analog Source

When you use an analog trigger source, the internal sample clock pauses when the Analog Comparison Event signal is low and resumes when the signal goes high (or vice versa).

Routing AI Pause Trigger Signal to an Output Terminal

You can route AI Pause Trigger out to any PFI <0..15>, RTSI <0..7>, PXI_STAR, or PXIe_DSTARC terminal.



Note Pause triggers are only sensitive to the level of the source, not the edge.

Getting Started with AI Applications in Software

You can use the Simultaneous MIO X Series device in the following analog input applications:

- Simultaneous sampling
- Single-point analog input
- Finite analog input
- Continuous analog input

You can perform these applications through DMA or programmed I/O data transfer mechanisms. Some of the applications also use start and reference pause triggers.



Note For more information about programming analog input applications and triggers in software, refer to the *NI-DAQmx Help* or the *LabVIEW Help* in version 8.0 or later.

Simultaneous MIO X Series devices use the NI-DAQmx driver. NI-DAQmx includes a collection of programming examples to help you get started developing an application. You can modify example code and save it in an application. You can use examples to develop a new application or add example code to an existing application.

To locate LabVIEW, LabWindows/CVI, Measurement Studio, Visual Basic, and ANSI C examples, refer to the document, *Where Are NI-DAQmx Examples Installed in Windows?*, by going to ni.com/info and entering the Info Code `daqmxexp`.

For additional examples, refer to ni.com/examples.

Analog Output

Many X Series devices have analog output functionality. X Series devices that support analog output have either two or four AO channels that are controlled by a single clock and are capable of waveform generation. Refer to Appendix A, *Device-Specific Information*, for information about the capabilities of your device.

Figure 5-1 shows the analog output circuitry of X Series devices.

Figure 5-1. X Series Analog Output Circuitry

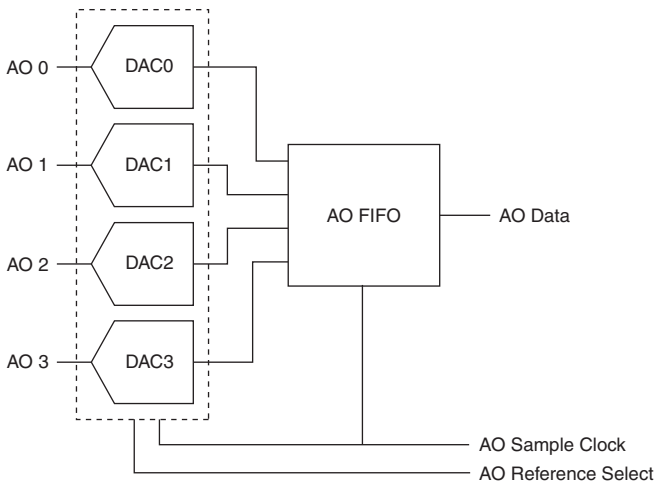

The main blocks featured in the X Series analog output circuitry are as follows:

- **DACs**—Digital-to-analog converters (DACs) convert digital codes to analog voltages.
- **AO FIFO**—The AO FIFO enables analog output waveform generation. It is a first-in-first-out (FIFO) memory buffer between the computer and the DACs. It allows you to download the points of a waveform to your X Series device without host computer interaction.
- **AO Sample Clock**—The AO Sample Clock signal reads a sample from the DAC FIFO and generates the AO voltage.
- **AO Reference Selection**—The AO reference selection signal allows you to change the range of the analog outputs.

AO Reference Selection

AO reference selection allows you to set the analog output range. The analog output range describes the set of voltages the device can generate. The digital codes of the DAC are spread evenly across the analog output range. So, if the range is smaller, the analog output has better resolution; that is, the voltage output difference between two consecutive codes is smaller. Therefore, the analog output is more accurate.

The analog output range of a device is all of the voltages between:

-AO Reference and +AO Reference

The possible settings for AO reference depend on the device model. For models not described below, refer to the device specifications.

- **(NI 6321/6323/6341/6343/6346/6349 Devices)** The AO reference is always 10 V. The analog output range equals ± 10 V.
- **(NI 6345/635x/636x/637x/6386/6396 Devices)** The AO reference of each analog output (AO <0..3>) can be individually set to one of the following:
 - 10 V
 - 5 V
 - APFI <0,1>

You can connect an external signal to APFI <0,1> to provide the AO reference. The AO reference can be a positive or negative voltage. If AO reference is a negative voltage, the polarity of the AO output is inverted. The valid ranges of APFI <0,1> are listed in the device specifications.

You can use one of the AO <0..3> signals to be the AO reference for a different AO signal. However, you must externally connect this channel to APFI 0 or APFI 1.



Note When using an external reference, the output signal is not calibrated in software. You can generate a value and measure the voltage offset to calibrate your output in software.

Minimizing Glitches on the Output Signal

When you use a DAC to generate a waveform, you may observe glitches on the output signal. These glitches are normal; when a DAC switches from one voltage to another, it produces glitches due to released charges. The largest glitches occur when the most significant bit of the DAC code changes. You can build a lowpass deglitching filter to remove some of these glitches, depending on the frequency and nature of the output signal. Visit ni.com/support for more information about minimizing glitches.

Analog Output Data Generation Methods

When performing an analog output operation, you can perform software-timed or hardware-timed generations.

Software-Timed Generations

With a software-timed generation, software controls the rate at which data is generated. Software sends a separate command to the hardware to initiate each DAC conversion. In NI-DAQmx, software-timed generations are referred to as on-demand timing. Software-timed generations are also referred to as immediate or static operations. They are typically used for writing a single value out, such as a constant DC voltage.

Hardware-Timed Generations

With a hardware-timed generation, a digital hardware signal controls the rate of the generation. This signal can be generated internally on your device or provided externally.

Hardware-timed generations have several advantages over software-timed generations:

- The time between samples can be much shorter.
- The timing between samples can be deterministic.
- Hardware-timed acquisitions can use hardware triggering.

Hardware-timed operations can be buffered or hardware-timed single point (HWTSP). A buffer is a temporary storage in computer memory for to-be-transferred samples.

- **Hardware-timed single point (HWTSP)**—Typically, HWTSP operations are used to write single samples at known time intervals. While buffered operations are optimized for high throughput, HWTSP operations are optimized for low latency and low jitter. In addition, HWTSP can notify software if it falls behind hardware. These features make HWTSP ideal for real time control applications. HWTSP operations, in conjunction with the wait for next sample clock function, provide tight synchronization between the software layer and the hardware layer. Refer to the *NI-DAQmx Hardware-Timed Single Point Lateness Checking* document for more information. To access this document, go to ni.com/info and enter the Info Code `daqhwtsp`.



Note (NI USB-63xx Devices) USB X Series devices do not support hardware-timed single point (HWTSP) operations.

- **Buffered**—In a buffered generation, data is moved from a PC buffer to the DAQ device's onboard FIFO using DMA before it is written to the DACs one sample at a time. Buffered generation typically allow for much faster transfer rates than non-buffered acquisitions because data is moved in large blocks, rather than one point at a time.

One property of buffered I/O operations is the sample mode. The sample mode can be either finite or continuous:

- Finite sample mode generation refers to the generation of a specific, predetermined number of data samples. Once the specified number of samples has been written out, the generation stops.
- Continuous generation refers to the generation of an unspecified number of samples. Instead of generating a set number of data samples and stopping, a continuous generation continues until you stop the operation. There are several different methods of continuous generation that control what data is written. These methods are regeneration, FIFO regeneration and non-regeneration modes:
 - Regeneration is the repetition of the data that is already in the buffer. Standard regeneration is when data from the PC buffer is continually downloaded to the FIFO to be written out. New data can be written to the PC buffer at any time without disrupting the output. Use the NI-DAQmx write property RegenMode to allow (or not allow) regeneration. The NI-DAQmx default is to allow regeneration.
 - With FIFO regeneration, the entire buffer is downloaded to the FIFO and regenerated from there. Once the data is downloaded, new data cannot be written to the FIFO. To use FIFO regeneration, the entire buffer must fit within the FIFO size. The advantage of using FIFO regeneration is that it does not require communication with the main host memory once the operation is started, thereby preventing any problems that may occur due to excessive bus traffic. Use the NI-DAQmx AO channel property, UseOnlyOnBoardMemory to enable or disable FIFO regeneration.
 - With non-regeneration, old data is not repeated. New data must be continually written to the buffer. If the program does not write new data to the buffer at a fast enough rate to keep up with the generation, the buffer underflows and causes an error.

Analog Output Triggering

Analog output supports two different triggering actions:

- Start trigger
- Pause trigger

An analog or digital trigger can initiate these actions. All X Series devices support digital triggering, but some do not support analog triggering. To find your device's triggering options, refer to the device specifications. Refer to the [AO Start Trigger Signal](#) and [AO Pause Trigger Signal](#) sections for more information about these triggering actions.

Connecting Analog Output Signals

AO <0..3> are the voltage output signals for analog output channels 0, 1, 2, and 3. AO GND is the ground reference for AO <0..3>.

Figure 5-2 shows how to make analog output connections to the device.

Figure 5-2. Analog Output Connections

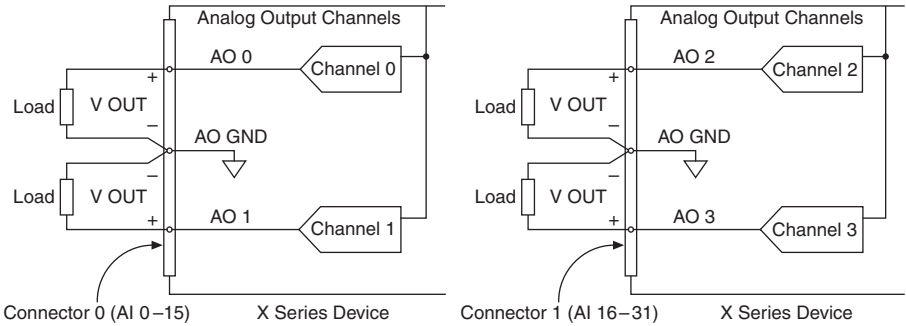

Analog Output Timing Signals

Figure 5-3 summarizes all of the timing options provided by the analog output timing engine.

Figure 5-3. Analog Output Timing Options

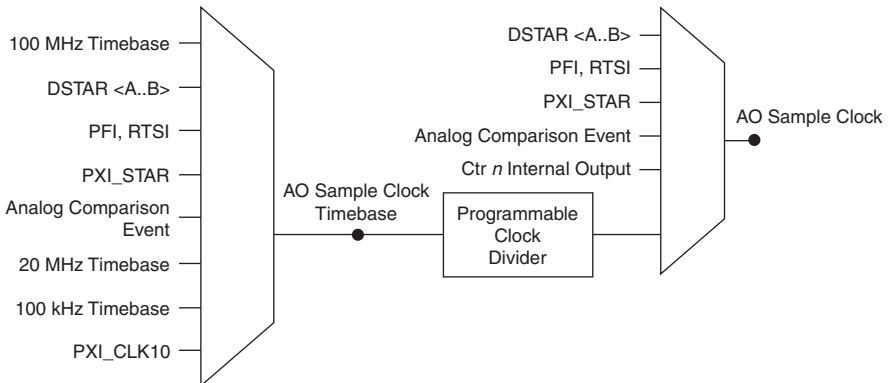

X Series devices feature the following analog output (waveform generation) timing signals:

- *AO Start Trigger Signal**
- *AO Pause Trigger Signal**
- *AO Sample Clock Signal**
- *AO Sample Clock Timebase Signal*

Signals with an * support digital filtering. Refer to the *PFI Filters* section of Chapter 8, *PFI*, for more information.

AO Start Trigger Signal

Use the AO Start Trigger (ao/StartTrigger) signal to initiate a waveform generation. If you do not use triggers, you can begin a generation with a software command.

Retriggerable Analog Output

The AO Start Trigger is configurable as retriggerable. The timing engine generates the sample clock for the configured generation in response to each pulse on an AO Start Trigger signal.

The timing engine ignores the AO Start Trigger signal while the clock generation is in progress. After the clock generation is finished, the counter waits for another Start Trigger to begin another clock generation.

Figure 5-4 shows a retriggerable AO generation of four samples.

Figure 5-4. Retriggerable Analog Output

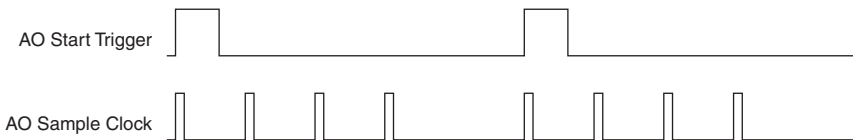

Using a Digital Source

To use AO Start Trigger, specify a source and an edge. The source can be one of the following signals:

- A pulse initiated by host software
- PFI <0..15>
- RTSI <0..7>
- AI Start Trigger (ai/StartTrigger)
- AI Reference Trigger (ai/ReferenceTrigger)
- PXI_STAR
- PXIe_DSTAR<A,B>
- Counter *n* Internal Output
- Change Detection Event
- DI Start Trigger (di/StartTrigger)
- DI Reference Trigger (di/ReferenceTrigger)
- DO Start Trigger (do/StartTrigger)

The source can also be one of several internal signals on your DAQ device. Refer to *Device Routing in MAX* in the *NI-DAQmx Help* or the *LabVIEW Help* for more information.

You can also specify whether the waveform generation begins on the rising edge or falling edge of AO Start Trigger.

Using an Analog Source

When you use an analog trigger source, the waveform generation begins on the first rising edge of the Analog Comparison Event signal. Refer to the [Triggering with an Analog Source](#) section of Chapter 11, [Triggering](#), for more information.

Routing AO Start Trigger Signal to an Output Terminal

You can route AO Start Trigger out to any PFI <0..15>, RTSI <0..7>, or PXIe_DSTARC terminal.

The output is an active high pulse. PFI terminals are configured as inputs by default.

AO Pause Trigger Signal

Use the AO Pause Trigger (ao/PauseTrigger) signal to mask off samples in a DAQ sequence. That is, when AO Pause Trigger is active, no samples occur.

AO Pause Trigger does not stop a sample that is in progress. The pause does not take effect until the beginning of the next sample.

When you generate analog output signals, the generation pauses as soon as the pause trigger is asserted. If the source of your sample clock is the onboard clock, the generation resumes as soon as the pause trigger is deasserted, as shown in Figure 5-5.

Figure 5-5. AO Pause Trigger with the Onboard Clock Source

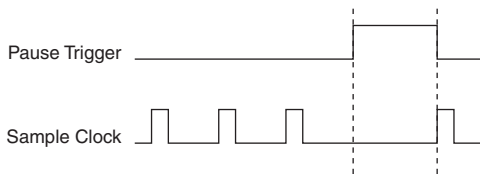

If you are using any signal other than the onboard clock as the source of your sample clock, the generation resumes as soon as the pause trigger is deasserted and another edge of the sample clock is received, as shown in Figure 5-6.

Figure 5-6. AO PauseTrigger with Other Signal Source

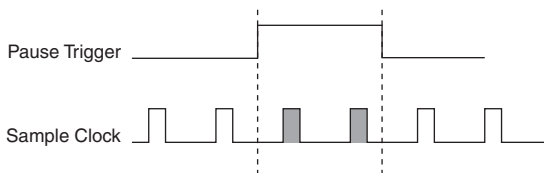

Using a Digital Source

To use AO Pause Trigger, specify a source and a polarity. The source can be one of the following signals:

- PFI <0..15>
- RTSI <0..7>
- PXI_STAR
- PXIe_DSTAR<A,B>
- Counter n Internal Output
- Counter n Gate
- AI Pause Trigger (ai/PauseTrigger)
- DI Pause Trigger (di/PauseTrigger)
- DO Pause Trigger (do/PauseTrigger)

The source can also be one of several other internal signals on your DAQ device. Refer to *Device Routing in MAX* in the *NI-DAQmx Help* or the *LabVIEW Help* for more information.

You can also specify whether the samples are paused when AO Pause Trigger is at a logic high or low level.

Using an Analog Source

When you use an analog trigger source, the samples are paused when the Analog Comparison Event signal is at a high level. Refer to the [Triggering with an Analog Source](#) section of Chapter 11, [Triggering](#), for more information.

Routing AO Pause Trigger Signal to an Output Terminal

You can route AO Pause Trigger out to any PFI <0..15>, RTSI <0..7>, or PXIe_DSTARC terminal.

AO Sample Clock Signal

Use the AO Sample Clock (ao/SampleClock) signal to initiate AO samples. Each sample updates the outputs of all of the DACs. You can specify an internal or external source for AO Sample Clock. You can also specify whether the DAC update begins on the rising edge or falling edge of AO Sample Clock.

Using an Internal Source

One of the following internal signals can drive AO Sample Clock:

- AO Sample Clock Timebase (divided down)
- Counter n Internal Output
- Change Detection Event
- Counter n Sample Clock

- AI Convert Clock (ai/ConvertClock)
- AI Sample Clock (ai/SampleClock)
- DI Sample Clock (di/SampleClock)
- DO Sample Clock (do/SampleClock)

A programmable internal counter divides down the AO Sample Clock Timebase signal.

Several other internal signals can be routed to AO Sample Clock through internal routes. Refer to *Device Routing in MAX* in the *NI-DAQmx Help* or the *LabVIEW Help* for more information.

Using an External Source

Use one of the following external signals as the source of AO Sample Clock:

- PFI <0..15>
- RTSI <0..7>
- PXI_STAR
- PXIe_DSTAR<A,B>
- Analog Comparison Event (an analog trigger)

Routing AO Sample Clock Signal to an Output Terminal

You can route AO Sample Clock (as an active low signal) out to any PFI <0..15>, RTSI <0..7>, or PXIe_DSTAR terminal.

Other Timing Requirements

The AO timing engine on your device internally generates AO Sample Clock unless you select some external source. AO Start Trigger starts the timing engine and either the software or hardware can stop it once a finite generation completes. When using the AO timing engine, you can also specify a configurable delay from AO Start Trigger to the first AO Sample Clock pulse. By default, this delay is two ticks of AO Sample Clock Timebase.

Figure 5-7 shows the relationship of AO Sample Clock to AO Start Trigger.

Figure 5-7. AO Sample Clock and AO Start Trigger

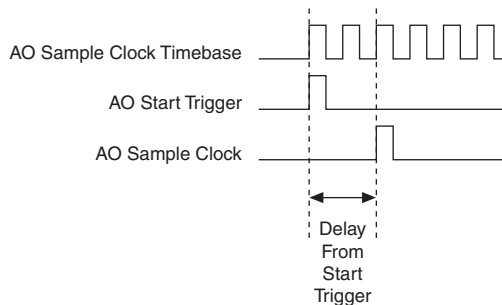

AO Sample Clock Timebase Signal

The AO Sample Clock Timebase (ao/SampleClockTimebase) signal is divided down to provide a source for AO Sample Clock.

You can route any of the following signals to be the AO Sample Clock Timebase signal:

- 100 MHz Timebase (default)
- 20 MHz Timebase
- 100 kHz Timebase
- PXI_CLK10
- PFI <0..15>
- RTSI <0..7>
- PXI_STAR
- PXIe_DSTAR<A,B>
- Analog Comparison Event (an analog trigger)

AO Sample Clock Timebase is not available as an output on the I/O connector.

You can use an external sample clock signal as AO Sample Clock Timebase signal by dividing the signal down in a DAQ device. You can also use it as AO Sample Clock signal without dividing the signal.

Getting Started with AO Applications in Software

You can use an X Series device in the following analog output applications:

- Single-point (on-demand) generation
- Finite generation
- Continuous generation
- Waveform generation

You can perform these generations through programmed I/O or DMA data transfer mechanisms. Some of the applications also use start triggers and pause triggers.



Note For more information about programming analog output applications and triggers in software, refer to the *NI-DAQmx Help* or the *LabVIEW Help*.

X Series devices use the NI-DAQmx driver. NI-DAQmx includes a collection of programming examples to help you get started developing an application. You can modify example code and save it in an application. You can use examples to develop a new application or add example code to an existing application.

To locate LabVIEW, LabWindows/CVI, Measurement Studio, Visual Basic, and ANSI C examples, refer to the document, *Where Are NI-DAQmx Examples Installed in Windows?*, by going to ni.com/info and entering the Info Code `daqmexp`.

For additional examples, refer to ni.com/examples.

Digital I/O

X Series devices contain up to 32 lines of bidirectional DIO signals on Port 0. In addition, X Series devices have up to 16 PFI signals that can function as static DIO signals.

X Series devices support the following DIO features on Port 0:

- Up to 32 lines of DIO
- Direction and function of each terminal individually controllable
- Static digital input and output
- High-speed digital waveform generation
- High-speed digital waveform acquisition
- DI change detection trigger/interrupt

Figure 6-1 shows the circuitry of one DIO line. Each DIO line is similar. The following sections provide information about the various parts of the DIO circuit.

Figure 6-1. X Series Digital I/O Circuitry

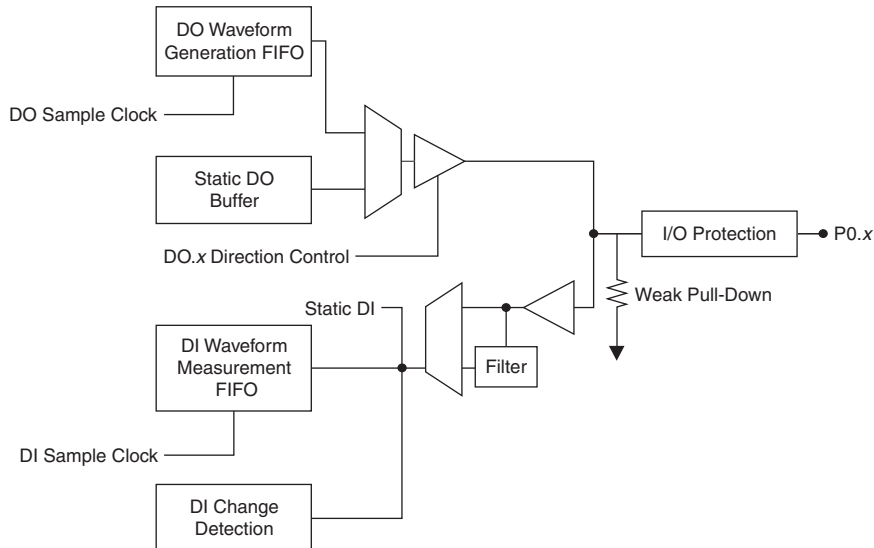

The DIO terminals are named P0.<0..31> on the X Series device I/O connector.

The voltage input and output levels and the current drive levels of the DIO lines are listed in the device specifications.

Digital Input Data Acquisition Methods

When performing digital input measurements, you either can perform software-timed or hardware-timed acquisitions.

Software-Timed Acquisitions

With a software-timed acquisition, software controls the rate of the acquisition. Software sends a separate command to the hardware to initiate each acquisition. In NI-DAQmx, software-timed acquisitions are referred to as having on-demand timing. Software-timed acquisitions are also referred to as immediate or static acquisitions and are typically used for reading a single sample of data.

Each of the X Series DIO lines can be used as a static DI or DO line. You can use static DIO lines to monitor or control digital signals. Each DIO can be individually configured as a digital input (DI) or digital output (DO).

All samples of static DI lines and updates of static DO lines are software-timed.

Hardware-Timed Acquisitions

With hardware-timed acquisitions, a digital hardware signal (`di/SampleClock`) controls the rate of the acquisition. This signal can be generated internally on your device or provided externally.

Hardware-timed acquisitions have several advantages over software-timed acquisitions.

- The time between samples can be much shorter.
- The timing between samples is deterministic.
- Hardware-timed acquisitions can use hardware triggering.

Hardware-timed operations can be buffered or hardware-timed single point. A buffer is a temporary storage in computer memory for to-be-transferred samples.

- **Buffered**—Data is moved from the DAQ device's onboard FIFO memory to a PC buffer using DMA before it is transferred to application memory. Buffered acquisitions typically allow for much faster transfer rates than non-buffered acquisitions because data is moved in large blocks, rather than one point at a time.

One property of buffered I/O operations is the sample mode. The sample mode can be either finite or continuous:

- Finite sample mode acquisition refers to the acquisition of a specific, predetermined number of data samples. Once the specified number of samples has been read in, the acquisition stops. If you use a reference trigger, you must use finite sample mode.

- Continuous acquisition refers to the acquisition of an unspecified number of samples. Instead of acquiring a set number of data samples and stopping, a continuous acquisition continues until you stop the operation. Continuous acquisition is also referred to as double-buffered or circular-buffered acquisition.

If data cannot be transferred across the bus fast enough, the FIFO becomes full. New acquisitions overwrite data in the FIFO before it can be transferred to host memory, which causes the device to generate an error. With continuous operations, if the user program does not read data out of the PC buffer fast enough to keep up with the data transfer, the buffer could reach an overflow condition, causing an error to be generated.

- **Hardware-timed single point (HWTSP)**—Typically, HWTSP operations are used to read single samples at known time intervals. While buffered operations are optimized for high throughput, HWTSP operations are optimized for low latency and low jitter. In addition, HWTSP can notify software if it falls behind hardware. These features make HWTSP ideal for real time control applications. HWTSP operations, in conjunction with the wait for next sample clock function, provide tight synchronization between the software layer and the hardware layer. Refer to the *NI-DAQmx Hardware-Timed Single Point Lateness Checking* document for more information. To access this document, go to ni.com/info and enter the Info Code `daqhwtsp`.



Note (NI USB-634x/635x/636x Devices) X Series USB devices do not support hardware-timed single point (HWTSP) operations.

Digital Input Triggering

Digital input supports three different triggering actions:

- Start trigger
- Reference trigger
- Pause trigger

Refer to the *DI Start Trigger Signal*, *DI Reference Trigger Signal*, and *DI Pause Trigger Signal* sections for information about these triggers.

An analog or digital trigger can initiate these actions. All X Series devices support digital triggering, but some do not support analog triggering. To find your device triggering options, refer to the device specifications.

Digital Waveform Acquisition

Figure 6-2 summarizes all of the timing options provided by the digital input timing engine.

Figure 6-2. Digital Input Timing Options

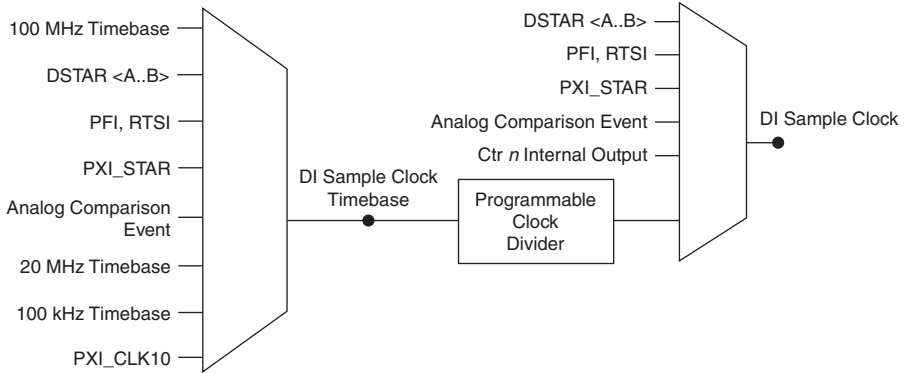

You can acquire digital waveforms on the Port 0 DIO lines. The DI waveform acquisition FIFO stores the digital samples. X Series devices have a DMA controller dedicated to moving data from the DI waveform acquisition FIFO to system memory. The DAQ device samples the DIO lines on each rising or falling edge of a clock signal, DI Sample Clock.

You can configure each DIO line to be an output, a static input, or a digital waveform acquisition input.

X Series devices feature the following digital input timing signals:

- *DI Sample Clock Signal**
- *DI Sample Clock Timebase Signal*
- *DI Start Trigger Signal**
- *DI Reference Trigger Signal**
- *DI Pause Trigger Signal**

Signals with an * support digital filtering. Refer to the *PFI Filters* section of Chapter 8, *PFI*, for more information.

DI Sample Clock Signal

The device uses the DI Sample Clock (di/SampleClock) signal to sample the Port 0 terminals and store the result in the DI waveform acquisition FIFO.

You can specify an internal or external source for DI Sample Clock. You can also specify whether the measurement sample begins on the rising edge or falling edge of DI Sample Clock.

If the DAQ device receives a DI Sample Clock when the FIFO is full, it reports an overflow error to the host software.

Using an Internal Source

To use DI Sample Clock with an internal source, specify the signal source and the polarity of the signal. The source can be any of the following signals:

- DI Sample Clock (di/SampleClock)
- DO Sample Clock (do/SampleClock)
- AI Sample Clock (ai/SampleClock)
- AI Convert Clock (ai/ConvertClock)
- AO Sample Clock (ao/SampleClock)
- Counter n Sample Clock
- Counter n Internal Output
- Frequency Output
- DI Change Detection output

Several other internal signals can be routed to DI Sample Clock through internal routes. Refer to *Device Routing in MAX* in the *NI-DAQmx Help* or the *LabVIEW Help* for more information.

Using an External Source

You can route any of the following signals as DI Sample Clock:

- PFI <0..15>
- RTSI <0..7>
- PXI_STAR
- PXIe_DSTAR<A,B>
- Analog Comparison Event (an analog trigger)

You can sample data on the rising or falling edge of DI Sample Clock.

Routing DI Sample Clock to an Output Terminal

You can route DI Sample Clock out to any PFI <0..15> terminal. The PFI circuitry inverts the polarity of DI Sample Clock before driving the PFI terminal.

Other Timing Requirements

Your DAQ device only acquires data during an acquisition. The device ignores DI Sample Clock when a measurement acquisition is not in progress. During a measurement acquisition, you can cause your DAQ device to ignore DI Sample Clock using the DI Pause Trigger signal.

The DI timing engine on your device internally generates DI Sample Clock unless you select an external source. DI Start Trigger starts the timing engine and either software or hardware can

stop it once a finite acquisition completes. When using the DI timing engine, you can also specify a configurable delay from DI Start Trigger to the first DI Sample Clock pulse.

By default, this delay is set to two ticks of the DI Sample Clock Timebase signal.

Figure 6-3. DI Sample Clock and DI Start Trigger

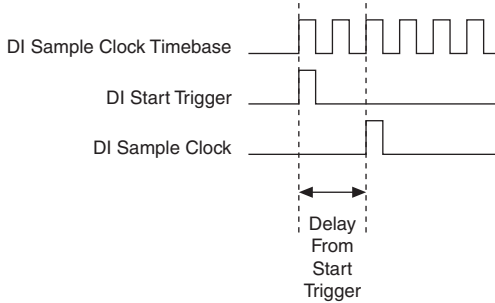

DI Sample Clock Timebase Signal

You can route any of the following signals to be the DI Sample Clock Timebase (di/SampleClockTimebase) signal:

- 100 MHz Timebase (default)
- 20 MHz Timebase
- 100 kHz Timebase
- PXI_CLK10
- RTSI <0..7>
- PFI <0..15>
- PXI_STAR
- PXIe_DSTAR<A,B>
- Analog Comparison Event (an analog trigger)

Refer to the device routing table in MAX for all additional routable signals. To find the device routing table for your device, launch MAX and select **Devices and Interfaces»NI-DAQmx Devices**. Click a device to open a tabbed window in the middle pane. Click the **Device Routes** tab at the bottom of the pane to display the device routing table.

DI Sample Clock Timebase is not available as an output on the I/O connector. DI Sample Clock Timebase is divided down to provide one of the possible sources for DI Sample Clock. You can configure the polarity selection for DI Sample Clock Timebase as either rising or falling edge except for the 100 MHz Timebase or 20 MHz Timebase.

You might use DI Sample Clock Timebase if you want to use an external sample clock signal, but need to divide the signal down. If you want to use an external sample clock signal, but do

not need to divide the signal, then you should use DI Sample Clock rather than DI Sample Clock Timebase.

DI Start Trigger Signal

Use the DI Start Trigger (di/StartTrigger) signal to begin a measurement acquisition. A measurement acquisition consists of one or more samples. If you do not use triggers, begin a measurement with a software command. Once the acquisition begins, configure the acquisition to stop:

- When a certain number of points are sampled (in finite mode)
- After a hardware reference trigger (in finite mode)
- With a software command (in continuous mode)

An acquisition that uses a start trigger (but not a reference trigger) is sometimes referred to as a posttriggered acquisition.

Retriggerable DI

The DI Start Trigger is configurable as retriggerable. When the DI Start Trigger is configured as retriggerable, the timing engine generates the sample and convert clocks for the configured acquisition in response to each pulse on a DI Start Trigger signal.

The timing engine ignores the DI Start Trigger signal while the clock generation is in progress. After the clock generation is finished, the timing engine waits for another Start Trigger to begin another clock generation. Figure 6-4 shows a retriggerable DI of four samples.

Figure 6-4. Retriggerable DI

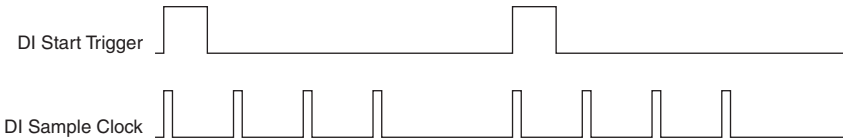

Note Waveform information from LabVIEW does not reflect the delay between triggers. They are treated as a continuous acquisition with constant t_0 and dt information.

Reference triggers are not retriggerable.

Using a Digital Source

To use DI Start Trigger with a digital source, specify a source and an edge. The source can be any of the following signals:

- PFI <0..15>
- RTSI <0..7>
- Counter n Internal Output

- PXI_STAR
- PXIe_DSTAR<A,B>
- Change Detection Event
- AI Start Trigger (ai/StartTrigger)
- AO Start Trigger (ao/StartTrigger)
- DO Start Trigger (do/StartTrigger)

The source can also be one of several other internal signals on your DAQ device. Refer to *Device Routing in MAX* in the *NI-DAQmx Help* or the *LabVIEW Help* for more information.

You can also specify whether the measurement acquisition begins on the rising edge or falling edge of DI Start Trigger.

Using an Analog Source

When you use an analog trigger source, the acquisition begins on the first rising or falling edge of the Analog Comparison Event signal.

Routing DI Start Trigger to an Output Terminal

You can route DI Start Trigger out to any PFI <0..15>, RTSI <0..7>, or PXIe_DSTARC terminal. The output is an active high pulse. All PFI terminals are configured as inputs by default.

The device also uses DI Start Trigger to initiate pretriggered DAQ operations. In most pretriggered applications, a software trigger generates DI Start Trigger. Refer to the [DI Reference Trigger Signal](#) section for a complete description of the use of DI Start Trigger and DI Reference Trigger in a pretriggered DAQ operation.

DI Reference Trigger Signal

Use the DI Reference Trigger (di/ReferenceTrigger) signal to stop a measurement acquisition. To use a reference trigger, specify a buffer of finite size and a number of pretrigger samples (samples that occur before the reference trigger). The number of posttrigger samples (samples that occur after the reference trigger) desired is the buffer size minus the number of pretrigger samples.

Once the acquisition begins, the DAQ device writes samples to the buffer. After the DAQ device captures the specified number of pretrigger samples, the DAQ device begins to look for the reference trigger condition. If the reference trigger condition occurs before the DAQ device captures the specified number of pretrigger samples, the DAQ device ignores the condition.

If the buffer becomes full, the DAQ device continuously discards the oldest samples in the buffer to make space for the next sample. This data can be accessed (with some limitations) before the DAQ device discards it. Refer to the document, *Can a Pretriggered Analog Acquisition be Continuous?*, for more information. To access this document, go to ni.com/info and enter the Info Code `rdcanq`.

When the reference trigger occurs, the DAQ device continues to write samples to the buffer until the buffer contains the number of posttrigger samples desired. Figure 6-5 shows the final buffer.

Figure 6-5. Reference Trigger Final Buffer

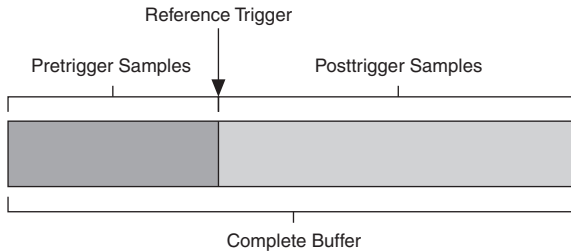

Using a Digital Source

To use DI Reference Trigger with a digital source, specify a source and an edge. The source can be any of the following signals:

- PFI <0..15>
- RTSI <0..7>
- PXI_STAR
- PXIe_DSTAR<A,B>
- Change Detection Event
- Counter *n* Internal Output
- AI Reference Trigger (ai/ReferenceTrigger)
- AO Start Trigger (ao/StartTrigger)
- DO Start Trigger (do/StartTrigger)

The source can also be one of several internal signals on your DAQ device. Refer to *Device Routing in MAX* in the *NI-DAQmx Help* or the *LabVIEW Help* for more information.

You can also specify whether the measurement acquisition stops on the rising or falling edge or falling edge of DI Reference Trigger.

Using an Analog Source

When you use an analog trigger source, the acquisition stops on the first rising edge of the Analog Comparison Event signal.

Routing DI Reference Trigger Signal to an Output Terminal

You can route DI Reference Trigger out to any PFI <0..15>, RTSI <0..7>, PXI_Trig <0..7>, or PXIe_DSTAR terminal. All PFI terminals are configured as inputs by default.

DI Pause Trigger Signal

You can use the DI Pause Trigger (di/PauseTrigger) signal to pause and resume a measurement acquisition. The internal sample clock pauses while the external trigger signal is active and resumes when the signal is inactive. You can program the active level of the pause trigger to be high or low, as shown in Figure 6-6. In the figure, T represents the period, and A represents the unknown time between the clock pulse and the posttrigger.

Figure 6-6. Halt (Internal Clock) and Free Running (External Clock)

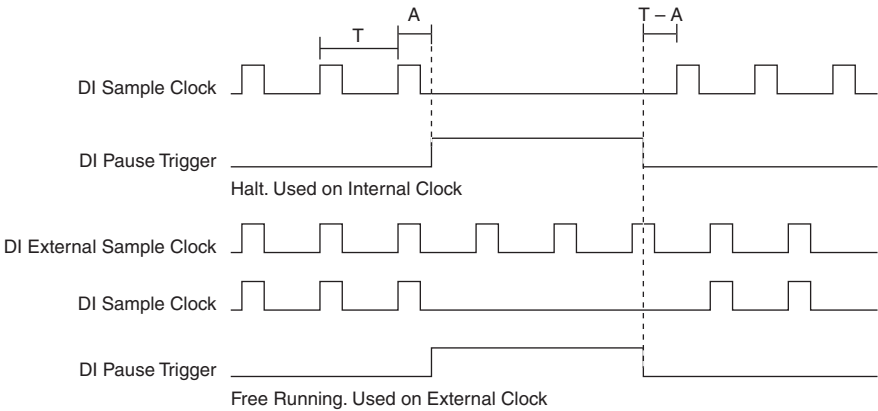

Using a Digital Source

To use DI Pause Trigger, specify a source and a polarity. The source can be any of the following signals:

- PFI <0..15>
- RTSI <0..7>
- PXI_STAR
- PXIe_DSTAR<A,B>
- Counter n Internal Output
- Counter n Gate
- AI Pause Trigger (ai/PauseTrigger)
- AO Pause Trigger (ao/PauseTrigger)
- DO Pause Trigger (do/PauseTrigger)

The source can also be one of several other internal signals on your DAQ device. Refer to *Device Routing in MAX* in the *NI-DAQmx Help* or the *LabVIEW Help* for more information.

Using an Analog Source

When you use an analog trigger source, the internal sample clock pauses when the Analog Comparison Event signal is low and resumes when the signal goes high (or vice versa).

Routing DI Pause Trigger Signal to an Output Terminal

You can route DI Pause Trigger out to any RTSI <0..7>, PFI <0..15>, PXI_STAR, or PXIe_DSTARC terminal.



Note Pause triggers are only sensitive to the level of the source, not the edge.

Digital Output Data Generation Methods

When performing a digital waveform operation, you either can perform software-timed or hardware-timed generations.

Software-Timed Generations

With a software-timed generation, software controls the rate at which data is generated. Software sends a separate command to the hardware to initiate each update. In NI-DAQmx, software-timed generations are referred to as on-demand timing. Software-timed generations are also referred to as immediate or static operations. They are typically used for writing a single value out, such as a constant digital value.

Hardware-Timed Generations

With a hardware-timed generation, a digital hardware signal controls the rate of the generation. This signal can be generated internally on your device or provided externally.

Hardware-timed generations have several advantages over software-timed generations:

- The time between samples can be much shorter.
- The timing between samples can be deterministic.
- Hardware-timed acquisitions can use hardware triggering.

Hardware-timed operations can be buffered or hardware-timed single point (HWTSP). A buffer is a temporary storage in computer memory for to-be-transferred samples.

- **Hardware-timed single point (HWTSP)**—Typically, HWTSP operations are used to write single samples at known time intervals. While buffered operations are optimized for high throughput, HWTSP operations are optimized for low latency and low jitter. In addition, HWTSP can notify software if it falls behind hardware. These features make HWTSP ideal for real time control applications. HWTSP operations, in conjunction with the wait for next sample clock function, provide tight synchronization between the software layer and the hardware layer. Refer to the *NI-DAQmx Hardware-Timed Single Point Lateness Checking* document for more information. To access this document, go to ni.com/info and enter the Info Code `daqhwtsp`.



Note (NI USB-634x/635x/636x Devices) USB X Series devices do not support hardware-timed single point (HWTSP) operations.

- **Buffered**—In a buffered generation, data is moved from a PC buffer to the DAQ device's onboard FIFO using DMA before it is written to the output lines one sample at a time. Buffered generation typically allow for much faster transfer rates than non-buffered acquisitions because data is moved in large blocks, rather than one point at a time. One property of buffered I/O operations is the sample mode. The sample mode can be either finite or continuous:
 - Finite sample mode generation refers to the generation of a specific, predetermined number of data samples. Once the specified number of samples has been written out, the generation stops.
 - Continuous generation refers to the generation of an unspecified number of samples. Instead of generating a set number of data samples and stopping, a continuous generation continues until you stop the operation. There are several different methods of continuous generation that control what data is written. These methods are regeneration, FIFO regeneration and non-regeneration modes:
 - Regeneration is the repetition of the data that is already in the buffer. Standard regeneration is when data from the PC buffer is continually downloaded to the FIFO to be written out. New data can be written to the PC buffer at any time without disrupting the output. Use the NI-DAQmx write property `regenMode` to allow (or not allow) regeneration. The NI-DAQmx default is to allow regeneration.
 - With non-regeneration, old data is not repeated. New data must be continually written to the buffer. If the program does not write new data to the buffer at a fast enough rate to keep up with the generation, the buffer underflows and causes an error.
 - With FIFO regeneration, the entire buffer is downloaded to the FIFO and regenerated from there. Once the data is downloaded, new data cannot be written to the FIFO. To use FIFO regeneration, the entire buffer must fit within the FIFO size. The advantage of using FIFO regeneration is that it does not require communication with the main host memory once the operation is started, thereby preventing any problems that may occur due to excessive bus traffic. Use the NI-DAQmx `UseOnlyOnBoardMemory` DO channel property to enable or disable FIFO regeneration.

Digital Output Triggering

Digital output supports two different triggering actions:

- Start trigger
- Pause trigger

An analog or digital trigger can initiate these actions. All X Series devices support digital triggering, but some do not support analog triggering. To find your device's triggering options, refer to the device specifications. Refer to the [DO Start Trigger Signal](#) and [DO Pause Trigger Signal](#) sections for more information about these triggering actions.

Digital Waveform Generation

You can generate digital waveforms on the Port 0 DIO lines. The DO waveform generation FIFO stores the digital samples. X Series devices have a DMA controller dedicated to moving data from the system memory to the DO waveform generation FIFO. The DAQ device moves samples from the FIFO to the DIO terminals on each rising or falling edge of a clock signal, DO Sample Clock. You can configure each DIO signal to be an input, a static output, or a digital waveform generation output.

The FIFO supports a retransmit mode. In the retransmit mode, after all the samples in the FIFO have been clocked out, the FIFO begins outputting all of the samples again in the same order. For example, if the FIFO contains five samples, the pattern generated consists of sample #1, #2, #3, #4, #5, #1, #2, #3, #4, #5, #1, and so on.

X Series devices feature the following DO (waveform generation) timing signals:

- *DO Sample Clock Signal**
- *DO Sample Clock Timebase Signal*
- *DO Start Trigger Signal**
- *DO Pause Trigger Signal**

Signals with an * support digital filtering. Refer to the *PFI Filters* section of Chapter 8, *PFI*, for more information.

DO Sample Clock Signal

The device uses the DO Sample Clock (do/SampleClock) signal to update the DO terminals with the next sample from the DO waveform generation FIFO.

You can specify an internal or external source for DO Sample Clock. You can also specify whether the DAC update begins on the rising edge or falling edge of DO Sample Clock. If the DAQ device receives a DO Sample Clock when the FIFO is empty, the DAQ device reports an underflow error to the host software.

Using an Internal Source

One of the following internal signals can drive DO Sample Clock:

- DI Sample Clock (di/SampleClock)
- DO Sample Clock (do/SampleClock)
- AI Sample Clock (ai/SampleClock)
- AI Convert Clock (ai/ConvertClock)
- AO Sample Clock (ao/SampleClock)
- Counter n Sample Clock

- Counter n Internal Output
- Frequency Output
- DI Change Detection output

Several other internal signals can be routed to DO Sample Clock through internal routes. Refer to *Device Routing in MAX* in the *NI-DAQmx Help* or the *LabVIEW Help* for more information.

Using an External Source

Use one of the following external signals as the source of DO Sample Clock:

- PFI <0..15>
- RTSI <0..7>
- PXI_STAR
- PXIe_DSTAR<A,B>
- Analog Comparison Event (an analog trigger)

Routing DO Sample Clock to an Output Terminal

You can route DO Sample Clock (as an active low signal) out to any PFI <0..15>, RTSI <0..7>, or PXIe_DSTARC terminal.

Other Timing Requirements

The DO timing engine on your device internally generates DO Sample Clock unless you select some external source. DO Start Trigger starts the timing engine and either the software or hardware can stop it once a finite generation completes. When using the DO timing engine, you can also specify a configurable delay from DO Start Trigger to the first DO Sample Clock pulse. By default, this delay is two ticks of DO Sample Clock Timebase. Figure 6-7 shows the relationship of DO Sample Clock to DO Start Trigger.

Figure 6-7. DO Sample Clock and DO Start Trigger

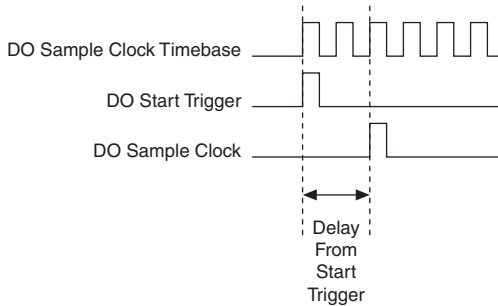

DO Sample Clock Timebase Signal

The DO Sample Clock Timebase (do/SampleClockTimebase) signal is divided down to provide a source for DO Sample Clock. You can route any of the following signals to be the DO Sample Clock Timebase signal:

- 100 MHz Timebase (default)
- 20 MHz Timebase
- 100 kHz Timebase
- PXI_CLK10
- PFI <0..15>
- RTSI <0..7>
- PXI_STAR
- PXIe_DSTAR<A,B>
- Analog Comparison Event (an analog trigger)

DO Sample Clock Timebase is not available as an output on the I/O connector.

You might use DO Sample Clock Timebase if you want to use an external sample clock signal, but need to divide the signal down. If you want to use an external sample clock signal, but do not need to divide the signal, then you should use DO Sample Clock rather than DO Sample Clock Timebase.

DO Start Trigger Signal

Use the DO Start Trigger (do/StartTrigger) signal to initiate a waveform generation. If you do not use triggers, you can begin a generation with a software command.

Retriggerable DO

The DO Start Trigger is configurable as retriggerable. When DO Start Trigger is configured as retriggerable, the timing engine generates the sample clocks for the configured generation in response to each pulse on a DO Start Trigger signal.

The timing engine ignores the DO Start Trigger signal while the clock generation is in progress. After the clock generation is finished, the timing engine waits for another start trigger to begin another clock generation. Figure 6-8 shows a retriggerable DO of four samples.

Figure 6-8. Retriggerable DO

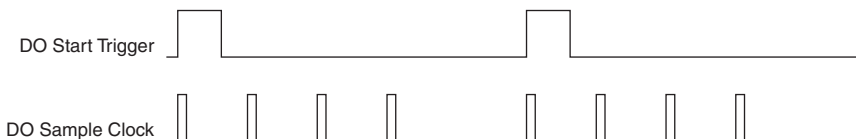

Using a Digital Source

To use DO Start Trigger, specify a source and an edge. The source can be one of the following signals:

- A pulse initiated by host software
- PFI <0..15>
- RTSI <0..7>
- AI Reference Trigger (ai/ReferenceTrigger)
- AI Start Trigger (ai/StartTrigger)
- AO Start Trigger (ao/StartTrigger)
- Counter *n* Internal Output
- DI Start Trigger (di/StartTrigger)
- DI Reference Trigger (di/ReferenceTrigger)
- Change Detection Event
- PXI_STAR
- PXIe_DSTAR<A,B>

The source can also be one of several internal signals on your DAQ device. Refer to *Device Routing in MAX* in the *NI-DAQmx Help* or the *LabVIEW Help* for more information.

You can also specify whether the waveform generation begins on the rising edge or falling edge of DO Start Trigger.

Using an Analog Source

When you use an analog trigger source, the waveform generation begins on the first rising or falling edge of the Analog Comparison Event signal. Refer to the [Triggering with an Analog Source](#) section of Chapter 11, [Triggering](#), for more information.

Routing DO Start Trigger Signal to an Output Terminal

You can route DO Start Trigger out to any PFI <0..15>, RTSI <0..7>, or PXIe_DSTARC terminal.

The output is an active high pulse. PFI terminals are configured as inputs by default.

DO Pause Trigger Signal

Use the DO Pause Trigger (do/PauseTrigger) signal to mask off samples in a DAQ sequence. That is, when DO Pause Trigger is active, no samples occur.

DO Pause Trigger does not stop a sample that is in progress. The pause does not take effect until the beginning of the next sample.

When you generate digital output signals, the generation pauses as soon as the pause trigger is asserted. If the source of your sample clock is the onboard clock, the generation resumes as soon as the pause trigger is deasserted, as shown in Figure 6-9.

Figure 6-9. DO Pause Trigger with the Onboard Clock Source

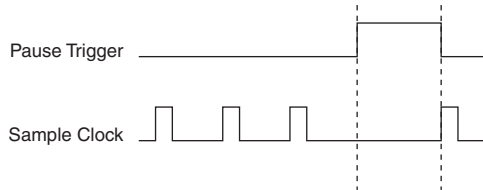

If you are using any signal other than the onboard clock as the source of your sample clock, the generation resumes as soon as the pause trigger is deasserted and another edge of the sample clock is received, as shown in Figure 6-10.

Figure 6-10. DO Pause Trigger with Other Signal Source

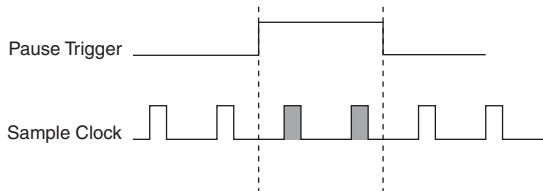

Using a Digital Source

To use DO Pause Trigger, specify a source and a polarity. The source can be one of the following signals:

- PFI <0..15>
- RTSI <0..7>
- PXI_STAR
- PXIe_DSTAR<A,B>
- Counter *n* Internal Output
- Counter *n* Gate
- AI Pause Trigger (ai/PauseTrigger)
- AO Pause Trigger (ao/PauseTrigger)
- DI Pause Trigger (di/PauseTrigger)

The source can also be one of several other internal signals on your DAQ device. Refer to *Device Routing in MAX* in the *NI-DAQmx Help* or the *LabVIEW Help* for more information.

You can also specify whether the samples are paused when DO Pause Trigger is at a logic high or low level.

Using an Analog Source

When you use an analog trigger source, the samples are paused when the Analog Comparison Event signal is at a high level. Refer to the [Triggering with an Analog Source](#) section of Chapter 11, [Triggering](#), for more information.

Routing DO Pause Trigger Signal to an Output Terminal

You can route DO Pause Trigger out to any RTSI <0..7>, PFI <0..15>, or PXIe_DSTARC terminal.

I/O Protection

Each DIO and PFI signal is protected against overvoltage, undervoltage, and overcurrent conditions as well as ESD events. However, you should avoid these fault conditions by following these guidelines:

- If you configure a PFI or DIO line as an output, do not connect it to any external signal source, ground, or power supply.
- If you configure a PFI or DIO line as an output, understand the current requirements of the load connected to these signals. Do not exceed the specified current output limits of the DAQ device. NI has several signal conditioning solutions for digital applications requiring high current drive.
- If you configure a PFI or DIO line as an input, do not drive the line with voltages outside of its normal operating range. The PFI or DIO lines have a smaller operating range than the AI signals.
- Treat the DAQ device as you would treat any static sensitive device. Always properly ground yourself and the equipment when handling the DAQ device or connecting to it.

Programmable Power-Up States

At system startup and reset, the hardware sets all PFI and DIO lines to high-impedance inputs by default. The DAQ device does not drive the signal high or low. Each line has a weak pull-down resistor connected to it, as described in the device specifications.

NI-DAQmx supports programmable power-up states for PFI and DIO lines. Software can program any value at power up to the P0, P1, or P2 lines. The PFI and DIO lines can be set as:

- A high-impedance input with a weak pull-down resistor (default)
- An output driving a 0
- An output driving a 1

Refer to the *NI-DAQmx Help* or the *LabVIEW Help* for more information about setting power-up states in NI-DAQmx or MAX.



Note When using your X Series device to control an SCXI chassis, DIO lines 0, 1, 2, and 4 are used as communication lines and must be left to power-up in the default high-impedance state to avoid potential damage to these signals.

DI Change Detection

You can configure the DAQ device to detect changes on all 32 digital input lines (P0, P1, and P2) and all 16 PFI lines. Figure 6-11 shows a block diagram of the DIO change detection circuitry.

Figure 6-11. DI Change Detection

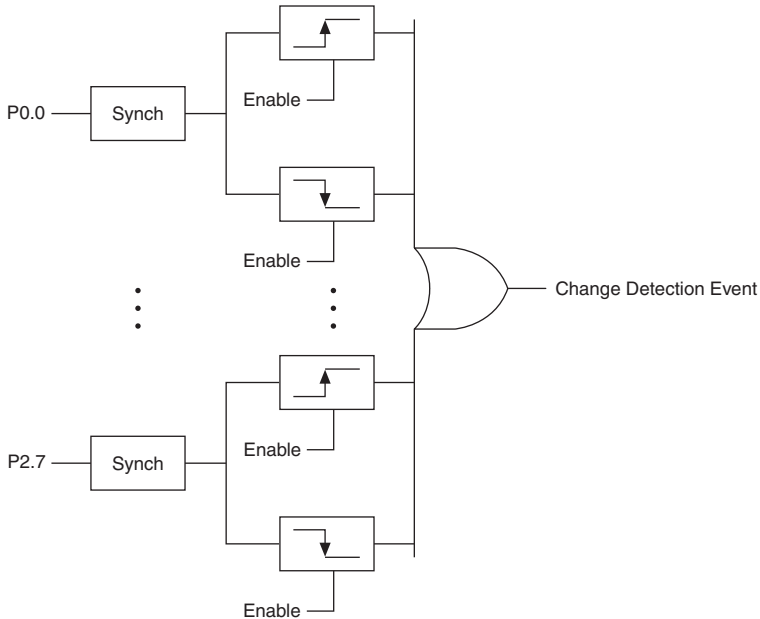

You can enable the DIO change detection circuitry to detect rising edges, falling edges, or either edge individually on each DIO line. The DAQ devices synchronize each DI signal to the 100 MHz Timebase, and then sends the signal to the change detectors. The circuitry ORs the output of all enabled change detectors from every DI signal. The result of this OR is the Change Detection Event signal.

Change detection performs bus correlation by considering all changes within a 50 ns window one change detection event, which keeps signals on the same bus synchronized in samples and prevents overruns.

The Change Detection Event signal can do the following:

- Drive any RTSI <0..7>, PFI <0..15>, or PXI_STAR signal
- Drive the DO Sample Clock or DI Sample Clock
- Generate an interrupt

The Change Detection Event signal can also be used to detect changes on digital output events.

DI Change Detection Applications

The DIO change detection circuitry can interrupt a user program when one of several DIO signals changes state.

You can also use the output of the DIO change detection circuitry to trigger a DI or counter acquisition on the logical OR of several digital signals. To trigger on a single digital signal, refer to the *Triggering with a Digital Source* section of Chapter 11, *Triggering*. By routing the Change Detection Event signal to a counter, you can also capture the relative time between bus changes.

You can also use the Change Detection Event signal to trigger DO or counter generations.

Digital Filtering

You can enable a programmable debouncing filter on each digital line on Port 0. When the filters are enabled, your device samples the input on each rising edge of a filter clock. X Series devices divide down the onboard 100 MHz or 100 kHz clocks to generate the filter clock. The following is an example of low-to-high transitions of the input signal. High-to-low transitions work similarly.

Assume that an input terminal has been low for a long time. The input terminal then changes from low-to-high, but glitches several times. When the filter clock has sampled the signal high on two consecutive edges and the signal remained stable in between, the low-to-high transition is propagated to the rest of the circuit.

Table 6-1. Filters

Filter Setting	Filter Clock	Pulse Width Guaranteed to Pass Filter	Pulse Width Guaranteed to Not Pass Filter
Short	12.5 MHz	160 ns	80 ns
Medium	195.3125 kHz	10.24 μs	5.12 μs
High	390.625 Hz	5.12 ms	2.56 ms
None	—	—	—

The filter setting for each input can be configured independently. On power up, the filters are disabled. Figure 6-12 shows an example of a low-to-high transition on an input.

Figure 6-12. Input Low-to-High Transition

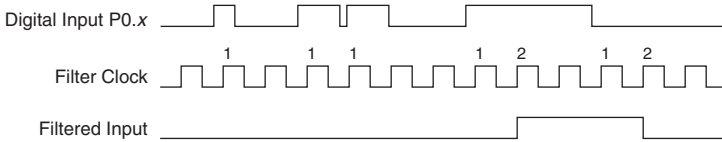

When multiple lines are configured with the same filter settings they are considered a bus. There are two filtering modes for use with multiple lines: line filtering and bus filtering. With line filtering, each line transitions independently of the other lines in the bus and acts like the behavior described above. With bus filtering, if any one line in the bus has jitter then all lines in the bus hold the state until the bus becomes stable. However, each individual line only waits one extra filter tick before changing, which prevents a noisy line from holding a valid transition indefinitely. With bus mode if all the bus line transitions become stable in less than one filter clock period and the bus period is more than two filter clock periods, then all the bus lines are guaranteed to be correlated at the output of the filter.

The behavior for each transition can be thought of as a state machine. If a line transitions and stays high for two consecutive filter clock edges, then one of two options occurs:

- **Case 1**—If no transitions have occurred on the other lines, the transition propagates on the second filtered clock edge, as shown in Figure 6-13.

Figure 6-13. Case 1

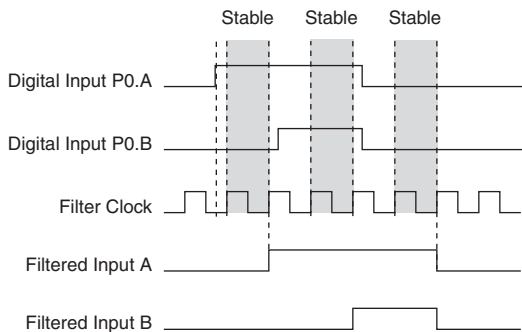

- **Case 2**—If an additional line on the bus also has a transition during the filter clock period, the change is not propagated until the next filter clock edge, as shown in Figure 6-14.

Figure 6-14. Case 2

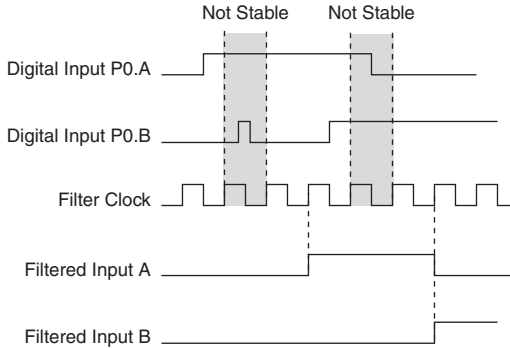
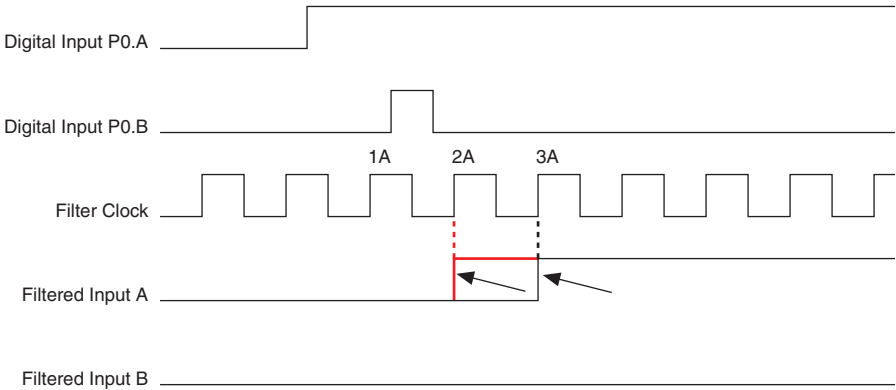

Figure 6-15 illustrates the difference between line and bus filtering.

Figure 6-15. Line and Bus Filtering



- 2A With line filtering, filtered input A would ignore the glitch on digital input P0.B and transition after two filter clocks.
- 3A Filtered input A goes high when sampled high for two consecutive filter clocks and transitions on the next filter edge because digital input P0.B glitches.

Watchdog Timer

The watchdog timer is a software-configurable feature used to set critical outputs to safe states in the event of a software failure, a system crash, or any other loss of communication between the application and the X Series device.



Note The NI-DAQmx Watchdog feature is meant to protect a system from software errors and hangs. In the case of a PXI system with remote control through MXI, a lost MXI connection could result in unexpected Watchdog behavior and therefore improperly implemented Watchdog states.

When the watchdog timer is enabled, if the X Series device does not receive a watchdog reset software command within the time specified for the watchdog timer, the outputs go to a user-defined safe state and remain in that state until the watchdog timer is disarmed by the application and new values are written, the device is reset, or the computer is restarted. The expiration signal that indicates an expired watchdog will continue to assert until the watchdog is disarmed. After the watchdog timer expires, the device ignores any digital writes until the watchdog timer is disarmed.



Note When the watchdog timer is enabled and the computer enters a fault condition, ports that are set to tri-state remain tri-stated and do not go to user-defined safe states.

You can set the watchdog timer timeout period to specify the amount of time that must elapse before the watchdog timer expires. The counter on the watchdog timer is configurable up to $(2^{32} - 1) \times 8$ ns (approximately 34 seconds) before it expires. A watchdog timer can be set for all DIO and PFI lines.

Connecting Digital I/O Signals

The DIO signals, P0.<0..31>, P1.<0..7>, and P2.<0..7> are referenced to D GND. You can individually program each line as an input or output. Figure 6-16 shows P1.<0..3> configured for digital input and P1.<4..7> configured for digital output. Figure 6-16 shows the switch receiving TTL signals and sensing external device states and shows the LED sending TTL signals and driving external devices.

Figure 6-16. Digital I/O Connections

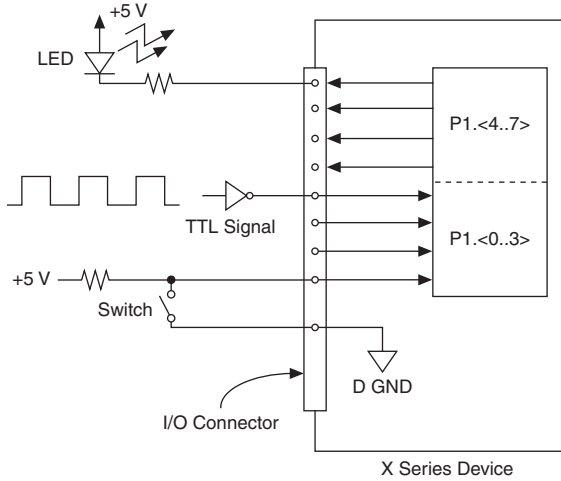

Caution Exceeding the maximum input voltage ratings, which are listed in each X Series device specifications, can damage the DAQ device and the computer. NI is *not* liable for any damage resulting from such signal connections.

Getting Started with DIO Applications in Software

You can use the X Series device in the following digital I/O applications:

- Static digital input
- Static digital output
- Digital waveform generation
- Digital waveform acquisition
- DI change detection



Note For more information about programming digital I/O applications and triggers in software, refer to the *NI-DAQmx Help* or the *LabVIEW Help*.

X Series devices use the NI-DAQmx driver. NI-DAQmx includes a collection of programming examples to help you get started developing an application. You can modify example code and save it in an application. You can use examples to develop a new application or add example code to an existing application.

To locate LabVIEW, LabWindows/CVI, Measurement Studio, Visual Basic, and ANSI C examples, refer to the document, *Where Are NI-DAQmx Examples Installed in Windows?*, by going to ni.com/info and entering the Info Code `daqmxexp`.

For additional examples, refer to ni.com/examples.

Counters

X Series devices have four general-purpose 32-bit counter/timers and one frequency generator. The general-purpose counter/timers can be used for many measurement and pulse generation applications. Figure 7-1 shows the X Series Counter 0 and the frequency generator. All four counters on X Series devices are identical.

Figure 7-1. X Series Counter 0 and Frequency Generator

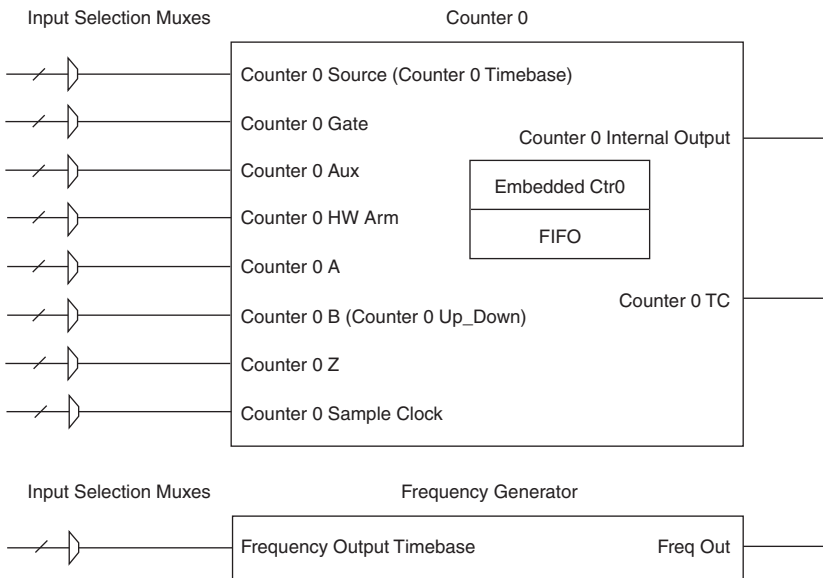

Counters have eight input signals, although in most applications only a few inputs are used.

For information about connecting counter signals, refer to the [Default Counter/Timer Pins](#) section.

Each counter has a FIFO that can be used for buffered acquisition and generation. Each counter also contains an embedded counter (Embedded Ctr n) for use in what are traditionally two-counter measurements and generations. The embedded counters cannot be programmed independent of the main counter; signals from the embedded counters are not routable.

Counter Timing Engine

Unlike analog input, analog output, digital input, and digital output, X Series counters do not have the ability to divide down a timebase to produce an internal counter sample clock. For sample clocked operations, an external signal must be provided to supply a clock source. The source can be any of the following signals:

- AI Sample Clock
- AI Start Trigger
- AI Reference Trigger
- AO Sample Clock
- DI Sample Clock
- DI Start Trigger
- DO Sample Clock
- CTR *n* Internal Output
- Freq Out
- PFI <0..15>
- PXI_Trig <0..7>
- PXIe_DSTAR<A,B>
- Change Detection Event
- Analog Comparison Event

Not all timed counter operations require a sample clock. For example, a simple buffered pulse width measurement latches in data on each edge of a pulse. For this measurement, the measured signal determines when data is latched in. These operations are referred to as implicit timed operations. However, many of the same measurements can be clocked at an interval with a sample clock. These are referred to as sample clocked operations. Table 7-1 shows the different options for the different measurements.



Note All hardware-timed single point (HWTSP) operations are sample clocked.

Table 7-1. Counter Timing Measurements

Measurement	Implicit Timing Support	Sample Clocked Timing Support
Buffered Edge Count	No	Yes
Buffered Pulse Width	Yes	Yes
Buffered Pulse	Yes	Yes
Buffered Semi-Period	Yes	No

Table 7-1. Counter Timing Measurements (Continued)

Measurement	Implicit Timing Support	Sample Clocked Timing Support
Buffered Frequency	Yes	Yes
Buffered Period	Yes	Yes
Buffered Position	No	Yes
Buffered Two-Signal Edge Separation	Yes	Yes

Counter Input Applications

The following sections list the various counter input applications available on X Series devices:

- [Counting Edges](#)
- [Pulse-Width Measurement](#)
- [Pulse Measurement](#)
- [Semi-Period Measurement](#)
- [Frequency Measurement](#)
- [Period Measurement](#)
- [Position Measurement](#)
- [Two-Signal Edge-Separation Measurement](#)

Counting Edges

In edge counting applications, the counter counts edges on its Source after the counter is armed. You can configure the counter to count rising or falling edges on its Source input. You can also control the direction of counting (up or down), as described in the [Controlling the Direction of Counting](#) section. The counter values can be read on demand or with a sample clock.

Refer to the following sections for more information about X Series edge counting options:

- [Single Point \(On-Demand\) Edge Counting](#)
- [Buffered \(Sample Clock\) Edge Counting](#)

Single Point (On-Demand) Edge Counting

With single point (on-demand) edge counting, the counter counts the number of edges on the Source input after the counter is armed. On-demand refers to the fact that software can read the counter contents at any time without disturbing the counting process. Figure 7-2 shows an example of single point edge counting.

Figure 7-2. Single Point (On-Demand) Edge Counting

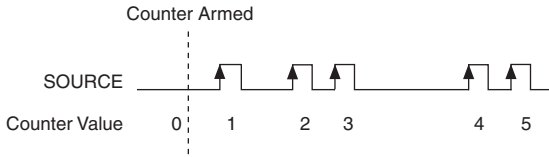

You can also use a pause trigger to pause (or gate) the counter. When the pause trigger is active, the counter ignores edges on its Source input. When the pause trigger is inactive, the counter counts edges normally.

You can route the pause trigger to the Gate input of the counter. You can configure the counter to pause counting when the pause trigger is high or when it is low. Figure 7-3 shows an example of on-demand edge counting with a pause trigger.

Figure 7-3. Single Point (On-Demand) Edge Counting with Pause Trigger

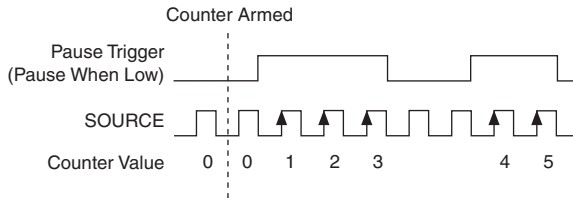

Buffered (Sample Clock) Edge Counting

With buffered edge counting (edge counting using a sample clock), the counter counts the number of edges on the Source input after the counter is armed. The value of the counter is sampled on each active edge of a sample clock and stored in the FIFO. A DMA controller transfers the sampled values to host memory.

The count values returned are the cumulative counts since the counter armed event. That is, the sample clock does not reset the counter.

You can configure the counter to sample on the rising or falling edge of the sample clock.

Figure 7-4 shows an example of buffered edge counting. Notice that counting begins when the counter is armed, which occurs before the first active edge on Sample Clock.

Figure 7-4. Buffered (Sample Clock) Edge Counting

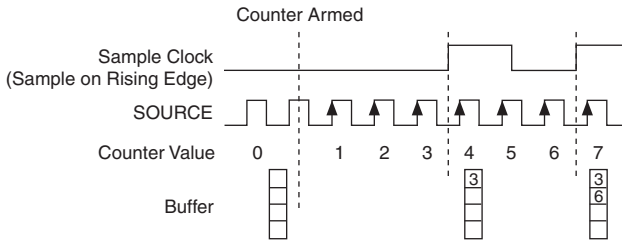

Controlling the Direction of Counting

In edge counting applications, the counter can count up or down. You can configure the counter to do the following:

- Always count up
- Always count down
- Count up when the Counter 0 B input is high; count down when it is low

For information about connecting counter signals, refer to the [Default Counter/Timer Pins](#) section.

Pulse-Width Measurement

In pulse-width measurements, the counter measures the width of a pulse on its Gate input signal. You can configure the counter to measure the width of high pulses or low pulses on the Gate signal.

You can route an internal or external periodic clock signal (with a known period) to the Source input of the counter. The counter counts the number of rising (or falling) edges on the Source signal while the pulse on the Gate signal is active.

You can calculate the pulse width by multiplying the period of the Source signal by the number of edges returned by the counter.

A pulse-width measurement is accurate even if the counter is armed while a pulse train is in progress. If a counter is armed while the pulse is in the active state, it waits for the next transition to the active state to begin the measurement.

Refer to the following sections for more information about X Series pulse-width measurement options:

- [Single Pulse-Width Measurement](#)
- [Implicit Buffered Pulse-Width Measurement](#)
- [Sample Clocked Buffered Pulse-Width Measurement](#)
- [Hardware-Timed Single Point Pulse-Width Measurement](#)

Single Pulse-Width Measurement

With single pulse-width measurement, the counter counts the number of edges on the Source input while the Gate input remains active. When the Gate input goes inactive, the counter stores the count in the FIFO and ignores other edges on the Gate and Source inputs. Software then reads the stored count.

Figure 7-5 shows an example of a single pulse-width measurement.

Figure 7-5. Single Pulse-Width Measurement

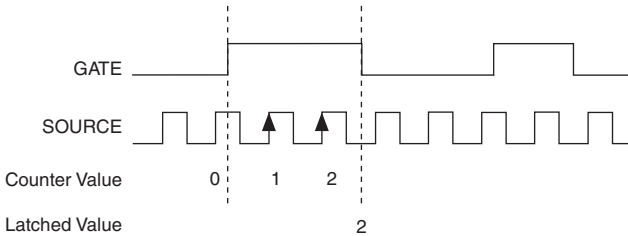

Implicit Buffered Pulse-Width Measurement

An implicit buffered pulse-width measurement is similar to single pulse-width measurement, but buffered pulse-width measurement takes measurements over multiple pulses.

The counter counts the number of edges on the Source input while the Gate input remains active. On each trailing edge of the Gate signal, the counter stores the count in the counter FIFO. A DMA controller transfers the stored values to host memory.

Figure 7-6 shows an example of an implicit buffered pulse-width measurement.

Figure 7-6. Implicit Buffered Pulse-Width Measurement

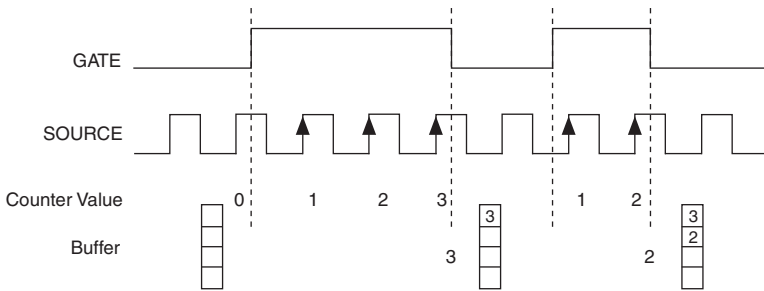

Sample Clocked Buffered Pulse-Width Measurement

A Sample Clocked Buffered pulse-width measurement is similar to single pulse-width measurement, but buffered pulse-width measurement takes measurements over multiple pulses correlated to a sample clock.

The counter counts the number of edges on the Source input while the Gate input remains active. On each sample clock edge, the counter stores the count in the FIFO of the last pulse width to complete. A DMA controller transfers the stored values to host memory.

Figure 7-7 shows an example of a sample clocked buffered pulse-width measurement.

Figure 7-7. Sample Clocked Buffered Pulse-Width Measurement

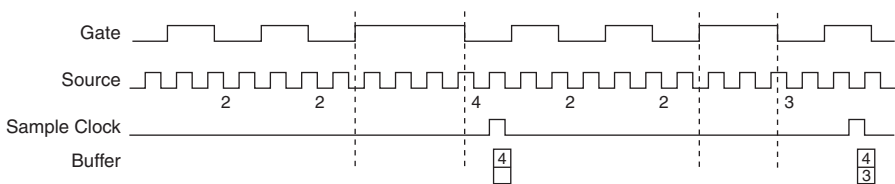

Hardware-Timed Single Point Pulse-Width Measurement

A hardware-timed single point (HWTSP) pulse-width measurement has the same behavior as a sample clocked buffered pulse-width measurement.



Note If a pulse does not occur between sample clocks, an overrun error occurs.



Note (NI USB-634x/635x/636x Devices) USB X Series devices do not support hardware-timed single point (HWTSP) operations.

For information about connecting counter signals, refer to the [Default Counter/Timer Pins](#) section.

Pulse Measurement

In pulse measurements, the counter measures the high and low time of a pulse on its Gate input signal after the counter is armed. A pulse is defined in terms of its high and low time, high and low ticks or frequency and duty cycle, which is similar to the pulse-width measurement, except that the inactive pulse is measured as well.

You can route an internal or external periodic clock signal (with a known period) to the Source input of the counter. The counter counts the number of rising (or falling) edges occurring on the Source input between two edges of the Gate signal.

You can calculate the high and low time of the Gate input by multiplying the period of the Source signal by the number of edges returned by the counter.

Refer to the following sections for more information about X Series pulse measurement options:

- [Single Pulse Measurement](#)
- [Implicit Buffered Pulse Measurement](#)
- [Sample Clocked Buffered Pulse Measurement](#)
- [Hardware-Timed Single Point Pulse Measurement](#)

Single Pulse Measurement

Single (on-demand) pulse measurement is equivalent to two single pulse-width measurements on the high (H) and low (L) ticks of a pulse, as shown in Figure 7-8.

Figure 7-8. Single (On-Demand) Pulse Measurement

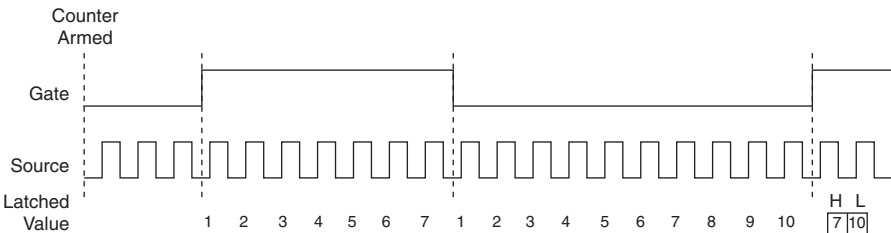

Implicit Buffered Pulse Measurement

In an implicit buffered pulse measurement, on each edge of the Gate signal, the counter stores the count in the FIFO. A DMA controller transfers the stored values to host memory.

The counter begins counting when it is armed. The arm usually occurs between edges on the Gate input, but the counting does not start until the desired edge. You can select whether to read the high pulse or low pulse first using the StartingEdge property in NI-DAQmx.

Figure 7-9 shows an example of an implicit buffered pulse measurement.

Figure 7-9. Implicit Buffered Pulse Measurement

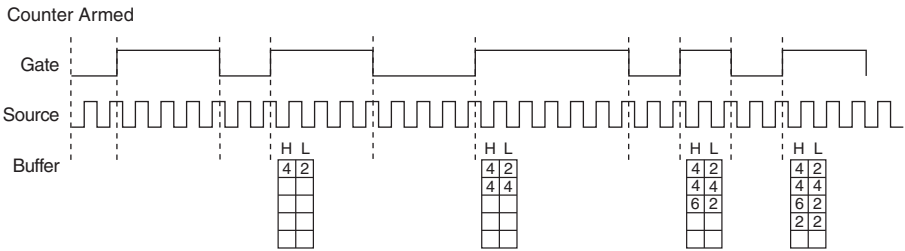

Sample Clocked Buffered Pulse Measurement

A sample clocked buffered pulse measurement is similar to single pulse measurement, but a buffered pulse measurement takes measurements over multiple pulses correlated to a sample clock.

The counter performs a pulse measurement on the Gate. On each sample clock edge, the counter stores the high and low ticks in the FIFO of the last pulse to complete. A DMA controller transfers the stored values to host memory.

Figure 7-10 shows an example of a sample clocked buffered pulse measurement.

Figure 7-10. Sample Clocked Buffered Pulse Measurement

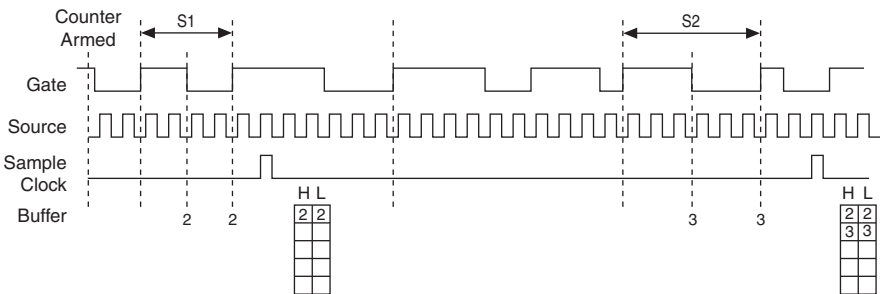

Hardware-Timed Single Point Pulse Measurement

A hardware-timed single point (HWTSP) pulse measurement has the same behavior as a sample clocked buffered pulse measurement.



Note If a pulse does not occur between sample clocks, an overrun error occurs.



Note (NI USB-634x/635x/636x Devices) USB X Series devices do not support hardware-timed single point (HWTSP) operations.

For information about connecting counter signals, refer to the [Default Counter/Timer Pins](#) section.

Pulse versus Semi-Period Measurements

In hardware, pulse measurement and semi-period are the same measurement. Both measure the high and low times of a pulse. The functional difference between the two measurements is how the data is returned. In a semi-period measurement, each high or low time is considered one point of data and returned in units of seconds or ticks. In a pulse measurement, each pair of high and low times is considered one point of data and returned as a paired sample in units of frequency and duty cycle, high and low time or high and low ticks. When reading data, 10 points in a semi-period measurement gets an array of five high times and five low times. When you read 10 points in a pulse measurement, you get an array of 10 pairs of high and low times.

Also, pulse measurements support sample clock timing while semi-period measurements do not.

Semi-Period Measurement

In semi-period measurements, the counter measures a semi-period on its Gate input signal after the counter is armed. A semi-period is the time between any two consecutive edges on the Gate input.

You can route an internal or external periodic clock signal (with a known period) to the Source input of the counter. The counter counts the number of rising (or falling) edges occurring on the Source input between two edges of the Gate signal.

You can calculate the semi-period of the Gate input by multiplying the period of the Source signal by the number of edges returned by the counter.

Refer to the following sections for more information about X Series semi-period measurement options:

- [Single Semi-Period Measurement](#)
- [Implicit Buffered Semi-Period Measurement](#)

Refer to the [Pulse versus Semi-Period Measurements](#) section for information about the differences between semi-period measurement and pulse measurement.

Single Semi-Period Measurement

Single semi-period measurement is equivalent to single pulse-width measurement.

Implicit Buffered Semi-Period Measurement

In implicit buffered semi-period measurement, on each edge of the Gate signal, the counter stores the count in the FIFO. A DMA controller transfers the stored values to host memory.

The counter begins counting when it is armed. The arm usually occurs between edges on the Gate input. You can select whether to read the first active low or active high semi period using the `CI.SemiPeriod.StartingEdge` property in NI-DAQmx.

Figure 7-11 shows an example of an implicit buffered semi-period measurement.

Figure 7-11. Implicit Buffered Semi-Period Measurement

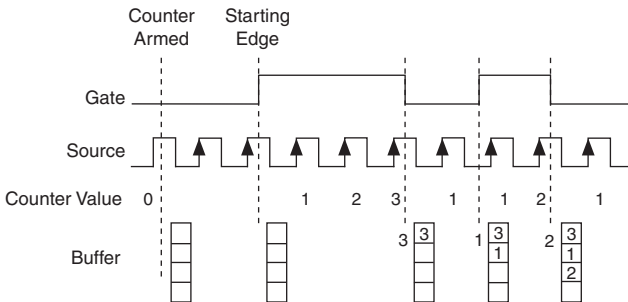

For information about connecting counter signals, refer to the [Default Counter/Timer Pins](#) section.

Frequency Measurement

You can use the counters to measure frequency in several different ways. Refer to the following sections for information about X Series frequency measurement options:

- [Low Frequency with One Counter](#)
- [High Frequency with Two Counters](#)
- [Large Range of Frequencies with Two Counters](#)
- [Sample Clocked Buffered Frequency Measurement](#)
- [Hardware-Timed Single Point Frequency Measurement](#)

Low Frequency with One Counter

For low frequency measurements with one counter, you measure one period of your signal using a known timebase.

You can route the signal to measure (f_x) to the Gate of a counter. You can route a known timebase (f_k) to the Source of the counter. The known timebase can be an onboard timebase, such as 100 MHz Timebase, 20 MHz Timebase, or 100 kHz Timebase, or any other signal with a known rate.

You can configure the counter to measure one period of the gate signal. The frequency of f_x is the inverse of the period. Figure 7-12 illustrates this method.

Figure 7-12. Low Frequency with One Counter

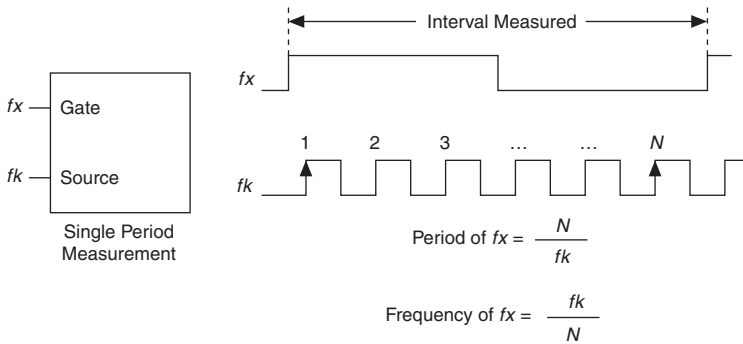

High Frequency with Two Counters

For high frequency measurements with two counters, you measure one pulse of a known width using your signal and derive the frequency of your signal from the result.



Note Counter 0 is always paired with Counter 1. Counter 2 is always paired with Counter 3.

In this method, you route a pulse of known duration (T) to the Gate of a counter. You can generate the pulse using a second counter. You can also generate the pulse externally and connect it to a PFI or RTSI terminal. You only need to use one counter if you generate the pulse externally.

Route the signal to measure (f_x) to the Source of the counter. Configure the counter for a single pulse-width measurement. If you measure the width of pulse T to be N periods of f_x , the frequency of f_x is N/T .

Figure 7-13 illustrates this method. Another option is to measure the width of a known period instead of a known pulse.

Figure 7-13. High Frequency with Two Counters

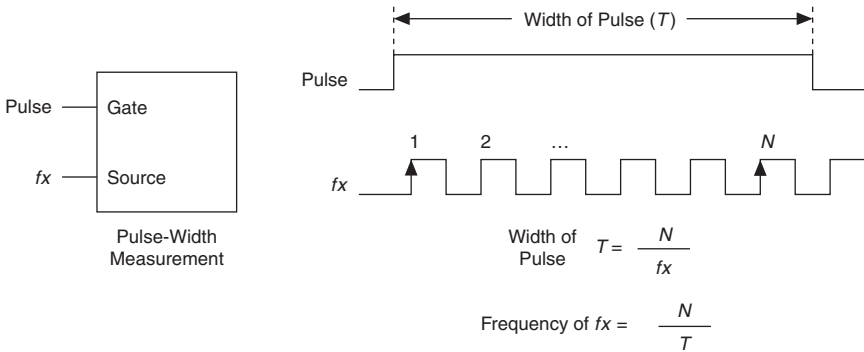

Large Range of Frequencies with Two Counters

By using two counters, you can accurately measure a signal that might be high or low frequency. This technique is called reciprocal frequency measurement. When measuring a large range of frequencies with two counters, you generate a long pulse using the signal to measure. You then measure the long pulse with a known timebase. The X Series device can measure this long pulse more accurately than the faster input signal.



Note Counter 0 is always paired with Counter 1. Counter 2 is always paired with Counter 3.

You can route the signal to measure to the Source input of Counter 0, as shown in Figure 7-14. Assume this signal to measure has frequency f_x . NI-DAQmx automatically configures Counter 0 to generate a single pulse that is the width of N periods of the source input signal.

Figure 7-14. Large Range of Frequencies with Two Counters

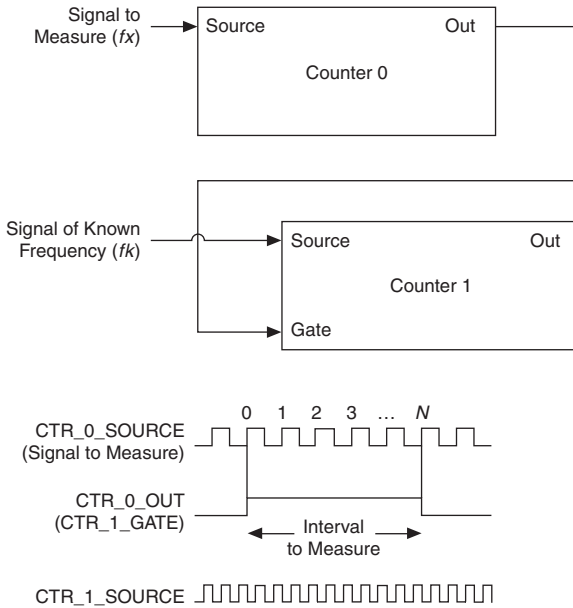

NI-DAQmx then routes the Counter 0 Internal Output signal to the gate of Counter 1. You can then route a signal of known frequency (f_k) as a counter timebase to the Counter 1 Source input. NI-DAQmx configures Counter 1 to perform a single pulse-width measurement. Suppose the result is that the pulse width is J periods of the f_k clock.

From Counter 0, the length of the pulse is N/f_x . From Counter 1, the length of the same pulse is J/f_k . Therefore, the frequency of f_x is given by $f_x = f_k * (N/J)$.

Sample Clocked Buffered Frequency Measurement

Sample clocked buffered point frequency measurements can either be a single frequency measurement or an average between sample clocks. Use `CI.Freq.EnableAveraging` to set the behavior. For buffered frequency, the default is `True`. For hardware-timed single point (HWTSP), the default is `False`.

A sample clocked buffered frequency measurement with `CI.Freq.EnableAveraging` set to `True` uses the embedded counter and a sample clock to perform a frequency measurement. For each sample clock period, the embedded counter counts the signal to measure (f_x) and the primary counter counts the internal time-base of a known frequency (f_k). Suppose T_1 is the number of ticks of the unknown signal counted between sample clocks and T_2 is the number of ticks counted of the known time-base. The frequency measured will be $f_x = f_k * (T_1/T_2)$.

Figure 7-15. Sample Clocked Buffered Frequency Measurement (Averaging)

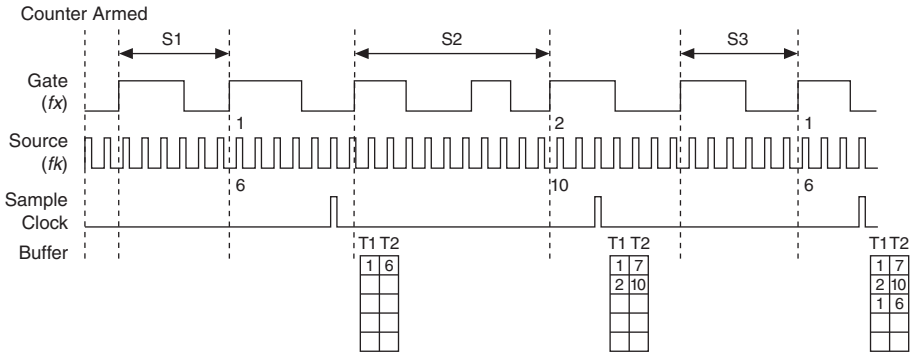

When `CI.Freq.EnableAveraging` is set to `false`, the frequency measurement returns the frequency of the pulse just before the sample clock. This single measurement is a single frequency measurement and is not an average between clocks.

Figure 7-16. Sample Clocked Buffered Frequency Measurement (Non-Averaging)

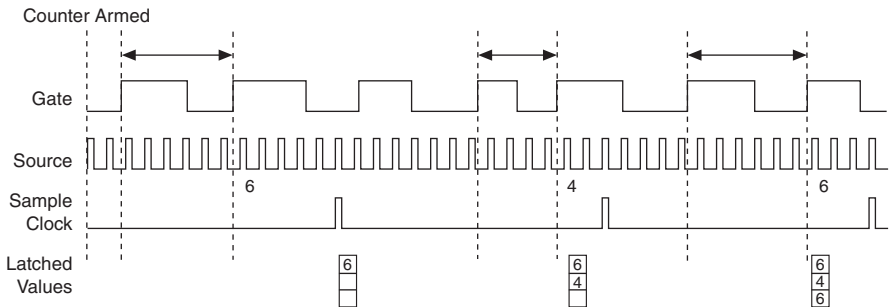

With sample clocked frequency measurements, ensure that the frequency to measure is twice as fast as the sample clock to prevent a measurement overflow.

Hardware-Timed Single Point Frequency Measurement

Hardware-timed single point (HWTSP) frequency measurements can either be a single frequency measurement or an average between sample clocks. Use `CI.Freq.EnableAveraging` to set the behavior. For hardware-timed single point, the default is `False`. Refer to the [Sample Clocked Buffered Frequency Measurement](#) section for more information.

Figure 7-17. Hardware-Timed Single Point Frequency Measurement

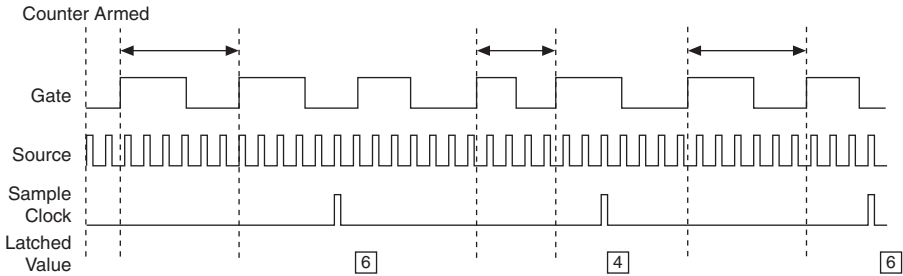

Note (NI USB-634x/635x/636x Devices) USB X Series devices do not support hardware-timed single point (HWTSP) operations.

Choosing a Method for Measuring Frequency

The best method to measure frequency depends on several factors including the expected frequency of the signal to measure, the desired accuracy, how many counters are available, and how long the measurement can take. For all frequency measurement methods, assume the following:

- f_x is the frequency to be measured if no error
- f_k is the known source or gate frequency
- measurement time (T) is the time it takes to measure a single sample
- Divide down (N) is the integer to divide down measured frequency, only used in large range two counters
- f_s is the sample clock rate, only used in sample clocked frequency measurements

Here is how these variables apply to each method, summarized in Table 7-2.

- **One counter**—With one counter measurements, a known timebase is used for the source frequency (f_k). The measurement time is the period of the frequency to be measured, or $1/f_x$.
- **Two counter high frequency**—With the two counter high frequency method, the second counter provides a known measurement time. The gate frequency equals $1/\text{measurement time}$.
- **Two counter large range**—The two counter larger range measurement is the same as a one counter measurement, but now the user has an integer divide down of the signal. An internal timebase is still used for the source frequency (f_k), but the divide down means that the measurement time is the period of the divided down signal, or N/f_x where N is the divide down.
- **Sample clocked**—For sample clocked frequency measurements, a known timebase is counted for the source frequency (f_k). The measurement time is the period of the sample clock (f_s).

Table 7-2. Frequency Measurement Methods

Variable	Sample Clocked	One Counter	Two Counter	
			High Frequency	Large Range
f_k	Known timebase	Known timebase	$\frac{1}{\text{gating period}}$	Known timebase
Measurement time	$\frac{1}{f_s}$	$\frac{1}{f_x}$	gating period	$\frac{N}{f_x}$
Max. frequency error	$f_x \times \frac{f_x}{f_k \times \left[\frac{f_x}{f_s} - 1 \right]}$	$f_x \times \frac{f_x}{f_k - f_x}$	f_k	$f_x \times \frac{f_x}{N \times f_k - f_x}$
Max. error %	$\frac{f_x}{f_k \times \left[\frac{f_x}{f_s} - 1 \right]}$	$\frac{f_x}{f_k - f_x}$	$\frac{f_k}{f_x}$	$\frac{f_x}{N \times f_k - f_x}$
Note: Accuracy equations do not take clock stability into account. Refer to your device specifications for clock stability.				

Which Method Is Best?

This depends on the frequency to be measured, the rate at which you want to monitor the frequency and the accuracy you desire. Take for example, measuring a 50 kHz signal. Assuming that the measurement times for the sample clocked (with averaging) and two counter frequency measurements are configured the same, Table 7-3 summarizes the results.

Table 7-3. 50 kHz Frequency Measurement Methods

Variable	Sample Clocked	One Counter	Two Counter	
			High Frequency	Large Range
f_x	50,000	50,000	50,000	50,000
f_k	100 M	100 M	1,000	100 M
Measurement time (ms)	1	.02	1	1
N	—	—	—	50
Max. frequency error (Hz)	.512	25	1,000	.5
Max. error %	.00102	.05	2	.001

From these results, you can see that while the measurement time for one counter is shorter, the accuracy is best in the sample clocked and two counter large range measurements. For another example, Table 7-4 shows the results for 5 MHz.

Table 7-4. 5 MHz Frequency Measurement Methods

Variable	Sample Clocked	One Counter	Two Counter	
			High Frequency	Large Range
f_x	5 M	5 M	5 M	5 M
f_k	100 M	100 M	1,000	100 M
Measurement time (ms)	1	.0002	1	1
N	—	—	—	5,000
Max. Frequency error (Hz)	50.01	263 k	1,000	50
Max. Error %	.001	5.26	.02	.001

Again the measurement time for the one counter measurement is lowest, but the accuracy is lower. Note that the accuracy and measurement time of the sample clocked and two counter large range are almost the same. The advantage of the sample clocked method is that even when the frequency to measure changes, the measurement time does not and error percentage varies little. For example, if you configured a large range two counter measurement to use a divide down of 50 for a 50 k signal, then you would get the accuracy measurement time and accuracy listed in Table 7-3. But if your signal ramped up to 5 M, then with a divide down of 50, your measurement time is 0.01 ms, but your error is now 0.1%. The error with a sample clocked frequency measurement is not as dependent on the measured frequency so at 50 k and 5 M with a measurement time of 1 ms the error percentage is still close to 0.001%. One of the disadvantages of a sample clocked frequency measurement is that the frequency to be measured must be at least twice the sample clock rate to ensure that a full period of the frequency to be measured occurs between sample clocks.

- Low frequency measurements with one counter is a good method for many applications. However, the accuracy of the measurement decreases as the frequency increases.
- High frequency measurements with two counters is accurate for high frequency signals. However, the accuracy decreases as the frequency of the signal to measure decreases. At very low frequencies, this method may be too inaccurate for your application. Another disadvantage of this method is that it requires two counters (if you cannot provide an external signal of known width). An advantage of high frequency measurements with two counters is that the measurement completes in a known amount of time.
- Measuring a large range of frequencies with two counters measures high and low frequency signals accurately. However, it requires two counters, and it has a variable sample time and variable error % dependent on the input signal.
- Again, the measurement time for the one counter measurement is lowest, but the accuracy is lower. Note that the accuracy and measurement time of the sample clocked and two counter large range are the same. The advantage of the sample clocked method is that even when the frequency to measure changes, the measurement time and error % does not. For example, if you configured a large range two counter measurement to use a divide down of 50 for a 50 kHz signal, then you would get the accuracy measurement time and accuracy listed in table 7-3. But if your signal ramped up to 5 MHz, then with a divide down of 50, your measurement time would be 0.01 ms, but your error would now be 0.1%. The error with a sample clocked frequency measurement is not dependent on the measured frequency so at 50 kHz and 5 MHz with a measurement time of 1 ms the error % will still be 0.001%. One of the disadvantages of a sample clocked frequency measurement is that the frequency to be measured must be at least twice the sample clock rate to ensure that a full period of the frequency to be measured occurs between sample clocks.

Table 7-5 summarizes some of the differences in methods of measuring frequency.

Table 7-5. Frequency Measurement Method Comparison

Method	Number of Counters Used	Number of Measurements Returned	Measures High Frequency Signals Accurately	Measures Low Frequency Signals Accurately
Low frequency with one counter	1	1	Poor	Good
High frequency with two counters	1 or 2	1	Good	Poor
Large range of frequencies with two counters	2	1	Good	Good
Sample clocked (averaged)	1	1	Good	Good

For information about connecting counter signals, refer to the [Default Counter/Timer Pins](#) section.

Period Measurement

In period measurements, the counter measures a period on its Gate input signal after the counter is armed. You can configure the counter to measure the period between two rising edges or two falling edges of the Gate input signal.

You can route an internal or external periodic clock signal (with a known period) to the Source input of the counter. The counter counts the number of rising (or falling) edges occurring on the Source input between the two active edges of the Gate signal.

You can calculate the period of the Gate input by multiplying the period of the Source signal by the number of edges returned by the counter.

Period measurements return the inverse results of frequency measurements. Refer to the [Frequency Measurement](#) section for more information.

Position Measurement

You can use the counters to perform position measurements with quadrature encoders or two-pulse encoders. You can measure angular position with X1, X2, and X4 angular encoders. Linear position can be measured with two-pulse encoders. You can choose to do either a single point (on-demand) position measurement or a buffered (sample clock) position measurement. You must arm a counter to begin position measurements.

Refer to the following sections for more information about the X Series position measurement options:

- [Measurements Using Quadrature Encoders](#)
- [Measurements Using Two Pulse Encoders](#)
- [Buffered \(Sample Clock\) Position Measurement](#)

Measurements Using Quadrature Encoders

The counters can perform measurements of quadrature encoders that use X1, X2, or X4 encoding. A quadrature encoder can have up to three channels—channels A, B, and Z.

- **X1 Encoding**—When channel A leads channel B in a quadrature cycle, the counter increments. When channel B leads channel A in a quadrature cycle, the counter decrements. The amount of increments and decrements per cycle depends on the type of encoding—X1, X2, or X4.

Figure 7-18 shows a quadrature cycle and the resulting increments and decrements for X1 encoding. When channel A leads channel B, the increment occurs on the rising edge of channel A. When channel B leads channel A, the decrement occurs on the falling edge of channel A.

Figure 7-18. X1 Encoding

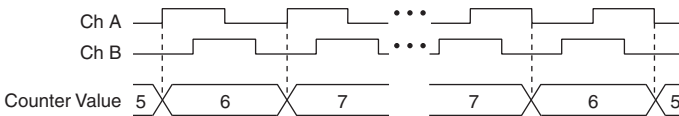

- **X2 Encoding**—The same behavior holds for X2 encoding except the counter increments or decrements on each edge of channel A, depending on which channel leads the other. Each cycle results in two increments or decrements, as shown in Figure 7-19.

Figure 7-19. X2 Encoding

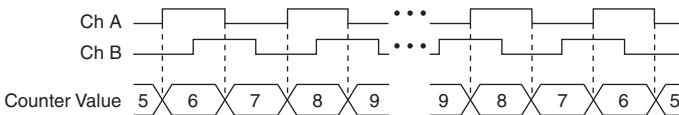

- X4 Encoding**—Similarly, the counter increments or decrements on each edge of channels A and B for X4 encoding. Whether the counter increments or decrements depends on which channel leads the other. Each cycle results in four increments or decrements, as shown in Figure 7-20.

Figure 7-20. X4 Encoding

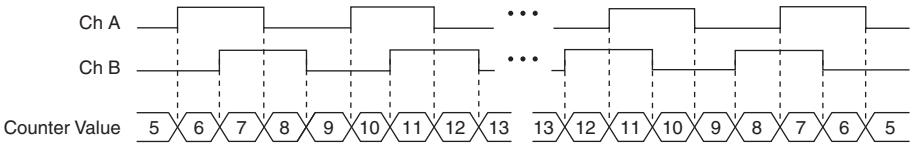

Channel Z Behavior

Some quadrature encoders have a third channel, channel Z, which is also referred to as the index channel. A high level on channel Z causes the counter to be reloaded with a specified value in a specified phase of the quadrature cycle. You can program the counter reload to occur in any one of the four phases in a quadrature cycle.

Channel Z behavior—when it goes high and how long it stays high—differs with quadrature encoder designs. You must refer to the documentation for your quadrature encoder to obtain timing of channel Z with respect to channels A and B. You must then ensure that channel Z is high during at least a portion of the phase you specify for reload. For instance, in Figure 7-21, channel Z is never high when channel A is high and channel B is low. Thus, the reload must occur in some other phase.

In Figure 7-21, the reload phase is when both channel A and channel B are low. The reload occurs when the phase is true and channel Z is high. Incrementing and decrementing takes priority over reloading. Thus, when the channel B goes low to enter the reload phase, the increment occurs first. The reload occurs within one maximum timebase period after the reload phase becomes true. After the reload occurs, the counter continues to count as before. Figure 7-21 illustrates channel Z reload with X4 decoding.

Figure 7-21. Channel Z Reload with X4 Decoding

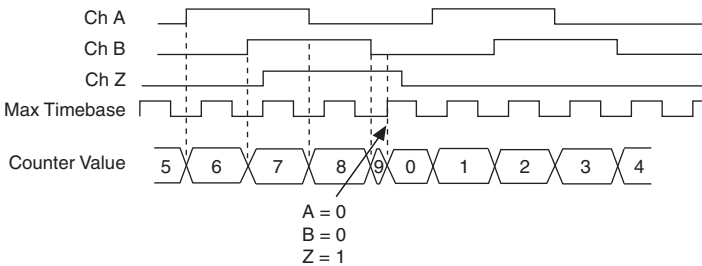

Measurements Using Two Pulse Encoders

The counter supports two pulse encoders that have two channels—channels A and B.

The counter increments on each rising edge of channel A. The counter decrements on each rising edge of channel B, as shown in Figure 7-22.

Figure 7-22. Measurements Using Two Pulse Encoders

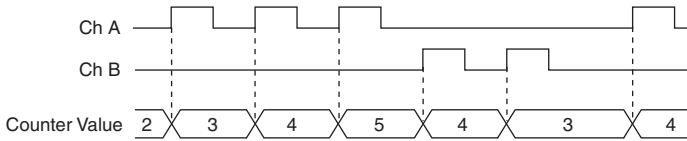

For information about connecting counter signals, refer to the [Default Counter/Timer Pins](#) section.

Buffered (Sample Clock) Position Measurement

With buffered position measurement (position measurement using a sample clock), the counter increments based on the encoding used after the counter is armed. The value of the counter is sampled on each active edge of a sample clock. A DMA controller transfers the sampled values to host memory. The count values returned are the cumulative counts since the counter armed event; that is, the sample clock does not reset the counter. You can route the counter sample clock to the Gate input of the counter. You can configure the counter to sample on the rising or falling edge of the sample clock.

Figure 7-23 shows an example of a buffered X1 position measurement.

Figure 7-23. Buffered Position Measurement

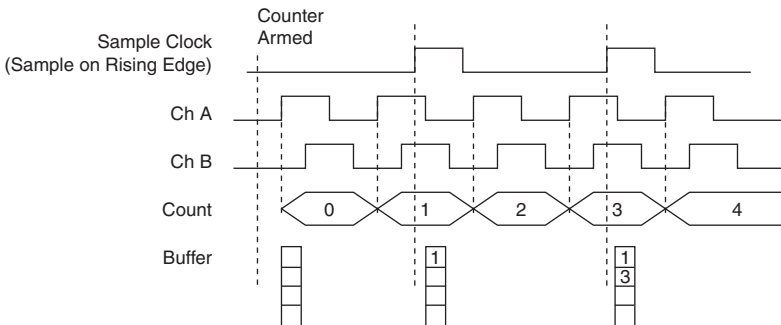

Hardware-Timed Single Point Position Measurement

A hardware-timed single point (HWTSP) position measurement has the same behavior as a buffered (sample clock) position measurement.



Note (NI USB-634x/635x/636x Devices) X Series USB devices do not support hardware-timed single point (HWTSP) operations.

For information about connecting counter signals, refer to the [Default Counter/Timer Pins](#) section.

Two-Signal Edge-Separation Measurement

Two-signal edge-separation measurement is similar to pulse-width measurement, except that there are two measurement signals—Aux and Gate. An active edge on the Aux input starts the counting and an active edge on the Gate input stops the counting. You must arm a counter to begin a two edge separation measurement.

After the counter has been armed and an active edge occurs on the Aux input, the counter counts the number of rising (or falling) edges on the Source. The counter ignores additional edges on the Aux input.

The counter stops counting upon receiving an active edge on the Gate input. The counter stores the count in the FIFO.

You can configure the rising or falling edge of the Aux input to be the active edge. You can configure the rising or falling edge of the Gate input to be the active edge.

Use this measurement type to count events or measure the time that occurs between edges on two signals. This type of measurement is sometimes referred to as start/stop trigger measurement, second gate measurement, or A-to-B measurement.

Refer to the following sections for more information about the X Series edge-separation measurement options:

- [Single Two-Signal Edge-Separation Measurement](#)
- [Implicit Buffered Two-Signal Edge-Separation Measurement](#)
- [Sample Clocked Buffered Two-Signal Separation Measurement](#)
- [Hardware-Timed Single Point Two-Signal Separation Measurement](#)

Single Two-Signal Edge-Separation Measurement

With single two-signal edge-separation measurement, the counter counts the number of rising (or falling) edges on the Source input occurring between an active edge of the Gate signal and an active edge of the Aux signal. The counter then stores the count in the FIFO and ignores other edges on its inputs. Software then reads the stored count.

Figure 7-24 shows an example of a single two-signal edge-separation measurement.

Figure 7-24. Single Two-Signal Edge-Separation Measurement

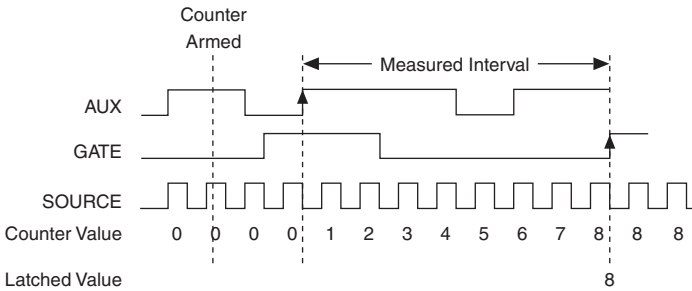

Implicit Buffered Two-Signal Edge-Separation Measurement

Implicit buffered and single two-signal edge-separation measurements are similar, but implicit buffered measurement measures multiple intervals.

The counter counts the number of rising (or falling) edges on the Source input occurring between an active edge of the Gate signal and an active edge of the Aux signal. The counter then stores the count in the FIFO. On the next active edge of the Gate signal, the counter begins another measurement. A DMA controller transfers the stored values to host memory.

Figure 7-25 shows an example of an implicit buffered two-signal edge-separation measurement.

Figure 7-25. Implicit Buffered Two-Signal Edge-Separation Measurement

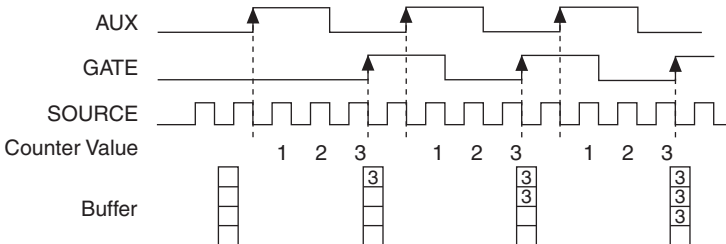

Sample Clocked Buffered Two-Signal Separation Measurement

A sample clocked buffered two-signal separation measurement is similar to single two-signal separation measurement, but buffered two-signal separation measurement takes measurements over multiple intervals correlated to a sample clock. The counter counts the number of rising (or falling) edges on the Source input occurring between an active edge of the Gate signal and an active edge of the Aux signal. The counter then stores the count in the FIFO on a sample clock edge. On the next active edge of the Gate signal, the counter begins another measurement. A DMA controller transfers the stored values to host memory.

Figure 7-26 shows an example of a sample clocked buffered two-signal separation measurement.

Figure 7-26. Sample Clocked Buffered Two-Signal Separation Measurement

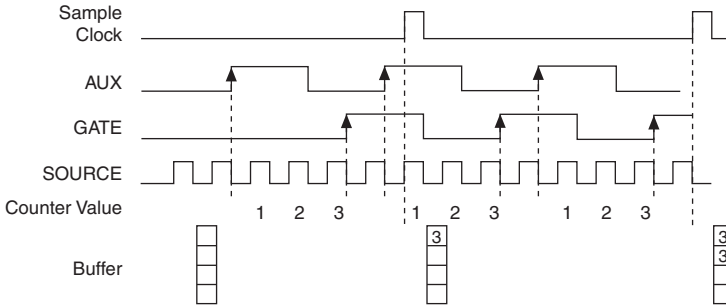

Hardware-Timed Single Point Two-Signal Separation Measurement

A hardware-timed single point (HWTSP) two-signal separation measurement has the same behavior as a sample clocked buffered two-signal separation measurement. Refer to the [Sample Clocked Buffered Two-Signal Separation Measurement](#) section for more information.



Note If an active edge on the Gate and an active edge on the AUX does not occur between sample clocks, an overrun error occurs.



Note (NI USB-63xx Devices) USB X Series devices do not support hardware-timed single point (HWTSP) operations.

For information about connecting counter signals, refer to the [Default Counter/Timer Pins](#) section.

Counter Output Applications

The following sections list the various counter output applications available on X Series devices:

- [Simple Pulse Generation](#)
- [Pulse Train Generation](#)
- [Frequency Generation](#)
- [Frequency Division](#)
- [Pulse Generation for ETS](#)

Simple Pulse Generation

Refer to the following sections for more information about the X Series simple pulse generation options:

- [Single Pulse Generation](#)
- [Single Pulse Generation with Start Trigger](#)

Single Pulse Generation

The counter can output a single pulse. The pulse appears on the Counter n Internal Output signal of the counter.

You can specify a delay from when the counter is armed to the beginning of the pulse. The delay is measured in terms of a number of active edges of the Source input.

You can specify a pulse width. The pulse width is also measured in terms of a number of active edges of the Source input. You can also specify the active edge of the Source input (rising or falling).

Figure 7-27 shows a generation of a pulse with a pulse delay of four and a pulse width of three (using the rising edge of Source).

Figure 7-27. Single Pulse Generation

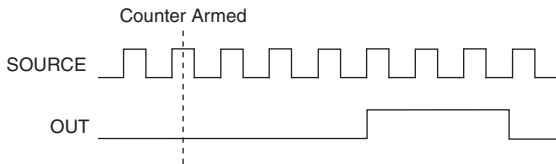

Single Pulse Generation with Start Trigger

The counter can output a single pulse in response to one pulse on a hardware Start Trigger signal. The pulse appears on the Counter n Internal Output signal of the counter.

You can route the Start Trigger signal to the Gate input of the counter. You can specify a delay from the Start Trigger to the beginning of the pulse. You can also specify the pulse width. The delay and pulse width are measured in terms of a number of active edges of the Source input.

After the Start Trigger signal pulses once, the counter ignores the Gate input.

Figure 7-28 shows a generation of a pulse with a pulse delay of four and a pulse width of three (using the rising edge of Source).

Figure 7-28. Single Pulse Generation with Start Trigger

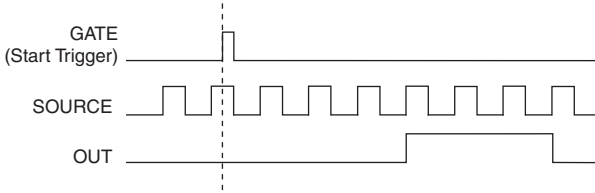

Pulse Train Generation

Refer to the following sections for more information about the X Series pulse train generation options:

- [Finite Pulse Train Generation](#)
- [Retriggerable Pulse or Pulse Train Generation](#)
- [Continuous Pulse Train Generation](#)
- [Finite Implicit Buffered Pulse Train Generation](#)
- [Continuous Buffered Implicit Pulse Train Generation](#)
- [Finite Buffered Sample Clocked Pulse Train Generation](#)
- [Continuous Buffered Sample Clocked Pulse Train Generation](#)

Finite Pulse Train Generation

Finite pulse train generation creates a train of pulses with programmable frequency and duty cycle for a predetermined number of pulses, as shown in Figure 7-29. With X Series counters, the primary counter generates the specified pulse train and the embedded counter counts the pulses generated by the primary counter. When the embedded counter reaches the specified tick count, it generates a trigger that stops the primary counter generation.

Figure 7-29. Finite Pulse Train Generation: Four Ticks Initial Delay, Four Pulses

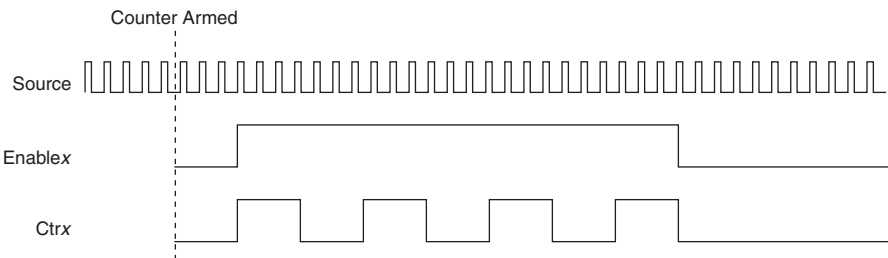

In Legacy Mode, the counter operation requires two counters and does not use the embedded counter. For example, to generate four pulses on Counter 0, Counter 0 generates the pulse train, which is gated by the paired second counter. The paired counter, Counter 1, generates a pulse of desired width.



Note Counter 0 is always paired with Counter 1. Counter 2 is always paired with Counter 3.

The routing is done internally. Figure 7-30 shows an example finite pulse train timing diagram.

Figure 7-30. Finite Pulse Train Timing in Legacy Mode

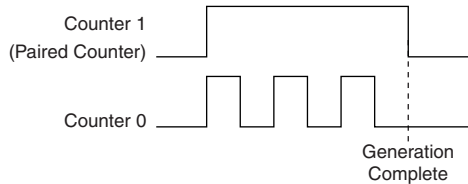

Retriggerable Pulse or Pulse Train Generation

The counter can output a single pulse or multiple pulses in response to each pulse on a hardware Start Trigger signal. The generated pulses appear on the Counter n Internal Output signal of the counter.

You can route the Start Trigger signal to the Gate input of the counter. You can specify a delay from the Start Trigger to the beginning of each pulse. You can also specify the pulse width. The delay and pulse width are measured in terms of a number of active edges of the Source input. The initial delay can be applied to only the first trigger or to all triggers using the `CO.EnableInitialDelayOnRetrigger` property. The default for a single pulse is `True`, while the default for finite pulse trains is `False`.

The counter ignores the Gate input while a pulse generation is in progress. After the pulse generation is finished, the counter waits for another Start Trigger signal to begin another pulse generation. For retriggered pulse generation, pause triggers are not allowed since the pause trigger also uses the gate input.

Figure 7-31 shows a generation of two pulses with a pulse delay of five and a pulse width of three (using the rising edge of Source) with CO.EnableInitialDelayOnRetrigger set to the default True.

Figure 7-31. Retriggerable Single Pulse Generation with Initial Delay on Retrigger

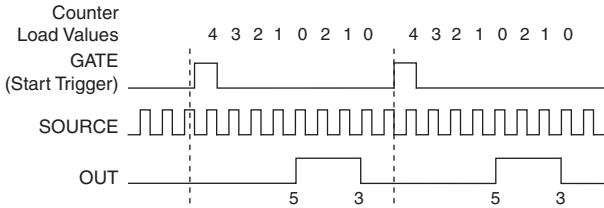
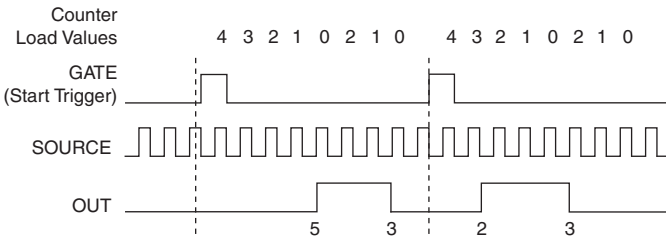

Figure 7-32 shows the same pulse train with CO.EnableInitialDelayOnRetrigger set to the default False.

Figure 7-32. Retriggerable Single Pulse Generation with Initial Delay on Retrigger Set to False



Note The minimum time between the trigger and the first active edge is two ticks of the source.

For information about connecting counter signals, refer to the [Default Counter/Timer Pins](#) section.

Continuous Pulse Train Generation

Continuous pulse train generation creates a train of pulses with programmable frequency and duty cycle. The pulses appear on the Counter *n* Internal Output signal of the counter.

You can specify a delay from when the counter is armed to the beginning of the pulse train. The delay is measured in terms of a number of active edges of the Source input.

You specify the high and low pulse widths of the output signal. The pulse widths are also measured in terms of a number of active edges of the Source input. You can also specify the active edge of the Source input (rising or falling).

The counter can begin the pulse train generation as soon as the counter is armed, or in response to a hardware Start Trigger. You can route the Start Trigger to the Gate input of the counter.

You can also use the Gate input of the counter as a Pause Trigger (if it is not used as a Start Trigger). The counter pauses pulse generation when the Pause Trigger is active.

Figure 7-33 shows a continuous pulse train generation (using the rising edge of Source).

Figure 7-33. Continuous Pulse Train Generation

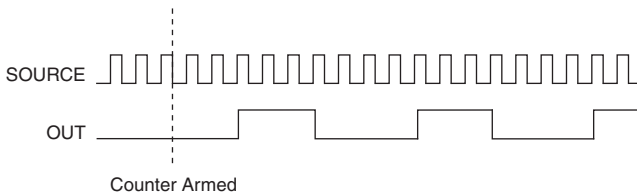

Continuous pulse train generation is sometimes called frequency division. If the high and low pulse widths of the output signal are M and N periods, then the frequency of the Counter n Internal Output signal is equal to the frequency of the Source input divided by $M + N$.

For information about connecting counter signals, refer to the [Default Counter/Timer Pins](#) section.

Buffered Pulse Train Generation

X Series counters can use the FIFO to perform a buffered pulse train generation. Buffered pulse train generation can use implicit timing or sample clock timing. When using implicit timing, the pulse idle time and active time changes with each sample you write. With sample clocked timing, each sample you write updates the idle time and active time of your generation on each sample clock edge. Idle time and active time can also be defined in terms of frequency and duty cycle or idle ticks and active ticks.



Note On buffered implicit pulse trains, the pulse specifications in the DAQmx Create Counter Output Channel are ignored so that you generate the number of pulses defined in the multipoint write. On buffered sample clock pulse trains, the pulse specifications in the DAQmx Create Counter Output Channel are generated after the counters start, and before the first sample clock, so that you generate the number of updates defined in the multipoint write.

Finite Implicit Buffered Pulse Train Generation

Finite implicit buffered pulse train generation creates a predetermined number of pulses with variable idle and active times. Each point you write generates a single pulse. The number of pairs of idle and active times (pulse specifications) you write determines the number of pulses generated. All points are generated back to back to create a user defined pulse train.

Table 7-6 and Figure 7-34 detail a finite implicit generation of three samples.

Table 7-6. Finite Implicit Buffered Pulse Train Generation

Sample	Idle Ticks	Active Ticks
1	2	2
2	3	4
3	2	2

Figure 7-34. Finite Implicit Buffered Pulse Train Generation

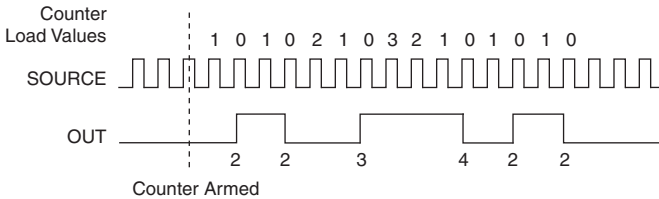

Continuous Buffered Implicit Pulse Train Generation

Continuous buffered implicit pulse train generation creates a continuous train of pulses with variable idle and active times. Instead of generating a set number of data samples and stopping, a continuous generation continues until you stop the operation. Each point you write generates a single pulse. All points are generated back to back to create a user defined pulse train.

Finite Buffered Sample Clocked Pulse Train Generation

Finite buffered sample clocked pulse train generation creates a predetermined number of pulse train updates. Each point you write defines pulse specifications that are updated with each sample clock. When a sample clock occurs, the current pulse (idle followed by active) finishes generation and the next pulse updates with the next sample specifications.



Note When the last sample is generated, the pulse train continues to generate with these specifications until the task is stopped.

Table 7-7 and Figure 7-35 detail a finite sample clocked generation of three samples where the pulse specifications from the create channel are two ticks idle, two ticks active, and three ticks initial delay.

Table 7-7. Finite Buffered Sample Clocked Pulse Train Generation

Sample	Idle Ticks	Active Ticks
1	3	3
2	2	2
3	3	3

Figure 7-35. Finite Buffered Sample Clocked Pulse Train Generation

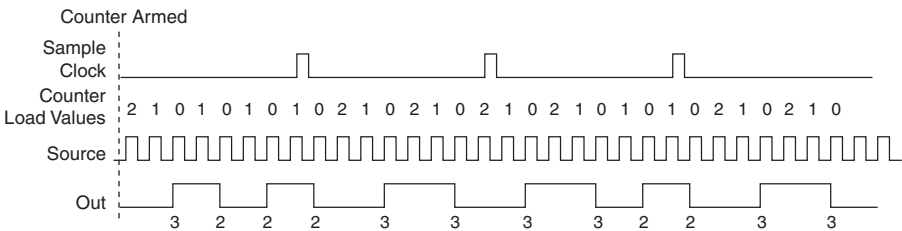

There are several different methods of continuous generation that control what data is written. These methods are regeneration, FIFO regeneration, and non-regeneration modes.

Regeneration is the repetition of the data that is already in the buffer.

Standard regeneration is when data from the PC buffer is continually downloaded to the FIFO to be written out. New data can be written to the PC buffer at any time without disrupting the output. With FIFO regeneration, the entire buffer is downloaded to the FIFO and regenerated from there. Once the data is downloaded, new data cannot be written to the FIFO. To use FIFO regeneration, the entire buffer must fit within the FIFO size. The advantage of using FIFO regeneration is that it does not require communication with the main host memory once the operation is started, thereby preventing any problems that may occur due to excessive bus traffic.

With non-regeneration, old data is not repeated. New data must be continually written to the buffer. If the program does not write new data to the buffer at a fast enough rate to keep up with the generation, the buffer underflows and causes an error.

Continuous Buffered Sample Clocked Pulse Train Generation

Continuous buffered sample clocked pulse train generation creates a continuous train of pulses with variable idle and active times. Instead of generating a set number of data samples and stopping, a continuous generation continues until you stop the operation. Each point you write

specifies pulse specifications that are updated with each sample clock. When a sample clock occurs, the current pulse finishes generation and the next pulse uses the next sample specifications.

Frequency Generation

You can generate a frequency by using a counter in pulse train generation mode or by using the frequency generator circuit, as described in the *Using the Frequency Generator* section.

Using the Frequency Generator

The frequency generator can output a square wave at many different frequencies. The frequency generator is independent of the four general-purpose 32-bit counter/timer modules on X Series devices.

Figure 7-36 shows a block diagram of the frequency generator.

Figure 7-36. Frequency Generator Block Diagram

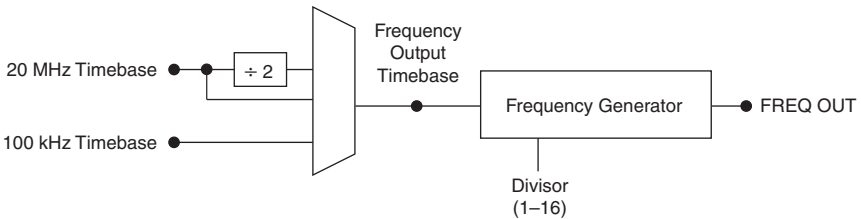

The frequency generator generates the Frequency Output signal. The Frequency Output signal is the Frequency Output Timebase divided by a number you select from 1 to 16. The Frequency Output Timebase can be either the 20 MHz Timebase, the 20 MHz Timebase divided by 2, or the 100 kHz Timebase.

The duty cycle of Frequency Output is 50% if the divisor is either 1 or an even number. For an odd divisor, suppose the divisor is set to D . In this case, Frequency Output is low for $(D + 1)/2$ cycles and high for $(D - 1)/2$ cycles of the Frequency Output Timebase.

Figure 7-37 shows the output waveform of the frequency generator when the divisor is set to 5.

Figure 7-37. Frequency Generator Output Waveform

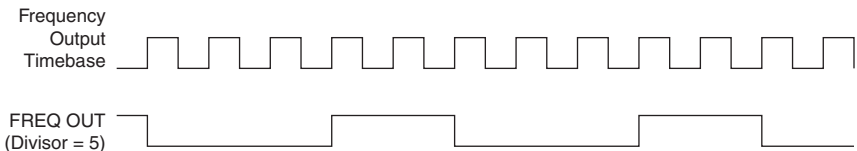

Frequency Output can be routed out to any PFI <0..15> or RTSI <0..7> terminal. All PFI terminals are set to high-impedance at startup. The FREQ OUT signal can also be routed to many internal timing signals.

In software, program the frequency generator as you would program one of the counters for pulse train generation.

For information about connecting counter signals, refer to the [Default Counter/Timer Pins](#) section.

Frequency Division

The counters can generate a signal with a frequency that is a fraction of an input signal. This function is equivalent to continuous pulse train generation. Refer to the [Continuous Pulse Train Generation](#) section for detailed information.

For information about connecting counter signals, refer to the [Default Counter/Timer Pins](#) section.

Pulse Generation for ETS

In the equivalent time sampling (ETS) application, the counter produces a pulse on the output a specified delay after an active edge on Gate. After each active edge on Gate, the counter cumulatively increments the delay between the Gate and the pulse on the output by a specified amount. Thus, the delay between the Gate and the pulse produced successively increases.

The increase in the delay value can be between 0 and 255. For instance, if you specify the increment to be 10, the delay between the active Gate edge and the pulse on the output increases by 10 every time a new pulse is generated.

Suppose you program your counter to generate pulses with a delay of 100 and pulse width of 200 each time it receives a trigger. Furthermore, suppose you specify the delay increment to be 10. On the first trigger, your pulse delay is 100, on the second it is 110, on the third it is 120; the process repeats until the counter is disarmed. The counter ignores any Gate edge that is received while the pulse triggered by the previous Gate edge is in progress.

The waveform thus produced at the counter's output can be used to provide timing for undersampling applications where a digitizing system can sample repetitive waveforms that are higher in frequency than the Nyquist frequency of the system. Figure 7-38 shows an example of pulse generation for ETS; the delay from the trigger to the pulse increases after each subsequent Gate active edge.

Figure 7-38. Pulse Generation for ETS

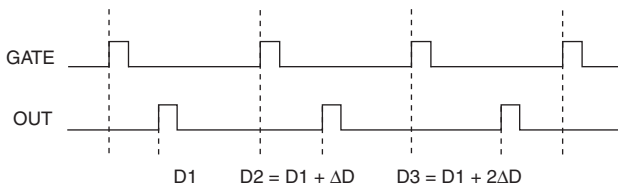

For information about connecting counter signals, refer to the [Default Counter/Timer Pins](#) section.

Counter Timing Signals

X Series devices feature the following counter timing signals:

- [Counter *n* Source Signal](#)
- [Counter *n* Gate Signal](#)
- [Counter *n* Aux Signal](#)
- [Counter *n* A Signal](#)
- [Counter *n* B Signal](#)
- [Counter *n* Z Signal](#)
- [Counter *n* Up_Down Signal](#)
- [Counter *n* HW Arm Signal](#)
- [Counter *n* Sample Clock Signal](#)
- [Counter *n* Internal Output Signal](#)
- [Counter *n* TC Signal](#)
- [Frequency Output Signal](#)



Note All counter timing signals can be filtered. Refer to the [PFI Filters](#) section of Chapter 8, [PFI](#), for more information.

In this section, *n* refers to the X Series Counter 0, 1, 2, or 3. For example, Counter *n* Source refers to four signals—Counter 0 Source (the source input to Counter 0), Counter 1 Source (the source input to Counter 1), Counter 2 Source (the source input to Counter 2), or Counter 3 Source (the source input to Counter 3).

Each of these signals supports digital filtering. Refer to the [PFI Filters](#) section of Chapter 8, [PFI](#), for more information.

Counter *n* Source Signal

The selected edge of the Counter *n* Source signal increments and decrements the counter value depending on the application the counter is performing. Table 7-8 lists how the terminal is used in various applications.

Table 7-8. Counter Applications and Counter *n* Source

Application	Purpose of Source Terminal
Pulse Generation	Counter Timebase
One Counter Time Measurements	Counter Timebase

Table 7-8. Counter Applications and Counter *n* Source

Application	Purpose of Source Terminal
Two Counter Time Measurements	Input Terminal
Non-Buffered Edge Counting	Input Terminal
Buffered Edge Counting	Input Terminal
Two-Edge Separation	Counter Timebase

Routing a Signal to Counter *n* Source

Each counter has independent input selectors for the Counter *n* Source signal. Any of the following signals can be routed to the Counter *n* Source input:

- 100 MHz Timebase
- 20 MHz Timebase
- 100 kHz Timebase
- RTSI <0..7>
- PFI <0..15>
- PXI_CLK10
- PXI_STAR
- PXIe_DSTAR<A,B>
- Analog Comparison Event
- Change Detection Event

In addition, TC or Gate from a counter can be routed to a different counter source.

Some of these options may not be available in some driver software.

Routing Counter *n* Source to an Output Terminal

You can route Counter *n* Source out to any PFI <0..15>, RTSI <0..7>, or PXIe_DSTARC terminal. All PFIs are set to high-impedance at startup.

Counter *n* Gate Signal

The Counter *n* Gate signal can perform many different operations depending on the application including starting and stopping the counter, and saving the counter contents.

Routing a Signal to Counter n Gate

Each counter has independent input selectors for the Counter n Gate signal. Any of the following signals can be routed to the Counter n Gate input:

- RTSI <0..7>
- PFI <0..15>
- AI Reference Trigger (ai/ReferenceTrigger)
- AI Start Trigger (ai/StartTrigger)
- AO Sample Clock (ao/SampleClock)
- DI Sample Clock (di/SampleClock)
- DI Reference Trigger (di/ReferenceTrigger)
- DO Sample Clock (do/SampleClock)
- PXI_STAR
- PXIe_DSTAR<A,B>
- Change Detection Event
- Analog Comparison Event

In addition, a counter's Internal Output or Source can be routed to a different counter's gate.

Some of these options may not be available in some driver software.

Routing Counter n Gate to an Output Terminal

You can route Counter n Gate out to any PFI <0..15>, RTSI <0..7>, or PXIe_DSTARC terminal. All PFIs are set to high-impedance at startup.

Counter n Aux Signal

The Counter n Aux signal indicates the first edge in a two-signal edge-separation measurement.

Routing a Signal to Counter n Aux

Each counter has independent input selectors for the Counter n Aux signal. Any of the following signals can be routed to the Counter n Aux input:

- RTSI <0..7>
- PFI <0..15>
- AI Reference Trigger (ai/ReferenceTrigger)
- AI Start Trigger (ai/StartTrigger)
- PXI_STAR
- PXIe_DSTAR<A,B>
- Analog Comparison Event
- Change Detection Event

In addition, a counter's Internal Output, Gate or Source can be routed to a different counter's Aux. A counter's own gate can also be routed to its Aux input.

Some of these options may not be available in some driver software.

Counter *n* A, Counter *n* B, and Counter *n* Z Signals

Counter *n* B can control the direction of counting in edge counting applications. Use the A, B, and Z inputs to each counter when measuring quadrature encoders or measuring two pulse encoders.

Routing Signals to A, B, and Z Counter Inputs

Each counter has independent input selectors for each of the A, B, and Z inputs. Any of the following signals can be routed to each input:

- RTSI <0..7>
- PFI <0..15>
- PXI_STAR
- PXIe_DSTAR<A,B>
- Analog Comparison Event

Routing Counter *n* Z Signal to an Output Terminal

You can route Counter *n* Z out to any RTSI <0..7> terminal.

Counter *n* Up_Down Signal

Counter *n* Up_Down is another name for the Counter *n* B signal.

Counter *n* HW Arm Signal

The Counter *n* HW Arm signal enables a counter to begin an input or output function.

To begin any counter input or output function, you must first enable, or arm, the counter. In some applications, such as a buffered edge count, the counter begins counting when it is armed. In other applications, such as single pulse-width measurement, the counter begins waiting for the Gate signal when it is armed. Counter output operations can use the arm signal in addition to a start trigger.

Software can arm a counter or configure counters to be armed on a hardware signal. Software calls this hardware signal the Arm Start Trigger. Internally, software routes the Arm Start Trigger to the Counter *n* HW Arm input of the counter.

Routing Signals to Counter n HW Arm Input

Any of the following signals can be routed to the Counter n HW Arm input:

- RTSI <0..7>
- PFI <0..15>
- AI Reference Trigger (ai/ReferenceTrigger)
- AI Start Trigger (ai/StartTrigger)
- PXI_STAR
- PXIe_DSTAR<A,B>
- Analog Comparison Event
- Change Detection Event

A counter's Internal Output can be routed to a different counter's HW Arm.

Some of these options may not be available in some driver software.

Counter n Sample Clock Signal

Use the Counter n Sample Clock (Ctr n SampleClock) signal to perform sample clocked acquisitions and generations.

You can specify an internal or external source for Counter n Sample Clock. You can also specify whether the measurement sample begins on the rising edge or falling edge of Counter n Sample Clock.

If the DAQ device receives a Counter n Sample Clock when the FIFO is full, it reports an overflow error to the host software.

Using an Internal Source

To use Counter n Sample Clock with an internal source, specify the signal source and the polarity of the signal. The source can be any of the following signals:

- DI Sample Clock (di/SampleClock)
- DO Sample Clock (do/SampleClock)
- AI Sample Clock (ai/SampleClock)
- AI Convert Clock (ai/ConvertClock)
- AO Sample Clock (ao/SampleClock)
- DI Change Detection output

Several other internal signals can be routed to Counter n Sample Clock through internal routes. Refer to *Device Routing in MAX* in the *NI-DAQmx Help* or the *LabVIEW Help* for more information.

Using an External Source

You can route any of the following signals as Counter n Sample Clock:

- PFI <0..15>
- RTSI <0..7>
- PXI_STAR
- PXIe_DSTAR<A,B>
- Analog Comparison Event

You can sample data on the rising or falling edge of Counter n Sample Clock.

Routing Counter n Sample Clock to an Output Terminal

You can route Counter n Sample Clock out to any PFI <0..15> terminal. The PFI circuitry inverts the polarity of Counter n Sample Clock before driving the PFI terminal.

Counter n Internal Output and Counter n TC Signals

The Counter n Internal Output signal changes in response to Counter n TC.

The two software-selectable output options are pulse output on TC and toggle output on TC. The output polarity is software-selectable for both options.

With pulse or pulse train generation tasks, the counter drives the pulse(s) on the Counter n Internal Output signal. The Counter n Internal Output signal can be internally routed to be a counter/timer input or an “external” source for AI, AO, DI, or DO timing signals.

Routing Counter n Internal Output to an Output Terminal

You can route Counter n Internal Output to any PFI <0..15>, RTSI <0..7>, or PXIe_DSTAR terminal. All PFIs are set to high-impedance at startup.

Frequency Output Signal

The Frequency Output (FREQ OUT) signal is the output of the frequency output generator.

Routing Frequency Output to a Terminal

You can route Frequency Output to any PFI <0..15> or PXIe_DSTAR terminal. All PFIs are set to high-impedance at startup. The FREQ OUT signal can also be routed to DO Sample Clock and DI Sample Clock.

Default Counter/Timer Pins

By default, NI-DAQmx routes the counter/timer inputs and outputs to the PFI pins.

Refer to Table 7-9 for the default NI-DAQmx counter/timer outputs for PCI Express, PXI Express, USB Mass Termination, and USB BNC devices. Refer to Table 7-10 for the default NI-DAQmx counter/timer outputs for USB Screw Terminal devices.



Note (NI USB BNC devices) For NI USB BNC devices, the default connector 0 pin number does not apply.

Table 7-9. X Series PCI Express/PXI Express/USB Mass Termination/USB BNC Device Default NI-DAQmx Counter/Timer Pins

Counter/Timer Signal	Default Connector 0 Pin Number (Name)
CTR 0 SRC	37 (PFI 8)
CTR 0 GATE	3 (PFI 9)
CTR 0 AUX	45 (PFI 10)
CTR 0 OUT	2 (PFI 12)
CTR 0 A	37 (PFI 8)
CTR 0 Z	3 (PFI 9)
CTR 0 B	45 (PFI 10)
CTR 1 SRC	42 (PFI 3)
CTR 1 GATE	41 (PFI 4)
CTR 1 AUX	46 (PFI 11)
CTR 1 OUT	40 (PFI 13)
CTR 1 A	42 (PFI 3)
CTR 1 Z	41 (PFI 4)
CTR 1 B	46 (PFI 11)
CTR 2 SRC	11 (PFI 0)
CTR 2 GATE	10 (PFI 1)
CTR 2 AUX	43 (PFI 2)
CTR 2 OUT	1 (PFI 14)

Table 7-9. X Series PCI Express/PXI Express/USB Mass Termination/USB BNC Device Default NI-DAQmx Counter/Timer Pins (Continued)

Counter/Timer Signal	Default Connector 0 Pin Number (Name)
CTR 2 A	11 (PFI 0)
CTR 2 Z	10 (PFI 1)
CTR 2 B	43 (PFI 2)
CTR 3 SRC	6 (PFI 5)
CTR 3 GATE	5 (PFI 6)
CTR 3 AUX	38 (PFI 7)
CTR 3 OUT	39 (PFI 15)
CTR 3 A	6 (PFI 5)
CTR 3 Z	5 (PFI 6)
CTR 3 B	38 (PFI 7)
FREQ OUT	1 (PFI 14)

Table 7-10. X Series USB Screw Terminal Device Default NI-DAQmx Counter/Timer Pins

Counter/Timer Signal	Default Pin Number (Name)
CTR 0 SRC	81 (PFI 8)
CTR 0 GATE	83 (PFI 9)
CTR 0 AUX	85 (PFI 10)
CTR 0 OUT	89 (PFI 12)
CTR 0 A	81 (PFI 8)
CTR 0 Z	83 (PFI 9)
CTR 0 B	85 (PFI 10)
CTR 1 SRC	76 (PFI 3)
CTR 1 GATE	77 (PFI 4)
CTR 1 AUX	87 (PFI 11)
CTR 1 OUT	91 (PFI 13)

Table 7-10. X Series USB Screw Terminal Device Default NI-DAQmx Counter/Timer Pins (Continued)

Counter/Timer Signal	Default Pin Number (Name)
CTR 1 A	76 (PFI 3)
CTR 1 Z	77 (PFI 4)
CTR 1 B	87 (PFI 11)
CTR 2 SRC	73 (PFI 0)
CTR 2 GATE	74 (PFI 1)
CTR 2 AUX	75 (PFI 2)
CTR 2 OUT	93 (PFI 14)
CTR 2 A	73 (PFI 0)
CTR 2 Z	74 (PFI 1)
CTR 2 B	75 (PFI 2)
CTR 3 SRC	78 (PFI 5)
CTR 3 GATE	79 (PFI 6)
CTR 3 AUX	80 (PFI 7)
CTR 3 OUT	95 (PFI 15)
CTR 3 A	78 (PFI 5)
CTR 3 Z	79 (PFI 6)
CTR 3 B	80 (PFI 7)
FREQ OUT	93 (PFI 14)

You can use these defaults or select other sources and destinations for the counter/timer signals in NI-DAQmx. Refer to *Connecting Counter Signals* in the *NI-DAQmx Help* or the *LabVIEW Help* for more information about how to connect your signals for common counter measurements and generations. X Series default PFI lines for counter functions are listed in *X Series Physical Channels* in the *NI-DAQmx Help* or the *LabVIEW Help*.

Counter Triggering

Counters support three different triggering actions:

- **Arm Start Trigger**—To begin any counter input or output function, you must first enable, or arm, the counter. Software can arm a counter or configure counters to be armed on a hardware signal. Software calls this hardware signal the Arm Start Trigger. Internally, software routes the Arm Start Trigger to the Counter n HW Arm input of the counter.

For counter output operations, you can use it in addition to the start and pause triggers. For counter input operations, you can use the arm start trigger to have start trigger-like behavior. The arm start trigger can be used for synchronizing multiple counter input and output tasks.

When using an arm start trigger, the arm start trigger source is routed to the Counter n HW Arm signal.

- **Start Trigger**—For counter output operations, a start trigger can be configured to begin a finite or continuous pulse generation. Once a continuous generation has triggered, the pulses continue to generate until you stop the operation in software. For finite generations, the specified number of pulses is generated and the generation stops unless you use the retriggerable attribute. When you use this attribute, subsequent start triggers cause the generation to restart.

When using a start trigger, the start trigger source is routed to the Counter n Gate signal input of the counter.

Counter input operations can use the arm start trigger to have start trigger-like behavior.

- **Pause Trigger**—You can use pause triggers in edge counting and continuous pulse generation applications. For edge counting acquisitions, the counter stops counting edges while the external trigger signal is low and resumes when the signal goes high or vice versa. For continuous pulse generations, the counter stops generating pulses while the external trigger signal is low and resumes when the signal goes high or vice versa.

When using a pause trigger, the pause trigger source is routed to the Counter n Gate signal input of the counter.

Other Counter Features

The following sections list the other counter features available on X Series devices.

Cascading Counters

You can internally route the Counter n Internal Output and Counter n TC signals of each counter to the Gate inputs of the other counter. By cascading two counters together, you can effectively create a 64-bit counter. By cascading counters, you can also enable other applications. For example, to improve the accuracy of frequency measurements, use reciprocal frequency measurement, as described in the [Large Range of Frequencies with Two Counters](#) section.

Prescaling

Prescaling allows the counter to count a signal that is faster than the maximum timebase of the counter, as shown in Figure 7-39. X Series devices offer 8X and 2X prescaling on each counter (prescaling can be disabled). Each prescaler consists of a small, simple counter that counts to eight (or two) and rolls over. This counter can run faster than the larger counters, which simply count the rollovers of this smaller counter. Thus, the prescaler acts as a frequency divider on the Source and puts out a frequency that is one-eighth (or one-half) of what it is accepting.

Figure 7-39. Prescaling

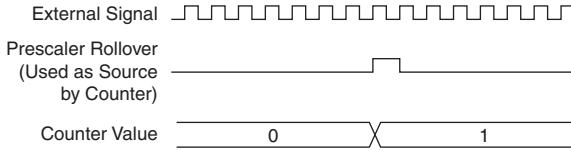

Prescaling is intended to be used for frequency measurement where the measurement is made on a continuous, repetitive signal. The prescaling counter cannot be read; therefore, you cannot determine how many edges have occurred since the previous rollover. Prescaling can be used for event counting provided it is acceptable to have an error of up to seven (or one) ticks. Prescaling can be used when the counter Source is an external signal. Prescaling is not available if the counter Source is one of the internal timebases (100MHzTimebase, 20MHzTimebase, or 100kHzTimebase).

Synchronization Modes

The 32-bit counter counts up or down synchronously with the Source signal. The Gate signal and other counter inputs are asynchronous to the Source signal, so X Series devices synchronize these signals before presenting them to the internal counter.

Depending on how you configure your device, X Series devices use one of three synchronization methods:

- *100 MHz Source Mode*
- *External Source Greater than 25 MHz*
- *External or Internal Source Less than 25 MHz*

100 MHz Source Mode

In 100 MHz source mode, the device synchronizes signals on the rising edge of the source, and counts on the third rising edge of the source. Edges are pipelined so no counts are lost, as shown in Figure 7-40.

Figure 7-40. 100 MHz Source Mode

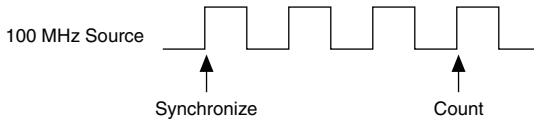

External Source Greater than 25 MHz

With an external source greater than 25 MHz, the device synchronizes signals on the rising edge of the source, and counts on the third rising edge of the source. Edges are pipelined so no counts are lost, as shown in Figure 7-41.

Figure 7-41. External Source Greater than 25 MHz

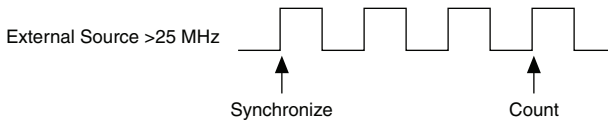

External or Internal Source Less than 25 MHz

With an external or internal source less than 25 MHz, the device generates a delayed Source signal by delaying the Source signal by several nanoseconds. The device synchronizes signals on the rising edge of the delayed Source signal, and counts on the following rising edge of the source, as shown in Figure 7-42.

Figure 7-42. External or Internal Source Less than 25 MHz

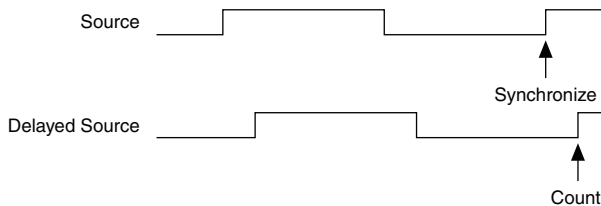

PFI

X Series devices have up to 16 Programmable Function Interface (PFI) signals. In addition, X Series devices have up to 32 lines of bidirectional DIO signals.

Each PFI can be individually configured as the following:

- A static digital input
- A static digital output
- A timing input signal for AI, AO, DI, DO, or counter/timer functions
- A timing output signal from AI, AO, DI, DO, or counter/timer functions

Each PFI input also has a programmable debouncing filter. Figure 8-1 shows the circuitry of one PFI line. Each PFI line is similar.

Figure 8-1. X Series PFI Circuitry

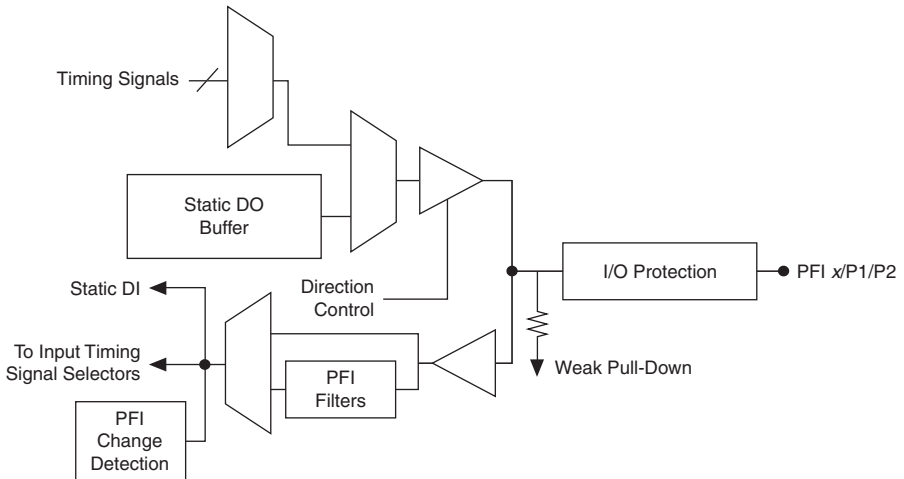

When a terminal is used as a timing input or output signal, it is called PFI x (where x is an integer from 0 to 15). When a terminal is used as a static digital input or output, it is called P1. x or P2. x . On the I/O connector, each terminal is labeled PFI x /P1. x or PFI x /P2. x .

The voltage input and output levels and the current drive levels of the PFI signals are listed in the device specifications

Using PFI Terminals as Timing Input Signals

Use PFI terminals to route external timing signals to many different X Series functions. Each PFI terminal can be routed to any of the following signals:

- **(NI 632X/634X/6351/6353/6355/6361/6363/6365/6375 Devices)** AI Convert Clock (ai/ConvertClock)
- AI Sample Clock (ai/SampleClock)
- AI Start Trigger (ai/StartTrigger)
- AI Reference Trigger (ai/ReferenceTrigger)
- AI Pause Trigger (ai/PauseTrigger)
- AI Sample Clock Timebase (ai/SampleClockTimebase)
- AO Start Trigger (ao/StartTrigger)
- AO Sample Clock (ao/SampleClock)
- AO Sample Clock Timebase (ao/SampleClockTimebase)
- AO Pause Trigger (ao/PauseTrigger)
- Counter input signals for all counters—Source, Gate, Aux, HW_Arm, A, B, Z
- Counter *n* Sample Clock
- DI Sample Clock (di/SampleClock)
- DI Sample Clock Timebase (di/SampleClockTimebase)
- DI Reference Trigger (di/ReferenceTrigger)
- DO Sample Clock (do/SampleClock)

Most functions allow you to configure the polarity of PFI inputs and whether the input is edge or level sensitive.



Note (NI PXIe-6386/6396 Devices) PXIe-6386 and PXIe-6396 devices differ in several ways from other SMIO devices. For more information about sample clock rates related to these devices, go to ni.com/info and enter the Info Code `smio14ms`.

Exporting Timing Output Signals Using PFI Terminals

You can route any of the following timing signals to any PFI terminal configured as an output:

- **(NI 632X/634X/6351/6353/6355/6361/6363/6365/6375 Devices)** AI Convert Clock* (ai/ConvertClock)
- AI Hold Complete Event (ai/HoldCompleteEvent)
- AI Reference Trigger (ai/ReferenceTrigger)
- AI Sample Clock (ai/SampleClock)

- AI Start Trigger (ai/StartTrigger)
- AI Pause Trigger (ai/PauseTrigger)
- AO Sample Clock* (ao/SampleClock)
- AO Start Trigger (ao/StartTrigger)
- AO Pause Trigger (ao/PauseTrigger)
- DI Sample Clock (di/SampleClock)
- DI Start Trigger (di/StartTrigger)
- DI Reference Trigger (di/ReferenceTrigger)
- DI Pause Trigger (di/PauseTrigger)
- DO Sample Clock* (do/SampleClock)
- DO Start Trigger (do/StartTrigger)
- DO Pause Trigger (do/PauseTrigger)
- Counter n Source
- Counter n Gate
- Counter n Internal Output
- Counter n Sample Clock
- Counter n Counter n HW Arm
- Frequency Output
- PXI_STAR
- RTSI <0..7>
- Analog Comparison Event
- Change Detection Event
- Watchdog timer expired pulse



Note Signals with an * are inverted before being driven to a terminal; that is, these signals are active low.



Note (NI PXIe-6386/6396 Devices) PXIe-6386 and PXIe-6396 devices differ in several ways from other SMIO devices. For more information about sample clock rates related to these devices, go to ni.com/info and enter the Info Code `smio14ms`.

Using PFI Terminals as Static Digital I/Os

Each PFI can be individually configured as a static digital input or a static digital output. When a terminal is used as a static digital input or output, it is called P1. x or P2. x . On the I/O connector, each terminal is labeled PFI x /P1. x or PFI x /P2. x .

In addition, X Series devices have up to 32 lines of bidirectional DIO signals.

Using PFI Terminals to Digital Detection Events

Each PFI can be configured to detect digital changes. The values on the PFI lines cannot be read in a hardware-timed task, but they can be used to fire the change detection event. For example, if you wanted to do change detection on eight timed DIO lines but wanted to ensure that the value of the lines was updated every second independent of the eight lines changing you could set a PFI line up for change detection and connect a 1 Hz signal to it.

Connecting PFI Input Signals

All PFI input connections are referenced to D GND. Figure 8-2 shows this reference, and how to connect an external PFI 0 source and an external PFI 2 source to two PFI terminals.

Figure 8-2. PFI Input Signal Connections

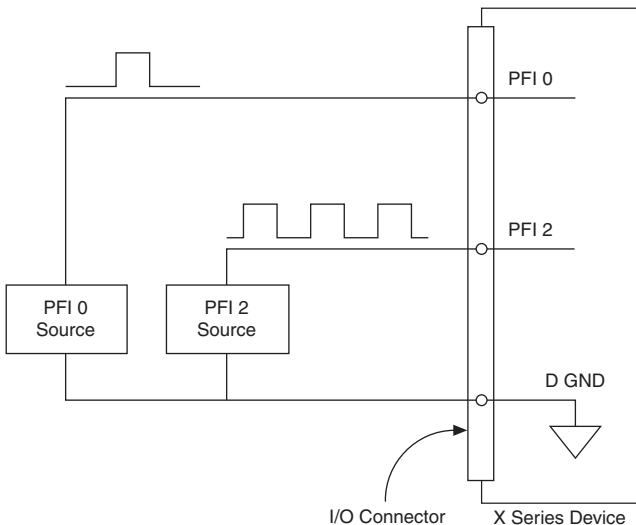

PFI Filters

You can enable a programmable debouncing filter on each PFI, RTSI, PXI_STAR, or PXIe_DSTAR<A,B> signal. When the filters are enabled, your device samples the input on each rising edge of a filter clock. X Series devices use an onboard oscillator to generate the filter clock.

The following is an example of low to high transitions of the input signal. High-to-low transitions work similarly.

Assume that an input terminal has been low for a long time. The input terminal then changes from low to high, but glitches several times. When the filter clock has sampled the signal high on N consecutive edges, the low to high transition is propagated to the rest of the circuit. The value of N depends on the filter setting; refer to Table 8-1.

Table 8-1. Filters

Filter Setting	Filter Clock	N (Filter Clocks Needed to Pass Signal)	Pulse Width Guaranteed to Pass Filter	Pulse Width Guaranteed to Not Pass Filter
None	—	—	—	—
90 ns (short)	100 MHz	9	90 ns	80 ns
5.12 μ s (medium)	100 MHz	512	5.12 μ s	5.11 μ s
2.56 ms (high)	100 kHz	256	2.56 ms	2.55 ms
Custom	User configurable	N	N/timebase	(N - 1)/timebase

The filter setting for each input can be configured independently. On power up, the filters are disabled. Figure 8-3 shows an example of a low to high transition on an input that has a custom filter set to N = 5.

Figure 8-3. Filter Example

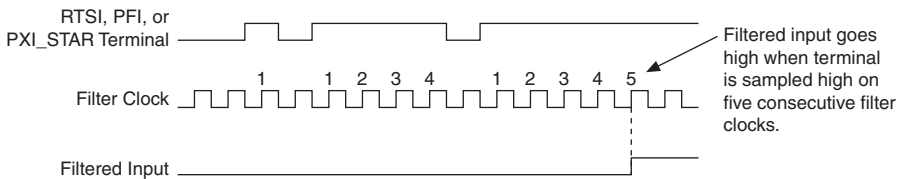

Enabling filters introduces jitter on the input signal. The maximum jitter is one period of the timebase.

When a RTSI input is routed directly to PFI, the X Series device does not use the filtered version of the input signal.

I/O Protection

Each DIO and PFI signal is protected against overvoltage, undervoltage, and overcurrent conditions as well as ESD events. However, you should avoid these fault conditions by following these guidelines:

- If you configure a PFI or DIO line as an output, do *not* connect it to any external signal source, ground, or power supply.
- If you configure a PFI or DIO line as an output, understand the current requirements of the load connected to these signals. Do *not* exceed the specified current output limits of the DAQ device. NI has several signal conditioning solutions for digital applications requiring high current drive.
- If you configure a PFI or DIO line as an input, do *not* drive the line with voltages outside of its normal operating range. The PFI or DIO lines have a smaller operating range than the AI signals.
- Treat the DAQ device as you would treat any static sensitive device. *Always* properly ground yourself and the equipment when handling the DAQ device or connecting to it.

Programmable Power-Up States

At system startup and reset, the hardware sets all PFI and DIO lines to high-impedance inputs by default. The DAQ device does not drive the signal high or low. Each line has a weak pull-down resistor connected to it, as described in the device specifications.

NI-DAQmx supports programmable power-up states for PFI and DIO lines. Software can program any value at power up to the P0, P1, or P2 lines. The PFI and DIO lines can be set as:

- A high-impedance input with a weak pull-down resistor (default)
- An output driving a 0
- An output driving a 1

Refer to the *NI-DAQmx Help* or the *LabVIEW Help* for more information about setting power-up states in NI-DAQmx or MAX.



Note When using your X Series device to control an SCXI chassis, DIO lines 0, 1, 2, and 4 are used as communication lines and must be left to power-up in the default high-impedance state to avoid potential damage to these signals.

Digital Routing and Clock Generation

The digital routing circuitry has the following main functions:

- Manages the flow of data between the bus interface and the acquisition/generation sub-systems (analog input, analog output, digital I/O, and the counters). The digital routing circuitry uses FIFOs (if present) in each sub-system to ensure efficient data movement.
- Routes timing and control signals. The acquisition/generation sub-systems use these signals to manage acquisitions and generations. These signals can come from the following sources:
 - Your X Series device
 - Other devices in your system through RTSI
 - User input through the PFI terminals
 - User input through the PXI_STAR terminal
- Routes and generates the main clock signals for the X Series device.

Clock Routing

Figure 9-1 shows the clock routing circuitry of an X Series device.

Figure 9-1. X Series Clock Routing Circuitry

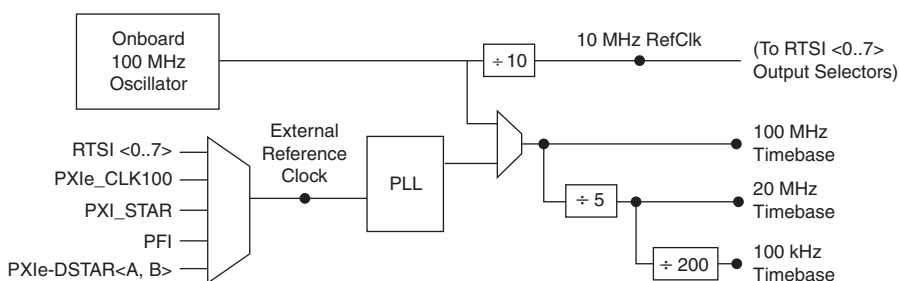

Note (NI PXIe-6386/6396 Devices) PXIe-6386 and PXIe-6396 devices only support PXIe_CLK100 and the onboard oscillator. For more information about special considerations for these devices, go to ni.com/info and enter the Info Code `smio14ms`.

100 MHz Timebase

The 100 MHz Timebase can be used as the timebase for all internal subsystems.

The 100 MHz Timebase is generated from the following sources:

- Onboard oscillator
- External signal (by using the external reference clock)

20 MHz Timebase

The 20 MHz Timebase can be used to generate many of the AI and AO timing signals. The 20 MHz Timebase can also be used as the Source input to the 32-bit general-purpose counter/timers.

The 20 MHz Timebase is generated by dividing down the 100 MHz Timebase.

100 kHz Timebase

The 100 kHz Timebase can be used to generate many of the AI and AO timing signals. The 100 kHz Timebase can also be used as the Source input to the 32-bit general-purpose counter/timers.

The 100 kHz Timebase is generated by dividing down the 20 MHz Timebase by 200.

External Reference Clock

The external reference clock can be used as a source for the internal timebases (100 MHz Timebase, 20 MHz Timebase, and 100 kHz Timebase) on an X Series device.

By using the external reference clock, you can synchronize the internal timebases to an external clock.

The following signals can be routed to drive the external reference clock:

- RTSI <0..7>
- PFI <0..15>
- PXIe_CLK100
- PXI_STAR
- PXIe_DSTAR<A,B>



Note (NI PXIe-6386/6396 Devices) PXIe-6386 and PXIe-6396 devices differ in several ways from other SMIO devices. For more information about these devices related to external reference clocks, go to ni.com/info and enter the Info Code `smio14ms`.

The external reference clock is an input to a Phase-Lock Loop (PLL). The PLL generates the internal timebases.



Caution Do *not* disconnect an external reference clock once the devices have been synchronized or are used by a task. Doing so may cause the device to go into an unknown state. Make sure that all tasks using a reference clock are stopped before disconnecting it.

Enabling or disabling the PLL through the use of a reference clock affects the clock distribution to all subsystems. For this reason, the PLL can only be enabled or disabled when no other tasks are running in any of the device subsystems.

10 MHz Reference Clock

The 10 MHz reference clock can be used to synchronize other devices to your X Series device. The 10 MHz reference clock can be routed to the RTSI <0..7> or PFI <0..15> terminals. Other devices connected to the RTSI bus can use this signal as a clock input.

The 10 MHz reference clock is generated by dividing down the onboard oscillator.

Synchronizing Multiple Devices

The following sections contain information about synchronizing multiple X Series devices.

PXI Express Devices

On PXI Express systems, you can synchronize devices to PXIe_CLK100. In this application, the PXI Express chassis acts as the initiator. Each PXI Express module routes PXIe_CLK100 to its external reference clock.

Another option in PXI Express systems is to use PXI_STAR. The Star Trigger controller device acts as the initiator and drives PXI_STAR with a clock signal. Each target device routes PXI_STAR to its external reference clock.



Note (NI PXIe-6386/6396 Devices) PXIe-6386 and PXIe-6396 devices differ in several ways from other SMIO devices. For more information about these devices related to synchronization, go to ni.com/info and enter the Info Code `smio14ms`.

PCI Express Devices

With the RTSI and PFI buses and the routing capabilities of X Series PCI Express devices, there are several ways to synchronize multiple devices depending on your application.

To synchronize multiple devices to a common timebase, choose one device—the initiator—to generate the timebase. The initiator device routes its 10 MHz reference clock to one of the RTSI <0..7> or PFI <0..15> signals.

All devices (including the initiator device) receive the 10 MHz reference clock from RTSI or PFI. This signal becomes the external reference clock. A PLL on each device generates the internal timebases synchronous to the external reference clock.

Once all of the devices are using or referencing a common timebase, you can synchronize operations across them by sending a common start trigger out across the RTSI or PFI bus and setting their sample clock rates to the same value.

USB Devices

With the PFI bus and the routing capabilities of USB X Series devices, there are several ways to synchronize multiple devices depending on your application.

To synchronize multiple devices to a common timebase, choose one device—the initiator—to generate the timebase. The initiator device routes its 10 MHz reference clock to one of the PFI <0..15> signals.

All devices (including the initiator device) receive the 10 MHz reference clock from PFI. This signal becomes the external reference clock. A PLL on each device generates the internal timebases synchronous to the external reference clock.

Once all of the devices are using or referencing a common timebase, you can synchronize operations across them by sending a common start trigger out across the PFI bus and setting their sample clock rates to the same value.

Real-Time System Integration (RTSI)

Real-Time System Integration (RTSI) is a signal bus among devices that allows you to do the following:

- Use a common clock (or timebase) to drive the timing engine on multiple devices
- Share trigger signals between devices

Many National Instruments DAQ, motion, vision, and CAN devices support RTSI.

In a PCI Express system, the RTSI bus consists of the RTSI bus interface and a ribbon cable. The bus can route timing and trigger signals between several functions on as many as five DAQ, vision, motion, or CAN devices in the computer.

In a PXI Express system, the RTSI bus is replaced by the PXI and PXI Express trigger signals on the PXI Express backplane. This bus can route timing and trigger signals between several functions on as many as seven DAQ devices in the system.

USB devices do not support the RTSI bus.

RTSI Connector Pinout

(NI PCI Express Devices) Figure 9-2 shows the RTSI connector pinout and Table 9-1 describes the RTSI signals.

Figure 9-2. PCI Express RTSI Pinout

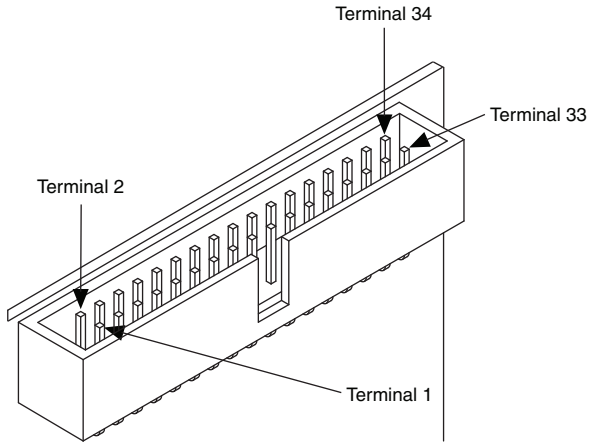

Table 9-1. RTSI Signals

RTSI Bus Signal	Terminal
RTSI 7	34
RTSI 6	32
RTSI 5	30
RTSI 4	28
RTSI 3	26
RTSI 2	24
RTSI 1	22
RTSI 0	20
Not Connected. Do not connect signals to these terminals.	1 through 18
D GND	19, 21, 23, 25, 27, 29, 31, 33

Using RTSI as Outputs

RTSI <0..7> are bidirectional terminals. As an output, you can drive any of the following signals to any RTSI terminal:

- AI Start Trigger (ai/StartTrigger)
- AI Reference Trigger (ai/ReferenceTrigger)
- AI Convert Clock* (ai/ConvertClock)
- AI Sample Clock (ai/SampleClock)
- AI Pause Trigger (ai/PauseTrigger)
- AO Sample Clock* (ao/SampleClock)
- AO Start Trigger (ao/StartTrigger)
- AO Pause Trigger (ao/PauseTrigger)
- DI Start Trigger (di/StartTrigger)
- DI Sample Clock (di/SampleClock)
- DI Pause Trigger (di/PauseTrigger)
- DI Reference Trigger (di/ReferenceTrigger)
- DO Start Trigger (do/StartTrigger)
- DO Sample Clock* (do/SampleClock)
- DO Pause Trigger (do/PauseTrigger)
- 10 MHz Reference Clock
- Counter *n* Source, Gate, Z, Internal Output
- Change Detection Event
- Analog Comparison Event
- FREQ OUT
- PFI <0..5>



Note Signals with a * are inverted before being driven on the RTSI terminals.

Using RTSI Terminals as Timing Input Signals

You can use RTSI terminals to route external timing signals to many different X Series functions. Each RTSI terminal can be routed to any of the following signals:

- AI Convert Clock (ai/ConvertClock)
- AI Sample Clock (ai/SampleClock)
- AI Start Trigger (ai/StartTrigger)
- AI Reference Trigger (ai/ReferenceTrigger)
- AI Pause Trigger (ai/PauseTrigger)
- AI Sample Clock Timebase (ai/SampleClockTimebase)

- AO Start Trigger (ao/StartTrigger)
- AO Sample Clock (ao/SampleClock)
- AO Sample Clock Timebase (ao/SampleClockTimebase)
- AO Pause Trigger (ao/PauseTrigger)
- Counter input signals for all counters—Source, Gate, Aux, HW_Arm, A, B, or Z
- DI Sample Clock (di/SampleClock)
- DI Start Trigger (di/StartTrigger)
- DI Pause Trigger (di/PauseTrigger)
- DI Reference Trigger (di/ReferenceTrigger)
- DO Sample Clock (do/SampleClock)
- DO Sample Clock Timebase (do/SampleClockTimebase)

Most functions allow you to configure the polarity of RTSI inputs and whether the input is edge or level sensitive.

RTSI Filters

You can enable a programmable debouncing filter on each PFI, RTSI, or PXI_STAR signal. Refer to the *PFI Filters* section of Chapter 8, *PFI*, for more information.

PXI and PXI Express Clock and Trigger Signals

PXI and PXI Express clock and trigger signals are only available on PXI Express devices.

PXle_CLK100

PXle_CLK100 is a common low-skew 100 MHz reference clock for synchronization of multiple modules in a PXI Express measurement or control system. The PXIe backplane is responsible for generating PXle_CLK100 independently to each peripheral slot in a PXI Express chassis. For more information, refer to the *PXI Express Specification* at www.pxisa.org.

PXle_SYNC100

PXle_SYNC100 is a common low-skew 10 MHz reference clock with a 10% duty cycle for synchronization of multiple modules in a PXI Express measurement or control system. This signal is used to accurately synchronize modules using PXle_CLK100 along with those using PXI_CLK10. The PXI Express backplane is responsible for generating PXle_SYNC100 independently to each peripheral slot in a PXI Express chassis. For more information, refer to the *PXI Express Specification* at www.pxisa.org.

PXI_CLK10

PXI_CLK10 is a common low-skew 10 MHz reference clock for synchronization of multiple modules in a PXI measurement or control system. The PXI backplane is responsible for generating PXI_CLK10 independently to each peripheral slot in a PXI chassis.



Note PXI_CLK10 cannot be used as a reference clock for X Series devices.

PXI Triggers

A PXI chassis provides eight bused trigger lines to each module in a system. Triggers may be passed from one module to another, allowing precisely timed responses to asynchronous external events that are being monitored or controlled. Triggers can be used to synchronize the operation of several different PXI peripheral modules.

On X Series devices, the eight PXI trigger signals are synonymous with RTSI <0..7>.

Note that in a PXI chassis with more than eight slots, the PXI trigger lines may be divided into multiple independent buses. Refer to the documentation for your chassis for details.

PXI_STAR Trigger

In a PXI Express system, the Star Trigger bus implements a dedicated trigger line between the system timing slot and the other peripheral slots. The Star Trigger can be used to synchronize multiple devices or to share a common trigger signal among devices.

A Star Trigger controller can be installed in this system timing slot to provide trigger signals to other peripheral modules. Systems that do not require this functionality can install any standard peripheral module in this system timing slot.

An X Series device receives the Star Trigger signal (PXI_STAR) from a Star Trigger controller. PXI_STAR can be used as an external source for many AI, AO, and counter signals.

An X Series device is not a Star Trigger controller. An X Series device can be used in the system timing slot of a PXI system, but the system will not be able to use the Star Trigger feature.

PXI_STAR Filters

You can enable a programmable debouncing filter on each PFI, RTSI, PXIe_DSTAR, or PXI_STAR signal. Refer to the [PFI Filters](#) section of Chapter 8, [PFI](#), for more information.

PXIe_DSTAR<A..C>

PXI Express devices can provide high-quality and high-frequency point-to-point connections between each slot and a system timing slot. These connections come in the form of three low-voltage differential star triggers that create point-to-point, high-frequency connections between a PXI Express system timing module and a peripheral device. Using multiple connections enable you to create more applications because of the increased routing capabilities.

Table 9-2 describes the three differential star (DSTAR) lines and how they are used.

Table 9-2. PXIe_DSTAR Line Descriptions

Trigger Line	Purpose
PXIe_DSTARA	Distributes high-speed, high-quality clock signals from the system timing slot to the peripherals (input).
PXIe_DSTARB	Distributes high-speed, high-quality trigger signals from the system timing slot to the peripherals (input).
PXIe_DSTARC	Sends high-speed, high-quality trigger or clock signals from the peripherals to the system timing slot (output).

The DSTAR lines are only available for PXI Express devices when used with a PXI Express system timing module. For more information, refer to the *PXI Express Specification* at www.pxisa.org.

Bus Interface

The bus interface circuitry of X Series devices efficiently moves data between host memory and the measurement and acquisition circuits. X Series devices are available for the following platforms:

- PCI Express
- PXI Express
- USB

Data Transfer Methods

Refer to the following sections for information about bus interface data transfer methods for X Series devices.

PCI Express/PXI Express Device Data Transfer Methods

The primary ways to transfer data across the PCI Express bus are as follows:

- **Direct Memory Access (DMA)**—DMA is a method to transfer data between the device and computer memory without the involvement of the CPU. This method makes DMA the fastest available data transfer method. NI uses DMA hardware and software technology to achieve high throughput rates and increase system utilization. DMA is the default method of data transfer for PCI Express and PXI Express devices.

NI PCI Express and PXI Express X Series devices have eight fully-independent DMA controllers for high-performance transfers of data blocks. One DMA controller is available for each measurement and acquisition block:

- Analog input
- Analog output
- Counter 0
- Counter 1
- Counter 2
- Counter 3

- Digital waveform generation (digital output)
- Digital waveform acquisition (digital input)

Each DMA controller channel contains a FIFO and independent processes for filling and emptying the FIFO. This allows the buses involved in the transfer to operate independently for maximum performance. Data is transferred simultaneously between the ports. The DMA controller supports burst transfers to and from the FIFO.

Each DMA controller supports several features to optimize PCI Express/PXI Express bus utilization. The DMA controllers pack and unpack data through the FIFOs. This feature allows the DMA controllers to combine multiple 16-bit transfers to the DAQ circuitry into a single 32-bit burst transfer on PCI Express. The DMA controllers also automatically handle unaligned memory buffers on PCI Express/PXI Express.

- **Programmed I/O**—Programmed I/O is a data transfer mechanism where the user’s program is responsible for transferring data. Each read or write call in the program initiates the transfer of data. Programmed I/O is typically used in software-timed (on-demand) operations. Refer to the *Analog Output Data Generation Methods* section of Chapter 5, *Analog Output*, for more information.

USB Device Data Transfer Methods

The primary ways to transfer data across the USB bus are as follows:

- **USB Signal Stream**—USB Signal Stream is a method to transfer data between the device and computer memory using USB bulk transfers without intervention of the microcontroller on the NI device. NI uses USB Signal Stream hardware and software technology to achieve high throughput rates and increase system utilization in USB devices.

USB X Series devices have eight fully-independent USB Signal Stream for high-performance transfers of data blocks. These channels are assigned to the first eight measurement/acquisition circuits that request one.

- **Programmed I/O**—Programmed I/O is a data transfer mechanism where the user’s program is responsible for transferring data. Each read or write call in the program initiates the transfer of data. Programmed I/O is typically used in software-timed (on-demand) operations. Refer to the *Analog Output Data Generation Methods* section of Chapter 5, *Analog Output*, for more information.

PXI Express Considerations

PXI clock and trigger signals are only available on PXI Express devices.

PXI and PXI Express Clock and Trigger Signals

Refer to the *PXI_CLK10*, *PXI Triggers*, *PXI_STAR Trigger*, *PXI_STAR Filters*, *PXIe_DSTAR<A..C>*, *PXIe_CLK100*, and *PXIe_SYNC100* sections of Chapter 9, *Digital Routing and Clock Generation*, for more information about PXI and PXI Express clock and trigger signals.

PXI Express

PXI Express X Series devices can be installed in any PXI Express slot in PXI Express chassis.

PXI Express specifications are developed by the PXI System Alliance (www.pxisa.org).

PXIe DAQ Bandwidth Considerations

In order to continuously transfer large amounts of data, the entire PXI Express system must be designed with sufficient data bandwidth.

Depending on the PXI Express connection to the PXI Express chassis backplane, the bandwidth bottleneck could be due to one of the following: the DAQ task, the backplane connection, a PCIe switch integrated into the PXI Express backplane, or between the connection of a PXI Express remote controller to a host machine (if using MXI).

Different PXI Express chassis have different architectures and per slot bandwidths.

If you are using a high channel count or high-speed MIO/SMIO DAQ device, pay special attention to these factors since buffer overflow or underflow errors can occur as you approach or pass the maximum theoretical system bandwidth.



Note (NI PXIe-6386/6396 Devices) PXIe-6386 and PXIe-6396 devices differ in several ways from other SMIO devices. For more information about throughput considerations for these devices, go to ni.com/info and enter the Info Code `smio14ms`.

USB DAQ Bandwidth Considerations

To transfer large amounts of data continuously, you must account for USB limitations. The maximum theoretical bandwidth for USB 2.0 is 60 MB/s. Typical bandwidth to the host computer from USB DAQ systems could produce lower speeds, depending on the application. Tasks using multiple channels at higher sample rates may experience buffer overflow/underflow errors.

The following sample equation demonstrates typical bandwidth speeds, assuming the smallest data type.

$$16 \text{ channels} \times 2 \text{ MS/s} \times 2 \text{ B/S} = 64 \text{ MB/s}$$



Note Typical speeds for USB 2.0 range from 30 MB/s to 45 MB/s. A bandwidth lower than the theoretical 60 MB/s maximum is not unexpected behavior for USB 2.0.

Data Throughput

The amount of data generated by a single USB DAQ device with all channels acquiring at a maximum sample rate can cause buffer overflow errors if the system is unable to transfer sample data from the device quickly enough. If this occurs, NI-DAQmx software will stop the acquisition and return error -200361, “Onboard device memory overflow...” Buffer overflow errors can be prevented by using data compression and by ensuring the USB DAQ system has sufficient data bandwidth.

Triggering

A trigger is a signal that causes an action, such as starting or stopping the acquisition of data. When you configure a trigger, you must decide how you want to produce the trigger and the action you want the trigger to cause. All X Series devices support internal software triggering, as well as external digital triggering. Some devices also support analog triggering. For information about the different actions triggers can perform for each sub-system of the device, refer to the following sections:

- The *Analog Input Triggering* section of Chapter 4, *Analog Input*
- The *Analog Output Triggering* section of Chapter 5, *Analog Output*
- The *Counter Triggering* section of Chapter 7, *Counters*



Note Not all X Series devices support analog triggering. For more information about triggering compatibility, refer to the device specifications.

Triggering with a Digital Source

Your DAQ device can generate a trigger on a digital signal. You must specify a source and an edge. The digital source can be any of the PFI, RTSI, or PXI_STAR signals.

The edge can be either the rising edge or falling edge of the digital signal. A rising edge is a transition from a low logic level to a high logic level. A falling edge is a high-to-low transition.

Figure 11-1 shows a falling-edge trigger.

Figure 11-1. Falling-Edge Trigger

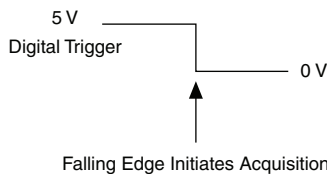

You can also program your DAQ device to perform an action in response to a trigger from a digital source. The action can affect the following:

- Analog input acquisition
- Analog output generation
- Counter behavior
- Digital waveform acquisition and generation

Triggering with an Analog Source

Some X Series devices can generate a trigger on an analog signal. To find your device triggering options, refer to the device specifications.

Figure 11-2 shows the analog trigger circuit on MIO X Series devices.

Figure 11-2. MIO X Series Device Analog Trigger Circuit

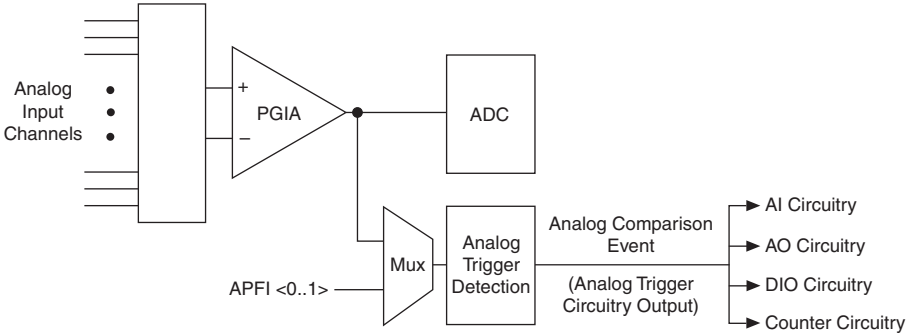
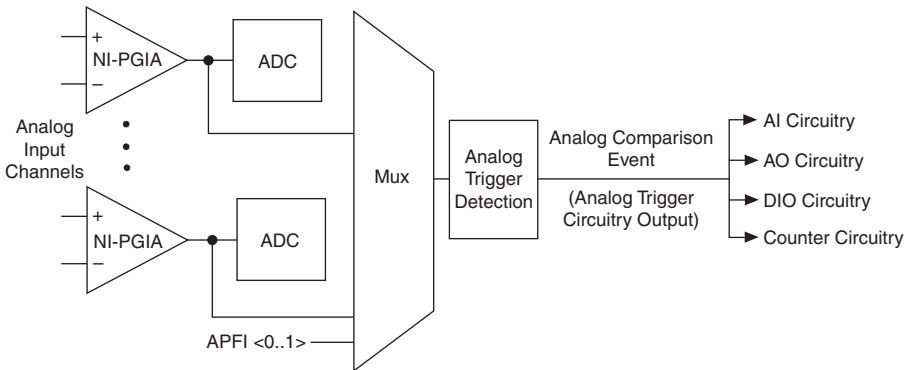

Figure 11-3 shows the analog trigger circuit on Simultaneous MIO X Series devices.

Figure 11-3. Simultaneous MIO X Series Device Analog Trigger Circuitry



You must specify a source and an analog trigger type. The source can be either an APFI <0,1> terminal or an analog input channel.

APFI <0,1> Terminals

When you use either APFI <0,1> terminal as an analog trigger, you should drive the terminal with a low impedance signal source (less than 1 kΩ source impedance). If APFI <0,1> are left unconnected, they are susceptible to crosstalk from adjacent terminals, which can cause false triggering. Note that the APFI <0,1> terminals can also be used for other functions such as the

AO External Reference input, as described in the *AO Reference Selection* section of Chapter 5, *Analog Output*.

Analog Input Channels

Refer to the *Analog Input Channels on MIO X Series Devices* or *Analog Input Channels on Simultaneous MIO X Series Devices* section, depending on your device.

Analog Input Channels on MIO X Series Devices

Select any analog input channel to drive the NI-PGIA. The NI-PGIA amplifies the signal as determined by the input ground-reference setting and the input range. The output of the NI-PGIA then drives the analog trigger detection circuit. By using the NI-PGIA, you can trigger on very small voltage changes in the input signal.

When the DAQ device is waiting for an analog trigger with a AI channel as the source, the AI muxes should not route different AI channels to the NI-PGIA. If a different channel is routed to the NI-PGIA, the trigger condition on the desired channel could be missed. The other channels could also generate false triggers.

This behavior places some restrictions on using AI channels as trigger sources. When you use an analog start trigger, the trigger channel must be the first channel in the channel list. When you use an analog reference or pause trigger, and the analog channel is the source of the trigger, there can be only one channel in the channel list.

Analog Input Channels on Simultaneous MIO X Series Devices

With Simultaneous MIO X Series devices, every AI channel drives its own NI-PGIA. The NI-PGIA amplifies the signal as determined by the input range. The output of the NI-PGIA then drives the analog trigger detection circuit. By using the NI-PGIA, you can trigger on very small voltage changes in the input signal.

Since channels are not multiplexed, there are no restrictions on the analog input channel list order or number of channels with reference and pause triggers. However, the analog input channels must be in the scan list.

Analog Trigger Actions

The output of the analog trigger detection circuit is the Analog Comparison Event signal. You can program your DAQ device to perform an action in response to the Analog Comparison Event signal. The action can affect the following:

- Analog input acquisition
- Analog output generation
- Digital input behavior
- Digital output behavior
- Counter behavior

Routing Analog Comparison Event to an Output Terminal

You can route Analog Comparison Event out to any PFI <0..15> or RTSI <0..7> terminal.

Analog Trigger Types

Configure the analog trigger circuitry to different triggering modes:

- **Analog Edge Triggering**—Configure the analog trigger circuitry to detect when the analog signal is below or above a level you specify.

In below-level analog triggering mode, shown in Figure 11-4, the trigger is generated when the signal value is less than Level.

Figure 11-4. Below-Level Analog Triggering Mode

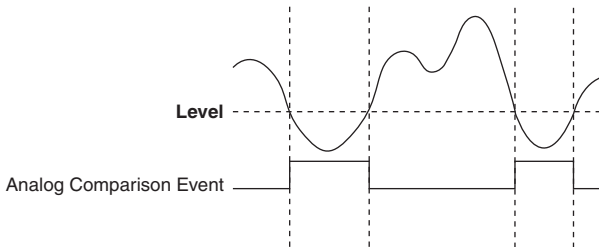

In above-level analog triggering mode, shown in Figure 11-5, the trigger is generated when the signal value is greater than Level.

Figure 11-5. Above-Level Analog Triggering Mode

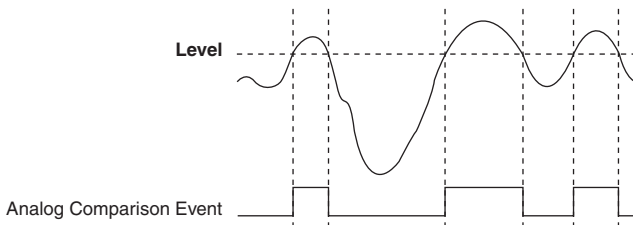

- **Analog Edge Triggering with Hysteresis**—Hysteresis adds a programmable voltage region above or below the trigger level that an input signal must pass through before the DAQ device recognizes a trigger condition, and is often used to reduce false triggering due to noise or jitter in the signal.
 - Analog Edge Trigger with Hysteresis (Rising Slope)—When using hysteresis with a rising slope, you specify a trigger level and amount of hysteresis. The high threshold is the trigger level; the low threshold is the trigger level minus the hysteresis.

For the trigger to assert, the signal must first be below the low threshold, then go above the high threshold. The trigger stays asserted until the signal returns below the low threshold. The output of the trigger detection circuitry is the internal Analog Comparison Event signal, as shown in Figure 11-6.

Figure 11-6. Analog Edge Triggering with Hysteresis Rising Slope Example

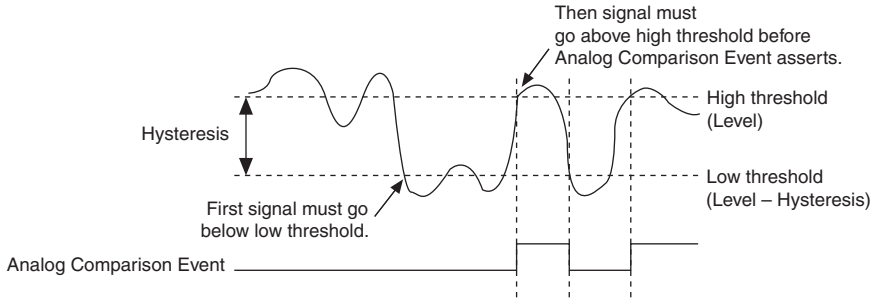

- Analog Edge Trigger with Hysteresis (Falling Slope)—When using hysteresis with a falling slope, you specify a trigger level and amount of hysteresis. The low threshold is the trigger level; the high threshold is the trigger level plus the hysteresis.

For the trigger to assert, the signal must first be above the high threshold, then go below the low threshold. The trigger stays asserted until the signal returns above the high threshold. The output of the trigger detection circuitry is the internal Analog Comparison Event signal, as shown in Figure 11-7.

Figure 11-7. Analog Edge Triggering with Hysteresis Falling Slope Example

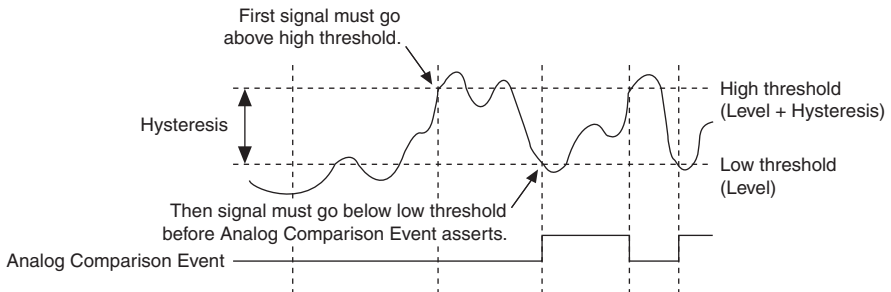

- **Analog Window Triggering**—An analog window trigger occurs when an analog signal either passes into (enters) or passes out of (leaves) a window defined by two voltage levels. Specify the levels by setting the window Top value and the window Bottom value.

Figure 11-8 demonstrates a trigger that asserts when the signal enters the window.

Figure 11-8. Analog Window Triggering Mode (Entering Window)

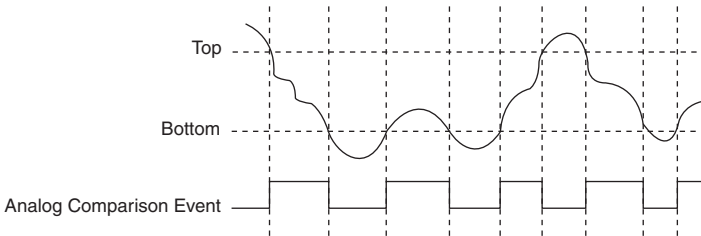

Analog Trigger Accuracy

The analog trigger circuitry compares the voltage of the trigger source to the output of programmable trigger DACs. When you configure the level (or the high and low limits in window trigger mode), the device adjusts the output of the trigger DACs. Refer to the device specifications to find the accuracy or resolution of these DACs, which also shows the accuracy or resolution of analog triggers.

To improve accuracy, do the following:

- Use an AI channel (with a small input range) instead of APFI <0,1> as your trigger source. The DAQ device does not amplify the APFI <0, 1> signals. When using an AI channel, the NI-PGIA amplifies the AI channel signal before driving the analog trigger circuitry. If you configure the AI channel to have a small input range, you can trigger on very small voltage changes in the input signal.
- Software-calibrate the analog trigger circuitry. The propagation delay from when a valid trigger condition is met to when the analog trigger circuitry emits the Analog Comparison Event may have an impact on your measurements if the trigger signal has a high slew rate. If you find these conditions have a noticeable impact on your measurements, you can perform software calibration on the analog trigger circuitry by configuring your task as normal and applying a known signal for your analog trigger. Comparing the observed results against the expected results, you can calculate the necessary offsets to apply in software to fine-tune the desired triggering behavior.

Device-Specific Information

This appendix contains device pinouts, specifications, cable and accessory choices, and other information for the following X Series devices:

- [NI 6320](#)
- [NI 6321/6341](#)
- [NI 6323/6343](#)
- [NI 6345/6355](#)
- [NI 6346](#)
- [NI 6349](#)
- [NI 6351/6361](#)
- [NI 6353/6363](#)
- [NI 6356/6366/6376/6386/6396](#)
- [NI 6358/6368/6378](#)
- [NI 6365](#)
- [NI 6374](#)
- [NI 6375](#)

To obtain documentation for devices not listed here, refer to ni.com/manuals.

NI 6320

The following sections contain information about the NI PCIe-6320 device.

NI 6320 Pinout

Figure A-1 shows the pinout of the NI PCIe-6320 device. For a detailed description of each signal, refer to the *I/O Connector Signal Descriptions* section of Chapter 3, *Connector and LED Information*.

Figure A-1. NI PCIe-6320 Pinout

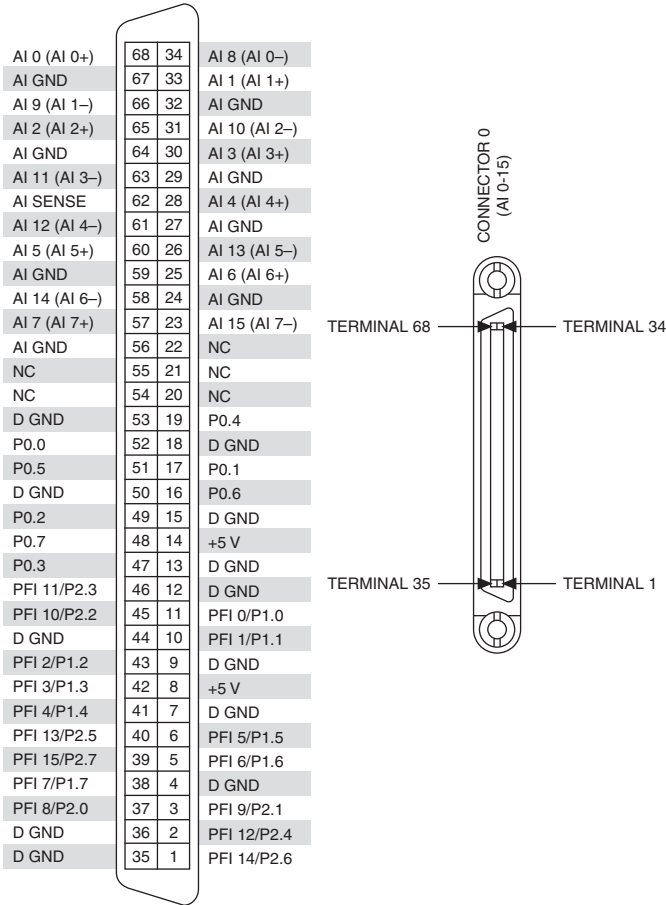



Note Refer to Table 7-9, *X Series PCI Express/PXI Express/USB Mass Termination/USB BNC Device Default NI-DAQmx Counter/Timer Pins*, for a list of the default NI-DAQmx counter/timer pins for this device. For more information about default NI-DAQmx counter inputs, refer to *Connecting Counter Signals* in the *NI-DAQmx Help* or the *LabVIEW Help*.

NI 6320 Device Specifications

Refer to the *NI 632x Device Specifications* for more detailed information about the NI 6320 device.

NI 6320 Accessory and Cabling Options

NI offers a variety of accessories and cables to use with your DAQ device. Refer to the *Cables and Accessories* section of Chapter 2, *DAQ System Overview*, for more information.

NI 6321/6341

The following sections contain information about the NI PCIe-6321, NI PCIe/PXIE-6341, and NI USB-6341 devices.

NI 6321/6341 Pinouts

Figure A-2 shows the pinout of the NI PCIe-6321 and NI PCIe/PXIE-6341 devices. For a detailed description of each signal, refer to the *I/O Connector Signal Descriptions* section of Chapter 3, *Connector and LED Information*.

Figure A-2. NI PCIe-6321 and NI PCIe/PXIE-6341 Pinout

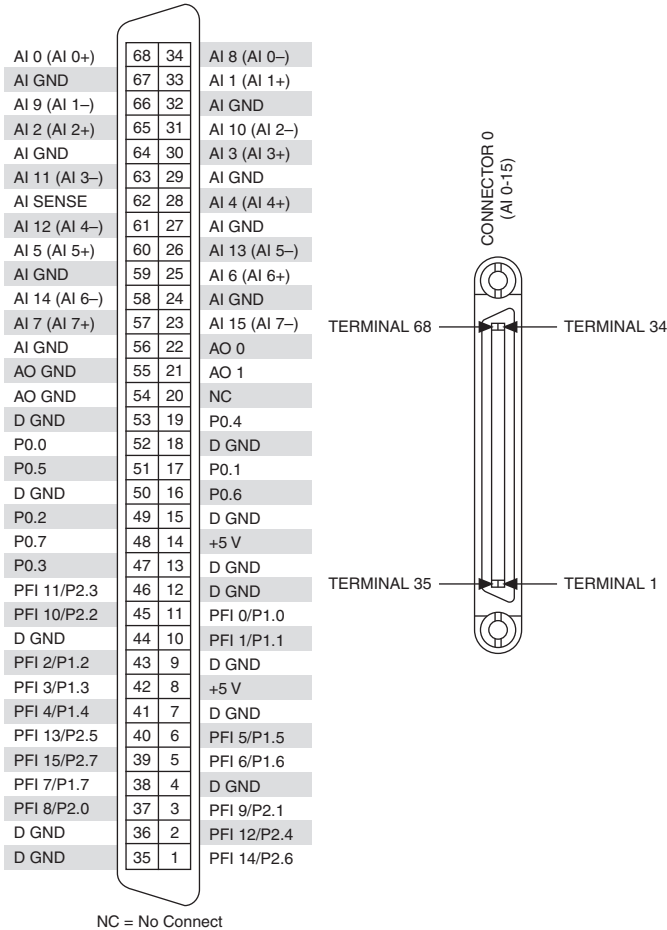



Note Refer to Table 7-9, *X Series PCI Express/PXI Express/USB Mass Termination/USB BNC Device Default NI-DAQmx Counter/Timer Pins*, for a list of the default NI-DAQmx counter/timer pins for this device. For more information about default NI-DAQmx counter inputs, refer to *Connecting Counter Signals* in the *NI-DAQmx Help* or the *LabVIEW Help*.

Figure A-3 shows the pinout of the NI USB-6341 Screw Terminal. For a detailed description of each signal, refer to the *I/O Connector Signal Descriptions* section of Chapter 3, *Connector and LED Information*.

Figure A-3. NI USB-6341 Screw Terminal Pinout

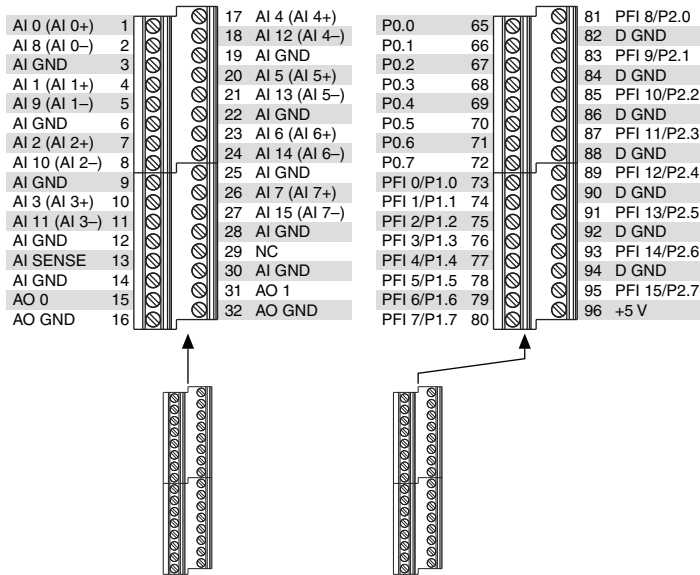

NC = No Connect



Note Refer to Table 7-10, *X Series USB Screw Terminal Device Default NI-DAQmx Counter/Timer Pins*, for a list of the default NI-DAQmx counter/timer pins for this device. For more information about default NI-DAQmx counter inputs, refer to *Connecting Counter Signals* in the *NI-DAQmx Help* or the *LabVIEW Help*.

Figure A-4 shows the pinout of the NI USB-6341 BNC. For a detailed description of each signal, refer to the *I/O Connector Signal Descriptions* section of Chapter 3, *Connector and LED Information*.

Figure A-4. NI USB-6341 BNC Pinout

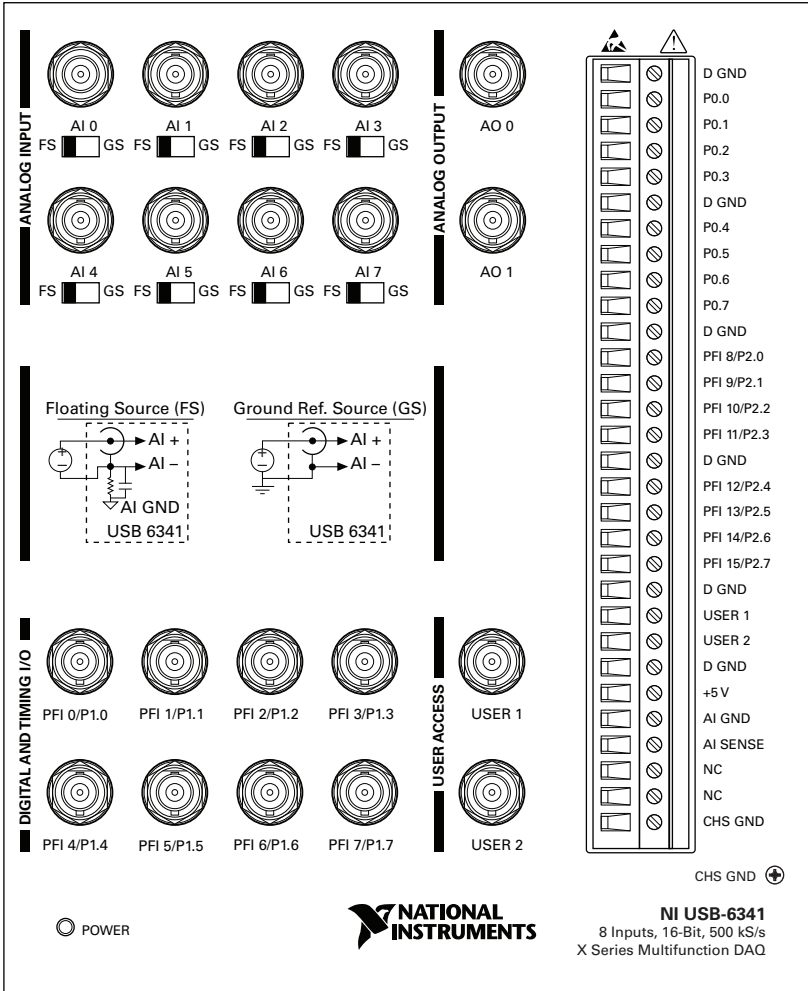

Refer to Table 7-9, *X Series PCI Express/PXI Express/USB Mass Termination/USB BNC Device Default NI-DAQmx Counter/Timer Pins*, for a list of the default NI-DAQmx counter/timer pins for this device. For more information about default NI-DAQmx counter inputs, refer to *Connecting Counter Signals* in the *NI-DAQmx Help* or the *LabVIEW Help*.

NI 6321/6341 Device Specifications

Refer to the following documents for more detailed information about your device:

- **PCIe-6321**—*PCIe-6321 Specifications*
- **PCIe-6341**—*PCIe-6341 Specifications*
- **PXIe-6341**—*PXIe-6341 Specifications*
- **USB-6341**—*USB-6341 Specifications*

NI 6321/6341 Accessory and Cabling Options

NI offers a variety of accessories and cables to use with your DAQ device. Refer to the [Cables and Accessories](#) section of Chapter 2, [DAQ System Overview](#), for more information.

NI 6323/6343

The following sections contain information about the NI PCIe-6323, NI PCIe-6343, and NI USB-6343 devices.

NI 6323/6343 Pinouts

Figure A-5 shows the pinout of the NI PCIe-6323/6343. The I/O signals appear on two 68-pin connectors. For a detailed description of each signal, refer to the *I/O Connector Signal Descriptions* section of Chapter 3, *Connector and LED Information*.

Figure A-5. NI PCIe-6323/6343 Pinout

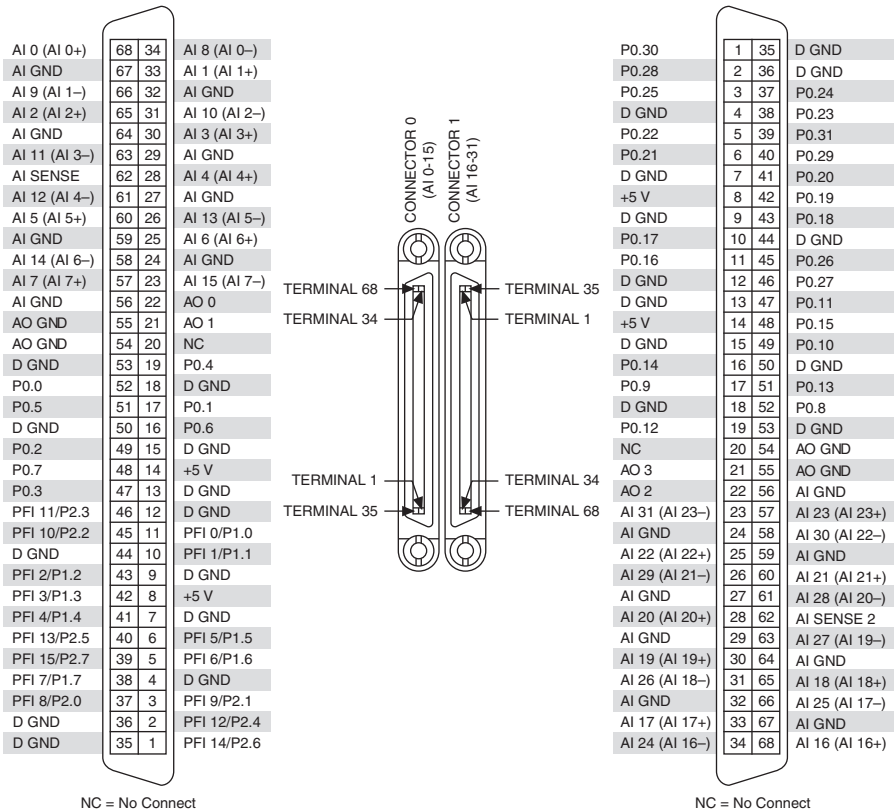

Note Refer to Table 7-9, *X Series PCI Express/PXI Express/USB Mass Termination/USB BNC Device Default NI-DAQmx Counter/Timer Pins*, for a list of the default NI-DAQmx counter/timer pins for this device. For more information about default NI-DAQmx counter inputs, refer to *Connecting Counter Signals* in the *NI-DAQmx Help* or the *LabVIEW Help*.

Figure A-6 shows the pinout of the NI USB-6343 Screw Terminal. For a detailed description of each signal, refer to the *I/O Connector Signal Descriptions* section of Chapter 3, *Connector and LED Information*.

Figure A-6. NI USB-6343 Screw Terminal Pinout

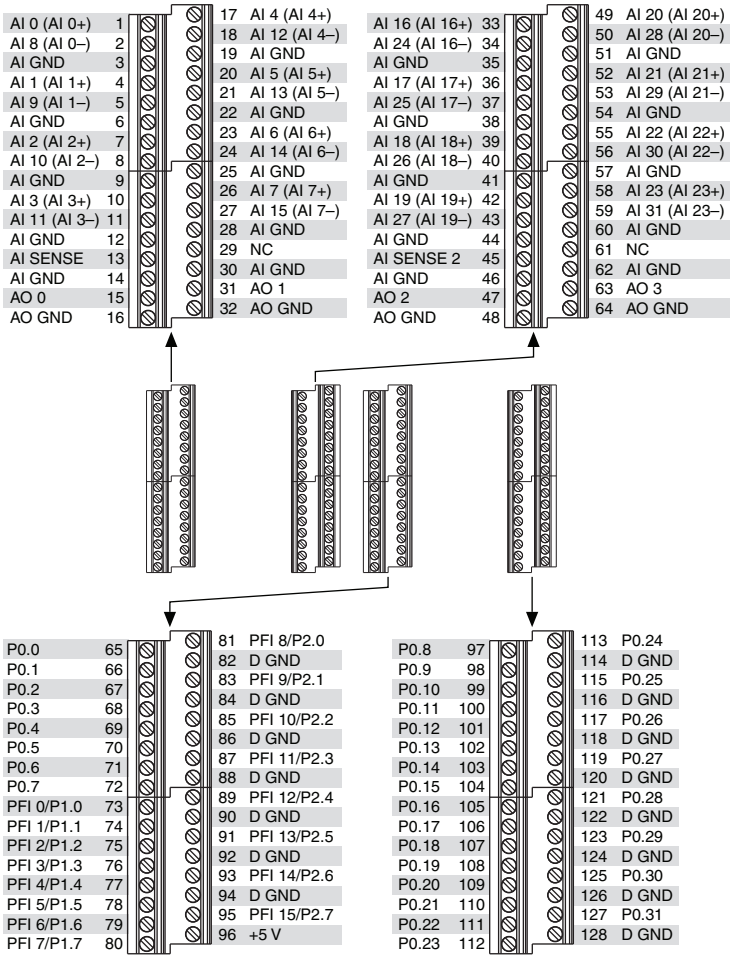

NC = No Connect

Figure A-7 shows the pinout of the NI USB-6343 BNC. For a detailed description of each signal, refer to the *I/O Connector Signal Descriptions* section of Chapter 3, *Connector and LED Information*.

Figure A-7. NI USB-6343 BNC Pinout

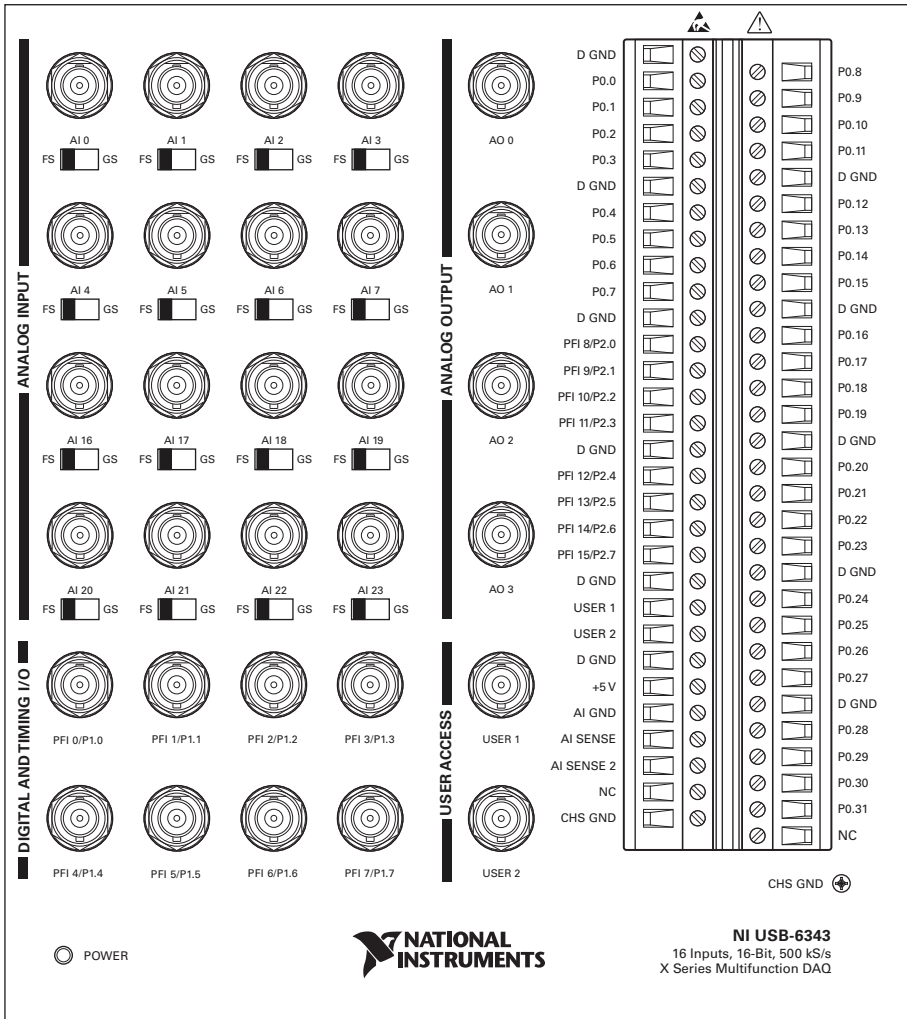

Refer to Table 7-9, *X Series PCI Express/PXI Express/USB Mass Termination/USB BNC Device Default NI-DAQmx Counter/Timer Pins*, for a list of the default NI-DAQmx counter/timer pins for this device. For more information about default NI-DAQmx counter inputs, refer to *Connecting Counter Signals* in the *NI-DAQmx Help* or the *LabVIEW Help*.

NI 6323/6343 Device Specifications

Refer to the following documents for more detailed information about your device:

- **PCIe-6323**—*NI 6323 Device Specifications*
- **PCIe-6343**—*PCIe-6343 Specifications*
- **USB-6343**—*USB-6343 Specifications*

NI 6323/6343 Accessory and Cabling Options

NI offers a variety of accessories and cables to use with your DAQ device. Refer to the [Cables and Accessories](#) section of Chapter 2, [DAQ System Overview](#), for more information.

NI 6345/6355

The following sections contain information about the NI PXIe-6345 and NI PXIe-6355 devices.

NI 6345/6355 Pinouts

Figure A-8 shows the pinout of the NI PXIe-6345 and NI PXIe-6355. The I/O signals appear on two 68-pin connectors. For a detailed description of each signal, refer to the *I/O Connector Signal Descriptions* section of Chapter 3, *Connector and LED Information*.

Figure A-8. NI PXIe-6345/6355 Pinout

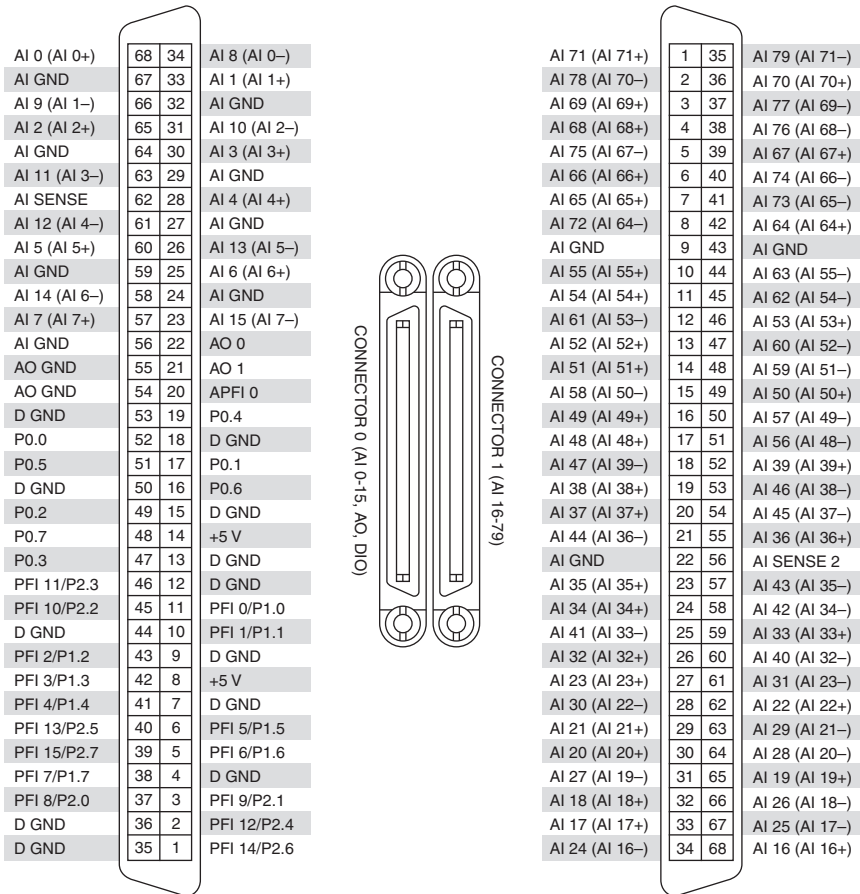



Note Refer to Table 7-9, *X Series PCI Express/PXI Express/USB Mass Termination/USB BNC Device Default NI-DAQmx Counter/Timer Pins*, for a list of the default NI-DAQmx counter/timer pins for this device. For more information about default NI-DAQmx counter inputs, refer to *Connecting Counter Signals* in the *NI-DAQmx Help* or the *LabVIEW Help*.

NI 6345/6355 Device Specifications

Refer to the *NI 6345 Device Specifications* for more detailed information about the NI 6345 device. Refer to the *NI 6355 Device Specifications* for more detailed information about the NI 6355 device.

NI 6345/6355 Accessory and Cabling Options

NI offers a variety of accessories and cables to use with your DAQ device. Refer to the *Cables and Accessories* section of Chapter 2, *DAQ System Overview*, for more information.

NI 6346

The following sections contain information about the NI PCIe-6346.

NI 6346 Pinout

Figure A-9 shows the pinout of the NI PCIe-6346. The I/O signals appear on one 68-pin connector. For a detailed description of each signal, refer to the *I/O Connector Signal Descriptions* section of Chapter 3, *Connector and LED Information*.

Figure A-9. NI PCIe-6346 Pinout

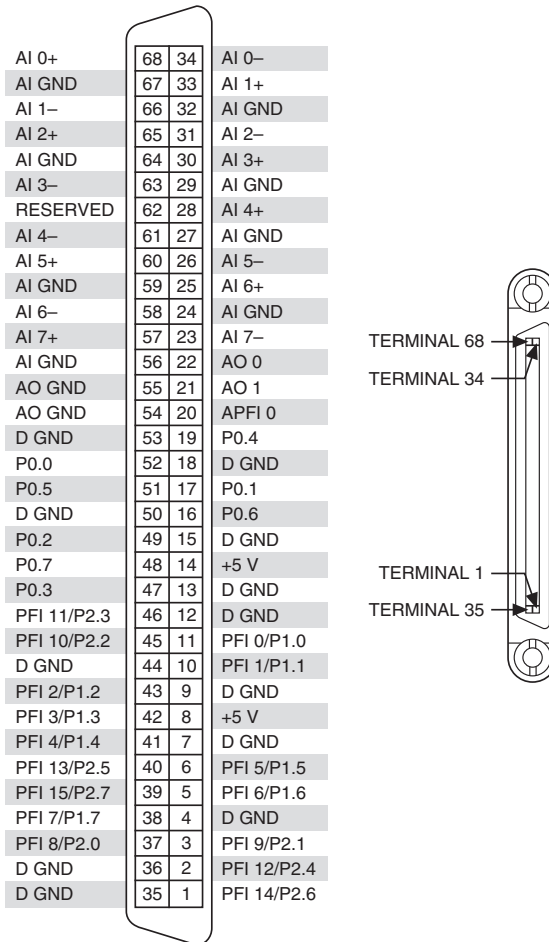

Figure A-10. NI USB 6346 Screw Terminal Pinout

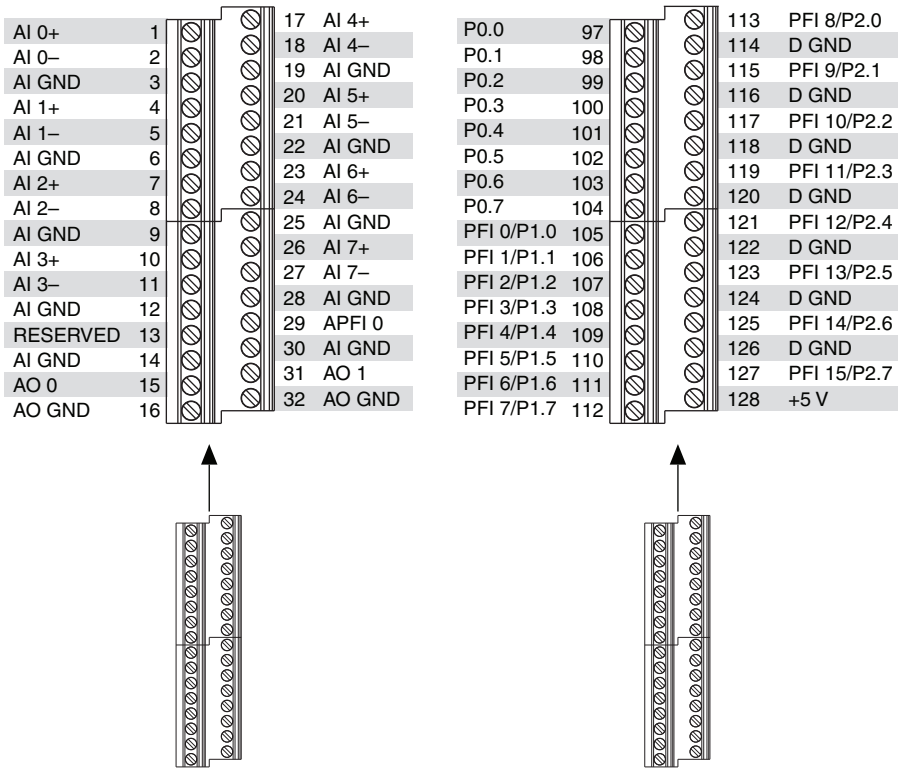
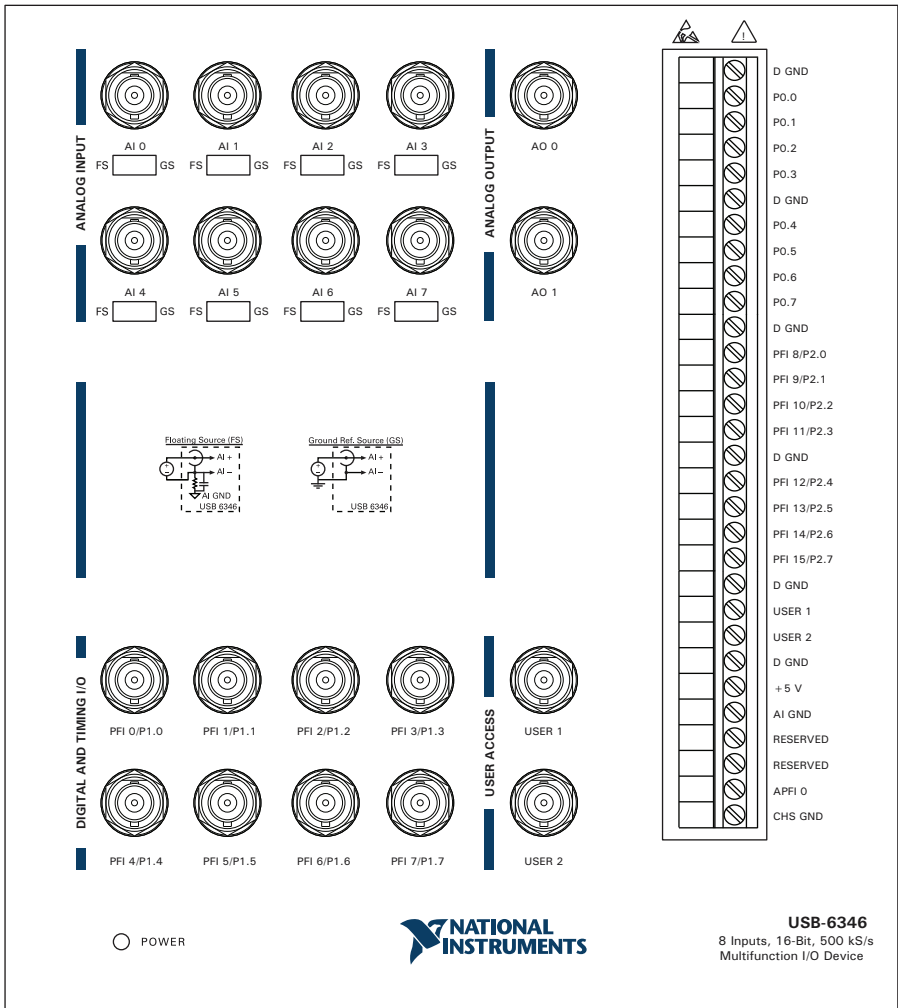

Figure A-11. NI USB 6346 BNC Pinout



Note Refer to Table 7-9, *X Series PCI Express/PXI Express/USB Mass Termination/USB BNC Device Default NI-DAQmx Counter/Timer Pins*, for a list of the default NI-DAQmx counter/timer pins for this device. For more information about default NI-DAQmx counter inputs, refer to *Connecting Counter Signals* in the *NI-DAQmx Help* or the *LabVIEW Help*.

NI 6346 Device Specifications

Refer to the *NI 6346 Device Specifications* for more detailed information about the NI 6346 device.

NI 6346 Accessory and Cabling Options

NI offers a variety of accessories and cables to use with your DAQ device. Refer to the [Cables and Accessories](#) section of Chapter 2, *DAQ System Overview*, for more information.

NI 6349

The following sections contain information about the NI PXIe-6349.

NI 6349 Pinouts

Figure A-12 shows the pinout of the NI PXIe-6349. The I/O signals appear on two 68-pin connectors. For a detailed description of each signal, refer to the *I/O Connector Signal Descriptions* section of Chapter 3, *Connector and LED Information*.

Figure A-12. NI PXIe-6349 Pinout

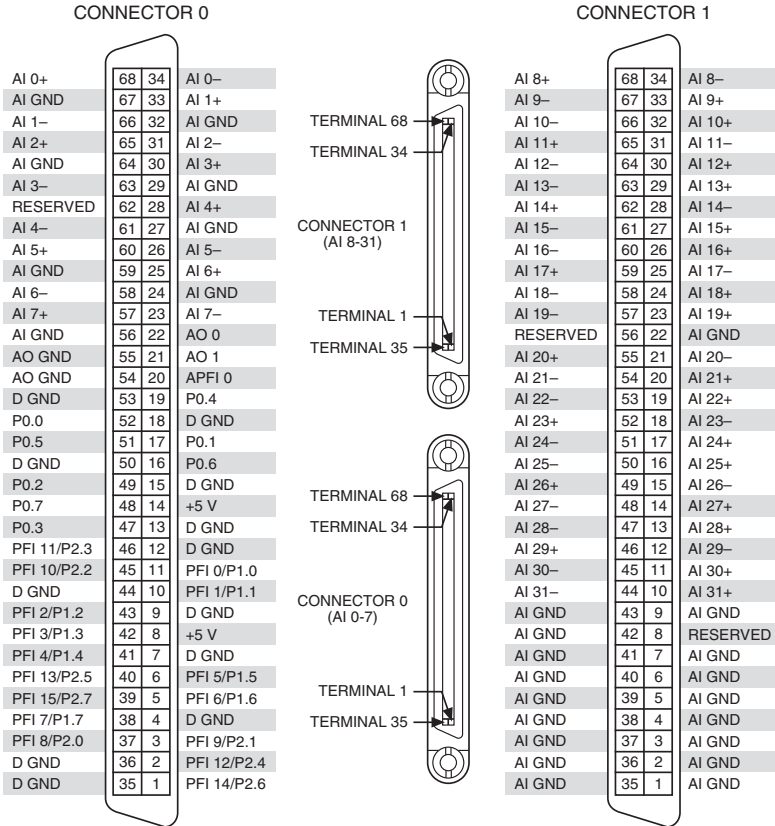
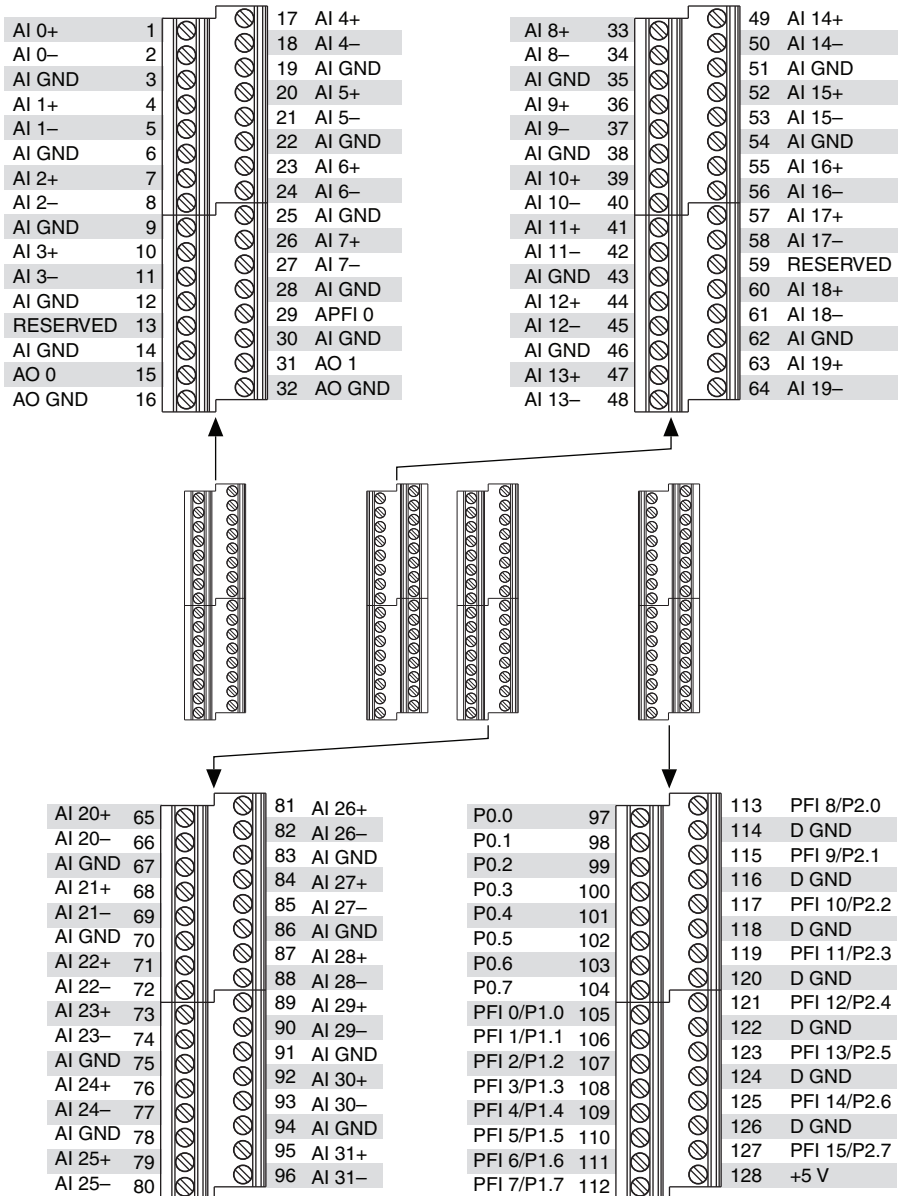

Figure A-13. NI USB-6349 Screw Terminal Pinout



Note Refer to Table 7-9, *X Series PCI Express/PXI Express/USB Mass Termination/USB BNC Device Default NI-DAQmx Counter/Timer Pins*, for a list of

the default NI-DAQmx counter/timer pins for this device. For more information about default NI-DAQmx counter inputs, refer to *Connecting Counter Signals* in the *NI-DAQmx Help* or the *LabVIEW Help*.

NI 6349 Device Specifications

Refer to the *NI 6349 Device Specifications* for more detailed information about the NI 6349 device.

NI 6349 Accessory and Cabling Options

NI offers a variety of accessories and cables to use with your DAQ device. Refer to the [Cables and Accessories](#) section of Chapter 2, [DAQ System Overview](#), for more information.

NI 6351/6361

The following sections contain information about the NI PCIe 6351, NI USB-6351 Screw Terminal, NI PCIe/PXIe-6361, and NI USB-6361 devices.

NI 6351/6361 Pinout

Figure A-14 shows the pinout of the NI PCIe-6351 and NI PCIe/PXIe-6361. For a detailed description of each signal, refer to the [I/O Connector Signal Descriptions](#) section of Chapter 3, [Connector and LED Information](#).

Figure A-14. NI PCIe-6351 and NI PCIe/PXIe-6361 Pinout

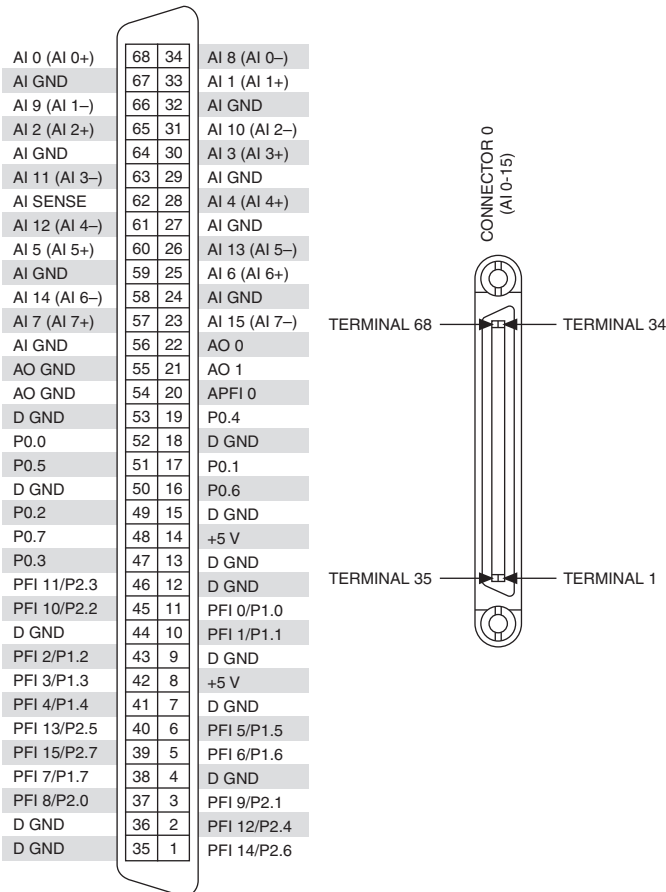



Note Refer to Table 7-9, *X Series PCI Express/PXI Express/USB Mass Termination/USB BNC Device Default NI-DAQmx Counter/Timer Pins*, for a list of the default NI-DAQmx counter/timer pins for this device. For more information about default NI-DAQmx counter inputs, refer to *Connecting Counter Signals* in the *NI-DAQmx Help* or the *LabVIEW Help*.

Figure A-15 shows the pinout of the NI USB-6351/6361 Screw Terminal. For a detailed description of each signal, refer to the *I/O Connector Signal Descriptions* section of Chapter 3, *Connector and LED Information*.

Figure A-15. NI USB-6351/6361 Screw Terminal Pinout

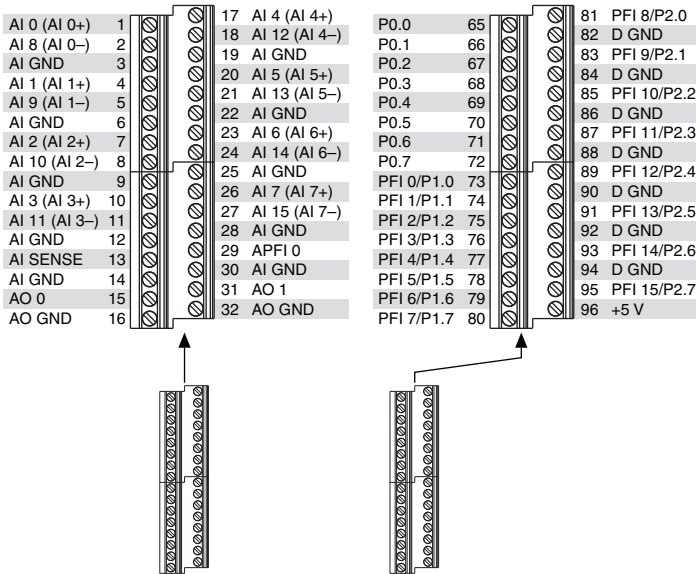

Note Refer to Table 7-10, *X Series USB Screw Terminal Device Default NI-DAQmx Counter/Timer Pins*, for a list of the default NI-DAQmx counter/timer pins for this device. For more information about default NI-DAQmx counter inputs, refer to *Connecting Counter Signals* in the *NI-DAQmx Help* or the *LabVIEW Help*.

Figure A-16 shows the pinout of the NI USB-6361 Mass Termination. For a detailed description of each signal, refer to the *I/O Connector Signal Descriptions* section of Chapter 3, *Connector and LED Information*.

Figure A-16. NI USB-6361 Mass Termination Pinout

AI 0 (AI 0+)	68	34	AI 8 (AI 0-)
AI GND	67	33	AI 1 (AI 1+)
AI 9 (AI 1-)	66	32	AI GND
AI 2 (AI 2+)	65	31	AI 10 (AI 2-)
AI GND	64	30	AI 3 (AI 3+)
AI 11 (AI 3-)	63	29	AI GND
AI SENSE	62	28	AI 4 (AI 4+)
AI 12 (AI 4-)	61	27	AI GND
AI 5 (AI 5+)	60	26	AI 13 (AI 5-)
AI GND	59	25	AI 6 (AI 6+)
AI 14 (AI 6-)	58	24	AI GND
AI 7 (AI 7+)	57	23	AI 15 (AI 7-)
AI GND	56	22	AO 0
AO GND	55	21	AO 1
AO GND	54	20	APFI 0
D GND	53	19	P0.4
P0.0	52	18	D GND
P0.5	51	17	P0.1
D GND	50	16	P0.6
P0.2	49	15	D GND
P0.7	48	14	+5 V
P0.3	47	13	D GND
PFI 11/P2.3	46	12	D GND
PFI 10/P2.2	45	11	PFI 0/P1.0
D GND	44	10	PFI 1/P1.1
PFI 2/P1.2	43	9	D GND
PFI 3/P1.3	42	8	+5 V
PFI 4/P1.4	41	7	D GND
PFI 13/P2.5	40	6	PFI 5/P1.5
PFI 15/P2.7	39	5	PFI 6/P1.6
PFI 7/P1.7	38	4	D GND
PFI 8/P2.0	37	3	PFI 9/P2.1
D GND	36	2	PFI 12/P2.4
D GND	35	1	PFI 14/P2.6

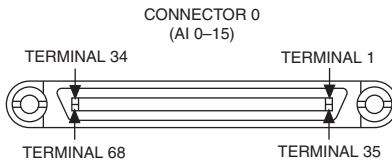



Note Refer to Table 7-9, *X Series PCI Express/PXI Express/USB Mass Termination/USB BNC Device Default NI-DAQmx Counter/Timer Pins*, for a list of the default NI-DAQmx counter/timer pins for this device. For more information about default NI-DAQmx counter inputs, refer to *Connecting Counter Signals* in the *NI-DAQmx Help* or the *LabVIEW Help*.

Figure A-17 shows the pinout of the NI USB-6361 BNC. For a detailed description of each signal, refer to the *I/O Connector Signal Descriptions* section of Chapter 3, *Connector and LED Information*.

Figure A-17. NI USB-6361 BNC Pinout

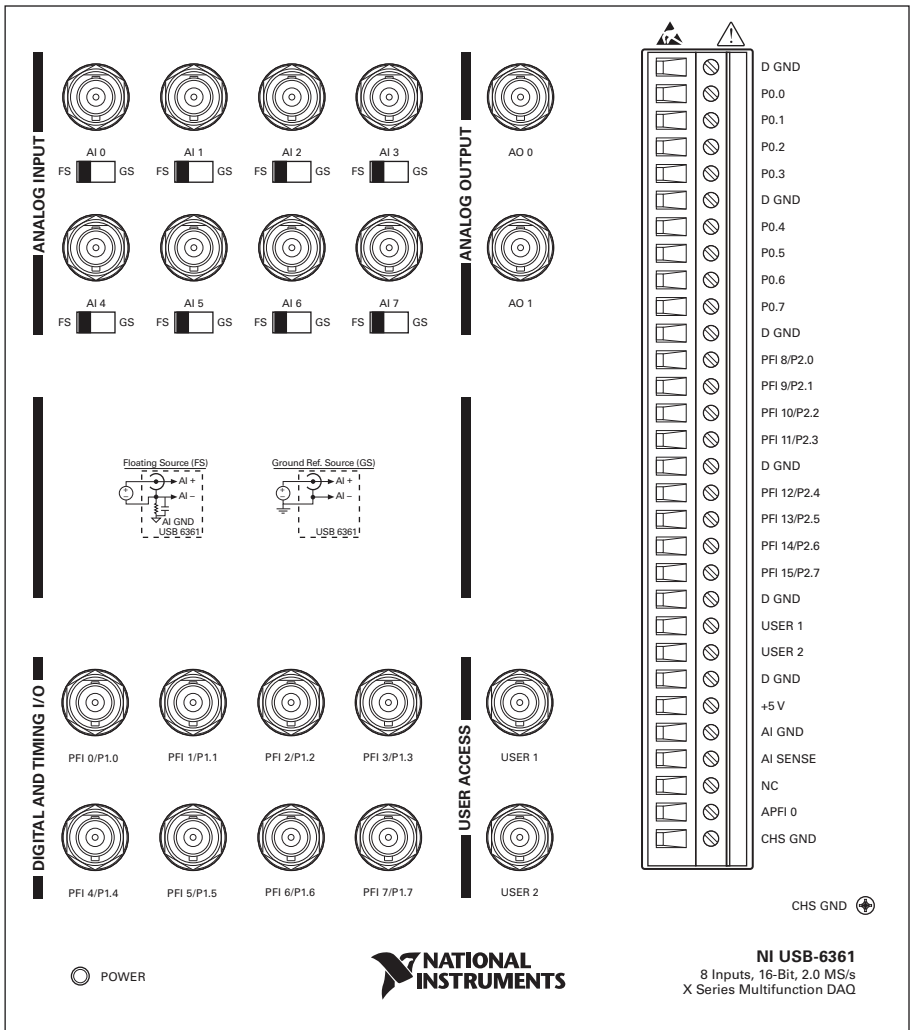

Refer to Table 7-9, *X Series PCI Express/PXI Express/USB Mass Termination/USB BNC Device Default NI-DAQmx Counter/Timer Pins*, for a list of the default NI-DAQmx counter/timer pins for this device. For more information about default NI-DAQmx counter inputs, refer to *Connecting Counter Signals* in the *NI-DAQmx Help* or the *LabVIEW Help*.

NI 6351/6361 Device Specifications

Refer to the *NI 6351 Device Specifications* for more detailed information about the NI 6351 device. Refer to the *NI 6361 Device Specifications* for more detailed information about the NI 6361 device.

NI 6351/6361 Accessory and Cabling Options

NI offers a variety of accessories and cables to use with your DAQ device. Refer to the [Cables and Accessories](#) section of Chapter 2, *DAQ System Overview*, for more information.

NI 6353/6363

The following sections contain information about the NI PCIe-6353, NI USB-6353 Screw Terminal, NI PCIe/PXIe-6363, and NI USB-6363 devices.

NI 6353/6363 Pinouts

Figure A-18 shows the pinout of the NI PCIe-6353 and NI PCIe/PXIe-6363. The I/O signals appear on two 68-pin connectors. For a detailed description of each signal, refer to the [I/O Connector Signal Descriptions](#) section of Chapter 3, [Connector and LED Information](#).

Figure A-18. NI PCIe-6353 and NI PCIe/PXIe-6363 Pinout

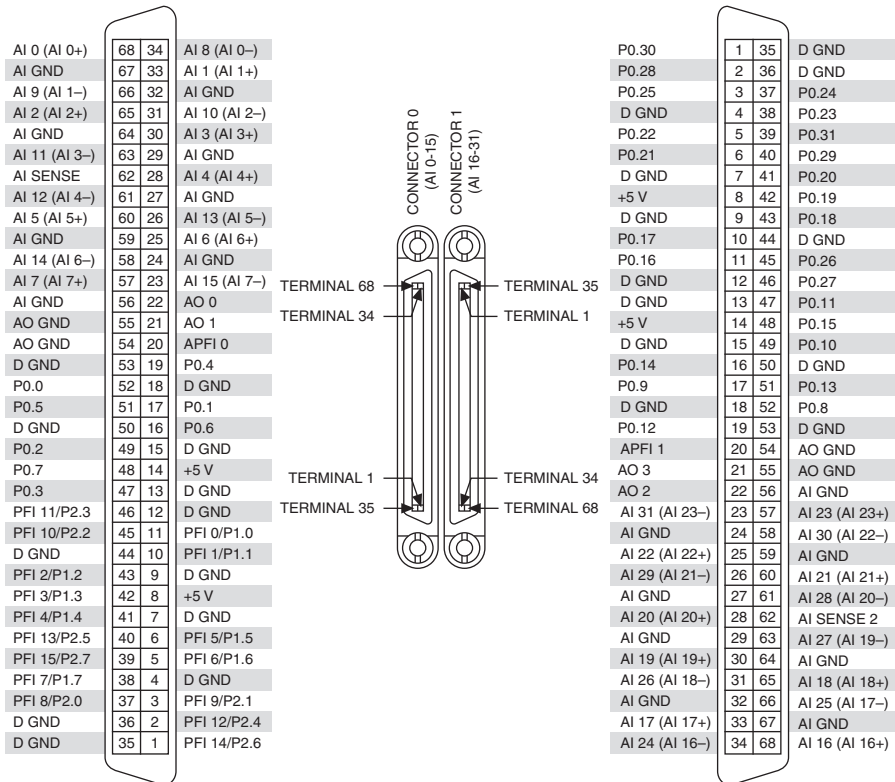

Note Refer to Table 7-9, *X Series PCI Express/PXI Express/USB Mass Termination/USB BNC Device Default NI-DAQmx Counter/Timer Pins*, for a list of the default NI-DAQmx counter/timer pins for this device. For more information about default NI-DAQmx counter inputs, refer to *Connecting Counter Signals* in the *NI-DAQmx Help* or the *LabVIEW Help*.

Figure A-19 shows the pinout of the NI USB-6363 Mass Termination. For a detailed description of each signal, refer to the *I/O Connector Signal Descriptions* section of Chapter 3, *Connector and LED Information*.

Figure A-19. NI USB-6363 Mass Termination Pinout

AI 0 (AI 0+)	68	34	AI 8 (AI 0-)
AI GND	67	33	AI 1 (AI 1+)
AI 9 (AI 1-)	66	32	AI GND
AI 2 (AI 2+)	65	31	AI 10 (AI 2-)
AI GND	64	30	AI 3 (AI 3+)
AI 11 (AI 3-)	63	29	AI GND
AI SENSE	62	28	AI 4 (AI 4+)
AI 12 (AI 4-)	61	27	AI GND
AI 5 (AI 5+)	60	26	AI 13 (AI 5-)
AI GND	59	25	AI 6 (AI 6+)
AI 14 (AI 6-)	58	24	AI GND
AI 7 (AI 7+)	57	23	AI 15 (AI 7-)
AI GND	56	22	AO 0
AO GND	55	21	AO 1
AO GND	54	20	APFI 0
D GND	53	19	P0.4
P0.0	52	18	D GND
P0.5	51	17	P0.1
D GND	50	16	P0.6
P0.2	49	15	D GND
P0.7	48	14	+5 V
P0.3	47	13	D GND
PFI 11/P2.3	46	12	D GND
PFI 10/P2.2	45	11	PFI 0/P1.0
D GND	44	10	PFI 1/P1.1
PFI 2/P1.2	43	9	D GND
PFI 3/P1.3	42	8	+5 V
PFI 4/P1.4	41	7	D GND
PFI 13/P2.5	40	6	PFI 5/P1.5
PFI 15/P2.7	39	5	PFI 6/P1.6
PFI 7/P1.7	38	4	D GND
PFI 8/P2.0	37	3	PFI 9/P2.1
D GND	36	2	PFI 12/P2.4
D GND	35	1	PFI 14/P2.6
AI 16 (AI 16+)	68	34	AI 24 (AI 16-)
AI GND	67	33	AI 17 (AI 17+)
AI 25 (AI 17-)	66	32	AI GND
AI 18 (AI 18+)	65	31	AI 26 (AI 18-)
AI GND	64	30	AI 19 (AI 19+)
AI 27 (AI 19-)	63	29	AI GND
AI SENSE 2	62	28	AI 20 (AI 20+)
AI 28 (AI 20-)	61	27	AI GND
AI 21 (AI 21+)	60	26	AI 29 (AI 21-)
AI GND	59	25	AI 22 (AI 22+)
AI 30 (AI 22-)	58	24	AI GND
AI 23 (AI 23+)	57	23	AI 31 (AI 23-)
AI GND	56	22	AO 2
AO GND	55	21	AO 3
AO GND	54	20	APFI 1
D GND	53	19	P0.12
P0.8	52	18	D GND
P0.13	51	17	P0.9
D GND	50	16	P0.14
P0.10	49	15	D GND
P0.15	48	14	+5 V
P0.11	47	13	D GND
P0.27	46	12	D GND
P0.26	45	11	P0.16
D GND	44	10	P0.17
P0.18	43	9	D GND
P0.19	42	8	+5 V
P0.20	41	7	D GND
P0.29	40	6	P0.21
P0.31	39	5	P0.22
P0.23	38	4	D GND
P0.24	37	3	P0.25
D GND	36	2	P0.28
D GND	35	1	P0.30

CONNECTOR 0
(AI 0-15)

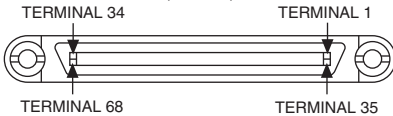

CONNECTOR 1
(AI 16-31)

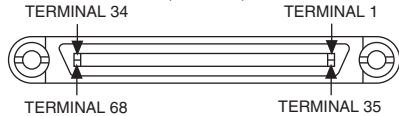



Note Refer to Table 7-9, *X Series PCI Express/PXI Express/USB Mass Termination/USB BNC Device Default NI-DAQmx Counter/Timer Pins*, for a list of the default NI-DAQmx counter/timer pins for this device. For more information about default NI-DAQmx counter inputs, refer to *Connecting Counter Signals* in the *NI-DAQmx Help* or the *LabVIEW Help*.

Figure A-20 shows the pinout of the NI USB-6353/6363 Screw Terminal. For a detailed description of each signal, refer to the *I/O Connector Signal Descriptions* section of Chapter 3, *Connector and LED Information*.

Figure A-20. NI USB-6353/6363 Screw Terminal Pinout

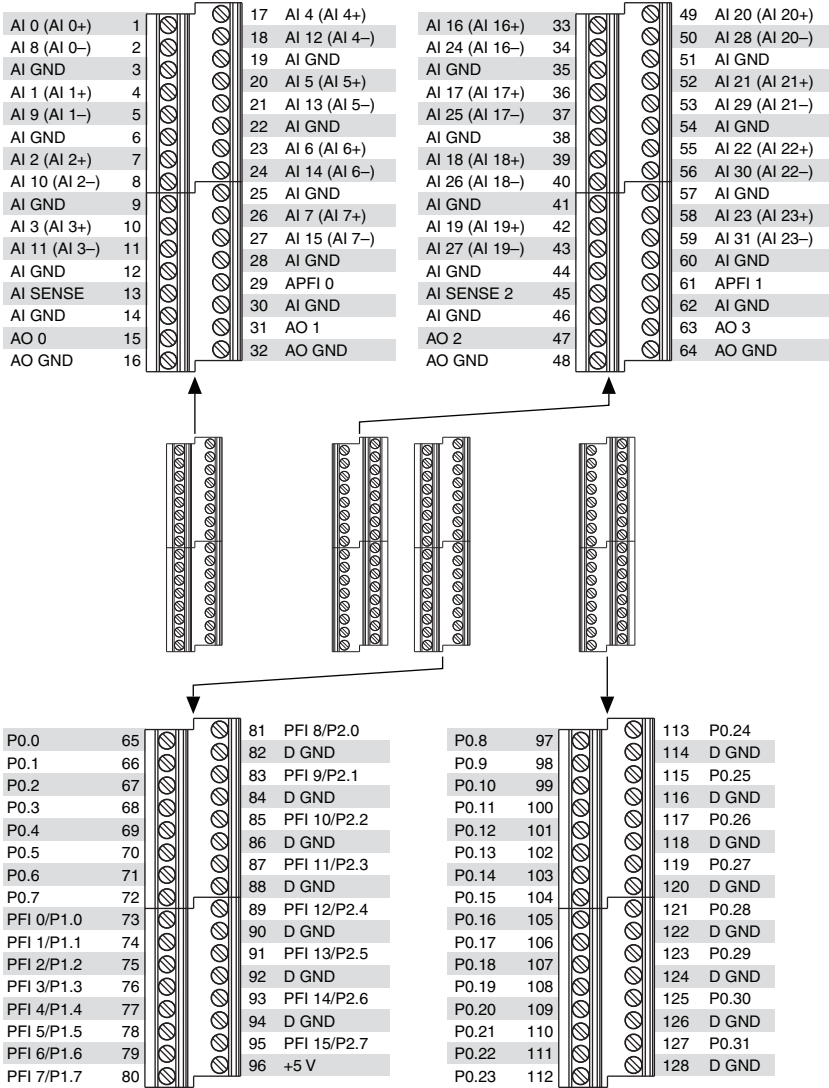



Note Refer to Table 7-10, *X Series USB Screw Terminal Device Default NI-DAQmx Counter/Timer Pins*, for a list of the default NI-DAQmx counter/timer pins for this device. For more information about default NI-DAQmx counter inputs, refer to *Connecting Counter Signals* in the *NI-DAQmx Help* or the *LabVIEW Help*.

Figure A-21 shows the pinout of the NI USB-6363 BNC. For a detailed description of each signal, refer to the *I/O Connector Signal Descriptions* section of Chapter 3, *Connector and LED Information*.

Figure A-21. NI USB-6363 Pinout

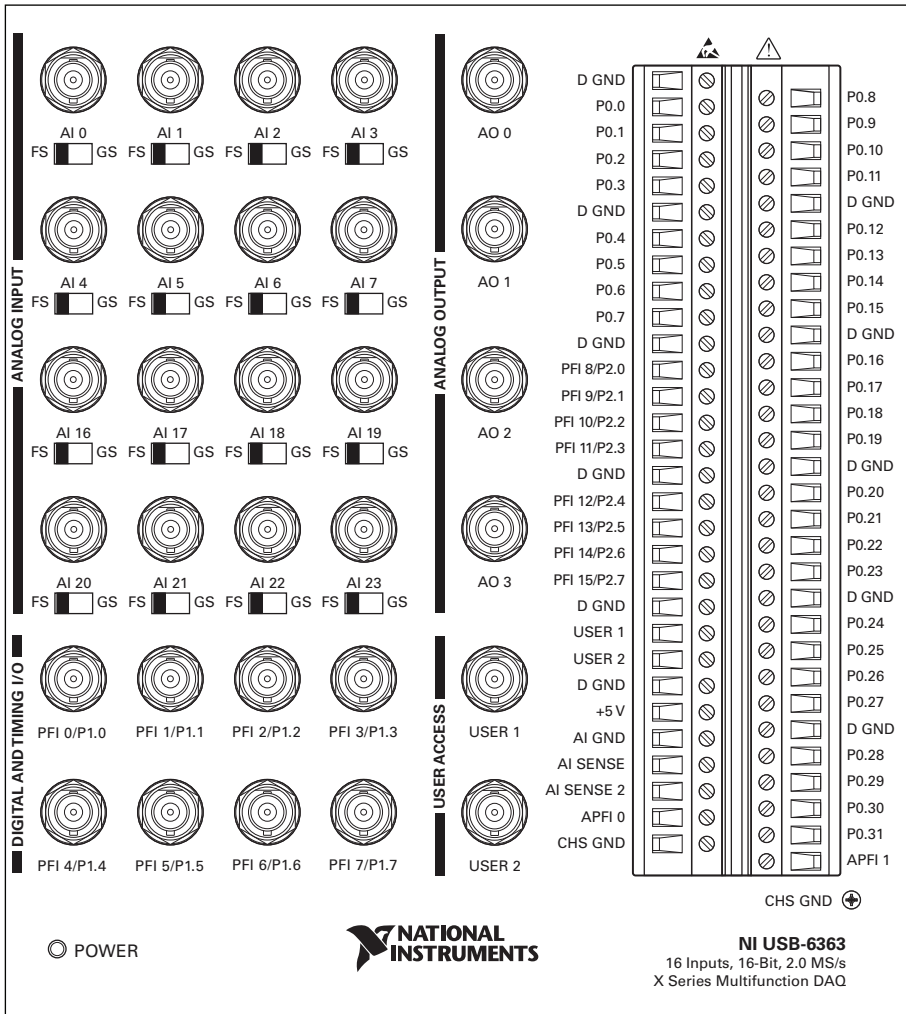

Refer to Table 7-9, *X Series PCI Express/PXI Express/USB Mass Termination/USB BNC Device Default NI-DAQmx Counter/Timer Pins*, for a list of the default NI-DAQmx counter/timer pins for this device. For more information about default NI-DAQmx counter inputs, refer to *Connecting Counter Signals* in the *NI-DAQmx Help* or the *LabVIEW Help*.

NI 6353/6363 Device Specifications

Refer to the following documents for more detailed information about your device:

- **PCIe-6363**—*PCIe-6363 Specifications*
- **PXIe-6363**—*PXIe-6363 Specifications*
- **USB-6363**—*USB-6363 Specifications*

NI 6353/6363 Accessory and Cabling Options

NI offers a variety of accessories and cables to use with your DAQ device. Refer to the *Cables and Accessories* section of Chapter 2, *DAQ System Overview*, for more information.

NI 6356/6366/6376/6386/6396

The following sections contain information about the NI PXIe-6356, NI USB-6356, NI PXIe-6366, NI USB-6366, NI PCIe-6376, NI PXIe-6376, NI PXIe-6386, and NI PXIe-6396 devices.



Note (NI PXIe-6386/6396 Devices) PXIe-6386 and PXIe-6396 devices differ in several ways from other SMIO devices. For more information about these considerations, go to ni.com/info and enter the Info Code `smio14ms`.

NI 6356/6366/6376/6386/6396 Pinouts

Figure A-22 shows the pinout of the NI PCIe-6376 and PXIe-6356/6366/6376/6386/6396. For a detailed description of each signal, refer to the *I/O Connector Signal Descriptions* section of Chapter 3, *Connector and LED Information*.

Figure A-22. NI PXIe-6356/6366/6386/6396 and PCIe/PXIe-6376 Pinout

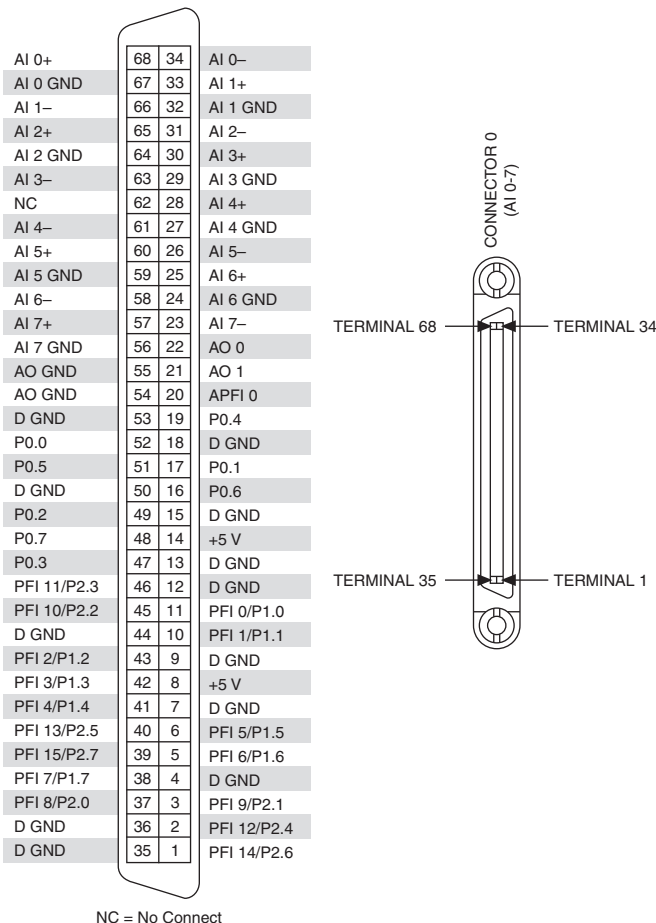



Note Refer to Table 7-9, *X Series PCI Express/PXI Express/USB Mass Termination/USB BNC Device Default NI-DAQmx Counter/Timer Pins*, for a list of the default NI-DAQmx counter/timer pins for this device. For more information about default NI-DAQmx counter inputs, refer to *Connecting Counter Signals* in the *NI-DAQmx Help* or the *LabVIEW Help*.

Figure A-23 shows the pinout of the NI USB-6366 Mass Termination. For a detailed description of each signal, refer to the *I/O Connector Signal Descriptions* section of Chapter 3, *Connector and LED Information*.

Figure A-23. NI USB-6366 Mass Termination Pinout

AI 0+	68	34	AI 0-
AI 0 GND	67	33	AI 1+
AI 1-	66	32	AI 1 GND
AI 2+	65	31	AI 2-
AI 2 GND	64	30	AI 3+
AI 3-	63	29	AI 3 GND
NC	62	28	AI 4+
AI 4-	61	27	AI 4 GND
AI 5+	60	26	AI 5-
AI 5 GND	59	25	AI 6+
AI 6-	58	24	AI 6 GND
AI 7+	57	23	AI 7-
AI 7 GND	56	22	AO 0
AO GND	55	21	AO 1
AO GND	54	20	APFI 0
D GND	53	19	P0.4
P0.0	52	18	D GND
P0.5	51	17	P0.1
D GND	50	16	P0.6
P0.2	49	15	D GND
P0.7	48	14	+5 V
P0.3	47	13	D GND
PFI 11/P2.3	46	12	D GND
PFI 10/P2.2	45	11	PFI 0/P1.0
D GND	44	10	PFI 1/P1.1
PFI 2/P1.2	43	9	D GND
PFI 3/P1.3	42	8	+5 V
PFI 4/P1.4	41	7	D GND
PFI 13/P2.5	40	6	PFI 5/P1.5
PFI 15/P2.7	39	5	PFI 6/P1.6
PFI 7/P1.7	38	4	D GND
PFI 8/P2.0	37	3	PFI 9/P2.1
D GND	36	2	PFI 12/P2.4
D GND	35	1	PFI 14/P2.6

NC = No Connect

CONNECTOR 0
(AI 0-7)

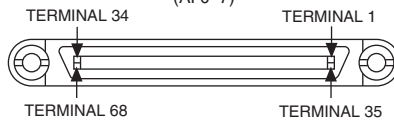



Note Refer to Table 7-9, *X Series PCI Express/PXI Express/USB Mass Termination/USB BNC Device Default NI-DAQmx Counter/Timer Pins*, for a list of the default NI-DAQmx counter/timer pins for this device. For more information about default NI-DAQmx counter inputs, refer to *Connecting Counter Signals* in the *NI-DAQmx Help* or the *LabVIEW Help*.

Figure A-24 shows the pinout of the NI USB-6356/6366 Screw Terminal. For a detailed description of each signal, refer to the *I/O Connector Signal Descriptions* section of Chapter 3, *Connector and LED Information*.

Figure A-24. NI USB-6356/6366 Screw Terminal Pinout

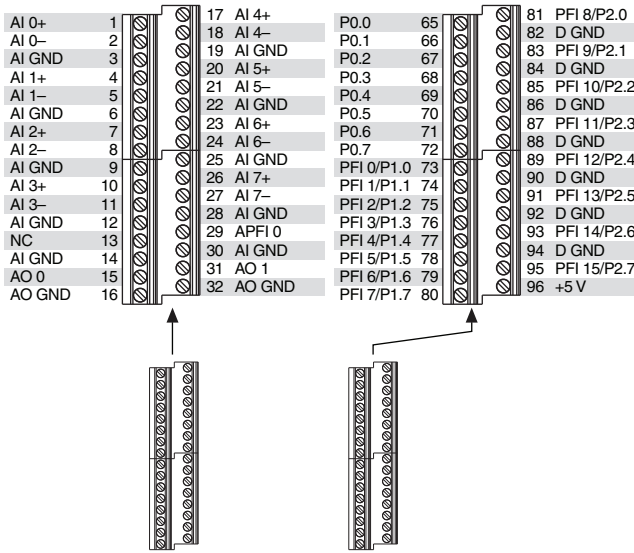

NC = No Connect



Note Refer to Table 7-10, *X Series USB Screw Terminal Device Default NI-DAQmx Counter/Timer Pins*, for a list of the default NI-DAQmx counter/timer pins for this device. For more information about default NI-DAQmx counter inputs, refer to *Connecting Counter Signals* in the *NI-DAQmx Help* or the *LabVIEW Help*.

Figure A-25 shows the pinout of the NI USB-6356/6366 BNC. For a detailed description of each signal, refer to the *I/O Connector Signal Descriptions* section of Chapter 3, *Connector and LED Information*.

Figure A-25. NI USB-6356/6366 BNC Pinout

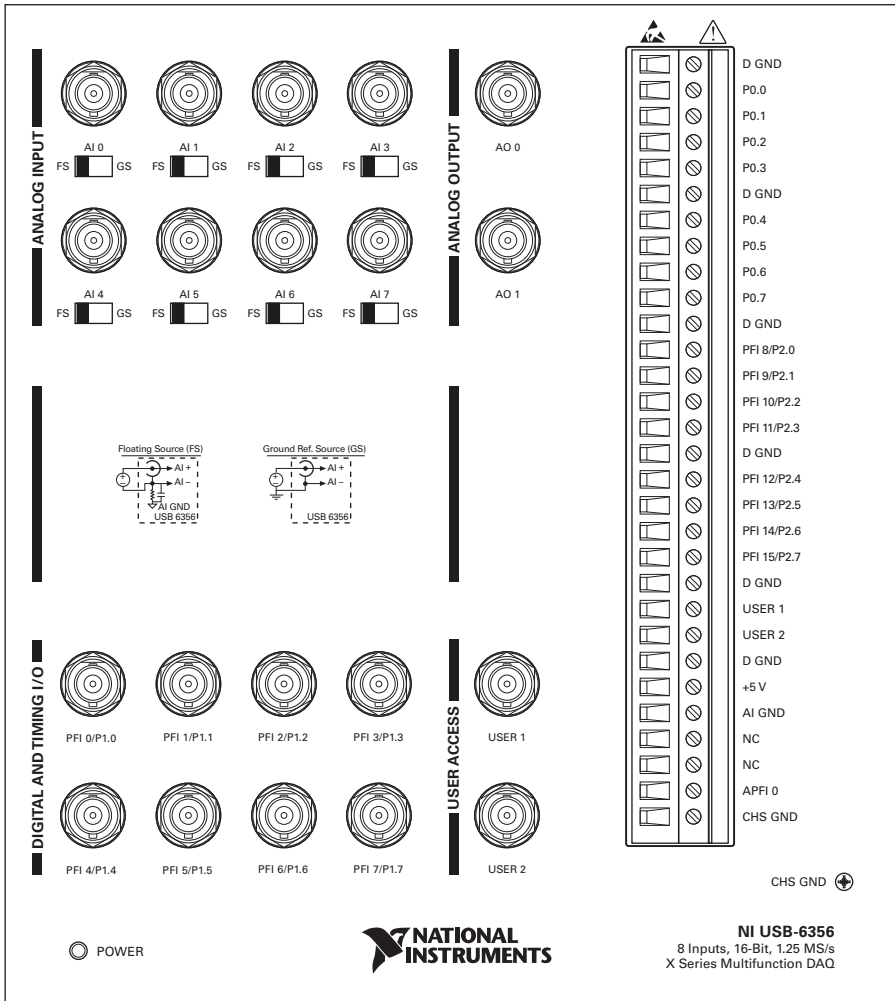

Refer to Table 7-9, *X Series PCI Express/PXI Express/USB Mass Termination/USB BNC Device Default NI-DAQmx Counter/Timer Pins*, for a list of the default NI-DAQmx counter/timer pins for this device. For more information about default NI-DAQmx counter inputs, refer to *Connecting Counter Signals* in the *NI-DAQmx Help* or the *LabVIEW Help*.

NI 6356/6366/6376/6386/6396 Device Specifications

Refer to the following documents for more detailed information on your device:

- **PXIe/USB-6356**—*NI 6356 Device Specifications*
- **PXIe/USB- 6366**—*NI 6366 Device Specifications*
- **PCIe-6376**—*PCIe-6376 Specifications*
- **PXIe-6376**—*NI 6376 Device Specifications*
- **PXIe-6386**—*PXIe-6386 Specifications*
- **PXIe-6396**—*PCIe-6396 Specifications*

NI 6356/6366/6376/6386/6396 Accessory and Cabling Options

NI offers a variety of accessories and cables to use with your DAQ device. Refer to the [Cables and Accessories](#) section of Chapter 2, [DAQ System Overview](#), for more information.

NI 6358/6368/6378

The following sections contain information about the NI PXIe-6358, NI PXIe-6368, and NI PXIe-6378 devices.

NI 6358/6368/6378 Pinout

Figure A-26 shows the pinout of the NI PXIe-6358/6368/6378. The I/O signals appear on two 68-pin connectors. For a detailed description of each signal, refer to the *I/O Connector Signal Descriptions* section of Chapter 3, *Connector and LED Information*.

Figure A-26. NI PXIe-6358/6368/6378 Pinout

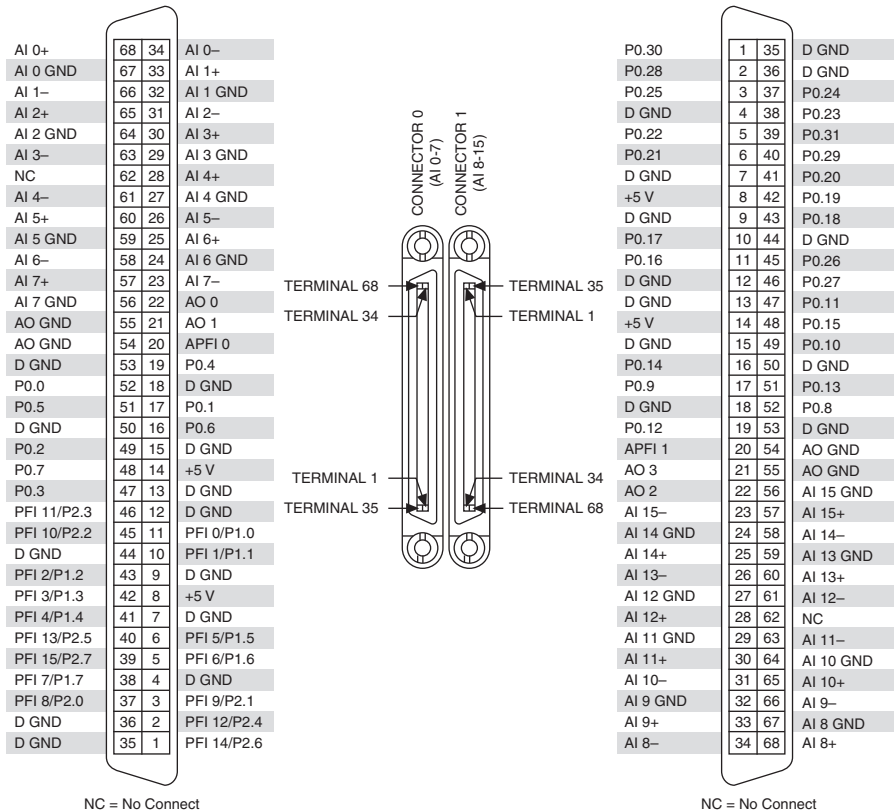

Note Refer to Table 7-9, *X Series PCI Express/PXI Express/USB Mass Termination/USB BNC Device Default NI-DAQmx Counter/Timer Pins*, for a list of the default NI-DAQmx counter/timer pins for this device. For more information about default NI-DAQmx counter inputs, refer to *Connecting Counter Signals* in the *NI-DAQmx Help* or the *LabVIEW Help*.

NI 6358/6368/6378 Device Specifications

Refer to the *NI 6358 Device Specifications* for more detailed information about the NI 6358 device. Refer to the *NI 6368 Device Specifications* for more detailed information about the NI 6368 device. Refer to the *NI 6378 Device Specifications* for more detailed information about the NI 6378 device.

NI 6358/6368/6378 Accessory and Cabling Options

NI offers a variety of accessories and cables to use with your DAQ device. Refer to the [Cables and Accessories](#) section of Chapter 2, *DAQ System Overview*, for more information.

NI 6365

The following sections contain information about the NI PXIe-6365 device.

NI 6365 Pinout

Figure A-27 and Figure A-28 show the pinouts of the NI PXIe-6365. The I/O signals appear on three 68-pin connectors. For a detailed description of each signal, refer to the *I/O Connector Signal Descriptions* section of Chapter 3, *Connector and LED Information*.

Figure A-27. NI PXIe-6365 Connector 2 Pinout

AI 80 (AI 80+)	68	34	AI 88 (AI 80-)
AI 89 (AI 81-)	67	33	AI 81 (AI 81+)
AI 90 (AI 82-)	66	32	AI 82 (AI 82+)
AI 83 (AI 83+)	65	31	AI 91 (AI 83-)
AI 92 (AI 84-)	64	30	AI 84 (AI 84+)
AI 93 (AI 85-)	63	29	AI 85 (AI 85+)
AI 86 (AI 86+)	62	28	AI 94 (AI 86-)
AI 95 (AI 87-)	61	27	AI 87 (AI 87+)
AI 104 (AI 96-)	60	26	AI 96 (AI 96+)
AI 97 (AI 97+)	59	25	AI 105 (AI 97-)
AI 106 (AI 98-)	58	24	AI 98 (AI 98+)
AI 107 (AI 99-)	57	23	AI 99 (AI 99+)
AI SENSE 3	56	22	AI GND
AI 100 (AI 100+)	55	21	AI 108 (AI 100-)
AI 109 (AI 101-)	54	20	AI 101 (AI 101+)
AI 110 (AI 102-)	53	19	AI 102 (AI 102+)
AI 103 (AI 103+)	52	18	AI 111 (AI 103-)
AI 120 (AI 112-)	51	17	AI 112 (AI 112+)
AI 121 (AI 113-)	50	16	AI 113 (AI 113+)
AI 114 (AI 114+)	49	15	AI 122 (AI 114-)
AI 123 (AI 115-)	48	14	AI 115 (AI 115+)
AI 124 (AI 116-)	47	13	AI 116 (AI 116+)
AI 117 (AI 117+)	46	12	AI 125 (AI 117-)
AI 126 (AI 118-)	45	11	AI 118 (AI 118+)
AI 127 (AI 119-)	44	10	AI 119 (AI 119+)
AI GND	43	9	AI GND
AI 128 (AI 128+)	42	8	AI 136 (AI 128-)
AI 137 (AI 129-)	41	7	AI 129 (AI 129+)
AI 138 (AI 130-)	40	6	AI 130 (AI 130+)
AI 131 (AI 131+)	39	5	AI 139 (AI 131-)
AI 140 (AI 132-)	38	4	AI 132 (AI 132+)
AI 141 (AI 133-)	37	3	AI 133 (AI 133+)
AI 134 (AI 134+)	36	2	AI 142 (AI 134-)
AI 143 (AI 135-)	35	1	AI 135 (AI 135+)



Figure A-28. NI PXIe-6365 Connector 0 and Connector 1 Pinout

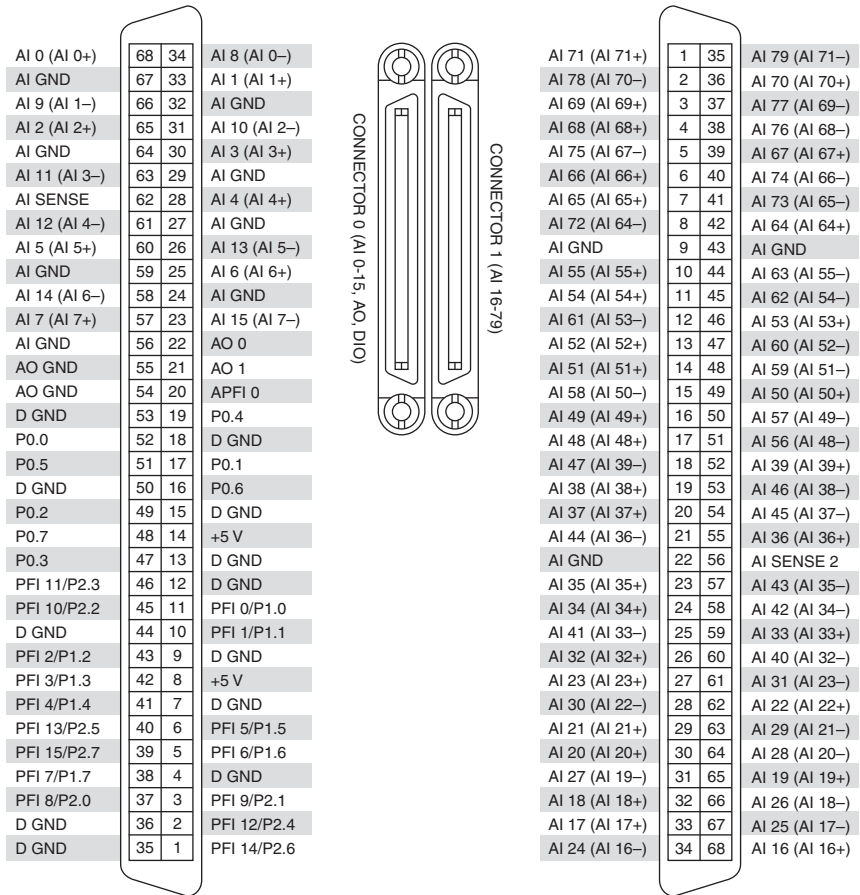

Note Refer to Table 7-9, *X Series PCI Express/PXI Express/USB Mass Termination/USB BNC Device Default NI-DAQmx Counter/Timer Pins*, for a list of the default NI-DAQmx counter/timer pins for this device. For more information about default NI-DAQmx counter inputs, refer to *Connecting Counter Signals* in the *NI-DAQmx Help* or the *LabVIEW Help*.

NI 6365 Device Specifications

Refer to the *NI 6365 Device Specifications* for more detailed information about the NI 6365 device.

NI 6365 Accessory and Cabling Options

NI offers a variety of accessories and cables to use with your DAQ device. Refer to the [Cables and Accessories](#) section of Chapter 2, *DAQ System Overview*, for more information.

NI 6374

The following sections contain information about the NI PCIe-6374 device.

NI 6374 Pinouts

Figure A-29 shows the pinout of the NI PCIe-6374. For a detailed description of each signal, refer to the *I/O Connector Signal Descriptions* section of Chapter 3, *Connector and LED Information*.

Figure A-29. NI PCIe-6374 Pinout

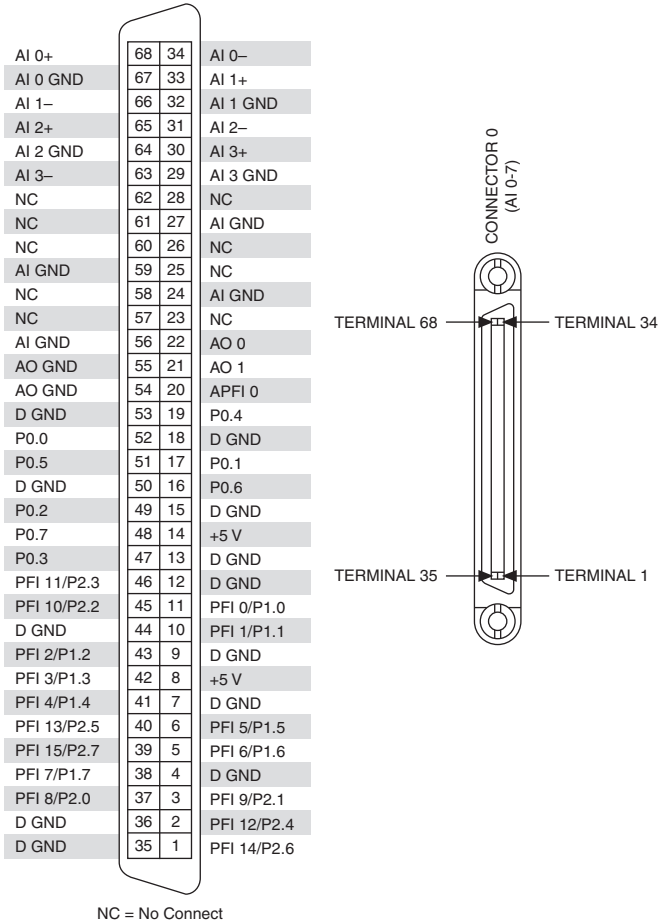



Note Refer to Table 7-9, *X Series PCI Express/PXI Express/USB Mass Termination/USB BNC Device Default NI-DAQmx Counter/Timer Pins*, for a list of the default NI-DAQmx counter/timer pins for this device. For more information about default NI-DAQmx counter inputs, refer to *Connecting Counter Signals* in the *NI-DAQmx Help* or the *LabVIEW Help*.

NI 6374 Specifications

Refer to the *PCIe-6374 Specifications* for more detailed information about the NI 6374 device.

NI 6374 Accessory and Cabling Options

NI offers a variety of accessories and cables to use with your DAQ device. Refer to the *Cables and Accessories* section of Chapter 2, *DAQ System Overview*, for more information.

NI 6375

The following sections contain information about the NI PXIe-6375 device.

NI 6375 Pinout

Figures A-30 and Figure A-31 show the pinouts of the NI PXIe-6375. The I/O signals appear on four 68-pin connectors. For a detailed description of each signal, refer to the *I/O Connector Signal Descriptions* section of Chapter 3, *Connector and LED Information*.

Figure A-30. NI PXIe-6375 Connector 2 and Connector 3 Pinout

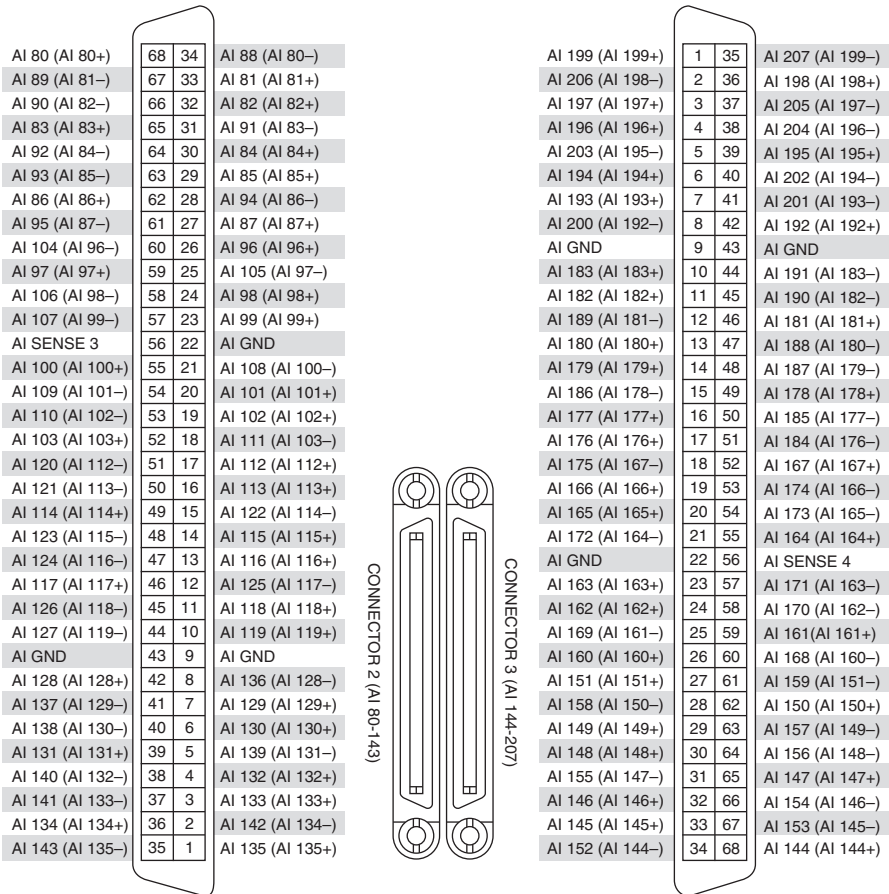
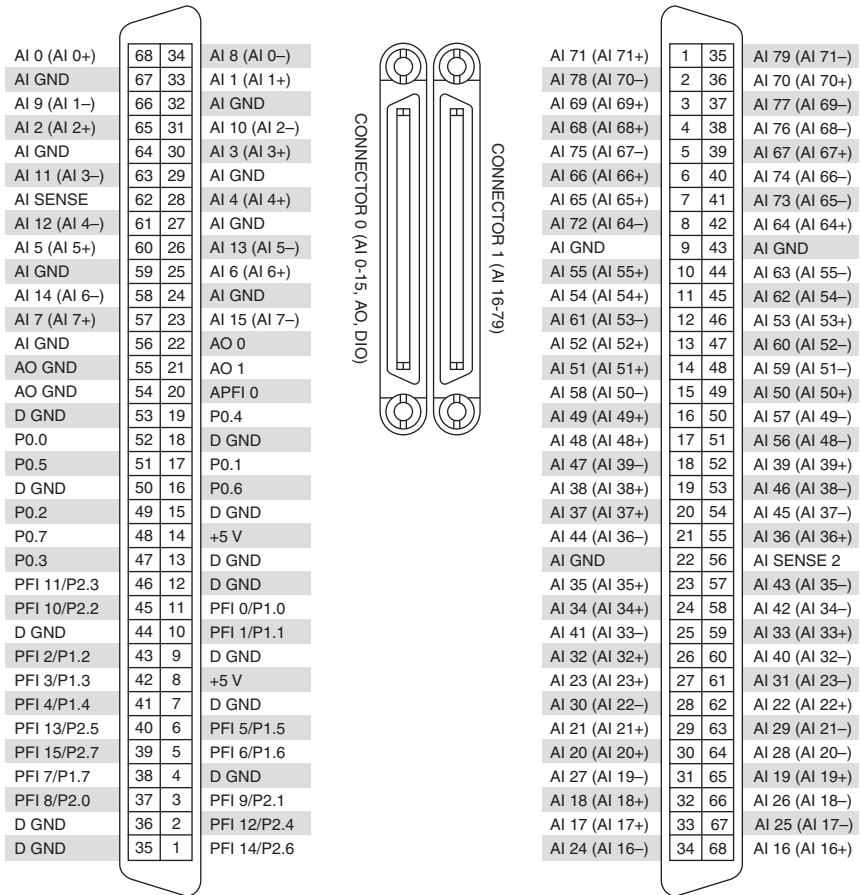

Figure A-31. NI PXIe-6375 Connector 0 and Connector 1 Pinout



Note Refer to Table 7-9, *X Series PCI Express/PXI Express/USB Mass Termination/USB BNC Device Default NI-DAQmx Counter/Timer Pins*, for a list of the default NI-DAQmx counter/timer pins for this device. For more information about default NI-DAQmx counter inputs, refer to *Connecting Counter Signals* in the *NI-DAQmx Help* or the *LabVIEW Help*.

NI 6375 Device Specifications

Refer to the *NI 6375 Device Specifications* for more detailed information about the NI 6375 device.

NI 6375 Accessory and Cabling Options

NI offers a variety of accessories and cables to use with your DAQ device. Refer to the [Cables and Accessories](#) section of Chapter 2, *DAQ System Overview*, for more information.

Where to Go from Here

This section lists where you can find example programs for the X Series device and relevant documentation.

Example Programs

NI-DAQmx software includes example programs to help you get started programming with the X Series device. Modify example code and save it in an application, or use examples to develop a new application, or add example code to an existing application.

To locate NI software examples, go to ni.com/info and enter the Info Code `daqmxexp`. For additional examples, refer to ni.com/examples.

To run examples without the device installed, use an NI-DAQmx simulated device. For more information, in Measurement & Automation Explorer (MAX), select **Help»Help Topics»NI-DAQmx»MAX Help for NI-DAQmx** and search for simulated devices.

Related Documentation

Each application software package and driver includes information about writing applications for taking measurements and controlling measurement devices. The following references to documents assume you have NI-DAQmx 18.0 or later.

X Series Documentation

The X Services device specifications are available for download at ni.com/manuals.

NI-DAQmx

The *NI-DAQmx Readme* lists which devices, ADEs, and NI application software are supported by this version of NI-DAQmx. Select **Start»All Programs»National Instruments»NI-DAQmx»NI-DAQmx Readme**.

The *NI-DAQmx Help* contains API overviews, general information about measurement concepts, key NI-DAQmx concepts, and common applications that are applicable to all programming environments. Select **Start»All Programs»National Instruments»NI-DAQmx»NI-DAQmx Help**.

LabVIEW

Refer to ni.com/gettingstarted for more information about getting started with LabVIEW.

Use the *LabVIEW Help*, available by selecting **Help»LabVIEW Help** in LabVIEW, to access information about LabVIEW programming concepts, step-by-step instructions for using LabVIEW, and reference information about LabVIEW VIs, functions, palettes, menus, and tools. Refer to the following locations on the **Contents** tab of the *LabVIEW Help* for information about NI-DAQmx:

- **VI and Function Reference»Measurement I/O VIs and Functions»DAQmx - Data Acquisition VIs and Functions**—Describes the LabVIEW NI-DAQmx VIs and functions.
- **Property and Method Reference»NI-DAQmx Properties**—Contains the property reference.
- **Taking Measurements**—Contains the conceptual and how-to information you need to acquire and analyze measurement data in LabVIEW, including common measurements, measurement fundamentals, NI-DAQmx key concepts, and device considerations.

LabVIEW NXG

Refer to the *Taking NI-DAQmx Measurements* lessons to assist in getting started in LabVIEW NXG, beginning with *NI-DAQmx API Basics*. To access these lessons, enter `taking NI-DAQmx measurements` in the Search bar in LabVIEW NXG.

LabWindows/CVI

The **Data Acquisition** book of the *LabWindows/CVI Help* contains *Taking an NI-DAQmx Measurement in LabWindows/CVI*, which includes step-by-step instructions about creating a measurement task using the DAQ Assistant. In LabWindows™/CVI™, select **Help»Contents**, then select **Using LabWindows/CVI»Data Acquisition**. This book also contains information about accessing detailed information through the *NI-DAQmx Help*.

The **NI-DAQmx Library** book of the *LabWindows/CVI Help* contains API overviews and function reference for NI-DAQmx. Select **Library Reference»NI-DAQmx Library** in the *LabWindows/CVI Help*.

Microsoft Visual Studio Support

You can use the NI-DAQmx .Net class library to communicate with and control an NI data acquisition (DAQ) device. Documentation for the NI-DAQmx .NET class library is available by selecting **Start»All Programs»National Instruments»NI-DAQmx»NI-DAQmx Documentation** and then opening the NINETDAQmxFxXX.chm help file corresponding to the version of the NI-DAQmx .NET Framework language support you have installed.

- **Measurement Studio Support for NI-DAQmx**-If you program your NI-DAQmx supported device in Visual Studio using Visual C# or Visual Basic .NET, you can interactively create channels and tasks using Measurement Studio and the DAQ Assistant. Additionally, you can use Measurement Studio to generate the configuration code based on your task or channel. Refer to the *DAQ Assistant Help* for additional information about generating code.

To create an NI-DAQmx application using Visual Basic .NET or Visual C#, follow these general steps:

1. In Visual Studio, select **File»New»Project** to launch the New Project dialog box.
2. Choose a programming language (Visual C# or Visual Basic .NET), and then select **Measurement Studio** to see a list of project templates.
3. Select **NI DAQ Windows Application**. You add DAQ tasks as part of this step. Choose a project type. You add DAQ tasks as a part of this step.
4. **.NET Languages without NI Application Software**-With the Microsoft .NET Framework, you can use the NI-DAQmx .NET class library to create applications using Visual C# and Visual Basic .NET without Measurement Studio. Refer to the *NI-DAQmx Readme* for specific versions supported.

ANSI C without NI Application Software

The *NI-DAQmx Help* contains API overviews and general information about measurement concepts. Select **Start»All Programs»National Instruments»NI-DAQmx»NI-DAQmx Help**.

The *NI-DAQmx C Reference Help* describes the NI-DAQmx Library functions, which you can use with National Instruments data acquisition devices to develop instrumentation, acquisition, and control applications. Select **Start»All Programs»National Instruments»NI-DAQmx»Text-Based Code Support»NI-DAQmx C Reference Help**.

Training Courses

If you need more help getting started developing an application with NI products, NI offers training courses. To enroll in a course or obtain a detailed course outline, refer to ni.com/training.

Technical Support on the Web

For additional support, refer to ni.com/support.

Many DAQ device specifications and user guides/manuals are available as PDFs. You must have Adobe Reader 7.0 or later (PDF 1.6 or later) installed to view the PDFs. Refer to the Adobe Systems Incorporated website at www.adobe.com to download Adobe Reader. Refer to the National Instruments Product Manuals Library at ni.com/manuals for updated documentation resources.

Troubleshooting

This section contains common questions about X Series devices. If your questions are not answered here, refer to ni.com/support.

Analog Input

I am seeing crosstalk, or ghost voltages, when sampling multiple channels. What does this mean?

You may be experiencing a phenomenon called charge injection, which occurs when you sample a series of high-output impedance sources with a multiplexer. Multiplexers contain switches, usually made of switched capacitors. When a channel, for example AI 0, is selected in a multiplexer, those capacitors accumulate charge. When the next channel, for example AI 1, is selected, the accumulated current (or charge) leaks backward through channel 1. If the output impedance of the source connected to AI 1 is high enough, the resulting reading can somewhat affect the voltage in AI 0. To circumvent this problem, use a voltage follower that has operational amplifiers (op-amps) with unity gain for each high-impedance source before connecting to an X Series device. Otherwise, you must decrease the sample rate for each channel.

Another common cause of channel crosstalk is due to sampling among multiple channels at various gains. In this situation, the settling times can increase. For more information about charge injection and sampling channels at different gains, refer to the [Multichannel Scanning Considerations](#) section of Chapter 4, [Analog Input](#).

I am using my device in differential analog input ground-reference mode and I have connected a differential input signal, but my readings are random and drift rapidly. What is wrong?

In DIFF mode, if the readings from the DAQ device are random and drift rapidly, you should check the ground-reference connections. The signal can be referenced to a level that is considered floating with reference to the device ground reference. Even if you are in DIFF mode, you must still reference the signal to the same ground level as the device reference. There are various methods of achieving this reference while maintaining a high common-mode rejection ratio (CMRR). These methods are outlined in the [Connecting Analog Input Signals](#) section of Chapter 4, [Analog Input](#).

AI GND is an AI common signal that routes directly to the ground connection point on the devices. You can use this signal if you need a general analog ground connection point to the device. Refer to the [When to Use Differential Connections with Ground-Referenced Signal Sources](#) section of Chapter 4, [Analog Input](#), for more information.

How can I use the AI Sample Clock and AI Convert Clock signals on an MIO X Series device to sample the AI channel(s)?

MIO X Series devices use AI Sample Clock (ai/SampleClock) and AI Convert Clock (ai/ConvertClock) to perform interval sampling. As Figure C-1 shows, AI Sample Clock controls the sample period, which is determined by the following equation:

$$1/\text{sample period} = \text{sample rate}$$

Figure C-1. AI Sample Clock and AI Convert Clock

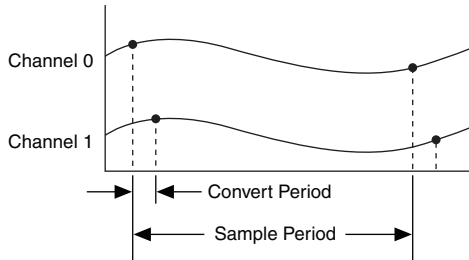

AI Convert Clock controls the convert period, which is determined by the following equation:

$$1/\text{convert period} = \text{convert rate}$$

This method allows multiple channels to be sampled relatively quickly in relationship to the overall sample rate, providing a nearly simultaneous effect with a fixed delay between channels.

Analog Output

I am seeing glitches on the output signal. How can I minimize it?

When you use a DAC to generate a waveform, you may observe glitches on the output signal. These glitches are normal; when a DAC switches from one voltage to another, it produces glitches due to released charges. The largest glitches occur when the most significant bit of the DAC code changes. You can build a lowpass deglitching filter to remove some of these glitches, depending on the frequency and nature of the output signal. Visit ni.com/support for more information about reducing glitches.

Counters

How do I connect counter signals to my X Series device?

The [Default Counter/Timer Pins](#) section of Chapter 7, [Counters](#), has information about counter signal connections.

NI Services

National Instruments provides global services and support as part of our commitment to your success. Take advantage of product services in addition to training and certification programs that meet your needs during each phase of the application life cycle; from planning and development through deployment and ongoing maintenance.

To get started, register your product at ni.com/myproducts.

As a registered NI product user, you are entitled to the following benefits:

- Access to applicable product services.
- Easier product management with an online account.
- Receive critical part notifications, software updates, and service expirations.

Log in to your National Instruments ni.com User Profile to get personalized access to your services.

Services and Resources

- **Maintenance and Hardware Services**—NI helps you identify your systems' accuracy and reliability requirements and provides warranty, sparing, and calibration services to help you maintain accuracy and minimize downtime over the life of your system. Visit ni.com/services for more information.
 - **Warranty and Repair**—All NI hardware features a one-year standard warranty that is extendable up to five years. NI offers repair services performed in a timely manner by highly trained factory technicians using only original parts at a National Instruments service center.
 - **Calibration**—Through regular calibration, you can quantify and improve the measurement performance of an instrument. NI provides state-of-the-art calibration services. If your product supports calibration, you can obtain the calibration certificate for your product at ni.com/calibration.
- **System Integration**—If you have time constraints, limited in-house technical resources, or other project challenges, National Instruments Alliance Partner members can help. To learn more, call your local NI office or visit ni.com/alliance.

- **Training and Certification**—The NI training and certification program is the most effective way to increase application development proficiency and productivity. Visit ni.com/training for more information.
 - The Skills Guide assists you in identifying the proficiency requirements of your current application and gives you options for obtaining those skills consistent with your time and budget constraints and personal learning preferences. Visit ni.com/skills-guide to see these custom paths.
 - NI offers courses in several languages and formats including instructor-led classes at facilities worldwide, courses on-site at your facility, and online courses to serve your individual needs.
- **Technical Support**—Support at ni.com/support includes the following resources:
 - **Self-Help Technical Resources**—Visit ni.com/support for software drivers and updates, a searchable KnowledgeBase, product manuals, step-by-step troubleshooting wizards, thousands of example programs, tutorials, application notes, instrument drivers, and so on. Registered users also receive access to the NI Discussion Forums at ni.com/forums. NI Applications Engineers make sure every question submitted online receives an answer.
 - **Software Support Service Membership**—The Standard Service Program (SSP) is a renewable one-year subscription included with almost every NI software product, including NI Developer Suite. This program entitles members to direct access to NI Applications Engineers through phone and email for one-to-one technical support, as well as exclusive access to online training modules at ni.com/self-paced-training. NI also offers flexible extended contract options that guarantee your SSP benefits are available without interruption for as long as you need them. Visit ni.com/ssp for more information.
- **Declaration of Conformity (DoC)**—A DoC is our claim of compliance with the Council of the European Communities using the manufacturer’s declaration of conformity. This system affords the user protection for electromagnetic compatibility (EMC) and product safety. You can obtain the DoC for your product by visiting ni.com/certification.

For information about other technical support options in your area, visit ni.com/services, or contact your local office at ni.com/contact.

You can also visit the Worldwide Offices section of ni.com/niglobal to access the branch office websites, which provide up-to-date contact information, support phone numbers, email addresses, and current events.

Index

Symbols

+5 V power source, 3-5

Numerics

10 MHz reference clock, 9-3

100 kHz Timebase, 9-2

100 MHz

source mode, 8-47

Timebase, 9-2

20 MHz Timebase, 9-2

A

A/D converter, MIO X Series devices, 4-2

AC coupling connections

Simultaneous MIO X Series devices,
4-43

accessories, 2-3

choosing for your device, 1-10

field wiring considerations

Simultaneous MIO X Series
devices, 4-44

NI 6320, A-3

NI 6321/6341, A-7

NI 6323/6343, A-11

NI 6345/6355, A-13, A-17, A-20

NI 6351/6361, A-26

NI 6353/6363, A-32

NI 6356/6366/6376, A-38

NI 6358/6368/6378, A-40

NI 6365, A-43

NI 6374, A-45

NI 6375, A-48

accuracy, analog triggers, 11-6

acquisitions

circular-buffered

MIO X Series devices, 4-9

Simultaneous MIO X Series
devices, 4-39

digital waveform, 6-4

double-buffered

MIO X Series devices, 4-9

Simultaneous MIO X Series
devices, 4-39

hardware-timed

MIO X Series devices, 4-9

Simultaneous MIO X Series
devices, 4-38

on-demand

MIO X Series devices, 4-9

Simultaneous MIO X Series
devices, 4-38

software-timed

MIO X Series devices, 4-9

Simultaneous MIO X Series
devices, 4-38

AI Convert Clock signal, 4-27

AI Convert Clock Timebase signal, 4-30

AI FIFO

MIO X Series devices, 4-2

Simultaneous MIO X Series devices,
4-36

AI Hold Complete Event signal

MIO X Series devices, 4-30

Simultaneous MIO X Series devices,
4-50

AI Pause Trigger signal

MIO X Series devices, 4-34

Simultaneous MIO X Series devices,
4-55

AI Reference Trigger signal

MIO X Series devices, 4-32

Simultaneous MIO X Series devices,
4-53

AI Sample Clock signal

MIO X Series devices, 4-24

Simultaneous MIO X Series devices,
4-48

AI Sample Clock Timebase signal

MIO X Series devices, 4-26

Simultaneous MIO X Series devices,
4-49

AI Start Trigger signal

MIO X Series devices, 4-30

- Simultaneous MIO X Series devices, 4-50
- ai/ConvertClock, 4-27
- ai/ConvertClockTimebase, 4-30
- ai/HoldCompleteEvent
 - MIO X Series devices, 4-30
 - Simultaneous MIO X Series devices, 4-50
- ai/PauseTrigger
 - MIO X Series devices, 4-34
 - Simultaneous MIO X Series devices, 4-55
- ai/ReferenceTrigger
 - MIO X Series devices, 4-32
 - Simultaneous MIO X Series devices, 4-53
- ai/SampleClock
 - MIO X Series devices, 4-24
 - Simultaneous MIO X Series devices, 4-48
- ai/SampleClockTimebase
 - MIO X Series devices, 4-26
 - Simultaneous MIO X Series devices, 4-49
- ai/StartTrigger
 - MIO X Series devices, 4-30
 - Simultaneous MIO X Series devices, 4-50
- analog
 - comparison event, routing, 11-4
 - comparison event, signal, 11-3
 - edge triggering, 11-4
 - with hysteresis, 11-4
 - trigger actions, 11-3
 - trigger types, 11-4
 - triggering, 11-2
- analog input
 - channels, 11-3
 - charge injection, C-1
 - crosstalk when sampling multiple channels, C-1
 - differential, troubleshooting, C-1
 - ghost voltages when sampling multiple channels, C-1
 - MIO X Series devices, 4-1
 - AI Convert Clock, 4-27
 - AI Convert Clock Timebase, 4-30
 - AI Hold Complete Event, 4-30
 - AI Pause Trigger, 4-34
 - AI Reference Trigger, 4-32
 - AI Sample Clock, 4-24
 - AI Sample Clock Timebase, 4-26
 - AI Start Trigger, 4-30
 - channels, sampling with AI Sample Clock and AI Convert Clock, C-2
 - circuitry, 4-1
 - connecting, 4-10
 - connecting signals, 4-10
 - connecting through I/O connector, 4-1
 - data acquisition methods, 4-9
 - getting started with applications in software, 4-35
 - ground-reference settings, 4-1
 - MUX, 4-1
 - range, 4-2
 - sampling channels with AI Sample Clock and AI Convert Clock, C-2
 - signals, 4-22
 - timing signals, 4-22
 - triggering, 4-10
- Simultaneous MIO X Series devices
 - AI Hold Complete Event, 4-50
 - AI Pause Trigger, 4-55
 - AI Reference Trigger, 4-53
 - AI Sample Clock, 4-48
 - AI Sample Clock Timebase, 4-49
 - circuitry, 4-36
 - connecting signals, 4-41
 - connecting through I/O connector, 4-36
 - data acquisitions, 4-38
 - methods, 4-38
 - fundamentals, 4-36
 - overview, 4-36
 - signals, 4-45
 - terminal configuration, 4-37
 - timing signals, 4-45

- timing summary, 4-46
 - triggering, 4-40
- troubleshooting, C-1
- analog output
 - circuitry, 5-1
 - connecting signals, 5-5
 - data generation methods, 5-3
 - fundamentals, 5-1
 - getting started with applications in software, 5-11
 - glitches on the output signal, 5-2
 - reference selection, 5-2
 - signals, 5-5
 - AO Pause Trigger, 5-7
 - AO Sample Clock, 5-8
 - AO Sample Clock Timebase, 5-10
 - AO Start Trigger, 5-6
 - timing signals, 5-5
 - trigger signals, 5-4
 - triggering, 5-4
 - troubleshooting, C-2
- analog source, triggering, 11-2
- analog trigger, 11-2
 - accuracy, 11-6
 - actions, 11-3
 - improving accuracy, 11-6
- analog window triggering, 11-6
- analog-to-digital converter
 - MIO X Series devices, 4-2
 - Simultaneous MIO X Series devices, 4-36
- ANSI C documentation, B-3
- AO FIFO, 5-1
- AO Pause Trigger signal, 5-7
- AO reference selection, 5-1
- AO reference selection settings, 5-2
- AO Sample Clock, 5-1
- AO Sample Clock signal, 5-8
- AO Sample Clock Timebase signal, 5-10
- AO Start Trigger signal, 5-6
- ao/PauseTrigger, 5-7
- ao/SampleClock, 5-8
- ao/StartTrigger, 5-6
- APFI <0, 1> terminals, 11-2
- applications

- counter input, 8-3
 - counter output, 8-26
 - edge counting, 8-3
- applying rubber feet, 1-7
- arm start trigger, 8-45
- avoiding scanning faster than necessary (MIO X Series devices), 4-8

B

- buffered
 - edge counting, 8-4
 - hardware-timed acquisitions
 - MIO X Series devices, 4-9
 - Simultaneous MIO X Series devices, 4-39
 - hardware-timed generations, 5-3, 6-12
 - position measurement, 8-23
 - two-signal edge-separation measurement, 8-25
- bus
 - interface, 10-1
 - RTSI, 9-4

C

- cable management, 1-7
- cables, 2-3
 - choosing for your device, 1-10
 - custom, 2-7
 - NI 6320, A-3
 - NI 6321/6341, A-7
 - NI 6323/6343, A-11
 - NI 6345/6355, A-13, A-17, A-20
 - NI 6351/6361, A-26
 - NI 6353/6363, A-32
 - NI 6356/6366/6376, A-38
 - NI 6358/6368/6378, A-40
 - NI 6365, A-43
 - NI 6374, A-45
 - NI 6375, A-48
 - X Series devices, 2-4
- calibration, 1-4
 - circuitry, 2-3
- cascading counters, 8-45
- cDAQ chassis
 - example programs, B-1

- Change Detection Event signal, 6-19
- channel
 - scanning order (MIO X Series devices), 4-7
 - Z behavior, 8-22
- channels
 - analog input, 11-3
 - sampling with AI Sample Clock and AI Convert Clock, C-2
- charge injection, C-1
- choosing frequency measurement, 8-16
- CHS GND screw terminal, 1-5
- circular-buffered acquisition
 - MIO X Series devices, 4-9
 - Simultaneous MIO X Series devices, 4-39
- clock
 - 10 MHz reference, 9-3
 - external reference, 9-2
 - generation, 9-1
 - PXI, PXI Express, and trigger signals, 9-7
 - routing, 9-1
- common-mode noise
 - differential ground-referenced signals (Simultaneous MIO X Series devices), 4-42
 - differential non-referenced or floating signals (Simultaneous MIO X Series devices), 4-44
 - differential signals (Simultaneous MIO X Series devices), 4-42
 - signal rejection considerations
 - differential ground-referenced signals (Simultaneous MIO X Series devices), 4-42
- configuring AI ground-reference settings in software
 - MIO X Series devices, 4-6
 - Simultaneous MIO X Series devices, 4-56
- connecting
 - analog input signals
 - MIO X Series devices, 4-10
 - analog output signals, 5-5
 - counter signals, C-2
 - digital I/O signals, 6-24
 - floating signal sources
 - MIO X Series devices, 4-12
 - ground-referenced signal sources
 - MIO X Series devices, 4-17
 - PFI input signals, 7-4
 - connecting signals
 - analog input
 - Simultaneous MIO X Series devices, 4-41
- connections
 - differential for floating signal sources
 - MIO X Series devices, 4-17
 - differential for ground-referenced signal sources
 - Simultaneous MIO X Series devices, 4-42
 - for floating signal sources
 - Simultaneous MIO X Series devices, 4-43
 - single-ended for floating signal sources
 - MIO X Series devices, 4-17
 - single-ended, RSE configuration
 - MIO X Series devices, 4-17
- connector
 - information, 3-1
 - NI PCIe/PXIe-6341, A-4
 - NI PCIe/PXIe-6361, A-21
 - NI PCIe/PXIe-6363, A-27
 - NI PCIe-6320, A-2, A-41
 - NI PCIe-6321, A-4
 - NI PCIe-6323/6343, A-8
 - NI PCIe-6351, A-21
 - NI PCIe-6353 Screw Terminal, A-27
 - NI PCIe-6374, A-44
 - NI PCIe-6376, A-33
 - NI PXIe-6345/6355, A-12, A-14, A-18
 - NI PXIe-6356/6366/6376, A-33
 - NI PXIe-6358/6368/6378, A-39
 - NI PXIe-6375, A-46
 - NI USB-6341 BNC, A-6
 - NI USB-6341 Screw Terminal, A-5
 - NI USB-6343, A-9

- NI USB-6343 BNC, A-10
- NI USB-6351/6361 Screw Terminal, A-22
- NI USB-6353 Mass Termination, A-28
- NI USB-6356/6366 Screw Terminal, A-36
- NI USB-6361 Mass Termination, A-23
- NI USB-6363 Screw Terminal, A-31
- RTSI, 3-7
- considerations
 - for field wiring
 - MIO X Series devices, 4-21
 - Simultaneous MIO X Series devices, 4-44
 - for multichannel scanning (MIO X Series devices), 4-6
 - for PXI Express, 10-3
- continuous pulse train generation, 8-30
- controller, DMA, 10-1
- controlling counting direction, 8-3
- counter
 - input and output, 8-42
 - output applications, 8-26
 - terminals, default, 8-42
- Counter *n* A signal, 8-39
- Counter *n* Aux signal, 8-38
- Counter *n* B signal, 8-39
- Counter *n* Gate signal, 8-37
- Counter *n* HW Arm signal, 8-39
- Counter *n* Internal Output signal, 8-41
- Counter *n* Sample Clock signal, 8-40
- Counter *n* Source signal, 8-36
- Counter *n* TC signal, 8-41
- Counter *n* Up_Down signal, 8-39
- Counter *n* Z signal, 8-39
- counter signals
 - Counter *n* A, 8-39
 - Counter *n* Aux, 8-38
 - Counter *n* B, 8-39
 - Counter *n* Gate, 8-37
 - Counter *n* HW Arm, 8-39
 - Counter *n* Internal Output, 8-41
 - Counter *n* Source, 8-36
 - Counter *n* TC, 8-41
 - Counter *n* Up_Down, 8-39

- FREQ OUT, 8-41
- Frequency Output, 8-41
- counters, 8-1
 - cascading, 8-45
 - connecting terminals, 8-42
 - edge counting, 8-3
 - generation, 8-26
 - input applications, 8-3
 - other features, 8-45
 - output applications, 8-26
 - prescaling, 8-46
 - pulse train generation, 8-28
 - retriggerable single pulse generation, 8-29
 - simple pulse generation, 8-27
 - single pulse generation, 8-27
 - single pulse generation with start trigger, 8-27
 - synchronization modes, 8-46
 - timing signals, 8-36
 - triggering, 8-45
 - troubleshooting, C-2
- counting edges, 8-3
- crosstalk when sampling multiple channels, C-1
- CtrnSampleClock, 8-40
- custom cabling, 2-7

D

- DACs, 5-1
- DAQ
 - hardware, 2-2
 - system, 2-1
- DAQ-6202, 2-2
- DAQ-STC3, 2-2
- data
 - acquisition methods
 - Simultaneous MIO X Series devices, 4-38
 - generation methods, 5-3
 - transfer methods
 - DMA, 10-1
 - programmed I/O, 10-2
 - USB Signal Stream, 10-2
- data acquisition methods

- MIO X Series devices, 4-9
- Simultaneous MIO X Series devices, 4-38
- DC coupling, connections (Simultaneous MIO X Series devices), 4-43
- default
 - counter terminals, 8-42
 - NI-DAQmx counter/timer pins, 8-42
 - pins, 8-42
- desktop use, 1-7
- device
 - information, A-1
 - multiple synchronization, 9-3
 - NI 6345/6355, A-14, A-18
 - pinouts, 1-10
 - self-calibration, 1-4
 - specifications, 1-10
- DI change detection, 6-19
- DI Sample Clock signal, 6-4
- di/SampleClock, 6-4
- DIFF connections
 - using with floating signal sources (MIO X Series devices), 4-13
 - using with ground-referenced signal sources (MIO X Series devices), 4-19
 - when to use with floating signal sources (MIO X Series devices), 4-12
 - when to use with ground-referenced signal sources (MIO X Series devices), 4-18
- differential analog input, troubleshooting, C-1
- differential connections
 - for ground-referenced signal sources
 - Simultaneous MIO X Series devices, 4-42
 - for non-referenced or floating signal sources
 - Simultaneous MIO X Series devices, 4-43
 - using with floating signal sources
 - MIO X Series devices, 4-13
 - using with ground-referenced signal sources
 - MIO X Series devices, 4-19
 - when to use with floating signal sources
 - MIO X Series devices, 4-12
 - when to use with ground-referenced signal sources
 - MIO X Series devices, 4-18
- digital
 - waveform acquisition, 6-4
 - waveform generation, 6-13
- digital I/O
 - block diagram, 6-1
 - circuitry, 6-1
 - connecting signals, 6-24
 - DI change detection, 6-19
 - digital waveform generation, 6-13
 - getting started with applications in software, 6-25
 - I/O protection, 6-18
 - programmable power-up states, 6-18
 - static DIO, 6-2
 - triggering, 11-1
 - waveform acquisition, 6-4
- digital output
 - trigger signals, 6-12
 - triggering, 6-12
- digital routing, 9-1
- digital signals
 - Change Detection Event, 6-19
 - connecting, 6-24
 - Counter *n* Sample Clock, 8-40
 - DI Sample Clock, 6-4
 - DO Sample Clock, 6-13
- digital source, triggering, 11-1
- digital waveform
 - acquisition, 6-4
 - generation, 6-13
- disk drive power (PCI Express), 3-6
- disk drive power connector (PCI Express devices), 3-6
- DMA
 - as a transfer method, 10-1
 - controllers, 10-1
- DO Sample Clock signal, 6-13
- do/SampleClock, 6-13
- documentation
 - related documentation, B-1
- double-buffered acquisition

- MIO X Series devices, 4-9
- Simultaneous MIO X Series devices, 4-39

E

- edge counting, 8-3
 - buffered, 8-4
 - on-demand, 8-4
 - sample clock, 8-4
 - single point, 8-4
- edge-separation measurement
 - buffered two-signal, 8-25
 - single two-signal, 8-24
- encoders, quadrature, 8-21
- encoding
 - X1, 8-21
 - X2, 8-21
 - X4, 8-22
- equivalent time sampling, 8-35
- example programs, B-1
- exporting timing output signals using PFI terminals, 7-2
- external reference clock, 9-2
- external source
 - greater than 40 MHz, 8-47
 - less than 40 MHz, 8-47

F

- features, counter, 8-45
- field wiring considerations
 - MIO X Series devices, 4-21
 - Simultaneous MIO X Series devices, 4-44
- FIFO
 - Simultaneous MIO X Series devices, 4-36
- filters
 - PFI, 7-4
 - PXI_STAR, 9-8
 - RTSI, 9-7
- floating signal sources
 - connecting
 - MIO X Series devices, 4-12
 - description
 - MIO X Series devices, 4-12

- using in differential mode
 - MIO X Series devices, 4-13
- using in NRSE mode
 - MIO X Series devices, 4-16
- using in RSE mode
 - MIO X Series devices, 4-17
- when to use in differential mode
 - MIO X Series devices, 4-12
- when to use in NRSE mode
 - MIO X Series devices, 4-12
- when to use in RSE mode
 - MIO X Series devices, 4-13

- FREQ OUT signal, 8-41

- frequency

- division, 8-35
- generation, 8-34
- generator, 8-34
- measurement, 8-11

- Frequency Output signal, 8-41

G

- generations
 - analog output data, 5-3
 - buffered hardware-timed, 5-3, 6-12
 - clock, 9-1
 - continuous pulse train, 8-30
 - digital waveform, 6-13
 - frequency, 8-34
 - hardware-timed, 5-3, 6-11
 - hardware-timed single point, 5-3, 6-3, 6-11
 - pulse for ETS, 8-35
 - pulse train, 8-28
 - retriggerable single pulse, 8-29
 - simple pulse, 8-27
 - single pulse, 8-27
 - single pulse with start trigger, 8-27
 - software-timed, 5-3, 6-11
- getting started, 1-3
 - AI applications in software
 - MIO X Series devices, 4-35
 - AO applications in software, 5-11
 - DIO applications in software, 6-25
- ghost voltages when sampling multiple channels, C-1

- Ground, 4-41
- ground-reference
 - connections, checking, C-1
 - settings
 - analog input
 - MIO X Series devices, 4-4
 - MIO X Series devices, 4-1, 4-4
 - ground-referenced signal sources
 - connecting
 - MIO X Series devices, 4-17
 - description
 - MIO X Series devices, 4-17
 - using in differential mode
 - MIO X Series devices, 4-19
 - using in NRSE mode
 - MIO X Series devices, 4-20
 - when to use in differential mode
 - MIO X Series devices, 4-18
 - when to use in NRSE mode
 - MIO X Series devices, 4-18
 - when to use in RSE mode
 - MIO X Series devices, 4-19
- H**
- hardware, 2-2
- hardware installation, 1-3
- hardware-timed
 - acquisitions
 - MIO X Series devices, 4-9
 - Simultaneous MIO X Series devices, 4-38
 - generations, 5-3, 6-11
- hardware-timed single point
 - acquisitions
 - MIO X Series devices, 4-10
 - hardware-timed generations, 5-3, 6-3, 6-11
- hysteresis, analog edge triggering with, 11-4
- I**
- I/O connector, 3-1
 - NI PCIe/PXIE-6341 pinout, A-4
 - NI PCIe/PXIE-6361 pinout, A-21
 - NI PCIe/PXIE-6363 pinout, A-27
 - NI PCIe-6320 pinout, A-2, A-41
 - NI PCIe-6321 pinout, A-4
 - NI PCIe-6323/6343 pinout, A-8
 - NI PCIe-6351 pinout, A-21
 - NI PCIe-6353 pinout, A-27
 - NI PCIe-6374 pinout, A-44
 - NI PCIe-6376 pinout, A-33
 - NI PXIE-6345/6355 pinout, A-12, A-14, A-18
 - NI PXIE-6356/6366/6376 pinout, A-33
 - NI PXIE-6358/6368/6378 pinout, A-39
 - NI USB-6341 BNC pinout, A-6
 - NI USB-6341 Screw Terminal pinout, A-5
 - NI USB-6343 BNC pinout, A-10
 - NI USB-6343 pinout, A-9
 - NI USB-6343 Screw Terminal pinout, A-9
 - NI USB-6351/6361 Mass Termination pinout, A-23
 - NI USB-6351/6361 pinout, A-28
 - NI USB-6351/6361 Screw Terminal pinout, A-22
 - NI USB-6356/6366 pinout, A-36
 - NI USB-6363 pinout, A-31
- I/O protection, 6-18, 7-6
- implicit buffered
 - pulse-width measurement, 8-6
 - semi-period measurement, 8-11
- improving analog trigger accuracy, 11-6
- input signals
 - using PFI terminals as, 7-2
 - using RTSI terminals as, 9-6
- insertion of grounded channels between
 - signal channels (MIO X Series devices), 4-8
- installation
 - hardware, 1-3
 - NI-DAQ, 1-3
 - other software, 1-3
- instrumentation amplifier
 - MIO X Series devices, 4-2
 - Simultaneous MIO X Series devices, 4-36
- interface, bus, 10-1
- internal source less than 40 MHz, 8-47

L

LabVIEW documentation, B-2
 LabWindows/CVI documentation, B-2
 LED patterns (USB devices), 3-7
 low impedance sources (MIO X Series devices), 4-7

M

measurements

- buffered two-signal edge-separation, 8-25
- choosing frequency, 8-16
- frequency, 8-11
- implicit buffered pulse-width, 8-6
- implicit buffered semi-period, 8-11
- period, 8-20
- position, 8-21
- pulse-width, 8-5
- semi-period, 8-10
- single pulse-width, 8-6
- single semi-period, 8-11
- single two-signal edge-separation, 8-24
- two-signal edge-separation, 8-24
- using quadrature encoders, 8-21
- using two pulse encoders, 8-23

measuring

- high frequency with two counters, 8-12
- large range of frequencies using two counters, 8-13
- low frequency, 8-12

methods, data transfer, 10-1, 10-2

minimizing

- glitches on the output signal, 5-2
- output signal glitches, C-2
- voltage step between adjacent channels (MIO X Series devices), 4-8

multichannel scanning considerations

- MIO X Series devices, 4-6

multiple device synchronization, 9-3

mux

- MIO X Series devices, 4-1

N

NI 6320, A-2

- accessory options, A-3
- cabling options, A-3
- pinout, A-2
- specifications, A-3

NI 6321/6341, A-4

- accessory options, A-7
- cabling options, A-7
- PCI Express pinout, A-4
- PXI Express pinout, A-4
- specifications, A-7
- USB BNC pinout, A-6
- USB pinout, A-5

NI 6323/6343, A-8

- accessory options, A-11
- cabling options, A-11
- PCI Express pinout, A-8
- USB pinout, A-9

NI 6343

- USB BNC pinout, A-10
- USB pinout, A-10

NI 6345/6355, A-12, A-14, A-18

- accessory options, A-13, A-17, A-20
- cabling options, A-13, A-17, A-20
- pinout, A-12, A-14, A-18
- specifications, A-13, A-17, A-20

NI 6351/6361

- accessory options, A-26
- cabling options, A-26
- PCI Express pinout, A-21
- PXI Express pinout, A-21
- specifications, A-26
- USB pinout, A-22, A-23, A-28

NI 6353/6363, A-27

- accessory options, A-32
- cabling options, A-32
- PCI Express pinout, A-27
- PXI Express pinout, A-27
- specifications, A-32

NI 6356/6366

- USB pinout, A-36

NI 6356/6366/6376

- accessory options, A-38
- cabling options, A-38
- PCI Express pinout, A-33
- PXI Express pinout, A-33

- specifications, A-38
 - NI 6358/6368/6378
 - accessory options, A-40
 - cabling options, A-40
 - pinout, A-39
 - specifications, A-40
 - NI 6363
 - USB BNC pinout, A-31
 - NI 6365, A-41
 - accessory options, A-43
 - cabling options, A-43
 - pinout, A-41
 - specifications, A-43
 - NI 6374
 - accessory options, A-45
 - cabling options, A-45
 - pinout, A-44
 - specifications, A-45
 - NI 6375, A-46
 - accessory options, A-48
 - cabling options, A-48
 - pinout, A-46
 - specifications, A-48
 - NI USB 6361
 - BNC pinout, A-24
 - NI USB-6356/6366 BNC
 - pinout, A-37
 - NI-DAQmx
 - default counter terminals, 8-42
 - documentation, B-1
 - installation, 1-3
 - NI-PGIA
 - MIO X Series devices, 4-2
 - Simultaneous MIO X Series devices, 4-36
 - non-buffered
 - hardware-timed acquisitions
 - Simultaneous MIO X Series devices, 4-40
 - non-referenced single-ended connections
 - using with floating signal sources
 - MIO X Series devices, 4-16
 - using with ground-referenced signal sources
 - MIO X Series devices, 4-20
 - when to use with floating signal sources
 - MIO X Series devices, 4-12
 - when to use with ground-referenced signal sources
 - MIO X Series devices, 4-18
 - NRSE connections
 - using with floating signal sources, 4-16
 - using with ground-referenced signal sources, 4-20
 - when to use with floating signal sources, 4-12
 - when to use with ground-referenced signal sources, 4-18
- ## O
- on-demand
 - acquisitions
 - MIO X Series devices, 4-9
 - Simultaneous MIO X Series devices, 4-38
 - edge counting, 8-4
 - timing
 - MIO X Series devices, 4-9
 - Simultaneous MIO X Series devices, 4-38
 - order of channels for scanning (MIO X Series devices), 4-7
 - other, software, installing, 1-3
 - output
 - signal glitches, C-2
 - minimizing, 5-2
 - terminal, routing analog comparison events, 11-4
 - outputs, using RTSI as, 9-6
 - overview, 2-1
- ## P
- pause trigger, 8-45
 - PCI Express disk drive power connector, 3-6
 - period measurement, 8-20
 - PFI, 7-1
 - connecting input signals, 7-4
 - exporting timing output signals using PFI terminals, 7-2
 - filters, 7-4

- I/O protection, 7-6
- programmable power-up states, 7-6
- using terminals as static digital I/Os, 7-3
- using terminals as timing input signals, 7-2
- PFI terminals as static digital I/Os, 7-3
- pin assignments. *See* pinouts
- pinouts
 - counter default, 8-42
 - device, 1-10
 - NI PCIe/PXIe-6341, A-4
 - NI PCIe/PXIe-6361, A-21
 - NI PCIe/PXIe-6363, A-27
 - NI PCIe-6320, A-2
 - NI PCIe-6321, A-4
 - NI PCIe-6323/6343, A-8
 - NI PCIe-6351/6361, A-21, A-22, A-23, A-28
 - NI PCIe-6353/6363, A-27
 - NI PCIe-6374, A-44
 - NI PCIe-6376, A-33
 - NI PXIe-6345/6355, A-12, A-14, A-18
 - NI PXIe-6356/6366/6376, A-33
 - NI PXIe-6358/6368/6378, A-39
 - NI PXIe-6365, A-41
 - NI PXIe-6375, A-46
 - NI USB-6343, A-9
 - NI USB-6351/6361, A-22, A-23, A-28
 - NI USB-6356/6366, A-36
 - NI USB-6363 USB, A-31
 - RTSI connector, 3-7, 9-5
- pins, default, 8-42
- position measurement, 8-21
 - buffered, 8-23
- power
 - +5 V, 3-5
 - connector, PCI Express disk drive, 3-6
- power-up states, 6-18, 7-6
- prescaling, 8-46
- programmable
 - function interface (PFI), 7-1
 - power-up states, 6-18, 7-6
- programmed I/O, 10-2
- programming devices in software, 2-10
- pulse

- encoders, 8-23
- generation for ETS, 8-35
- train generation, 8-28
 - continuous, 8-30
- pulse-width measurement
 - implicit buffered, 8-6
 - single, 8-6
- PXI
 - and PXI Express, 10-3
 - clock, 10-3
 - clock and trigger signals, 9-7
 - trigger signals, 10-3
 - triggers, 9-8
- PXI Express
 - and PXI, 10-3
 - chassis compatibility, 10-3
 - clock, 10-3
 - clock and trigger signals, 9-7
 - considerations, 10-3
 - PXIe_CLK100, 9-7
 - PXIe_SYNC100, 9-7
 - PXIe-DSTAR<A..C>, 9-9
- PXI_CLK10, 9-8
- PXI_STAR
 - filters, 9-8
 - trigger, 9-8
- PXIe_CLK100, 9-7
- PXIe_SYNC100, 9-7
- PXIe-DSTAR<A..C>, 9-9

Q

- quadrature encoders, 8-21

R

- range, analog input
 - MIO X Series devices, 4-2
- real-time system integration bus, 9-4
- reciprocal frequency measurement, 8-13
- reference clock
 - 10 MHz, 9-3
 - external, 9-2
- referenced single-ended connections
 - using with floating signal sources
 - MIO X Series devices, 4-17
 - when to use with floating signal sources

- MIO X Series devices, 4-13
 - when to use with ground-referenced signal sources
 - MIO X Series devices, 4-19
 - related documentation, B-1
 - retriggerable single pulse generation, 8-29
 - routing
 - analog comparison event to an output terminal, 11-4
 - clock, 9-1
 - digital, 9-1
 - RSE configuration
 - MIO X Series devices, 4-17
 - RSE connections
 - using with floating signal sources
 - MIO X Series devices, 4-17
 - when to use with floating signal sources
 - MIO X Series devices, 4-13
 - when to use with ground-referenced signal sources
 - MIO X Series devices, 4-19
 - RTSI, 9-4
 - connector pinout, 3-7, 9-5
 - filters, 9-7
 - using as outputs, 9-6
 - using terminals as timing input signals, 9-6
 - rubber feet, 1-7
- S**
- sample clock
 - edge counting, 8-4
 - measurement, 8-23
 - scanning speed (MIO X Series devices), 4-8
 - SCC, 2-9
 - SCXI, 2-9
 - self-calibration, 1-4
 - semi-period measurement, 8-10
 - implicit buffered, 8-11
 - single, 8-11
 - sensors, 2-8
 - settings
 - analog input ground-reference
 - MIO X Series devices, 4-4
 - AO reference selection, 5-2
 - short high-quality cabling (MIO X Series devices), 4-7
 - signal conditioning
 - options, 2-9
 - signal connections
 - analog input
 - Simultaneous MIO X Series devices, 4-41
 - signal descriptions, 3-2
 - signal routing, RTSI bus, 9-4
 - signal sources
 - floating
 - MIO X Series devices, 4-12
 - Simultaneous MIO X Series devices, 4-41
 - ground-referenced
 - MIO X Series devices, 4-17
 - Simultaneous MIO X Series devices, 4-41
 - signals
 - AI Convert Clock, 4-27
 - AI Convert Clock Timebase, 4-30
 - AI Hold Complete Event, 4-30
 - Simultaneous MIO X Series devices, 4-50
 - AI Pause Trigger
 - MIO X Series devices, 4-34
 - Simultaneous MIO X Series devices, 4-55
 - AI Reference Trigger
 - MIO X Series devices, 4-32
 - Simultaneous MIO X Series devices, 4-53
 - AI Sample Clock
 - MIO X Series devices, 4-24
 - Simultaneous MIO X Series devices, 4-48
 - AI Sample Clock Timebase
 - MIO X Series devices, 4-26
 - Simultaneous MIO X Series devices, 4-49
 - AI Start Trigger
 - MIO X Series devices, 4-30
 - Simultaneous MIO X Series devices, 4-50

- analog input
 - MIO X Series devices, 4-22
 - Simultaneous MIO X Series devices, 4-45
- analog output, 5-5
- AO Pause Trigger, 5-7
- AO Sample Clock, 5-8
- AO Sample Clock Timebase, 5-10
- AO Start Trigger, 5-6
- Change Detection Event, 6-19
- connecting analog input
 - MIO X Series devices, 4-10
- connecting analog output, 5-5
- connecting counter, C-2
- connecting digital I/O, 6-24
- connecting PFI input, 7-4
- Counter *n* A, 8-39
- Counter *n* Aux, 8-38
- Counter *n* B, 8-39
- Counter *n* Gate, 8-37
- Counter *n* HW Arm, 8-39
- Counter *n* Internal Output, 8-41
- Counter *n* Sample Clock, 8-40
- Counter *n* Source, 8-36
- Counter *n* TC, 8-41
- Counter *n* Up_Down, 8-39
- Counter *n* Z, 8-39
- counters, 8-36
- DI Sample Clock, 6-4
- DO Sample Clock, 6-13
- exporting timing output using PFI terminals, 7-2
- FREQ OUT, 8-41
- Frequency Output, 8-41
 - minimizing output glitches, C-2
 - output, minimizing glitches on, 5-2
- simple pulse generation, 8-27
- single
 - point edge counting, 8-4
 - pulse generation, 8-27
 - retriggerable, 8-29
 - with start trigger, 8-27
 - pulse-width measurement, 8-6
 - semi-period measurement, 8-11
 - two-signal edge-separation measurement, 8-24
- single-ended connections
 - for floating signal sources
 - MIO X Series devices, 4-17
 - RSE configuration
 - MIO X Series devices, 4-17
- software, 1-3
 - AI applications
 - Simultaneous MIO X Series devices, 4-56
 - configuring AI ground-reference settings (MIO X Series devices), 4-6
 - programming devices, 2-10
- software-timed
 - acquisitions
 - MIO X Series devices, 4-9
 - Simultaneous MIO X Series devices, 4-38
 - generations, 5-3, 6-11
- specifications
 - device, 1-10
 - NI 6320, A-3
 - NI 6321/6341, A-7
 - NI 6345/6355, A-13, A-17, A-20
 - NI 6351/6361, A-26
 - NI 6353/6363, A-32
 - NI 6356/6366/6376, A-38
 - NI 6358/6368, A-40
 - NI 6358/6368/6378, A-40
 - NI 6365, A-43
 - NI 6374, A-45
 - NI 6375, A-48
- stacking, 1-7
- start trigger, 8-45
- static DIO, 6-2
 - using PFI terminals as, 7-3
- strain relief, 1-9
- switching from a large to a small input range (MIO X Series devices), 4-7
- synchronization modes
 - 100 MHz source, 8-47
 - external source greater than 40 MHz, 8-47
 - external source less than 40 MHz, 8-47

- internal source less than 40 MHz, 8-47
- synchronizing multiple devices, 9-3

T

- technical support, B-4
- terminal configuration
 - analog input
 - MIO X Series devices, 4-1
 - Simultaneous MIO X Series devices, 4-36
- terminals
 - connecting counter, 8-42
 - NI-DAQmx default counter, 8-42
- Timebase
 - 100 kHz, 9-2
 - 100 MHz, 9-2
 - 20 MHz, 9-2
- timed acquisitions
 - MIO X Series devices, 4-9
 - Simultaneous MIO X Series devices, 4-38
- timing output signals, exporting using PFI terminals, 7-2
- training, B-4
- transducers, 2-8
- trigger, 11-1
 - analog actions, 11-3
 - arm start, 8-45
 - pause, 8-45
 - PXI, 9-8
 - PXI_STAR, 9-8
 - Star Trigger, 9-8
 - start, 8-45
- triggering, 11-1
 - analog accuracy, 11-6
 - analog actions, 11-3
 - analog edge, 11-4
 - analog edge with hysteresis, 11-4
 - analog input
 - MIO X Series devices, 4-10
 - Simultaneous MIO X Series devices, 4-40
 - analog input channels, 11-3
 - analog types, 11-4
 - analog window, 11-6

- APFI <0, 1> terminals, 11-2
 - counter, 8-45
 - with a digital source, 11-1
 - with an analog source, 11-2
- troubleshooting
 - analog input, C-1
 - analog output, C-2
 - counters, C-2
- two-signal edge-separation measurement, 8-24
 - buffered, 8-25
 - single, 8-24
- types of analog triggers, 11-4

U

- USB BNC, 1-7
- USB BNC devices, 1-5
- USB Signal Stream, as a transfer method, 10-2
- USB X Series
 - bulk transfers, 10-2
 - cable strain relief, 1-9
 - desktop use, 1-7
 - device security, 1-9, 1-10
 - DIN rail mounting, 1-8
 - panel mounting, 1-7
 - security cable slot, 1-9, 1-10
 - USB cable strain relief, 1-9
 - wall mounting, 1-7
- using
 - low impedance sources (MIO X Series devices), 4-7
 - PFI terminals
 - as static digital I/Os, 7-3
 - as timing input signals, 7-2
 - to export timing output signals, 7-2
 - RTSI
 - as outputs, 9-6
 - terminals as timing input signals, 9-6
 - short high-quality cabling (MIO X Series devices), 4-7
 - the disk drive power connector (PCI Express), 3-6

W

waveform

- generation

 - digital, 6-13

 - signals, 5-5

wiring

- Simultaneous MIO X Series devices,
4-44

working voltage range

- Simultaneous MIO X Series devices,
4-3, 4-38

X

X Series

- accessories and cables, 1-10

- accessory options, 2-4

- cabling options, 2-4

- information, A-1

- pinouts, 1-10

- specifications, 1-10

- USB devices, 1-5

X1 encoding, 8-21

X2 encoding, 8-21

X4 encoding, 8-22