

## COMPREHENSIVE SERVICES

We offer competitive repair and calibration services, as well as easily accessible documentation and free downloadable resources.

## SELL YOUR SURPLUS

We buy new, used, decommissioned, and surplus parts from every NI series. We work out the best solution to suit your individual needs.

 Sell For Cash    Get Credit    Receive a Trade-In Deal

## OBSOLETE NI HARDWARE IN STOCK & READY TO SHIP

We stock **New**, **New Surplus**, **Refurbished**, and **Reconditioned** NI Hardware.



*Bridging the gap between the manufacturer and your legacy test system.*

 1-800-915-6216

 [www.apexwaves.com](http://www.apexwaves.com)

 [sales@apexwaves.com](mailto:sales@apexwaves.com)

*All trademarks, brands, and brand names are the property of their respective owners.*

**Request a Quote**

 **CLICK HERE**

**SCXI-1120**

# SCXI™-1120/D

## Introduction

---

This document contains information and step-by-step instructions for calibrating the National Instruments (NI) SCXI-1120 and SCXI-1120D modules.

### What Is Calibration?

*Calibration* consists of verifying the measurement accuracy of a module and adjusting for any measurement error. *Verification* is measuring the performance of the module and comparing these measurements to the factory specifications. During calibration, you supply and read voltage levels using external standards, then you adjust the module calibration circuitry. This circuitry compensates for any inaccuracies in the module, and returns the accuracy of the module to the factory specifications.

### Why Should You Calibrate?

The accuracy of electronic components drifts with time and temperature, which can affect measurement accuracy as a module ages. Calibration restores these components to their specified accuracy and ensures that the module still meets NI standards.

### How Often Should You Calibrate?

The measurement requirements of your application determine how often the SCXI-1120/D module needs to be calibrated to maintain accuracy. NI recommends that you perform a complete calibration at least once every year. You can shorten this interval to 90 days or six months based on the demands of your application.

# Equipment and Other Test Requirements

---

This section describes the test equipment, software, documentation, and test conditions required for calibrating the SCXI-1120/D modules.

## Test Equipment

Calibration requires a high-precision voltage source with at least 50 ppm accuracy and a multiranging 5 1/2 digit digital multimeter (DMM) with 15 ppm accuracy.

## Instruments

NI recommends the following instruments for calibrating SCXI-1120/D modules:

- Calibrator—Fluke 5700A
- DMM—NI 4060 or HP 34401A

If these instruments are not available, use the accuracy requirements listed previously to select substitute calibration instruments.

## Connectors

If you do not have custom connection hardware, you need the following connectors:

- Terminal block, such as the SCXI-1320
- Shielded 68-pin connector cable
- 50-pin ribbon cable
- 50-pin breakout box
- SCXI-1349 adapter

These components give easy access to the individual pins on the SCXI-1120/D module front and rear connectors.

## Software and Documentation

No special software or documentation is necessary to calibrate the SCXI-1120/D module. This calibration document contains all the information you need to complete the verification and adjustment procedures. If you would like more information on the module, refer to the *SCXI-1120/D User Manual*.

## Test Conditions

Follow these guidelines to optimize the connections and environment during calibration:

- Keep connections to the SCXI-1120/D module short. Long cables and wires act as antennae, picking up extra noise and thermal offsets that can affect measurements.
- Use shielded copper wire for all cable connections to the device. Use twisted-pair wire to eliminate noise and thermal offsets.
- Maintain the temperature between 18–28 °C.
- Keep relative humidity below 80%.
- Allow a warm-up time of at least 15 minutes for the SCXI-1120/D module to ensure the measurement circuitry is at a stable operating temperature.

## Calibration

---

The calibration procedure for the SCXI-1120/D module consists of the following steps:

1. Set up the module for testing.
2. Verify the existing operation of the module to determine whether it is operating within its specifications.
3. Adjust the module with respect to a known voltage source.
4. Verify that the module is operating within its specifications after adjustments.

## Setting Up the Module

Refer to Figures 1 and 2 while performing the following steps to set up the SCXI-1120/D module for verification:

1. Remove the grounding screw from the module.
2. Remove the cover on the module to access the potentiometers.

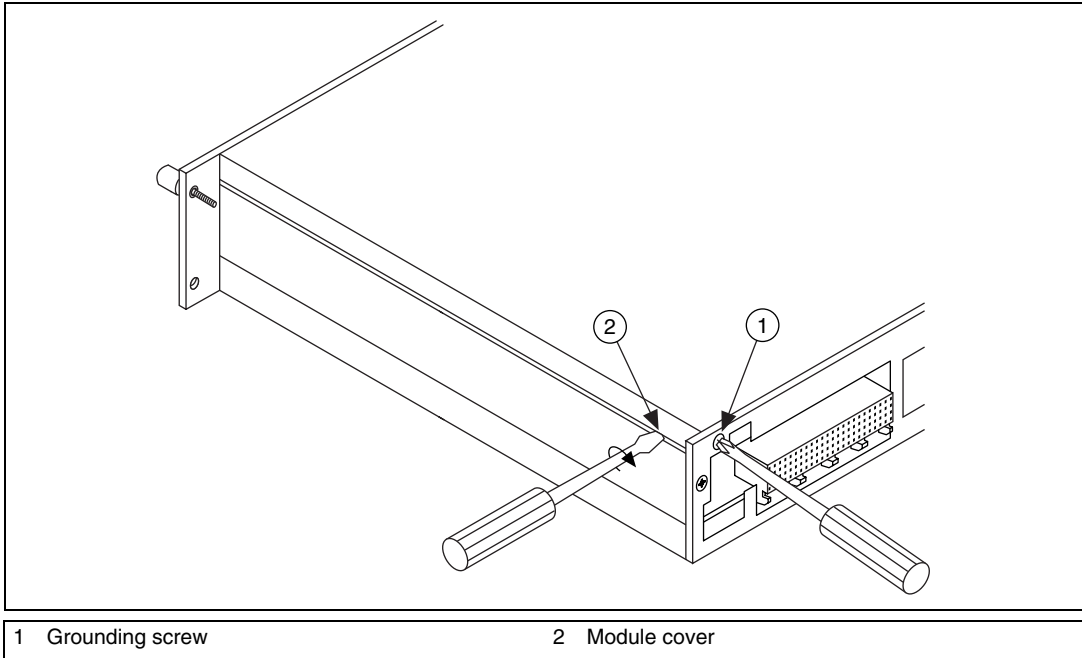

**Figure 1.** Grounding Screw and Module Cover Removal

3. Remove the side plate of the SCXI chassis.
4. Install the SCXI-1120/D into slot 4 of the SCXI chassis.

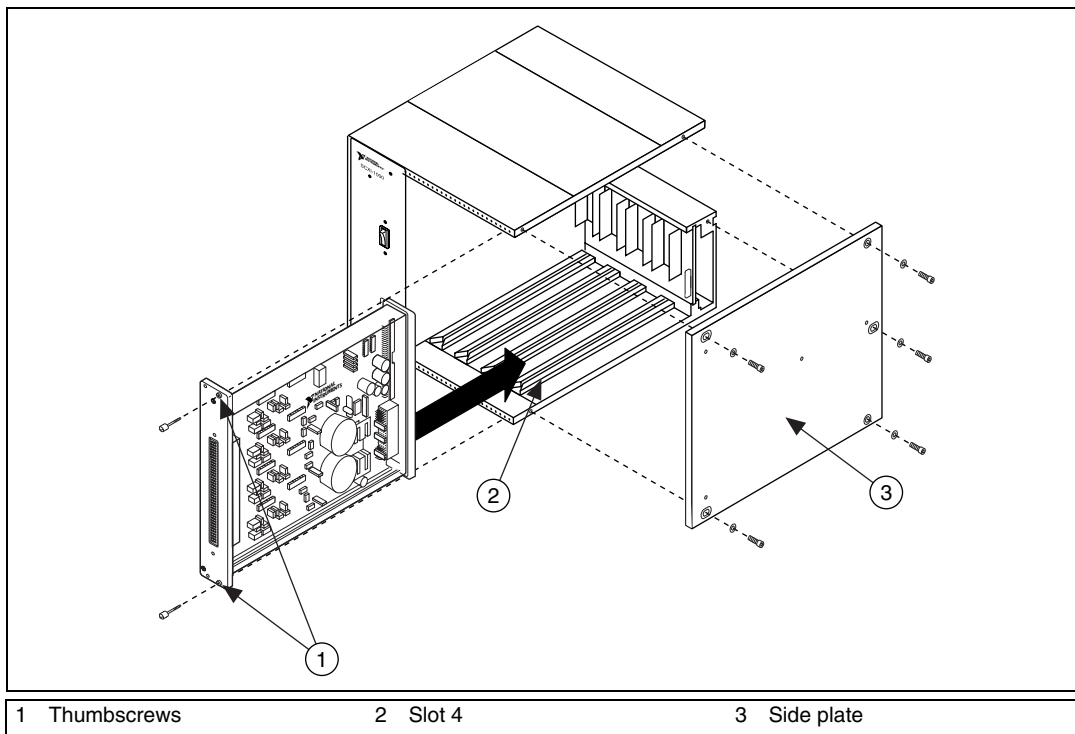

**Figure 2.** Side Plate Removal and Module Installation

The SCXI-1120/D module does not need to be connected to a data acquisition (DAQ) device. Leave the configuration of the digital jumpers W41–W43 and W46 unchanged because they do not affect this procedure.

## Configuring the Gain Jumpers

Each input channel has two user-configurable gain stages. The first-stage gain provides gains of 1, 10, 50, and 100. The second-stage gain provides gains of 1, 2, 5, 10, and 20. Table 1 shows the jumper reference designators for gain selection associated with each channel. Table 2 shows how to position each jumper to select the desired gain for each channel.

**Table 1.** Gain Jumper Reference Designators

Input Channel Number	First-Stage Gain Jumper	Second-Stage Gain Jumper
0	W1	W9
1	W2	W10
2	W3	W11

**Table 1.** Gain Jumper Reference Designators (Continued)

<b>Input Channel Number</b>	<b>First-Stage Gain Jumper</b>	<b>Second-Stage Gain Jumper</b>
3	W4	W12
4	W5	W13
5	W6	W14
6	W7	W15
7	W8	W16

**Table 2.** Gain Jumper Positions

<b>Gain</b>	<b>Setting</b>	<b>Jumper Position</b>
First Stage	1	D
	10	C
	50	B
	100	A (factory setting)
Second Stage	1	A
	2	B
	5	C
	10	D (factory setting)
	20	E

To change the gain setting of a specified channel on the module, move the appropriate jumper on the module to the position indicated in Table 2. Refer to Table 1 for jumper reference designators, and Figure 3 for the location of the jumpers.





The order of the settings for the first- and second-stage gain does not matter as long as the first-stage gain multiplied by the second-stage gain—multiplied by 0.5 when using the SCXI-1120D—equals the desired final gain value.

- SCXI-1120—To determine the overall gain of a given channel on the SCXI-1120 module:

$$\text{First-Stage Gain} \times \text{Second-Stage Gain} = \text{Overall Gain}$$

- SCXI-1120D—To determine the overall gain of a given channel on the SCXI-1120D module:

$$(\text{First-Stage Gain} \times \text{Second-Stage Gain}) \times 0.5 = \text{Overall Gain}$$

## Configuring the Filter Jumpers

Each input channel also has two user-configurable filter stages. The SCXI-1120 module ships in the 4 Hz position and the SCXI-1120/D module ships in the 4.5 kHz position. Refer to Table 3 or 4 to find the correct jumper setting for the desired cutoff frequency. Figure 3 shows the locations of the jumper blocks on the SCXI-1120/D modules. Verify that both filter stages are set to the same filter setting to ensure that you achieve the required bandwidth.

**Table 3.** SCXI-1120 Filter Jumper Settings

Input Channel Number	First Filter Jumper		Second Filter Jumper	
	4 Hz (Factory Setting)	10 kHz	4 Hz (Factory Setting)	10 kHz
0	W17-A	W17-B	W25	W26
1	W18-A	W18-B	W27	W28
2	W19-A	W19-B	W29	W30
3	W20-A	W20-B	W31	W32
4	W21-A	W21-B	W33	W34
5	W22-A	W22-B	W35	W36
6	W23-A	W23-B	W37	W38
7	W24-A	W24-B	W39	W40

**Table 4.** SCXI-1120D Filter Jumper Allocation

Input Channel Number	First Filter Jumper		Second Filter Jumper	
	4.5 kHz (Factory Setting)	22.5 kHz	4.5 kHz (Factory Setting)	22.5 kHz
0	W17-A	W17-B	W26	W25
1	W18-A	W18-B	W28	W27
2	W19-A	W19-B	W30	W29
3	W20-A	W20-B	W32	W31
4	W21-A	W21-B	W34	W33
5	W22-A	W22-B	W36	W35
6	W23-A	W23-B	W38	W37
7	W24-A	W24-B	W40	W39

## Verifying the Operation of the Module

The verification procedure determines how well the SCXI-1120/D module is meeting its specifications. You can use this information to select the appropriate calibration interval for your application. Refer to the [Setting Up the Module](#) section for information on how to configure the channel filter and channel gain.

Complete the following steps to verify the operation of the SCXI-1120/D module:

1. Read the [Test Conditions](#) section in this document.
2. Refer to Table 7 for the SCXI-1120 module or Table 8 for the SCXI-1120D module for all acceptable settings for the module. Although NI recommends verifying all ranges and gains, you can save time by checking only those ranges used in your application.
3. Set the channel filter for all channels on the module to 4 Hz for the SCXI-1120 module or 4.5 kHz for the SCXI-1120D module.
4. Set the channel gain on all channels to the gain you want to test, starting with the smallest gain available for the module. Available gains are shown in Tables 7 and 8.
5. Connect the calibrator to the analog input channel you are testing, starting with channel 0.

If you do not have an SCXI terminal block such as the SCXI-1320, refer to Table 5 to determine the pins on the 96-pin front connector that correspond to the positive and negative inputs of the specified channel.

For example, the positive input for channel 0 is pin A32, which is labeled *CH0+*. The negative input for channel 0 is pin C32, which is labeled *CH0-*.

**Table 5.** SCXI-1120/D Front Connector Pin Assignments

<b>Pin Number</b>	<b>Column A</b>	<b>Column B</b>	<b>Column C</b>
32	CH0+	NP	CH0-
31	NP	NP	NP
30	CH1+	NP	CH1-
29	NP	NP	NP
28	NC	NP	NC
27	NP	NP	NP
26	CH2+	NP	CH2-
25	NP	NP	NP
24	CH3+	NP	CH3-
23	NP	NP	NP
22	NC	NP	NC
21	NP	NP	NP
20	CH4+	NP	CH4-
19	NP	NP	NP
18	CH5+	NP	CH5-
17	NP	NP	NP
16	NC	NP	NC
15	NP	NP	NP
14	CH6+	NP	CH6-
13	NP	NP	NP
12	CH7+	NP	CH7-
11	NP	NP	NP
10	NC	NP	NC
9	NP	NP	NP
8	NC	NP	RSVD

**Table 5.** SCXI-1120/D Front Connector Pin Assignments (Continued)

Pin Number	Column A	Column B	Column C
7	NP	NP	NP
6	RSVD	NP	RSVD
5	NP	NP	NP
4	+5V	NP	MTEMP
3	NP	NP	NP
2	CHSGND	NP	DTEMP
1	NP	NP	NP

NP—No pin; NC—No connect

6. Connect the DMM to the output of the same channel to which the calibrator was connected in step 5. Refer to Figure 4 to determine the pins on the 50-pin rear connector that correspond to the positive and negative outputs for the specified channel. For example, the positive output for channel 0 is pin 3, which is labeled *MCH0+*. The negative output for channel 0 is pin 4, which is labeled *MCH0-*.

AOGND	1	2	AOGND
MCH0+	3	4	MCH0-
MCH1+	5	6	MCH1-
MCH2+	7	8	MCH2-
MCH3+	9	10	MCH3-
MCH4+	11	12	MCH4-
MCH5+	13	14	MCH5-
MCH6+	15	16	MCH6-
MCH7+	17	18	MCH7-
OUTREF	19	20	NC
NC	21	22	NC
NC	23	24	DIG GND
SERDATIN	25	26	SERDATOUT
DAQD*/A	27	28	NC
SLOT0SEL*	29	30	NC
NC	31	32	NC
DIG GND	33	34	NC
NC	35	36	SCANCLK
SERCLK	37	38	NC
NC	39	40	NC
NC	41	42	NC
RSVD	43	44	NC
NC	45	46	NC
NC	47	48	NC
NC	49	50	NC

**Figure 4.** SCXI-1120/D Rear Connector Pin Assignments

7. Set the calibrator voltage to the value specified by the Test Point entry listed in Table 7 for the SCXI-1120 module or Table 8 for the SCXI-1120D module.
8. Read the resulting output voltage on the DMM. If the output voltage result falls between the Upper Limit and the Lower Limit values, the module passed the test.
9. Repeat steps 5 through 8 for the remaining test points.
10. Repeat steps 5 through 9 for the remaining analog input channels.
11. Repeat steps 4 through 10 for the remaining gain settings specified in the appropriate table.
12. Repeat steps 3 through 11, but set the channel filter to 10 kHz for the SCXI-1120 module or 22.5 kHz for the SCXI-1120D module.

You have completed verifying the operation of the module.

## Adjusting Offset Null Values of the Module

Complete the following steps to adjust the offset null value:

1. Set the channel gain on all channels to a gain of 1. Set the filter value to 4 Hz for the SCXI-1120 module or 4.5 kHz for the SCXI-1120D module. Refer to the *Setting Up the Module* section in this document for information on how to set the channel gain.
2. Connect the calibrator to the analog input channel you want to adjust, starting with channel 0. Refer to Table 5 to determine the pins on the 96-pin front connector that correspond to the positive and negative inputs of the specified channel. For example, the positive input for channel 0 is pin A32, which is labeled *CHO+*. The negative input for channel 0 is pin C32, which is labeled *CHO-*.
3. Connect the DMM to the output of the same channel to which the calibrator was connected in step 2. Refer to Figure 4 to determine the pins on the 50-pin rear connector that correspond to the positive and negative outputs for the specified channel. For example, the positive output for channel 0 is pin 3, which is labeled *MCHO+*. The negative output for channel 0 is pin 4, which is labeled *MCHO-*.
4. Set the calibrator to output 0.0 V.
5. Adjust the output potentiometer of the channel until the DMM reading is  $0 \pm 3.0$  mV. Refer to Figure 3 for the potentiometer location and Table 6 for the potentiometer reference designator.

**Table 6.** Calibration Potentiometers Reference Designators

Input Channel Number	Input Null	Output Null
0	R08	R24
1	R10	R25
2	R12	R26
3	R14	R27
4	R16	R28
5	R18	R29
6	R20	R30
7	R21	R31

6. Set the channel gain on all channels to 1000.0.

7. Adjust the input potentiometer of channel 0 until the DMM reading is  $0 \pm 6.0$  mV. Refer to Figure 3 for the potentiometer location and Table 6 for the potentiometer reference designator.
8. Repeat steps 1 through 7 for the remaining analog inputs.

You have completed adjusting the module.

## Verifying Adjusted Values

After you complete the adjustment procedure, it is important to verify the accuracy of the adjusted values by repeating the procedure in the [Verifying the Operation of the Module](#) section. Verifying the adjusted values ensures the module is operating within its specifications after adjustments.



**Note** If the SCXI-1120/D module fails after calibration, return it to NI for repair or replacement.

# Specifications

Table 7 contains test specifications for SCXI-1120 modules. Table 8 contains test specifications for SCXI-1120D modules. If the module was calibrated within the last year, the output from the module should fall between the Upper Limit and Lower Limit values.

**Table 7.** SCXI-1120 Specifications

Gain	Test Point (V)	4Hz filter setting		10kHz filter setting	
		Upper Limit (V)	Lower Limit (V)	Upper Limit (V)	Lower Limit (V)
0.01 <sup>1</sup>	232.5	2.346996	2.303004	2.349248	2.300752
0.01 <sup>1</sup>	0	0.006888	-0.006888	0.009140	-0.009140
0.01 <sup>1</sup>	-232.5	-2.346996	-2.303004	-2.349248	-2.300752
0.02 <sup>1</sup>	186	3.751095	3.688905	3.753353	3.686647
0.02 <sup>1</sup>	0	0.006922	-0.006922	0.009180	-0.009180
0.02 <sup>1</sup>	-186	-3.751095	-3.688905	-3.753353	-3.686647
0.05 <sup>1</sup>	93	4.687000	4.613000	4.689236	4.610764
0.05 <sup>1</sup>	0	0.006784	-0.006784	0.009020	-0.009020
0.05 <sup>1</sup>	-93	-4.687000	-4.613000	-4.689236	-4.610764
0.1 <sup>1</sup>	46.5	4.686925	4.613075	4.689186	4.610814
0.1 <sup>1</sup>	0	0.006709	-0.006709	0.008970	-0.008970
0.1 <sup>1</sup>	-46.5	-4.686925	-4.613075	-4.689186	-4.610814
0.2 <sup>1</sup>	23.25	4.686775	4.613225	4.689056	4.610944
0.2 <sup>1</sup>	0	0.006559	-0.006559	0.008840	-0.008840
0.2 <sup>1</sup>	-23.25	-4.686775	-4.613225	-4.689056	-4.610944
0.5 <sup>1</sup>	9.3	4.686353	4.613647	4.688626	4.611374
0.5 <sup>1</sup>	0	0.006138	-0.006138	0.008410	-0.008410
0.5 <sup>1</sup>	-9.3	-4.686353	-4.613647	-4.688626	-4.611374
1	4.65	4.691704	4.608296	4.693926	4.606074
1	0	0.011488	-0.011488	0.013710	-0.013710
1	-4.65	-4.691704	-4.608296	-4.693926	-4.606074



**Table 7.** SCXI-1120 Specifications (Continued)

Gain	Test Point (V)	4Hz filter setting		10kHz filter setting	
		Upper Limit (V)	Lower Limit (V)	Upper Limit (V)	Lower Limit (V)
2	2.325	4.690653	4.609347	4.692876	4.607124
2	0	0.010437	-0.010437	0.012660	-0.012660
2	-2.325	-4.690653	-4.609347	-4.692876	-4.607124
5	0.93	4.690498	4.609502	4.692726	4.607274
5	0	0.010282	-0.010282	0.012510	-0.012510
5	-0.93	-4.690498	-4.609502	-4.692726	-4.607274
10	0.465	4.690401	4.609599	4.692626	4.607374
10	0	0.010185	-0.010185	0.012410	-0.012410
10	-0.465	-4.690401	-4.609599	-4.692626	-4.607374
20	0.2325	4.690139	4.609861	4.692416	4.607584
20	0	0.009924	-0.009924	0.012200	-0.012200
20	-0.2325	-4.690139	-4.609861	-4.692416	-4.607584
50	0.093	4.690046	4.609954	4.692331	4.607669
50	0	0.009831	-0.009831	0.012115	-0.012115
50	-0.093	-4.690046	-4.609954	-4.692331	-4.607669
100	0.0465	4.689758	4.610242	4.692066	4.607934
100	0	0.009542	-0.009542	0.011850	-0.011850
100	-0.0465	-4.689758	-4.610242	-4.692066	-4.607934
200	0.02325	4.689464	4.610536	4.691936	4.608064
200	0	0.009248	-0.009248	0.011720	-0.011720
200	-0.02325	-4.689464	-4.610536	-4.691936	-4.608064
250	0.0186	4.689313	4.610687	4.692016	4.607984
250	0	0.009097	-0.009097	0.011800	-0.011800
250	-0.0186	-4.689313	-4.610687	-4.692016	-4.607984
500	0.0093	4.689443	4.610557	4.692731	4.607269
500	0	0.009227	-0.009227	0.012515	-0.012515

**Table 7.** SCXI-1120 Specifications (Continued)

Gain	Test Point (V)	4Hz filter setting		10kHz filter setting	
		Upper Limit (V)	Lower Limit (V)	Upper Limit (V)	Lower Limit (V)
500	-0.0093	-4.689443	-4.610557	-4.692731	-4.607269
1000	0.00465	4.693476	4.606524	4.698796	4.601204
1000	0	0.013260	-0.013260	0.018580	-0.018580
1000	-0.00465	-4.693476	-4.606524	-4.698796	-4.601204
2000	0.002325	4.703044	4.596956	4.712556	4.587444
2000	0	0.022828	-0.022828	0.032340	-0.032340
2000	-0.002325	-4.703044	-4.596956	-4.712556	-4.587444

<sup>1</sup>Value available only when used with the SCXI-1327 high-voltage terminal block

**Table 8.** SCXI-1120D Specifications

Gain	Test Point (V)	4.5KHz filter setting		22.5KHz filter setting	
		Upper Limit (V)	Lower Limit (V)	Upper Limit (V)	Lower Limit (V)
0.01 <sup>1</sup>	232.5	2.351764	2.298236	2.365234	2.284766
0.01 <sup>1</sup>	0	0.006230	-0.006230	0.019700	-0.019700
0.01 <sup>1</sup>	-232.5	-2.351764	-2.298236	-2.365234	-2.284766
0.025 <sup>1</sup>	186	4.698751	4.601249	4.733819	4.566181
0.025 <sup>1</sup>	0	0.007683	-0.007683	0.042750	-0.042750
0.025 <sup>1</sup>	-186	-4.698751	-4.601249	-4.733819	-4.566181
0.05 <sup>1</sup>	93	4.697789	4.602211	4.768769	4.531231
0.05 <sup>1</sup>	0	0.006720	-0.006720	0.077700	-0.077700
0.05 <sup>1</sup>	-93	-4.697789	-4.602211	-4.768769	-4.531231
0.1 <sup>1</sup>	46.5	4.698899	4.601101	4.841289	4.458711
0.1 <sup>1</sup>	0	0.007830	-0.007830	0.150220	-0.150220
0.1 <sup>1</sup>	-46.5	-4.698899	-4.601101	-4.841289	-4.458711
0.25 <sup>1</sup>	18.6	4.701669	4.598331	5.028819	4.271181

**Table 8.** SCXI-1120D Specifications (Continued)

Gain	Test Point (V)	4.5KHz filter setting		22.5KHz filter setting	
		Upper Limit (V)	Lower Limit (V)	Upper Limit (V)	Lower Limit (V)
0.25 <sup>1</sup>	0	0.010600	-0.010600	0.337750	-0.337750
0.25 <sup>1</sup>	-18.6	-4.701669	-4.598331	-5.028819	-4.271181
0.5	9.3	4.697331	4.602669	4.703726	4.596274
0.5	0	0.006355	-0.006355	0.012750	-0.012750
0.5	-9.3	-4.697331	-4.602669	-4.703726	-4.596274
1	4.65	4.697416	4.602584	4.710876	4.589124
1	0	0.006440	-0.006440	0.019900	-0.019900
1	-4.65	-4.697416	-4.602584	-4.710876	-4.589124
2.5	1.86	4.697883	4.602117	4.732426	4.567574
2.5	0	0.006908	-0.006908	0.041450	-0.041450
2.5	-1.86	-4.697883	-4.602117	-4.732426	-4.567574
5	0.93	4.698726	4.601274	4.768726	4.531274
5	0	0.007750	-0.007750	0.077750	-0.077750
5	-0.93	-4.698726	-4.601274	-4.768726	-4.531274
10	0.465	4.700796	4.599204	4.841236	4.458764
10	0	0.009820	-0.009820	0.150260	-0.150260
10	-0.465	-4.700796	-4.599204	-4.841236	-4.458764
25	0.18	5.070004	3.929996	4.870004	4.129996
25	0	0.530350	-0.530350	0.330350	-0.330350
25	-0.18	-5.070004	-3.929996	-4.870004	-4.129996
50	0.086	4.360392	4.239608	4.825892	3.774108
50	0	0.022500	-0.022500	0.488000	-0.488000
50	-0.086	-4.360392	-4.239608	-4.825892	-3.774108
100	0.038	3.879624	3.720376	4.810624	2.789376
100	0	0.039800	-0.039800	0.970800	-0.970800
100	-0.038	-3.879624	-3.720376	-4.810624	-2.789376

**Table 8.** SCXI-1120D Specifications (Continued)

<b>Gain</b>	<b>Test Point (V)</b>	<b>4.5KHz filter setting</b>		<b>22.5KHz filter setting</b>	
		<b>Upper Limit (V)</b>	<b>Lower Limit (V)</b>	<b>Upper Limit (V)</b>	<b>Lower Limit (V)</b>
250	0.0125	3.277438	2.972563	4.830188	1.419813
250	0	0.091500	-0.091500	0.056751	-1.644250
250	-0.0125	-3.277438	-2.972563	-4.830188	-1.419813
500	0.006	3.273770	2.726230	4.810770	1.189230
500	0	0.176000	-0.176000	1.713000	-1.713000
500	-0.006	-3.273770	-2.726230	-4.810770	-1.189230
1000	0.0029	3.416058	2.383942	4.895058	0.904942
1000	0	0.342000	-0.342000	1.821000	-1.821000
1000	-0.0029	-3.416058	-2.383942	-4.895058	-0.904942
<sup>1</sup> Value available only when used with the SCXI-1327 high-voltage terminal block					