

COMPREHENSIVE SERVICES

We offer competitive repair and calibration services, as well as easily accessible documentation and free downloadable resources.

SELL YOUR SURPLUS

We buy new, used, decommissioned, and surplus parts from every NI series. We work out the best solution to suit your individual needs.

 Sell For Cash  Get Credit  Receive a Trade-In Deal

OBSOLETE NI HARDWARE IN STOCK & READY TO SHIP

We stock **New**, **New Surplus**, **Refurbished**, and **Reconditioned** NI Hardware.



Bridging the gap between the manufacturer and your legacy test system.

 1-800-915-6216

 www.apexwaves.com

 sales@apexwaves.com

All trademarks, brands, and brand names are the property of their respective owners.

Request a Quote

 **CLICK HERE**

DAQCard-AI-16XE-50

DAQ

DAQCard™ E Series User Manual

Multifunction I/O Cards for PCMCIA

Internet Support

E-mail: support@natinst.com

FTP Site: <ftp.natinst.com>

Web Address: <http://www.natinst.com>

Bulletin Board Support

BBS United States: 512 794 5422

BBS United Kingdom: 01635 551422

BBS France: 01 48 65 15 59

Fax-on-Demand Support

512 418 1111

Telephone Support (USA)

Tel: 512 795 8248

Fax: 512 794 5678

International Offices

Australia 03 9879 5166, Austria 0662 45 79 90 0, Belgium 02 757 00 20, Brazil 011 284 5011,
Canada (Ontario) 905 785 0085, Canada (Québec) 514 694 8521, China 0755 3904939, Denmark 45 76 26 00,
Finland 09 725 725 11, France 01 48 14 24 24, Germany 089 741 31 30, Hong Kong 2645 3186,
India 91805275406, Israel 03 6120092, Italy 02 413091, Japan 03 5472 2970, Korea 02 596 7456,
Mexico (D.F.) 5 280 7625, Mexico (Monterrey) 8 357 7695, Netherlands 0348 433466, Norway 32 27 73 00,
Singapore 2265886, Spain (Madrid) 91 640 0085, Spain (Barcelona) 93 582 0251, Sweden 08 587 895 00,
Switzerland 056 200 51 51, Taiwan 02 2377 1200, United Kingdom 01635 523545

National Instruments Corporate Headquarters

6504 Bridge Point Parkway Austin, Texas 78730-5039 USA Tel: 512 794 0100

Important Information

Warranty

The DAQCard E Series cards are warranted against defects in materials and workmanship for a period of one year from the date of shipment, as evidenced by receipts or other documentation. National Instruments will, at its option, repair or replace equipment that proves to be defective during the warranty period. This warranty includes parts and labor.

The media on which you receive National Instruments software are warranted not to fail to execute programming instructions, due to defects in materials and workmanship, for a period of 90 days from date of shipment, as evidenced by receipts or other documentation. National Instruments will, at its option, repair or replace software media that do not execute programming instructions if National Instruments receives notice of such defects during the warranty period. National Instruments does not warrant that the operation of the software shall be uninterrupted or error free.

A Return Material Authorization (RMA) number must be obtained from the factory and clearly marked on the outside of the package before any equipment will be accepted for warranty work. National Instruments will pay the shipping costs of returning to the owner parts which are covered by warranty.

National Instruments believes that the information in this document is accurate. The document has been carefully reviewed for technical accuracy. In the event that technical or typographical errors exist, National Instruments reserves the right to make changes to subsequent editions of this document without prior notice to holders of this edition. The reader should consult National Instruments if errors are suspected. In no event shall National Instruments be liable for any damages arising out of or related to this document or the information contained in it.

EXCEPT AS SPECIFIED HEREIN, NATIONAL INSTRUMENTS MAKES NO WARRANTIES, EXPRESS OR IMPLIED, AND SPECIFICALLY DISCLAIMS ANY WARRANTY OF MERCHANTABILITY OR FITNESS FOR A PARTICULAR PURPOSE. CUSTOMER'S RIGHT TO RECOVER DAMAGES CAUSED BY FAULT OR NEGLIGENCE ON THE PART OF NATIONAL INSTRUMENTS SHALL BE LIMITED TO THE AMOUNT THEREOF PAID BY THE CUSTOMER. NATIONAL INSTRUMENTS WILL NOT BE LIABLE FOR DAMAGES RESULTING FROM LOSS OF DATA, PROFITS, USE OF PRODUCTS, OR INCIDENTAL OR CONSEQUENTIAL DAMAGES, EVEN IF ADVISED OF THE POSSIBILITY THEREOF. This limitation of the liability of National Instruments will apply regardless of the form of action, whether in contract or tort, including negligence. Any action against National Instruments must be brought within one year after the cause of action accrues. National Instruments shall not be liable for any delay in performance due to causes beyond its reasonable control. The warranty provided herein does not cover damages, defects, malfunctions, or service failures caused by owner's failure to follow the National Instruments installation, operation, or maintenance instructions; owner's modification of the product; owner's abuse, misuse, or negligent acts; and power failure or surges, fire, flood, accident, actions of third parties, or other events outside reasonable control.

Copyright

Under the copyright laws, this publication may not be reproduced or transmitted in any form, electronic or mechanical, including photocopying, recording, storing in an information retrieval system, or translating, in whole or in part, without the prior written consent of National Instruments Corporation.

Trademarks

DAQCard™, DAQPad™, DAQ-STC™, LabVIEW™, NI-DAQ™, NI-PGIA™, and SCXI™ are trademarks of National Instruments Corporation.

Product and company names mentioned herein are trademarks or trade names of their respective companies.

WARNING REGARDING MEDICAL AND CLINICAL USE OF NATIONAL INSTRUMENTS PRODUCTS

National Instruments products are not designed with components and testing intended to ensure a level of reliability suitable for use in treatment and diagnosis of humans. Applications of National Instruments products involving medical or clinical treatment can create a potential for accidental injury caused by product failure, or by errors on the part of the user or application designer. Any use or application of National Instruments products for or involving medical or clinical treatment must be performed by properly trained and qualified medical personnel, and all traditional medical safeguards, equipment, and procedures that are appropriate in the particular situation to prevent serious injury or death should always continue to be used when National Instruments products are being used. National Instruments products are NOT intended to be a substitute for any form of established process, procedure, or equipment used to monitor or safeguard human health and safety in medical or clinical treatment.

Contents

About This Manual

Organization of This Manual	xi
Conventions Used in This Manual	xii
National Instruments Documentation	xiii
Related Documentation.....	xiv
Customer Communication	xiv

Chapter 1

Introduction

About the DAQCard E Series	1-1
What You Need to Get Started	1-2
Software Programming Choices	1-2
LabVIEW and LabWindows/CVI Application Software	1-2
NI-DAQ Driver Software	1-3
Register-Level Programming	1-4
Optional Equipment	1-5
Custom Cabling	1-5
Unpacking	1-6

Chapter 2

Installation and Configuration

Installation	2-1
Configuration	2-3

Chapter 3

Hardware Overview

Analog Input	3-2
Input Mode	3-2
Input Polarity and Input Range.....	3-3
Considerations for Selecting Input Ranges	3-5
Dither	3-6
Multichannel Scanning Considerations	3-7
Analog Trigger.....	3-9
Digital I/O	3-12
Timing Signal Routing.....	3-12
Programmable Function Inputs	3-13
DAQCard Clocks.....	3-13

Chapter 4

Signal Connections

I/O Connector	4-1
Analog Input Signal Connections	4-8
Types of Signal Sources	4-10
Floating Signal Sources	4-10
Ground-Referenced Signal Sources	4-10
Input Configurations	4-10
Differential Connection Considerations (DIFF Input Configuration)	4-12
Differential Connections for Ground-Referenced Signal Sources ...	4-13
Differential Connections for Nonreferenced or Floating Signal Sources	4-14
Single-Ended Connection Considerations	4-16
Single-Ended Connections for Floating Signal Sources (RSE Configuration)	4-17
Single-Ended Connections for Grounded Signal Sources (NRSE Configuration)	4-17
Common-Mode Signal Rejection Considerations	4-18
Digital I/O Signal Connections	4-19
Power Connections	4-20
Timing Connections	4-20
Programmable Function Input Connections	4-21
Data Acquisition Timing Connections	4-22
SCANCLK Signal	4-23
EXTSTROBE* Signal	4-23
TRIG1 Signal	4-24
TRIG2 Signal	4-25
STARTSCAN Signal	4-27
CONVERT* Signal	4-29
AIGATE Signal	4-30
SISOURCE Signal	4-31
UISOURCE Signal	4-32
General-Purpose Timing Signal Connections	4-33
GPCTR0_SOURCE Signal	4-33
GPCTR0_GATE Signal	4-34
GPCTR0_OUT Signal	4-35
GPCTR0_UP_DOWN Signal	4-35
GPCTR1_SOURCE Signal	4-35
GPCTR1_GATE Signal	4-36
GPCTR1_OUT Signal	4-37
GPCTR1_UP_DOWN Signal	4-38
FREQ_OUT Signal	4-39

Field Wiring Considerations4-39

Chapter 5 Calibration

Loading Calibration Constants5-1
Self-Calibration.....5-2
External Calibration.....5-2
Other Considerations5-3

Appendix A Specifications

Appendix B Optional Cable Connector Descriptions

Appendix C PC Card Questions and Answers

Appendix D Common Questions

Appendix E Power-Management Modes

Appendix F Customer Communication

Glossary

Index

Figures

Figure 1-1.	The Relationship between the Programming Environment, NI-DAQ, and Your Hardware.....	1-4
Figure 2-1.	A Typical Configuration for the DAQCard E Series Card.....	2-2
Figure 3-1.	DAQCard-AI-16E-4 Block Diagram.....	3-1
Figure 3-2.	DAQCard-AI-16XE-50 Block Diagram.....	3-2
Figure 3-3.	Dither.....	3-7
Figure 3-4.	Analog Trigger Block Diagram.....	3-9
Figure 3-5.	Below-Low-Level Analog Triggering Mode.....	3-10
Figure 3-6.	Above-High-Level Analog Triggering Mode.....	3-10
Figure 3-7.	Inside-Region Analog Triggering Mode.....	3-10
Figure 3-8.	High-Hysteresis Analog Triggering Mode.....	3-11
Figure 3-9.	Low-Hysteresis Analog Triggering Mode.....	3-11
Figure 3-10.	CONVERT* Signal Routing.....	3-12
Figure 4-1.	I/O Connector Pin Assignment for the DAQCard-AI-16E-4 and DAQCard-AI-16XE-50.....	4-2
Figure 4-2.	DAQCard E Series PGIA.....	4-9
Figure 4-3.	Summary of Analog Input Connections.....	4-11
Figure 4-4.	Differential Input Connections for Ground-Referenced Signals.....	4-13
Figure 4-5.	Differential Input Connections for Nonreferenced Signals.....	4-14
Figure 4-6.	Single-Ended Input Connections for Nonreferenced or Floating Signals.....	4-17
Figure 4-7.	Single-Ended Input Connections for Ground-Referenced Signals.....	4-18
Figure 4-8.	Digital I/O Connections.....	4-19
Figure 4-9.	Timing I/O Connections.....	4-21
Figure 4-10.	Typical Posttriggered Acquisition.....	4-22
Figure 4-11.	Typical Pretriggered Acquisition.....	4-23
Figure 4-12.	SCANCLK Signal Timing.....	4-23
Figure 4-13.	EXTSTROBE* Signal Timing.....	4-24
Figure 4-14.	TRIG1 Input Signal Timing.....	4-25
Figure 4-15.	TRIG1 Output Signal Timing.....	4-25
Figure 4-16.	TRIG2 Input Signal Timing.....	4-26
Figure 4-17.	TRIG2 Output Signal Timing.....	4-26
Figure 4-18.	STARTSCAN Input Signal Timing.....	4-27
Figure 4-19.	STARTSCAN Output Signal Timing.....	4-28
Figure 4-20.	CONVERT* Input Signal Timing.....	4-29
Figure 4-21.	CONVERT* Output Signal Timing.....	4-29
Figure 4-22.	SISOURCE Signal Timing.....	4-31
Figure 4-23.	UISOURCE Signal Timing.....	4-32
Figure 4-24.	GPCTR0_SOURCE Signal Timing.....	4-33

Figure 4-25.	GPCTR0_GATE Signal Timing in Edge-Detection Mode.....	4-34
Figure 4-26.	GPCTR0_OUT Signal Timing.....	4-35
Figure 4-27.	GPCTR1_SOURCE Signal Timing.....	4-36
Figure 4-28.	GPCTR1_GATE Signal Timing in Edge-Detection Mode.....	4-37
Figure 4-29.	GPCTR1_OUT Signal Timing.....	4-37
Figure 4-30.	GPCTR Timing Summary.....	4-38
Figure B-1.	68-Pin AI Connector Pin Assignments.....	B-2
Figure B-2.	50-Pin AI Connector Pin Assignments.....	B-3

Tables

Table 3-1.	Available Input Configurations for the DAQCard E Series.....	3-3
Table 3-2.	Actual Range and Measurement Precision.....	3-4
Table 3-3.	Actual Range and Measurement Precision, DAQCard-AI-16XE-50.....	3-5
Table 4-1.	I/O Connector Signal Descriptions.....	4-3
Table 4-2.	I/O Signal Summary, DAQCard-AI-16E-4.....	4-5
Table 4-3.	I/O Signal Summary, DAQCard-AI-16XE-50.....	4-6
Table E-1.	DAQCard E Series Power-Management Modes.....	E-2

About This Manual

This manual describes the electrical and mechanical aspects of each card in the DAQCard E Series product line and contains information concerning their operation and programming. Unless otherwise noted, text applies to all cards in the DAQCard E Series.

The DAQCard E Series includes the following cards:

- DAQCard-AI-16E-4
- DAQCard-AI-16XE-50

The DAQCard E Series cards are high-performance multifunction analog, digital, and timing I/O cards for computers with PCMCIA slots compliant with rev. 2.1 of the PCMCIA specifications. Supported functions include analog input, analog output, digital I/O, and timing I/O.

Organization of This Manual

The *DAQCard E Series User Manual* is organized as follows:

- Chapter 1, *Introduction*, describes the DAQCard E Series cards, lists what you need to get started, describes the optional software and optional equipment, and explains how to unpack your DAQCard E Series card.
- Chapter 2, *Installation and Configuration*, explains how to install and configure your DAQCard E Series card.
- Chapter 3, *Hardware Overview*, presents an overview of the hardware functions on your DAQCard E Series card.
- Chapter 4, *Signal Connections*, describes how to make input and output signal connections to your DAQCard E Series card via the DAQCard I/O connector.
- Chapter 5, *Calibration*, discusses the calibration procedures for your DAQCard E Series card.
- Appendix A, *Specifications*, lists the specifications for each DAQCard in the DAQCard E Series.
- Appendix B, *Optional Cable Connector Descriptions*, describes the connectors on the optional cables for the DAQCard E Series cards.
- Appendix C, *PC Card Questions and Answers*, contains a list of common questions and answers relating to PC Card operation.

- Appendix D, *Common Questions*, contains a list of commonly asked questions and their answers relating to usage and special features of your DAQCard E Series card.
- Appendix E, *Power-Management Modes*, describes the power management modes of the DAQCard E Series cards.
- Appendix F, *Customer Communication*, contains forms you can use to request help from National Instruments or to comment on our products.
- The *Glossary* contains an alphabetical list and description of terms used in this manual, including abbreviations, acronyms, metric prefixes, mnemonics, and symbols.
- The *Index* alphabetically lists topics covered in this manual, including the page where you can find the topic.

Conventions Used in This Manual

The following conventions are used in this manual.

◆	The ◆ indicates that the text following it applies only to specific DAQCard E Series boards.
< >	Angle brackets containing numbers separated by an ellipsis represent a range of values associated with a bit, port, or signal name (for example, ACH<0..7> stands for ACH0 through ACH7).
bold	Bold text denotes parameters, menus, menu items, dialog box buttons or options, and error messages.
<i>bold italic</i>	Bold italic text denotes a note, caution, or warning.
<i>italic</i>	Italic text denotes emphasis on a specific DAQCard in the DAQCard E Series or on other important information, a cross reference, or an introduction to a key concept.
monospace	Text in this font denotes text or characters that are to be literally input from the keyboard, sections of code, programming examples, and syntax examples. This font is also used for the proper names of disk drives, paths, directories, programs, subprograms, subroutines, device names, functions, operations, variables, filenames, and extensions, and for statements and comments taken from program code.
NI-DAQ	NI-DAQ refers to NI-DAQ software unless otherwise noted.

PC Card	PC Card refers to a PCMCIA card.
SCXI	SCXI stands for Signal Conditioning eXtensions for Instrumentation and is a National Instruments product line designed to perform front-end signal conditioning for National Instruments plug-in DAQ boards.

National Instruments Documentation

The *DAQCard E Series User Manual* is one piece of the documentation set for your DAQ system. You could have any of several types of manuals depending on the hardware and software in your system. Use the manuals you have as follows:

- *Getting Started with SCXI*—If you are using SCXI, this is the first manual you should read. It gives an overview of the SCXI system and contains the most commonly needed information for the modules, chassis, and software.
- Your SCXI hardware user manuals—If you are using SCXI, read these manuals next for detailed information about signal connections and module configuration. They also explain in greater detail how the module works and contain application hints.
- Your DAQ hardware user manuals—These manuals have detailed information about the DAQ hardware that plugs into or is connected to your computer. Use these manuals for hardware installation and configuration instructions, specification information about your DAQ hardware, and application hints.
- Software documentation—You might have several sets of software documentation, including LabVIEW, LabWindows/CVI, and NI-DAQ. After you have set up your hardware system, use either the application software (LabVIEW or LabWindows/CVI) or the NI-DAQ documentation to help you write your application. If you have a large and complicated system, it is worthwhile to look through the software documentation before you configure your hardware.
- Accessory installation guides or manuals—If you are using accessory products, read the terminal block and cable assembly installation guides. They explain how to physically connect the relevant pieces of the system. Consult these guides when you are making your connections.
- SCXI chassis manuals—If you are using SCXI, read these manuals for maintenance information on the chassis and installation instructions.

Related Documentation

The following National Instruments document contains information you may find helpful:

- *DAQCard E Series Register-Level Programmer Manual*

This manual is available by request. If you are using NI-DAQ, LabVIEW, or LabWindows/CVI, you should not need the register-level programming manual.

Customer Communication

National Instruments wants to receive your comments on our products and manuals. We are interested in the applications you develop with our products, and we want to help if you have problems with them. To make it easy for you to contact us, this manual contains comment and configuration forms for you to complete. These forms are in Appendix F, *Customer Communication*, at the end of this manual.

Introduction

This chapter describes the DAQCard E Series cards, lists what you need to get started, describes the optional software and optional equipment, and explains how to unpack your DAQCard E Series card.

About the DAQCard E Series

Thank you for buying a National Instruments DAQCard E Series card. The DAQCard E Series cards are multifunction analog, digital, and timing I/O cards for computers equipped with Type II PCMCIA slots. This family of cards features 12-bit and 16-bit ADCs with eight lines of TTL-compatible digital I/O, and two 24-bit counter/timers for timing I/O.

The DAQCard E Series cards use the National Instruments DAQ-STC system timing controller for time-related functions. The DAQ-STC consists of three timing groups that control analog input, analog output, and general-purpose counter/timer functions. These groups include a total of seven 24-bit and three 16-bit counters and a maximum timing resolution of 50 ns.

The DAQCard E Series cards can interface to an SCXI system so that you can acquire over 3,000 analog signals from thermocouples, RTDs, strain gauges, voltage sources, and current sources. You can also acquire or generate digital signals for communication and control. SCXI is the instrumentation front end for plug-in DAQ boards.

Detailed specifications for the DAQCard E Series cards are in Appendix A, *Specifications*.

What You Need to Get Started

To set up and use your DAQCard E Series card, you will need the following:

- One of the following cards:
 - DAQCard-AI-16E-4
 - DAQCard-AI-16XE-50
- DAQCard E Series User Manual*
- One of the following software packages and documentation
 - NI-DAQ
 - LabVIEW
 - LabWindows/CVI
- Your computer

Software Programming Choices

There are several options to choose from when programming your National Instruments DAQ and SCXI hardware. You can use LabVIEW, LabWindows/CVI, NI-DAQ, or register-level programming.

LabVIEW and LabWindows/CVI Application Software

LabVIEW and LabWindows/CVI are innovative program development software packages for data acquisition and control applications. LabVIEW uses graphical programming, whereas LabWindows/CVI enhances traditional programming languages. Both packages include extensive libraries for data acquisition, instrument control, data analysis, and graphical data presentation.

LabVIEW features interactive graphics, a state-of-the-art user interface, and a powerful graphical programming language. The LabVIEW Data Acquisition VI Library, a series of VIs for using LabVIEW with National Instruments DAQ hardware, is included with LabVIEW. The LabVIEW Data Acquisition VI Library is functionally equivalent to the NI-DAQ software.

LabWindows/CVI features interactive graphics, a state-of-the-art user interface, and uses the ANSI standard C programming language. The LabWindows/CVI Data Acquisition Library, a series of functions for using LabWindows/CVI with National Instruments DAQ hardware, is included with the NI-DAQ software kit. The LabWindows/CVI Data Acquisition Library is functionally equivalent to the NI-DAQ software.

Using LabVIEW or LabWindows/CVI software will greatly reduce the development time for your data acquisition and control application.



Note

LabWindows/CVI is only available for the Windows and Sun SPARCstation platforms.

NI-DAQ Driver Software

The NI-DAQ driver software is included at no charge with all National Instruments DAQ hardware. NI-DAQ is not packaged with signal conditioning or accessory products. NI-DAQ has an extensive library of functions that you can call from your application programming environment. These functions include routines for analog input (A/D conversion), buffered data acquisition (high-speed A/D conversion), analog output (D/A conversion), waveform generation (timed D/A conversion), digital I/O, counter/timer operations, SCXI, RTSI, calibration, messaging, and acquiring data to extended memory.

NI-DAQ has both high-level DAQ I/O functions for maximum ease of use and low-level DAQ I/O functions for maximum flexibility and performance. Examples of high-level functions are streaming data to disk or acquiring a certain number of data points. An example of a low-level function is writing directly to registers on the DAQ device. NI-DAQ does not sacrifice the performance of National Instruments DAQ devices because it lets multiple devices operate at their peak performance.

NI-DAQ also internally addresses many of the complex issues between the computer and the DAQ hardware such as programming interrupts. NI-DAQ maintains a consistent software interface among its different versions so that you can change platforms with minimal modifications to your code. Whether you are using conventional programming languages, LabVIEW, or LabWindows/CVI, your application uses the NI-DAQ driver software, as illustrated in Figure 1-1.



Note

The IVI-DAQ language interfaces are not currently available on the Macintosh platform.

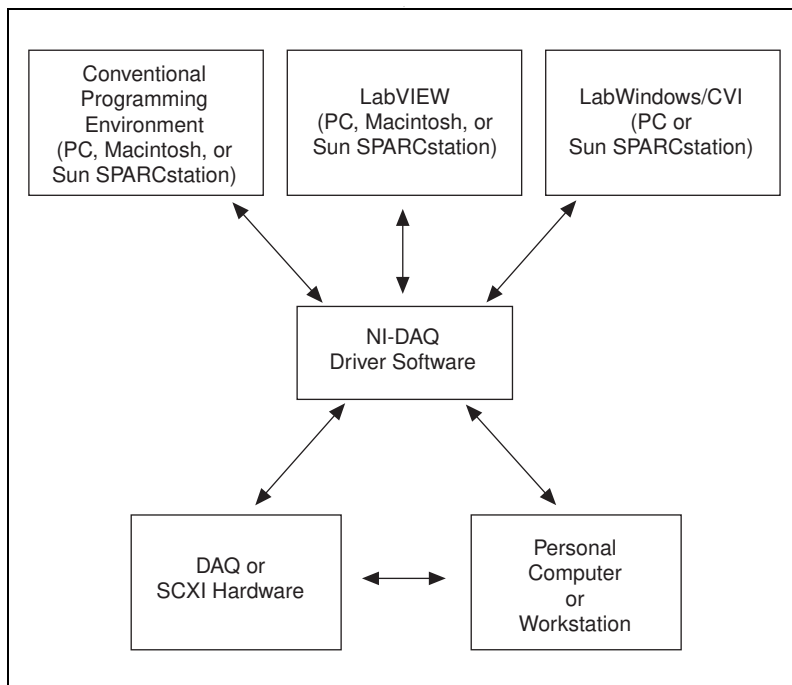

Figure 1-1. The Relationship between the Programming Environment, NI-DAQ, and Your Hardware

You can use your DAQCard E Series card, together with other PCI, PXI, PC, AT, DAQCard, and DAQPad Series DAQ and SCXI hardware, with NI-DAQ software.

Register-Level Programming

The final option for programming any National Instruments DAQ hardware is to write register-level software. Writing register-level programming software can be very time-consuming and inefficient and is not recommended for most users.

Even if you are an experienced register-level programmer, consider using NI-DAQ, LabVIEW, or LabWindows/CVI to program your National Instruments DAQ hardware. Using the NI-DAQ, LabVIEW, or LabWindows/CVI software is as easy and as flexible as register-level programming and can save weeks of development time.

Optional Equipment

National Instruments offers a variety of products to use with your DAQCard E Series card, including cables, connector blocks, and other accessories, as follows:

- Cables and cable assemblies, shielded and ribbon
- Connector blocks, shielded and unshielded, with 50- and 68-pin screw terminals
- SCXI modules and accessories for isolating, amplifying, exciting, and multiplexing signals for relays and analog output. With SCXI you can condition and acquire up to 3072 channels.
- Low channel-count signal conditioning modules, cards, and accessories, including conditioning for strain gauges and RTDs, simultaneous sample-and-hold circuitry, and relays

For more specific information about these products, refer to your National Instruments catalogue or call the office nearest you.

Custom Cabling

National Instruments offers cables and accessories for you to prototype your application or to use if you frequently change DAQCard interconnections.

If you want to develop your own cable, however, the following guidelines may be useful:

- For the analog input signals, shielded twisted-pair wires for each analog input pair yield the best results, assuming that you use differential inputs. Tie the shield for each signal pair to the ground reference at the source.
- You should route the analog lines separately from the digital lines.
- When using a cable shield, use separate shields for the analog and digital halves of the cable. Failure to do so results in noise coupling into the analog signals from transient digital signals.

The following list gives recommended National Instruments cable assemblies that mate to your DAQCard I/O connector.

- ◆ DAQCard-AI-16E-4
 - PSHR68-68M, a shielded 68-position ribbon cable, with male-to-male connectors. This connects to an SH6868 or SH6850 shielded cable.
 - PR68-68F, an unshielded 68-position ribbon cable
- ◆ DAQCard-AI-16XE-50
 - PSHR68-68M, a shielded 68-position ribbon cable, with male-to-male connectors. This connects to an SH6868 or SH6850 shielded cable.
 - PR68-68F, an unshielded 68-position ribbon cable

Unpacking

Your DAQCard E Series card is shipped in an antistatic vinyl box. When you are not using your DAQCard, store it in this box. Because your DAQCard is enclosed in a fully shielded case, no additional electrostatic precautions are necessary. However, for your own safety and to protect your DAQCard, never attempt to touch the connector pins.

Installation and Configuration

This chapter explains how to install and configure a DAQCard E Series card.

Installation

**Note**

You should install your driver software before installing your hardware. Refer to your NI-DAQ release notes for software installation instructions.

There is one basic step to installing a DAQCard E Series card.

1. Insert the DAQCard and attach the I/O cable.

The DAQCard has two connectors—a 68-pin PCMCIA bus connector on one end and a 68-pin I/O connector on the other end. Insert the PCMCIA bus connector into any available Type II PCMCIA slot until the connector is seated firmly. Notice that the DAQCard and I/O cable are both keyed so that the cable can be inserted only one way.

Be careful not to put strain on the I/O cable when inserting it into and removing it from the DAQCard. Always grasp the cable by the connector you are plugging or unplugging. *Never* pull directly on the I/O cable to unplug it from the DAQCard.

Your DAQCard can be connected to 68- and 50-pin accessories. You can use either a 68-pin female cable to plug into the PSHR68-68M with your DAQCard, or a 50-pin male cable and the PSHR68-68M and SH6850 with your DAQCard. See Appendix B, [Optional Cable Connector Descriptions](#), for more information.

The DAQCard is now installed. You are ready to make the appropriate connections to the I/O connector cable as described in Chapter 4, [Signal Connections](#).

Figure 2-1 shows an example of a typical configuration.

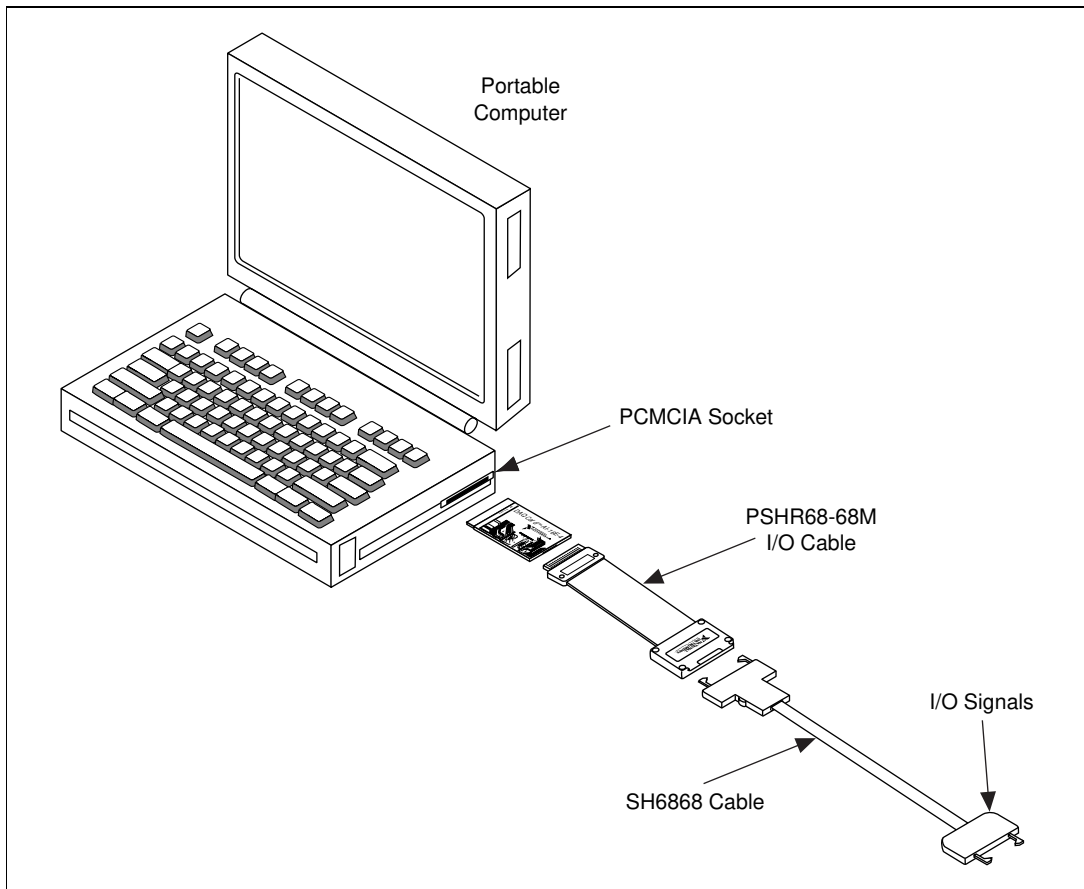

Figure 2-1. A Typical Configuration for the DAQCard E Series Card

Configuration

Your DAQCard is completely software-configurable. Refer to the NI-DAQ Configuration Utility online help file to configure your DAQCard.

If you are using NI-DAQ, refer to your NI-DAQ release notes to install your driver software. Find the installation section for your operating system and follow the instructions given there.

If you are using LabVIEW, refer to your LabVIEW release notes to install your application software. After you have installed LabVIEW, refer to the NI-DAQ release notes and follow the instructions given there for your operating system and LabVIEW.

If you are using LabWindows/CVI, refer to your LabWindows/CVI release notes to install your application software. After you have installed LabWindows/CVI, refer to the NI-DAQ release notes and follow the instructions given there for your operating system and LabWindows/CVI.

Hardware Overview

This chapter presents an overview of the hardware functions on your DAQCard E Series card.

Figure 3-1 shows the block diagram for the DAQCard-AI-16E-4.

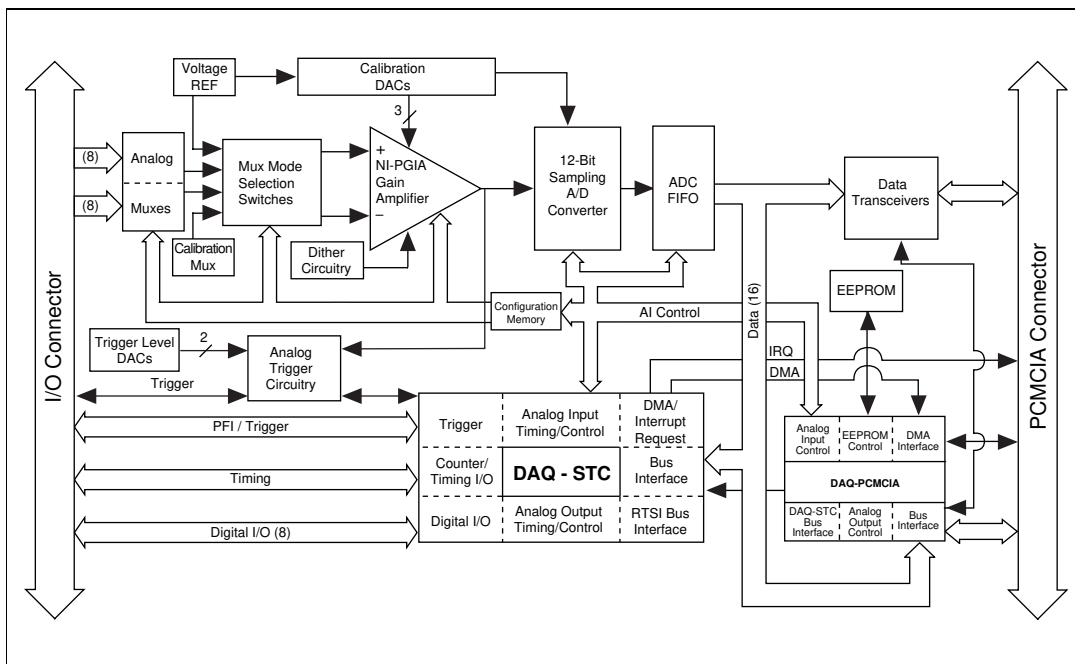

Figure 3-1. DAQCard-AI-16E-4 Block Diagram

Figure 3-2 shows a block diagram for the DAQCard-AI-16XE-50.

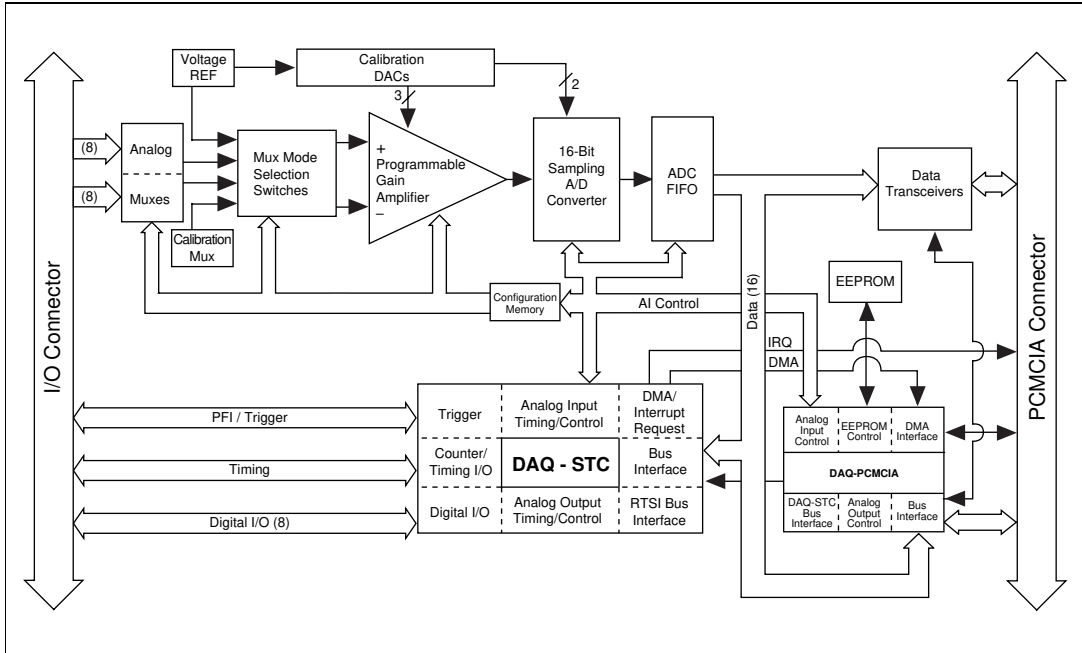

Figure 3-2. DAQCard-AI-16XE-50 Block Diagram

Analog Input

The analog input section of each DAQCard is software configurable. You can select different analog input configurations through application software designed to control the DAQCards. The following sections describe in detail each of the analog input categories.

Input Mode

The DAQCards have three different input modes—nonreferenced single-ended (NRSE) input, referenced single-ended (RSE) input, and differential (DIFF) input. The single-ended input configurations use up to 16 channels. The DIFF input configuration uses up to eight channels. Input modes are programmed on a per channel basis for multimode scanning. For example, you can configure the circuitry to scan 12 channels—four differentially configured channels and eight single-ended channels. Table 3-1 describes the three input configurations.

Table 3-1. Available Input Configurations for the DAQCard E Series

Configuration	Description
DIFF	A channel configured in DIFF mode uses two analog channel input lines. One line connects to the positive input of the DAQCard programmable gain instrumentation amplifier (PGIA), and the other connects to the negative input of the PGIA.
RSE	A channel configured in RSE mode uses one analog channel input line, which connects to the positive input of the PGIA. The negative input of the PGIA is internally tied to analog input ground (AIGND).
NRSE	A channel configured in NRSE mode uses one analog channel input line, which connects to the positive input of the PGIA. The negative input of the PGIA connects to the analog input sense (AISENSE) input.

For more information about the three types of input configuration, refer to the *Analog Input Signal Connections* section in Chapter 4, *Signal Connections*, which contains diagrams showing the signal paths for the three configurations.

Input Polarity and Input Range

◆ DAQCard-AI-16E-4

This DAQCard has two input polarities—unipolar and bipolar. Unipolar input means that the input voltage range is between 0 and V_{ref} , where V_{ref} is a positive reference voltage. Bipolar input means that the input voltage range is between $-V_{\text{ref}}/2$ and $+V_{\text{ref}}/2$. The DAQCard-AI-16E-4 has a unipolar input range of 10 V (0 to 10 V) and a bipolar input range of 10 V (± 5 V). You can program polarity and range settings on a per channel basis so that you can configure each input channel uniquely.

The software-programmable gain on these cards increases their overall flexibility by matching the input signal ranges to those that the ADC can accommodate. The DAQCard-AI-16E-4 has gains of 0.5, 1, 2, 5, 10, 20, 50, and 100 and is suited for a wide variety of signal levels. With the proper gain setting, you can use the ADC's full resolution to measure the input signal. Table 3-2 shows the overall input range and precision according to the range configuration and gain used.

Table 3-2. Actual Range and Measurement Precision

Range Configuration	Gain	Actual Input Range	Resolution ¹
0 to +10 V	1.0	0 to +10 V	2.44 mV
	2.0	0 to +5 V	1.22 mV
	5.0	0 to +2 V	488.28 μ V
	10.0	0 to +1 V	244.14 μ V
	20.0	0 to +500 mV	122.07 μ V
	50.0	0 to +200 mV	48.83 μ V
	100.0	0 to +100 mV	24.41 μ V
-5 to +5 V	0.5	-10 to +10 V	4.88 mV
	1.0	-5 to +5 V	2.44 mV
	2.0	-2.5 to +2.5 V	1.22 mV
	5.0	-1 to +1 V	488.28 μ V
	10.0	-500 to +500 mV	244.14 μ V
	20.0	-250 to +250 mV	122.07 μ V
	50.0	-100 to +100 mV	48.83 μ V
100.0	-50 to +50 mV	24.41 μ V	

¹ The value of 1 LSB of the 12-bit ADC; that is, the voltage increment corresponding to a change of one count in the ADC 12-bit count.

Note: See Appendix A, *Specifications*, for absolute maximum ratings.

◆ DAQCard-AI-16XE-50

This DAQCard has two input polarities—unipolar and bipolar. Unipolar input means that the input voltage range is between 0 and V_{ref} , where V_{ref} is a positive reference voltage. Bipolar input means that the input voltage range is between $-V_{\text{ref}}$ and $+V_{\text{ref}}$. The DAQCard-AI-16XE-50 has a unipolar input range of 10 V (0 to 10 V) and a bipolar input range of 20 V (± 10 V). You can program polarity and range settings on a per channel basis so that you can configure each input channel uniquely.

**Note**

You can calibrate your DAQCard-AI-16XE-50 analog input circuitry for either a unipolar or bipolar polarity. If you mix unipolar and bipolar channels in your scan list and you are using NI-DAQ, then NI-DAQ will load the calibration constants appropriate to the polarity for which analog input channel 0 is configured.

The software-programmable gain on these cards increases their overall flexibility by matching the input signal ranges to those that the ADC can accommodate. The DAQCard-AI-16XE-50 has gains of 1, 2, 10, and 100 and is suited for a wide variety of signal levels. With the proper gain setting, you can use the ADC's full resolution to measure the input signal. Table 3-3 shows the overall input range and precision according to the range configuration and gain used.

Table 3-3. Actual Range and Measurement Precision, DAQCard-AI-16XE-50

Range Configuration	Gain	Actual Input Range	Precision ¹
0 to +10 V	1.0	0 to +10 V	152.59 μ V
	2.0	0 to +5 V	76.29 μ V
	10.0	0 to +1 V	15.26 μ V
	100.0	0 to 100 mV	1.53 μ V
-10 to +10 V	1.0	-10 to +10 V	305.18 μ V
	2.0	-5 to +5 V	152.59 μ V
	10.0	-1 to +1 V	30.52 μ V
	100.0	-100 to +100 mV	3.05 μ V
¹ The value of 1 LSB of the 16-bit ADC; that is, the voltage increment corresponding to a change of one count in the ADC 16-bit count. Note: See Appendix A, <i>Specifications</i> , for absolute maximum ratings.			

Considerations for Selecting Input Ranges

Which input polarity and range you select depends on the expected range of the incoming signal. A large input range can accommodate a large signal variation but reduces the voltage resolution. Choosing a smaller input range improves the voltage resolution but may result in the input signal going out of range. For best results, you should match the input range as closely as possible to the expected range of the input signal. For example, if you are certain the input signal will not be negative (below 0 V), unipolar input polarity is best. However, if the signal is negative or equal to zero, inaccurate readings will occur if you use unipolar input polarity.

Dither

When you enable dither, you add approximately 0.5 LSB rms of white Gaussian noise to the signal to be converted by the ADC. This addition is useful for applications involving averaging to increase the resolution of your DAQCard, as in calibration or spectral analysis. In such applications, noise modulation is decreased and differential linearity is improved by the addition of dither. When taking DC measurements, such as when checking the DAQCard calibration, you should enable dither and average about 1,000 points to take a single reading. This process removes the effects of quantization and reduces measurement noise, resulting in improved resolution. For high-speed applications not involving averaging or spectral analysis, you may want to disable the dither to reduce noise. You enable and disable the dither circuitry through software.

Figure 3-3 illustrates the effect of dither on signal acquisition. Figure 3-3a shows a small (± 4 LSB) sine wave acquired with dither off. The quantization of the ADC is clearly visible. Figure 3-3b shows what happens when 50 such acquisitions are averaged together; quantization is still plainly visible. In Figure 3-3c, the sine wave is acquired with dither on. There is a considerable amount of noise visible. But averaging about 50 such acquisitions, as shown in Figure 3-3d, eliminates both the added noise and the effects of quantization. Dither has the effect of forcing quantization noise to become a zero-mean random variable rather than a deterministic function of the input signal.

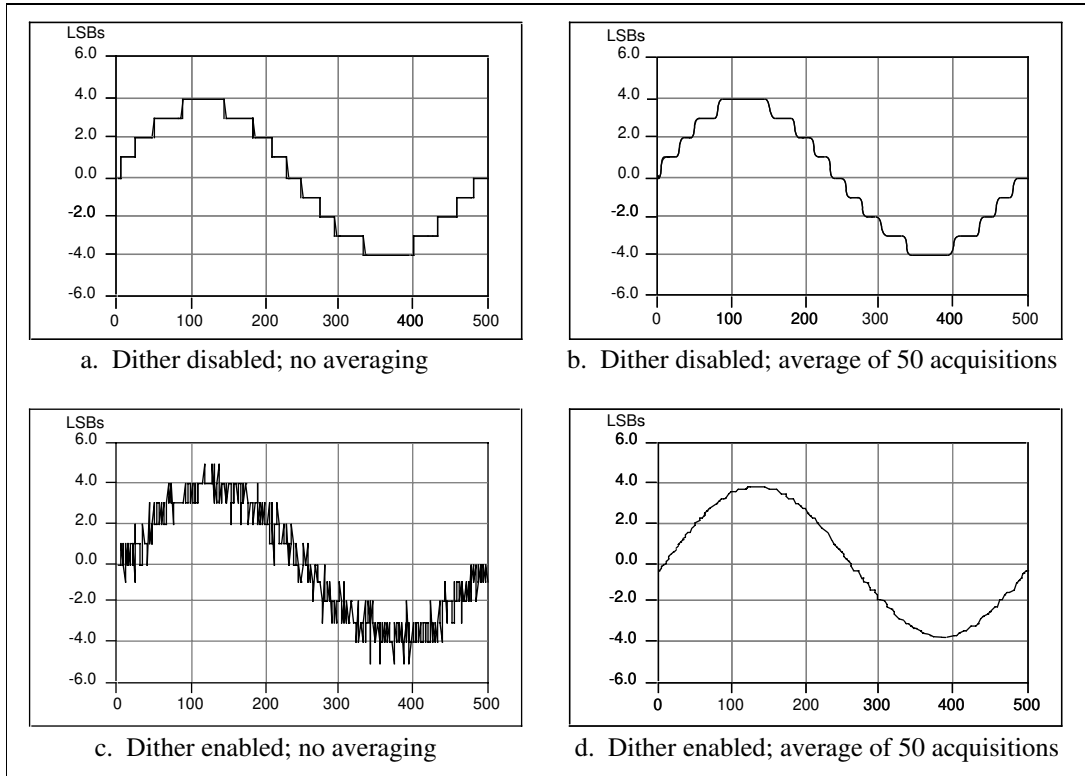

Figure 3-3. Dither

You cannot disable dither on the DAQCard-AI-16XE-50. This is because the ADC resolution is so fine that the ADC and the PGIA inherently produce more than 0.5 LSB rms of noise. This is equivalent to having a dither circuit that is always enabled.

Multichannel Scanning Considerations

All of the DAQCard E Series cards can scan multiple channels at the same maximum rate as their single-channel rate; however, pay careful attention to the settling times for each of the DAQCards. The settling time for most of the DAQCards is independent of the selected gain, even at the maximum sampling rate. The settling time for the high channel count and very high-speed cards is gain dependent, which can affect the useful sampling rate for a given gain. No extra settling time is necessary between channels as long as the gain is constant and source impedances are low. Refer to Appendix A, *Specifications*, for a complete listing of settling times for each of the DAQCards.

When scanning among channels at various gains, the settling times may increase. When the PGIA switches to a higher gain, the signal on the previous channel may be well outside the new, smaller range. For instance, suppose a 4 V signal is connected to channel 0 and a 1 mV signal is connected to channel 1, and suppose the PGIA is programmed to apply a gain of one to channel 0 and a gain of 100 to channel 1. When the multiplexer switches to channel 1 and the PGIA switches to a gain of 100, the new full-scale range is 100 mV (if the ADC is in unipolar mode).

The approximately 4 V step from 4 V to 1 mV is 4,000% of the new full-scale range. For a 12-bit DAQCard to settle within 0.012% (120 ppm or 1/2 LSB) of the 100 mV full-scale range on channel 1, the input circuitry has to settle to within 0.0003% (3 ppm or 1/80 LSB) of the 4 V step. It may take as long as 100 μ s for the circuitry to settle this much. For a 16-bit DAQCard to settle within 0.0015% (15 ppm or 1 LSB) of the 100 mV full-scale range on channel 1, the input circuitry has to settle within 0.00004% (0.4 ppm or 1/400 LSB) of the 4 V step. It may take as long as 200 μ s for the circuitry to settle this much. In general, this extra settling time is not needed when the PGIA is switching to a lower gain.

Settling times can also increase when scanning high-impedance signals due to a phenomenon called *charge injection*, where the analog input multiplexer injects a small amount of charge into each signal source when that source is selected. If the source impedance is not low enough, the effect of the charge—a voltage error—will not have decayed by the time the ADC samples the signal. For this reason, you should keep source impedances under 1 k Ω to perform high-speed scanning.

Due to the previously described limitations of settling times resulting from these conditions, multichannel scanning is not recommended unless sampling rates are low enough or it is necessary to sample several signals as nearly simultaneously as possible. The data is much more accurate and channel-to-channel independent if you acquire data from each channel independently (for example, 100 points from channel 0, then 100 points from channel 1, then 100 points from channel 2, and so on).

Analog Trigger

◆ DAQCard-AI-16E-4

In addition to supporting internal software triggering and external digital triggering to initiate a data acquisition sequence, the DAQCard-AI-16E-4 also supports analog triggering. You can configure the analog trigger circuitry to accept either a direct analog input from the PFI0/TRIG1 pin on the I/O connector or a postgain signal from the output of the PGIA, as shown in Figure 3-4. The trigger-level range for the direct analog channel is ± 10 V in 78 mV steps. The range for the post-PGIA trigger selection is simply the full-scale range of the selected channel, and the resolution is that range divided by 256.

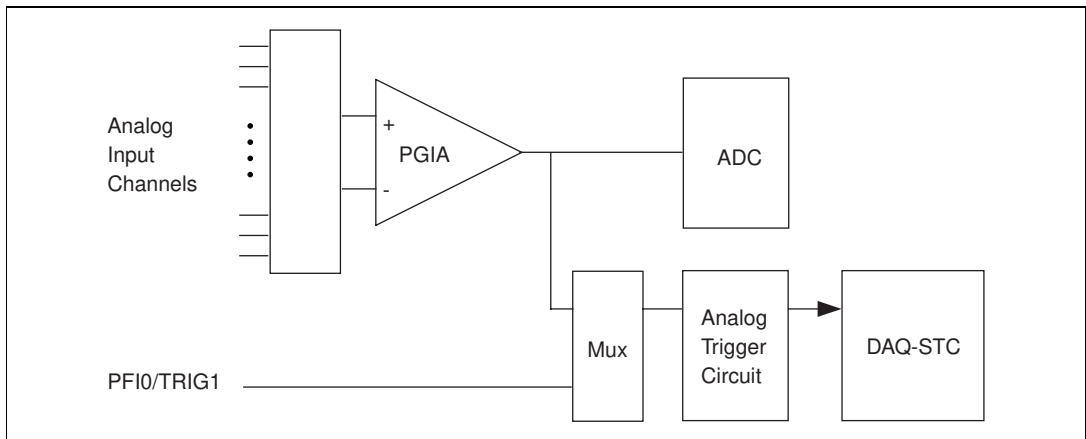

Figure 3-4. Analog Trigger Block Diagram

There are five analog triggering modes available, as shown in Figures 3-5 through 3-9. You can set **lowValue** and **highValue** independently in software.

In below-low-level analog triggering mode, the trigger is generated when the signal value is less than **lowValue**. **HighValue** is unused.

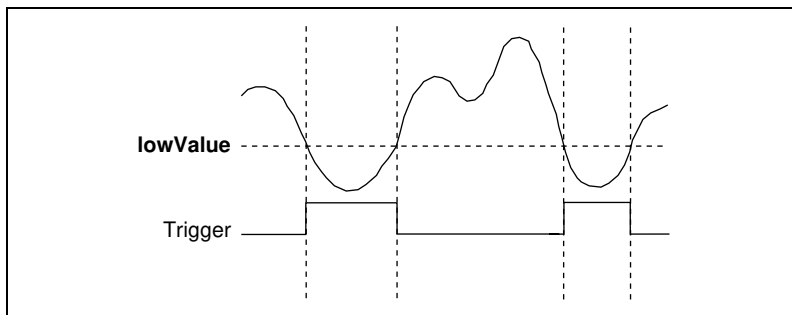

Figure 3-5. Below-Low-Level Analog Triggering Mode

In above-high-level analog triggering mode, the trigger is generated when the signal value is greater than **highValue**. **LowValue** is unused.

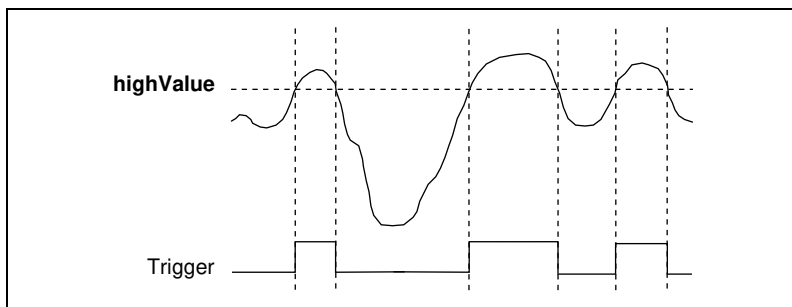

Figure 3-6. Above-High-Level Analog Triggering Mode

In inside-region analog triggering mode, the trigger is generated when the signal value is between the **lowValue** and the **highValue**.

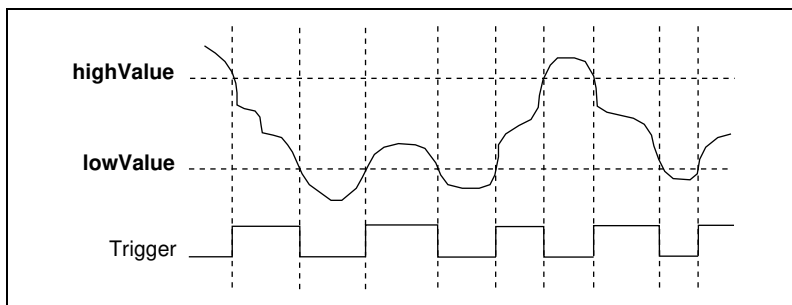

Figure 3-7. Inside-Region Analog Triggering Mode

In high-hysteresis analog triggering mode, the trigger is generated when the signal value is greater than **highValue**, with the hysteresis specified by **lowValue**.

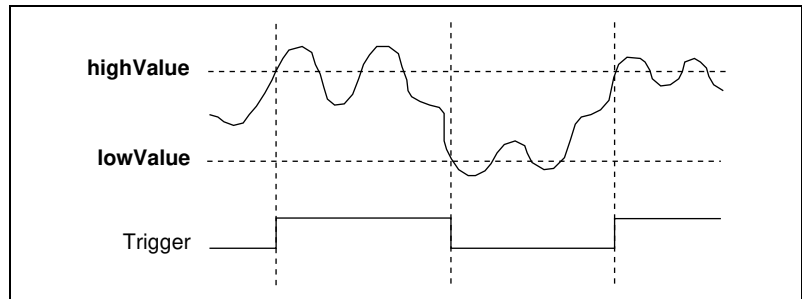

Figure 3-8. High-Hysteresis Analog Triggering Mode

In low-hysteresis analog triggering mode, the trigger is generated when the signal value is less than **lowValue**, with the hysteresis specified by **highValue**.

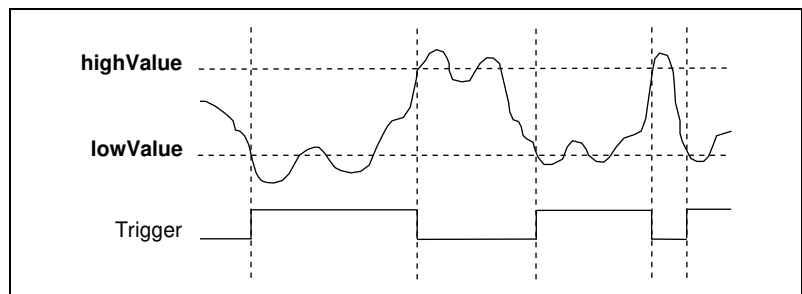

Figure 3-9. Low-Hysteresis Analog Triggering Mode

The analog trigger circuit generates an internal digital trigger based on the analog input signal and the user-defined trigger levels. This digital trigger can be used by any of the timing sections of the DAQ-STC, including the analog input, analog output, and general-purpose counter/timer sections. For example, the analog input section can be configured to acquire n scans after the analog input signal crosses a specific threshold. As another example, the analog output section can be configured to update its outputs whenever the analog input signal crosses a specific threshold.

Digital I/O

The DAQCard E Series cards contain eight lines of digital I/O for general-purpose use. You can individually configure each line through software for either input or output. At system startup and reset, the digital I/O ports are all high impedance.

The hardware up/down control for general-purpose counters 0 and 1 are connected onboard to DIO6 and DIO7, respectively. Thus, you can use DIO6 and DIO7 to control the general-purpose counters. The up/down control signals are input only and do not affect the operation of the DIO lines.

Timing Signal Routing

The DAQ-STC provides a very flexible interface for connecting timing signals to other boards or external circuitry. Your DAQCard uses the Programmable Function Input (PFI) pins on the I/O connector to connect to external circuitry. These connections are designed to enable the DAQCard to both control and be controlled by other boards and circuits.

The DAQ-STC has a total of 13 internal timing signals that can be controlled by an external source. These timing signals can also be controlled by signals generated internally to the DAQ-STC, and these selections are fully software configurable. For example, the signal routing multiplexer for controlling the CONVERT* signal is shown in Figure 3-10.

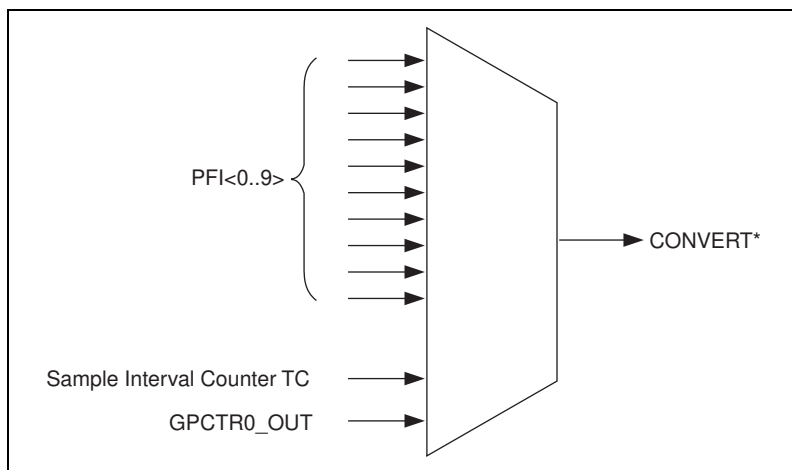

Figure 3-10. CONVERT* Signal Routing

This figure shows that CONVERT* can be generated from a number of sources, including the external signals PFI<0..9> and the internal signals Sample Interval Counter TC and GPCTRO_OUT.

Programmable Function Inputs

The 10 PFIs are connected to the signal routing multiplexer for each timing signal, and software can select one of the PFIs as the external source for a given timing signal. It is important to note that any of the PFIs can be used as an input by any of the timing signals and that multiple timing signals can use the same PFI simultaneously. This flexible routing scheme reduces the need to change physical connections to the I/O connector for different applications.

You can also individually enable each of the PFI pins to output a specific internal timing signal. For example, if you need the UPDATE* signal as an output on the I/O connector, software can turn on the output driver for the PFI5/UPDATE* pin.

DAQCard Clocks

Many functions performed by the DAQCard E Series cards require a frequency timebase to generate the necessary timing signals for controlling A/D conversions, DAC updates, or general-purpose signals at the I/O connector.

A DAQCard can directly use its internal 20 MHz timebase as the primary frequency source.

Signal Connections

This chapter describes how to make input and output signal connections to your DAQCard E Series card via the DAQCard I/O connector.

The I/O connector for the DAQCard E Series cards has 68 pins that you can connect to 68-pin accessories with the PSHR68-68M and SH6868 shielded cables, or the PR68-68F ribbon cable. With the PSHR68-68M and SH6868 shielded cables or the PR68-50F ribbon cable, you can connect your DAQCard to 50-pin signal conditioning modules and terminal blocks.

I/O Connector

Figure 4-1 shows the pin assignments for the 68-pin I/O connector on the DAQCard-AI-16E-4 and DAQCard-AI-16XE-50. A signal description follows the connector pinouts.



Warning *Exceeding the differential and common-mode input ranges distorts your input signals. Exceeding the maximum input voltage rating can damage the DAQCard E Series card and your computer. National Instruments is NOT liable for any damages resulting from such signal connections. The maximum input voltage ratings are listed in Tables 4-1 through 4-3 in the Protection column.*

ACH8	34	68	ACH0
ACH1	33	67	AIGND
AIGND	32	66	ACH9
ACH10	31	65	ACH2
ACH3	30	64	AIGND
AIGND	29	63	ACH11
ACH4	28	62	AISENSE
AIGND	27	61	ACH12
ACH13	26	60	ACH5
ACH6	25	59	AIGND
AIGND	24	58	ACH14
ACH15	23	57	ACH7
Reserved	22	56	AIGND
Reserved	21	55	Reserved
Reserved	20	54	Reserved
DIO4	19	53	DGND
DGND	18	52	DIO0
DIO1	17	51	DIO5
DIO6	16	50	DGND
DGND	15	49	DIO2
+5 V	14	48	DIO7
DGND	13	47	DIO3
DGND	12	46	SCANCLK
PFI0/TRIG1	11	45	EXTSTROBE*
PFI1/TRIG2	10	44	DGND
DGND	9	43	PFI2/CONVERT*
+5 V	8	42	PFI3/GPCTR1_SOURCE
DGND	7	41	PFI4/GPCTR1_GATE
PFI5/UPDATE*	6	40	GPCTR1_OUT
PFI6/WFTRIG	5	39	DGND
DGND	4	38	PFI7/STARTSCAN
PFI9/GPCTR0_GATE	3	37	PFI8/GPCTR0_SOURCE
GPCTR0_OUT	2	36	DGND
FREQ_OUT	1	35	DGND

Figure 4-1. I/O Connector Pin Assignment for the DAQCard-AI-16E-4 and DAQCard-AI-16XE-50

Table 4-1. I/O Connector Signal Descriptions

Signal Name	Reference	Direction	Description
AIGND	—	—	Analog Input Ground—These pins are the reference point for single-ended measurements and the bias current return point for differential measurements. All three ground references—AIGND, AOGND, and DGND—are connected together on your DAQCard E Series card.
ACH<0..15>	AIGND	Input	Analog Input Channels 0 through 15—Each channel pair, ACH< <i>i</i> , <i>i</i> +8> (<i>i</i> = 0..7), can be configured as either one differential input or two single-ended inputs.
AISENSE	AIGND	Input	Analog Input Sense—This pin serves as the reference node for any of channels ACH<0..15> in NRSE configuration.
DGND	—	—	Digital Ground—This pin supplies the reference for the digital signals at the I/O connector as well as the +5 VDC supply. All three ground references—AIGND, AOGND, and DGND—are connected together on your DAQCard.
DIO<0..7>	DGND	Input or Output	Digital I/O signals—DIO6 and 7 can control the up/down signal of general-purpose counters 0 and 1, respectively.
+5 V	DGND	Output	+5 VDC Source—These pins are fused for up to 250 mA of +5 V supply. The fuse is self-resetting.
SCANCLK	DGND	Output	Scan Clock—This pin pulses once for each A/D conversion in the scanning modes when enabled. The low-to-high edge indicates when the input signal can be removed from the input or switched to another signal.
EXTSTROBE*	DGND	Output	External Strobe—This output can be toggled under software control to latch signals or trigger events on external devices.
PFI0/TRIG1	DGND	Input Output	PFI0/Trigger 1—As an input, this is either one of the PFIs or the source for the hardware analog trigger. PFI signals are explained in the Timing Connections section later in this chapter. The hardware analog trigger is explained in the Analog Trigger section in Chapter 3, Hardware Overview . As an output, this is the TRIG1 signal. In posttrigger data acquisition sequences, a low-to-high transition indicates the initiation of the acquisition sequence. In pretrigger applications, a low-to-high transition indicates the initiation of the pretrigger conversions.
PFI1/TRIG2	DGND	Input Output	PFI1/Trigger 2—As an input, this is one of the PFIs. As an output, this is the TRIG2 signal. In pretrigger applications, a low-to-high transition indicates the initiation of the posttrigger conversions. TRIG2 is not used in posttrigger applications.

Table 4-1. I/O Connector Signal Descriptions (Continued)

Signal Name	Reference	Direction	Description
PFI2/CONVERT*	DGND	Input Output	PFI2/Convert—As an input, this is one of the PFIs. As an output, this is the CONVERT* signal. A high-to-low edge on CONVERT* indicates that an A/D conversion is occurring.
PFI3/GPCTR1_SOURCE	DGND	Input Output	PFI3/Counter 1 Source—As an input, this is one of the PFIs. As an output, this is the GPCTR1_SOURCE signal. This signal reflects the actual source connected to general-purpose counter 1.
PFI4/GPCTR1_GATE	DGND	Input Output	PFI4/Counter 1 Gate—As an input, this is one of the PFIs. As an output, this is the GPCTR1_GATE signal. This signal reflects the actual gate signal connected to general-purpose counter 1.
GPCTR1_OUT	DGND	Output	Counter 1 Output—This output is from the general-purpose counter 1 output.
PFI5/UPDATE*	DGND	Input Output	PFI5/Update—As an input, this is one of the PFIs. As an output, this is the UPDATE* signal. A high-to-low edge on UPDATE* indicates that the analog output primary group is being updated.
PFI6/WFTRIG	DGND	Input Output	PFI6/Waveform Trigger—As an input, this is one of the PFIs. As an output, this is the WFTRIG signal. In timed analog output sequences, a low-to-high transition indicates the initiation of the waveform generation.
PFI7/STARTSCAN	DGND	Input Output	PFI7/Start of Scan—As an input, this is one of the PFIs. As an output, this is the STARTSCAN signal. This pin pulses once at the start of each analog input scan in the interval scan. A low-to-high transition indicates the start of the scan.
PFI8/GPCTR0_SOURCE	DGND	Input Output	PFI8/Counter 0 Source—As an input, this is one of the PFIs. As an output, this is the GPCTR0_SOURCE signal. This signal reflects the actual source connected to general-purpose counter 0.

Table 4-1. I/O Connector Signal Descriptions (Continued)

Signal Name	Reference	Direction	Description
PFI9/GPCTR0_GATE	DGND	Input Output	PFI9/Counter 0 Gate—As an input, this is one of the PFIs. As an output, this is the GPCTR0_GATE signal. This signal reflects the actual gate signal connected to general-purpose counter 0.
GPCTR0_OUT	DGND	Output	Counter 0 Output—This output is from the general-purpose counter 0 output.
FREQ_OUT	DGND	Output	Frequency Output—This output is from the frequency generator output.

Table 4-2 shows the I/O signal summary for the DAQCard-AI-16E-4.

Table 4-2. I/O Signal Summary, DAQCard-AI-16E-4

Signal Name	Drive	Impedance Input/ Output	Protection (Volts) On/Off	Source (mA at V)	Sink (mA at V)	Rise Time (ns)	Bias
ACH<0..15>	AI	100 G Ω in parallel with 100 pF	25/10	—	—	—	± 200 pA
AISENSE	AI	100 G Ω in parallel with 100 pF	25/10	—	—	—	± 200 pA
AIGND	AI	—	—	—	—	—	—
DGND	DO	—	—	—	—	—	—
VCC	DO	0.45 Ω	Short-circuit to ground	250 at V _{cc}	—	—	—
DIO<0..7>	DIO	—	V _{cc} +0.5	13 at (V _{cc} -0.4)	24 at 0.4	1.1	50 k Ω pu ¹
SCANCLK	DO	—	—	3.5 at (V _{cc} -0.4)	5 at 0.4	1.5	50 k Ω pu
EXTSTROBE*	DO	—	—	3.5 at (V _{cc} -0.4)	5 at 0.4	1.5	50 k Ω pu
PFI0/TRIG1	ADIO	10 k Ω	V _{cc} +0.5/ ± 35	3.5 at (V _{cc} -0.4)	5 at 0.4	1.5	50 k Ω pu ²
PFI1/TRIG2	DIO	—	V _{cc} +0.5	3.5 at (V _{cc} -0.4)	5 at 0.4	1.5	50 k Ω pu
PFI2/CONVERT*	DIO	—	V _{cc} +0.5	3.5 at (V _{cc} -0.4)	5 at 0.4	1.5	50 k Ω pu
PFI3/GPCTR1_SOURCE	DIO	—	V _{cc} +0.5	3.5 at (V _{cc} -0.4)	5 at 0.4	1.5	50 k Ω pu
PFI4/GPCTR1_GATE	DIO	—	V _{cc} +0.5	3.5 at (V _{cc} -0.4)	5 at 0.4	1.5	50 k Ω pu

Table 4-2. I/O Signal Summary, DAQCard-AI-16E-4 (Continued)

Signal Name	Drive	Impedance Input/Output	Protection (Volts) On/Off	Source (mA at V)	Sink (mA at V)	Rise Time (ns)	Bias
GPCTR1_OUT	DO	—	—	3.5 at ($V_{cc} - 0.4$)	5 at 0.4	1.5	50 k Ω pu
PFI5/UPDATE*	DIO	—	$V_{cc} + 0.5$	3.5 at ($V_{cc} - 0.4$)	5 at 0.4	1.5	50 k Ω pu
PFI6/WFTRIG	DIO	—	$V_{cc} + 0.5$	3.5 at ($V_{cc} - 0.4$)	5 at 0.4	1.5	50 k Ω pu
PFI7/STARTSCAN	DIO	—	$V_{cc} + 0.5$	3.5 at ($V_{cc} - 0.4$)	5 at 0.4	1.5	50 k Ω pu
PFI8/GPCTR0_SOURCE	DIO	—	$V_{cc} + 0.5$	3.5 at ($V_{cc} - 0.4$)	5 at 0.4	1.5	50 k Ω pu
PFI9/GPCTR0_GATE	DIO	—	$V_{cc} + 0.5$	3.5 at ($V_{cc} - 0.4$)	5 at 0.4	1.5	50 k Ω pu
GPCTR0_OUT	DO	—	—	3.5 at ($V_{cc} - 0.4$)	5 at 0.4	1.5	50 k Ω pu
FREQ_OUT	DO	—	—	3.5 at ($V_{cc} - 0.4$)	5 at 0.4	1.5	50 k Ω pu
AI = Analog Input DO = Digital Output DIO = Digital Input/Output ADIO = Analog/Digital Input/Output pu = pullup ¹ DIO <6..7> are also pulled up with a 10 k Ω resistor. ² Also pulled down with a 10 k Ω resistor. Warning: Unless specifically indicated in the Protection column of Table 4-2, the outputs of DAQCard E Series cards are not short-circuit protected. Exceeding the output limit in the Source and Sink columns can damage your DAQCard.							

Table 4-3 shows the I/O signal summary for the DAQCard-AI-16XE-50.

Table 4-3. I/O Signal Summary, DAQCard-AI-16XE-50

Signal Name	Drive	Impedance Input/Output	Protection (Volts) On/Off	Source (mA at V)	Sink (mA at V)	Rise Time (ns)	Bias
ACH<0..15>	AI	20 G Ω in parallel with 100 pF	25/15	—	—	—	± 10 nA
AISENSE	AI	20 G Ω in parallel with 100 pF	25/15	—	—	—	± 10 nA
AIGND	AI	—	—	—	—	—	—
DGND	DO	—	—	—	—	—	—
VCC	DO	0.45 Ω	Short-circuit to ground	250 at V_{cc}	—	—	—

Table 4-3. I/O Signal Summary, DAQCard-AI-16XE-50 (Continued)

Signal Name	Drive	Impedance Input/Output	Protection (Volts) On/Off	Source (mA at V)	Sink (mA at V)	Rise Time (ns)	Bias
DIO<0..7>	DIO	—	$V_{cc} + 0.5$	13 at ($V_{cc} - 0.4$)	24 at 0.4	1.1	50 k Ω pu ¹
SCANCLK	DO	—	—	3.5 at ($V_{cc} - 0.4$)	5 at 0.4	1.5	50 k Ω pu
EXTSTROBE*	DO	—	—	3.5 at ($V_{cc} - 0.4$)	5 at 0.4	1.5	50 k Ω pu
PFI0/TRIG1	DIO	—	$V_{cc} + 0.5$	3.5 at ($V_{cc} - 0.4$)	5 at 0.4	1.5	50 k Ω pu
PFI1/TRIG2	DIO	—	$V_{cc} + 0.5$	3.5 at ($V_{cc} - 0.4$)	5 at 0.4	1.5	50 k Ω pu
PFI2/CONVERT*	DIO	—	$V_{cc} + 0.5$	3.5 at ($V_{cc} - 0.4$)	5 at 0.4	1.5	50 k Ω pu
PFI3/GPCTR1_SOURCE	DIO	—	$V_{cc} + 0.5$	3.5 at ($V_{cc} - 0.4$)	5 at 0.4	1.5	50 k Ω pu
PFI4/GPCTR1_GATE	DIO	—	$V_{cc} + 0.5$	3.5 at ($V_{cc} - 0.4$)	5 at 0.4	1.5	50 k Ω pu
GPCTR1_OUT	DO	—	—	3.5 at ($V_{cc} - 0.4$)	5 at 0.4	1.5	50 k Ω pu
PFI5/UPDATE*	DIO	—	$V_{cc} + 0.5$	3.5 at ($V_{cc} - 0.4$)	5 at 0.4	1.5	50 k Ω pu
PFI6/WFTRIG	DIO	—	$V_{cc} + 0.5$	3.5 at ($V_{cc} - 0.4$)	5 at 0.4	1.5	50 k Ω pu
PFI7/STARTSCAN	DIO	—	$V_{cc} + 0.5$	3.5 at ($V_{cc} - 0.4$)	5 at 0.4	1.5	50 k Ω pu
PFI8/GPCTR0_SOURCE	DIO	—	$V_{cc} + 0.5$	3.5 at ($V_{cc} - 0.4$)	5 at 0.4	1.5	50 k Ω pu
PFI9/GPCTR0_GATE	DIO	—	$V_{cc} + 0.5$	3.5 at ($V_{cc} - 0.4$)	5 at 0.4	1.5	50 k Ω pu
GPCTR0_OUT	DO	—	—	3.5 at ($V_{cc} - 0.4$)	5 at 0.4	1.5	50 k Ω pu
FREQ_OUT	DO	—	—	3.5 at ($V_{cc} - 0.4$)	5 at 0.4	1.5	50 k Ω pu
AI = Analog Input DIO = Digital Input/Output pu = pullup DO = Digital Output							
¹ DIO <6..7> are also pulled up with a 10 k Ω resistor.							
Warning: Unless specifically indicated in the Protection column of Table 4-3, the outputs of DAQCard E Series cards are not short-circuit protected. Exceeding the output limit in the Source and Sink columns can damage your DAQCard.							

Analog Input Signal Connections

The analog input signals are ACH<0..15>, AISENSE, and AIGND. The ACH<0..15> signals are tied to the 16 analog input channels of your DAQCard. In single-ended mode, signals connected to ACH<0..15> are routed to the positive input of the DAQCard PGIA. In differential mode, signals connected to ACH<0..7> are routed to the positive input of the PGIA, and signals connected to ACH<8..15> are routed to the negative input of the PGIA.



Warning *Exceeding the differential and common-mode input ranges distorts your input signals¹. Exceeding the maximum input voltage rating can damage the DAQCard and your computer. National Instruments is NOT liable for any damages resulting from such signal connections. The maximum input voltage ratings are listed in Tables 4-2 through 4-3 in the Protection column.*

In NRSE mode, the AISENSE signal is connected internally to the negative input of the DAQCard PGIA when their corresponding channels are selected. In DIFF and RSE modes, this signal is left unconnected.

AIGND is an analog input common signal that is routed directly to the ground tie point on the DAQCards. You can use this signal for a general analog ground tie point to your DAQCard, if necessary.

Connection of analog input signals to your DAQCard depends on the configuration of the analog input channels you are using and the type of input signal source. With the different configurations, you can use the PGIA in different ways. Figure 4-2 shows a diagram of your DAQCard PGIA.

¹ Note that exceeding input ranges on any channel can affect the measurements on a different channel even if the other channel is well within the input range.

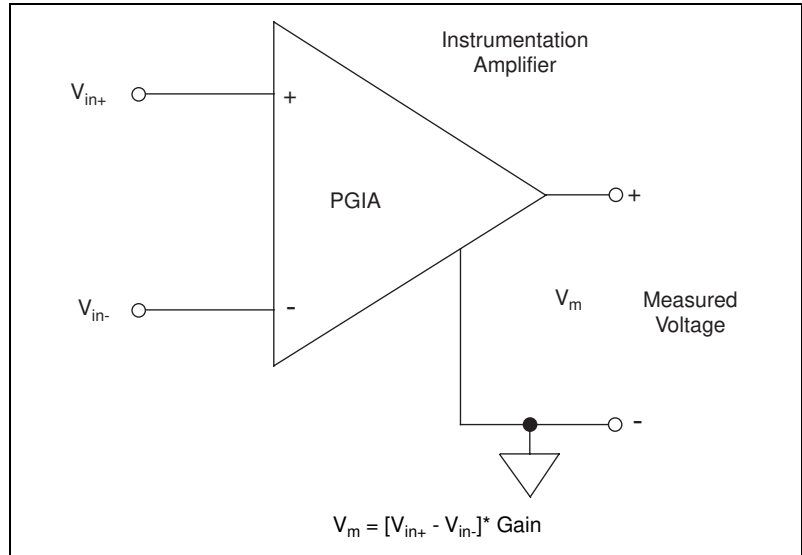

Figure 4-2. DAQCard E Series PGIA

The PGIA applies gain and common-mode voltage rejection and presents high input impedance to the analog input signals connected to your DAQCard. Signals are routed to the positive and negative inputs of the PGIA through input multiplexers on the DAQCard. The PGIA converts two input signals to a signal that is the difference between the two input signals multiplied by the gain setting of the amplifier. The amplifier output voltage is referenced to the ground for the DAQCard. Your DAQCard ADC measures this output voltage when it performs A/D conversions.

You must reference all signals to ground either at the source device or at the DAQCard. If you have a floating source, you should reference the signal to ground by using the RSE input mode or the DIFF input configuration with bias resistors (see the *Differential Connections for Nonreferenced or Floating Signal Sources* later in this chapter). If you have a grounded source, you should not reference the signal to AIGND. You can avoid this reference by using DIFF or NRSE input configurations.

Types of Signal Sources

When configuring the input channels and making signal connections, you must first determine whether the signal sources are floating or ground-referenced. The following sections describe these two types of signals.

Floating Signal Sources

A floating signal source is one that is not connected in any way to the building ground system but, rather, has an isolated ground-reference point. Some examples of floating signal sources are outputs of transformers, thermocouples, battery-powered devices, optical isolator output, and isolation amplifiers. An instrument or device that has an isolated output is a floating signal source. You must tie the ground reference of a floating signal to your DAQCard analog input ground to establish a local or onboard reference for the signal. Otherwise, the measured input signal varies as the source floats out of the common-mode input range.

Ground-Referenced Signal Sources

A ground-referenced signal source is one that is connected in some way to the building system ground and is, therefore, already connected to a common ground point with respect to the DAQCard, assuming that the computer is plugged into the same power system. Nonisolated output of instruments and devices that plug into the building power system falls into this category.

The difference in ground potential between two instruments connected to the same building power system is typically between 1 and 100 mV but can be much higher if power distribution circuits are not properly connected. If a grounded signal source is improperly measured, this difference may appear as an error in the measurement. The connection instructions for grounded signal sources are designed to eliminate this ground potential difference from the measured signal.

Input Configurations

You can configure your DAQCard for one of three input modes—NRSE, RSE, or DIFF. The following sections discuss the use of single-ended and differential measurements and considerations for measuring both floating and ground-referenced signal sources.

Figure 4-3 summarizes the recommended input configuration for both types of signal sources.

Input	Signal Source Type	
	Floating Signal Source (Not Connected to Building Ground)	Grounded Signal Source
	<p>Examples</p> <ul style="list-style-type: none"> • Ungrounded Thermocouples • Signal conditioning with isolated outputs • Battery devices 	<p>Examples</p> <ul style="list-style-type: none"> • Plug-in instruments with nonisolated outputs
Differential (DIFF)	 <p>See text for information on bias resistors.</p>	
Single-Ended — Ground Referenced (RSE)		<p>NOT RECOMMENDED</p>  <p>Ground-loop losses, V_g, are added to measured signal</p>
Single-Ended — Nonreferenced (NRSE)	 <p>See text for information on bias resistors.</p>	

Figure 4-3. Summary of Analog Input Connections

Differential Connection Considerations (DIFF Input Configuration)

A differential connection is one in which the DAQCard analog input signal has its own reference signal or signal return path. These connections are available when the selected channel is configured in DIFF input mode. The input signal is tied to the positive input of the PGIA, and its reference signal, or return, is tied to the negative input of the PGIA.

When you configure a channel for differential input, each signal uses two multiplexer inputs—one for the signal and one for its reference signal. Therefore, with a differential configuration for every channel, up to eight analog input channels are available.

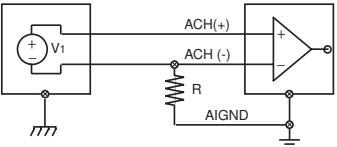
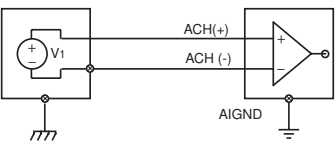
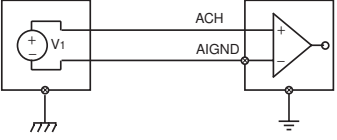
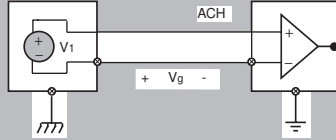
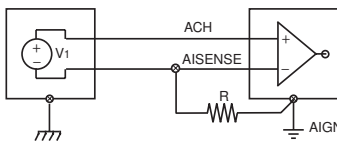
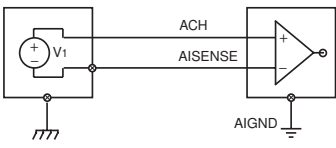
You should use differential input connections for any channel that meets any of the following conditions:

- The input signal is low level (less than 1 V).
- The leads connecting the signal to the DAQCard are greater than 10 ft (3 m).
- The input signal requires a separate ground-reference point or return signal.
- The signal leads travel through noisy environments.

Differential signal connections reduce picked-up noise and increase common-mode noise rejection. Differential signal connections also allow input signals to float within the common-mode limits of the PGIA.

Differential Connections for Ground-Referenced Signal Sources

Figure 4-4 shows how to connect a ground-referenced signal source to a channel on a DAQCard configured in DIFF input mode.

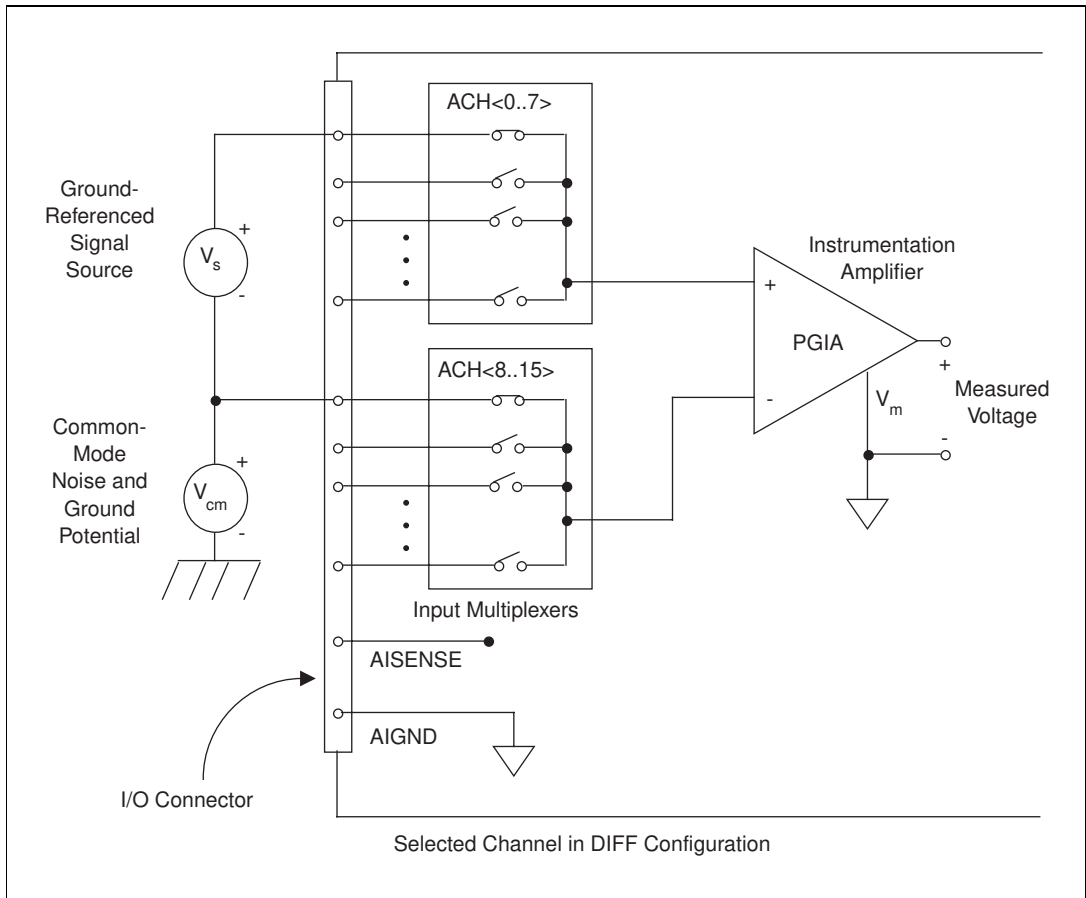

Figure 4-4. Differential Input Connections for Ground-Referenced Signals

With this type of connection, the PGIA rejects both the common-mode noise in the signal and the ground potential difference between the signal source and the DAQCard ground, shown as V_{cm} in Figure 4-4.

Differential Connections for Nonreferenced or Floating Signal Sources

Figure 4-5 shows how to connect a floating signal source to a channel on a DAQCard configured in DIFF input mode.

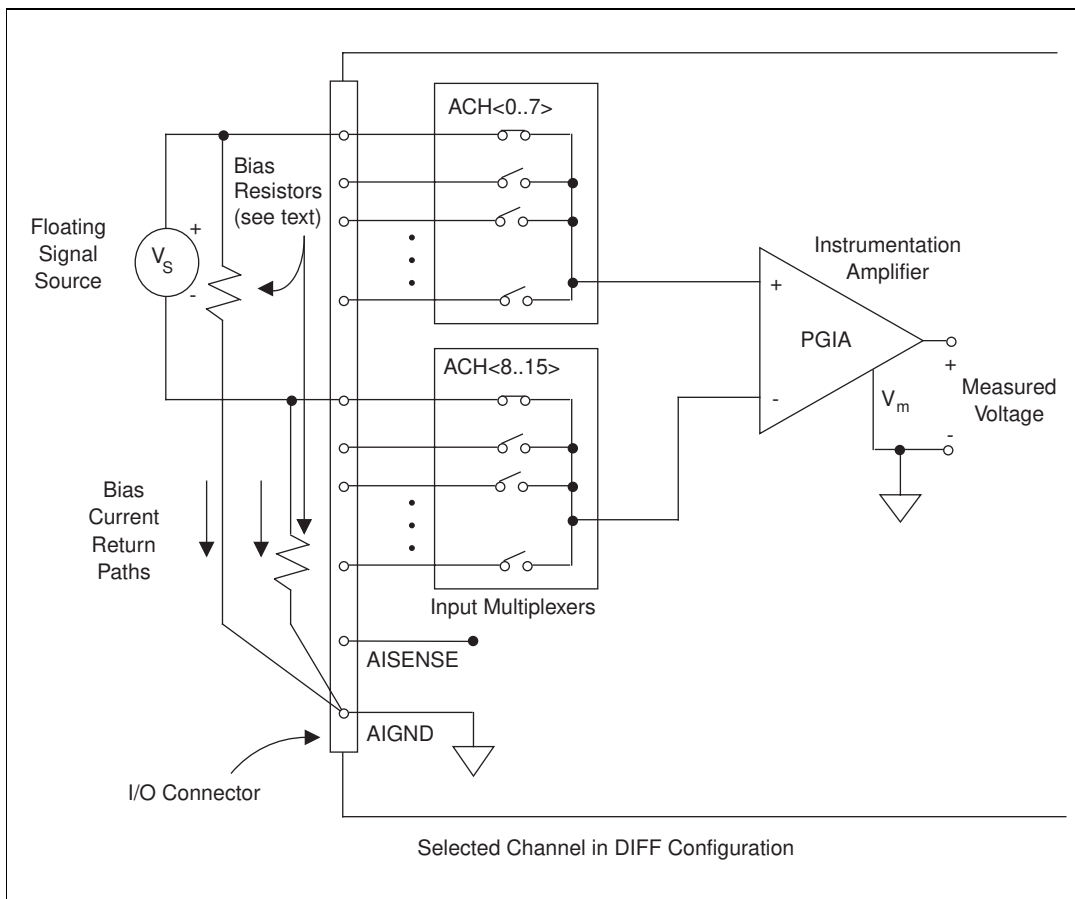

Figure 4-5. Differential Input Connections for Nonreferenced Signals

Figure 4-5 shows two bias resistors connected in parallel with the signal leads of a floating signal source. If you do not use the resistors and the source is truly floating, the source is not likely to remain within the common-mode signal range of the PGIA, and the PGIA will saturate, causing erroneous readings. You must reference the source to AIGND. The easiest way is simply to connect the positive side of the signal to the positive input of the PGIA and connect the negative side of the signal

to AIGND as well as to the negative input of the PGIA, without any resistors at all. This connection works well for DC-coupled sources with low source impedance (less than 100 Ω).

However, for larger source impedances, this connection leaves the differential signal path significantly out of balance. Noise that couples electrostatically onto the positive line does not couple onto the negative line because it is connected to ground. Hence, this noise appears as a differential-mode signal instead of a common-mode signal, so the PGIA does not reject it. In this case, instead of directly connecting the negative line to AIGND, connect it to AIGND through a resistor that is about 100 times the equivalent source impedance. The resistor puts the signal path nearly in balance, so that about the same amount of noise couples onto both connections, yielding better rejection of electrostatically coupled noise. Also, this configuration does not load down the source (other than the very high input impedance of the PGIA).

You can fully balance the signal path by connecting another resistor of the same value between the positive input and AIGND, as shown in Figure 4-5. This fully-balanced configuration offers slightly better noise rejection but has the disadvantage of loading the source down with the DAQCard combination (sum) of the two resistors. If, for example, the source impedance is 2 k Ω and each of the two resistors is 100 k Ω , the resistors load down the source with 200 k Ω and produce a -1% gain error.

Both inputs of the PGIA require a DC path to ground in order for the PGIA to work. If the source is AC coupled (capacitively coupled), the PGIA needs a resistor between the positive input and AIGND. If the source has low impedance, choose a resistor that is large enough not to significantly load the source but small enough not to produce significant input offset voltage as a result of input bias current (typically 100 k Ω to 1 M Ω). In this case, you can tie the negative input directly to AIGND. If the source has high output impedance, balance the signal path as previously described using the same value resistor on both the positive and negative inputs; be aware that there is some gain error from loading down the source.

Single-Ended Connection Considerations

A single-ended connection is one in which the DAQCard E Series card analog input signal is referenced to a ground that can be shared with other input signals. The input signal is tied to the positive input of the PGIA, and the ground is tied to the negative input of the PGIA.

When every channel is configured for single-ended input, up to 16 analog input channels are available.

Use single-ended input connections for any input signal that meets the following conditions:

- The input signal is high level (greater than 1 V).
- The leads connecting the signal to the DAQCard are less than 10 ft (3 m).
- The input signal can share a common reference point with other signals.

DIFF input connections are recommended for greater signal integrity for any input signal that does not meet the preceding conditions.

You can software-configure the DAQCard channels for two different types of single-ended connections—RSE configuration and NRSE configuration. Use the RSE configuration for floating signal sources; in this case, the DAQCard provides the reference ground point for the external signal. Use the NRSE input configuration for ground-referenced signal sources; in this case, the external signal supplies its own reference ground point and the DAQCard should not supply one.

In single-ended configurations, more electrostatic and magnetic noise couples into the signal connections than in differential configurations. The coupling is the result of differences in the signal path. Magnetic coupling is proportional to the area between the two signal conductors. Electrical coupling is a function of how much the electric field differs between the two conductors.

Single-Ended Connections for Floating Signal Sources (RSE Configuration)

Figure 4-6 shows how to connect a floating signal source to a channel on a DAQCard configured for RSE mode.

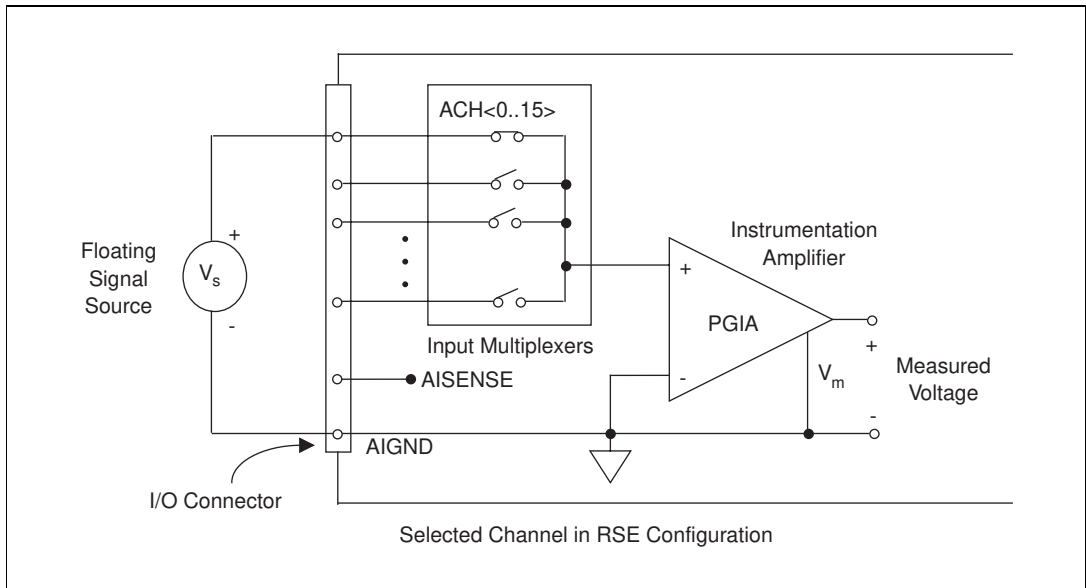

Figure 4-6. Single-Ended Input Connections for Nonreferenced or Floating Signals

Single-Ended Connections for Grounded Signal Sources (NRSE Configuration)

To measure a grounded signal source with a single-ended configuration, you must configure your DAQCard in the NRSE input configuration. The signal is then connected to the positive input of the DAQCard PGIA, and the signal local ground reference is connected to the negative input of the PGIA. The ground point of the signal should, therefore, be connected to the AISENSE pin. Any potential difference between the DAQCard ground and the signal ground appears as a common-mode signal at both the positive and negative inputs of the PGIA, and this difference is rejected by the amplifier. If the input circuitry of a DAQCard were referenced to ground, in this situation as in the RSE input configuration, this difference in ground potentials would appear as an error in the measured voltage.

Figure 4-7 shows how to connect a grounded signal source to a channel on a DAQCard configured for NRSE mode.

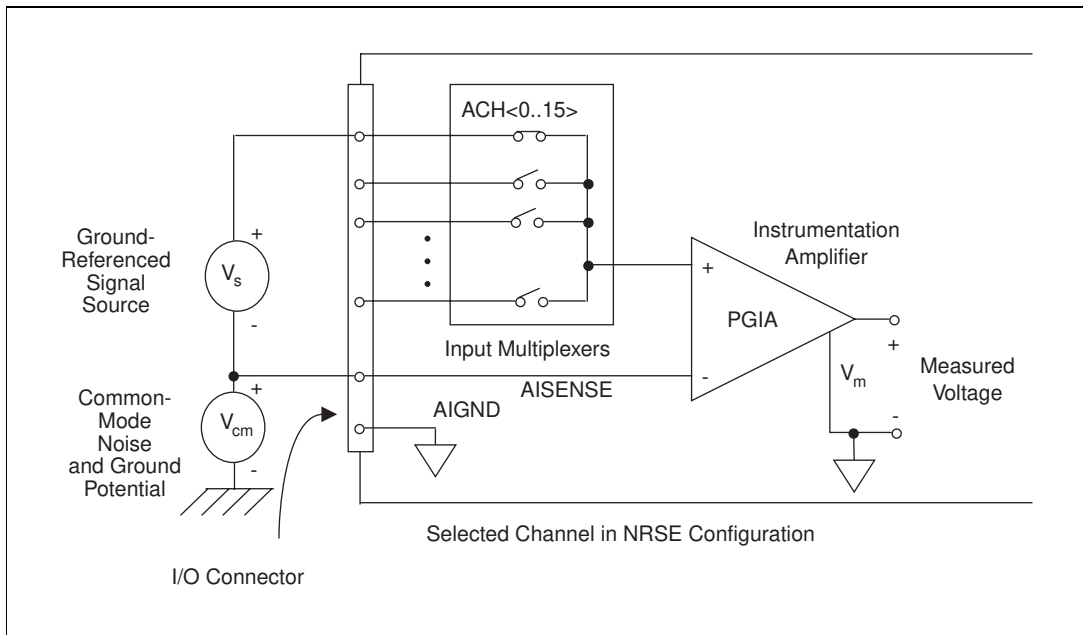

Figure 4-7. Single-Ended Input Connections for Ground-Referenced Signals

Common-Mode Signal Rejection Considerations

Figures 4-4 and 4-7 show connections for signal sources that are already referenced to some ground point with respect to the DAQCard. In these cases, the PGIA can reject any voltage caused by ground potential differences between the signal source and the DAQCard. In addition, with differential input connections, the PGIA can reject common-mode noise pickup in the leads connecting the signal sources to the DAQCard. The PGIA can reject common-mode signals as long as V_{in}^+ and V_{in}^- are both within ± 11 V of AIGND. The DAQCard-AI-16XE-50 has the additional restriction that $(V_{in}^+ + V_{in}^-)$ added to the gain times $(V_{in}^+ - V_{in}^-)$ must be within ± 26 V of AIGND. At gains of 10 and 100, this is roughly equivalent to restricting the two input voltages to within ± 8 V of AIGND.

Digital I/O Signal Connections

The digital I/O signals are DIO<0..7> and DGND. The DIO<0..7> signals make up the DIO port, and DGND is the ground reference signal for this port. You can program all lines individually to be inputs or outputs.



Warning *Exceeding the maximum input voltage ratings, which are listed in Tables 4-2 through 4-3, can damage the DAQCard and the computer. National Instruments is NOT liable for any damages resulting from such signal connections.*

Figure 4-8 shows signal connections for three typical digital I/O applications.

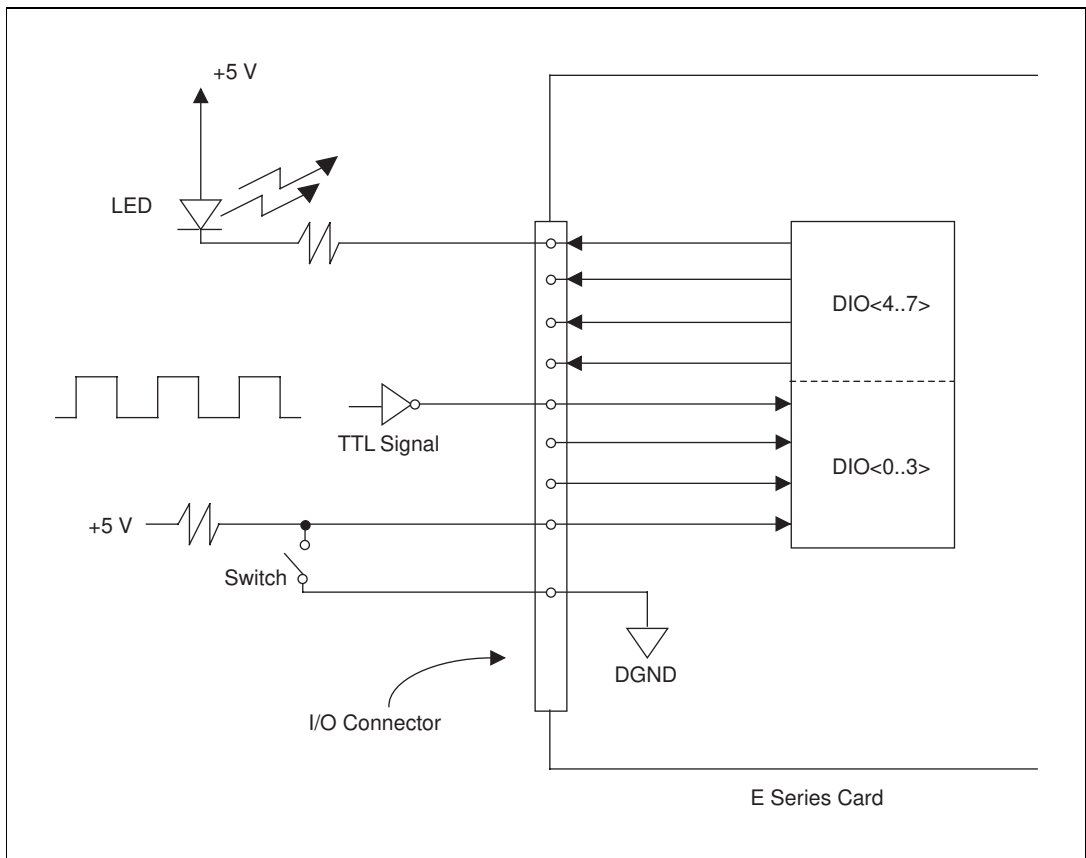

Figure 4-8. Digital I/O Connections

Figure 4-8 shows DIO<0..3> configured for digital input and DIO<4..7> configured for digital output. Digital input applications include receiving TTL signals and sensing external device states such as the state of the switch shown in the figure. Digital output applications include sending TTL signals and driving external devices such as the LED shown in the figure.

Power Connections

Two pins on the I/O connector supply +5 V from the computer power supply via a self-resetting fuse. The fuse will reset automatically within a few seconds after the overcurrent condition is removed. These pins are referenced to DGND and can be used to power external digital circuitry.

- Power rating +4.65 to +5.25 VDC at 250 mA



Warning *Do not, under any circumstances, connect these +5 V power pins directly to analog or digital ground or to any other voltage source on the DAQCard or any other device. Doing so can damage the DAQCard and the computer. National Instruments is NOT liable for damages resulting from such a connection.*

Timing Connections



Warning *Exceeding the maximum input voltage ratings, which are listed in Tables 4-2 through 4-3, can damage the DAQCard and the computer. National Instruments is NOT liable for any damages resulting from such signal connections.*

All external control over the timing of your DAQCard is routed through the 10 programmable function inputs labeled PFI0 through PFI9. These signals are explained in detail in the [Programmable Function Input Connections](#) section. These PFIs are bidirectional; as outputs they are not programmable and reflect the state of many data acquisition, waveform generation, and general-purpose timing signals. There are five other dedicated outputs for the remainder of the timing signals. As inputs, the PFI signals are programmable and can control any data acquisition, waveform generation, and general-purpose timing signals.

The data acquisition signals are explained in the [Data Acquisition Timing Connections](#) section later in this chapter. The general-purpose timing signals are explained in the [General-Purpose Timing Signal Connections](#) section later in this chapter.

All digital timing connections are referenced to DGND. This reference is demonstrated in Figure 4-9, which shows how to connect an external TRIG1 source and an external CONVERT* source to two of the DAQCard PFI pins.

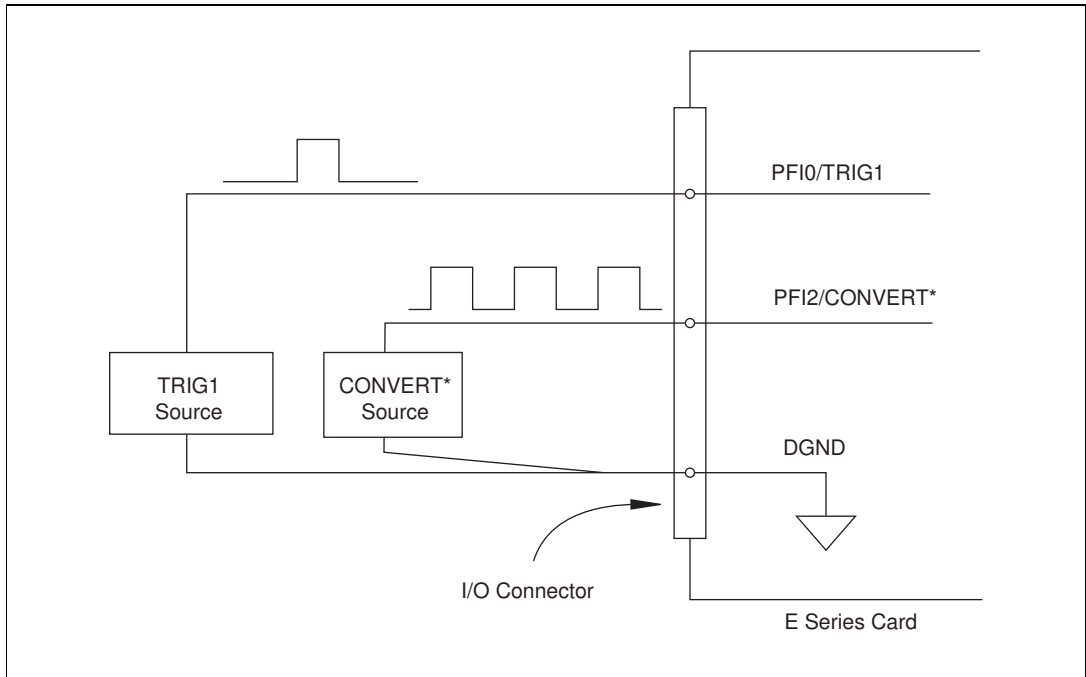

Figure 4-9. Timing I/O Connections

Programmable Function Input Connections

There are a total of 13 internal timing signals that you can externally control from the PFI pins. The source for each of these signals is software selectable from any of the PFIs when you want external control. This flexible routing scheme reduces the need to change the physical wiring to the DAQCard I/O connector for different applications requiring alternative wiring.

You can individually enable each of the PFI pins to output a specific internal timing signal. For example, if you need the CONVERT* signal as an output on the I/O connector, software can turn on the output driver for the PFI2/CONVERT* pin. Be careful not to drive a PFI signal externally when it is configured as an output.

As an input, you can individually configure each PFI for edge or level detection and for polarity selection, as well. You can use the polarity selection for any of the 13 timing signals, but the edge or level detection will depend upon the particular timing signal being controlled. The detection requirements for each timing signal are listed within the section that discusses that individual signal.

In edge-detection mode, the minimum pulse width required is 10 ns. This applies for both rising-edge and falling-edge polarity settings. There is no maximum pulse-width requirement in edge-detection mode.

In level-detection mode, there are no minimum or maximum pulse-width requirements imposed by the PFIs themselves, but there may be limits imposed by the particular timing signal being controlled. These requirements are listed later in this chapter.

Data Acquisition Timing Connections

The data acquisition timing signals are SCANCLK, EXTSTROBE*, TRIG1, TRIG2, STARTSCAN, CONVERT*, AIGATE, and SISOURCE.

Posttriggered data acquisition allows you to view only data that is acquired after a trigger event is received. A typical posttriggered data acquisition sequence is shown in Figure 4-10. Pretriggered data acquisition allows you to view data that is acquired before the trigger of interest in addition to data acquired after the trigger. Figure 4-11 shows a typical pretriggered data acquisition sequence. The description for each signal shown in these figures is included later in this chapter.

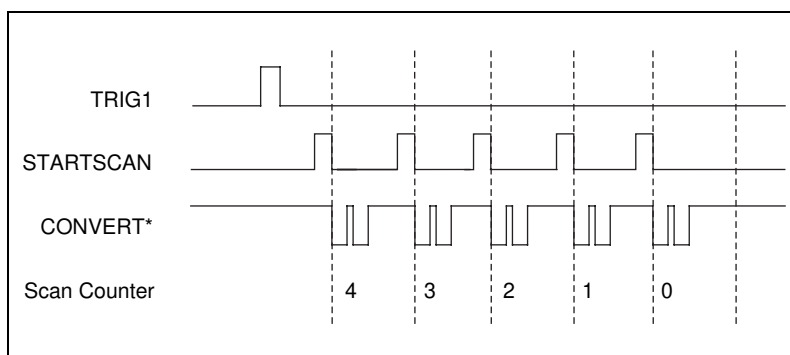

Figure 4-10. Typical Posttriggered Acquisition

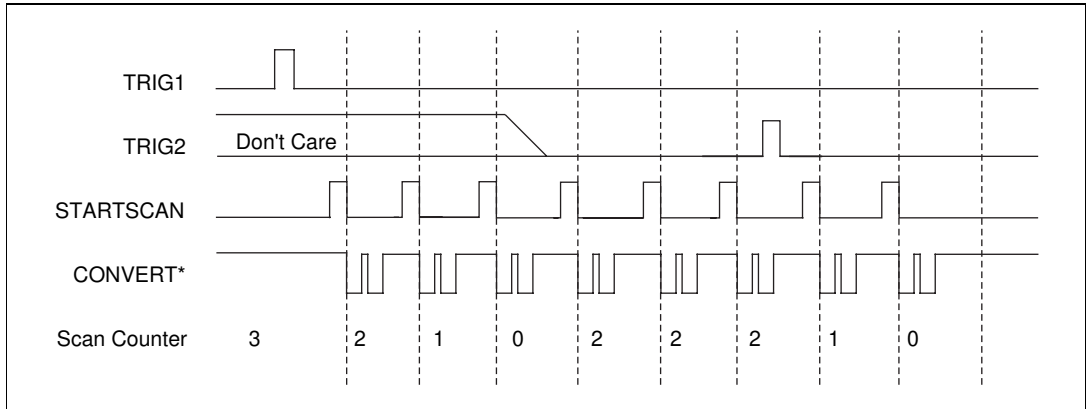

Figure 4-11. Typical Pretriggered Acquisition

SCANCLK Signal

SCANCLK is an output-only signal that generates a pulse with the leading edge occurring approximately 50 to 100 ns after an A/D conversion begins. The polarity of this output is software-selectable but is typically configured so that a low-to-high leading edge can clock external analog input multiplexers indicating when the input signal has been sampled and can be removed. This signal has a 400 to 500 ns pulse width and is software enabled. Figure 4-12 shows the timing for the SCANCLK signal.

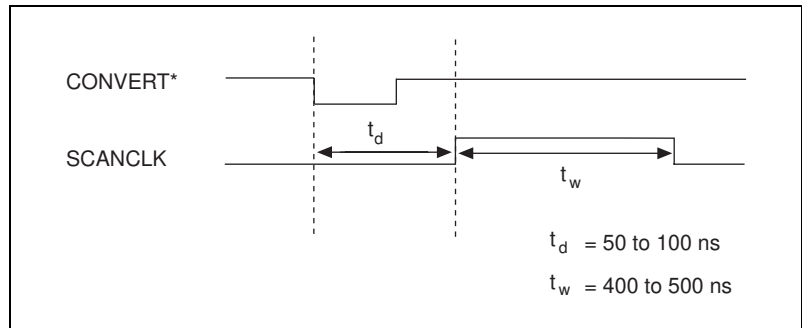

Figure 4-12. SCANCLK Signal Timing

EXTSTROBE* Signal

EXTSTROBE* is an output-only signal that generates either a single pulse or a sequence of eight pulses in the hardware-strobe mode. An external device can use this signal to latch signals or to trigger events. In the single-pulse mode, software controls the level of the EXTSTROBE*

signal. A 10 and 1.2 μs clocks are available for generating a sequence of eight pulses in the hardware-strobe mode. This signal is primarily used for SCXI and AMUX-64T communication. To control this signal for general-purpose use, you will have to perform register-level programming. Figure 4-13 shows the timing for the hardware-strobe mode EXTSTROBE* signal.

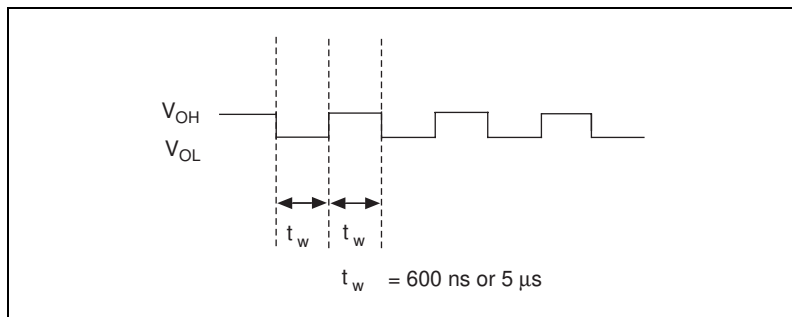

Figure 4-13. EXTSTROBE* Signal Timing

TRIG1 Signal

Any PFI pin can externally input the TRIG1 signal, which is available as an output on the PFI0/TRIG1 pin.

Refer to Figures 4-10 and 4-11 for the relationship of TRIG1 to the data acquisition sequence.

As an input, the TRIG1 signal is configured in the edge-detection mode. You can select any PFI pin as the source for TRIG1 and configure the polarity selection for either rising or falling edge. The selected edge of the TRIG1 signal starts the data acquisition sequence for both posttriggered and pretriggered acquisitions. The DAQCards support analog triggering on the PFI0/TRIG1 pin. See Chapter 3, [Hardware Overview](#), for more information on analog triggering.

As an output, the TRIG1 signal reflects the action that initiates a data acquisition sequence. This is true even if the acquisition is being externally triggered by another PFI. The output is an active high pulse with a pulse width of 50 to 100 ns. This output is set to tri-state at startup.

Figures 4-14 and 4-15 show the input and output timing requirements for the TRIG1 signal.

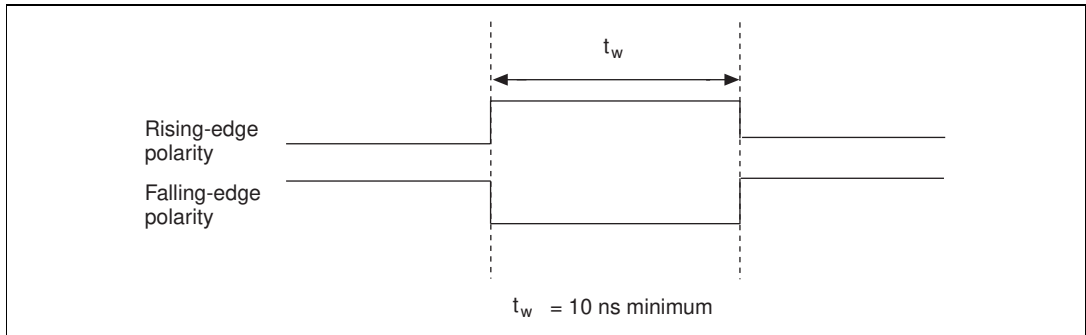

Figure 4-14. TRIG1 Input Signal Timing

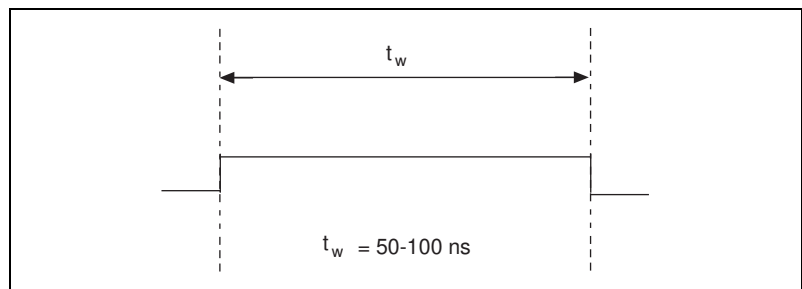

Figure 4-15. TRIG1 Output Signal Timing

The DAQCard also uses the TRIG1 signal to initiate pretriggered data acquisition operations. In most pretriggered applications, the TRIG1 signal is generated by a software trigger. Refer to the TRIG2 signal description for a complete description of the use of TRIG1 and TRIG2 in a pretriggered data acquisition operation.

TRIG2 Signal

Any PFI pin can externally input the TRIG2 signal, which is available as an output on the PFI1/TRIG2 pin.

Refer to Figure 4-11 for the relationship of TRIG2 to the data acquisition sequence.

As an input, the TRIG2 signal is configured in the edge-detection mode. You can select any PFI pin as the source for TRIG2 and configure the polarity selection for either rising or falling edge. The selected edge

of the TRIG2 signal initiates the posttriggered phase of a pretriggered acquisition sequence. In pretriggered mode, the TRIG1 signal initiates the data acquisition. The scan counter indicates the minimum number of scans before TRIG2 can be recognized. After the scan counter decrements to zero, it is loaded with the number of posttrigger scans to acquire while the acquisition continues. The DAQCard ignores the TRIG2 signal if it is asserted prior to the scan counter decrementing to zero. After the selected edge of TRIG2 is received, the DAQCard acquires a fixed number of scans and the acquisition stops. This mode acquires data both before and after receiving TRIG2.

As an output, the TRIG2 signal reflects the posttrigger in a pretriggered acquisition sequence. This is true even if the acquisition is being externally triggered by another PFI. The TRIG2 signal is not used in posttriggered data acquisition. The output is an active high pulse with a pulse width of 50 to 100 ns. This signal is set to input (High-Z) at startup.

Figures 4-16 and 4-17 show the input and output timing requirements for the TRIG2 signal.

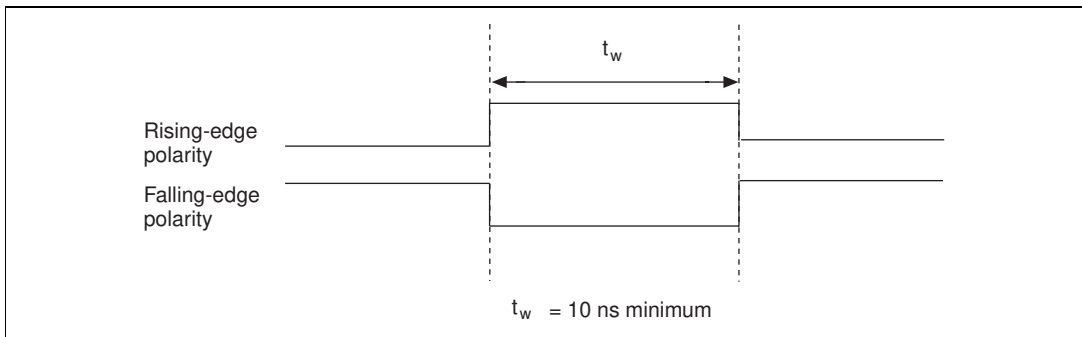

Figure 4-16. TRIG2 Input Signal Timing

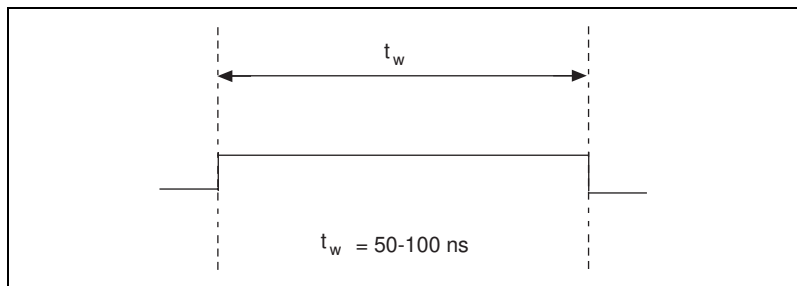

Figure 4-17. TRIG2 Output Signal Timing

STARTSCAN Signal

Any PFI pin can externally input the STARTSCAN signal, which is available as an output on the PFI7/STARTSCAN pin.

Refer to Figures 4-10 and 4-11 for the relationship of STARTSCAN to the data acquisition sequence.

As an input, the STARTSCAN signal is configured in the edge-detection mode. You can select any PFI pin as the source for STARTSCAN and configure the polarity selection for either rising or falling edge. The selected edge of the STARTSCAN signal initiates a scan. The sample interval counter is started if you select internally triggered CONVERT*.

As an output, the STARTSCAN signal reflects the actual start pulse that initiates a scan. This is true even if the starts are externally triggered by another PFI. You have two output options. The first is an active high pulse with a pulse width of 50 to 100 ns, which indicates the start of the scan. The second action is an active high pulse that terminates at the start of the last conversion in the scan, which indicates a scan in progress. STARTSCAN will be deasserted t_{off} after the last conversion in the scan is initiated. This output is set to tri-state at startup.

Figures 4-18 and 4-19 show the input and output timing requirements for the STARTSCAN signal.

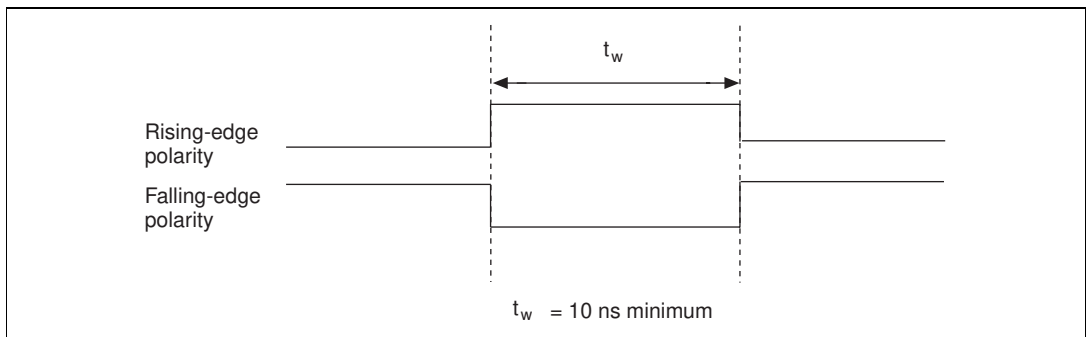

Figure 4-18. STARTSCAN Input Signal Timing

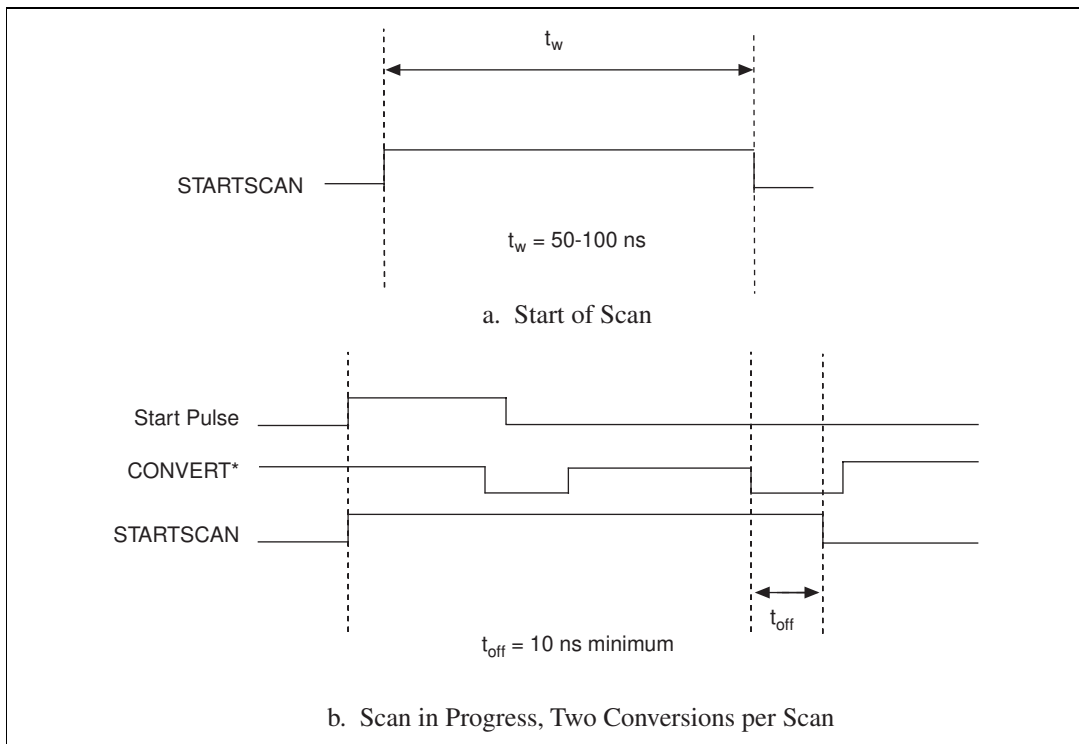

Figure 4-19. STARTSCAN Output Signal Timing

The CONVERT* pulses are masked off until the DAQCard generates the STARTSCAN signal. If you are using internally generated conversions, the first CONVERT* will appear when the onboard sample interval counter reaches zero. If you select an external CONVERT*, the first external pulse after STARTSCAN will generate a conversion. The STARTSCAN pulses should be separated by at least one scan period.

A counter on your DAQCard internally generates the STARTSCAN signal unless you select some external source. This counter is started by the TRIG1 signal and is stopped either by software or by the sample counter.

Scans generated by either an internal or external STARTSCAN signal are inhibited unless they occur within a data acquisition sequence. Scans occurring within a data acquisition sequence may be gated by either the hardware (AIGATE) signal or software command register gate.

CONVERT* Signal

Any PFI pin can externally input the CONVERT* signal, which is available as an output on the PFI2/CONVERT* pin.

Refer to Figures 4-10 and 4-11 for the relationship of STARTSCAN to the data acquisition sequence.

As an input, the CONVERT* signal is configured in the edge-detection mode. You can select any PFI pin as the source for CONVERT* and configure the polarity selection for either rising or falling edge. The selected edge of the CONVERT* signal initiates an A/D conversion.

As an output, the CONVERT* signal reflects the actual convert pulse that is connected to the ADC. This is true even if the conversions are externally generated by another PFI. The output is an active low pulse with a pulse width of 50 to 100 ns. This signal is set to input (High-Z) at startup.

Figures 4-20 and 4-21 show the input and output timing requirements for the CONVERT* signal.

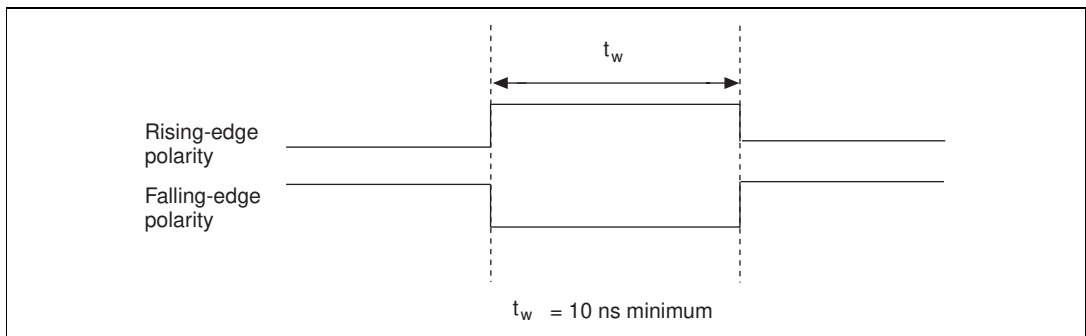

Figure 4-20. CONVERT* Input Signal Timing

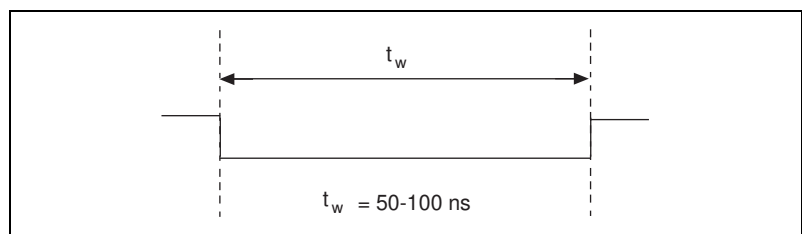

Figure 4-21. CONVERT* Output Signal Timing

The ADC switches to hold mode within 60 ns of the selected edge. This hold-mode delay time is a function of temperature and does not vary from one conversion to the next. Separate the CONVERT* pulses by at least one conversion period.

The sample interval counter on the DAQCard normally generates the CONVERT* signal unless you select some external source. The counter is started by the STARTSCAN signal and continues to count down and reload itself until the scan is finished. It then reloads itself in readiness for the next STARTSCAN pulse.

A/D conversions generated by either an internal or external CONVERT* signal are inhibited unless they occur within a data acquisition sequence. Scans occurring within a data acquisition sequence may be gated by either the hardware (AIGATE) signal or software command register gate.

AIGATE Signal

Any PFI pin can externally input the AIGATE signal, which is not available as an output on the I/O connector. The AIGATE signal can mask off scans in a data acquisition sequence. You can configure the PFI pin you select as the source for the AIGATE signal in either the level-detection or edge-detection mode. You can configure the polarity selection for the PFI pin for either active high or active low.

In the level-detection mode if AIGATE is active, the STARTSCAN signal is masked off and no scans can occur. In the edge-detection mode, the first active edge disables the STARTSCAN signal, and the second active edge enables STARTSCAN.

The AIGATE signal can neither stop a scan in progress nor continue a previously gated-off scan; in other words, once a scan has started, AIGATE does not gate off conversions until the beginning of the next scan and, conversely, if conversions are being gated off, AIGATE does not gate them back on until the beginning of the next scan.

SISOURCE Signal

Any PFI pin can externally input the SISOURCE signal, which is not available as an output on the I/O connector. The onboard scan interval counter uses the SISOURCE signal as a clock to time the generation of the STARTSCAN signal. You must configure the PFI pin you select as the source for the SISOURCE signal in the level-detection mode. You can configure the polarity selection for the PFI pin for either active high or active low.

The maximum allowed frequency is 20 MHz, with a minimum pulse width of 23 ns high or low. There is no minimum frequency limitation.

Either the 20 MHz or 100 kHz internal timebase generates the SISOURCE signal unless you select some external source. Figure 4-22 shows the timing requirements for the SISOURCE signal.

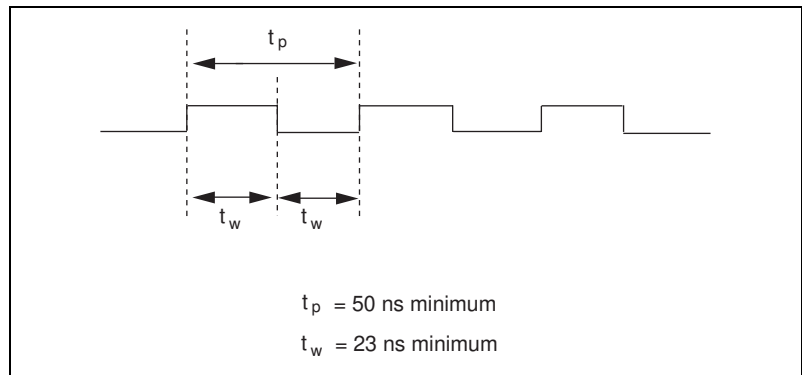

Figure 4-22. SISOURCE Signal Timing

UISOURCE Signal

Any PFI pin can externally input the UISOURCE signal, which is not available as an output on the I/O connector. The UI counter uses the UISOURCE signal as a clock to time the generation of the UPDATE* signal. You must configure the PFI pin you select as the source for the UISOURCE signal in the level-detection mode. You can configure the polarity selection for the PFI pin for either active high or active low. Figure 4-23 shows the timing requirements for the UISOURCE signal.

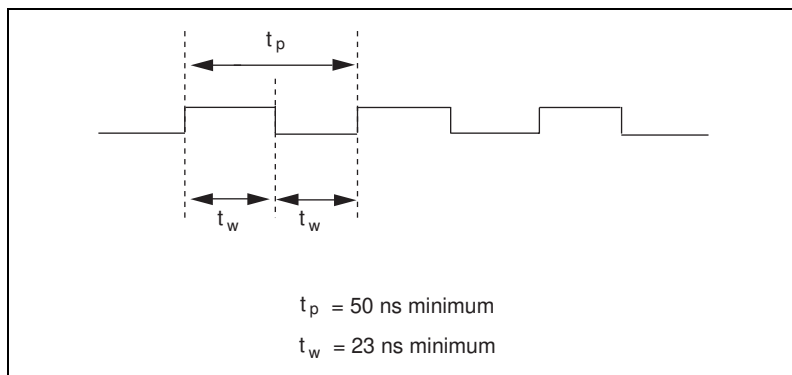

Figure 4-23. UISOURCE Signal Timing

The maximum allowed frequency is 20 MHz, with a minimum pulse width of 23 ns high or low. There is no minimum frequency limitation.

Either the 20 MHz or 100 kHz internal timebase normally generates the UISOURCE signal unless you select some external source.

General-Purpose Timing Signal Connections

The general-purpose timing signals are GPCTR0_SOURCE, GPCTR0_GATE, GPCTR0_OUT, GPCTR0_UP_DOWN, GPCTR1_SOURCE, GPCTR1_GATE, GPCTR1_OUT, GPCTR1_UP_DOWN, and FREQ_OUT.

GPCTR0_SOURCE Signal

Any PFI pin can externally input the GPCTR0_SOURCE signal, which is available as an output on the PFI8/GPCTR0_SOURCE pin.

As an input, the GPCTR0_SOURCE signal is configured in the edge-detection mode. You can select any PFI pin as the source for GPCTR0_SOURCE and configure the polarity selection for either rising or falling edge.

As an output, the GPCTR0_SOURCE signal reflects the actual clock connected to general-purpose counter 0. This is true even if another PFI is externally inputting the source clock. This signal is set to input (High-Z) at startup.

Figure 4-24 shows the timing requirements for the GPCTR0_SOURCE signal.

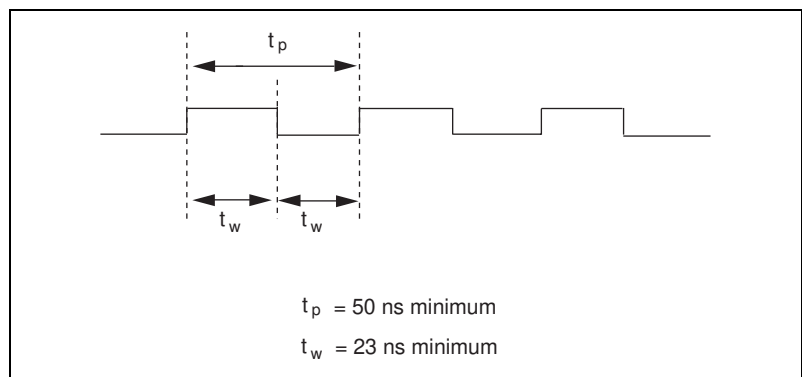

Figure 4-24. GPCTR0_SOURCE Signal Timing

The maximum allowed frequency is 20 MHz, with a minimum pulse width of 23 ns high or low. There is no minimum frequency limitation.

The 20 MHz or 100 kHz timebase normally generates the GPCTR0_SOURCE signal unless you select some external source.

GPCTR0_GATE Signal

Any PFI pin can externally input the GPCTR0_GATE signal, which is available as an output on the PFI9/GPCTR0_GATE pin.

As an input, the GPCTR0_GATE signal is configured in the edge-detection mode. You can select any PFI pin as the source for GPCTR0_GATE and configure the polarity selection for either rising or falling edge. You can use the gate signal in a variety of different applications to perform actions such as starting and stopping the counter, generating interrupts, saving the counter contents, and so on.

As an output, the GPCTR0_GATE signal reflects the actual gate signal connected to general-purpose counter 0. This is true even if the gate is being externally generated by another PFI. This signal is set to input (High-Z) at startup.

Figure 4-25 shows the timing requirements for the GPCTR0_GATE signal.

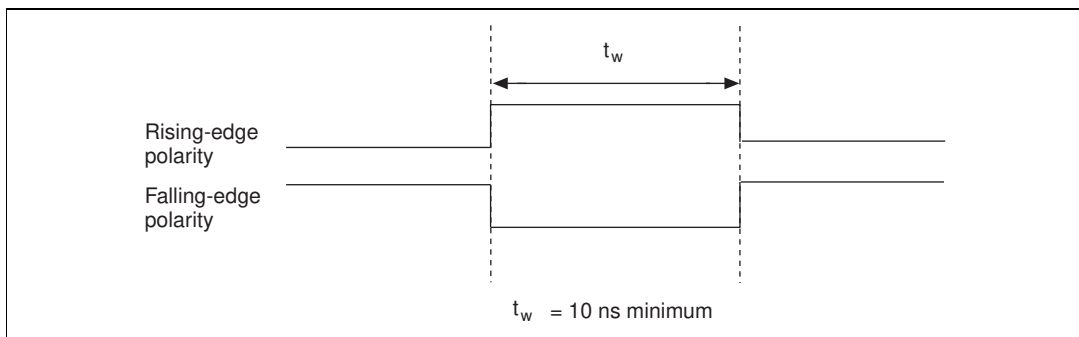

Figure 4-25. GPCTR0_GATE Signal Timing in Edge-Detection Mode

GPCTR0_OUT Signal

This signal is available only as an output on the GPCTR0_OUT pin. The GPCTR0_OUT signal reflects the terminal count (TC) of general-purpose counter 0. You have two software-selectable output options—pulse on TC and toggle output polarity on TC. The output polarity is software selectable for both options. This signal is set to input (High-Z) at startup. Figure 4-26 shows the timing of the GPCTR0_OUT signal.

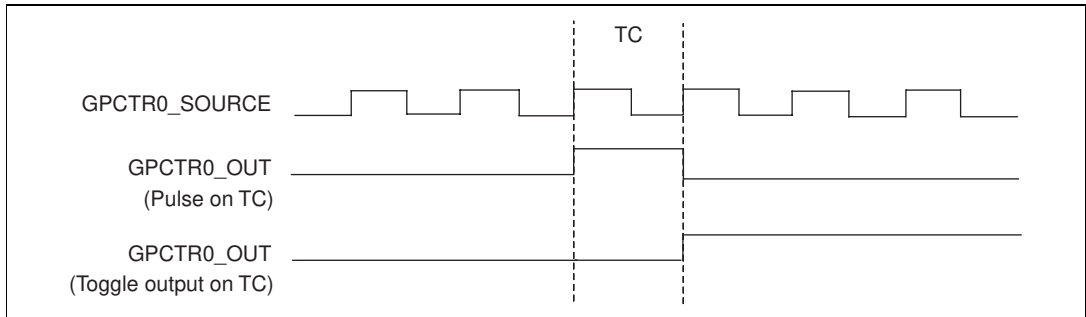

Figure 4-26. GPCTR0_OUT Signal Timing

GPCTR0_UP_DOWN Signal

This signal can be externally input on the DIO6 pin and is not available as an output on the I/O connector. The general-purpose counter 0 will count down when this pin is at a logic low and count up when it is at a logic high. You can disable this input so that software can control the up-down functionality and leave the DIO6 pin free for general use.

GPCTR1_SOURCE Signal

Any PFI pin can externally input the GPCTR1_SOURCE signal, which is available as an output on the PFI3/GPCTR1_SOURCE pin.

As an input, the GPCTR1_SOURCE signal is configured in the edge-detection mode. You can select any PFI pin as the source for GPCTR1_SOURCE and configure the polarity selection for either rising or falling edge.

As an output, the GPCTR1_SOURCE monitors the actual clock connected to general-purpose counter 1. This is true even if the source clock is being externally generated by another PFI. This signal is set to input (High-Z) at startup.

Figure 4-27 shows the timing requirements for the GPCTR1_SOURCE signal.

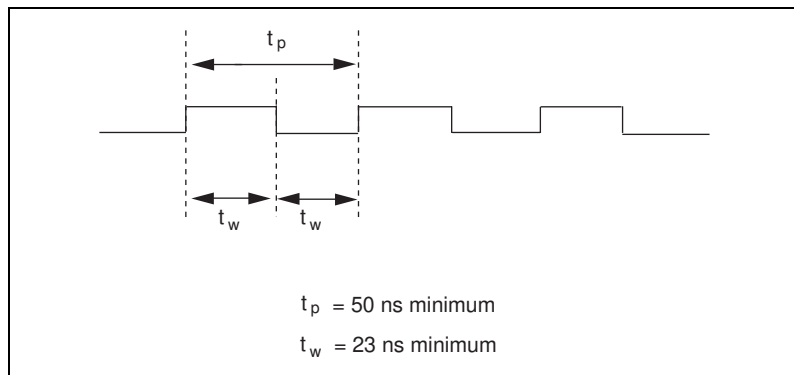

Figure 4-27. GPCTR1_SOURCE Signal Timing

The maximum allowed frequency is 20 MHz, with a minimum pulse width of 23 ns high or low. There is no minimum frequency limitation.

The 20 MHz or 100 kHz timebase normally generates the GPCTR1_SOURCE unless you select some external source.

GPCTR1_GATE Signal

Any PFI pin can externally input the GPCTR1_GATE signal, which is available as an output on the PFI4/GPCTR1_GATE pin.

As an input, the GPCTR1_GATE signal is configured in edge-detection mode. You can select any PFI pin as the source for GPCTR1_GATE and configure the polarity selection for either rising or falling edge. You can use the gate signal in a variety of different applications to perform such actions as starting and stopping the counter, generating interrupts, saving the counter contents, and so on.

As an output, the GPCTR1_GATE signal monitors the actual gate signal connected to general-purpose counter 1. This is true even if the gate is being externally generated by another PFI. This signal is set to input (High-Z) at startup.

Figure 4-28 shows the timing requirements for the GPCTR1_GATE signal.

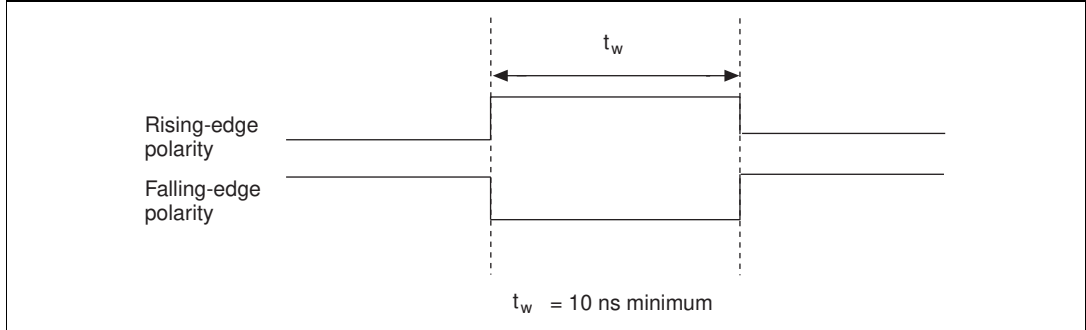

Figure 4-28. GPCTR1_GATE Signal Timing in Edge-Detection Mode

GPCTR1_OUT Signal

This signal is available only as an output on the GPCTR1_OUT pin. The GPCTR1_OUT signal monitors the TC board general-purpose counter 1. You have two software-selectable output options—pulse on TC and toggle output polarity on TC. The output polarity is software selectable for both options. This signal is set to input (High-Z) at startup. Figure 4-29 shows the timing requirements for the GPCTR1_OUT signal.

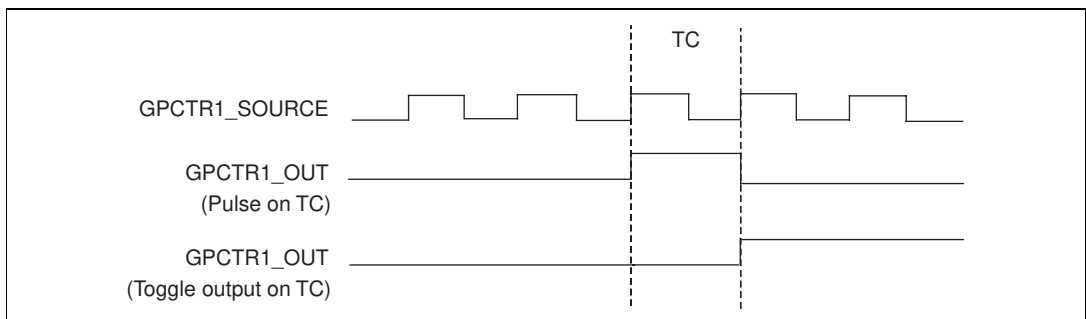

Figure 4-29. GPCTR1_OUT Signal Timing

GPCTR1_UP_DOWN Signal

This signal can be externally input on the DIO7 pin and is not available as an output on the I/O connector. General-purpose counter 1 counts down when this pin is at a logic low and counts up at a logic high. This input can be disabled so that software can control the up-down functionality and leave the DIO7 pin free for general use. Figure 4-30 shows the timing requirements for the GATE and SOURCE input signals and the timing specifications for the OUT output signals of your DAQCard.

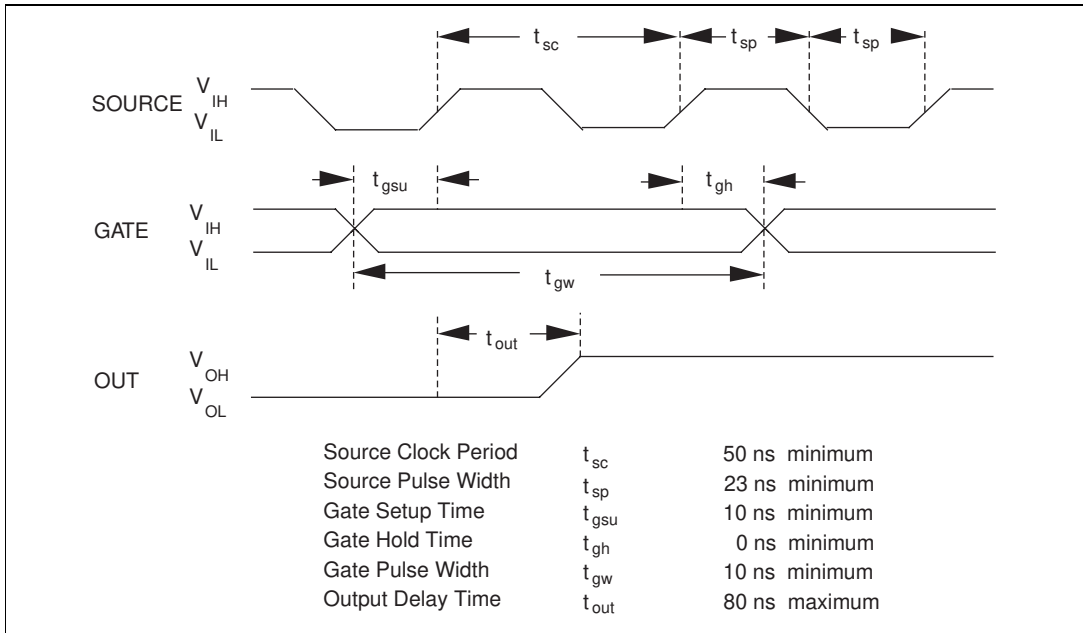

Figure 4-30. GPCTR Timing Summary

The GATE and OUT signal transitions shown in Figure 4-30 are referenced to the rising edge of the SOURCE signal. This timing diagram assumes that the counters are programmed to count rising edges. The same timing diagram, but with the source signal inverted and referenced to the falling edge of the source signal, would apply when the counter is programmed to count falling edges.

The GATE input timing parameters are referenced to the signal at the SOURCE input or to one of the internally generated signals on your DAQCard. Figure 4-30 shows the GATE signal referenced to the rising edge of a source signal. The gate must be valid (either high or low) for at least 10 ns before the rising or falling edge of a source signal for the gate

to take effect at that source edge, as shown by t_{gsu} and t_{gh} in Figure 4-30. The gate signal is not required to be held after the active edge of the source signal.

If an internal timebase clock is used, the gate signal cannot be synchronized with the clock. In this case, gates applied close to a source edge take effect either on that source edge or on the next one. This arrangement results in an uncertainty of one source clock period with respect to unsynchronized gating sources.

The OUT output timing parameters are referenced to the signal at the SOURCE input or to one of the internally generated clock signals on the DAQCards. Figure 4-30 shows the OUT signal referenced to the rising edge of a source signal. Any OUT signal state changes occur within 80 ns after the rising or falling edge of the source signal.

FREQ_OUT Signal

This signal is available only as an output on the FREQ_OUT pin. The FREQ_OUT signal is the output of the DAQCard frequency generator. The frequency generator is a 4-bit counter that can divide its input clock by the numbers 1 through 16. The input clock of the frequency generator is software selectable from the internal 10 MHz and 100 kHz timebases. The output polarity is software selectable. This signal is set to input (High-Z) at startup.

Field Wiring Considerations

Environmental noise can seriously affect the accuracy of measurements made with your DAQCard if you do not take proper care when running signal wires between signal sources and the DAQCard. The following recommendations apply mainly to analog input signal routing to the DAQCard, although they also apply to signal routing in general.

You can minimize noise pickup and maximize measurement accuracy by taking the following precautions:

- Use differential analog input connections to reject common-mode noise.
- Use individually shielded, twisted-pair wires to connect analog input signals to the DAQCard. With this type of wire, the signals attached to the CH+ and CH– inputs are twisted together and then covered with a shield. You then connect this shield only at one point to the signal

source ground. This kind of connection is required for signals traveling through areas with large magnetic fields or high electromagnetic interference.

- Route signals to the DAQCard carefully. Keep cabling away from noise sources. The most common noise source in a computer data acquisition system is the video monitor. Separate the monitor from the analog signals as much as possible.

The following recommendations apply for all signal connections to your DAQCard:

- Separate DAQCard signal lines from high-current or high-voltage lines. These lines are capable of inducing currents in or voltages on the DAQCard signal lines if they run in parallel paths at a close distance. To reduce the magnetic coupling between lines, separate them by a reasonable distance if they run in parallel, or run the lines at right angles to each other.
- Do not run signal lines through conduits that also contain power lines.
- Protect signal lines from magnetic fields caused by electric motors, welding equipment, breakers, or transformers by running them through special metal conduits.

Calibration

This chapter discusses the calibration procedures for your DAQCard E Series card. If you are using the NI-DAQ device driver, that software includes calibration functions for performing all of the steps in the calibration process.

Calibration refers to the process of minimizing measurement and output voltage errors by making small circuit adjustments. On the DAQCards, these adjustments take the form of writing values to onboard calibration DACs (CalDACs).

Some form of DAQCard calibration is required for all but the most forgiving applications. If no DAQCard calibration were performed, your signals and measurements could have very large offset, gain, and linearity errors.

Three levels of calibration are available to you, and these are described in this chapter. The first level is the fastest, easiest, and least accurate, whereas the last level is the slowest, most difficult, and most accurate.

Loading Calibration Constants

Your DAQCard is factory calibrated before shipment at approximately 25° C to the levels indicated in Appendix A, *Specifications*. The associated calibration constants—the values that were written to the CalDACs to achieve calibration in the factory—are stored in the onboard nonvolatile memory (EEPROM). Because the CalDACs have no memory capability, they do not retain calibration information when the DAQCard is unpowered. Loading calibration constants refers to the process of loading the CalDACs with the values stored in the EEPROM. NI-DAQ software determines when this is necessary and does it automatically. If you are not using NI-DAQ, you must load these values yourself.

In the EEPROM there is a user-modifiable calibration area in addition to the permanent factory calibration area. This means that you can load the CalDACs with values either from the original factory calibration or from a calibration that you subsequently performed.

This method of calibration is not very accurate because it does not take into account the fact that the DAQCard measurement and output voltage errors can vary with time and temperature. It is better to self-calibrate when the DAQCard is installed in the environment in which it will be used.

Self-Calibration

Your DAQCard can measure and correct for almost all of its calibration-related errors without any external signal connections. Your National Instruments software provides a self-calibration method you can use. This self-calibration process, which generally takes less than a minute, is the preferred method of assuring accuracy in your application. Initiate self-calibration to minimize the effects of any offset, gain, and linearity drifts, particularly those due to warmup.

Immediately after self-calibration, the only significant residual calibration error could be gain error due to time or temperature drift of the onboard voltage reference. This error is addressed by external calibration, which is discussed in the following section. If you are interested primarily in relative measurements, you can ignore a small amount of gain error, and self-calibration should be sufficient.

External Calibration

Your DAQCard has an onboard calibration reference to ensure the accuracy of self-calibration. Its specifications are listed in Appendix A, *Specifications*. The reference voltage is measured at the factory and stored in the EEPROM for subsequent self-calibrations. This voltage is stable enough for most applications, but if you are using your DAQCard at an extreme temperature or if the onboard reference has not been measured for a year or more, you may wish to externally calibrate your DAQCard.

An external calibration refers to calibrating your DAQCard with a known external reference rather than relying on the onboard reference. Redetermining the value of the onboard reference is part of this process and the results can be saved in the EEPROM, so you should not have to perform an external calibration very often. You can externally calibrate your DAQCard by calling the NI-DAQ calibration function.

To externally calibrate your DAQCard, use a very accurate external reference. The reference should be several times more accurate than the DAQCard itself. For example, to calibrate a 12-bit DAQCard, the external reference should be at least $\pm 0.005\%$ (± 50 ppm) accurate. To calibrate a 16-bit DAQCard, the external reference should be at least $\pm 0.001\%$ (± 10 ppm) accurate.

Other Considerations

The CalDACs adjust the gain error of each analog output channel by adjusting the value of the reference voltage supplied to that channel. This calibration mechanism is designed to work only with the internal 10 V reference. Thus, in general, it is not possible to calibrate the analog output gain error when using an external reference. In this case, it is advisable to account for the nominal gain error of the analog output channel either in software or with external hardware. See Appendix A, *Specifications*, for analog output gain error information.

Specifications

This appendix lists the specifications of each DAQCard in the DAQCard E Series. These specifications are typical at 25° C unless otherwise noted.

DAQCard-AI-16E-4

Analog Input

Input Characteristics

Number of channels	16 single-ended, 16 pseudo-differential, or 8 differential (software-selectable on a per channel basis)
Type of ADC.....	Successive approximation
Resolution	12 bits, 1 in 4,096
Max sampling rate.....	250 kS/s guaranteed

Input signal ranges

Board Gain (Software Selectable)	Board Range (Software Selectable)	
	Bipolar	Unipolar
0.5	±10 V	—
1	±5 V	0 to 10 V
2	±2.5 V	0 to 5 V
5	±1	0 to 2 V
10	±500 mV	0 to 1 V
20	±250 mV	0 to 500 mV
50	±100 mV	0 to 200 mV
100	±50 mV	0 to 100 mV

Input coupling.....DC

Max working voltage
(signal + common mode).....Each input should remain within
±11 V of ground

Overvoltage protection±25 V powered on, ±15 V
powered off

Inputs protectedACH<0..15>, AISENSE

FIFO buffer size.....1,024 samples

Data transfersinterrupt, programmed I/O

Configuration memory size512 words

Transfer Characteristics

Relative accuracy	± 0.5 LSB typ dithered, ± 1.5 LSB max undithered
DNL	± 0.5 LSB typ, ± 1.0 LSB max
No missing codes	12 bits, guaranteed
Offset error	
Pregain error after calibration	± 16 μ V max
Pregain error before calibration	± 4.0 mV max
Postgain error after calibration	± 1.0 mV max
Postgain error before calibration.....	± 265 mV max
Gain error (relative to calibration reference)	
After calibration (gain = 1)	$\pm 0.02\%$ of reading max
Before calibration	$\pm 2.5\%$ of reading max
Gain $\neq 1$ with gain error adjusted to 0 at gain = 1	$\pm 0.02\%$ of reading max

Amplifier Characteristics

Input impedance	
Normal powered on	100 Ω in parallel with 100 pF
Powered off	1 $k\Omega$ min
Overload.....	1 $k\Omega$ min
Input bias current	± 200 pA
Input offset current.....	± 100 pA
CMRR (all input ranges, DC to 60 Hz)	
Gain ≤ 1	85 dB
Gain = 2	95 dB
Gain ≥ 5	100 dB

Dynamic Characteristics

Bandwidth	
Small signal (-3 dB)	800 kHz
Large signal (1% THD)	400 kHz

Settling time for full-scale step

Gain	Accuracy	
	$\pm 0.012\%$ (± 0.5 LSB)	$\pm 0.024\%$ (± 1 LSB)
0.5	4 μ s typ, 8 μ s max	4 μ s max

System noise in LSB rms, not including quantization

Gain	Noise, dither off	Noise, dither on
0.5 to 10	0.2	—
0.5 to 20	—	0.5
20	0.25	—
50	0.5	0.7
100	0.9	1.0

Crosstalk-80 dB, DC to 100 kHz

Stability

Offset temperature coefficient

Pregain $\pm 5 \mu\text{V}/^\circ\text{C}$

Postgain $\pm 240 \mu\text{V}/^\circ\text{C}$

Gain temperature coefficient $\pm 20 \text{ ppm}/^\circ\text{C}$

Digital I/O

Number of channels 8 input/output

Compatibility TTL/CMOS

Digital logic levels

Level	Min	Max
Input low voltage	0 V	0.8 V
Input high voltage	2 V	5 V
Input low current ($V_{in} = 0$ V)	—	-320 μ A
Input high current ($V_{in} = 5$ V)	—	10 μ A
Output low voltage ($I_{OL} = 24$ mA)	—	0.4 V
Output high voltage ($I_{OH} = 13$ mA)	4.35 V	—

Power-on state Input (High-Z)

Data transfers Programmed I/O

Timing I/O

Number of channels 2 up/down counter/timers,
1 frequency scaler

Resolution

Counter/timers 24 bits

Frequency scalars 4 bits

Compatibility TTL/CMOS

Base clocks available

Counter/timers 20 MHz, 100 kHz

Frequency scalars 10 MHz, 100 kHz

Base clock accuracy $\pm 0.01\%$

Max source frequency 20 MHz

Min source pulse duration 10 ns in edge-detection mode

Min gate pulse duration10 ns in edge-detection mode

Data transfersinterrupts, programmed I/O

Triggers

Analog Trigger

SourceACH<0..15>, external trigger
(PFIO/TRIG1)

Level± full-scale, internal;
±10 V, external

SlopePositive or negative
(software selectable)

Resolution8 bits, 1 in 256

Hysteresis.....Programmable

Bandwidth (–3 dB)2.0 MHz internal,
3.0 MHz external

External input (PFIO/TRIG1)

Impedance.....10 kΩ

CouplingDC

Protection.....±35 V powered off,
–0.5 to VCC when configured as
a digital signal,
±35 V when configured as an
analog trigger signal or disabled

Digital Trigger

CompatibilityTTL

ResponseRising or falling edge

Pulse width10 ns min

Calibration

Recommended warm-up time15 min

Calibration interval1 year

External calibration reference	>6 and <9.999 V
Onboard calibration reference	
Level	5.000 V (± 2.5 mV) (actual value stored in EEPROM)
Temperature coefficient.....	± 5 ppm/ $^{\circ}$ C max
Long-term stability	± 15 ppm/ $\sqrt{1,000}$ h

Power Requirement (from PCMCIA I/O channel)

+5 VDC ($\pm 5\%$).....	280 mA typ in operational mode, 400 mA max in operational mode, 70 mA in power down mode
Power available at I/O connector.....	+4.65 to +5.25 V at 250 mA



Note

These power usage figures do not include the power used by external devices that are connected to the fused supply present on the I/O connector.

Note also that under ordinary operation, the DAQCard has a current requirement of 270–290 mA; but if the analog inputs being sampled are overdriven at high gains, or if the analog inputs are left floating when the DAQCard is not in use, the current may increase to 400 mA.

You can save current by using the NI-DAQ power down utility when your DAQCard is not in use.

Physical

PC Card type	Type II
I/O connector.....	PCMCIA 68-position female connector

Environment

Operating temperature.....	0 $^{\circ}$ to 55 $^{\circ}$ C
Storage temperature	-55 $^{\circ}$ to 150 $^{\circ}$ C
Relative humidity	5% to 90% noncondensing

DAQCard-AI-16XE-50

Analog Input

Input Characteristics

Number of channels 16 single-ended or 8 differential
(software-selectable)

Type of ADC Successive approximation

Resolution 16 bits, 1 in 65,536

Maximum sampling rate 200 kS/s (single-channel),
20 kS/s guaranteed
(scanning; gain = 1, 2, 10),
17 kS/s (scanning; gain = 100)

Input signal ranges

Board Gain (Software Selectable)	Board Range (Software Selectable)	
	Bipolar	Unipolar
1	±10 V	0 to 10 V
2	±5 V	0 to 5 V
10	±1 V	0 to 1 V
100	±0.1 V	0 to 0.1 V

Input coupling DC

Maximum working voltage
(signal + common mode) The average voltage of each
differential pair should remain
within ±8 V of ground

Overvoltage protection ±25 V powered on,
±15 V powered off

Inputs protected ACH<0..15>, AISENSE

FIFO buffer size 1,024 S

Data transfers interrupt, programmed I/O

Configuration memory size..... 512 words

Transfer Characteristics

Relative accuracy ± 1.5 LSB typ, ± 2.0 LSB max

DNL $+1.5, -0.75$ LSB typ,
 $+2.25, -1.0$ LSB max

No missing codes 16 bits, guaranteed

Offset error

Pregain error after calibration ± 3 μ V max

Pregain error before calibration ± 280 μ V max

Postgain error after calibration ± 162 μ V max (bipolar),
 ± 81 μ V max (unipolar)

Postgain error before calibration..... ± 37.5 mV max (bipolar),
 ± 175.75 mV max (unipolar)

Gain error (relative to calibration reference)

After calibration (gain = 1) ± 7.6 ppm of reading max

Before calibration $\pm 27,650$ ppm of reading max

With gain error adjusted to 0 at gain = 1

Gain = 2, 10 ± 100 ppm of reading

Gain = 100 ± 250 ppm of reading

Amplifier Characteristics

Input impedance

Normal, powered on $7\text{ G}\Omega$ in parallel with 100 pF

Powered off..... $1\text{ k}\Omega$ min

Overload..... $1\text{ k}\Omega$ min

Input bias current ± 10 nA

Input offset current..... ± 14 nA

CMRR, DC to 60 Hz

Gain = 1	80 dB
Gain = 2	86 dB
Gain = 10	100 dB
Gain = 100	120 dB

Dynamic Characteristics

Bandwidth

Gain = 1, 2	69 kHz
Gain = 10	66 kHz
Gain = 100	39 kHz

Settling time for full-scale step

Gain = 1, 2, 10	50 μ s max to ± 2 LSB
Gain = 100	60 μ s max to ± 2 LSB 50 μ s typ to ± 4 LSB

System noise (including quantization noise)

Gain = 1, 2, 10	1.0 LSB rms
Gain = 100	1.2 LSB rms bipolar, 1.6 LSB rms unipolar

Crosstalk -85 dB max, DC to 20 kHz

Stability

Offset temperature coefficient

Pregain	$\pm 1 \mu\text{V}/^\circ\text{C}$
Postgain	$\pm 120 \mu\text{V}/^\circ\text{C}$

Gain temperature coefficient $\pm 15 \text{ ppm}/^\circ\text{C}$

Digital I/O

Number of channels 8 input/output

Compatibility TTL/CMOS

Digital logic levels

Level	Min	Max
Input low voltage	0 V	0.8 V
Input high voltage	2 V	5 V
Input low current	—	-320 μ A
Input high current	—	10 μ A
Output low voltage ($I_{OL} = 24$ mA)	—	0.4 V
Output high voltage ($I_{OH} = 13$ mA)	4.35 V	—

Power-on state Input (High-Z) pulled up via
100 k Ω

Data transfers Programmed I/O

Timing I/O

Number of channels 2 up/down counter/timers,
1 frequency scaler

Resolution

Counter/timers 24 bits

Frequency scaler 4 bits

Compatibility TTL/CMOS

Base clocks available

Counter/timers 20 MHz, 100 kHz

Frequency scaler 10 MHz, 100 kHz

Base clock accuracy $\pm 0.01\%$

Max source frequency 20 MHz

Min source pulse duration 10 ns, edge-detection mode

Min gate pulse duration	10 ns, edge-detection mode
Data transfers	DMA, interrupts, programmed I/O
DMA modes	Single transfer, demand transfer

Triggers

Digital Trigger

Compatibility	TTL
Response	Rising or falling edge
Pulse width	10 ns min

Calibration

Recommended warm-up time	15 min
Calibration interval	1 year
External calibration reference	>6 and <9.999 V
Onboard calibration reference	
Level	5.000 V (± 2.5 mV) (actual value stored in EEPROM)
Temperature coefficient	± 5 ppm/ $^{\circ}$ C max
Long-term stability	± 15 ppm/ $\sqrt{1,000}$ h

Power Requirement

+5 VDC ($\pm 5\%$)	230 mA active, 90 mA standby
Power available at I/O connector	+4.65 to +5.25 VDC at 250 mA



Note

You can save current by using the NI-DAQ power down utility when your DAQCard is not in use.

Physical

PC Card type Type II
I/O connector..... PCMCIA 68-position female connector

Environment

Operating temperature..... 0° to 55° C
Storage temperature -55° to 150° C
Relative humidity 5% to 90% noncondensing

Optional Cable Connector Descriptions

This appendix describes the connectors on the optional cables for the DAQCard E Series cards.

Figure B-1 shows the pin assignments for the 68-pin AI connector. This connector is available when you use the PSHR68-68M or PR6868 cable assemblies with the DAQCard-AI-16E-4 or DAQCard-AI-16XE-50.

ACH8	34	68	ACH0
ACH1	33	67	AIGND
AIGND	32	66	ACH9
ACH10	31	65	ACH2
ACH3	30	64	AIGND
AIGND	29	63	ACH11
ACH4	28	62	AISENSE
AIGND	27	61	ACH12
ACH13	26	60	ACH5
ACH6	25	59	AIGND
AIGND	24	58	ACH14
ACH15	23	57	ACH7
Reserved	22	56	AIGND
Reserved	21	55	Reserved
Reserved	20	54	Reserved
DIO4	19	53	DGND
DGND	18	52	DIO0
DIO1	17	51	DIO5
DIO6	16	50	DGND
DGND	15	49	DIO2
+5 V	14	48	DIO7
DGND	13	47	DIO3
DGND	12	46	SCANCLK
PFI0/TRIG1	11	45	EXTSTROBE*
PFI1/TRIG2	10	44	DGND
DGND	9	43	PFI2/CONVERT*
+5 V	8	42	PFI3/GPCTR1_SOURCE
DGND	7	41	PFI4/GPCTR1_GATE
PFI5/UPDATE*	6	40	GPCTR1_OUT
PFI6/WFTRIG	5	39	DGND
DGND	4	38	PFI7/STARTSCAN
PFI9/GPCTR0_GATE	3	37	PFI8/GPCTR0_SOURCE
GPCTR0_OUT	2	36	DGND
FREQ_OUT	1	35	DGND

Figure B-1. 68-Pin AI Connector Pin Assignments

Figure B-2 shows the pin assignments for the 50-pin AI connector. This connector is available when you use the SH6850 or R6850 cable assemblies with the PSHR68-68M.

AIGND	1	2	AIGND
ACH0	3	4	ACH8
ACH1	5	6	ACH9
ACH2	7	8	ACH10
ACH3	9	10	ACH11
ACH4	11	12	ACH12
ACH5	13	14	ACH13
ACH6	15	16	ACH14
ACH7	17	18	ACH15
AISENSE	19	20	Reserved
Reserved	21	22	Reserved
Reserved	23	24	DGND
DIO0	25	26	DIO4
DIO1	27	28	DIO5
DIO2	29	30	DIO6
DIO3	31	32	DIO7
DGND	33	34	+5 V
+5 V	35	36	SCANCLK
EXTSTROBE*	37	38	PFI0/TRIG1
PFI1/TRIG2	39	40	PFI2/CONVERT*
PFI3/GPCTR1_SOURCE	41	42	PFI4/GPCTR1_GATE
GPCTR1_OUT	43	44	PFI5/UPDATE*
PFI6/WFTRIG	45	46	PFI7/STARTSCAN
PFI8/GPCTR0_SOURCE	47	48	PFI9/GPCTR0_GATE
GPCTR0_OUT	49	50	FREQ_OUT

Figure B-2. 50-Pin AI Connector Pin Assignments



PC Card Questions and Answers

This appendix contains a list of common questions and answers relating to PC Card (PCMCIA) operation. The questions are grouped according to the type of information requested. You may find this information useful if you are having difficulty with the PCMCIA system software configuration and you are using Windows 3.1.

**Note**

If you are using Windows 95, the operation system will automatically configure your PC Card. All questions in this appendix are specific to Windows 3.1, with the exception of question 3 in the [Operation](#) section.

Configuration

1. Do I need to use my PCMCIA configuration utility to configure the National Instruments PC Cards?

No. We recommend that you do not configure our PC Cards using PC Card Control or an equivalent PC Card configuration utility. Use the configuration utilities included with the NI-DAQ driver software to properly configure your DAQCard. The appropriate utility is the NI-DAQ Configuration Utility (WDAQCONF) for Windows 3.1 users.

2. What should I do if my computer does not have Card and Socket Services version 2.0 or later?

Contact the manufacturer of your computer or of your PCMCIA adapter and request the latest Card and Socket PCMCIA driver. Our NI-DAQ software will work with any Card and Socket Service driver that is compliant to version 2.0 or higher.

Operation

- 1. My PC Card works when inserted before power-on time, but it does not work when hot inserted. What is wrong?**

You may have an interrupt conflict. If you have a utility such as MSD . EXE, run it to determine the allocated interrupts, then refer to question 5 in the [Resources](#) section. MSD . EXE is usually shipped with Microsoft Windows.

- 2. My computer locks up when I use a PC Card. What should I do?**

This usually happens because Card Services allocated an unusable interrupt level to the PC Card. For example, on some computers, interrupt level 11 is not routed to PC Cards. If Card Services is not aware of this, it may assign interrupt 11 to a PC Card even though the interrupt is not usable. When a call uses the interrupt, the interrupt never occurs, and the computer locks up waiting for a response. For information about how to locate an interrupt that is free to be used, refer to question 4 in the [Resources](#) section.

- 3. Is there a way I can conserve power on my PC Card when it is not in use?**

Yes. If you are using NI-DAQ for PC compatibles version 4.8.0 or later, a utility called DAQPOWER . EXE will switch National Instruments PC Cards between normal mode and power-down mode. Run DAQPOWER from the command line to view instructions on the proper usage. Refer to Appendix E, [Power-Management Modes](#), for more information on these modes.

Resources

- 1. How do I determine if I have a memory conflict?**

If no PC Cards are working at all, it is probably because a memory window is not usable. Card Services uses a 4 kB memory window for its own internal use. If the memory cannot be used, then Card Services cannot read the Card Information Structure (CIS) from the DAQCard EPROM, which means it cannot identify cards.

There are two different methods you can use when Card Services has a problem reading the CIS. First, you can determine which memory window Card Services is using, and then exclude that window from use

by Card Services and/or the memory manager. Second, you can attempt to determine all of the memory that Card Services can possibly use and then exclude all but that memory from use by Card Services.

2. How do I determine all of the memory that Card Services can use?

One way to find out which memory addresses Card Services can use is to run a utility such as `MSD.EXE` that scans the system and tells you how the system memory is being used. For example, if you run such a memory utility and it tells you that physical addresses C0000 to C9FFF are being used for ROM access, then you know that C8000–D3FFF is an invalid range for Card Services and should be changed to CA000–D3FFF.

3. How can I find usable I/O addresses?

Identify usable I/O addresses by trial and error. Of the three resources used—memory, I/O, interrupts—I/O conflicts will be low. You can use `WDAQCONF` in Windows to diagnose I/O space conflicts. When you have configured `DAQCONF` or `WDAQCONF` for a particular I/O space, save the configuration. If there is a conflict, the configuration utility will report an error describing the conflict.

4. How do I find usable interrupt levels?

Some utilities, such as `MSD.EXE`, will scan the system and display information about what is using hardware interrupts. If you have such a utility, you can run it to determine what interrupts Card Services can use. Card Services needs an interrupt for itself as well as one interrupt for each PCMCIA socket in the system. For example, in a system with two PCMCIA sockets, at least three interrupts should be allocated for use by Card Services.

Keep in mind that utilities such as `MSD.EXE` will sometimes report that an interrupt is in use when it really is not. For example, if the computer has one serial port, COM1, and one parallel port, LPT1, you know that IRQs 4 and 7 are probably in use. In general, IRQ5 is used for LPT2, but if the computer does not have two parallel ports, IRQ5 should be usable. IRQ3 is used for COM2, but if the computer has only one serial port, IRQ3 should be usable.

5. I run a memory utility, and it appears there is no memory available for Card Services. What should I do?

You should remove your memory manager by commenting it out of the `CONFIG.SYS` file. Next, you can rerun the memory utility. Memory managers often consume an enormous amount of memory, and you will need to determine what memory is really usable by Card Services. When you have determined what memory is available for Card Services, reinstall your memory manager and make the necessary changes to provide Card Services with the memory needed. We suggest that you use the minimum amount of memory for Card Services, namely 4 to 12 kB, which frees more memory for the memory manager.

Resource Conflicts

1. How do I resolve conflicts between my memory manager and Card Services?

Card Services can usually use memory space that is not being used for real RAM on the system. Even when this is the case, you should still exclude the memory addresses used by Card Services from use by any memory manager that may be installed.

Common Questions

This appendix contains a list of commonly asked questions and their answers relating to usage and special features of your DAQCard E Series card.

General Information

1. What are the DAQCard E Series cards?

The DAQCard E Series cards are switchless and jumperless, enhanced DAQCards that use the DAQ-STC for timing.

2. What is the DAQ-STC?

The DAQ-STC is the system timing control ASIC (application-specific integrated circuit) designed by National Instruments and is the backbone of the DAQCard E Series cards. The DAQ-STC contains seven 24-bit counters and three 16-bit counters. The counters are divided into three groups:

Analog input—two 24-bit, two 16-bit counters

Analog output—three 24-bit, one 16-bit counters

General-purpose counter/timer functions—two 24-bit counters

The groups can be configured independently with timing resolutions of 50 ns or 10 μ s. With the DAQ-STC, you can interconnect a wide variety of internal timing signals to other internal blocks. The interconnection scheme is quite flexible and completely software configurable. New capabilities such as buffered pulse generation, equivalent time sampling, and seamlessly changing the sampling rate are possible.

3. How fast is each DAQCard E Series card?

The last numeral in the name of a DAQCard specifies the settling time in microseconds for that particular DAQCard. For example, the DAQCard-AI-16E-4 has a 4 μ s settling time, which corresponds to a sampling rate of 250 kS/s. These sampling rates are aggregate: one channel at 250 kS/s or two channels at 125 kS/s per channel illustrates the relationship. Notice, however, that some DAQCard E Series cards have settling times that vary with gain and accuracy. See Appendix A, *Specifications*, for exact specifications.

4. What type of 5 V protection do the DAQCard E Series cards have?

The DAQCard E Series cards have 5 V lines equipped with a self-resetting 250 mA fuse.

Installation and Configuration

1. Which National Instruments documentation should I read first to get started using DAQ software?

Refer to the *Configuration* section in Chapter 2 of this manual, *Installation and Configuration*, for this information.

2. What version of NI-DAQ must I have to program my DAQCard E Series card?

You must have version 4.9.0 or higher for the DAQCard-AI-16E-4 and DAQCard-AI-16XE-50, and version 4.6.1 or higher for all other DAQCard E Series cards.

3. What is the best way to test my DAQCard without having to program the DAQCard?

If you are using Windows, the NI-DAQ Configuration Utility (formerly `WDAQCONF`) has a **Test** menu with some excellent tools for doing simple functional tests of the DAQCard, such as analog input and output, digital I/O, and counter/timer tests.

4. How can I select a DAQCard E Series card as my device type in the NI-DAQ Configuration Utility?

First, make sure your DAQCard is plugged into your computer. The NI-DAQ Configuration Utility scans your system for any DAQCard E Series cards. If no DAQCard E Series cards are found, the DAQCard E Series card types are not given as choices.

Analog Input and Output

1. **I'm using my DAQCard in differential analog input mode and I have connected a differential input signal, but my readings are random and drift rapidly. What's wrong?**

Check your ground reference connections. Your signal may be referenced to a level that is considered *floating* with reference to the DAQCard ground reference. Even if you are in differential mode, the signal *must* still be referenced to the same ground level as the DAQCard reference. There are various methods of achieving this while maintaining a high common-mode rejection ratio (CMRR). These methods are outlined in Chapter 4, [Signal Connections](#).

2. **Can I sample across a number of channels on a DAQCard E Series card while each channel is being sampled at a different rate?**

NI-DAQ features a function called `SCAN_Sequence_Setup`, which allows for multirate scanning of your analog input channels. Refer to the *NI-DAQ Function Reference Manual for PC Compatibles* for more details.

Timing and Digital I/O

1. **What types of triggering can be implemented in hardware on my DAQCard E Series card?**

Digital triggering is supported by hardware on every DAQCard E Series card. In addition, the DAQCard-AI-16E-4 supports analog triggering with its hardware.

2. **What added functionality does the DAQ-STC make possible in contrast to the Am9513?**

The DAQ-STC incorporates much more than just 10 Am9513-style counters within one chip. In fact, the DAQ-STC has the complexity of more than 24 chips. The DAQ-STC makes possible PFI lines, analog triggering, selectable logic level, and frequency shift keying. The DAQ-STC also makes buffered operations possible, such as direct up/down control, single or pulse train generation, equivalent time sampling, buffered period, and buffered semiperiod measurement.

3. What is the difference in timebases between the Am9513 counter/timer and the DAQ-STC?

The DAQ-STC-based boards have a 20 MHz timebase. The Am9513-based boards have a 1 or 5 MHz timebase.

4. The counter/timer examples supplied with NI-DAQ are not compatible with an DAQCard E Series card. Where can I find examples to illustrate the use of the DAQ-STC as a general-purpose counter/timer?

If you are using the NI-DAQ language interface and a C compiler under DOS, a new subdirectory called GPCTR, which lies beneath the examples directory, contains 16 examples of the most common uses of the DAQ-STC.

5. Will the counter/timer applications that I wrote previously work with the DAQ-STC?

If you are using the NI-DAQ with LabVIEW, some of your applications drawn using the CTR VIs will still run. However, there are many differences in the counters between the DAQCard E Series and other boards; the counter numbers are different, timebase selections are different, the DAQ-STC counters are 24-bit counters (unlike the 16-bit counters on boards without the DAQ-STC).

If you are using the NI-DAQ language interface, such as LabWindows/CVI, the answer is, no, the counter/time applications that you wrote previously will not work with the DAQ-STC. You must use the GPCTR functions; ICTR and CTR functions will not work with the DAQ-STC. The GPCTR functions have the same capabilities as the ICTR and CTR functions, plus more, but you must rewrite the application with the GPCTR function calls.

6. I'm using one of the general-purpose counter/timers on my DAQCard E Series card, but I do not see the counter/timer output on the I/O connector. What am I doing wrong?

If you are using NI-DAQ language interface or LabWindows/CVI, you must configure the output line to output the signal to the I/O connector. Use the `Select_Signal` call in NI-DAQ to configure the output line. By default, all timing I/O lines except EXTSTROBE* are tri-stated.

7. What are the PFIs and how do I configure these lines?

PFIs are Programmable Function Inputs. These lines serve as connections to virtually all internal timing signals.

If you are using NI-DAQ language interface, LabWindows, or LabWindows/CVI, use the `Select_Signal` function to route internal signals to the I/O connector, route external signals to internal timing sources, or tie internal timing signals together.

If you are using NI-DAQ with LabVIEW and you want to connect external signal sources to the PFI lines, you can use AI Clock Config, AI Trigger Config, AO Clock Config, AO Trigger and Gate Config, CTR Mode Config, and CTR Pulse Config advanced level VIs to indicate which function the connected signal will serve. Use the Route Signal VI to enable the PFI lines to output internal signals.



Warning *If you enable a PFI line for output, do not connect any external signal source to it; if you do, you can damage the DAQCard, the computer, and the connected equipment.*

Power-Management Modes

This appendix describes the power-management modes of the DAQCard E Series cards.

- Normal Mode—This is the normal operating mode of the DAQCard E Series cards in which all the circuits are fully functional. See the specifications for each DAQCard in Appendix A, *Specifications*, for power consumption in the normal mode. The DAQCard is automatically configured for normal mode upon insertion.
- Power-Down Mode—In this mode, the digital circuitry is powered on and is functional. The analog input circuit is powered down by setting the PWRDOWN bit in the PCMCIA Card Configuration and Status Register. You can set the PWRDOWN bit by using the DAQPOWER utility that is shipped with NI-DAQ. Use DAQPOWER-D to power down and DAQPOWER-U to power up the DAQCard E Series cards. Power-down mode is specified to draw less than 100 mA from the 5 V supply (500 mW). See the power consumption specifications in Appendix A, *Specifications*, for exact values. The DAQCard is automatically configured for normal mode upon insertion.

**Note**

National Instruments strongly recommends that you power down your DAQCard when you are not actively using it. Doing so will greatly extend your computer's battery life.

Table E-1 shows the effects of different power-management modes on the DAQCard E Series circuits.

Table E-1. DAQCard E Series Power-Management Modes

	Normal Mode	Power-Down Mode
Analog Input	Functional. Protected to ± 25 V. Impedance > 1 G Ω .	Nonfunctional. Draws negligible power. Protected to ± 10 V. Impedance = 1.0 k Ω , which is the input protection resistance.
Calibration Circuitry	Functional. Both analog input and analog output can be fully calibrated.	Partially functional. Draws negligible power. CALDACs retain values and may be loaded, but adjustments will not be detected in analog circuitry, which is powered off.
Digital I/O	Functional. Protected from -0.5 to 5.5 V.	Functional. Protected from -0.5 to 5.5 V.
Counters	Functional. Initialize to undefined states. Individual counters of the DAQ-STC must be fully programmed before use. Protected from -0.5 to 5.5 V.	Functional. Initialize to undefined states. Individual counters of the DAQ-STC must be fully programmed before use. Protected from -0.5 to 5.5 V.

Customer Communication

For your convenience, this appendix contains forms to help you gather the information necessary to help us solve your technical problems and a form you can use to comment on the product documentation. When you contact us, we need the information on the Technical Support Form and the configuration form, if your manual contains one, about your system configuration to answer your questions as quickly as possible.

National Instruments has technical assistance through electronic, fax, and telephone systems to quickly provide the information you need. Our electronic services include a bulletin board service, an FTP site, a fax-on-demand system, and e-mail support. If you have a hardware or software problem, first try the electronic support systems. If the information available on these systems does not answer your questions, we offer fax and telephone support through our technical support centers, which are staffed by applications engineers.

Electronic Services

Bulletin Board Support

National Instruments has BBS and FTP sites dedicated for 24-hour support with a collection of files and documents to answer most common customer questions. From these sites, you can also download the latest instrument drivers, updates, and example programs. For recorded instructions on how to use the bulletin board and FTP services and for BBS automated information, call 512 795 6990. You can access these services at:

United States: 512 794 5422

Up to 14,400 baud, 8 data bits, 1 stop bit, no parity

United Kingdom: 01635 551422

Up to 9,600 baud, 8 data bits, 1 stop bit, no parity

France: 01 48 65 15 59

Up to 9,600 baud, 8 data bits, 1 stop bit, no parity

FTP Support

To access our FTP site, log on to our Internet host, `ftp.natinst.com`, as `anonymous` and use your Internet address, such as `joesmith@anywhere.com`, as your password. The support files and documents are located in the `/support` directories.

Fax-on-Demand Support

Fax-on-Demand is a 24-hour information retrieval system containing a library of documents on a wide range of technical information. You can access Fax-on-Demand from a touch-tone telephone at 512 418 1111.

E-Mail Support (Currently USA Only)

You can submit technical support questions to the applications engineering team through e-mail at the Internet address listed below. Remember to include your name, address, and phone number so we can contact you with solutions and suggestions.

support@natinst.com

Telephone and Fax Support

National Instruments has branch offices all over the world. Use the list below to find the technical support number for your country. If there is no National Instruments office in your country, contact the source from which you purchased your software to obtain support.

Country	Telephone	Fax
Australia	03 9879 5166	03 9879 6277
Austria	0662 45 79 90 0	0662 45 79 90 19
Belgium	02 757 00 20	02 757 03 11
Brazil	011 288 3336	011 288 8528
Canada (Ontario)	905 785 0085	905 785 0086
Canada (Québec)	514 694 8521	514 694 4399
Denmark	45 76 26 00	45 76 26 02
Finland	09 725 725 11	09 725 725 55
France	01 48 14 24 24	01 48 14 24 14
Germany	089 741 31 30	089 714 60 35
Hong Kong	2645 3186	2686 8505
Israel	03 6120092	03 6120095
Italy	02 413091	02 41309215
Japan	03 5472 2970	03 5472 2977
Korea	02 596 7456	02 596 7455
Mexico	5 520 2635	5 520 3282
Netherlands	0348 433466	0348 430673
Norway	32 84 84 00	32 84 86 00
Singapore	2265886	2265887
Spain	91 640 0085	91 640 0533
Sweden	08 730 49 70	08 730 43 70
Switzerland	056 200 51 51	056 200 51 55
Taiwan	02 377 1200	02 737 4644
United Kingdom	01635 523545	01635 523154
United States	512 795 8248	512 794 5678

Technical Support Form

Photocopy this form and update it each time you make changes to your software or hardware, and use the completed copy of this form as a reference for your current configuration. Completing this form accurately before contacting National Instruments for technical support helps our applications engineers answer your questions more efficiently.

If you are using any National Instruments hardware or software products related to this problem, include the configuration forms from their user manuals. Include additional pages if necessary.

Name _____

Company _____

Address _____

Fax (____) _____ Phone (____) _____

Computer brand _____ Model _____ Processor _____

Operating system (include version number) _____

Clock speed _____ MHz RAM _____ MB Display adapter _____

Mouse ___ yes ___ no Other adapters installed _____

Hard disk capacity _____ MB Brand _____

Instruments used _____

National Instruments hardware product model _____ Revision _____

Configuration _____

National Instruments software product _____ Version _____

Configuration _____

The problem is: _____

List any error messages: _____

The following steps reproduce the problem: _____

DAQCard E Series Hardware and Software Configuration Form

Record the settings and revisions of your hardware and software on the line to the right of each item. Complete a new copy of this form each time you revise your software or hardware configuration, and use this form as a reference for your current configuration. Completing this form accurately before contacting National Instruments for technical support helps our applications engineers answer your questions more efficiently.

National Instruments Products

DAQCard E Series card _____

DAQCard E Series card serial number _____

Interrupt level of DAQCard E Series card _____

DMA channels of DAQCard E Series card _____

Base I/O address of DAQCard E Series card _____

Programming choice (NI-DAQ, LabVIEW, LabWindows/CVI, or other) _____

Software version _____

Other Products

Computer model _____

Microprocessor _____

Clock frequency _____

Type of video board installed _____

Operating system version _____

Operating system mode _____

Programming language _____

Programming language version _____

Other boards in system _____

Base I/O address of other boards _____

DMA channels of other boards _____

Interrupt level of other boards _____

Documentation Comment Form

National Instruments encourages you to comment on the documentation supplied with our products. This information helps us provide quality products to meet your needs.

Title: *DAQCard E Series User Manual*

Edition Date: March 1999

Part Number: 321138C-01

Please comment on the completeness, clarity, and organization of the manual.

If you find errors in the manual, please record the page numbers and describe the errors.

Thank you for your help.

Name _____

Title _____

Company _____

Address _____

E-Mail Address _____

Phone (___) _____ Fax (___) _____

Mail to: Technical Publications
National Instruments Corporation
6504 Bridge Point Parkway
Austin, Texas 78730-5039

Fax to: Technical Publications
National Instruments Corporation
512 794 5678

Glossary

Prefix	Meanings	Value
p-	pico	10^{-12}
n-	nano-	10^{-9}
μ -	micro-	10^{-6}
m-	milli-	10^{-3}
k-	kilo-	10^3
M-	mega-	10^6
G-	giga-	10^9

Symbols

°	degrees
-	negative of, or minus
Ω	ohms
/	per
%	percent
\pm	plus or minus
+	positive of, or plus
$\sqrt{\quad}$	square root of
+5 V	+5 VDC source signal

A

A	amperes
AC	alternating current
ACH	analog input channel signal
A/D	analog-to-digital
ADC	A/D converter
ADIO	analog/digital input/output
AI	analog input
AIGATE	analog input gate signal
AIGND	analog input ground signal
AISENSE	analog input sense signal
AOGND	analog output ground signal
ASIC	application-specific integrated circuit

B

BBS	bulletin board support
BIOS	basic input/output system or built-in operating system

C

C	Celsius
CalDAC	calibration DAC
CH	channel
CIS	Card Information Structure
cm	centimeter

CMOS	complementary metal-oxide semiconductor
CMRR	common-mode rejection ratio
CONVERT*	convert signal
CTR	counter

D

D/A	digital-to-analog
DAC	D/A converter
DAC0OUT	analog channel 0 output signal
DAC1OUT	analog channel 1 output signal
DAQ	data acquisition
DAQCard	data acquisition card
dB	decibels
DC	direct current
DGND	digital ground signal
DIFF	differential
DIO	digital input/output
DMA	direct memory access
DNL	differential nonlinearity
DO	digital output
DOS	disk operating system

E

EEPROM	electrically erasable programmable read-only memory
EISA	Extended Industry Standard Architecture
EPROM	erasable programmable read-only memory
EXTREF	external reference signal
EXTSTROBE	external strobe signal

F

F	farads
FIFO	first-in-first-out
FREQ_OUT	frequency output signal
ft	feet

G

GPCTR0_GATE	general purpose counter 0 gate signal
GPCTR1_GATE	general purpose counter 1 gate signal
GPCTR0_OUT	general purpose counter 0 output signal
GPCTR1_OUT	general purpose counter 1 output signal
GPCTR0_SOURCE	general purpose counter 0 clock source signal
GPCTR1_SOURCE	general purpose counter 1 clock source signal
GPTR0_UP_DOWN	general purpose counter 0 up down signal
GPTR1_UP_DOWN	general purpose counter 1 up down signal

H

h	hour
hex	hexadecimal
Hz	hertz

I

ICTR	input counter
I/O	input/output
I_{OH}	current, output high
I_{OL}	current, output low
IRQ	interrupt request signal
ISA	Industry Standard Architecture

L

LED	light emitting diode
LSB	least significant bit

M

m	meter
MB	megabytes of memory
MSB	most significant bit

N

NC	not connected internally
NRSE	nonreferenced single-ended

O

OUT output signal

P

PC personal computer

PCMCIA Personal Computer Memory Card Association

PFI Programmable Function Input

PGIA Programmable Gain Instrumentation Amplifier

ppm parts per million

pu pullup

PWRDOWN power down signal

R

RAM random access memory

REF reference

rms root mean square

RSE referenced single-ended

RTD resistive temperature device

S

s seconds

S samples

SCANCLK scan clock signal

SCXI Signal Conditioning eXtensions for Instrumentation

SE	single-ended inputs
SISOURCE	SI counter clock signal
STARTSCAN	start scan signal
T	
TC	terminal count signal
t_{gh}	gate hold time
t_{gsu}	gate setup time
t_{gw}	gate pulse width
THD	total harmonic distortion
t_{out}	output delay time
TRIG	trigger signal
t_{sc}	source clock period
t_{sp}	source pulse width
TTL	transistor-transistor logic
U	
UI	update interval
UISOURCE	update interval counter clock signal
UPDATE*	update signal
V	
V	volts
VCC	positive voltage supply
VDC	volts direct current

Glossary

VI virtual instrument

V_{IH} volts, input high

V_{IL} volts, input low

V_{in} volts in

V_o volts, output

V_{OH} volts, output high

V_{OL} volts, output low

V_{ref} reference voltage

W

W watts

WFTRIG waveform generation trigger signal

Index

Numbers

- +5 V signal
 - description, 4-3
 - power connections, 4-22

A

- ACH<0..15> signal
 - analog input connections, 4-10
 - DAQCard-AI-16E-4 (table), 4-5
 - DAQCard-AI-16XE-50 (table), 4-8
 - description, 4-3
- AIGATE signal, 4-34 to 4-35
- AIGND signal
 - analog input connections, 4-10 to 4-11
 - DAQCard-AI-16E-4 (table), 4-5
 - DAQCard-AI-16XE-50 (table), 4-8
 - description, 4-3
 - differential connections for floating signal sources, 4-16 to 4-17
- AISENSE signal
 - analog input connections, 4-10
 - DAQCard-AI-16E-4 (table), 4-5
 - DAQCard-AI-16XE-50 (table), 4-8
 - description, 4-3
- amplifier characteristic specifications
 - DAQCard-AI-16E-4, A-3
 - DAQCard-AI-16XE-50, A-9
- analog input, 3-2 to 3-8
 - dither, 3-6 to 3-7
 - input mode, 3-2 to 3-3
 - input polarity and range, 3-3 to 3-5
 - DAQCard-AI-16E-4, 3-3 to 3-4
 - DAQCard-AI-16XE-50, 3-4 to 3-5
 - multichannel scanning considerations, 3-7 to 3-8
 - power-management modes (table), E-2
 - questions about, D-3
 - selection considerations, 3-6 to 3-7
 - signal connections, 4-10 to 4-11

- analog input specifications
 - DAQCard-AI-16E-4, A-1 to A-4
 - amplifier characteristics, A-3
 - dynamic characteristics, A-3 to A-4
 - input characteristics, A-1 to A-2
 - stability, A-4
 - transfer characteristics, A-3
 - DAQCard-AI-16XE-50, A-8 to A-10
 - amplifier characteristics, A-9 to A-10
 - dynamic characteristics, A-10
 - input characteristics, A-8 to A-9
 - stability, A-10
 - transfer characteristics, A-9
- analog trigger, 3-9 to 3-12
 - above-high-level triggering mode (figure), 3-10
 - below-low-level triggering mode (figure), 3-10
 - block diagram, 3-9
 - high-hysteresis triggering mode, 3-11
 - inside-region triggering mode (figure), 3-11
 - low-hysteresis triggering mode, 3-12

B

- bipolar input
 - DAQCard-AI-16E-4, 3-3
 - DAQCard-AI-16XE-50, 3-4 to 3-5
 - mixing bipolar and unipolar channels (note), 3-5

block diagrams

DAQCard-AI-16E-4, 3-1

DAQCard-AI-16XE-50, 3-2

bulletin board support, F-1

Ccables. *See also I/O connectors.*

custom cabling, 1-5 to 1-6

field wiring considerations, 4-44

optional equipment, 1-5

part numbers for connectors, 1-6

calibration, 5-1 to 5-3

adjusting for gain error, 5-3

DAQCard-AI-16E-4, A-6 to A-7

DAQCard-AI-16XE-50, A-12

external calibration, 5-2 to 5-3

loading calibration constants, 5-1 to 5-2

mixing unipolar and bipolar channels

(note), 3-5

power-management modes (table), E-2

self-calibration, 5-2

Card and Socket Services, C-1

charge injection, 3-8

clocks, DAQCard, 3-14

commonly asked questions. *See questions and answers.*

common-mode signal rejection, 4-20

configuration. *See also input configurations.*

questions about, D-2

software configuration, 2-2 to 2-3

connectors. *See I/O connectors.*

CONVERT* signal

signal routing, 3-13

multiplexer for controlling

(figure), 3-13

timing connections, 4-33 to 4-34

input timing (figure), 4-33

output timing (figure), 4-34

counter power-management modes

(table), E-2

current, saving, A-12, C-2

customer communication, *xiv*, F-1 to F-2**D**

DAQCard clocks, 3-14

DAQCard E Series. *See also hardware overview.*

custom cabling, 1-5 to 1-6

features, 1-1

getting started, 1-2

optional equipment, 1-5 to 1-6

questions about, D-1 to D-5

software programming choices

LabVIEW and LabWindows/CVI

application software, 1-2 to 1-3

NI-DAQ driver software, 1-3 to 1-4

register-level programming, 1-4

unpacking, 1-6

DAQ-STC system timing controller, 1-1, D-1

data acquisition timing connections,
4-24 to 4-36

AIGATE signal, 4-34 to 4-35

CONVERT* signal, 4-33 to 4-34

EXTSTROBE* signal, 4-27

SCANCLK signal, 4-26

SISOURCE signal, 4-35

STARTSCAN signal, 4-30 to 4-33

TRIG1 signal, 4-27 to 4-28

TRIG2 signal, 4-29 to 4-30

typical posttriggered acquisition
(figure), 4-25typical pretriggered acquisition
(figure), 4-25

UISOURCE signal, 4-36

DGND signal

DAQCard-AI-16E-4 (table), 4-6

DAQCard-AI-16XE-50 (table), 4-8

description, 4-3

digital I/O connections, 4-21

timing I/O connections, 4-23

DIFF (differential) input mode

definition (table), 3-3

description, 4-14

- ground-referenced signal sources, 4-15
 - illustration, 4-15
- nonreferenced or floating signal sources, 4-16 to 4-17
 - illustration, 4-16
- recommended configuration (figure), 4-13
- single-ended connections, 4-18
 - floating signal sources (RSE), 4-19
 - grounded signal sources (NRSE), 4-19 to 4-20
 - when to use, 4-14
- differential input mode, questions about, D-3
- digital I/O
 - operation, 3-12
 - power-management modes (table), E-2
 - questions about, D-3 to D-5
 - signal connections, 4-21 to 4-22
 - specifications
 - DAQCard-AI-16E-4, A-5
 - DAQCard-AI-16XE-50, A-11
- DIO<0..7> signal
 - DAQCard-AI-16E-4 (table), 4-6
 - DAQCard-AI-16XE-50 (table), 4-8
 - description, 4-3
 - digital I/O connections, 4-21 to 4-22
- dither
 - enabling, 3-6 to 3-7
 - signal acquisition effects (figure), 3-7
- documentation
 - conventions used in manual, *xii-xiii*
 - National Instruments documentation, *xiii-xiv*
 - organization of manual, *xi-xii*
 - related documentation, *xiv*
- dynamic characteristic specifications
 - DAQCard-AI-16E-4, A-3 to A-4
 - DAQCard-AI-16XE-50, A-10

E

- EEPROM storage of calibration constants, 5-1
- electronic support services, F-1 to F-2
- e-mail support, F-2
- environment specifications
 - DAQCard-AI-16E-4, A-7
 - DAQCard-AI-16XE-50, A-13
- environmental noise, avoiding, 4-44
- equipment, optional, 1-5 to 1-6
- EXTSTROBE* signal
 - DAQCard-AI-16E-4 (table), 4-6
 - DAQCard-AI-16XE-50 (table), 4-8
 - description, 4-3
 - timing connections, 4-27
 - illustration, 4-27

F

- fax and telephone support, F-2
- FaxBack support, F-2
- field wiring considerations, 4-44
- floating signal sources
 - description, 4-12
 - differential connections, 4-16 to 4-17
 - recommended configuration (figure), 4-13
 - single-ended connections (RSE configuration), 4-19
- FREQ_OUT signal
 - DAQCard-AI-16E-4 (table), 4-7
 - DAQCard-AI-16XE-50 (table), 4-9
 - description, 4-5
 - general-purpose timing connections, 4-43
- frequently asked questions. *See questions and answers.*
- FTP support, F-1

G

- general-purpose timing signal connections, 4-37 to 4-43
 - FREQ_OUT signal, 4-43
 - GPCTR0_GATE signal, 4-38
 - GPCTR0_OUT signal, 4-38 to 4-39
 - GPCTR0_SOURCE signal, 4-37 to 4-38
 - GPCTR0_UP_DOWN signal, 4-39
 - GPCTR1_GATE signal, 4-40 to 4-41
 - GPCTR1_OUT signal, 4-41
 - GPCTR1_SOURCE signal, 4-39 to 4-40
 - GPCTR1_UP_DOWN signal, 4-42 to 4-43
 - questions about, D-4
- GPCTR0_GATE signal, 4-38
- GPCTR0_OUT signal
 - DAQCard-AI-16E-4 (table), 4-6
 - DAQCard-AI-16XE-50 (table), 4-9
 - description, 4-5
 - general-purpose timing connections, 4-38 to 4-39
- GPCTR0_SOURCE signal, 4-37 to 4-38
- GPCTR0_UP_DOWN signal, 4-39
- GPCTR1_GATE signal, 4-40 to 4-41
- GPCTR1_OUT signal
 - DAQCard-AI-16E-4 (table), 4-6
 - DAQCard-AI-16XE-50 (table), 4-8
 - description, 4-4
 - general-purpose timing connections, 4-41
- GPCTR1_SOURCE signal, 4-39 to 4-40
- GPCTR1_UP_DOWN signal, 4-42 to 4-43
- ground-referenced signal sources
 - description, 4-12
 - differential connections, 4-15
 - recommended configuration (figure), 4-13
 - single-ended connections (NRSE configuration), 4-19 to 4-20

H

- hardware installation, 2-1
- hardware overview
 - analog input, 3-2 to 3-8
 - dither, 3-6 to 3-7
 - input mode, 3-2 to 3-3
 - input polarity and range, 3-3 to 3-5
 - multichannel scanning
 - considerations, 3-7 to 3-8
 - selection considerations, 3-6 to 3-7
 - analog trigger, 3-9 to 3-12
 - above-high-level triggering mode (figure), 3-10
 - below-low-level triggering mode (figure), 3-10
 - block diagram, 3-9
 - high-hysteresis triggering mode, 3-11
 - inside-region triggering mode (figure), 3-11
 - low-hysteresis triggering mode, 3-12
 - block diagrams
 - DAQCard-AI-16E-4, 3-1
 - DAQCard-AI-16XE-50, 3-2
 - digital I/O, 3-12
 - timing signal routing, 3-13 to 3-14
 - DAQCard clocks, 3-14
 - programmable function inputs, 3-14

I

- input characteristic specifications
 - DAQCard-AI-16E-4, A-1 to A-2
 - DAQCard-AI-16XE-50, A-8 to A-9
- input configurations, 4-12 to 4-20
 - available input modes, 3-2 to 3-3
 - DIFF (table), 3-3
 - NRSE (table), 3-3
 - RSE (table), 3-3
 - common-mode signal rejection, 4-20

- differential connections
 - DIFF input configuration, 4-14
 - floating signal sources, 4-16 to 4-17
 - ground-referenced signal sources, 4-15
 - nonreferenced signal sources, 4-16 to 4-17
- recommended configuration (figure), 4-13
- single-ended connections, 4-18 to 4-20
 - floating signal sources (RSE configuration), 4-19
 - grounded signal sources (NRSE configuration), 4-19 to 4-20
- input polarity and range, 3-3 to 3-5
 - DAQCard-AI-16E-4
 - actual range and measurement precision (table), 3-4
 - unipolar and bipolar, 3-3 to 3-4
 - DAQCard-AI-16XE-50
 - actual range and measurement precision (table), 3-5
 - unipolar and bipolar, 3-3 to 3-5
- dither, 3-6 to 3-7
- mixing bipolar and unipolar channels (note), 3-5
- selection considerations, 3-6 to 3-7
- installation
 - hardware, 2-1
 - questions about, D-2
 - software, 2-2 to 2-3
 - typical configuration (figure), 2-2
 - unpacking DAQCard E Series, 1-6
- I/O connectors, 4-1 to 4-9
 - cable connectors for DAQCard E Series, 1-6
 - exceeding maximum ratings (warning), 4-1
 - I/O signal summary (table)
 - DAQCard-AI-16E-4, 4-5 to 4-7
 - DAQCard-AI-16XE-50, 4-8 to 4-9

- pin assignments (figure)
 - 50-pin AI connector, B-3
 - 68-pin AI connector, B-2
 - DAQCard-AI-16E-4 and DAQCard-AI-16XE-50 (figure), 4-2
- signal descriptions (table), 4-3 to 4-5

L

- LabVIEW and LabWindows/CVI application software, 1-2 to 1-3

M

- manual. *See documentation.*
- memory conflict, C-2, C-4
- multichannel scanning, 3-7 to 3-8

N

- NI-DAQ driver software, 1-3 to 1-4
 - power-down utility, A-12
- noise, avoiding, 4-44
- NRSE (nonreferenced single-ended input)
 - description (table), 3-3
 - differential connections, 4-16 to 4-17
 - recommended configuration (figure), 4-13
 - single-ended connections (NRSE configuration), 4-19 to 4-20

O

- optional equipment, 1-5 to 1-6

P

- PC (PCMCIA) Card questions and answers, C-1 to C-4
 - configuration, C-1
 - operation, C-2
 - resource conflicts, C-4
 - resources, C-2 to C-4

- PFI0/TRIG1 signal
 - DAQCard-AI-16E-4 (table), 4-6
 - DAQCard-AI-16XE-50 (table), 4-8
 - description, 4-3
- PFI1/TRIG2 signal
 - DAQCard-AI-16E-4 (table), 4-6
 - DAQCard-AI-16XE-50 (table), 4-8
 - description, 4-4
- PFI2/CONVERT* signal
 - DAQCard-AI-16E-4 (table), 4-6
 - DAQCard-AI-16XE-50 (table), 4-8
 - description, 4-4
- PFI3/GPCTR1_SOURCE signal
 - DAQCard-AI-16E-4 (table), 4-6
 - DAQCard-AI-16XE-50 (table), 4-8
 - description, 4-4
- PFI4/GPCTR1_GATE signal
 - DAQCard-AI-16E-4 (table), 4-6
 - DAQCard-AI-16XE-50 (table), 4-8
 - description, 4-4
- PFI5/UPDATE* signal
 - DAQCard-AI-16E-4 (table), 4-6
 - DAQCard-AI-16XE-50 (table), 4-8
 - description, 4-4
- PFI6/WFTRIG signal
 - DAQCard-AI-16E-4 (table), 4-6
 - DAQCard-AI-16XE-50 (table), 4-8
 - description, 4-4
- PFI7/STARTSCAN signal
 - DAQCard-AI-16E-4 (table), 4-6
 - DAQCard-AI-16XE-50 (table), 4-8
 - description, 4-5
- PFI8/GPCTR0_SOURCE signal
 - DAQCard-AI-16E-4 (table), 4-6
 - DAQCard-AI-16XE-50 (table), 4-8
 - description, 4-5
- PFI9/GPCTR0_GATE signal
 - DAQCard-AI-16E-4 (table), 4-6
 - DAQCard-AI-16XE-50 (table), 4-9
 - description, 4-5
- PFI (programmable function inputs), 4-24
 - connecting to external signal source (warning), D-5
 - overview, 4-22
 - questions about, D-5
 - signal routing, 3-14
 - timing input connections, 4-24
 - illustration, 4-23
- PGIA (programmable gain instrumentation amplifier)
 - analog input connections, 4-11
 - illustration, 4-11
 - common-mode signal rejection, 4-20
 - differential connections
 - floating signal sources, 4-16 to 4-17
 - ground-referenced signal sources, 4-15
 - single-ended connections
 - floating signal sources (figure), 4-19
 - grounded signal sources (figure), 4-20
- physical specifications
 - DAQCard-AI-16E-4, A-7
 - DAQCard-AI-16XE-50, A-12
- pin assignments
 - 50-pin AI connector, B-3
 - 68-pin AI connector, B-2
 - DAQCard-AI-16E-4 and DAQCard-AI-16XE-50 (figure), 4-2
- polarity. *See input polarity and range.*
- posttriggered data acquisition, 4-24
 - illustration, 4-25
- power connections, 4-22
- power requirement specifications
 - DAQCard-AI-16E-4, A-6 to A-7
 - DAQCard-AI-16XE-50, A-12
- power-management modes, E-1 to E-2
 - effects of different modes (table), E-2
 - Normal mode, E-1
 - Power-down Mode, E-1
- pretriggered data acquisition, 4-24
 - illustration, 4-25

programmable function inputs (PFIs). *See* *PFIs (programmable function inputs)*.
 programmable gain instrumentation amplifier.
See *PGIA (programmable gain instrumentation amplifier)*.

Q

questions and answers

- DAQCard E Series questions
 - analog input and output, D-3
 - general information, D-1 to D-2
 - installation and configuration, D-2
 - timing and digital I/O, D-3 to D-5
- PC (PCMCIA) Cards, C-1 to C-4
 - configuration, C-1
 - operation, C-2
 - resource conflicts, C-4
 - resources, C-2 to C-4

R

referenced single-ended input (RSE). *See* *RSE (referenced single-ended input)*.
 register-level programming, 1-4
 RSE (referenced single-ended input)

- description (table), 3-3
- recommended configuration (figure), 4-13
- single-ended connections for floating signal sources, 4-19

S

SCANCLK signal

- DAQCard-AI-16E-4 (table), 4-6
- DAQCard-AI-16XE-50 (table), 4-8
- description, 4-3
- timing connections, 4-26
 - illustration, 4-26

 settling time, 3-7 to 3-8

signal connections

- analog input, 4-10 to 4-11
- digital I/O, 4-21 to 4-22
- field wiring considerations, 4-44
- input configurations, 4-12 to 4-20
 - common-mode signal rejection, 4-20
 - differential connections
 - DIFF input configuration, 4-14
 - floating signal sources, 4-16 to 4-17
 - ground-referenced signal sources, 4-15
 - nonreferenced signal sources, 4-16 to 4-17
 - recommended configuration (figure), 4-13
 - single-ended connections, 4-18 to 4-20
 - floating signal sources (RSE configuration), 4-19
 - grounded signal sources (NRSE configuration), 4-19 to 4-20
- I/O connector, 4-1 to 4-9
 - exceeding maximum ratings (warning), 4-1
 - I/O signal summary (table)
 - DAQCard-AI-16E-4, 4-5 to 4-7
 - DAQCard-AI-16XE-50, 4-8 to 4-9
 - pin assignments (figure)
 - 50-pin AI connector, B-3
 - 68-pin AI connector, B-2
 - DAQCard-AI-16E-4 and DAQCard-AI-16XE-50, 4-2
 - signal descriptions (table), 4-3 to 4-5
- power connections, 4-22
- timing connections, 4-22 to 4-43
 - data acquisition timing connections, 4-24 to 4-36
 - AIGATE signal, 4-34 to 4-35
 - CONVERT* signal, 4-33 to 4-34
 - EXTSTROBE* signal, 4-27
 - SCANCLK signal, 4-26

- SISOURCE signal, 4-35
- STARTSCAN signal, 4-30
 - to 4-33
- TRIG1 signal, 4-27 to 4-28
- TRIG2 signal, 4-29 to 4-30
- typical posttriggered acquisition (figure), 4-25
- typical pretriggered acquisition (figure), 4-25
- UISOURCE signal, 4-36
- general-purpose timing signal
 - connections, 4-37 to 4-43
 - FREQ_OUT signal, 4-43
 - GPCTR0_GATE signal, 4-38
 - GPCTR0_OUT signal, 4-38
 - to 4-39
 - GPCTR0_SOURCE signal, 4-37
 - to 4-38
 - GPCTR0_UP_DOWN signal, 4-39
 - GPCTR1_GATE signal, 4-40
 - to 4-41
 - GPCTR1_OUT signal, 4-41
 - GPCTR1_SOURCE signal, 4-39
 - to 4-40
 - GPCTR1_UP_DOWN signal, 4-42 to 4-43
- programmable function input
 - connections, 4-24
- types of signal sources, 4-12
 - floating, 4-12
 - ground-referenced, 4-12
- single-ended connections
 - description, 4-18
 - floating signal sources (RSE), 4-19
 - grounded signal sources (NRSE), 4-19
 - to 4-20
 - when to use, 4-18
- SISOURCE signal, 4-35
- software installation, 2-2 to 2-3
- software programming choices
 - LabVIEW and LabWindows/CVI
 - application software, 1-2 to 1-3
 - NI-DAQ driver software, 1-3 to 1-4
 - register-level programming, 1-4
- specifications
 - DAQCard-AI-16E-4
 - analog input, A-1 to A-4
 - amplifier characteristics, A-3
 - dynamic characteristics, A-3
 - to A-4
 - input characteristics, A-1 to A-2
 - stability, A-4
 - transfer characteristics, A-3
 - digital I/O, A-5
 - environment, A-7
 - physical, A-7
 - power requirements, A-7
 - timing I/O, A-5 to A-6
 - triggers
 - analog trigger, A-6
 - digital trigger, A-6
 - DAQCard-AI-16XE-50
 - analog input, A-8 to A-10
 - amplifier characteristics, A-9 to A-10
 - dynamic characteristics, A-10
 - input characteristics, A-8 to A-9
 - stability, A-10
 - transfer characteristics, A-9
 - digital I/O, A-11
 - digital trigger, A-12
 - environment, A-13
 - physical, A-13
 - power requirements, A-12
 - timing I/O, A-11 to A-12
- stability specifications
 - DAQCard-AI-16E-4, A-4
 - DAQCard-AI-16XE-50, A-10
- STARTSCAN signal
 - input timing (figure), 4-31
 - output timing (figure), 4-32
 - timing connections, 4-30 to 4-33

T

technical support, F-1 to F-2

temperature

DAQCard-AI-16E-4, A-7

DAQCard-AI-16XE-50, A-12

theory of operation. *See hardware overview.*

timebases, 3-14

timing connections, 4-22 to 4-43

data acquisition timing connections, 4-24 to 4-36

AIGATE signal, 4-34 to 4-35

CONVERT* signal, 4-33 to 4-34

EXTSTROBE* signal, 4-27

SCANCLK signal, 4-26

SISOURCE signal, 4-35

STARTSCAN signal, 4-30 to 4-33

TRIG1 signal, 4-27 to 4-28

TRIG2 signal, 4-29 to 4-30

typical posttriggered acquisition
(figure), 4-25

typical pretriggered acquisition
(figure), 4-25

UISOURCE signal, 4-36

general-purpose timing signal

connections, 4-37 to 4-43

FREQ_OUT signal, 4-43

GPCTR0_GATE signal, 4-38

GPCTR0_OUT signal, 4-38 to 4-39

GPCTR0_SOURCE signal, 4-37 to
4-38

GPCTR0_UP_DOWN signal, 4-39

GPCTR1_GATE signal, 4-40 to 4-41

GPCTR1_OUT signal, 4-41

GPCTR1_SOURCE signal, 4-39
to 4-40

GPCTR1_UP_DOWN signal, 4-42
to 4-43

programmable function input

connections, 4-24

questions about, D-3 to D-5

timing I/O connections (figure), 4-23

timing I/O specifications

DAQCard-AI-16E-4, A-5 to A-6

DAQCard-AI-16XE-50, A-11 to A-12

timing signal routing, 3-13 to 3-14

CONVERT* signal routing (figure), 3-13

DAQCard clocks, 3-14

programmable function inputs, 3-14

transfer characteristic specifications

DAQCard-AI-16E-4, A-3

DAQCard-AI-16XE-50, A-9

TRIG1 signal

input timing (figure), 4-28

output timing (figure), 4-28

timing connections, 4-27 to 4-28

TRIG2 signal

input timing (figure), 4-30

output timing (figure), 4-30

timing connections, 4-29 to 4-30

triggers

analog, 3-9 to 3-12

above-high-level triggering mode
(figure), 3-10

below-low-level triggering mode
(figure), 3-10

block diagram, 3-9

high-hysteresis triggering
mode, 3-11

inside-region triggering mode
(figure), 3-11

low-hysteresis triggering mode, 3-12
specifications for

DAQCard-AI-16E-4, A-6

digital trigger specifications

DAQCard-AI-16E-4, A-6

DAQCard-AI-16XE-50, A-12

questions about, D-3

troubleshooting. *See questions and answers.*

U

UISOURCE signal, 4-36

unipolar input

 DAQCard-AI-16E-4, 3-3

 DAQCard-AI-16XE-50, 3-4 to 3-5

 mixing bipolar and unipolar channels
 (note), 3-5

unpacking DAQCard E Series, 1-6

V

VCC signal

 DAQCard-AI-16E-4 (table), 4-6

 DAQCard-AI-16XE-50 (table), 4-8

W

Windows 95, configuring your PC Card
(note), C-1

wiring considerations, 4-44