

## COMPREHENSIVE SERVICES

We offer competitive repair and calibration services, as well as easily accessible documentation and free downloadable resources.

## SELL YOUR SURPLUS

We buy new, used, decommissioned, and surplus parts from every NI series. We work out the best solution to suit your individual needs.

 Sell For Cash    Get Credit    Receive a Trade-In Deal

## OBSOLETE NI HARDWARE IN STOCK & READY TO SHIP

We stock **New**, **New Surplus**, **Refurbished**, and **Reconditioned** NI Hardware.



*Bridging the gap between the manufacturer and your legacy test system.*

 1-800-915-6216

 [www.apexwaves.com](http://www.apexwaves.com)

 [sales@apexwaves.com](mailto:sales@apexwaves.com)

*All trademarks, brands, and brand names are the property of their respective owners.*

**Request a Quote**

 **CLICK HERE**

**VXI-1200**

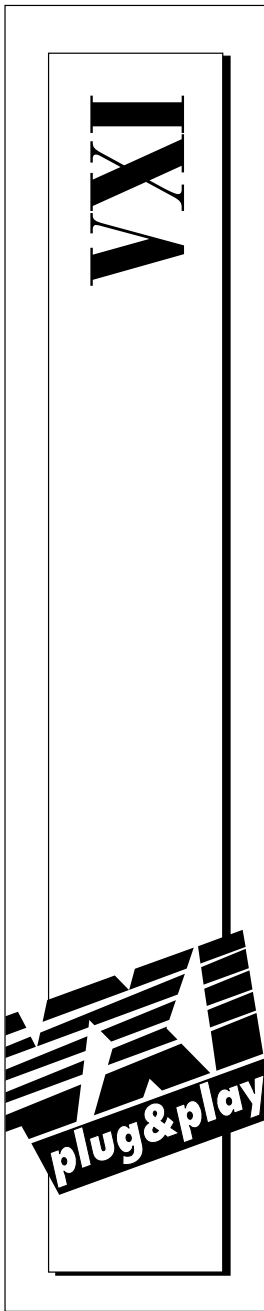

# VXI-1200 User Manual

December 1996 Edition  
Part Number 321404A-01

© Copyright 1996 National Instruments Corporation.  
All Rights Reserved.

---



### **Internet Support**

support@natinst.com

E-mail: info@natinst.com

FTP Site: ftp.natinst.com

Web Address: <http://www.natinst.com>



### **Bulletin Board Support**

BBS United States: (512) 794-5422

BBS United Kingdom: 01635 551422

BBS France: 1 48 65 15 59



### **Fax-on-Demand Support**

(512) 418-1111



### **Telephone Support (U.S.)**

Tel: (512) 795-8248

Fax: (512) 794-5678



### **International Offices**

Australia 02 9874 4100, Austria 0662 45 79 90 0, Belgium 02 757 00 20,  
Canada (Ontario) 905 785 0085, Canada (Québec) 514 694 8521, Denmark 45 76 26 00,  
Finland 09 527 2321, France 01 48 14 24 24, Germany 089 741 31 30, Hong Kong 2645 3186,  
Israel 03 5734815, Italy 02 413091, Japan 03 5472 2970, Korea 02 596 7456,  
Mexico 5 520 2635, Netherlands 0348 433466, Norway 32 84 84 00, Singapore 2265886,  
Spain 91 640 0085, Sweden 08 730 49 70, Switzerland 056 200 51 51, Taiwan 02 377 1200,  
U.K. 01635 523545

### **National Instruments Corporate Headquarters**

6504 Bridge Point Parkway Austin, TX 78730-5039 Tel: (512) 794-0100

# Important Information

---

## Warranty

The VXI-1200 mainframe is warranted against defects in materials and workmanship for a period of one year from the date of shipment, as evidenced by receipts or other documentation. National Instruments will, at its option, repair or replace equipment that proves to be defective during the warranty period. This warranty includes parts and labor.

A Return Material Authorization (RMA) number must be obtained from the factory and clearly marked on the outside of the package before any equipment will be accepted for warranty work. National Instruments will pay the shipping costs of returning to the owner parts which are covered by warranty.

National Instruments believes that the information in this manual is accurate. The document has been carefully reviewed for technical accuracy. In the event that technical or typographical errors exist, National Instruments reserves the right to make changes to subsequent editions of this document without prior notice to holders of this edition. The reader should consult National Instruments if errors are suspected. In no event shall National Instruments be liable for any damages arising out of or related to this document or the information contained in it.

EXCEPT AS SPECIFIED HEREIN, NATIONAL INSTRUMENTS MAKES NO WARRANTIES, EXPRESS OR IMPLIED, AND SPECIFICALLY DISCLAIMS ANY WARRANTY OF MERCHANTABILITY OR FITNESS FOR A PARTICULAR PURPOSE. CUSTOMER'S RIGHT TO RECOVER DAMAGES CAUSED BY FAULT OR NEGLIGENCE ON THE PART OF NATIONAL INSTRUMENTS SHALL BE LIMITED TO THE AMOUNT THEREFORE PAID BY THE CUSTOMER. NATIONAL INSTRUMENTS WILL NOT BE LIABLE FOR DAMAGES RESULTING FROM LOSS OF DATA, PROFITS, USE OF PRODUCTS, OR INCIDENTAL OR CONSEQUENTIAL DAMAGES, EVEN IF ADVISED OF THE POSSIBILITY THEREOF. This limitation of the liability of National Instruments will apply regardless of the form of action, whether in contract or tort, including negligence. Any action against National Instruments must be brought within one year after the cause of action accrues. National Instruments shall not be liable for any delay in performance due to causes beyond its reasonable control. The warranty provided herein does not cover damages, defects, malfunctions, or service failures caused by owner's failure to follow the National Instruments installation, operation, or maintenance instructions; owner's modification of the product; owner's abuse, misuse, or negligent acts; and power failure or surges, fire, flood, accident, actions of third parties, or other events outside reasonable control.

## Copyright

Under the copyright laws, this publication may not be reproduced or transmitted in any form, electronic or mechanical, including photocopying, recording, storing in an information retrieval system, or translating, in whole or in part, without the prior written consent of National Instruments Corporation.

## Trademarks

FlexFrame™ is a trademark of National Instruments.

Product and company names listed are trademarks or trade names of their respective companies.

## WARNING REGARDING MEDICAL AND CLINICAL USE OF NATIONAL INSTRUMENTS PRODUCTS

National Instruments products are not designed with components and testing intended to ensure a level of reliability suitable for use in treatment and diagnosis of humans. Applications of National Instruments products involving medical or clinical treatment can create a potential for accidental injury caused by product failure, or by errors on the part of the user or application designer. Any use or application of National Instruments products for or involving medical or clinical treatment must be performed by properly trained and qualified medical personnel, and all traditional medical safeguards, equipment, and procedures that are appropriate in the particular situation to prevent serious injury or death should always continue to be used when National Instruments products are being used. National Instruments products are NOT intended to be a substitute for any form of established process, procedure, or equipment used to monitor or safeguard human health and safety in medical or clinical treatment.

# FCC/DOC Radio Frequency Interference Class A Compliance

---

This equipment generates and uses radio frequency energy and, if not installed and used in strict accordance with the instructions in this manual, may cause interference to radio and television reception. Classification requirements are the same for the Federal Communications Commission (FCC) and the Canadian Department of Communications (DOC). This equipment has been tested and found to comply with the following two regulatory agencies:

## Federal Communications Commission

This equipment has been tested and found to comply with the limits for a Class A digital device, pursuant to part 15 of the FCC Rules. These limits are designed to provide reasonable protection against harmful interference when the equipment is operated in a commercial environment. This equipment generates, uses, and can radiate radio frequency energy and, if not installed and used in accordance with the instruction manual, may cause harmful interference to radio communications. Operation of this equipment in a residential area is likely to cause harmful interference in which case the user will be required to correct the interference at his own expense.

**Notices to User:** *Changes or modifications not expressly approved by National Instruments could void the user's authority to operate the equipment under the FCC Rules.*

*This device complies with the FCC rules only if used with shielded interface cables of suitable quality and construction. National Instruments used such cables to test this device and provides them for sale to the user. The use of inferior or nonshielded interface cables could void the user's authority to operate the equipment under the FCC rules.*

If necessary, consult National Instruments or an experienced radio/television technician for additional suggestions. The following booklet prepared by the FCC may also be helpful: *Interference to Home Electronic Entertainment Equipment Handbook*. This booklet is available from the U.S. Government Printing Office, Washington, DC 20402.

## Canadian Department of Communications

This Class A digital apparatus meets all requirements of the Canadian Interference-Causing Equipment Regulations.

Cet appareil numérique de la classe A respecte toutes les exigences du Règlement sur le matériel brouilleur du Canada.

# For Your Safety

---

Before undertaking any troubleshooting, maintenance, or exploratory procedure, read carefully the **WARNING** and **CAUTION** notices.

This equipment contains voltage hazardous to human life and safety, and is capable of inflicting personal injury.

If this instrument is to be powered from the AC line (mains) through an autotransformer, ensure the common connector is connected to the neutral (earthed pole) of the power supply.

Before operating the unit, ensure the conductor (green wire) is connected to the ground (earth) conductor of the power outlet. Do not use a two-conductor extension cord or a three-prong/two-prong adapter. This will defeat the protective feature of the third conductor in the power cord.

Maintenance and calibration procedures sometimes call for operation of the unit with power applied and protective covers removed. Read the procedures and heed warnings to avoid live circuit points.

Before operating this instrument ensure the following:

- The instrument is configured to operate on the voltage at the power source.
- The proper fuse is in place for the power source to operate.
- All other devices connected to or in proximity to this instrument are properly grounded or connected to the protective third-wire earth ground.

Have performance checked by qualified personnel if the instrument fails to operate satisfactorily, shows visible damage, has been stored under unfavorable conditions, or has sustained stress.

A rectangular box containing the text "Table of Contents" in a serif font, with a thick black border and a drop shadow effect.

*Table  
of  
Contents*

---

## About This Manual

Organization of This Manual .....	xi
Conventions Used in This Manual.....	xii
Customer Communication .....	xii

## Chapter 1 Getting Started

What You Need to Get Started .....	1-1
Optional Equipment.....	1-1
Key Features .....	1-2
Ease of Use .....	1-2
Portable Bench-Top Mainframe .....	1-3
Three Slot Locations for B-Size VXI/VME Modules.....	1-4
Rack-Mount Configuration (5U Footprint).....	1-5
Modular Mainframe Design.....	1-6
720 Watts Available DC Power.....	1-7
High-Capacity Positive-Pressure Cooling system .....	1-8
Bench-Top Cooling System .....	1-8
Rack-Mount Cooling System .....	1-9
Rack-Mount Options .....	1-10
Backplane.....	1-10

## Chapter 2 Configuring the VXI-1200

AC Mains Power.....	2-1
Site Considerations .....	2-2
Select VXIbus Slot 0 Controller Location.....	2-2
Installing VXI Modules .....	2-3
Installing and Removing Card-Guide Covers (Airflow Directors) .....	2-4
Installing Filler Panels .....	2-6
Installing ASFP Panel .....	2-6
Installing Rack-Mount Door .....	2-7

Connecting Safety Ground.....	2-8
Fan Speed Range .....	2-9

## Chapter 3

### Operating the VXI-1200

Powering on the Mainframe.....	3-3
Using Remote Power On/Standby Switching .....	3-4
Rear Panel Switch and Connector Descriptions .....	3-5
Backplane Connections .....	3-7
Basic Functional Check .....	3-11

## Chapter 4

### Understanding the VXI-1200

Power Supply.....	4-2
Power Supply Interconnection .....	4-2
Power Supply Protections .....	4-2
Backplane.....	4-3
Backplane Interconnections.....	4-3
Cooling System.....	4-4
Cooling the Power Supply.....	4-4

## Chapter 5

### Maintenance

Service Strategy .....	5-1
Service Interval.....	5-1
Preparation.....	5-2
Inspection and Cleaning.....	5-2
Interior Cleaning .....	5-3
Exterior Cleaning.....	5-3
Cleaning the Fan Filters.....	5-4
Removing and Replacing the AC Mains Fuse.....	5-5
Troubleshooting the VXI-1200.....	5-6

## Appendix A

### Specifications

## Appendix B

### Customer Communication



## Glossary

## Index

## Figures

Figure 1-1.	VXI-1200 Portable Streamlined (5U Wide) Mainframe in Bench-Top Configuration .....	1-3
Figure 1-2.	Three Slot Locations for B-Size VXI/VME Modules .....	1-4
Figure 1-3.	VXI-1200 Rack-Mount (5U Tall) Configuration .....	1-5
Figure 1-4.	Modular Service Friendly Mainframe Design Features .....	1-6
Figure 1-5.	VXI-1200 720 Watt Power Supply.....	1-7
Figure 1-6.	VXI-1200 Bench-Top Configuration Positive-Pressure Cooling System.....	1-8
Figure 1-7.	VXI-1200 Rack-Mount Configuration Positive-Pressure Cooling System.....	1-9
Figure 2-1.	Select VXIbus Slot 0 Controller Location.....	2-3
Figure 2-2.	Airflow Directors.....	2-4
Figure 2-3.	Filler Panels .....	2-6
Figure 2-4.	Installing Rack-Mount Door.....	2-7
Figure 2-5.	Connecting Safety Ground .....	2-8
Figure 2-6.	Fan Speed Range Selection .....	2-9
Figure 3-1.	VXI-1200 Front View.....	3-1
Figure 3-2.	VXI-1200 Rear View .....	3-2
Figure 3-3.	Powering on the Mainframe .....	3-3
Figure 3-4.	Using Remote Power On/Standby Switching.....	3-4
Figure 4-1.	VXI-1200 Block Diagram .....	4-1
Figure 5-1.	Cleaning the Fan Filters.....	5-4
Figure 5-2.	Removing and Replacing the AC Mains Fuse .....	5-5
Figure A-1.	Mainframe Worst-Case Slot Cooling Curve.....	A-5

## Tables

Table 1-1.	VXI-1200 Available DC Current .....	1-7
Table 3-1.	J415 Rear-Panel Monitor/Control Connector.....	3-6
Table 3-2.	P1 Connector Pinouts .....	3-8
Table 3-3.	P2 Connector Pinouts for All Non-Slot 0 Locations .....	3-9
Table 3-4.	P2 Connector Pinouts for VXIbus Slot 0 (C0 or B0) .....	3-10
Table 3-5.	Power Supply Voltages at J415 .....	3-11
Table 5-1.	Troubleshooting .....	5-6



*About  
This  
Manual*

---

The *VXI-1200 User Manual* describes the features of the VXI-1200 FlexFrame, hereafter referred to as the VXI-1200. This manual contains information about configuring the mainframe, installing modules, operating and using the VXI-1200.

## Organization of This Manual

---

This manual is organized as follows:

- Chapter 1, *Getting Started*, describes the key features of the VXI-1200, gives an overview of the bench-top and rack-mount applications, and lists optional equipment you can order from National Instruments.
- Chapter 2, *Configuring the VXI-1200*, includes procedures to install and configure the VXI-1200.
- Chapter 3, *Operating the VXI-1200*, explains the front- and rear-panel controls and indicators and describes how to use the VXI-1200.
- Chapter 4, *Understanding the VXI-1200*, describes the major functional blocks of the VXI-1200 FlexFrame—the power supply, backplane, and cooling system.
- Chapter 5, *Maintenance*, describes basic maintenance procedures you can perform on the VXI-1200 FlexFrame.
- Appendix A, *Specifications*, contains complete specifications for the VXI-1200.
- Appendix B, *Customer Communication*, contains forms you can use to request help from National Instruments or to comment on our products and manuals.
- The *Glossary* contains an alphabetical list and description of terms used in this manual, including abbreviations, acronyms, metric prefixes, mnemonics, and symbols.

- The *Index* contains an alphabetical list of key terms and topics in this manual, including the page where you can find each one.

## Conventions Used in This Manual

---

The following conventions are used in this manual:

***bold italic***

Bold italic text denotes a note, caution, or warning.

*italic*

Italic text denotes emphasis, a cross reference, or an introduction to a key concept.

Abbreviations, acronyms, metric prefixes, mnemonics, symbols, and terms are listed in the *Glossary*.

## Customer Communication

---

National Instruments wants to receive your comments on our products and manuals. We are interested in the applications you develop with our products, and we want to help if you have problems with them. To make it easy for you to contact us, this manual contains comment and configuration forms for you to complete. These forms are in Appendix B, *Customer Communication*, at the end of this manual.

# Getting Started

---

This chapter describes the key features of the VXI-1200, gives an overview of the bench-top and rack-mount applications, and lists optional equipment you can order from National Instruments.

The VXI-1200 FlexFrame is a 9-slot VXIbus mainframe. The VXI-1200 can accommodate up to six C-size VXI modules and up to three B-size VXI or VME modules. A plug-in Personality module allows either the C0 slot or B0 slot to function as the mainframe VXIbus Slot 0 location. The VXI-1200 fully complies with the VXIbus Specification Revision 1.4 requirements and is *VXIplug&play* compatible.

## What You Need to Get Started

---

The VXI-1200 kit includes the following items.

- VXI-1200 mainframe
- Power cable
- Three card-guide covers

## Optional Equipment

---

You can order the following options from National Instruments.

- Rack-mount kit with slides and cable tray
- Rack-mount kit with rails and cable tray
- Plexiglas front door
- Application-specific front panel
- Backplane with connector shrouds installed
- Intermodule mainframe shield kit
- C-size and B-size filler panels

# Key Features

---

Figures 1-1 through 1-7 show the key features of the VXI-1200.

## Ease of Use

The VXI-1200 is designed for easy and convenient use.

- **Plug-in Personality Module.** The orientation of the plug-in Personality module allows either the C0 slot or B0 slot to function as the mainframe VXIbus Slot 0 location.
- **Fast Setup.** The VXI-1200 backplane uses active-automatic VME interrupt acknowledge and bus grant daisy chaining. Manual configuration of backplane switch settings or jumpers has been eliminated.
- **Universal AC Input.** The VXI-1200 AC input is both auto-voltage and auto-frequency ranging. The chassis does not require the configuration of a voltage selection switch.
- **Plug-in Power Supply, Fans, and Monitor.** The VXI-1200 modular system design results in a virtually wireless mainframe with low MTTR and high MTBF. See Figure 1-3.
- **Variable Extension Rack-Mounting.** The adjustable rack-mount ear provides variable (0.500 in. increments) extension rack-mounting capability.
- **Fan Speed Control.** The VXI-1200 delivers the cooling air that your application requires. Fan speed control reduces acoustic noise levels of the VXI-1200 high-performance cooling system.

## Portable Bench-Top Mainframe

The VXI-1200 is a portable streamlined high-performance 9-slot VXI mainframe that is only 5U (8.720 in.) wide when used in a bench-top configuration, as shown in Figure 1-1.

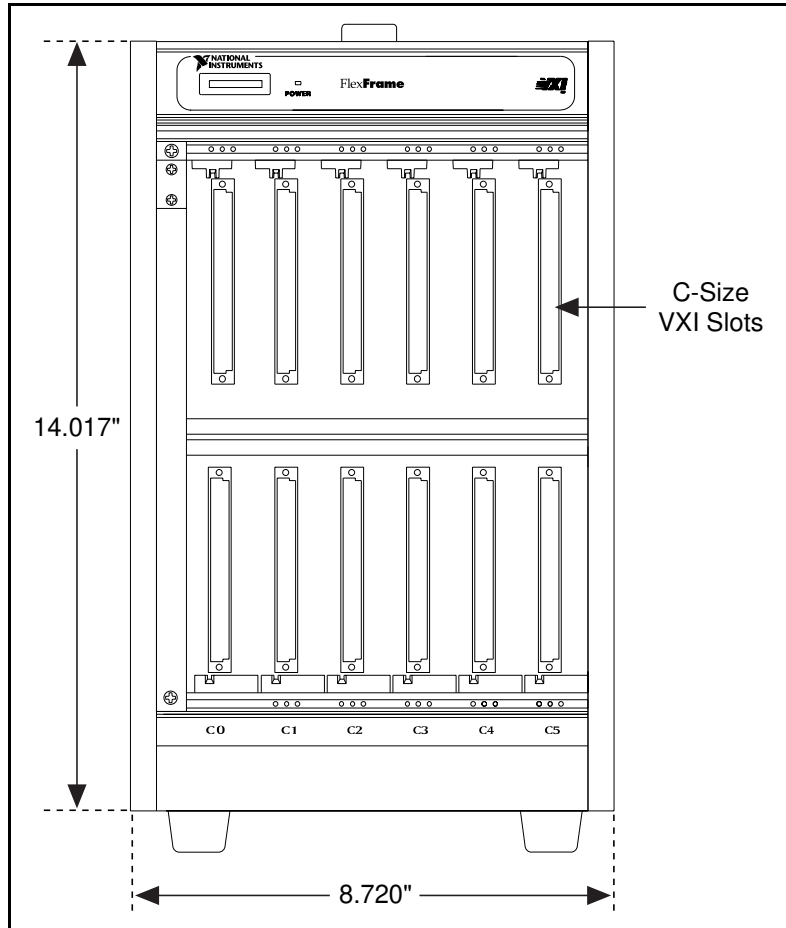

**Figure 1-1.** VXI-1200 Portable Streamlined (5U Wide) Mainframe in Bench-Top Configuration

## Three Slot Locations for B-Size VXI/VME Modules

The VXI-1200 backplane can accommodate up to six C-size VXI modules and up to three B-size VXI or VME modules. The plug-in Personality module allows either the C0 slot or B0 slot to function as the mainframe VXIbus Slot 0 location.

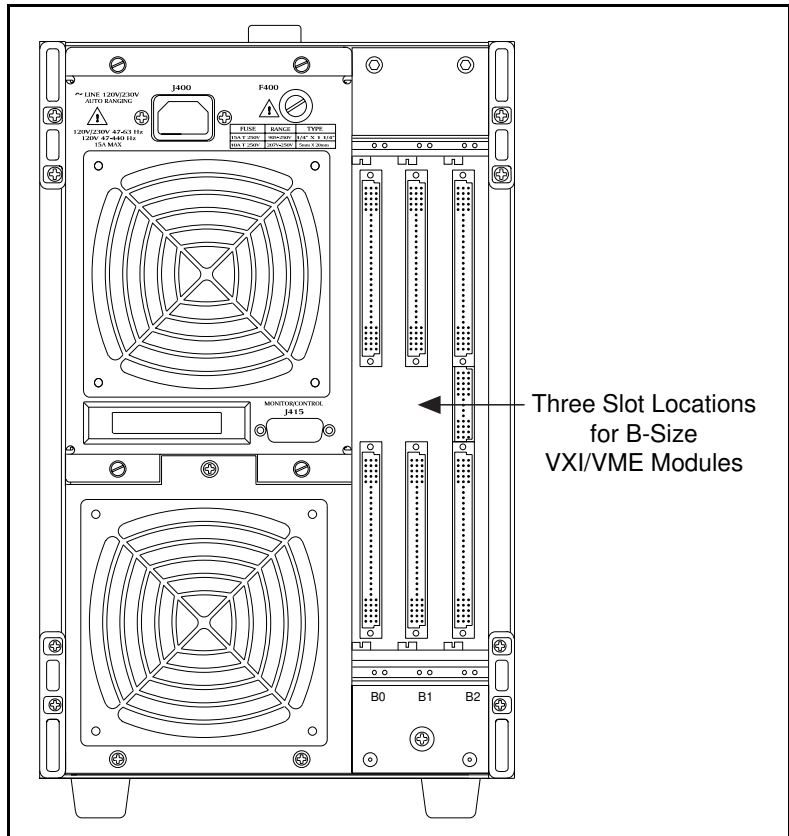

Figure 1-2. Three Slot Locations for B-Size VXI/VME Modules





# Modular Mainframe Design

The VXI-1200 highly modular design is virtually wireless with low MTTR and high MTBF.

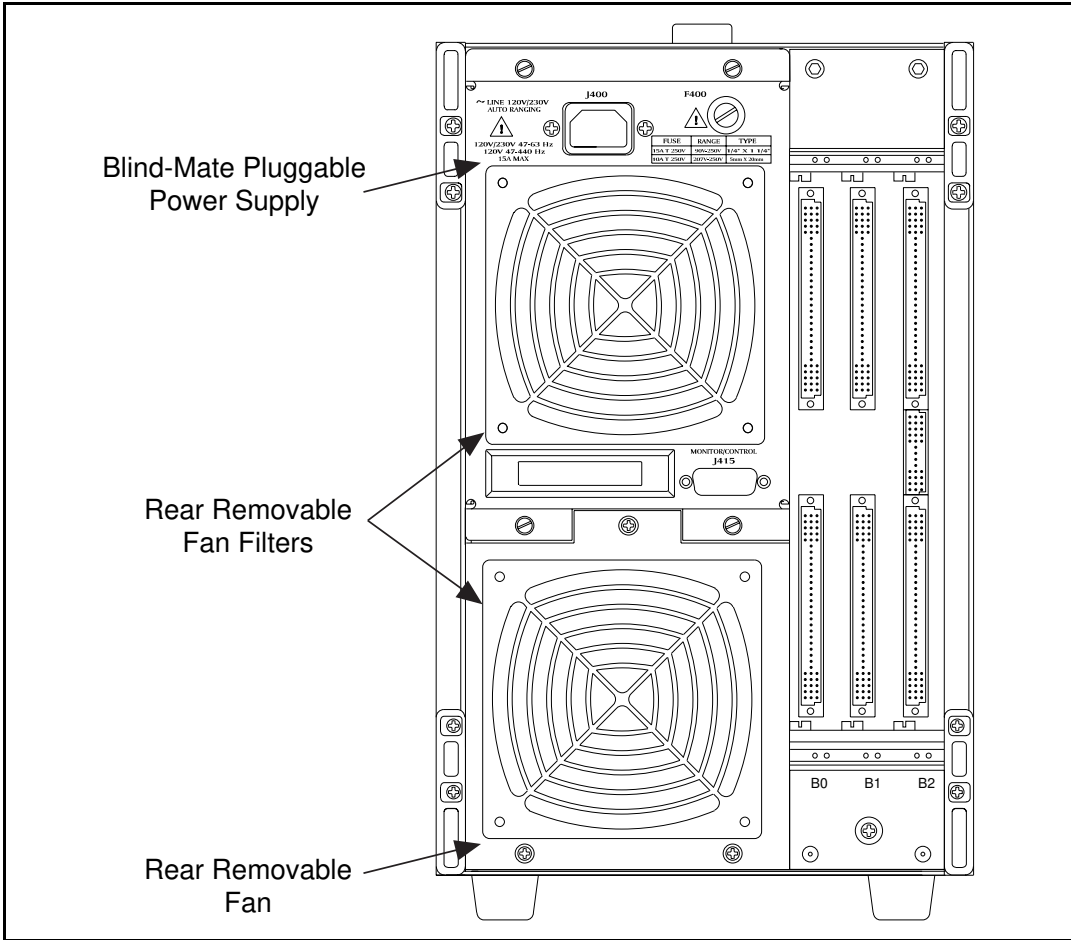
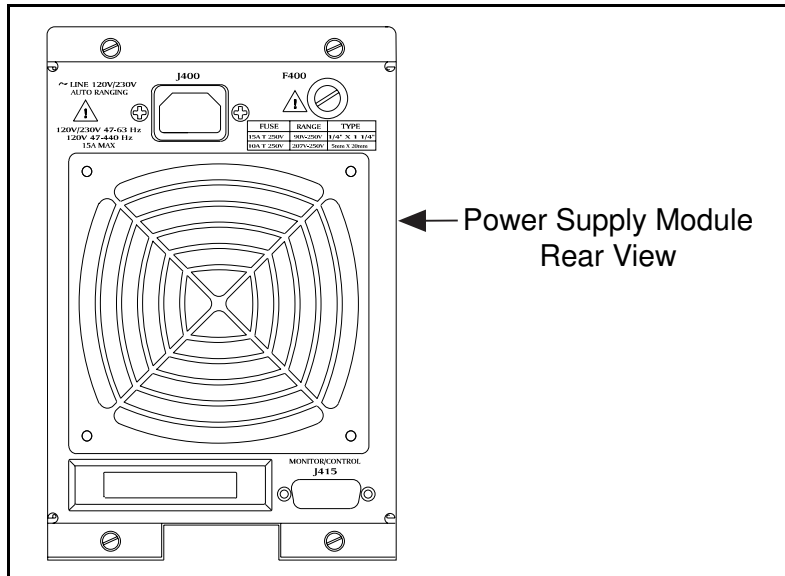

Figure 1-4. Modular Service Friendly Mainframe Design Features

## 720 Watts Available DC Power

Figure 1-5 depicts the VXI-1200 mainframe's 720 W plug-in power supply. Table 1-1 lists the available DC current for each VXI voltage.



**Figure 1-5.** VXI-1200 720 Watt Pluggable Power Supply

**Table 1-1.** VXI-1200 Available DC Current

VXI Voltage	Available DC Current
+5 V	54 A
-5.2 V	12 A
-2 V	12 A
+12 V	8 A
-12 V	8 A
+24 V	4 A
-24 V	4 A

## High-Capacity Positive-Pressure Cooling System

The VXI-1200 uses forced-air positive-pressure cooling to direct air to the VXI modules.

### Bench-Top Cooling System

Figure 1-6 details the cooling system in the bench-top configuration.

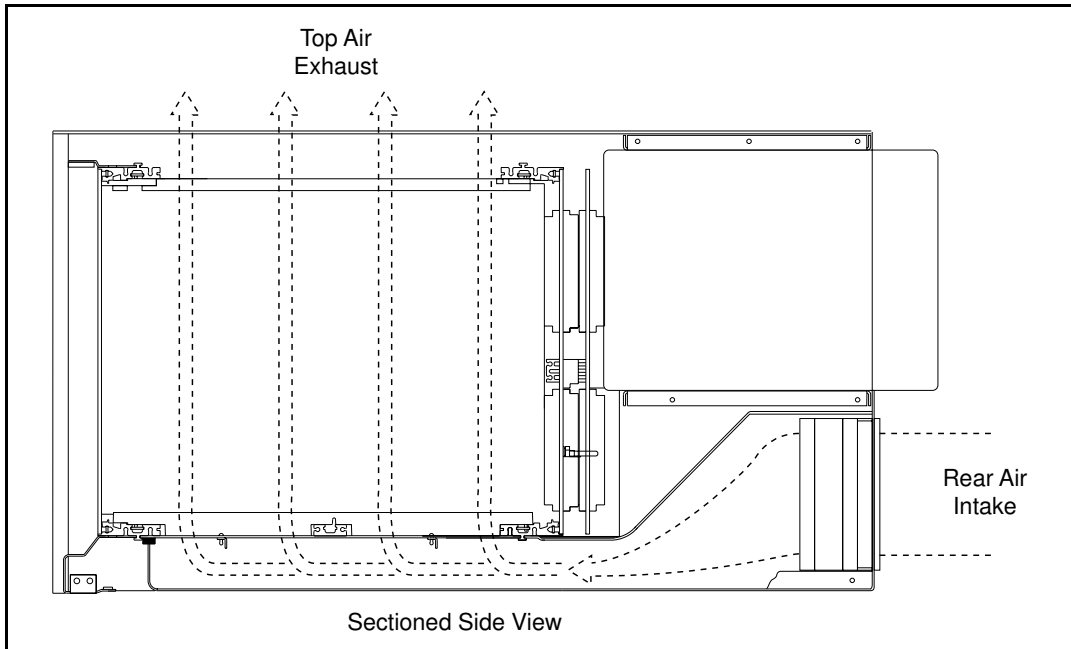

**Figure 1-6.** VXI-1200 Bench-Top Configuration Positive-Pressure Cooling System

## Rack-Mount Cooling System

Figure 1-7 details the VXI-1200 cooling system in the rack-mount configuration.

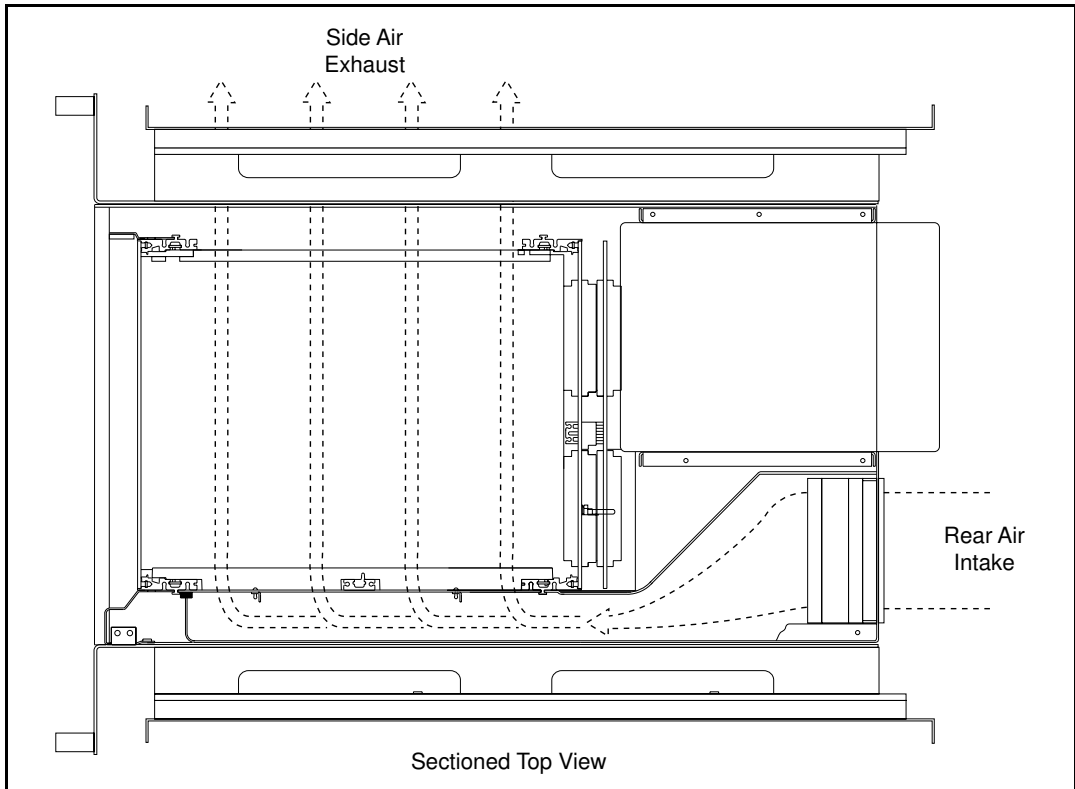

**Figure 1-7.** VXI-1200 Rack-Mount Configuration Positive-Pressure Cooling System

## Rack-Mount Options

---

The VXI-1200 is available with a wide variety of rack-mount options. The adjustable rack-mount ear provides variable extension rack-mounting capability.

You can order rack-mount kits using either slides or rails. The kits include documentation to guide you through the installation.

## Backplane

---

The VXI-1200 backplane can accommodate up to six C-size VXI modules and up to three B-size VXI or VME modules. The plug-in Personality module allows either the C0 slot or B0 slot to function as the mainframe VXIbus Slot 0 location.

The VXI-1200 has a jumperless auto-configurable backplane using active-automatic daisy chaining for the VME interrupt acknowledge and bus grant daisy-chain signal lines. This eliminates the need to manually configure the backplane.

Distribution of the CLK10 reference clock is full differential providing a low skew timing source.

Power is supplied to the backplane through a direct connection to the VXI-1200 power supply eliminating wiring and sub-backplane interconnect boards. The result is increased reliability and improved dynamic current performance.

# Configuring the VXI-1200

---

This chapter includes procedures to install and configure the VXI-1200. Use this chapter to perform the following tasks.

- Review installation site considerations.
- Configure the VXI-1200 to allow the VXIbus Slot 0 controller to reside in either the front C0 slot or the rear B0 slot.
- Install VXI modules, card-guide covers, or optional filler panels.
- Connect safety ground.
- Reconfigure fan speed range (HI - LO) setting.

## AC Mains Power

---

The VXI-1200 AC input is both auto-voltage and auto-frequency ranging, and requires no voltage switch selection.

The standard VXI-1200 is configured for 120 VAC operation. Should it be necessary to replace the AC mains fuse (F400), refer to the *Removing and Replacing the AC Mains Fuse* section in Chapter 5, *Maintenance*.



**Warning:** *For your protection from electrical shock when operating at mains frequencies greater than 63 Hz, connect the chassis safety ground terminal to permanent earth ground. See Figure 2-5.*

## Site Considerations

---

The VXI-1200 mainframe is designed to operate on a bench or in an instrument rack. Refer to Figures 1-6 and 1-7 in the previous chapter for vent locations for the VXI-1200 when used in bench-top and rack-mount applications, respectively. Determine how you will use your VXI-1200 (bench-top or rack-mount) and follow the appropriate installation instructions.

Rack-mount kits are available using either slides or rails. Follow the instructions in the installation guide that comes with the kit.

## Select VXIbus Slot 0 Controller Location

---

The VXI-1200 is factory configured for operation with the VXIbus Slot 0 controller located in the front C0 slot. You can reconfigure the VXI-1200 to locate the VXIbus Slot 0 controller in the rear B0 slot, freeing one full C-sized instrument slot. Refer to Figure 2-1 as you follow these steps to configure the mainframe to operate with the VXIbus Slot 0 controller located in the rear B0 slot.

1. Remove the Personality module retaining screw located at the bottom left-side panel. Retain for later installation.
2. Grasp the Personality module using the finger cutout and remove from the J57 card-edge connector located on the backplane by pulling gently and evenly toward the front.
3. Rotate the Personality module 180° so that the silkscreen reads as follows:

—>

SLOT 0 LOCATED IN  
REAR B-SIZED SLOT

4. Install the Personality module (so that the silk screen reads as shown above in step 3) into the J57 card-edge connector by aligning the Personality module with the connector and gently pushing toward the rear.
5. Install the Personality module retaining screw and tighten until snug. Do not over tighten.



# Installing VXI Modules

Install C-size modules directly into the six front C-size slots of the mainframe by first placing the module's card edges into the front module guides (top and bottom). Slide the module to the rear of the mainframe until the module connectors mate solidly with the backplane connectors. Secure the module's front panel to the mainframe using the module's front-panel mounting screws.

Install B-size modules directly into the three rear B-size slots of the mainframe by first placing the module's card edges into the rear module guides (top and bottom). Slide the module to the front of the mainframe until the module connectors mate solidly with the backplane connectors. Secure the module's front panel to the mainframe using the module's front-panel mounting screws.

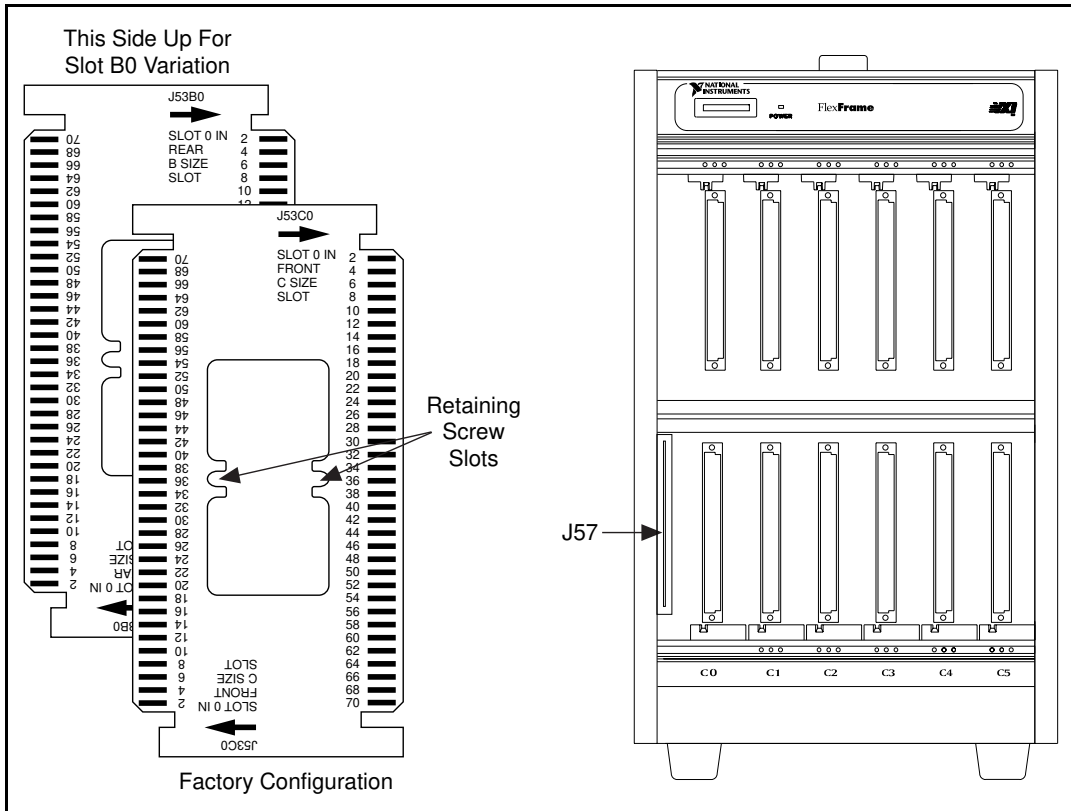

**Figure 2-1.** Select VXIbus Slot 0 Controller Location



**Caution:** *To avoid possible damage do NOT apply power to the mainframe with modules installed until you have configured the VXIbus Slot 0 controller location, as described in the previous section.*

## Installing and Removing Card Guide Covers (Airflow Directors)

To improve the cooling of used slots in the VXI mainframe, a limited number of airflow directors can be installed at empty slot locations to redirect otherwise wasted airflow.



**Caution:** *To maintain a balanced airflow throughout the system when using airflow directors, do not cover more than three empty slots at any time. If module density is low, space airflow directors evenly across the mainframe.*

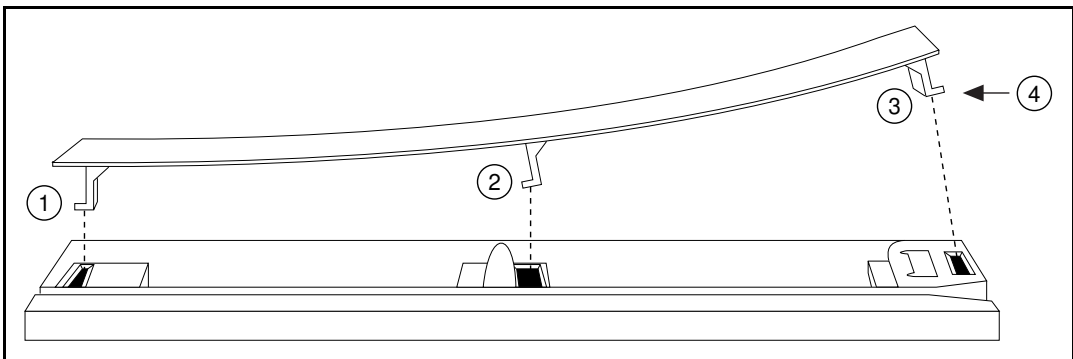

**Figure 2-2.** Airflow Directors

1. Facing the front of the VXI mainframe, with one hand hold the airflow director by the front end where the logo appears.
2. Select the slot to be covered by the director, and place the hook at the rear of the director into the rectangular hole at the rear of the card guide (1). You may need to use your other hand to gently press down on top of the director at the rear to engage the hook into the card guide.
3. Slightly flex the director upward at the front, maintaining pressure at the rear, and lower the center hook of the director into the center rectangular hole in the card guide (2).

4. Press down and back to allow both the center and rear hooks to engage fully into the card guide.
5. Lower the front of the director and allow the snap-in hook to rest on the card guide (3).
6. With a slotted screwdriver or similar flat-bladed tool, depress the spring hook (4) at a slight downward angle, applying light pressure to the logo area. This will cause the snap-in hook to firmly seat the director into place.
7. To remove the airflow director, depress the snap-in hook (4) from the front with a flat-bladed tool. This will unlatch the hook and allow removal from the card guide at the front end.
8. Pull forward to release the fixed hooks at the center and rear.

## Installing Filler Panels

To optimize module cooling performance, you should install optional filler panels into unused or empty slots. Secure with two captive mounting screws. Refer to Figure 2-3.

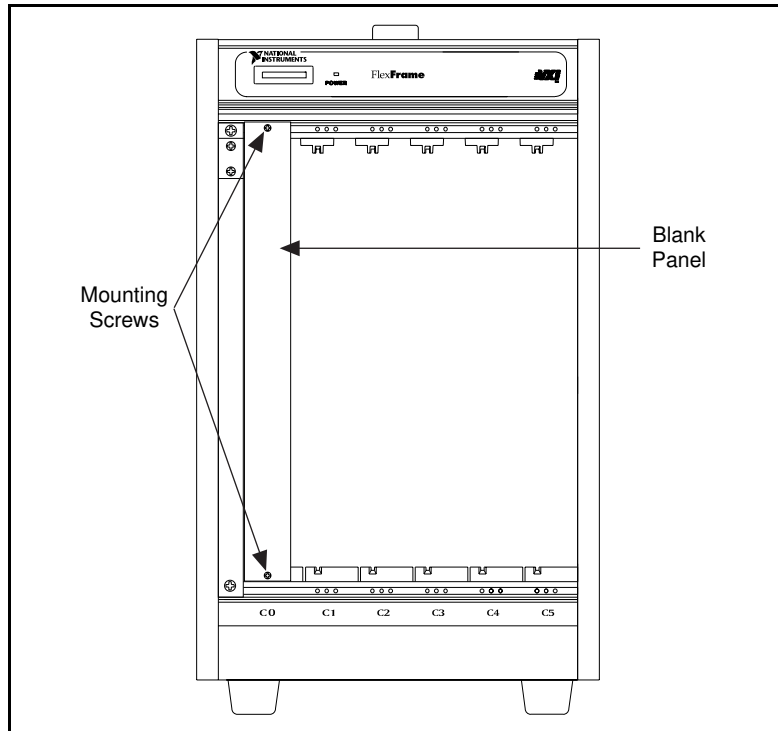

Figure 2-3. Filler Panels

## Installing ASFP Panel

Instructions for installing the Application-Specific Front Panel (ASFP) into the VXI-1200 are included in the kit that is shipped with the option.

## Installing Rack-Mount Door

Instructions for installing rack-mount kits for the VXI-1200 are included in the kit that is shipped with the rack-mount option. When you are finished installing the rack-mount kit, install the rack-mount door as shown in Figure 2-4.

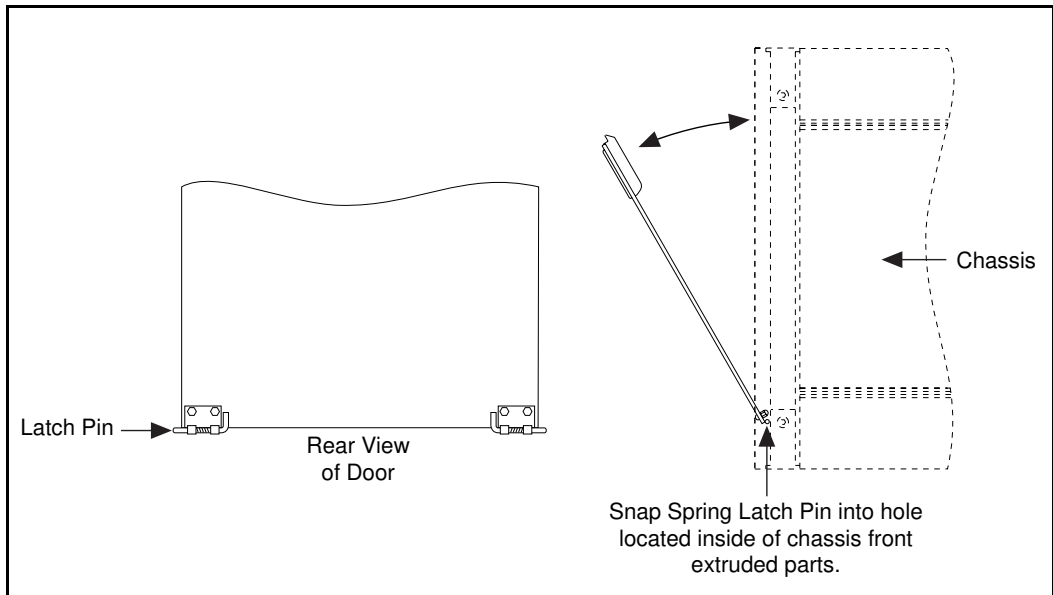

**Figure 2-4.** Installing Rack-Mount Door

## Connecting Safety Ground

Omit this procedure if you do not intend to operate the VXI-1200 at frequencies greater than 63 Hz. When operating the VXI-1200 at mains frequencies between 47 Hz and 63 Hz, use the chassis (safety) ground connection to connect the grounds of one or more instruments to the mainframe. This ensures a common ground connection between instruments.



**Warning:** *For your protection from electrical shock when operating at mains frequencies greater than 63 Hz, connect the chassis safety ground terminal to permanent earth ground. See Figure 2-5.*

1. Connect a 16 AWG (1.3 mm<sup>2</sup> or larger) wire to the 8-32 chassis (safety) grounding screw using a toothed grounding lug. The wire insulation must be green with a yellow stripe or non-insulated (bare).
2. Attach the opposite end of the wire to permanent earth ground using toothed washers or a toothed lug.

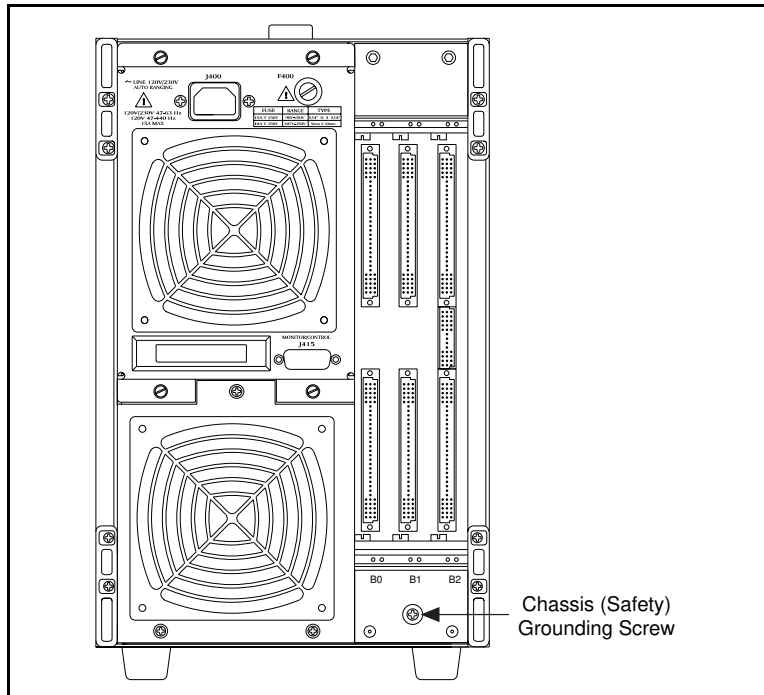
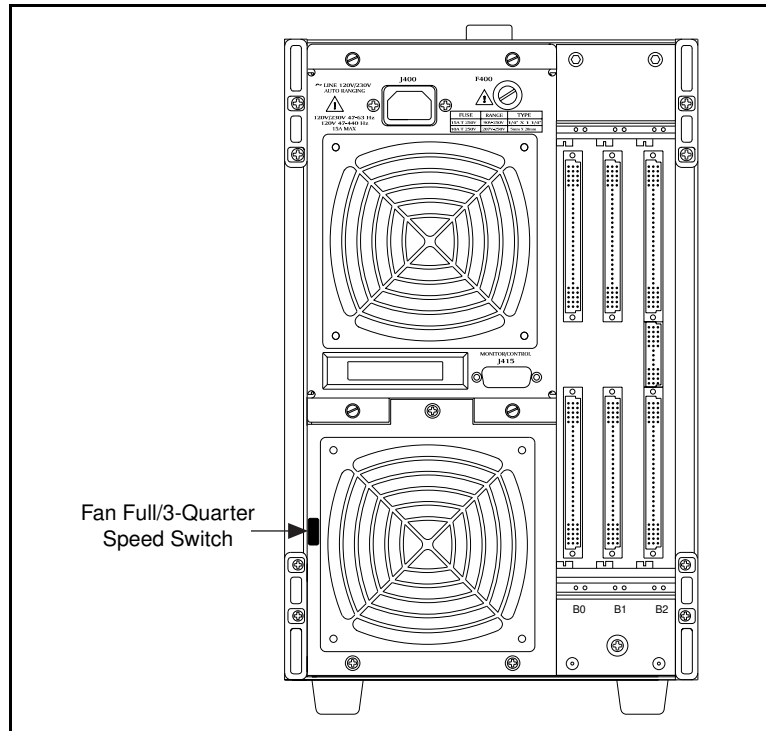

Figure 2-5. Connecting Safety Ground

# Fan Speed Range

You can manually select between full or reduced fan speed by adjusting the position of the full/three-quarter fan-speed switch. Refer to Figure 2-6.

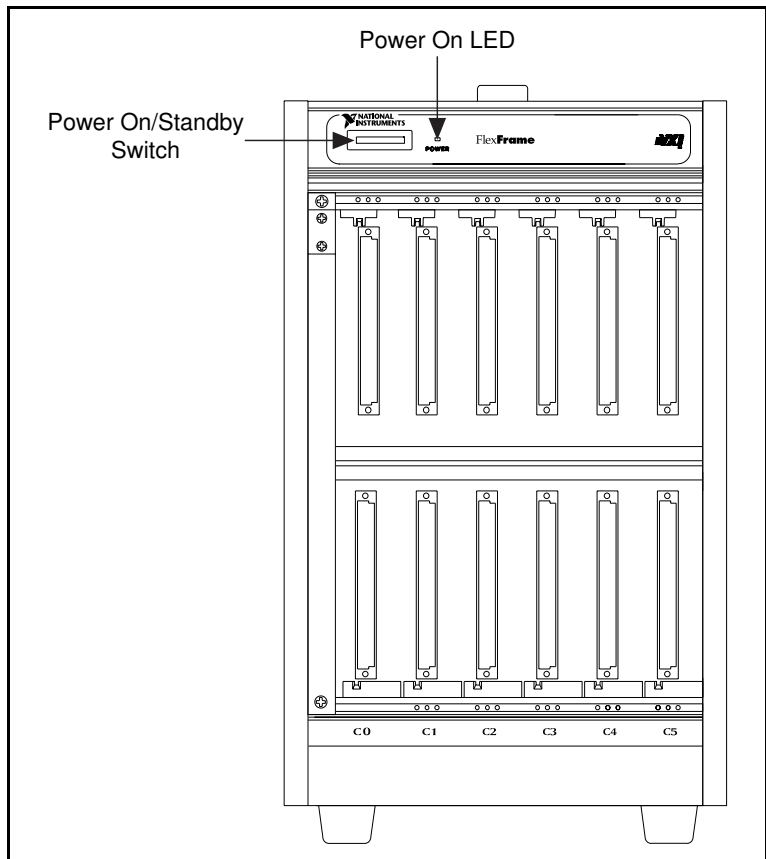

**Figure 2-6.** Fan Speed Range Selection

# Operating the VXI-1200

This chapter explains the front- and rear-panel controls and indicators and describes how to use the VXI-1200.

Figures 3-1 and 3-2 show the VXI-1200 front and rear, respectively.



**Figure 3-1.** VXI-1200 Front View



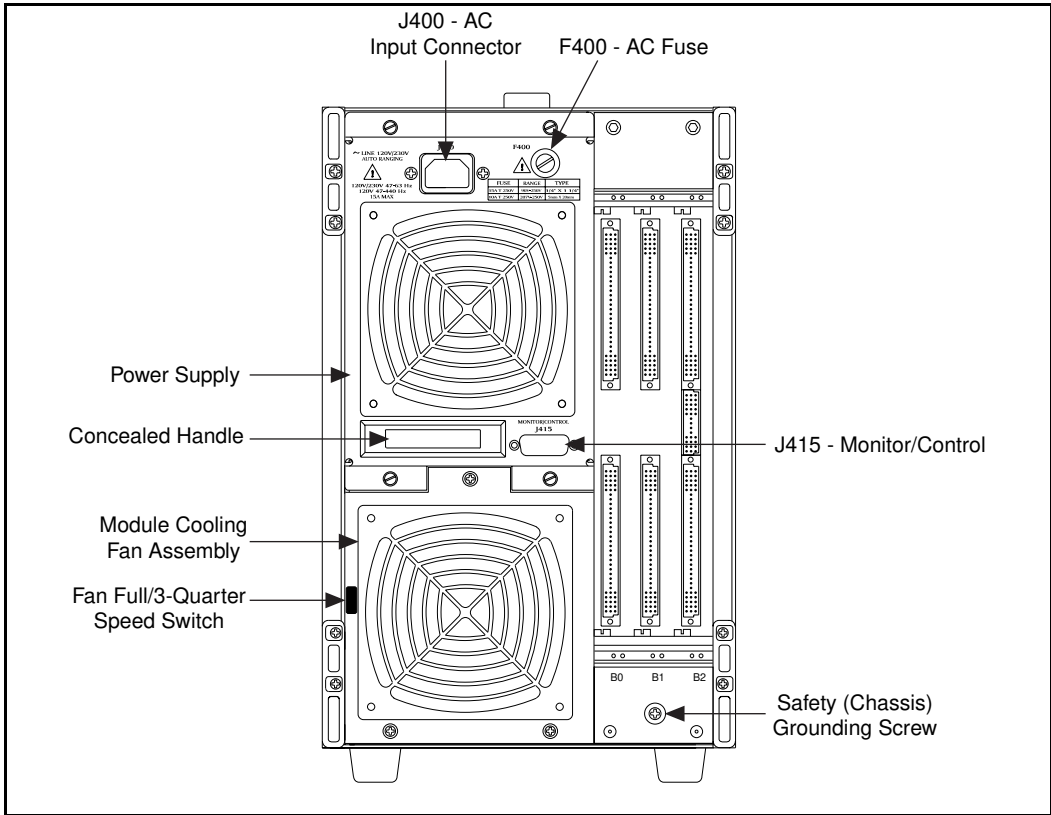

Figure 3-2. VXI-1200 Rear View

See the *Rear Panel Switch and Connector Descriptions* section later in this chapter for information on rear-panel features.

# Powering on the Mainframe

Figure 3-3 shows the steps you should perform when powering on the mainframe.

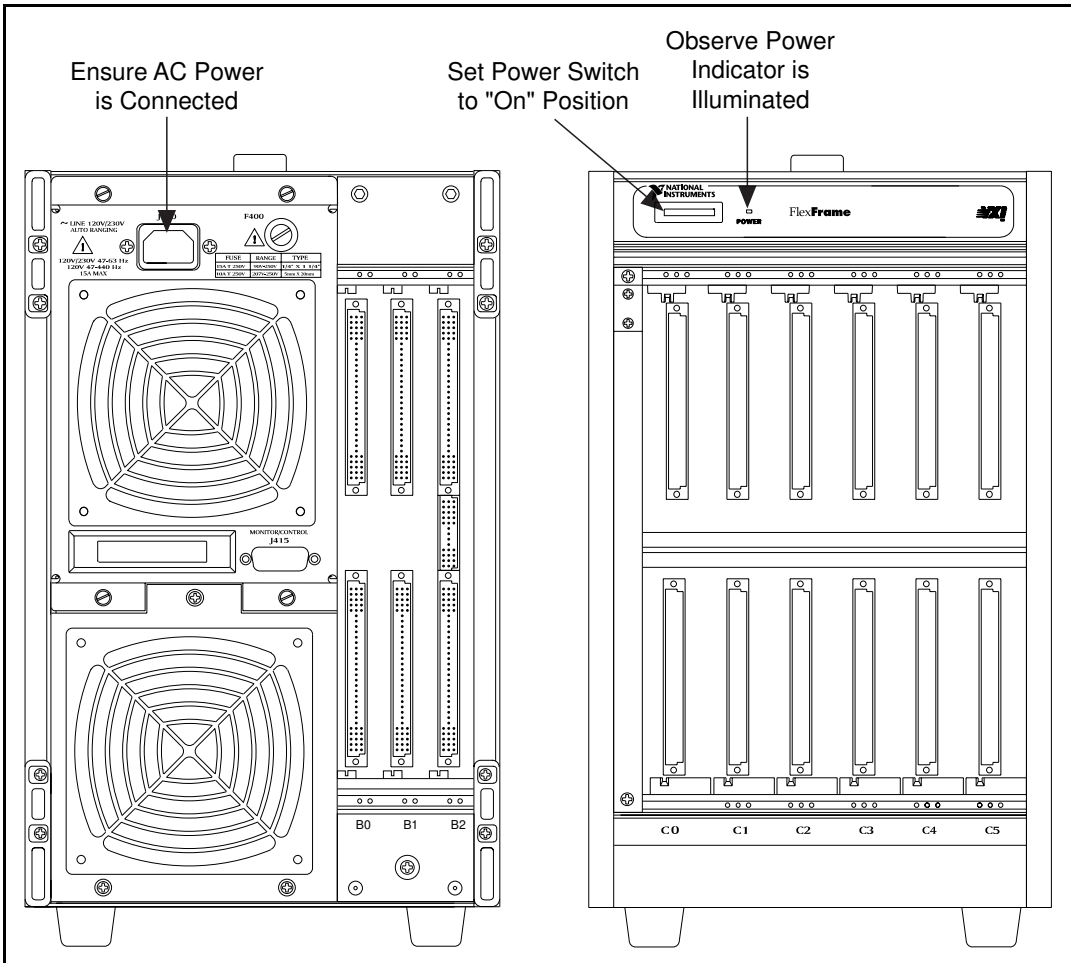
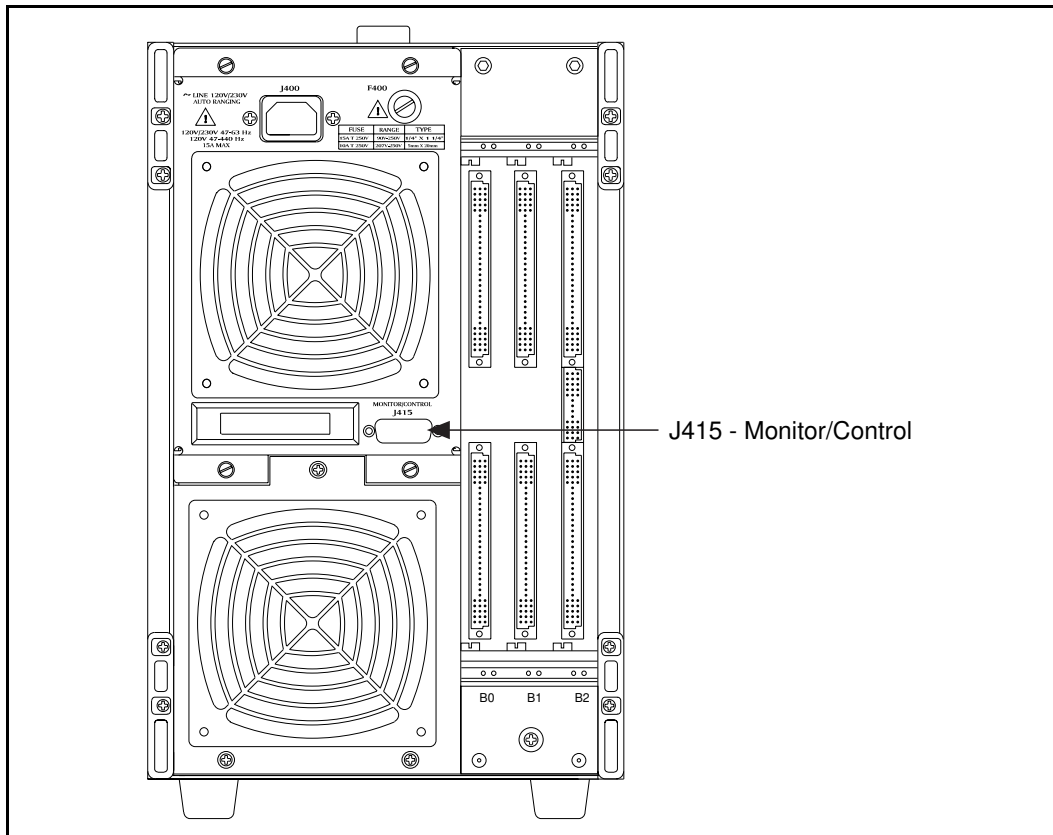

Figure 3-3. Powering on the Mainframe

# Using Remote Power On/Standby Switching

Find the Monitor/Control connector on the VXI-1200 at location J415 (see Figure 3-4).

Pin	Function
15	Remote INHIBIT*
7,11	Logic Ground (GND)



**Figure 3-4.** Using Remote Power On/Standby Switching

1. Connect a user-supplied cable (or equivalent) between J415 (female 15 DSUB) and either a remote switch or an open collector driver. The switch (or driver) should connect to J415 pin 15 (INHIBIT\*) and to one of the GND pins.
2. Complete the steps as shown in Figure 3-3.
3. Place in Standby state, with DC power to mainframe off, by closing the remote switch shorting pin J415-15 to logic ground (INHIBIT\* to GND) or by driving J415-15 to a TTL low state with an open collector driver that can sink 5 mA of current. The OC voltage at J415-15 is  $\leq 30$  VDC.
4. Open the remote switch or deassert the open collector driver to reapply DC power to the mainframe (power-on state). The front power switch should be in the On position.

## **Rear Panel Switch and Connector Descriptions**

---

You can use the Fan Full/Three Quarter Speed switch to adjust the speed of the fan between full speed and three-quarter speed. Refer to the *Fan Speed Range* section in Chapter 2, *Configuring the VXI-1200*.

Table 3-1 lists the signal assignments for the rear-panel Monitor/Control connector.

**Table 3-1.** J415 Rear-Panel Monitor/Control Connector

Pin	Signal	Description
1	-24 VMON	VXIbus Voltage Monitor Output
2	+12 VMON	VXIbus Voltage Monitor Output
3	+5 VMON	VXIbus Voltage Monitor Output
4	-5.2 VMON	VXIbus Voltage Monitor Output
5	+5 STANDBY	VXIbus +5 V Standby Input
6	ACFAIL*	VXIbus ACFAIL* Input or Monitor Output (see note following this table)
7	GND	Logic Ground
8	RSV	Reserved
9	+24 VMON	VXIbus Voltage Monitor Output
10	-12 VMON	VXIbus Voltage Monitor Output
11	GND	Logic Ground
12	-2V MON	VXIbus Voltage Monitor Output
13	+24VHS	+24 V House Keeping Supply Voltage Monitor Output
14	SYSRESET*	VXIbus SYSRESET* Input or Monitor Output (see note)
15	R INHIBIT*	Power Supply Remote Inhibit Input



**Note:** Refer to the VXIbus and VMEbus specifications for details on using the ACFAIL\* and SYSRESET\* signals. If you use these signals, do not violate the VXIbus or VMEbus electrical specifications.

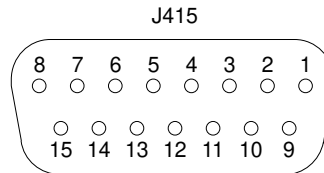

## Backplane Connections

---

Table 3-2 shows the P1 connector pinouts for all slots in the VXI-1200. Table 3-3 shows the P2 connector pinouts for all non-Slot 0 slots. Table 3-4 shows the P2 connector pinouts for the VXIbus Slot 0 located in either Slot C0 or Slot B0, depending on the personality module orientation (see the *VXIbus Slot 0 Controller Location* section in Chapter 2).

**Table 3-2.** P1 Connector Pinouts

<b>Pin</b>	<b>Row A</b>	<b>Row B</b>	<b>Row C</b>
1	D00	BBSY*	D08
2	D01	BCLR*	D09
3	D02	ACFAIL*	D10
4	D03	BG0IN*	D11
5	D04	BG0OUT*	D12
6	D05	BG1IN*	D13
7	D06	BG1OUT*	D14
8	D07	BG2IN*	D15
9	GND	BG2OUT*	GND
10	SYSCLK	BG3IN*	SYSFAIL*
11	GND	BG3OUT*	BERR*
12	DS1*	BR0*	SYSRESET*
13	DS0*	BR1*	LWORD*
14	WRITE*	BR2*	AM5
15	GND	BR3*	A23
16	DTACL*	AM0	A22
17	GND	AM1	A21
18	AS*	AM2	A20
19	GND	AM3	A19
20	IACK*	GND	A18
21	IACKIN*	SERCLK	A17
22	IACKOUT*	SERDAT*	A16
23	AM4	GND	A15
24	A07	IRQ7*	A14
25	A06	IRQ6*	A13
26	A05	IRQ5*	A12
27	A04	IRQ4*	A11
28	A03	IRQ3*	A10
29	A02	IRQ2*	A09
30	A01	IRQ1*	A08
31	-12 V	+5 V STDBY	+12 V
32	+5 V	+5 V	+5 V

**Table 3-3.** P2 Connector Pinouts for All Non-Slot 0 Locations

<b>Pin</b>	<b>Row A</b>	<b>Row B</b>	<b>Row C</b>
1	ECLTRG0	+5 V	CLK10+
2	-2 V	GND	CLK10-
3	ECLTRG1	RSV1	GND
4	GND	A24	-5.2 V
5	LBUSA00	A25	LBUSC00
6	LBUSA01	A26	LBUSC01
7	-5.2 V	A27	GND
8	LBUSA02	A28	LBUSC02
9	LBUSA03	A29	LBUSC03
10	GND	A30	GND
11	LBUSA04	A31	LBUSC04
12	LBUSA05	GND	LBUSC05
13	-5.2 V	+5 V	-2 V
14	LBUSA06	D16	LBUSC06
15	LBUSA07	D17	LBUSC07
16	GND	D18	GND
17	LBUSA08	D19	LBUSC08
18	LBUSA09	D20	LBUSC09
19	-5.2 V	D21	-5.2 V
20	LBUSA10	D22	LBUSC10
21	LBUSA11	D23	LBUSC11
22	GND	GND	GND
23	TTLTRG0*	D24	TTLTRG1*
24	TTLTRG2*	D25	TTLTRG3*
25	+5 V	D26	GND
26	TTLTRG4*	D27	TTLTRG5*
27	TTLTRG6*	D28	TTLTRG7*
28	GND	D29	GND
29	RSV2	D30	RSV3
30	MODID	D31	GND
31	GND	GND	+24 V
32	SUMBUS	+5 V	-24 V



**Table 3-4.** P2 Connector Pinouts for VXIbus Slot 0 (C0 or B0)

<b>Pin</b>	<b>Row A</b>	<b>Row B</b>	<b>Row C</b>
1	ECLTRG0	+5 V	CLK10+
2	-2 V	GND	CLK10-
3	ECLTRG1	RSV1	GND
4	GND	A24	-5.2 V
5	MODID12	A25	LBUSC00
6	MODID11	A26	LBUSC01
7	-5.2 V	A27	GND
8	MODID10	A28	LBUSC02
9	MODID09	A29	LBUSC03
10	GND	A30	GND
11	MODID08	A31	LBUSC04
12	MODID07	GND	LBUSC05
13	-5.2 V	+5 V	-2 V
14	MODID06	D16	LBUSC06
15	MODID05	D17	LBUSC07
16	GND	D18	GND
17	MODID04	D19	LBUSC08
18	MODID03	D20	LBUSC09
19	-5.2 V	D21	-5.2 V
20	MODID02	D22	LBUSC10
21	MODID01	D23	LBUSC11
22	GND	GND	GND
23	TTLTRG0*	D24	TTLTRG1*
24	TTLTRG2*	D25	TTLTRG3*
25	+5 V	D26	GND
26	TTLTRG4*	D27	TTLTRG5*
27	TTLTRG6*	D28	TTLTRG7*
28	GND	D29	GND
29	RSV2	D30	RSV3
30	MODID00	D31	GND
31	GND	GND	+24 V
32	SUMBUS	+5 V	-24 V

## Basic Functional Check

---

The functional check consists of checking the VXI-1200 power supply voltages to the VXIbus limits at the rear-panel connector J415 using a digital voltmeter.

Referring to Table 3-5, connect one lead of the voltmeter to a supply pin at J415. Connect the reference lead of the voltmeter to one of the ground pins. Compare each voltage reading to the values listed in Table 3-5.

**Table 3-5.** Power Supply Voltages at J415

J415 Pin	Supply	VXI Acceptable Voltage Range
3	+5 V	4.875 to 5.25 V
10	-12 V	-12.6 to 11.64 V
1	-24 V	-25.2 to -23.28 V
12	-2 V	-2.1 to -1.9 V
2	+12 V	11.64 to 12.6 V
9	+24 V	23.28 to 25.2 V
4	-5.2 V	-5.46 to -5.044 V
7,11	Logic Ground	—

If the voltages are within the specified ranges, the mainframe complies with VXI voltage limit specifications.

# Understanding the VXI-1200

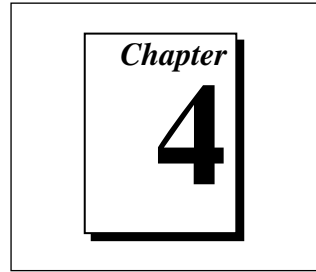

This chapter describes the major functional blocks of the VXI-1200 FlexFrame—the power supply, backplane, and cooling system.

Figure 4-1 shows the functional block diagram of the VXI-1200.

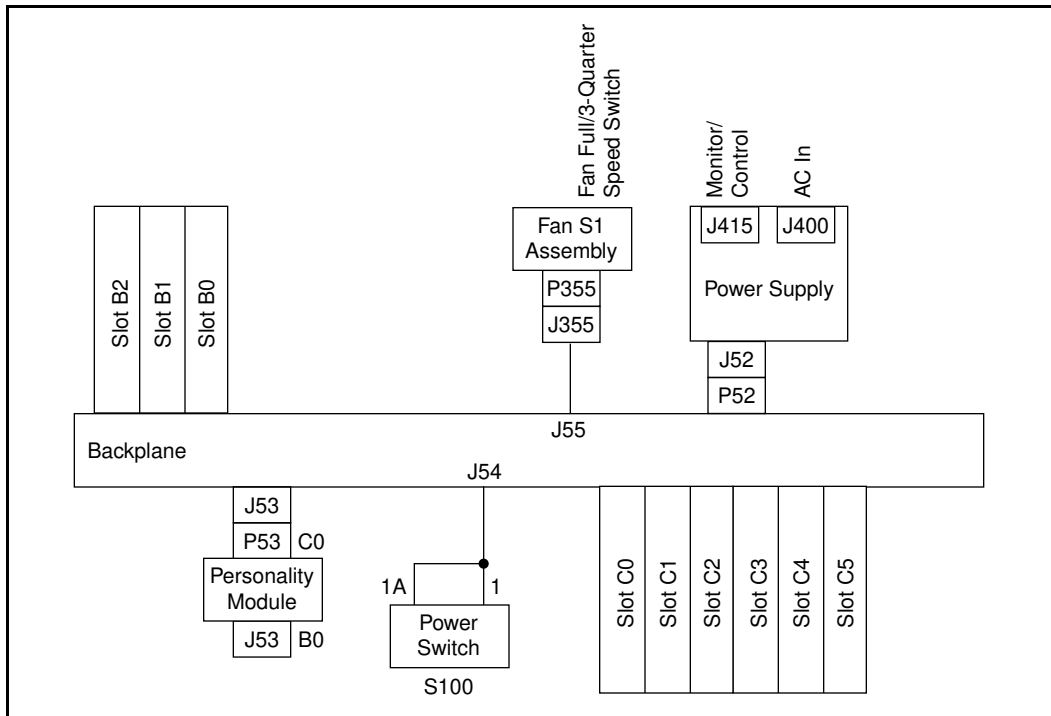

Figure 4-1. VXI-1200 Block Diagram

## Power Supply

---

The power supply accepts power from the AC mains and converts it to DC to power the following components.

- VXI modules installed into the backplane
- Backplane terminations and daisy-chaining logic
- Module cooling fans

## Power Supply Interconnection

Power is supplied to the backplane through board-to-board connector P52, eliminating any wiring and sub-backplane interconnect boards. This design reduces the path impedance between the supply and the VXI modules receiving power, which results in improved dynamic current performance. Refer to Appendix A, *Specifications*, for further details.

## Power Supply Protections

The seven VXIbus power supply outputs are protected for the following conditions.

- Over-voltage
- Over-current and short circuit

The AC input of the power supply includes protection for input current fusing.

See Appendix A, *Specifications*, for details pertaining to the above protections. If any of these protections are active, the power supply may shut down. This means it has, effectively, turned itself off to protect the system. The Power On/Standby switch or the Remote Inhibit input must be cycled to turn the mainframe back on. Refer to the *Powering on the Mainframe* and *Using Remote Power On/Standby Switching* sections in Chapter 3, *Operating the VXI-1200*.

# Backplane

---

The backplane serves several functions.

- Accommodates up to six C-size VXI modules and up to three B-size VXI or VME modules. The plug-in Personality module allows either the C0 slot or B0 slot to function as the mainframe VXIbus Slot 0 location.
- Accommodates a lifetime of insertions of VXI modules and the plug-in power supply.
- Supplies DC voltages and currents to modules.
- Connects the VME communications interface across P1 and P2 to all slots.
- Connects the VXI extensions across P2 rows a and c to all slots. There is no VXI local bus connection between B-size and C-size slots.
- Connects the Power On/Standby switch and module cooling fans with the power supply.

## Backplane Interconnections

The Power On/Standby switch (S100) connects to the backplane through a polarized locking wire-to-board header at J54.

The module cooling fans connect to the backplane through a polarized locking wire-to-board header at J56.

The power supply mates with the backplane through board-to-board connector J52.

## Cooling System

---

The module cooling fan is located at the bottom rear of the mainframe (bench-top configuration). In high ambient temperature conditions of  $\geq 40^{\circ}\text{C}$ , the fans should run at full speed.

Module cooling air enters at the rear of the rack-mounted VXI-1200 mainframe and is filtered as it is drawn through the fan chamber.

The incoming air is forced into a pressurized plenum below the VXI modules. The high pressure in the plenum forces the air through a metered plate into the P2 connector side of the VXI modules. The air passing over components in the modules absorbs heat and exits at the P1 side of the modules.

The VXI-1200 mainframe exhausts module cooling air at the top (bench-top configuration) or left side (rack-mount configuration) of the mainframe.

## Cooling the Power Supply

The power supply assembly contains a speed-controlled fan for its own internal cooling. Filtered air enters through the rear of the mainframe and exits at the top (bench-top) or side (rack-mount) after passing through the power supply.

# Maintenance

---

This chapter describes basic maintenance procedures you can perform on the VXI-1200 FlexFrame.

This chapter describes procedures for inspecting and cleaning the VXI-1200, removing and replacing mainframe components, and isolating problems to the module level. Refer to Chapter 4, *Understanding the VXI-1200*, for theory of operation information.

## Service Strategy

---

The service procedures in this manual describe removal and replacement procedures to repair the VXI-1200 to the module level. Module-level repairs are accomplished by exchanging faulty modules with known good modules or parts. No component-level repair is provided in this manual.

## Service Interval

---

Clean the power-supply filter and mainframe module fan filter at a maximum interval of six months. Depending upon the amount of use and ambient dust levels in the operating environment, the filters may require more frequent cleaning.

Clean dust from the mainframe exterior (and interior) as needed, based on the operating environment. Periodic cleaning reduces instrument breakdown and increases reliability.

## Preparation

---

The information in this section is designed for use by qualified service personnel. Read the *For Your Safety* section at the front of this manual and the *Service Strategy* section before attempting any procedures in this chapter. Refer to Chapter 3, *Operating the VXI-1200*, for information on the location of controls, indicators, and connectors used with the mainframe.



**Caution:** *Many components within the mainframe are susceptible to static discharge damage. Service the mainframe only in a static-free environment. Observe standard handling precautions for static-sensitive devices while servicing the mainframe. Always wear a grounded wrist strap, or equivalent, while servicing the mainframe.*

## Inspection and Cleaning

---

The mainframe is inspected mechanically and electrically before shipment. It should be free of marks or scratches and should meet or exceed all electrical specifications. To confirm this, inspect the mainframe for physical damage incurred during transit. Retain the mainframe packaging if reshipment is necessary.

Cleaning procedures consist of exterior and interior cleaning of the mainframe and cleaning the fan filters. Refer to your module user documentation for information on cleaning the individual VXIbus modules.



**Caution:** *Always power-off the mainframe and disconnect the power cord before cleaning or servicing the mainframe.*



## Interior Cleaning

Use a dry, low-velocity stream of air to clean the interior of the mainframe. Use a soft-bristle brush for cleaning around components. If you must use a liquid for minor interior cleaning, use a 75% isopropyl alcohol solution and rinse with deionized water.

## Exterior Cleaning

Clean the exterior surfaces of the mainframe with a dry lint-free cloth or a soft-bristle brush. If any dirt remains, wipe with a cloth moistened in a mild soap solution. Remove any soap residue by wiping with a cloth moistened with clear water. Do not use abrasive compounds on any part of the mainframe.



**Caution:** *Avoid getting moisture inside the mainframe during exterior cleaning. Use just enough moisture to dampen the cloth.*

*Do not wash the front- or rear-panel connectors or switches. Cover these components while cleaning the mainframe.*

*Do not use chemical cleaning agents; they may damage the mainframe. Avoid chemicals that contain benzene, toluene, xylene, acetone, or similar solvents.*

## Cleaning the Fan Filters

---

The module cooling filter or supply filter is easily removed from the rear of the mainframe as shown in Figure 5-1.

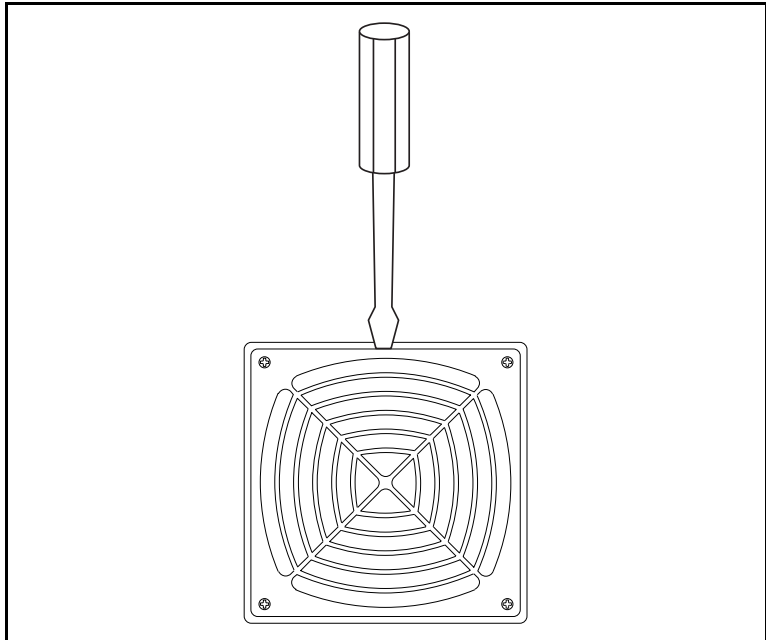

**Figure 5-1.** Cleaning the Fan Filters

1. Pry off the plastic grill retaining the supply fan filter. Use a flat-blade screwdriver if necessary.
2. Remove the supply fan filter toward the rear.
3. Clean the supply fan filter by washing in a mild soap solution, and then vacuuming or blowing air through the filter. Rinse the filter with water and allow to dry before replacing it in the mainframe.

# Removing and Replacing the AC Mains Fuse

Refer to Figure 5-2 as you complete the following steps.



**Warning:** *To avoid electrical shock, the AC mains power input must be disconnected before replacing the fuse.*

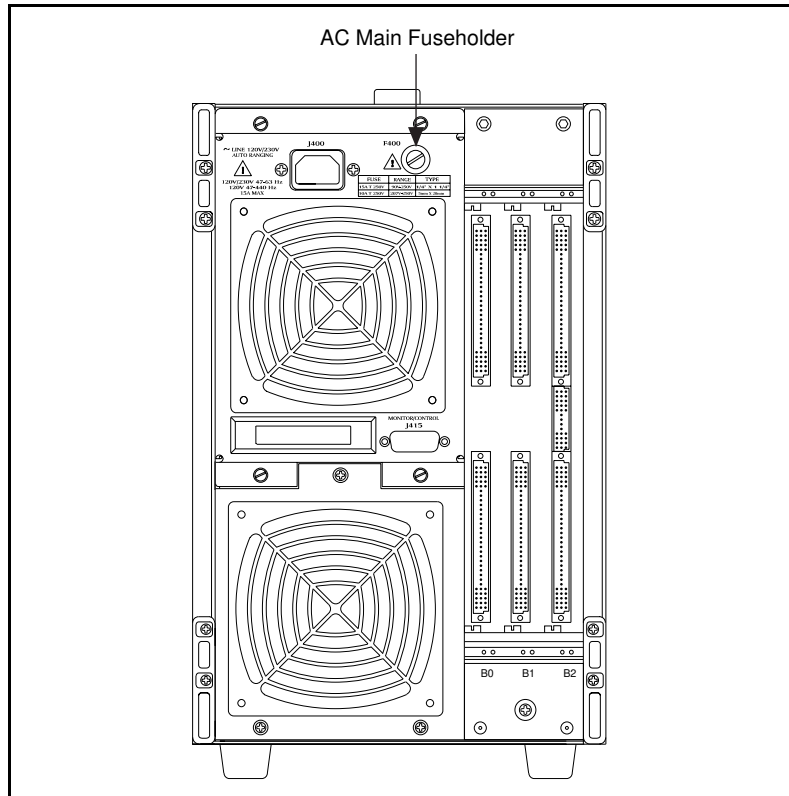

**Figure 5-2.** Removing and Replacing the AC Mains Fuse

1. Ensure that the AC mains input (J400) is disconnected.
2. Insert a flat-blade screwdriver into the fuse carrier slot at F400 in the power supply rear panel and rotate it counter-clockwise to remove.
3. To replace the fuse, insert the fuse carrier and fuse assembly into the fuse housing opening for F400 on the power supply.
4. Insert the flat-blade screwdriver into the fuse carrier and rotate it clockwise to lock the fuse assembly in place.

## Troubleshooting the VXI-1200

Refer to Table 5-1 to troubleshoot the VXI-1200 FlexFrame to its component module level. The table lists possible causes why the power annunciator does not come on and gives recommendations for correcting the problem. Also see Chapter 4, *Understanding the VXI-1200*.

**Table 5-1.** Troubleshooting

Possible Cause	What to Do
VXI-1200 mainframe not connected to power source.	Make sure that the VXI-1200 is connected to a live electrical outlet. Try operating another piece of equipment from this outlet.
Power/On/Standby switch not switched on.	Set the front Power On/Standby switch to the ON position (Refer to the <i>Powering on the Mainframe</i> section in Chapter 3).
Remote inhibit input on the rear panel of the power supply is active.	Remove the inhibit by opening the remote switch (or deasserting the remote open collector driver). (Refer to the <i>Using Remote Power On/Standby Switching</i> section in Chapter 3).
Blown AC mains fuse.	Unplug AC mains power and check the fuse. Refer to the <i>Removing and Replacing the AC Mains Fuse</i> section in this chapter.
Power supply protections are active, causing the supply to be shut down.	Refer to the <i>Power Supply Protections</i> section in Chapter 4. Cycle power to clear the fault. If the fault persists, remove installed VXI modules (cycle power) until the fault is cleared.

# Specifications

This appendix contains complete specifications for the VXI-1200.

## Electrical

### AC Input Specifications

Characteristic	Description
Input Voltage Range	90 to 250 V <sub>RMS</sub>
Input Frequency Range	47 to 440 Hz, 120 V operation 47 to 63 Hz, 230 V operation
Power Consumption	1440 W line power maximum
Fuse Rating	
90 to 250 V Operation	0.25 by 1.25 in., Slow Blow, 15 A, 250 V
207 to 250 V Operation	5 by 20 mm, Slow Blow, 10 A, 250 V
Inrush Current	40 A maximum, cold start or after one minute cool down
Input Current	15 A maximum at 90 V <sub>RMS</sub> 8 A maximum at 207 V <sub>RMS</sub>

Characteristic	Description
Power Disconnect	Front-panel Power On/Standby switch: Rear-panel connection allows for remote inhibit operation. Power cord provides main power disconnect. The Power On/Standby switch must be in Power On position prior to use of remote inhibit.
Power Factor Correction	Over entire input voltage range, 47 to 63 Hz

## DC Output Specifications

Characteristic	Description																		
Maximum Power Available to Modules	720 W, 0° to 50° C, 90 to 250 V, Derate 2.5% per ° C above 50° C																		
DC Current Capacity ( $I_{MP}$ )	<table> <thead> <tr> <th>Voltage</th> <th><math>I_{MP}</math> (Steady-State Current)</th> </tr> </thead> <tbody> <tr> <td>+24 V</td> <td>4 A</td> </tr> <tr> <td>+12 V</td> <td>8 A</td> </tr> <tr> <td>+5 V</td> <td>54 A</td> </tr> <tr> <td>-2 V</td> <td>12 A</td> </tr> <tr> <td>-5.2 V</td> <td>12 A</td> </tr> <tr> <td>-12 V</td> <td>8 A</td> </tr> <tr> <td>-24 V</td> <td>4 A</td> </tr> <tr> <td>+5 V STDBY</td> <td>0 A (1 A max, user supplied)</td> </tr> </tbody> </table>	Voltage	$I_{MP}$ (Steady-State Current)	+24 V	4 A	+12 V	8 A	+5 V	54 A	-2 V	12 A	-5.2 V	12 A	-12 V	8 A	-24 V	4 A	+5 V STDBY	0 A (1 A max, user supplied)
Voltage	$I_{MP}$ (Steady-State Current)																		
+24 V	4 A																		
+12 V	8 A																		
+5 V	54 A																		
-2 V	12 A																		
-5.2 V	12 A																		
-12 V	8 A																		
-24 V	4 A																		
+5 V STDBY	0 A (1 A max, user supplied)																		

Characteristic	Description	
DC Voltage Regulation	Voltage	Tolerance, $\Delta$ V +24 V +1.2 V, -720 mV +12 V +600 mV, -360 mV +5 V +250 mV, -125 mV -2 V -100 mV, +100 mV -5.2 V -260 mV, +156 mV -12 V -600 mV, +360 mV -24 V -1.2 V, +720 mV
Maximum Load Ripple/Noise	Voltage	Ripple/Noise +24 V 150 mV <sub>pp</sub> +12 V 50 mV <sub>pp</sub> +5 V 50 mV <sub>pp</sub> -2 V 50 mV <sub>pp</sub> -5.2 V 50 mV <sub>pp</sub> -12 V 50 mV <sub>pp</sub> -24 V 150 mV <sub>pp</sub>
Maximum Induced Ripple/Noise	Voltage	Ripple/Noise +24 V 150 mV <sub>pp</sub> +12 V 50 mV <sub>pp</sub> +5 V 50 mV <sub>pp</sub> -2 V 50 mV <sub>pp</sub> -5.2 V 50 mV <sub>pp</sub> -12 V 50 mV <sub>pp</sub> -24 V 150 mV <sub>pp</sub>
Auxiliary DC Outputs, Fused-Self Healing	Voltage	Current +5 V 1 A +12 V 1 A
Protections	Over-voltage protection Over-current protection	

Characteristic	Description																
VXI Supply Rear-Panel DC Voltage Monitors (J415 Connector)	<table> <tr> <td>Voltage</td> <td>Tolerance, <math>\Delta V</math></td> </tr> <tr> <td>+24 V</td> <td>+1.2 V, -720 mV</td> </tr> <tr> <td>+12 V</td> <td>+600 mV, -360 mV</td> </tr> <tr> <td>+5 V</td> <td>+250 mV, -125 mV</td> </tr> <tr> <td>-2 V</td> <td>-100 mV, +100 mV</td> </tr> <tr> <td>-5.2 V</td> <td>-260 mV, +156 mV</td> </tr> <tr> <td>-12 V</td> <td>-600 mV, +360 mV</td> </tr> <tr> <td>-24 V</td> <td>-1.2 V, +720 mV</td> </tr> </table>	Voltage	Tolerance, $\Delta V$	+24 V	+1.2 V, -720 mV	+12 V	+600 mV, -360 mV	+5 V	+250 mV, -125 mV	-2 V	-100 mV, +100 mV	-5.2 V	-260 mV, +156 mV	-12 V	-600 mV, +360 mV	-24 V	-1.2 V, +720 mV
Voltage	Tolerance, $\Delta V$																
+24 V	+1.2 V, -720 mV																
+12 V	+600 mV, -360 mV																
+5 V	+250 mV, -125 mV																
-2 V	-100 mV, +100 mV																
-5.2 V	-260 mV, +156 mV																
-12 V	-600 mV, +360 mV																
-24 V	-1.2 V, +720 mV																

## Cooling

Characteristic	Description
Per Slot Cooling Capacity	Typically 80 W per slot @ 0.35 mm H <sub>2</sub> O. Figure A-1 shows the worst-case slot-cooling curve of the mainframe.
Cooling System	Forced air circulation (positive pressurization)
Slot Airflow Direction	P2 to P1, bottom of module to the top of module
Mainframe Intake, Bench-Top	Bottom rear of mainframe
Mainframe Exhaust, Bench-Top	Top of mainframe
Mainframe Intake, Rack-Mount	Rear of mainframe
Mainframe Exhaust, Rack-Mount	Side of mainframe
Filter Access (Power Supply and Module Fans)	Filter accessible from rear of the mainframe



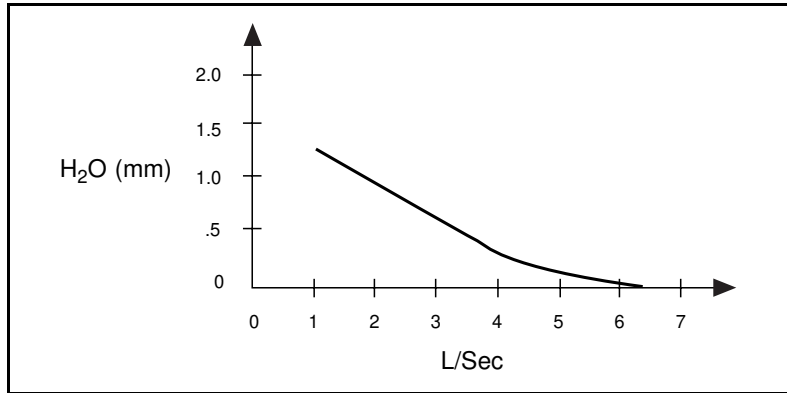

Figure A-1. Mainframe Worst-Case Slot-Cooling Curve

## Safety

Characteristic	Description
Safety Characteristics	EN61010-1
IEC Characteristics	Installation Category II Pollution Degree 2 Safety Class 1

# Environmental

Characteristic	Description																
Temperature	Meets the limits stated in MIL-T-28800E for Type III, Class 5																
Operating	0° to 55° C																
Non-operating	-40° to 71° C																
Relative Humidity (RH)																	
Operating	95 ± 5% RH noncondensing 75 ± 5% RH above 30° C 45 ± 5% RH above 40° C																
Non-operating	95 ± 5% RH at <55° C																
Altitude																	
Operating	4,570 m (10,000 ft.)																
Non-operating	12,190 m (15,000 ft.)																
Vibration	0.013 in. double amplitude, 5 to 55 Hz																
Functional Shock (Operating)	Half sine, 30 g, 11 ms duration.																
EMI	FCC Class A Verified, EC Certified																
Immunity, Enclosure, Radio Frequency Electromagnetic Field	No mainframe failures when the mainframe is subjected to a 3 V/m electromagnetic field over the frequency range of 27 to 500 MHz																
Immunity, Enclosure, Electrostatic Discharge (ESD)	Up to 8 kV with no change to control settings or impairment of normal operation																
Immunity, Fast Transients, Common Mode	<table border="1"> <thead> <tr> <th>Port</th> <th>Peak Voltage</th> <th>Tr/Th</th> <th>Rep Freq.</th> </tr> </thead> <tbody> <tr> <td>Signal&amp;Control</td> <td>0.5 kV</td> <td>5/50 ns</td> <td>5 kHz</td> </tr> <tr> <td>DC Power</td> <td>0.5 kV</td> <td>5/50 ns</td> <td>5 kHz</td> </tr> <tr> <td>AC Power</td> <td>1.0 kV</td> <td>5/50 ns</td> <td>5 kHz</td> </tr> </tbody> </table>	Port	Peak Voltage	Tr/Th	Rep Freq.	Signal&Control	0.5 kV	5/50 ns	5 kHz	DC Power	0.5 kV	5/50 ns	5 kHz	AC Power	1.0 kV	5/50 ns	5 kHz
Port	Peak Voltage	Tr/Th	Rep Freq.														
Signal&Control	0.5 kV	5/50 ns	5 kHz														
DC Power	0.5 kV	5/50 ns	5 kHz														
AC Power	1.0 kV	5/50 ns	5 kHz														

## Backplane

---

Characteristic	Description
Bus Grant/Interrupt Acknowledge	Solid state, auto-configuring (jumperless)
VXIbus CLK10 Distribution	Full differential

## Physical

---

Characteristic	Description
Overall Dimensions	
Standard Mainframe (7U)	
Height	35.6 cm (14.02 in.)
Width	22.2 cm (8.72 in.)
Depth	71.9 cm (28.32 in.)
Weight	15.9 kg (35 lb.) with no modules installed
MTBF	44,554.76 hours

# Customer Communication

---

For your convenience, this appendix contains forms to help you gather the information necessary to help us solve technical problems you might have as well as a form you can use to comment on the product documentation. Filling out a copy of the *Technical Support Form* before contacting National Instruments helps us help you better and faster.

National Instruments provides comprehensive technical assistance around the world. In the U.S. and Canada, applications engineers are available Monday through Friday from 8:00 a.m. to 6:00 p.m. (central time). In other countries, contact the nearest branch office. You may fax questions to us at any time.

## Electronic Services



### Bulletin Board Support

National Instruments has BBS and FTP sites dedicated for 24-hour support with a collection of files and documents to answer most common customer questions. From these sites, you can also download the latest instrument drivers, updates, and example programs. For recorded instructions on how to use the bulletin board and FTP services and for BBS automated information, call (512) 795-6990. You can access these services at:

United States: (512) 794-5422

Up to 14,400 baud, 8 data bits, 1 stop bit, no parity

United Kingdom: 01635 551422

Up to 9,600 baud, 8 data bits, 1 stop bit, no parity

France: 1 48 65 15 59

Up to 9,600 baud, 8 data bits, 1 stop bit, no parity



### FTP Support

To access our FTP site, log on to our Internet host, `ftp.natinst.com`, as `anonymous` and use your Internet address, such as `joesmith@anywhere.com`, as your password. The support files and documents are located in the `/support` directories.



## Fax-on-Demand Support

Fax-on-Demand is a 24-hour information retrieval system containing a library of documents on a wide range of technical information. You can access Fax-on-Demand from a touch-tone telephone at (512) 418-1111



## E-Mail Support (currently U.S. only)

You can submit technical support questions to the appropriate applications engineering team through e-mail at the Internet addresses listed below. Remember to include your name, address, and phone number so we can contact you with solutions and suggestions.

support@natinst.com

## Telephone and Fax Support

National Instruments has branch offices all over the world. Use the list below to find the technical support number for your country. If there is no National Instruments office in your country, contact the source from which you purchased your software to obtain support.



### Telephone

Australia	02 9874 4100
Austria	0662 45 79 90 0
Belgium	02 757 00 20
Canada (Ontario)	905 785 0085
Canada (Quebec)	514 694 8521
Denmark	45 76 26 00
Finland	90 527 2321
France	01 48 14 24 24
Germany	089 741 31 30
Hong Kong	2645 3186
Israel	03 5734815
Italy	02 413091
Japan	03 5472 2970
Korea	02 596 7456
Mexico	5 520 2635
Netherlands	0348 433466
Norway	32 84 84 00
Singapore	2265886
Spain	91 640 0085
Sweden	08 730 49 70
Switzerland	056 200 51 51
Taiwan	02 377 1200
U.K.	01635 523545



### Fax

02 9874 4455
0662 45 79 90 19
02 757 03 11
905 785 0086
514 694 4399
45 76 26 02
90 502 2930
01 48 14 24 14
089 714 60 35
2686 8505
03 5734816
02 41309215
03 5472 2977
02 596 7455
5 520 3282
0348 430673
32 84 86 00
2265887
91 640 0533
08 730 43 70
056 200 51 55
02 737 4644
01635 523154

# Technical Support Form

Photocopy this form and update it each time you make changes to your software or hardware, and use the completed copy of this form as a reference for your current configuration. Completing this form accurately before contacting National Instruments for technical support helps our applications engineers answer your questions more efficiently.

If you are using any National Instruments hardware or software products related to this problem, include the configuration forms from their user manuals. Include additional pages if necessary.

Name \_\_\_\_\_

Company \_\_\_\_\_

Address \_\_\_\_\_

\_\_\_\_\_

Fax ( \_\_\_\_ ) \_\_\_\_\_ Phone ( \_\_\_\_ ) \_\_\_\_\_

Computer brand \_\_\_\_\_ Model \_\_\_\_\_ Processor \_\_\_\_\_

Operating system (include version number \_\_\_\_\_

Clock Speed \_\_\_\_\_MHz RAM \_\_\_\_\_MB Display adapter \_\_\_\_\_

Mouse \_\_\_\_\_yes \_\_\_\_\_no Other adapters installed \_\_\_\_\_

Hard disk capacity \_\_\_\_\_MB Brand \_\_\_\_\_

Instruments used \_\_\_\_\_

National Instruments hardware product model \_\_\_\_\_ Revision \_\_\_\_\_

Configuration \_\_\_\_\_

National Instruments software product \_\_\_\_\_ Version \_\_\_\_\_

Configuration \_\_\_\_\_

The problem is \_\_\_\_\_

\_\_\_\_\_

\_\_\_\_\_

List any error messages \_\_\_\_\_

\_\_\_\_\_

\_\_\_\_\_

The following steps will reproduce the problem \_\_\_\_\_

\_\_\_\_\_

\_\_\_\_\_

# Hardware and Software Configuration Form

Record the settings and revisions of your hardware and software on the line to the right of each item. Complete a new copy of this form each time you revise your software or hardware configuration, and use this form as a reference for your current configuration. Completing this form accurately before contacting National Instruments for technical support helps our applications engineers answer your questions more efficiently.

## National Instruments Products

Complete Part Number \_\_\_\_\_

Serial Number \_\_\_\_\_

Line Voltage \_\_\_\_\_

Personality Module Orientation (C0 or B0 slot) \_\_\_\_\_

Fan Speed \_\_\_\_\_

Safety Ground Connected? \_\_\_\_\_

Rack-mount or Bench-top Configuration? \_\_\_\_\_

Airflow Directors Installed \_\_\_\_\_

## Other Products

Computer Make and Model \_\_\_\_\_

Microprocessor \_\_\_\_\_

Clock Frequency \_\_\_\_\_

Operating System \_\_\_\_\_

Slot	Logical Address	Interrupt Level	Manufacturer, Description, and Function
C0			
C1			
C2			
C3			
C5			
C5			
B0			
B1			
B2			

# Documentation Comment Form

National Instruments encourages you to comment on the documentation supplied with our products. This information helps us provide quality products to meet your needs.

**Title:** *VXI-1200 User Manual*

**Edition Date:** December 1996

**Part Number:** 321404A-01

Please comment on the completeness, clarity, and organization of the manual.

---

---

---

---

---

---

---

---

If you find errors in the manual, please record the page numbers and describe the errors.

---

---

---

---

---

---

---

---

Thank you for your help.

Name \_\_\_\_\_

Title \_\_\_\_\_

Company \_\_\_\_\_

Address \_\_\_\_\_

Phone ( \_\_\_\_\_ ) \_\_\_\_\_

**Mail to:** Technical Publications  
National Instruments Corporation  
6504 Bridge Point Parkway  
Austin, TX 78730-5039

**Fax to:** Technical Publications  
National Instruments Corporation  
(512) 794-5678



<b>Prefix</b>	<b>Meaning</b>	<b>Value</b>
n-	nano-	$10^{-9}$
m-	milli-	$10^{-3}$
c-	centi-	$10^{-2}$
k-	kilo-	$10^3$
M-	mega-	$10^6$

## **Symbols**

°	degrees
≥	equal or greater than
≤	equal or less than
Δ V	change in voltage
%	per cent

## **A**

A	amperes
AC	alternating current

**ACFAIL** A VME backplane signal that is asserted when a power failure has occurred (either AC line source or power supply malfunction), or if it is necessary to disable the power supply (such as for a high temperature condition).

**ASFP** application-specific front panel

**AWG** American Wire Gauge

## **B**

**backplane** An assembly, typically a printed circuit board, with 96-pin connectors and signal paths that bus the connector pins. A C-size VXIbus system will have two sets of bused connectors called J1 and J2.

**BERR** Bus error; an error that signals failed access to an address. Bus errors occur with low-level accesses to memory and usually involve hardware with bus mapping capabilities. For example, nonexistent memory, a nonexistent register, or an incorrect device access can cause a bus error.

## **C**

**C** Celsius

**CLK10** A 10 MHz,  $\pm 100$  ppm, individually buffered (to each module slot), differential ECL system clock that is sourced from Slot 0 of a VXIbus mainframe and distributed to Slots 1 through 12 on P2. It is distributed to each slot as a single-source, single-destination signal with a matched delay of under 8 ns.

## **D**

**daisy-chain** A method of propagating signals along a bus, in which the devices are prioritized on the basis of their position on the bus.

**DC** direct current

**E**

ECL emitter-coupled logic

ESD electrostatic discharge

**F**

ft. feet

**G**

GND ground

**H**

Hz hertz; cycles per second

**I**

IACK interrupt acknowledge

IEC International Electrotechnical Commission; an organization that sets international electrical and electronics standards.

$I_{MP}$  mainframe peak current

in. inches

**L**

lb. pounds

LED light-emitting diode

## **M**

m	meters
MODID	module identification lines
MTBF	mean time between failure
MTTR	mean time to repair

## **O**

OC	open collector
----	----------------

## **R**

RH	relative humidity
RMS	root mean square; a method used to measure electrical output in volts and watts.

## **S**

s	seconds
Slot 0 module	A device configured for installation in Slot 0 of a VXIbus mainframe. This device is unique in the VXIbus system in that it performs the VMEbus system controller functions, including clock sourcing and arbitration for data transfers across the backplane. Installing such a device into any other slot can damage the device, the VXIbus backplane, or both.
SYSFAIL	A VMEbus signal that is used by a device to indicate an internal failure. A failed device asserts this line.
SYSRESET	A VMEbus signal that is used by a device to indicate a system reset or power-up condition.

## T

Tr/Th	rise time/hold time
TTL	transistor-transistor logic

## U

U	Eurocard size
---	---------------

## V

V	volts
VAC	volts alternating current
VDC	volts direct current
VME	Versa Module Eurocard or IEEE 1014
$V_{pp}$	volts peak-to-peak
VXI	VMEbus Extensions for Instrumentation

## W

W	watts
---	-------

## Numbers

- 2 VMON signal (table), 3-6
- +5 STANDBY signal (table), 3-6
- +5 VMON signal (table), 3-6
- 5.2 VMON signal (table), 3-6
- +12 VMON signal (table), 3-6
- 12 VMON signal (table), 3-6
- +24 VHS signal (table), 3-6
- +24 VMON signal (table), 3-6
- 24 VMON signal (table), 3-6

## A

- AC mains power
  - operating at greater than 63 Hz (warning), 2-1
  - overview, 2-1
  - removing and replacing fuse, 5-5
  - troubleshooting, 5-6
- ACFAIL\* signal (table), 3-6
- airflow directors, installing and removing, 2-4
- Application-Specific Front Panel (ASFP), installing, 2-6

## B

- backplane
  - features, 1-10
  - functions, 4-3
  - interconnections, 4-3
  - specifications, A-7

## backplane connections

- P1 connector pinouts (table), 3-8
- P2 connector pinouts
  - all non-Slot 0 locations (table), 3-9
  - VXIbus Slot 0 (table), 3-10
- bench-top cooling system, 1-8
- bench-top mainframe, portable, 1-3
- B-sized VXI/VME modules, slot locations, 1-4
- bulletin board support, B-1

## C

- card guide covers, installing and removing, 2-4
- cleaning the VXI-1200, 5-2 to 5-3
  - exterior, 5-3
  - fan filters, 5-4
  - interior, 5-3
  - precautions, 5-3
- configuration and installation, 2-1 to 2-9
  - AC mains power, 2-1
  - ASFP panel, 2-6
  - card guide covers (airflow directors), 2-4
  - fan speed range, 2-9
  - fast setup features, 1-2
  - filler panels, 2-6
  - module installation, 2-3 to 2-4
  - rack-mount door, 2-7
  - safety ground connection, 2-8
  - site considerations, 2-2
  - VXIbus Slot 0 controller location, 2-2

cooling system

- bench-top cooling system, 1-8
- cleaning fan filters, 5-4
- fan speed range selection, 2-9
- operation, 4-4
- overview, 1-2
- power supply cooling, 4-4
- rack-mount cooling system, 1-9
- specifications, A-4 to A-5

customer communication, *xii*, B-1 to B-2

**D**

documentation

- conventions used in manual, *xii*
- organization of manual, *xi-xii*

**E**

electrical specifications, A-1 to A-4

- AC input, A-1 to A-2
- DC output, A-2 to A-4

electronic support services, B-1 to B-2

e-mail support, B-2

environmental specifications, A-6

equipment, optional, 1-1

**F**

fan filters, cleaning, 5-4

fan speed range selection, 2-9

Fax-on-Demand support, B-2

filler panels, installing, 2-6

FTP support, B-1

functional check, 3-11

fuse for AC mains

- blown fuse (table), 5-6
- removing and replacing, 5-5

**G**

GND signal (table), 3-6

ground, connecting, 2-8

**I**

inspection of VXI-1200, 5-2  
installation. *See* configuration  
and installation.

**J**

J415 Monitor/Control connector

- basic functional check, 3-11
- location on VXI-1200 (figure), 3-4
- power supply voltages (table), 3-11
- rear panel
  - illustration, 3-6
  - signal assignments (table), 3-6
- remote power on/standby switching, 3-4  
to 3-5

**M**

mainframe

- modular design, 1-6
- portable bench-top, 1-3
- powering on, 3-3

maintenance of VXI-1200, 5-1 to 5-6

- AC mains fuse, removing and  
replacing, 5-5
- cleaning, 5-2 to 5-3
  - exterior, 5-3
  - interior, 5-3
  - precautions, 5-3
- fan filters, cleaning, 5-4
- inspection, 5-2
- preparation, 5-2
- service interval, 5-1
- service strategy, 5-1
- static discharge damage (caution), 5-2
- troubleshooting, 5-6

manual. *See* documentation.

Monitor/Control connector. *See*

J415Monitor/Control connector.

**N**

non-Slot 0 locations, P2 connector pinouts (table), 3-9

**O**

operating the VXI-1200, 3-1 to 3-11
 

- backplane connections, 3-7 to 3-10
  - P1 connector pinouts (table), 3-8
  - P2 connector pinouts, non-Slot 0 locations (table), 3-9
  - P2 connector pinouts, VXIbus Slot 0 locations (table), 3-10
- basic functional check, 3-11
- front view of VXI-1200 (figure), 3-1
- powering on mainframe, 3-3
- rear panel switch and connector
  - descriptions, 3-5 to 3-6
- rear view of VXI-1200 (figure), 3-1
- remote power on/standby switching, 3-4 to 3-5

**P**

P1 connector pinouts (table), 3-8  
 P2 connector pinouts
 

- all non-Slot 0 locations (table), 3-9
- VXIbus Slot 0 (table), 3-10

 Personality module, plug-in, 1-2  
 physical specifications, A-7  
 plug-in Personality module, 1-2  
 portable bench-top mainframe, 1-3  
 power on/standby switching, remote, 3-4 to 3-5  
 power supply
 

- 720 watt plug-in power supply
  - available DC current (table), 1-7
  - illustration, 1-7
- AC mains power, 2-1
- cooling, 4-4
- electrical specifications, A-1 to A-4

- AC input, A-1 to A-2
- DC output, A-2 to A-4
- interconnections, 4-2
- overview, 4-2
- plug-in power supply, fans, and monitor, 1-2
- protections, 4-2
- troubleshooting, 5-6
- universal AC input, 1-2
- voltages at J415 Monitor/Control connector (table), 3-11

powering on mainframe, 3-3

**R**

R INHIBIT\* signal (table), 3-6  
 rack-mounting
 

- configuration (5U footprint), 1-5
- installing rack-mount door, 2-7
- options, 1-10
- overview, 1-2
- rack-mount cooling system, 1-9

 rear panel
 

- illustration, 3-2
- signal assignments (table), 3-6
- switch and connector descriptions, 3-5 to 3-6

 remote power on/standby switching, 3-4 to 3-5  
 requirements for getting started, 1-1  
 RSV signal (table), 3-6

**S**

safety ground, connecting, 2-8  
 safety specifications, A-5  
 signal assignments, J415 rear-panel Monitor/Control connector (table), 3-6  
 Slot 0
 

- P2 connector pinouts
  - all non-Slot 0 locations (table), 3-9
  - VXIbus Slot 0 (table), 3-10
- VXIbus controller location, 2-2

 slot locations for B-sized VXI/VME modules, 1-4



specifications

- backplane, A-7
- cooling, A-4 to A-5
- electrical, A-1 to A-4
  - AC input, A-1 to A-2
  - DC output, A-2 to A-4
- environmental, A-6
- physical, A-7
- safety, A-5

standby switching, 3-4 to 3-5

SYSRESET\* signal (table), 3-6

- installation, 2-3
- slot locations, 1-4
- C-sized
  - installation, 2-3

## T

technical support, B-1 to B-2

telephone and fax support, B-2

troubleshooting the VXI-1200, 5-6

## V

VXI-1200. *See also* specific components,

e.g., power supply.

block diagram, 4-1

ease of use, 1-2

features, 1-1 to 1-5

front view (figure), 3-1

optional equipment, 1-1

overview

backplane, 1-10

cooling system, 1-8 to 1-9

modular mainframe design, 1-6

plug-in power supply, 1-7

portable bench-top mainframe, 1-3

rack-mount configuration (5U footprint), 1-5

rack-mount options, 1-10

slot locations for B-sized

VXI/VME modules, 1-4

rear view (figure), 3-1

requirements for getting started, 1-1

VXIbus Slot 0

controller location, 2-2

P2 connector pinouts (table), 3-10

VXI/VME modules

B-sized