

COMPREHENSIVE SERVICES

We offer competitive repair and calibration services, as well as easily accessible documentation and free downloadable resources.

SELL YOUR SURPLUS

We buy new, used, decommissioned, and surplus parts from every NI series. We work out the best solution to suit your individual needs.

 Sell For Cash  Get Credit  Receive a Trade-In Deal

OBSOLETE NI HARDWARE IN STOCK & READY TO SHIP

We stock **New**, **New Surplus**, **Refurbished**, and **Reconditioned** NI Hardware.



Bridging the gap between the manufacturer and your legacy test system.

 1-800-915-6216

 www.apexwaves.com

 sales@apexwaves.com

All trademarks, brands, and brand names are the property of their respective owners.

Request a Quote

 **CLICK HERE**

PXI-1000B

ADDITIONAL INFORMATION ABOUT YOUR PXI™-1000B

The following information was compiled after publication of the *PXI-1000B User Manual*. Please read this note carefully and refer to it in conjunction with your *PXI-1000B User Manual*.

Replacing the Power Supply Fuse (AC-Only Chassis)

The PXI-1000B AC-only chassis has a fuse inside the power supply module for additional protection beyond the external AC mains circuit breaker. Complete the following steps to replace the 250 V, 12 A NB (normal blow) fuse, as shown in Figure 1:

1. Turn the power switch to the Standby position.
2. Disconnect the AC line cord.
3. Loosen the six captive screws in the back of the chassis, as shown in Figure 2.
4. Grasp the handles of the power supply module and remove it from the back of the chassis.
5. Replace the fuse.
6. Reinstall the power supply module in the chassis.
7. Tighten the six captive screws.
8. Reconnect the AC line cord.

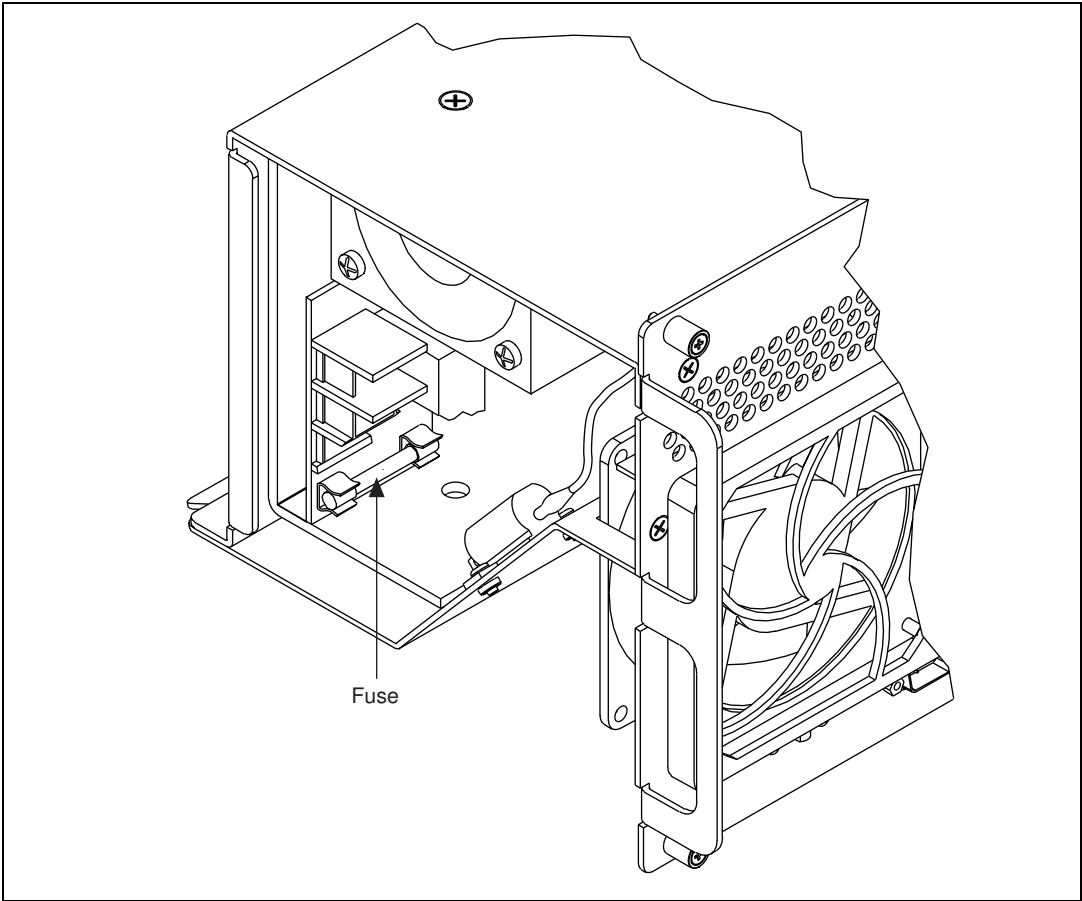

Figure 1. Power Supply Module

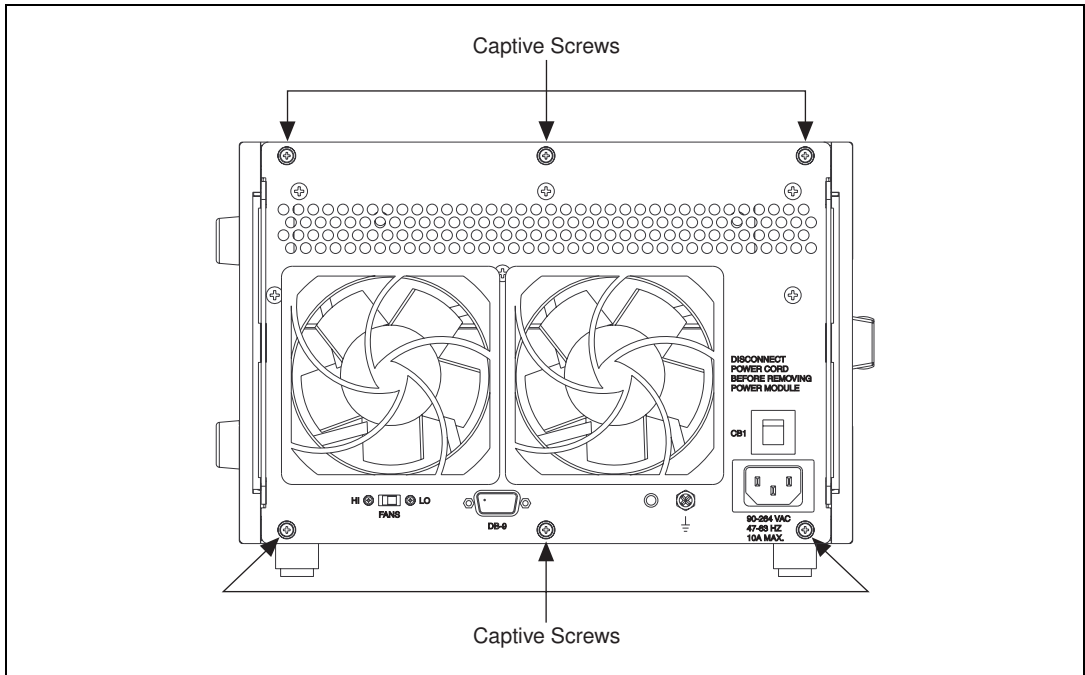

Figure 2. Captive Screws Holding the Power Supply Module

AC Power Cord Compliance

AC mains supply cords used with the PXI-1000B must meet the requirements of ANSI/UL817 for use in the United States, CSA C22.2 21 and 49 for use in Canada, and IEC 227 or 245 for use in the European Union. AC mains power supply cords used with the PXI-1000B in other countries must be approved by the authority having jurisdiction in that country.

Replacing the Fuse for Optional Battery Pack (DC-Capable Chassis Only)

The optional battery pack for the DC-capable PXI-1000B has a 10 A inline automotive-type fuse. Complete the following steps to replace the fuse, as shown in Figure 3:

1. Turn the power switch to the Standby position.
2. Disconnect the AC line cord and DC power cable.
3. Loosen the six captive screws in the back of the chassis, as shown in Figure 2.
4. Grasp the handles of the power supply module and remove it from the back of the chassis.
5. Replace the battery pack fuse.
6. Reinstall the power supply module in the chassis.
7. Tighten the six captive screws.
8. Reconnect the AC line cord and DC power cable, if previously connected.

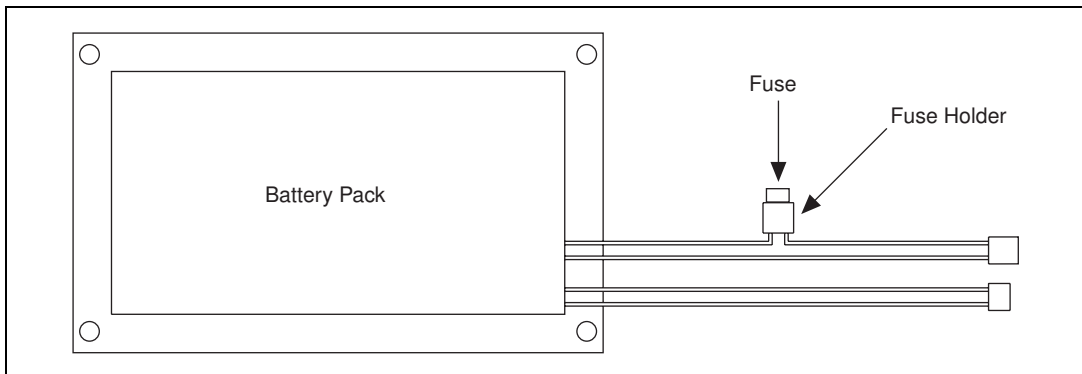

Figure 3. Optional Battery Pack

DC Connector (DC-Capable Chassis Only)

Figure 4 shows the DC connector (P1) on the rear panel of the DC-capable PXI-1000B.

If you want to build a custom DC cable, be sure to note the positive (+) and negative (–) terminals shown in Figure 4. Use the following components or their equivalents to mate to the P1 port:

- Positronic connector, part number CBD7W2F20000
- Norcomp hood, part number 972-015-010-011
- Two Positronic contacts, part number FS4008D

Install a 20 A inline fuse on the positive (+) wire of the custom cable.



Note You can purchase an optional DC cable from National Instruments that incorporates an inline fuse and the mating connector for the P1 port.

Figure 4 details the P1 connector on the chassis, *not* the cable.

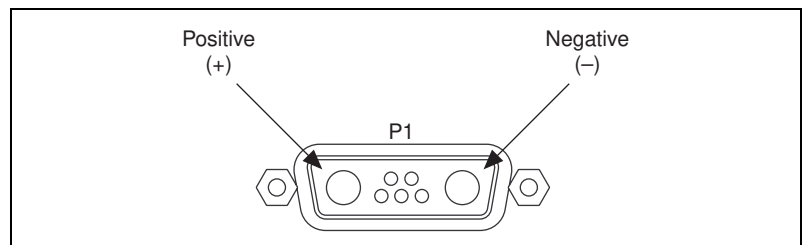

Figure 4. DC Connector on Rear of DC-Capable PXI-1000B Chassis



322512B-01

Jul99