

COMPREHENSIVE SERVICES

We offer competitive repair and calibration services, as well as easily accessible documentation and free downloadable resources.

SELL YOUR SURPLUS

We buy new, used, decommissioned, and surplus parts from every NI series. We work out the best solution to suit your individual needs.

 Sell For Cash  Get Credit  Receive a Trade-In Deal

OBSOLETE NI HARDWARE IN STOCK & READY TO SHIP

We stock **New**, **New Surplus**, **Refurbished**, and **Reconditioned** NI Hardware.



Bridging the gap between the manufacturer and your legacy test system.

 1-800-915-6216

 www.apexwaves.com

 sales@apexwaves.com

All trademarks, brands, and brand names are the property of their respective owners.

Request a Quote

 **CLICK HERE**

SCXI-1314

SCXI™-1314 UNIVERSAL STRAIN TERMINAL BLOCK

This guide describes how to install and use the SCXI-1314 terminal block with your SCXI-1520 module.

Introduction

The SCXI-1314 terminal block is used with the SCXI-1520 universal strain/bridge module enabling you to conveniently connect strain gauges through screw terminals. There are 88 screw terminals arranged in eight groups of 11. Each group corresponds to one of the eight channels available on the SCXI-1520. (Refer to Figure 2 for a diagram of terminal locations.) The signal names of the terminals for each channel are listed in Table 1.

Table 1. Signal Names

Signal Name	Condition
P+	Positive excitation signal
P-	Negative excitation signal
S+	Positive input signal
S-	Negative input signal
QTR	Quarter-bridge completion resistor connection
RS+	Positive remote sense signal
RS-	Negative remote sense signal
SCA (2 terminals)	Shunt calibration A signal
SCB (2 terminals)	Shunt calibration B signal

Each channel input contains screw terminals that connect to the inputs of the SCXI-1520, two precision 100 k Ω shunt calibration resistors, and a precision quarter-bridge completion resistor. The SCXI-1520 contains

relays that switch the resistors in and out of the input circuit to provide shunt calibration and quarter-bridge completion.

The quarter-bridge completion resistor has a factory default value of 350 Ω for use with a 350 Ω strain gauge. These resistors are placed in sockets on the terminal block so you can easily replace them with resistors suitable to your specific strain gauge. If your application requires a 120 Ω strain gauge, use the eight 120 Ω resistors included in the kit.

For a complete description of the use and operation of the SCXI-1520 module, refer to the *SCXI-1520 User Manual*.

What You Need to Get Started

To install and use your SCXI-1314 terminal block, you need the following items:

- SCXI-1314 terminal block
- [*SCXI-1314 Universal Strain Terminal Block Installation Guide*](#)
- Eight precision 120 Ω resistors for use in quarter-bridge completion circuits (if using 120 Ω strain gauges)
- SCXI chassis
- SCXI-1520 module
- SCXI-1520 User Manual*
- Number 1 and 2 Phillips-head screwdrivers
- 1/8 in. flathead screwdriver
- Long-nose pliers
- Wire cutter
- Wire insulation stripper

Connecting the Signals

To connect the signal to the terminal block, perform the following steps, referring to Figures 1 and 2 as necessary:

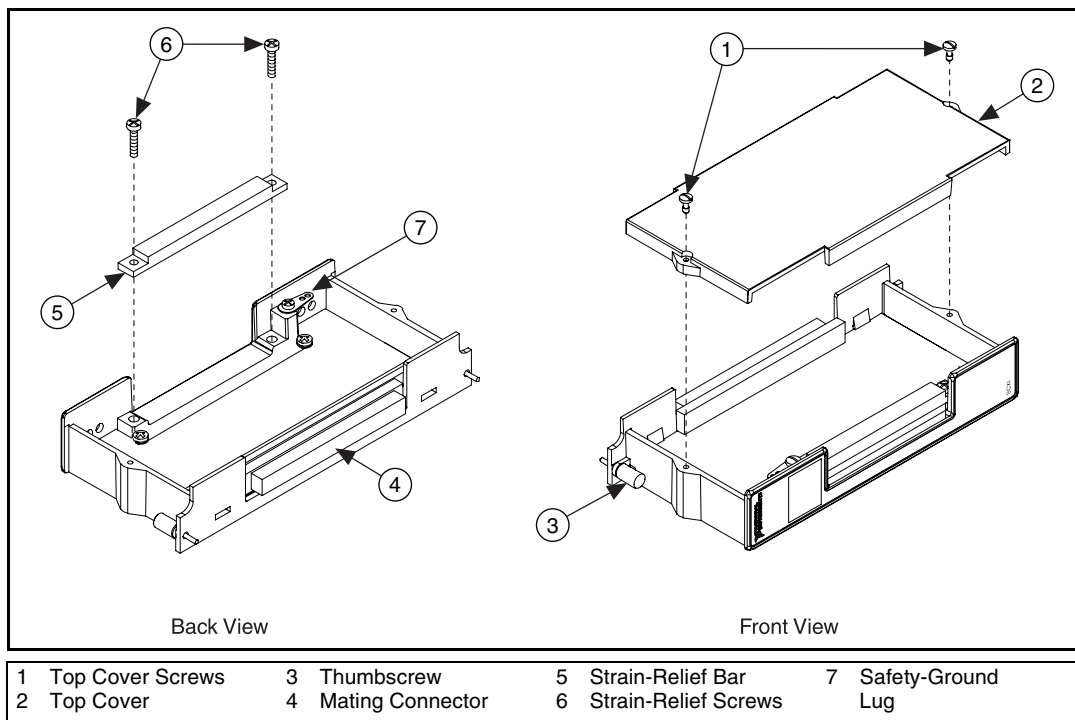

Figure 1. SCXI-1314 Parts Locator Diagram

1. Unscrew the top cover screws and remove the top cover.
2. Loosen the strain-relief screws and remove the strain-relief bar.
3. Run the signal wires through the strain-relief opening. You can add insulation or padding if necessary.
4. Prepare your signal wire by stripping the insulation no more than 7 mm.
5. Connect the signal wires to the screw terminals by inserting the stripped end of the wire fully into the terminal. No bare wire should extend past the screw terminal. Exposed wire increases the risk of a short circuit that can cause circuit failure.

When connecting your signals to the SCXI-1314, follow the labeling on the SCXI-1314, as indicated in Figure 2.

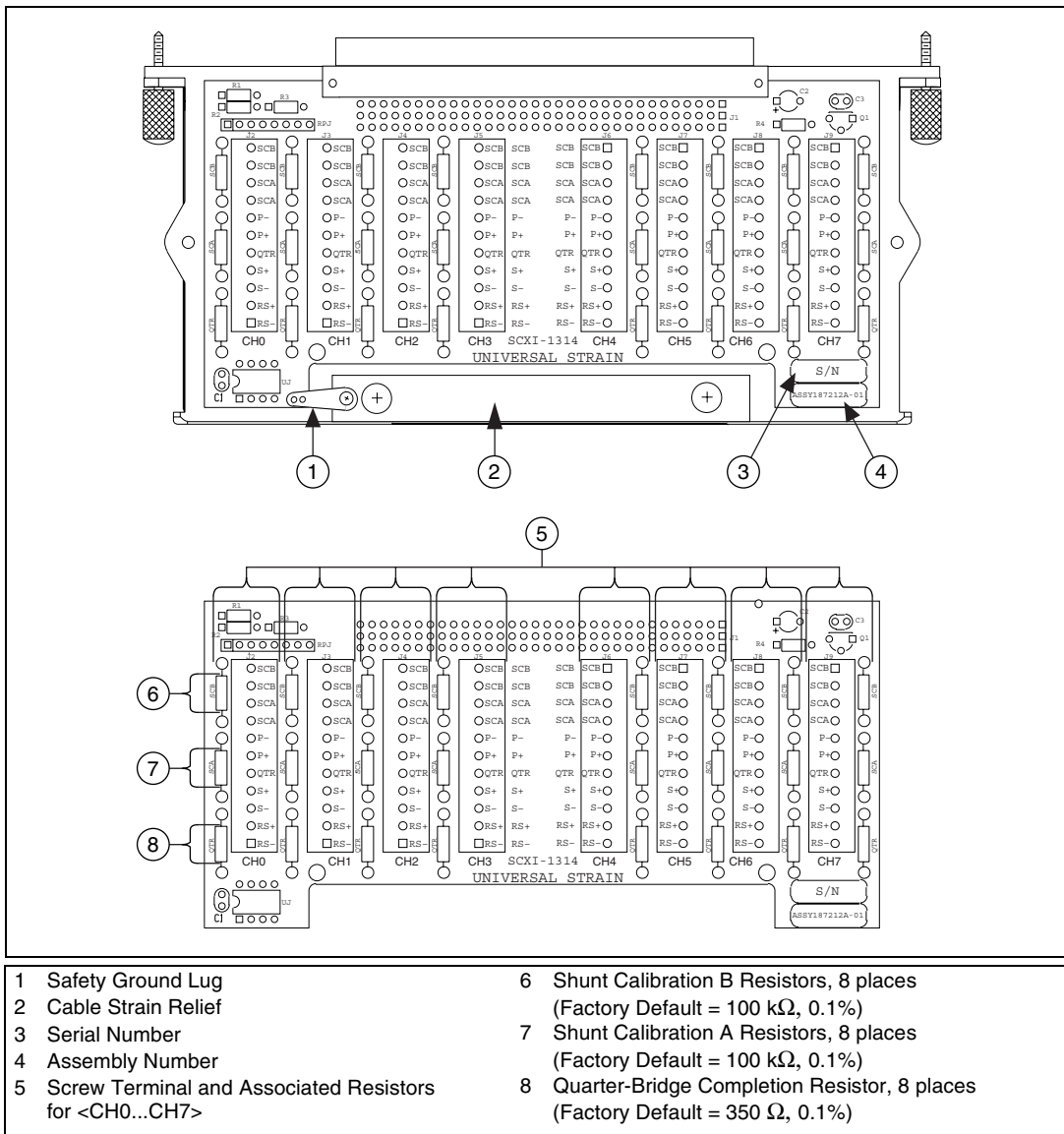

Figure 2. SCXI-1314 Signal Connections

6. Tighten the terminal screws to a torque of 5 to 7 in.-lb.
7. Reinstall the strain-relief bar and tighten the strain-relief screws.
8. Reinstall the top cover and tighten the top cover screws.
9. Connect the terminal block to the module front connector as explained in the *Installing the Terminal Block* section.

Installing the Terminal Block

To connect the terminal block to the SCXI module front connector, perform the following steps:

1. Connect the module front connector to its mating connector on the terminal block.
2. Tighten the top and bottom thumbscrews on the back of the terminal block to hold it securely in place.

Cleaning the Terminal Block

Clean the terminal block by brushing off light dust with a soft, nonmetallic brush. Remove other contaminants with deionized water and a stiff nonmetallic brush. The unit must be completely dry and free from contaminants before returning it to service.

Calibrating the Terminal Block

For information on calibrating the SCXI-1314 see the *SCXI-1314 Universal Strain Terminal Block Calibration Procedure* located online at ni.com/calibration and follow the link for *Manual Calibration Procedures*.

Specifications

All specifications are typical at 25 °C unless otherwise specified.

Electrical

Accuracy of resistors

120 Ω completion resistor..... $\pm 0.1\%$

350 Ω completion resistor..... $\pm 0.1\%$

100 k Ω shunt calibration resistor.... $\pm 0.1\%$

Temperature coefficient of resistors

120 Ω completion resistor..... ± 10 ppm/ $^{\circ}\text{C}$

350 Ω completion resistor..... ± 10 ppm/ $^{\circ}\text{C}$

100 k Ω shunt calibration resistor.... ± 10 ppm/ $^{\circ}\text{C}$

Mechanical

Resistor sockets

Mating lead size.....	0.023 to 0.026 in.
Mating lead length.....	0.110 to 0.175 in.
Lead spacing.....	0.500 in.

Environment

Operating temperature	0 to 50 °C
Storage temperature	-20 to 70 °C
Relative humidity	10 to 90%
Indoor use only	



322859A-01

Aug00