

## COMPREHENSIVE SERVICES

We offer competitive repair and calibration services, as well as easily accessible documentation and free downloadable resources.

## SELL YOUR SURPLUS

We buy new, used, decommissioned, and surplus parts from every NI series. We work out the best solution to suit your individual needs.

 Sell For Cash  Get Credit  Receive a Trade-In Deal

## OBSOLETE NI HARDWARE IN STOCK & READY TO SHIP

We stock **New**, **New Surplus**, **Refurbished**, and **Reconditioned** NI Hardware.



*Bridging the gap between the manufacturer and your legacy test system.*

 1-800-915-6216

 [www.apexwaves.com](http://www.apexwaves.com)

 [sales@apexwaves.com](mailto:sales@apexwaves.com)

*All trademarks, brands, and brand names are the property of their respective owners.*

**Request a Quote**

 **CLICK HERE**

**cRIO-9036**

# NI cRIO-9036

Embedded CompactRIO Controller with Real-Time Processor and Reconfigurable FPGA

This document describes the features of the National Instruments cRIO-9036 and contains information about mounting and operating the device.

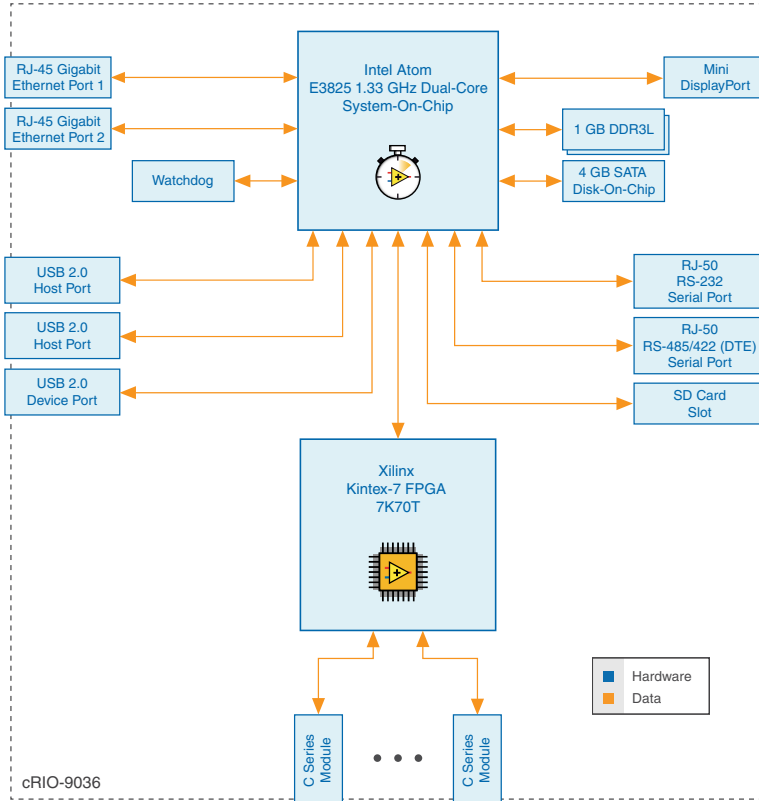

# Contents

---

Configuring the cRIO-9036.....	2
Connecting the cRIO-9036 to the Host Computer or Network Using Ethernet.....	3
Configuring Startup Options.....	4
cRIO-9036 Features.....	6
Ports and Connectors.....	6
Buttons.....	14
LEDs.....	16
Chassis Grounding Screw.....	19
Internal Real-Time Clock.....	20
CMOS Battery.....	20
File System.....	20
Installing the Module Immobilization Accessory.....	21
Module Immobilization Accessory Dimensions.....	22
Mounting the Device.....	23
Dimensions.....	24
Mounting Requirements.....	24
Ambient Temperature.....	25
Mounting the Device Directly on a Flat Surface.....	26
Mounting the cRIO-9036 on a Panel.....	28
Mounting the cRIO-9036 on a DIN Rail.....	29
Mounting the Device on a Rack.....	31
Mounting the Device on a Desktop.....	31
BIOS Configuration.....	32
Resetting the System CMOS and BIOS Settings.....	32
Power-On Self Test Warning Messages.....	33
BIOS Setup Utility.....	33
Main Setup Menu.....	34
Advanced Setup Menu.....	35
Boot Setup Menu.....	36
Save & Exit Menu.....	38
Worldwide Support and Services.....	39

## Configuring the cRIO-9036

---

You can connect the cRIO-9036 to a host computer or network and configure the startup options using the USB device port or the RJ-45 Gigabit Ethernet port 1 or port 2.



**Tip** Refer to the getting started guide on [ni.com/manuals](https://ni.com/manuals) for basic configuration instructions and information about connecting to a host computer using the USB device port. NI recommends using the USB device port for configuration, debug, and maintenance.

# Connecting the cRIO-9036 to the Host Computer or Network Using Ethernet

Complete the following steps to connect the cRIO-9036 to a host computer or Ethernet network using the RJ-45 Gigabit Ethernet port 1. NI recommends using the RJ-45 Gigabit Ethernet port 1 for communication with deployed systems.



**Note** You can configure the RJ-45 Gigabit Ethernet port 2 in Measurement & Automation Explorer (MAX) under the **Network Settings** tab.

1. Power on the host computer or Ethernet hub.
2. Connect the RJ-45 Gigabit Ethernet port 1 on the cRIO-9036 to the host computer or Ethernet hub using a standard Category 5 (CAT-5) or better shielded, twisted-pair Ethernet cable.



**Caution** To prevent data loss and to maintain the integrity of your Ethernet installation, do not use a cable longer than 100 m (328 ft).

The cRIO-9036 attempts to initiate a DHCP network connection the first time you connect using Ethernet. The cRIO-9036 connects to the network with a link-local IP address with the form 169.254.x.x if it is unable to initiate a DHCP connection.

## Finding the cRIO-9036 on the Network (DHCP)

Complete the following steps to find the cRIO-9036 on a network using DHCP.

1. Disable secondary network interfaces on the host computer, such as a wireless access card on a laptop.
2. Ensure that any anti-virus and firewall software running on the host computer allows connections to the host computer.



**Note** MAX uses UDP 44525. Refer to the documentation of your firewall software for information about configuring the firewall to allow communication through the UDP 44525.

3. Launch MAX on the host computer.
4. Expand **Remote Systems** in the configuration tree and locate your system.



**Tip** MAX lists the system under the model number followed by the serial number, such as NI-cRIO-9036-1856AAA.

## Finding the cRIO-9036 on the Network (Static IP)

Complete the following steps to find the cRIO-9036 on the network if the host computer is using a static IP address. The following instructions are for host computers running Windows 7. For more information about performing the network configuration steps in this section, visit [www.microsoft.com](http://www.microsoft.com) and search for `change tcp/ip settings`.

1. Obtain IP settings from the host computer.
  - a) Click **Start>Control Panel>Network and Sharing Center**.
  - b) Select the primary network connection, which may appear as **Local Area Connection** or something similar.

- c) In the dialog box that appears, click **Properties**.
- d) Select **Internet Protocol Version 4 (TCP/IPv4)**.
- e) Click **Properties**.
- f) Record the **IP address**, **Subnet mask**, and **Default gateway** address. You need these settings to configure the network settings of the cRIO-9036 and to restore the network settings of the host computer.



**Tip** You can also access these settings by opening the Start menu, entering `cmd.exe`, and entering `ipconfig` in the command window that launches.

- g) Wait at least one minute.
2. Configure IP Settings on the controller in MAX.
  - a) Launch MAX on the host computer.
  - b) Expand **Remote Systems** in the configuration tree and locate your system.



**Tip** MAX lists the system under the model number followed by the serial number, such as NI-cRIO-9036-1856AAA.

- c) Select the **Network Settings** tab near the bottom of the window.
- d) Select **Static** on the **Configure IPv4 Address** control.
- e) Enter values for **IPv4 Address**, **Subnet Mask**, **Gateway**, and **DNS Server** based on the information you recorded. Be sure to enter a value for **IPv4 Address** that is not used by another device on the network. For example, do not use the IP address usually assigned to the host computer.
- f) Click **Save** and let MAX restart the cRIO-9036. The cRIO-9036 disappears from under **Remote Systems** and does not reappear until you restore the original network settings to the host computer.
- g) Restore the original network settings to the host computer.
- h) Return to MAX and refresh **Remote Systems**.

## Configuring Startup Options

Complete the following steps to configure the cRIO-9036 startup options in MAX.

1. In MAX, expand your system under Remote Systems.
2. Select the **Startup Settings** tab to configure the startup settings.

### cRIO-9036 Startup Options

You can configure the following cRIO-9036 startup options.

**Table 1. cRIO-9036 Startup Options**

<b>Startup Option</b>	<b>Description</b>
Force Safe Mode	Rebooting the cRIO-9036 with this setting on starts the cRIO-9036 without launching LabVIEW Real-Time or any startup applications. In safe mode, the cRIO-9036 launches only the services necessary for updating configuration and installing software.
Enable Console Out	<p>Rebooting the cRIO-9036 with this setting on redirects the console output to the RS-232 serial port. You can use a serial-port terminal program to read the IP address and firmware version of the cRIO-9036. Use a null-modem cable to connect the RS-232 serial port to a computer. Make sure that the serial-port terminal program is configured to the following settings:</p> <ul style="list-style-type: none"> <li>• 115,200 bits per second</li> <li>• Eight data bits</li> <li>• No parity</li> <li>• One stop bit</li> <li>• No flow control</li> </ul>
Disable RT Startup App	Rebooting the cRIO-9036 with this setting on prevents any LabVIEW startup applications from running.
Disable FPGA Startup App	Rebooting the cRIO-9036 with this setting on prevents autoloading of any FPGA application.
Enable Secure Shell (SSH) Logins	<p>Rebooting the cRIO-9036 with this setting on starts sshd on the cRIO-9036. Starting sshd enables logins over SSH, an encrypted communication protocol.</p> <p> <b>Note</b> Visit <a href="http://ni.com/info">ni.com/info</a> and enter the Info Code <code>openssh</code> for more information about SSH.</p>
LabVIEW Project Access	Rebooting the cRIO-9036 with this setting on enables you to add the target to a LabVIEW project.
Enable Embedded UI	Rebooting the cRIO-9036 with this setting on enables the embedded UI, which allows you to interact with the front panels of VIs running on the cRIO-9036 using input and display devices connected directly to the cRIO-9036. You can also browse and edit files on the cRIO-9036 within a graphical working environment. For more information, refer to the <i>Using the Embedded UI to Access RT Target VIs</i> topic in the <i>LabVIEW Help</i> .

# cRIO-9036 Features

The cRIO-9036 provides the following features.

## Ports and Connectors

The cRIO-9036 provides the following ports and connectors.

**Figure 1. cRIO-9036 Ports and Connectors**

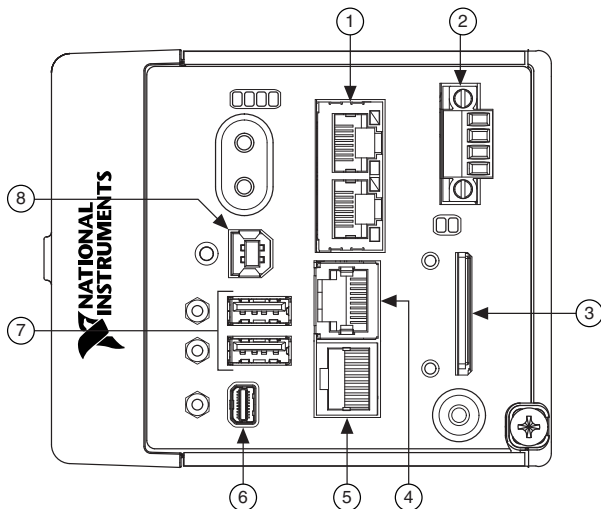

- |                                 |                                 |
|---------------------------------|---------------------------------|
| 1. RJ-45 Gigabit Ethernet Ports | 5. RS-485/422 (DTE) Serial Port |
| 2. Power Connector              | 6. Mini DisplayPort             |
| 3. SD Card Removable Storage    | 7. USB Host Ports               |
| 4. RS-232 Serial Port           | 8. USB Device Port              |

## RJ-45 Gigabit Ethernet Ports

The cRIO-9036 has two tri-speed RJ-45 Gigabit Ethernet ports. By default, both Ethernet ports are enabled and configured to obtain an IP address automatically. The Ethernet ports can be configured in MAX.

The following table shows the pinout for the RJ-45 Gigabit Ethernet ports.

**Table 2.** RJ-45 Gigabit Ethernet Port Pinout

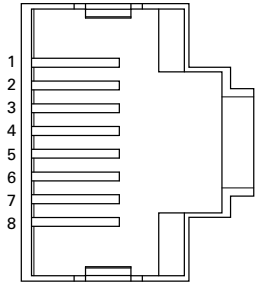
Fast Ethernet Signal	Gigabit Ethernet Signal	Pin	Pinout
TX+	TX_A+	1	
TX-	TX_A-	2	
RX+	RX_B+	3	
No Connect	TX_C+	4	
No Connect	TX_C-	5	
RX-	RX_B-	6	
No Connect	RX_D+	7	
No Connect	RX_D-	8	



**Note** Both Ethernet ports perform automatic crossover configuration so you do not need to use a crossover cable to connect to a host computer.

The following NI Ethernet cables are available for the cRIO-9036.

**Table 3.** RJ-45 Gigabit Ethernet Cables

Cables	Length	Part Number
CAT-5E Ethernet Cable, shielded	2 m	151733-02
	5 m	151733-05
	10 m	151733-10

## Related Information

[Ethernet LED Indicators](#) on page 18

## Power Connector

The cRIO-9036 has a power connector to which you can connect a primary and secondary power supply. The following table shows the pinout for the power connector.

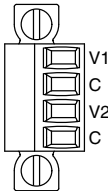

**Table 4. Power Connector Pinout**

Pinout	Pin	Description
	V1	Primary power input
	C	Common
	V2	Secondary power input
	C	Common



**Caution** The C terminals are internally connected to each other, but are not connected to chassis ground. This isolation is intended to prevent ground loops and does not meet UL ratings for safety isolation. You can connect the C terminals to chassis ground externally. Refer to the specifications on [ni.com/manuals](http://ni.com/manuals) for information about the power supply input range and maximum voltage from terminal to chassis ground.

If you apply power to both the V1 and V2 inputs, the cRIO-9036 operates from the V1 input. If the input voltage to V1 is insufficient, the cRIO-9036 operates from the V2 input.

The cRIO-9036 has reverse-voltage protection.

The following NI power supplies and accessories are available for the cRIO-9036.

**Table 5. Power Accessories**

Accessory	Part Number
NI PS-15 Power Supply, 24 VDC, 5 A, 100-120/200-240 VAC Input	781093-01
NI PS-10 Desktop Power Supply, 24 VDC, 5 A, 100-120/200-240 VAC Input	782698-01
4-Position Gold Power Supply Plugs (Quantity 5)	783529-01
NI 9979 Strain Relief for 4-Position Power Connector	196939-01

### Related Information

[POWER LED Indicators](#) on page 16

## SD Card Removable Storage

The cRIO-9036 provides an SD card slot that can read from and write to NI-approved SD cards.



**Caution** You must use the SD card slot cover to protect the SD card in hazardous locations.



**Caution** Do not insert or remove SD cards unless power has been switched off or the area is known to be nonhazardous.



**Note** Using SD cards that are not approved by NI might invalidate specifications and result in unreliable performance.

The following accessories are available for the SD card slot.

**Table 6.** cRIO-9036 SD Storage Accessories

SD Card	Capacity	Part Number
SD Industrial Storage Card	16 GB	786362-01
	32 GB	786363-01
SD Door (x3)	—	783660-01

### Related Information

[File System](#) on page 20

### SD Card Slot Cover

You must use the SD card slot cover to protect the SD card in hazardous locations. Do not remove an SD card while either LED is flashing or lit because file corruption may result.



**Note** Screw the slot cover closed completely. Tighten the captive screws to a maximum torque of 0.75 N · m (6.7 lb · in.) using a #1 Phillips screwdriver. Do not overtighten.

### RS-232 Serial Port

The cRIO-9036 has an RS-232 serial port that is implemented with an RJ-50, 10-position modular jack to which you can connect devices such as displays or input devices. Use the Serial VIs to read from and write to the serial port. Refer to the *LabVIEW Help* for information about the Serial VIs.

Find examples on how to use NI-Serial or NI-VISA to perform serial communication in the NI Example Finder. The NI Example Finder is located on the Help menu in the *LabVIEW Help*.



**Note** The RS-232 serial port cannot be accessed by the user application when the Console Out startup option is enabled.

The following table shows the pinout for the RS-232 serial port.

**Table 7. RS-232 Serial Port Pinout**

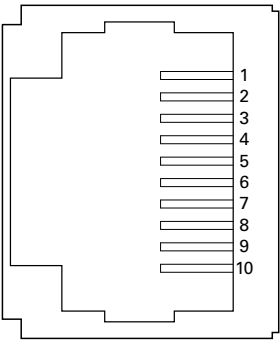
Pinout	Pin	Signal
	1	No Connect
	2	RI
	3	CTS
	4	RTS
	5	DSR
	6	GND
	7	DTR
	8	TXD
	9	RXD
	10	DCD

You can use the Ring Indicator (RI) on pin 2 to wake the controller from a low-power state. You can drive RI with a logic level high to wake the cRIO-9036. Refer to the specifications on [ni.com/manuals](http://ni.com/manuals) for the RI wake voltage.

The following accessories are available to connect the RS-232 serial port to a 9-pin DSUB plug.

**Table 8. RS-232 Serial Port Accessories**

Accessory	Length	Part Number
RS-232, S8 Serial Cable, 10-Position Modular Plug to 9-Pin DSUB	1 m	182845-01
	2 m	182845-02
	3 m	182845-03

## RS-485/422 (DTE) Serial Port

The cRIO-9036 has an RS-485/422 (DTE) serial port that is implemented with an RJ-50, 10-position modular jack. The RJ-50 connector is isolated from the cRIO-9036. For more information about the electrical isolation of the RS-485/422 (DTE) port, refer to the specifications on [ni.com/manuals](http://ni.com/manuals).

Find examples on how to use NI-Serial or NI-VISA to perform serial communication in the NI Example Finder. The NI Example Finder is located on the Help menu in the *LabVIEW Help*.

The following table shows the pinout for the RS-485/422 (DTE) serial port.

**Table 9.** RS-485/422 (DTE) Serial Port Pinout

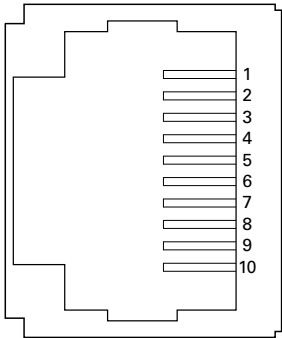
Pinout	Pin	Signal
	1	No Connect
	2	TXD-
	3	TXD+
	4	No Connect
	5	No Connect
	6	RXD-
	7	RXD+
	8	No Connect
	9	No Connect
	10	Isolated GND

The following accessory is available to connect the RS-485/422 (DTE) serial port to a 9-pin DSUB plug.



**Caution** To ensure the specified EMC performance, you must use an isolated cable with the RS-485/422 (DTE) serial port. The following accessory meets this requirement.

**Table 10.** RS-485/422 (DTE) Serial Port Accessory

Accessory	Length	Part Number
RS-485, S8 Serial Cable, 10-Position Modular Plug to 9-Pin DSUB (Isolated)	1 m	184428-01

## Mini DisplayPort

Use the Mini DisplayPort to connect a monitor and implement a local HMI. You can use a single real-time VI to interactively develop both your user interface and system logic. For more information, refer to the *Using the Embedded UI to Access RT Target VIs* topic in the *LabVIEW Help*.



**Caution** Do not hot-swap Mini DisplayPort devices while the cRIO-9036 is in a hazardous location or connected to high voltages.

The following table shows the pinout for the Mini DisplayPort.

**Table 11. Mini DisplayPort Pinout**

Signal	Pin	Pinout	Pin	Signal
DP_PWR	20		19	GND
AUX_CH(n)	18		17	ML_Lane2(n)
AUX_CH(p)	16		15	ML_Lane2(p)
GND	14		13	GND
ML_Lane3(n)	12		11	ML_Lane1(n)
ML_Lane3(p)	10		9	ML_Lane1(p)
GND	8		7	GND
CONFIG2	6		5	ML_Lane0(n)
CONFIG1	4		3	ML_Lane0(p)
Hot Plug	2		1	GND

The following adapters are available to connect the Mini DisplayPort to full-size DisplayPort, VGA, or DVI. The cRIO-9036 only supports DVI single link. Refer to the cRIO-9036 pricing page on [ni.com](http://ni.com) for a complete list of cables and accessories.

**Table 12. Mini DisplayPort Accessories**

Accessory	Length	Part Number
Mini DisplayPort to Full DisplayPort Native Cable	0.5 m	157232-0R5
	1 m	157232-01
	2 m	157232-02
Mini DisplayPort to VGA Adapter Cable	0.5 m	157230-0R5
Mini DisplayPort to DVI Adapter Cable	0.5 m	157231-0R5
Mini DisplayPort Retention Accessory	—	156866-01

## USB Host Ports

The USB host ports on the cRIO-9036 support common USB mass-storage devices such as USB Flash drives, USB-to-IDE adapters, keyboards, mice, and USB cameras.



**Caution** Do not hot-swap USB devices while the cRIO-9036 is in a hazardous location or connected to high voltages. If the cRIO-9036 is not in a hazardous location, you can connect and disconnect USB devices without affecting operation.

The following table shows the pinout for the USB host ports.

**Table 13. USB Host Port Pinout**

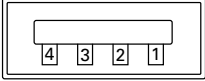
Pinout	Pin	Signal	Description
	1	VCC	Cable power (5 V)
	2	D-	USB data-
	3	D+	USB data+
	4	GND	Ground

The following NI cable is available for the cRIO-9036.

**Table 14. USB Host Port Cable**

Cable	Length	Part Number
USB Extension with Retention, Type A Connectors	0.5 m	152166-0R5
	2 m	152166-02

## Related Information

[File System](#) on page 20

## Installing a Ferrite on the USB Cables

You must install a ferrite around all USB cables connected to the USB host ports to ensure that the cRIO-9036 meets all EMC standards applicable to your country.

### What to Use

- Ferrite (711849-01), included with the cRIO-9036
- USB cables

### What to Do

Install the ferrite on the USB cables, as shown in the following figure.

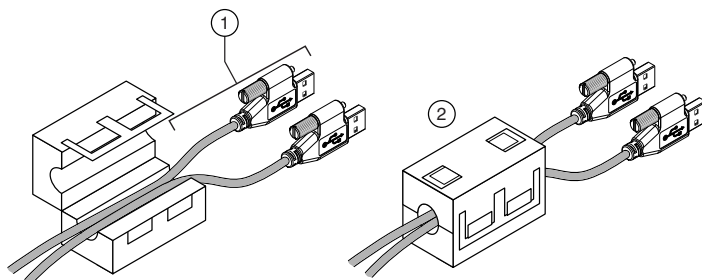
**Figure 2. Installing a Ferrite on the USB Cables**

1. Pass the cables through the ferrite, leaving 50 mm to 75 mm (2 in. to 3 in.) between the ferrite and the end of the cables. The ferrite can accommodate up to two USB cables depending on the diameter of each cable.
2. Close the ferrite around the cables.

## USB Device Port

The cRIO-9036 USB device port is intended for device configuration, application deployment, debugging, and maintenance. For example, you can use the USB device port to install software or driver updates during field maintenance instead of interrupting communication on the RJ-45 Ethernet ports.



**Caution** Do not hot-swap USB devices while the cRIO-9036 is in a hazardous location or connected to high voltages. If the cRIO-9036 is not in a hazardous location, you can connect and disconnect USB devices without affecting operation.

The following table shows the pinout for the USB device port.

Description	Signal	Pin	Pinout	Pin	Signal	Description
USB data+	D+	3		2	D-	USB data-
Ground	GND	4		1	VCC	Cable power (5 V)

The following NI cable is available for the cRIO-9036.

**Table 15. USB Device Port Cable**

Cable	Length	Part Number
NI Locking USB Cable	1 m	157788-01

## Buttons

The cRIO-9036 provides the following buttons.

**Figure 3. cRIO-9036 Buttons**

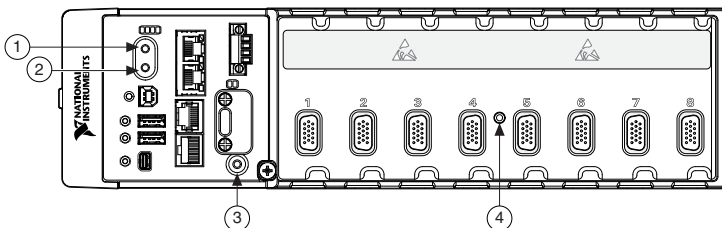

- |                 |                      |
|-----------------|----------------------|
| 1. Power Button | 3. USER1 Button      |
| 2. RESET Button | 4. CMOS Reset Button |

## Power Button

The default behavior for the cRIO-9036 is to power on when you apply power to the controller and power off when you press and release the power button. The behavior of the power button can be configured in the BIOS.

If the cRIO-9036 becomes unresponsive, you can power it off by holding the power button for 4 seconds.

### Related Information

[Power/Wake Configuration Submenu](#) on page 35

## RESET Button

Press the RESET button to reset the processor in the same manner as cycling power.

### Troubleshooting Network Connectivity

You can use the RESET button to troubleshoot network connectivity.

Complete the following steps to reset the network adapters to default settings.

1. Hold the RESET button for 5 seconds, and then release it to boot the controller in safe mode and enable Console Out.
2. Hold the RESET button again for 5 seconds to boot the controller into safe mode, enable Console Out, and reset network adapters to default settings.

### System Reset

The following figure shows the reset behavior of the cRIO-9036.

**Figure 4. Reset Button Behavior**

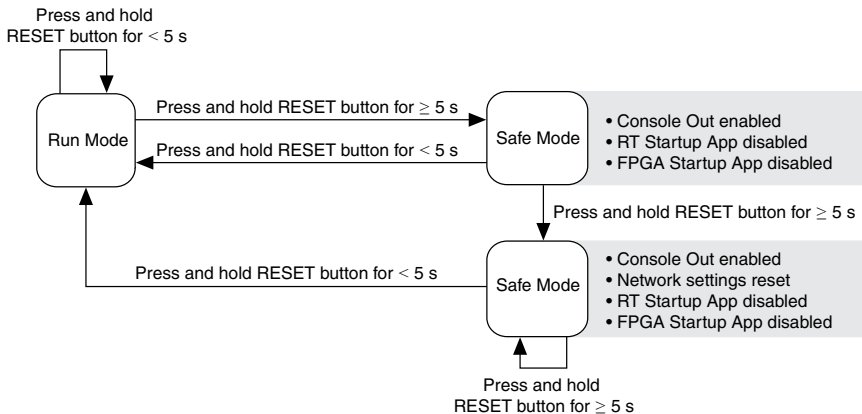



## USER1 Button

The cRIO-9036 has a general-purpose USER1 button that is user-defined. You can read the state of the USER1 button from your LabVIEW FPGA application.

## CMOS Reset Button

The cRIO-9036 has a CMOS reset button that you can use to reset the CMOS and the BIOS.

## LEDs

The cRIO-9036 provides the following LEDs.

**Figure 5. cRIO-9036 LEDs**

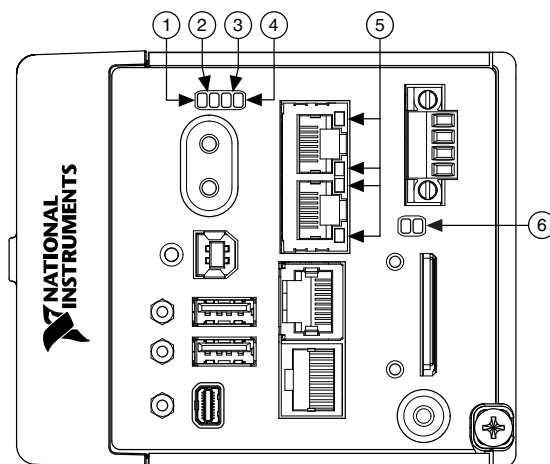

1. POWER LED
2. STATUS LED
3. USER1 LED

4. USER FPGA1 LED
5. Gigabit Ethernet LEDs
6. SD LEDs

## POWER LED Indicators

The following table lists the POWER LED indicators.

**Table 16. POWER LED Indicators**

LED Color	LED Pattern	Indication
Green	Solid	The cRIO-9036 is powered from the V1 input.
Yellow	Solid	The cRIO-9036 is powered from the V2 input.
—	Off	The cRIO-9036 is powered off.

## STATUS LED Indicators

The following table describes the STATUS LED indicators.

**Table 17. STATUS LED Indicators**

LED Color	LED Pattern	Indication
Yellow	Blinks twice and pauses	The cRIO-9036 is in safe mode. Software is not installed, which is the factory default state, or software has been improperly installed on the cRIO-9036.  An error can occur when an attempt to upgrade the software is interrupted. Reinstall software on the cRIO-9036. Refer to the <i>Measurement &amp; Automation Explorer (MAX) Help</i> for information about installing software on the cRIO-9036.
	Blinks three times and pauses	The cRIO-9036 is in user-directed safe mode, or the cRIO-9036 is in install mode to indicate that software is currently being installed.  This pattern may also indicate that the user has forced the cRIO-9036 to boot into safe mode by pressing the reset button for longer than five seconds or by enabling safe mode in MAX. Refer to the <i>Measurement &amp; Automation Explorer (MAX) Help</i> for information about safe mode.
	Blinks four times and pauses	The cRIO-9036 is in safe mode. The software has crashed twice without rebooting or cycling power between crashes.
	Continuously blinks	The cRIO-9036 has not booted into NI Linux Real-Time. The cRIO-9036 either booted into an unsupported operating system, was interrupted during the boot process, or detected an unrecoverable software error.
	On momentarily	The cRIO-9036 is booting. No action required.
Red	Continuously blinks	This indicates a hardware error. An internal power supply has failed. Check front-panel I/O and C Series module connections for shorts. Remove any shorts and cycle power the cRIO-9036. If the problem persists, contact NI.
—	Off	The cRIO-9036 is in run mode. Software is installed and the operating system is running.

## User LEDs

You can define the USER1 and USER FPGA1 LEDs to meet the needs of your application. The following table lists the USER1 and USER FPGA1 LED indicators.

**Table 18.** User LEDs

LED	LED Color	Description
USER1	Green/Yellow	Use LabVIEW Real-Time to define the USER1 LED with the RT LEDs VI. For more information about the RT LEDs VI, refer to the <i>LabVIEW Help</i> .
USER FPGA1	Green/Yellow	Use the LabVIEW FPGA Module and NI-RIO Device Drivers software to define the USER FPGA1 LED. Use the USER FPGA1 LED to help debug your application or retrieve application status. Refer to the <i>LabVIEW Help</i> for information about programming this LED.

## Ethernet LED Indicators

The following table lists the Ethernet LED indicators.

**Table 19.** Ethernet LED Indicators

LED	LED Color	LED Pattern	Indication
ACT/LINK	—	Off	LAN link not established
	Green	Solid	LAN link established
		Flashing	Activity on LAN
10/100/1000	Yellow	Solid	1,000 Mbit/s data rate selected
	Green	Solid	100 Mbit/s data rate selected
	—	Off	10 Mbit/s data rate selected

## SD LED Indicators

The cRIO-9036 has two LEDs that indicate the SD card drive mount status and activity. The following table lists SD LED indicators.

**Table 20. SD LED Indicators**

LED	LED Color	LED Pattern	Indication
SD ACT	Yellow	Off	There is no I/O activity on the SD card in the slot.
		Flashing	The cRIO-9036 is performing I/O on the SD card in the slot. Do not remove the SD card while this LED is flashing.
SD IN USE	Green	Off	There is no SD card present in the slot or the cRIO-9036 has unmounted the SD card from the operating system. It is safe to remove the SD card from the slot.
		Solid	The SD card in the slot is mounted in the operating system. Do not remove the SD card while this LED is lit.

## Chassis Grounding Screw

The cRIO-9036 provides a chassis grounding screw.

**Figure 6. cRIO-9036 Chassis Grounding Screw**

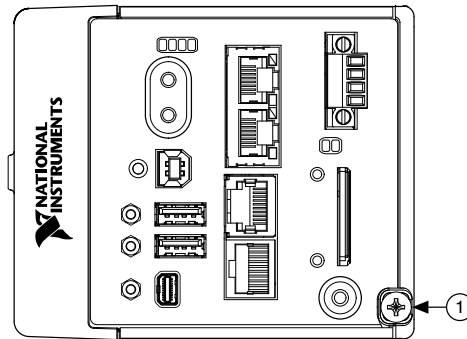

1. Chassis Grounding Screw

For EMC compliance, you must connect the cRIO-9036 to earth ground through the chassis ground screw. Use wire that is 1.31 mm<sup>2</sup> (16 AWG) solid copper wire with a maximum length of 1.5 m (5 ft). Attach the wire to the earth ground of the electrode system of the facility.



**Caution** If you use shielded cabling to connect to a C Series module with a plastic connector, you must attach the cable shield to the chassis grounding terminal using 1.31 mm<sup>2</sup> (16 AWG) or larger wire. Attach a ring lug to the wire and attach the wire

to the chassis grounding terminal. Solder the other end of the wire to the cable shield. Use shorter wire for better EMC performance.

For more information about ground connections, visit [ni.com/info](http://ni.com/info) and enter the Info Code `emcground`.

## Internal Real-Time Clock

The cRIO-9036 contains an internal real-time clock that maintains system time when the cRIO-9036 is powered off. The system clock of the cRIO-9036 is synchronized with the internal real-time clock at startup. You can set the real-time clock using the BIOS setup utility or MAX, or you can set the clock programmatically using LabVIEW.

Refer to the specifications on [ni.com/manuals](http://ni.com/manuals) for the real-time clock accuracy specifications.

## CMOS Battery

The cRIO-9036 contains a CMOS battery. The CMOS battery is a lithium cell battery that stores the system clock information when the cRIO-9036 is powered off. There is only a slight drain on the CMOS battery when power is applied to the cRIO-9036 power connector. The rate at which the CMOS battery drains when power is disconnected depends on the ambient storage temperature. For longer battery life, store the cRIO-9036 at a cooler temperature and apply power to the power connector. Refer to the specifications on [ni.com/manuals](http://ni.com/manuals) for the expected battery lifetime.

The `CMOS BATTERY IS DEAD` warning appears onscreen during the power-on self test if the battery is dead. The cRIO-9036 still starts, but the system clock is reset to the date and time of the BIOS release. The battery is not user-replaceable. If you need to replace the CMOS battery, contact NI. Refer to the specifications on [ni.com/manuals](http://ni.com/manuals) for information about battery disposal.

## File System

LabVIEW mounts USB devices and SD cards to the `media/sdx1` directory and creates symbolic links `/u`, `/v`, `/w`, or `/x` to the media mount point, starting with `/u` if it is available. To prevent any file corruption to external storage devices, verify that any file IO operations with the specific drive finish before removing the device. Refer to the *LabVIEW Help* for more information.

The file system of the cRIO-9036 follows conventions established for UNIX-style operating systems. Other LabVIEW Real-Time targets follow Microsoft Windows-style conventions. In order to facilitate the porting of applications from those targets, this target supports the Windows-style `/C` home directory. This path is bound to the UNIX-style directory `/home/lvuser`.

Various LabVIEW Real-Time system files which would be accessible from `C:` (or `/C`) on other LabVIEW Real-Time targets are found in different locations on this target.

UNIX-style file systems support the concept of a symbolic link, which allows access to a file using an alternative file path. For example, it is possible to link `/C/ni-rt/system`, where dynamic libraries are deployed on other LabVIEW Real-Time targets, to `/usr/local/lib`, where they are stored on the cRIO-9036, if the application requires this.

## Installing the Module Immobilization Accessory

---

The Module Immobilization accessory, part number 158533-01, ensures that the C Series module latches cannot be retracted and modules cannot be removed from a system. The Module Immobilization accessory provides extra system assurance and security when shipping and installing systems, and prevents accidental removal from a system during operation.

When using the Module Immobilization accessory, NI recommends installing the accessory prior to mounting the system in any enclosure because the accessory requires tool access to the top, right, and bottom of the cRIO-9036.

### What to Use

- cRIO-9036
- C Series modules
- Module Immobilization accessory kit, 158533-01
  - Module immobilization bracket
  - Installation screws<sup>1</sup>
    - M4 x 0.7 button-head screw, 8 mm
    - M3 x 0.5 flat-head screws (x2), 10 mm
- Torx T10/T10H driver
- Torx T20/T20H driver

### What to Do

Complete the following steps to install the Module Immobilization accessory.

---

<sup>1</sup> The Module Immobilization accessory kit includes two sets of screws. One set is a standard set of screws that require a standard driver type, Torx T10 and T20. The other set is a tamper-resistant set of screws that require a security driver type, Torx T10H and T20H. Use the tamper-resistant set to help prevent unintended modification of the system.

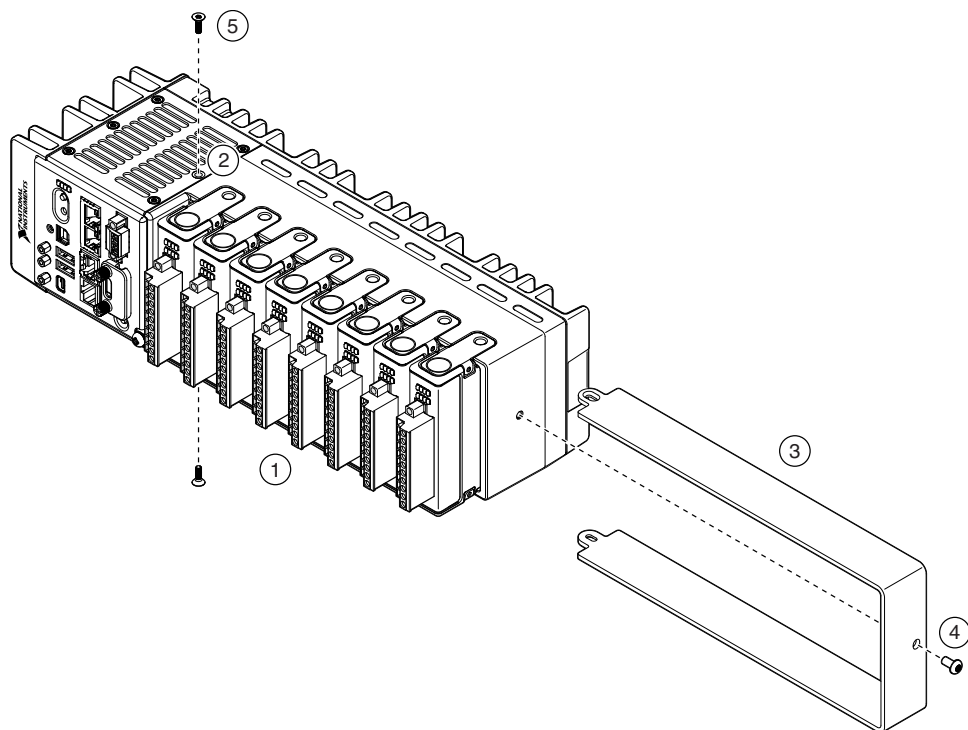

1. Ensure that all the C Series modules are installed in the cRIO-9036 and the latches are locked in place.
2. Remove the center right panel screw from the top and bottom of the cRIO-9036 using the Torx T10 driver.
3. Slide the bracket into place, aligning the three clearance screw holes.
4. Install the M4 x 0.7 button-head screw in the right end of the cRIO-9036 using the appropriate Torx T20 driver. Tighten the screw to a maximum torque of 1.3 N · m (11.5 lb · in.).
5. Install the two M3 x 0.5 flat-head screws from the accessory kit in the top and bottom of the cRIO-9036 using the appropriate Torx T10 driver. Tighten the screws to a maximum torque of 1.3 N · m (11.5 lb · in.).



**Tip** NI recommends using a liquid thread locker for all fasteners if the system is expected to experience vibration for an extended amount of time.

## Module Immobilization Accessory Dimensions

The following figure shows the Module Immobilization accessory dimensions for the cRIO-9036.

**Figure 7. cRIO-9036 Module Immobilization Accessory Dimensions**

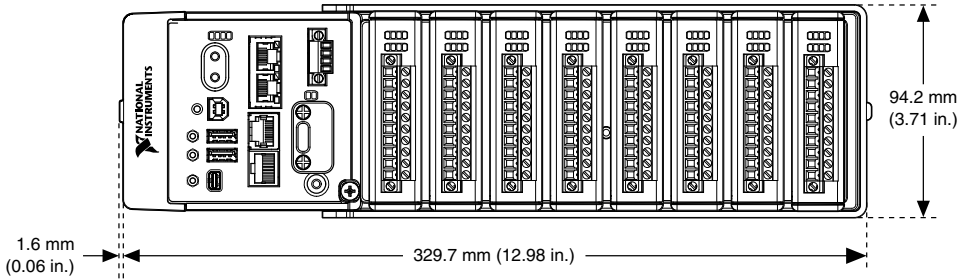

## Mounting the Device

To obtain the maximum allowable ambient temperature of 70 °C, you must mount the cRIO-9036 horizontally on a flat, metallic, vertical surface such as a panel or wall. You can mount the cRIO-9036 directly to the surface or use the NI Panel Mounting Kit. The following figure shows the cRIO-9036 mounted horizontally.

**Figure 8. cRIO-9036 Horizontal Mounting**

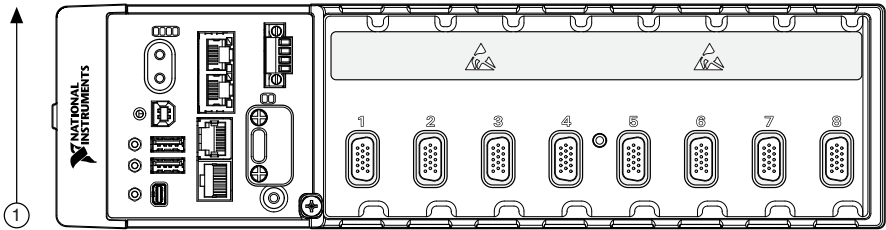

1. Up

You can also mount the cRIO-9036 in other orientations, on a nonmetallic surface, on a 35-mm DIN rail, on a desktop, or in a rack. Mounting the cRIO-9036 in these or other configurations can reduce the maximum allowable ambient temperature and can affect the typical accuracy of modules in the cRIO-9036. For more information about typical accuracy specifications for C Series modules and temperature deratings caused by different mounting configurations, visit [ni.com/info](http://ni.com/info) and enter the Info Code `criotypical`.



**Caution** Make sure that no C Series modules are in the cRIO-9036 before mounting it.



**Tip** Before using any of these mounting methods, record the serial number from the back of the cRIO-9036 so that you can identify the cRIO-9036 in MAX. You will be unable to read the serial number after you mount the cRIO-9036.



# Dimensions

The following figures show the front and side dimensions of the cRIO-9036. For detailed dimensional drawings and 3D models, visit [ni.com/dimensions](http://ni.com/dimensions) and search for the module number.

**Figure 9. cRIO-9036 Front Dimensions**

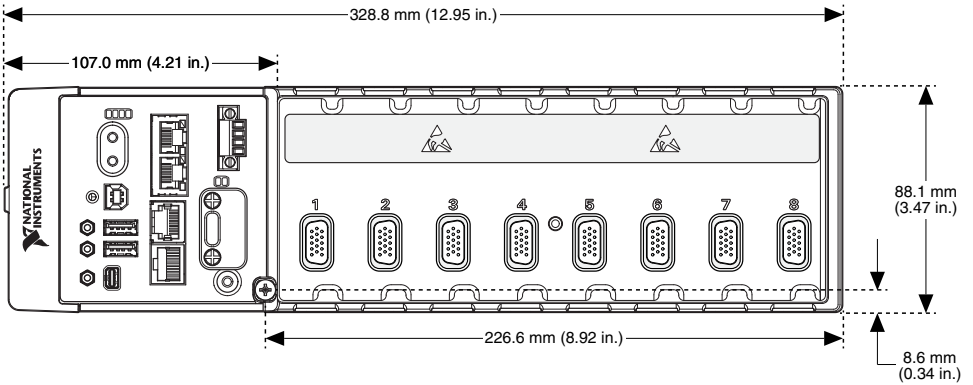

**Figure 10. cRIO-9036 Side Dimensions**

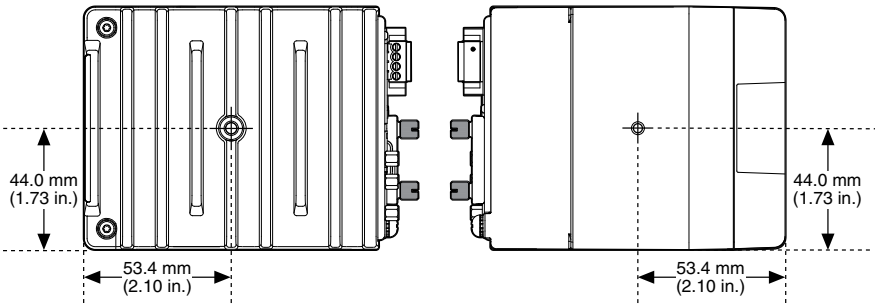

# Mounting Requirements

Your installation must meet the following requirements for cooling and cabling clearance.

Allow 25.4 mm (1.00 in.) on the top and the bottom of the cRIO-9036 for air circulation, as shown in the following figure.

**Figure 11. cRIO-9036 Cooling Dimensions**

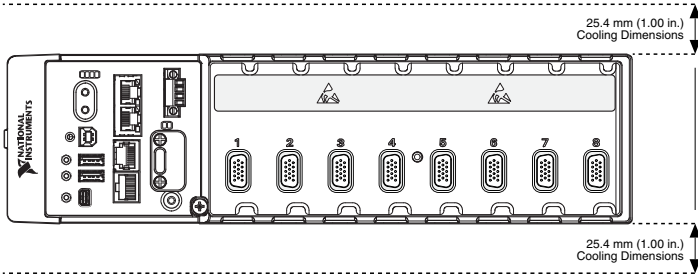

Allow the appropriate space in front of C Series modules for cabling clearance, as shown in the following figure. The different connector types on C Series modules require different cabling clearances. For a complete list of cabling clearances for C Series modules, visit [ni.com/info](http://ni.com/info) and enter the Info Code `crioconn`.

**Figure 12. cRIO-9036 Cabling Clearance**

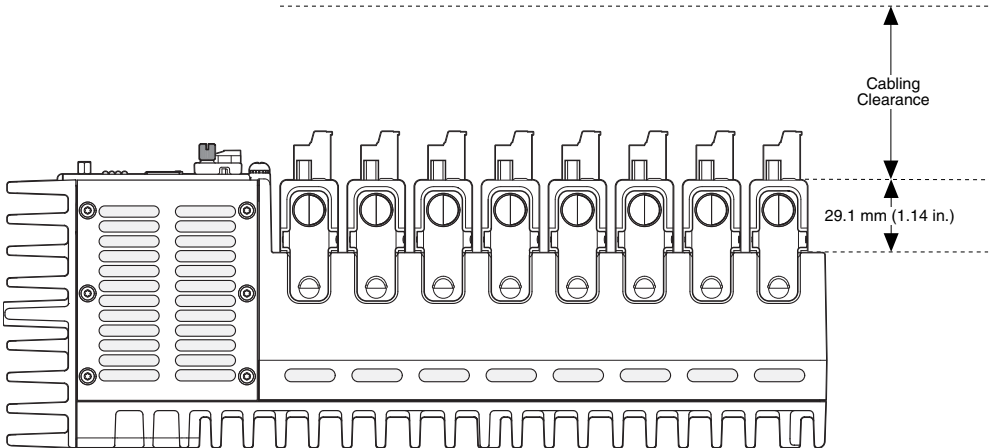

## Ambient Temperature

Measure the ambient temperature at each side of the cRIO-9036, 63.5 mm (2.50 in.) from the side and 38.1 mm (1.50 in.) forward from the rear of the cRIO-9036, as shown in the following figure.

**Figure 13. cRIO-9036 Ambient Temperature Location**

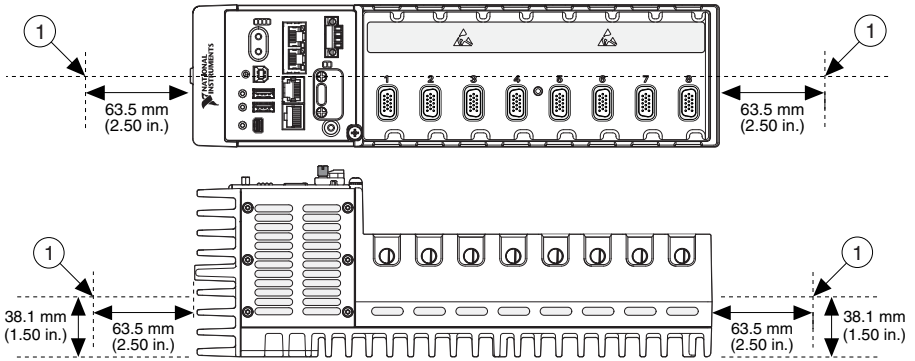

1. Location for measuring the ambient temperature

## Mounting the Device Directly on a Flat Surface

For environments with high shock and vibration, NI recommends mounting the cRIO-9036 directly on a flat, rigid surface using the mounting holes in the cRIO-9036.

### What to Use

- cRIO-9036
- M4 screw (x6), user provided, which must not exceed 8 mm of insertion into the cRIO-9036

### What to Do

Complete the following steps to mount the cRIO-9036 directly on a flat surface.

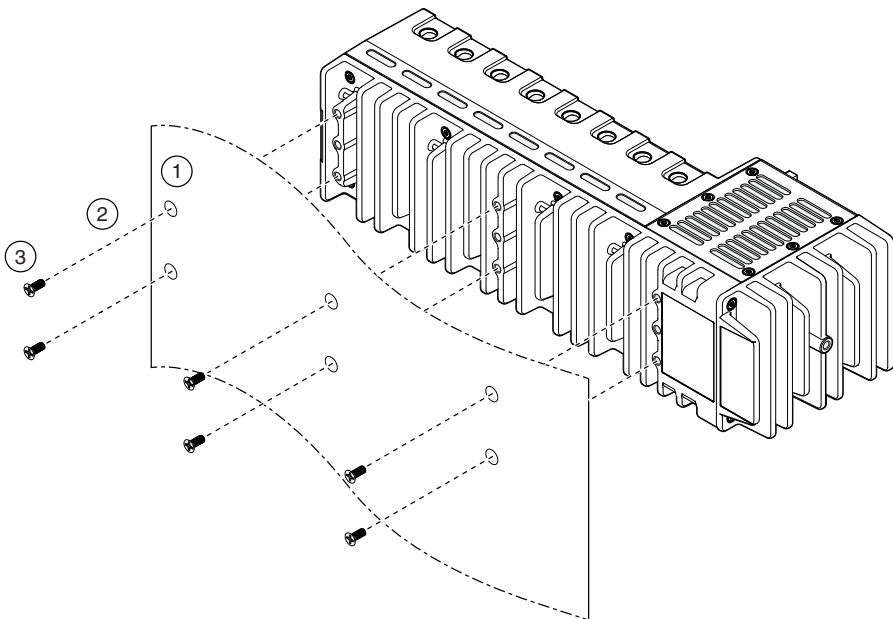

1. Prepare the surface for mounting the cRIO-9036 using the [Surface Mounting Dimensions](#).
2. Align the cRIO-9036 on the surface.
3. Fasten the cRIO-9036 to the surface using the M4 screws appropriate for the surface. Screws must not exceed 8 mm of insertion into the cRIO-9036. Tighten the screws to a maximum torque of 1.3 N · m (11.5 lb · in.).

## Surface Mounting Dimensions

The following figure shows the surface mounting dimensions for the cRIO-9036.

**Figure 14. cRIO-9036 Surface Mounting Dimensions**

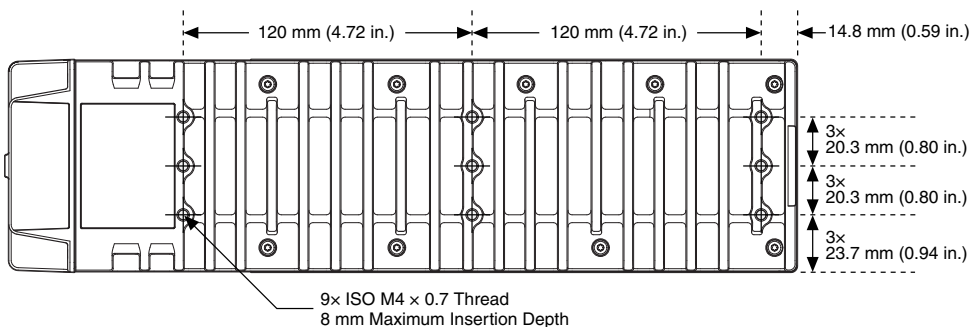

# Mounting the cRIO-9036 on a Panel

You can use the NI panel mounting kit to mount the cRIO-9036 on a panel.

## What to Use

- cRIO-9036
- Screwdriver, Phillips #2
- NI panel mounting kit, 157267-01
  - Panel mounting plate
  - M4 x 10 screws (x6)

## What to Do

Complete the following steps to mount the cRIO-9036 on a panel.

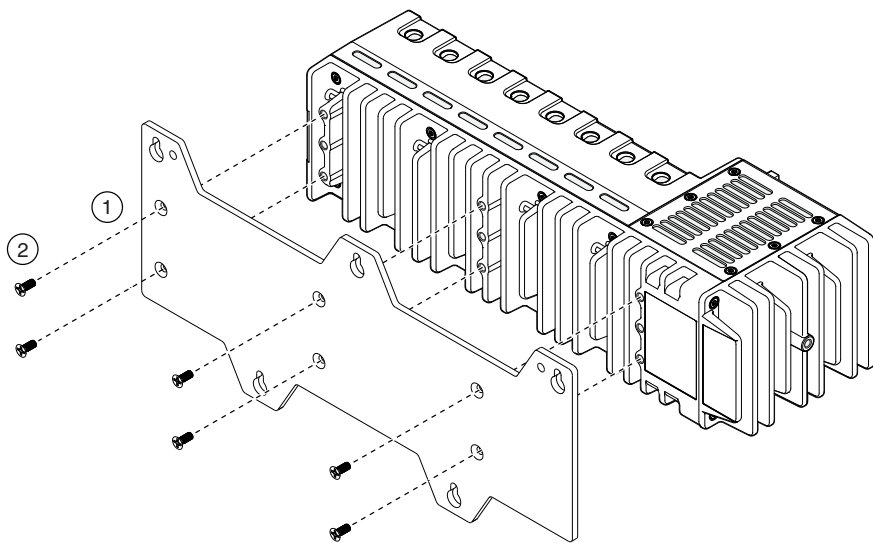

1. Align the cRIO-9036 and the panel mount plate.
2. Fasten the panel mounting plate to the cRIO-9036 using the screwdriver and M4 x 10 screws. Tighten the screws to a maximum torque of  $1.3 \text{ N} \cdot \text{m}$  ( $11.5 \text{ lb} \cdot \text{in.}$ ).

You must use the screws provided with the NI panel mounting kit because they are the correct depth and thread for the panel mounting plate.

3. Fasten the panel mounting plate to the surface using the screwdriver and screws that are appropriate for the surface. The maximum screw size is M5 or number 10.

## Panel Mounting Dimensions

The following figure shows the panel mounting dimensions for the cRIO-9036.

**Figure 15. cRIO-9036 Panel Mounting Dimensions**

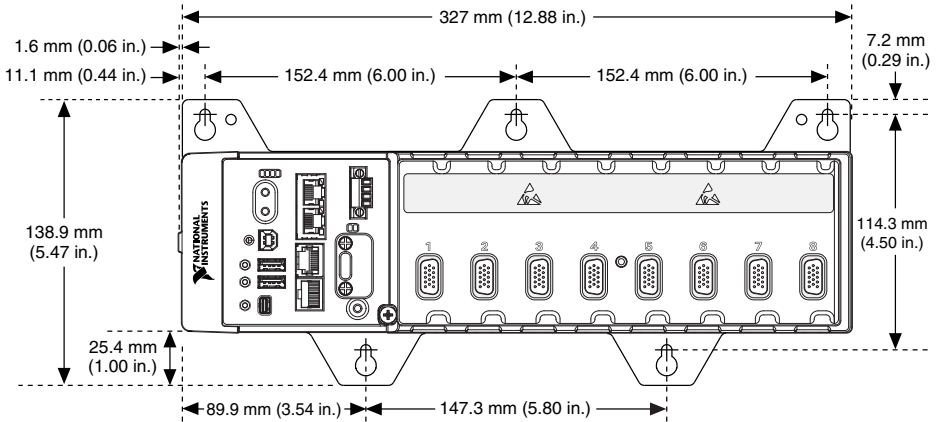

## Mounting the cRIO-9036 on a DIN Rail

You can use the NI DIN rail mounting kit to mount the cRIO-9036 on a standard 35-mm DIN rail.

### What to Use

- cRIO-9036
- Screwdriver, Phillips #2
- NI DIN rail mounting kit, 157268-01
  - DIN rail clip
  - M4 × 10 screws (x3)

### What to Do

Complete the following steps to mount the cRIO-9036 on a DIN rail.

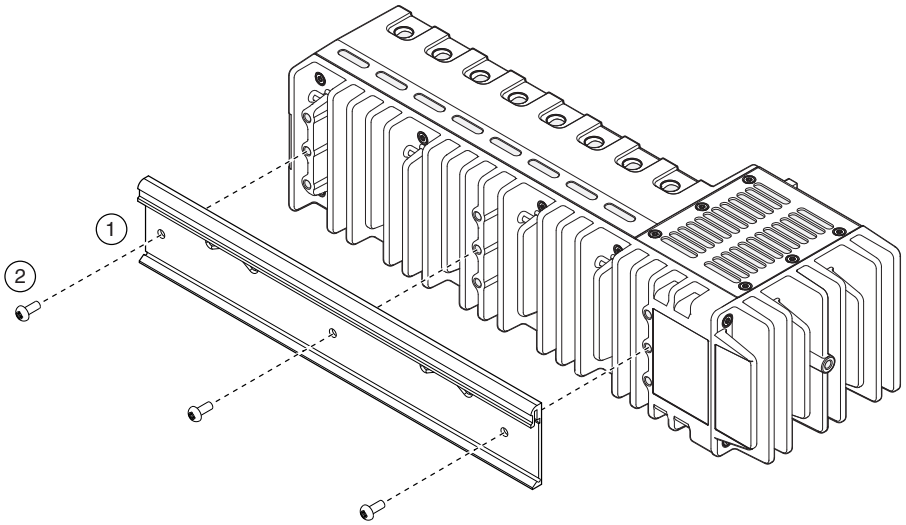

1. Align the cRIO-9036 and the DIN rail clip.
2. Fasten the DIN rail kit to the cRIO-9036 using the screwdriver and M4 × 10 screws. Tighten the screws to a maximum torque of 1.3 N · m (11.5 lb · in.).

You must use the screws provided with the NI DIN rail kit because they are the correct depth and thread for the DIN rail clip.

## Clipping the Device on a DIN Rail

Complete the following steps to clip the cRIO-9036 on a DIN rail.

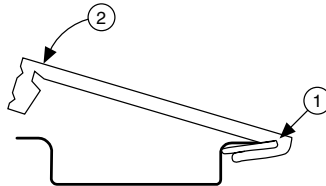

1. Insert one edge of the DIN rail into the deeper opening of the DIN rail clip.
2. Press down firmly to compress the spring until the clip locks in place on the DIN rail.



**Caution** Ensure that no C Series modules are in the cRIO-9036 before removing it from the DIN rail.

## Mounting the Device on a Rack

You can use the following rack mount kits to mount the cRIO-9036 and other DIN rail-mountable equipment on a standard 482.6 mm (19 in.) rack.

- NI Sliding Rack-Mounting Kit, 779102-1
- NI Rack-Mounting Kit, 781989-01



**Note** You must use the NI DIN rail mounting kit, 157268-01, in addition to a rack-mounting kit.

## Mounting the Device on a Desktop

You can use the NI desktop mounting kit to mount the cRIO-9036 on a desktop.

### What to Use

- cRIO-9036
- Screwdriver, Phillips #2
- NI desktop mounting kit, 779473-01
  - Desktop mounting brackets (x2)

### What to Do

Complete the following steps to mount the cRIO-9036 on a desktop.

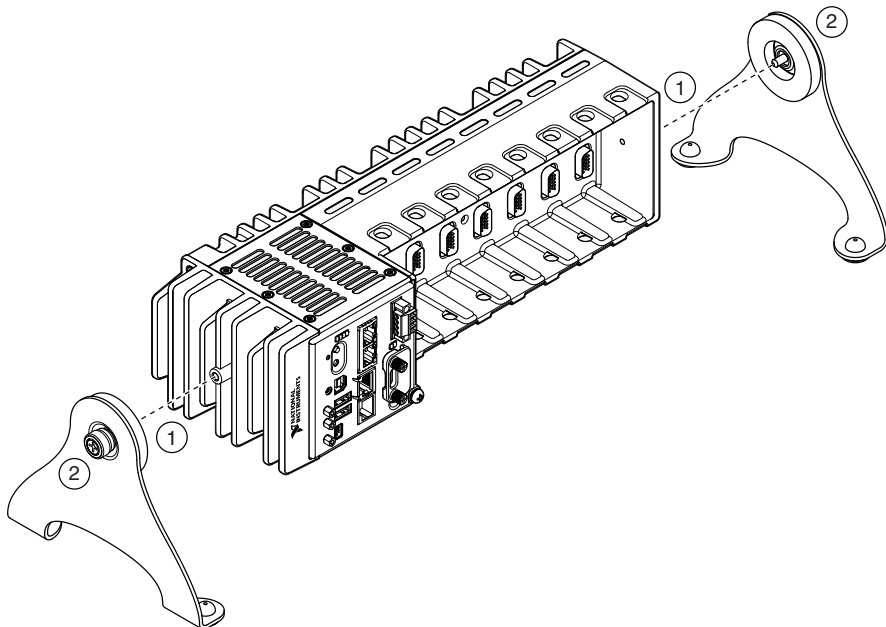



1. Align the brackets with the mounting holes on the ends of the cRIO-9036.
2. Use the screwdriver to tighten the captive screws on the end of the brackets.

## Desktop Mounting Dimensions

The following figures show the desktop mounting dimensions for the cRIO-9036.

**Figure 16. cRIO-9036 Desktop Mounting Front Dimensions**

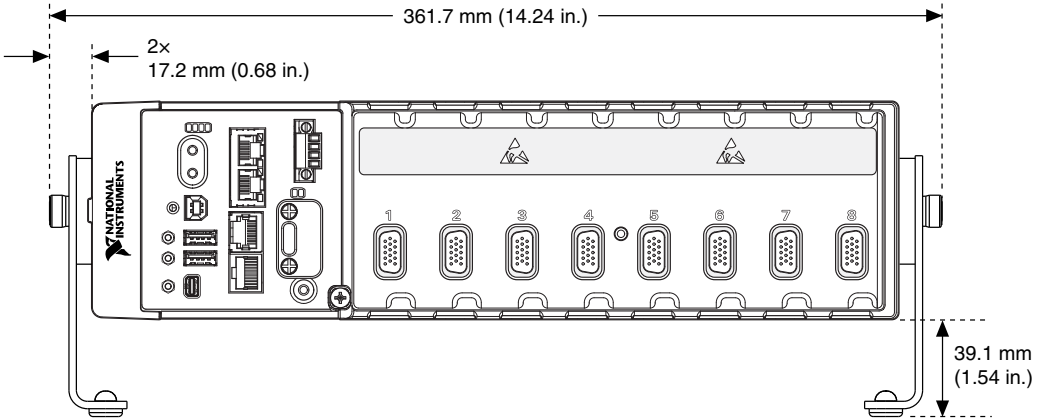

**Figure 17. cRIO-9036 Desktop Mounting Side Dimensions**

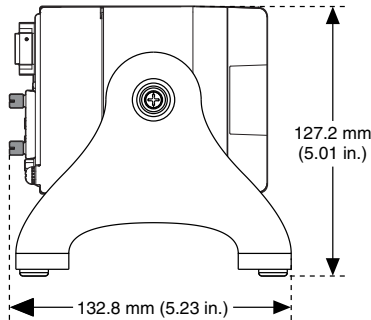

## BIOS Configuration

### Resetting the System CMOS and BIOS Settings

The cRIO-9036 BIOS configuration information is stored in a nonvolatile memory location that does not require a battery to preserve the settings. Additionally, the BIOS optimizes boot time by saving specific system information to memory backed up by a battery (CMOS).

Complete the following steps to reset the CMOS and reset the BIOS settings to factory default values.

1. Disconnect power from the cRIO-9036.
2. Press the CMOS reset button and hold it for 1 second.
3. Reconnect power to the cRIO-9036.

The BIOS `Reset Detected` warning message appears onscreen.



**Note** If the CMOS battery is dead, the CMOS reset button will not work.

## Power-On Self Test Warning Messages

The cRIO-9036 POST displays warning messages for specific issues onscreen. You can use MAX to enable Console Out to send these warning messages through the RS-232 serial port.

The POST can display the following warning messages:

- BIOS Reset Detected—This warning is displayed when the CMOS Reset button has been pushed. This warning indicates that the BIOS settings have the default values.
- CMOS Battery Is Dead—This warning is displayed when the CMOS battery is dead and must be replaced. The BIOS settings are preserved even when the CMOS battery is dead, but the system will boot very slowly because the BIOS cannot optimize boot time by saving specific system information to CMOS.

## BIOS Setup Utility

Use the BIOS setup utility to change configuration settings and to enable special functions. The cRIO-9036 ships with configuration settings that work for most applications, but you can use the BIOS setup utility to change configuration settings to meet the needs of your application.

Changing BIOS settings can cause incorrect behavior, including failure to boot. In general, do not change a setting unless you are sure what the setting does. Reset the BIOS settings to restoring the default configuration settings.

## Launching the BIOS Setup Utility

Complete the following steps to launch the BIOS setup utility.

1. Connect a video monitor to the Mini DisplayPort connector on the cRIO-9036.
2. Connect a USB keyboard to one of the USB host ports on the cRIO-9036.
3. Power on or reboot the cRIO-9036.
4. Hold down either the <F10> key or the <Del> key until `Please select boot device:` appears onscreen.
5. Use the Down Arrow key to select **Enter Setup** and press <Enter>. The setup utility loads after a short delay.

The Main setup menu is displayed when you first enter the BIOS setup utility.

## BIOS Setup Utility Keyboard Navigation

Use the following keys to navigate through the BIOS setup utility:

**Table 21.** Navigation Keys

Key(s)	Function(s)
Left Arrow, Right Arrow	Move between the different setup menus. If you are in a submenu, these keys have no effect, and you must press <Esc> to leave the submenu first.
Up Arrow, Down Arrow	Move between the options within a setup menu.
<Enter>	Enter a submenu or display all available settings for a highlighted configuration option.
<Esc>	Return to the parent menu of a submenu. At the top-level menus, this key serves as a shortcut to the Exit menu.
<+>, <->	Cycle between all available settings for a selected configuration option.
<Tab>	Select time and date fields.
<F9>	Load the optimal default values for all BIOS configuration settings. The optimal default values are the same as the shipping configuration default values.
<F10>	Save settings and exits the BIOS setup utility.

## Main Setup Menu

The Main setup menu reports the following configuration information:

- BIOS Version and Build Date—These values indicate the version of the controller BIOS and the date on which the BIOS was built.
- Embedded Firmware Version—This value identifies the built-in hardware capabilities.
- Processor Type, Base Processor Frequency, and Active Processor Cores—These values indicate the type of processor used in the controller, the speed of the processor, and the number of active processor cores.
- Total Memory—This value indicates the size of system RAM detected by the BIOS.

The Main setup menu also includes the following settings:

- System Date—This setting controls the date, which is stored in a battery-backed real-time clock. Most operating systems also include a way to change this setting. Use <+> and <-> in conjunction with <Enter> and <Tab> to change these values.
- System Time—This setting controls the time of day, which is stored in a battery-backed real-time clock. Most operating systems also include a way to change this setting. Use <+> and <-> in conjunction with <Enter> and <Tab> to change these values.

## Advanced Setup Menu

The Advanced setup menu contains BIOS settings that do not require modification for normal operation of the cRIO-9036. If you have specific problems, such as unbootable disks or resource conflicts, you may need to examine the settings in this menu.



**Caution** Changing settings in the Advanced setup menu may result in an unstable or unbootable controller. If this happens, restore BIOS settings to the factory defaults.

The Advanced setup menu includes the following submenus:

- Power/Wake Configuration Submenu
- SATA Configuration Submenu
- USB Configuration Submenu

### Power/Wake Configuration Submenu

The Power/Wake configuration submenu contains the power and wake settings for the chipset and cRIO-9036. The factory default settings provide the most compatible and optimal configuration.

- **Restore After Power Loss**—This setting specifies the power state that the cRIO-9036 should return to after DC power is lost. Valid values are **Stay Off** and **Turn On**. The default value is **Turn On**. When set to **Stay Off**, the cRIO-9036 returns to the soft off power state after AC power is restored. When set to **Turn On**, the cRIO-9036 powers on when DC power is restored.
- **Power Button Off Behavior**—This setting specifies how the system responds to the power button. Valid options are **Normal** and **Disabled**. The default value is **Normal**. If the value is **Normal**, the system responds to the power button as defined by the OS. If the value is **Disabled**, pressing the power button has no effect when the system is on. When the system is in the soft off state, pushing the power button always powers on the system.
- **Ring Indicator Wake**—This setting enables or disables the ability to wake a powered-off system using the Ring Indicator pin of the RS-232 serial port. The default value is **Disabled**.

### SATA Configuration Submenu

The SATA configuration submenu contains the hard disk drive (HDD) interfaces settings. The factory default settings provide the most compatible and optimal configuration.

- **SATA Controller(s)**—This setting specifies whether the onboard SATA controller is enabled or disabled. The default value is **Enabled**.
- **Onboard Storage**—This item displays the onboard drive detected in the system.

## USB Configuration Submenu

The USB configuration submenu contains the USB host ports settings. The factory default settings provide the most compatible and optimal configuration.

- USB Devices—This item lists the total number of devices detected in the system, categorized by device type.
- Legacy USB Support—This setting specifies whether legacy USB support is enabled. Legacy USB support refers to the ability to use a USB keyboard and mouse during system boot or in a legacy operating system such as DOS.
- Overcurrent Reporting—This setting allows the BIOS to notify the operating system about any USB ports that source too much current. The default value is **Disabled**. Hardware overcurrent protection is always active and cannot be disabled.
- Transfer Timeout—This setting specifies the timeout value for Control, Bulk, and Interrupt USB transfers. The default value is **20** seconds.
- Device Reset Timeout—This setting specifies the number of seconds the POST waits for a USB mass storage device to start. The default value is **20** seconds.
- Device Power-Up Delay—This setting specifies the maximum time a device takes before enumerating. Valid options are **Auto** and **Manual**. The default value is **Auto**. When set to **Auto**, a root port is granted 100 ms, and the delay value of a hub port is assigned from the hub descriptor.
- Device Power-Up Delay in Seconds—This setting specifies the number of seconds the POST waits for a USB device or hub to power on. This setting is only visible when the Device Power-Up Delay is set to **Manual**. The default value is **5** seconds.
- Emulation Type—This setting specifies how the BIOS presents the USB mass storage device to the system for each detected USB mass storage device. This option presents a USB mass storage device as a floppy, Zip, hard disk, or CD-ROM drive. The default value is **Auto**, which allows the BIOS to treat small USB flash disk drives as floppy drives and larger USB flash disk drives as hard disk drives.

## Boot Setup Menu

The Boot Setup menu contains setting related to the boot process and the boot device priority.

- Boot Settings Configuration Submenu—This item accesses the Boot Settings Configuration submenu.
- PXE Network Boot—This setting specifies whether the PXE network boot agent is enabled. The Intel Boot Agent is visible in the Boot Option Priorities menu when enabled, allowing you to boot from a PXE server on the local subnet. The Intel Boot Agent device names are preceded by IBA GE Slot 0200 v1553 in the Boot Option Priorities menu. The system must be restarted for this setting to take effect. The default value is **Disabled**.
- Boot Option Priorities—These settings specify the order in which the BIOS checks for bootable devices, including the local hard disk drive, removable devices such as USB

flash disk drives or USB CD-ROM drives, or the PXE network boot agent. The BIOS first attempts to boot from the device associated with 1st Boot Device, followed by 2nd Boot Device and 3rd Boot Device. If multiple boot devices are not present, the BIOS setup utility does not display all of these configuration options. To select a boot device, press <Enter> on the desired configuration option and select a boot device from the resulting menu. You can also disable certain boot devices by selecting **Disabled**.



**Note** Only one device of a given type is shown in this list. If more than one device of the same type exists, use the appropriate device BBS priorities submenu to re-order the priority of devices of the same type.

The Boot Setup menu displays the following submenus when one or more bootable devices of the corresponding type is present:

- Hard Drive BBS Priorities Submenu
- CD/DVD ROM Drive BBS Priorities Submenu
- Floppy Drive BBS Priorities Submenu
- Network Device BBS Priorities Submenu

## Boot Settings Configuration Submenu

The Boot Settings Configuration submenu applies alternate configurations to boot settings. The factory default settings provide the most compatible and optimal configuration.

- Setup Prompt Timeout—This setting specifies the number of seconds the system waits for a BIOS Setup menu keypress (the <Delete> key). The default value is **2** seconds.
- Bootup NumLock State—This setting specifies the power-on state of the keyboard NumLock setting. The default value is **On**.

## Hard Drive BBS Priorities Submenu

The Hard Drive BBS Priorities submenu specifies the boot priority of hard drive devices.

Boot Option #1, Boot Option #2, Boot Option #3—These settings specify that the main Boot Option Priorities list displays the highest priority device. Optionally, each device can be disabled if the device is not used as a boot device.

## CD/DVD ROM Drive BBS Priorities Submenu

The CD/DVD ROM Drive BBS Priorities submenu specifies the boot priority of CD/DVD ROM drive devices.

Boot Option #1, Boot Option #2, Boot Option #3—These settings specify that the main Boot Option Priorities list displays the highest priority device. Optionally, each device can be disabled if the device is not used as a boot device.

## Floppy Drive BBS Priorities Submenu

The Floppy Drive BBS Priorities submenu specifies the boot priority of floppy drive devices.

Boot Option #1, Boot Option #2, Boot Option #3—These settings specify that the main Boot Option Priorities list displays the highest priority device. Optionally, each device can be disabled if the device is not used as a boot device.

## Network Device BBS Priorities Submenu

The Network Device BBS Priorities submenu specifies the boot priority of network devices.

Boot Option #1, Boot Option #2, Boot Option #3—These settings specify that the main Boot Option Priorities list displays the highest priority device. Optionally, each device can be disabled if the device is not used as a boot device.

## Save & Exit Menu

The Save & Exit setup menu contains all available options for exiting, saving, and loading the BIOS default configuration. As an alternative to this menu, press <F9> to load optimal BIOS default settings and <F10> to save changes and exit setup.

The Save & Exit setup menu includes the following settings:

- **Save Changes and Reset**—This setup utility then exits and reboots the cRIO-9036. Any changes made to BIOS settings are stored in NVRAM. The <F10> key also selects this option.
- **Discard Changes and Reset**—Any changes made to BIOS settings during this session of the BIOS setup utility are discarded. The setup utility then exits and reboots the controller. The <Esc> key can also be used to select this option.
- **Save Changes**—Changes made to BIOS settings during this session are committed to NVRAM. The setup utility remains active, allowing further changes.
- **Discard Changes**—Any changes made to BIOS settings during this session of the BIOS setup utility are discarded. The BIOS setup continues to be active.
- **Restore Factory Defaults**—This option restores all BIOS settings to the factory default. This option is useful if the controller exhibits unpredictable behavior due to an incorrect or inappropriate BIOS setting. Notice that any nondefault settings such as boot order, passwords, and so on are also restored to their factory defaults. The <F9> key also selects this option.
- **Save As User Defaults**—This option saves a copy of the current BIOS settings as the User Defaults. This option is useful for preserving custom BIOS setup configurations.
- **Restore User Defaults**—This option restores all BIOS settings to the user defaults. This option is useful for restoring previously preserved custom BIOS setup configurations.
- **Boot Override**—This option lists all possible bootable devices and allows the user to override the Boot Option Priorities list for the current boot. If no changes have been made to the BIOS setup options, the system will continue booting to the selected device without first rebooting. If BIOS setup options have been changed and saved, a reboot will be required and the boot override selection will not be valid.

# Worldwide Support and Services

---

The NI website is your complete resource for technical support. At [ni.com/support](https://ni.com/support), you have access to everything from troubleshooting and application development self-help resources to email and phone assistance from NI Application Engineers.

Visit [ni.com/services](https://ni.com/services) for NI Factory Installation Services, repairs, extended warranty, and other services.

Visit [ni.com/register](https://ni.com/register) to register your NI product. Product registration facilitates technical support and ensures that you receive important information updates from NI.

A Declaration of Conformity (DoC) is our claim of compliance with the Council of the European Communities using the manufacturer's declaration of conformity. This system affords the user protection for electromagnetic compatibility (EMC) and product safety. You can obtain the DoC for your product by visiting [ni.com/certification](https://ni.com/certification). If your product supports calibration, you can obtain the calibration certificate for your product at [ni.com/calibration](https://ni.com/calibration).

NI corporate headquarters is located at 11500 North Mopac Expressway, Austin, Texas, 78759-3504. NI also has offices located around the world. For telephone support in the United States, create your service request at [ni.com/support](https://ni.com/support) or dial 1 866 ASK MYNI (275 6964). For telephone support outside the United States, visit the *Worldwide Offices* section of [ni.com/niglobal](https://ni.com/niglobal) to access the branch office websites, which provide up-to-date contact information, support phone numbers, email addresses, and current events.



Information is subject to change without notice. Refer to the *NI Trademarks and Logo Guidelines* at [ni.com/trademarks](http://ni.com/trademarks) for information on NI trademarks. Other product and company names mentioned herein are trademarks or trade names of their respective companies. For patents covering NI products/technology, refer to the appropriate location: **Help»Patents** in your software, the `patents.txt` file on your media, or the *National Instruments Patent Notice* at [ni.com/patents](http://ni.com/patents). You can find information about end-user license agreements (EULAs) and third-party legal notices in the `readme` file for your NI product. Refer to the *Export Compliance Information* at [ni.com/legal/export-compliance](http://ni.com/legal/export-compliance) for the NI global trade compliance policy and how to obtain relevant HTS codes, ECCNs, and other import/export data. NI MAKES NO EXPRESS OR IMPLIED WARRANTIES AS TO THE ACCURACY OF THE INFORMATION CONTAINED HEREIN AND SHALL NOT BE LIABLE FOR ANY ERRORS. U.S. Government Customers: The data contained in this manual was developed at private expense and is subject to the applicable limited rights and restricted data rights as set forth in FAR 52.227-14, DFAR 252.227-7014, and DFAR 252.227-7015.

© 2015—2019 National Instruments. All rights reserved.

375695D-03 January 22, 2019