

---

# Calibration Executive User Manual

---

2024-10-11



# Contents

Welcome to the Calibration Executive User Manual .....	9
Calibration Executive Overview .....	10
Calibration Executive Operating Requirements .....	12
Calibration Executive User Interface .....	15
Menu Bar .....	16
Automated Mode Versus Manual Mode .....	18
Upgrade Considerations .....	19
Specifications .....	21
New Features and Changes .....	22
Calibration Executive Device and Module Compatibility .....	30
Launching Calibration Executive and Logging In .....	37
Adding a New User .....	37
Modifying User Names or Passwords .....	38
Deleting a User .....	39
Configuring Audio Notifications .....	40
Configuring Report Options .....	41
Configuring Database Options .....	44
Launching a Calibration Procedure .....	45
Launching the Setup Wizard .....	45
Entering the Customer Information .....	46
Selecting the Required Standards .....	47
Configuring and Using Tracking Numbers .....	49
Entering Environmental Information and Selecting Options .....	51
Selecting a DUT .....	54
Run-Time Dialog Boxes .....	55
Viewing a Calibration Report .....	59
Calibration Reports .....	59
Calibration Reports Database .....	61
Saving a Calibration Reports Database Backup .....	62
Merge Reports .....	63
Edit Report Attributes .....	64
Custom Report Configurator .....	65

Create a New Report Configuration .....	67
Import an Existing Report Configuration .....	68
Rename or Delete Report Configurations.....	69
Customize Report Configuration Design.....	69
Configure Uncertainty and Guard Band Options .....	70
Additional Options.....	71
Frequently Asked Questions .....	72
Understanding the CAL-5501 Calibration Certificate .....	73
Measurement Uncertainty .....	74
Example: Calculating the Uncertainty for a Test Point.....	83
Measurement Guard Banding and TUR Support.....	84
Calibration Procedures .....	93
C Series Module Calibration Procedures.....	93
NI 9201/9221 Calibration Procedure .....	93
NI 9202 Calibration Procedure .....	95
NI 9203 Calibration Procedure .....	97
NI 9205/9206 Calibration Procedure .....	99
NI 9207 Calibration Procedure .....	102
NI 9208 Calibration Procedure .....	104
NI 9209 Calibration Procedure .....	106
NI 9210 Calibration Procedure .....	108
NI 9211 Calibration Procedure .....	110
NI 9212 Calibration Procedure .....	112
TB-9212 Calibration Procedure.....	116
NI 9213 Calibration Procedure .....	120
NI 9214 Calibration Procedure .....	122
TB-9214 Calibration Procedure.....	125
NI 9215 Calibration Procedure .....	128
NI 9216/9226 Calibration Procedure .....	130
NI 9217 Calibration Procedure .....	132
NI 9218 Calibration Procedure .....	134
NI 9219 Calibration Procedure .....	137
NI 2503/2529 Switch Performance Test.....	142
NI 9220 Calibration Procedure .....	145
NI 9222/9223 Calibration Procedure .....	146
NI 9224/9228 Calibration Procedure .....	148

NI 9225/9229/9239 Calibration Procedure .....	150
NI 9227 Calibration Procedure .....	153
Set Current Limits .....	155
NI 9230/9232 Calibration Procedure .....	156
NI 9231 Calibration Procedure .....	158
NI 9234 Calibration Procedure .....	160
NI 9235/9236 Calibration Procedure .....	163
NI 9235/9236 Calibration Setup .....	165
NI 9237 Calibration Procedure .....	167
NI 9238 Calibration Procedure .....	169
NI 9242/9244 Calibration Procedure .....	171
NI 9246/9247 Calibration Procedure .....	173
NI 9250/9251 Calibration Procedure .....	175
NI 9252 Calibration Procedure .....	178
NI 9260 Calibration Procedure .....	180
NI 9262/9263/9264/9265 Calibration Procedure .....	181
NI 9266 Calibration Procedure .....	184
NI 9269 Calibration Procedure .....	186
NI 9361 Calibration Procedure .....	187
Counter/Timer Device Calibration Procedures .....	189
PXIe-6614 Calibration Procedure .....	189
NI 6624 Calibration Procedure .....	192
NI 6652/6653/6672 Calibration Procedure .....	194
PXIe-6674T Calibration Procedure .....	196
PXI-6683/6683H Calibration Procedure .....	198
Data Acquisition (DAQ) Device Calibration Procedures .....	201
Analog Output DAQ Devices .....	201
NI 6703/6704 Calibration Procedure .....	201
NI 671x/672x/673x Calibration Procedure .....	203
NI 6738/6739 Calibration Procedure .....	207
NI 6738/6739 Calibration, Switch Fixture Connection Details .....	211
NI 2503/2529 Switch Performance Test .....	219
B/E/S Series and MIO 62xx/63xx Models Calibration Procedure .....	222
CompactDAQ Chassis Calibration Procedure .....	228
FieldDAQ Devices .....	230
FD-11613/11614 Calibration Procedure .....	230

NI 6349 Calibration Procedure .....	232
Dynamic Signal Acquisition Devices .....	238
USB-4431/4432 Calibration Procedure .....	238
NI 4461/4462/4465 Calibration Procedure .....	241
PXIe-4463 Calibration Procedure .....	244
PXIe-4464 Calibration Procedure .....	249
PXIe-4466/4467/4468 Calibration Procedure .....	254
NI 4472/4474/4472B Calibration Procedure .....	257
NI 4492/4495/4496/4497/4498/4499 Calibration Procedure .....	260
PXIe-4480/4481 Calibration Procedure .....	270
PXIe-4610 Calibration Procedure .....	273
NI Isolated M/S Series Calibration Procedure .....	276
NI R Series Calibration Procedure .....	278
SC Express DAQ Devices .....	281
PXIe-4300 Calibration Procedure .....	281
PXIe-4302/4303/4304/4305 Calibration Procedure .....	283
TB-4302C Calibration Procedure .....	286
PXIe-4309 Calibration Procedure .....	288
PXIe-4310 Calibration Procedure .....	290
PXIe-4322 Calibration Procedure .....	292
PXIe-4330/4331 Calibration Procedure .....	295
PXIe-4339 Calibration Procedure .....	304
RM-4339 Calibration Procedure .....	306
PXIe-4353 Calibration Procedure .....	311
TC-4353 Calibration Procedure .....	315
PXIe-4357 Calibration Procedure .....	317
Performing an Ohms Zero Operation on a Fluke 5520A/5522A Calibrator .....	319
Modular Instruments .....	320
Digital Multimeters (DMMs) .....	320
NI 4065 Calibration Procedure .....	320
NI 4070/4072 Calibration Procedure .....	325
PXI-4071 Calibration Procedure .....	331
DCI Characterization for the NI 4071 Calibration Procedure .....	336
PXIe-4080/4082 Calibration Procedure .....	341
PXIe-4081 Calibration Procedure .....	344

High-Speed Digital I/O .....	347
PXIe-6570/6571 Calibration Procedure .....	347
NI 2503/2529 Switch Performance Test.....	353
High-Speed Digitizers .....	356
NI 5105 Calibration Procedure .....	356
PXIe-5110/5111/5113 Calibration Procedure.....	360
NI 5114 Calibration Procedure .....	365
NI 5122/5124/5142 Calibration Procedure .....	369
USB-5132/5133 Calibration Procedure .....	379
NI 5152/5153/5154 Calibration Procedure .....	382
PXIe-5160/5162 Calibration Procedure .....	387
PXIe-5163 Calibration Procedure .....	395
PXIe-5164 Calibration Procedure .....	404
PXIe-5170R/5171R Calibration Procedure .....	413
PXIe-5172 Calibration Procedure .....	418
PXIe-5185/5186 Calibration Procedure .....	425
PXIe-5622 Calibration Procedure .....	430
PXIe-5624 Calibration Procedure .....	434
NI 5922 Calibration Procedure .....	440
Power Measurement Conditioners.....	443
RM-26999 Calibration Procedure .....	444
Considerations for the Keysight 3458A Digital Multimeter .....	450
Power Supplies and SMUs .....	451
PXI-4110 Calibration Procedure .....	451
PXIe-4112/4113 Calibration Procedure .....	456
PXI-4130 Calibration Procedure .....	462
PXI-4132 Calibration Procedure .....	468
Considerations for the Keysight 3458A Digital Multimeter .....	471
PXIe-4135 and PXIe-4135 (40W) Calibration Procedure.....	472
PXIe-4136/4137 and PXIe-4137 (40W) Calibration Procedure.....	477
PXIe-4138/4139 and PXIe-4139 (40W) Calibration Procedure.....	481
PXIe-4140/4141/4142/4143 Calibration Procedure.....	485
PXIe-4144/4145 Calibration Procedure .....	491
PXIe-414x Resistor Box Characterization.....	495
PXIe-4147 Calibration Procedure .....	500
PXIe-4154 Calibration Procedure .....	504

PXIe-4162/4163 Calibration Procedure .....	508
CAL-4162/4163 with PXI-2520 Switch Fixture Assembly Performance Test .....	513
RMX-412x Calibration Procedure .....	516
RF Devices .....	521
PXIe-5601 Calibration Procedure .....	521
PXIe-5606 Calibration Procedure .....	525
PXIe-5611 Calibration Procedure .....	533
PXIe-5644R/5646R Calibration Procedure .....	536
PXIe-5645R Calibration Procedure .....	543
NI 5650/5651/5652 Calibration Procedure .....	553
PXIe-5653 Calibration Procedure .....	557
PXIe-5654 Calibration Procedure .....	562
PXIe-5654 with PXIe-5696 Calibration Procedure .....	566
PXIe-5655 Calibration Procedure .....	573
PXIe-5663/5663E Calibration Procedure .....	579
PXIe-5665 (3.6 GHz) Calibration Procedure .....	586
PXIe-5665 (14 GHz) Calibration Procedure .....	595
PXIe-5668R Calibration Procedure .....	604
PXIe-5668R Test Equipment (Adjust Only) .....	606
PXIe-5668R Test Equipment (Verification Only) .....	617
PXIe-5667 Calibration Procedure .....	625
PXIe-5673/5673E Calibration Procedure .....	631
PXIe-5693 Calibration Procedure .....	637
PXIe-5698 Calibration Procedure .....	646
PXIe-5840 Calibration Procedure .....	651
PXIe-5841 Calibration Procedure .....	658
PXIe-5842 Calibration Procedure .....	673
NI Wireless Test System (WTS) Calibration Procedure .....	686
Signal Generators .....	690
NI 5402/5406 Calibration Procedure .....	690
PXI-5404 Calibration Procedure .....	693
NI 5412/5421/5422/5441/5442 Calibration Procedure .....	696
PXIe-5413/5423/5433 Calibration Procedure .....	700
PXIe-5450 Calibration Procedure .....	704
PXIe-5451 Calibration Procedure .....	708

PXI Chassis Calibration Procedures .....	713
PXIe-1092 Calibration Procedure .....	714
PXIe-1095 Calibration Procedure .....	715
Semiconductor Test System Calibration Procedures.....	717
STS-DIO-01 Timing CLB Calibration Procedure.....	717
TestScale Module Calibration Procedures .....	724
TS-15000/15010 Calibration Procedure .....	724
TS-15100 Calibration Procedure.....	726
TS-15110 Calibration Procedure.....	730
DMM Instrument Standard Considerations .....	732



# Welcome to the Calibration Executive User Manual

The Calibration Executive User Manual provides detailed descriptions of product functionality and step-by-step processes for use.

## Looking for something else?

For information not found in the User Manual for your product, like specifications or API reference, browse Related Information.

### Related information:

- [Download Calibration Executive](#)
- [License Setup and Activation](#)
- [Calibration Executive Release Notes](#)
- [Calibration Services](#)

# Calibration Executive Overview

Calibration Executive, intended primarily for metrology labs, provides an integrated software environment in which to verify and adjust NI measurement devices.

## Calibration Executive Key Features

Calibration Executive has the following capabilities.

- Externally calibrates many NI measurement devices
- Operates in automated or manual mode
- Configures and controls calibration instruments automatically
- Stores calibration reports in a central database
- Expands as new hardware calibration procedures are added

The Calibration Executive engine provides the core calibration, control, and reporting functionality. Each device calibration procedure provides the calibration routines and automation for a specific measurement device family.

### Related concepts:

- [Calibration Procedures](#)

## Major Components of Calibration Executive

Calibration Executive is designed using NI LabVIEW, IVI, TestStand, and NI-VISA. A core component of Calibration Executive is the calibration engine. This engine, which includes the user interface, communicates with the following drivers and databases to control the calibration process:

- Interchangeable virtual Instruments (IVI)—A software standard for creating a common interface (API) to common test and measurement instruments. The IVI driver communicates with your standards during calibration, typically using GPIB.
- Report Database—A Microsoft Access database that stores the calibration results about assets you have calibrated, such as verification readings taken before and after calibration.

- TestStand—A test executive framework that manages the calibration procedures used to calibrate the asset.

Download the Calibration Executive installer from [ni.com/downloads](https://ni.com/downloads). Refer to ***Installing, Updating, Repairing, and Removing NI Software*** using Package Manager on [ni.com/docs](https://ni.com/docs).

**Related information:**

- [Installing, Updating, Repairing, and Removing NI Software](#)
- [Download Calibration Executive](#)

# Calibration Executive Operating Requirements

Your system must meet the following minimum requirements to run and use Calibration Executive.

- Pentium 4/M processor or equivalent
- 4 GB of RAM
- 1024 x 768 pixels screen resolution
- The user must have administrator privileges
- Windows 10 (64-bit version only)



**Note** Calibration Executive is not compatible with operating systems that use wide characters (for example, Japanese or Chinese). Calibration Executive only supports using periods (.) for decimal places. If your computer is configured to use commas as decimal places, you must change this setting.

## Additional Software Requirements

To view calibration reports in all available formats, you must have the following components installed on your system:

- Java Run-time Environment - Calibration Executive supports both Oracle Java Run-time Environment and OpenJDK.
- Adobe Acrobat Reader
- Microsoft Word
- Microsoft Excel (64-bit is recommended)

The following instruments require specific drivers that are not installed by Calibration Executive. To install these drivers, you must download them directly from the manufacturer's website; you can find links to third party instrument drivers at [ni.com/idnet](http://ni.com/idnet).

Driver versions listed are those tested during development; later versions might be

available and should be compatible.

**Table 1.** Additional driver software requirements

Instrument	Required Drivers
Rohde & Schwarz NRP-Z power meter	<ul style="list-style-type: none"> <li>• NRP-Toolkit 4.16</li> <li>• NRP-NI-VISA Passport 2.7.1</li> <li>• NRP-Z VXI Plug &amp; Play x64 Driver 3.6.0.0</li> </ul>
Rohde & Schwarz SMA100A signal generator	VXIplug&play x64 driver rssma version 2.21.0

If you are performing a calibration that requires a METAS-compatible database, install METAS VNA Tools. Refer to your procedure help page to determine if METAS is required. Visit [metas.ch](https://www.keysight.com/na/en/learning-center/whitepapers/using-metas-vna-tools) for details about the software and to register, then click the **Download METAS VNA Tools** <version> link to download the version of METAS VNA Tools that is compatible with your version of Calibration Executive.

**Table 2.** METAS VNA Tools version compatibility

Calibration Executive Version	METAS VNA Tools Version
2023 Q4 and later	2.7.0

Install METAS VNA Tools using the default installation settings. Ensure you install METAS VNA Tools for everyone to use and in the following folder: `C:\Program Files (x86)\METAS\Metas.Vna.Tools`

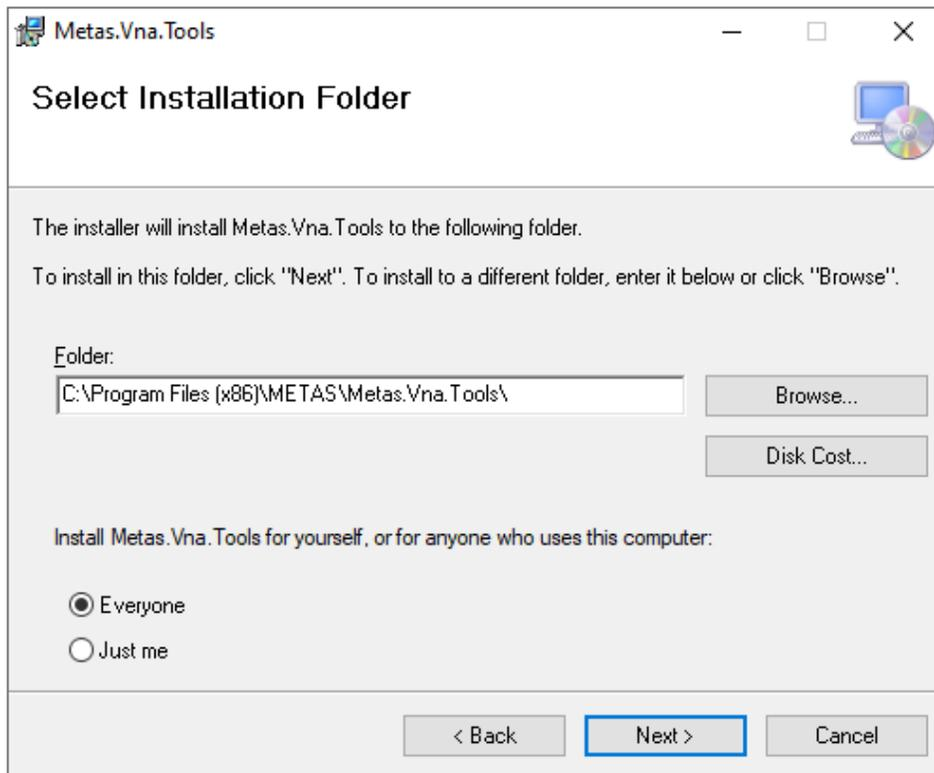

### Related information:

- [metas.ch](http://metas.ch)
- [Download METAS VNA Tools 2.7.0](#)

# Calibration Executive User Interface

The following figure shows the main components of the Calibration Executive user interface. This interface provides access to run calibration procedures; configure users, databases, and calibration reports; and to view the documentation.

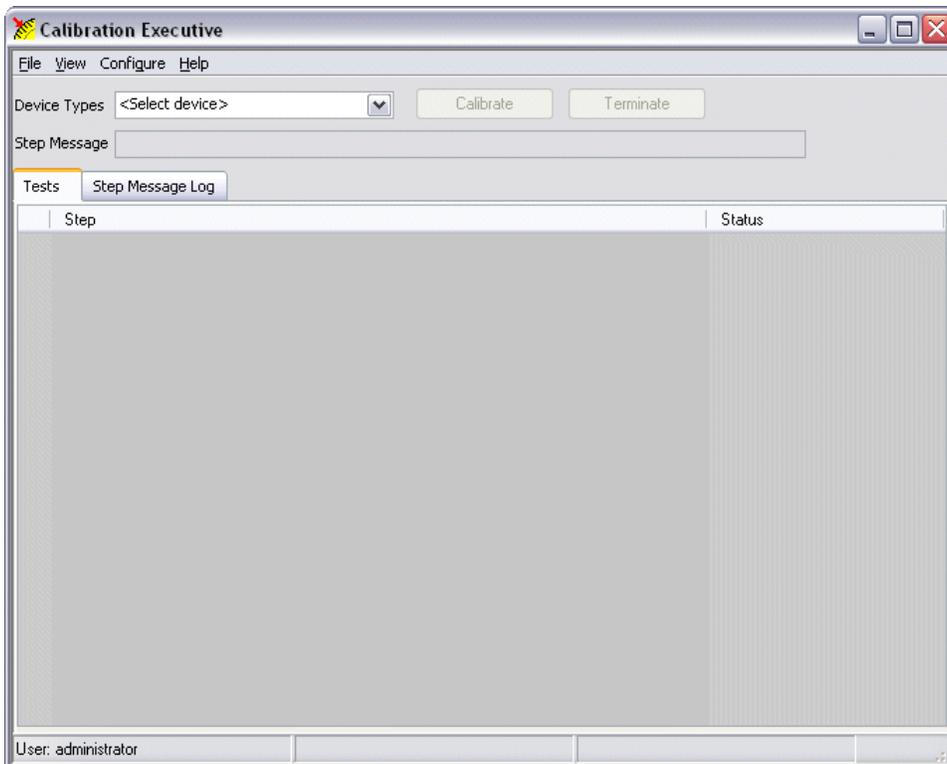

- **Menu bar**—Menu items control the main processes of Calibration Executive.
- **Device Types selector**—Select the device name for the calibration procedure to run.
- **Calibrate button**—Starts the calibration procedure.
- **Terminate button**—Ends the calibration procedure before it completes.
- **Step Message**—Displays status messages from the step that is currently executing.
- **Tests tab**—Displays the step name that is currently running and the status of each step.
- **Step**—Displays which values are currently being verified or adjusted.
- **Status**—Indicates whether a step in the procedure passed or failed.

The following figure shows the Step and Status window during a calibration

procedure. The yellow arrow to the left of the step indicates which step is currently executing.

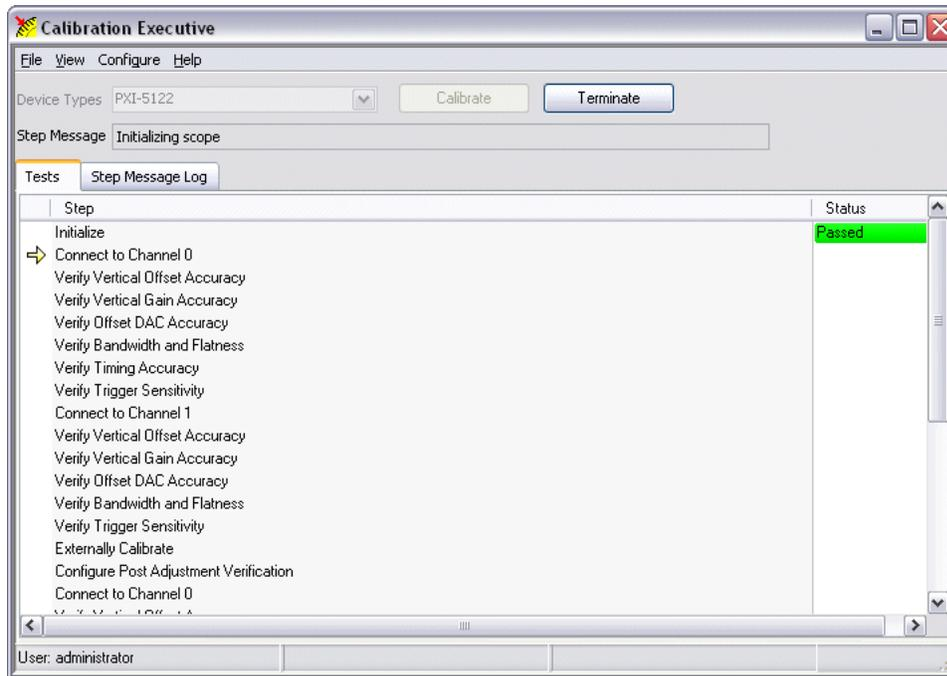

- **Step Message Log tab**—Displays a log of the history of verify test points and their results.

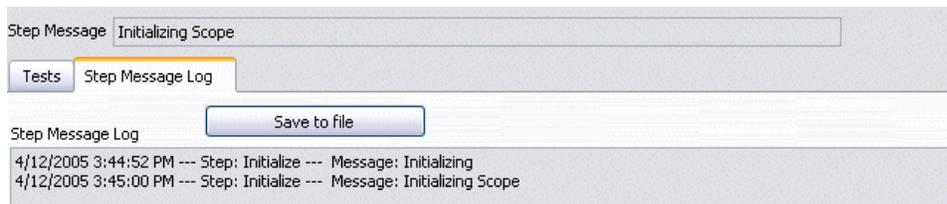

- **Save to file button**—Saves the Step Message Log results in a text file.

## Menu Bar

The Calibration Executive menu bar contains the following four menus.



### File

The File menu contains the following options:

- **Logout**—Logs out the current user and enables the Login selection under the File



menu.

- **Exit**—Closes Calibration Executive.



**Note** If a calibration procedure is currently running, closing Calibration Executive may cause errors. Make sure you click the **Terminate** button before you exit Calibration Executive.

- **Login**—Allows a new user to log in to the application.

## View

The view menu contains the following option.

- **Calibration Reports**—Opens the Calibration Reports window. Use this window to view or delete a stored calibration report.

## Configure

The Configure menu contains the following options.

- **Audio Notifications**—Enables or disables audio notifications in Calibration Executive.
- **Report Options**—Configures how Calibration Executive displays calibration reports.
- **Database Options**—Determines the database that stores calibration reports.
- **Report Database Backup Copy**—Saves a secondary copy of the current calibration reports database.
- **Users**—Allows you to add new users, edit current user profiles, or delete users.

## Help

The Help menu contains the following options:

- **Calibration Executive Help**—Launches this help file.
- **Calibration Procedure Help**—Provides procedure help for the device type selected.
- **About Procedure**—Provides specific information about the procedure used to calibrate the device selected.

- **About Calibration Executive**—Displays the version of Calibration Executive you are using.

#### Related concepts:

- [Viewing a Calibration Report](#)

## Automated Mode Versus Manual Mode

For most devices, Calibration Executive calibrates in either automated or manual mode.

### Automated Mode

If the IVI driver supports the calibration standard(s) you are using or if Calibration Executive provides a custom driver and you have a GPIB card, Calibration Executive automates verification and adjustment by communicating directly with the calibration standards.

### Manual Mode

If you do not have supported standards, you must run the procedure in manual mode. In manual mode, Calibration Executive prompts you to manually control the standards. Calibration Executive then makes the necessary verification and/or adjustment to the device. To enter manual mode, select **Enter Unsupported Instrument** on the Required Standards page when launching a calibration procedure.



**Note** Not all devices are supported in manual mode. Refer to the specific device calibration procedure to check if your device supports manual mode.

#### Related tasks:

- [Selecting the Required Standards](#)

# Upgrade Considerations

Calibration Executive versions 6.0 and later have a new installation path, and the program no longer launches as an administrator application. These changes can render some application database paths invalid after the upgrade. After an upgrade, you might need to manually move some files.

## Upgrading Calibration Executive 5.x to 6.0 and later

If your Report and Uncertainty databases are in their default locations, the setup program will automatically move the databases to the new default location and no action is required.

If databases were moved from their default locations in Calibration Executive 5.x, then Calibration Executive 6.x attempts to reference the current location. If Calibration Executive cannot write to the files in this location, a warning message will be displayed when you first launch Calibration Executive. In this case, you will need to move the files manually to a writable location. After you move the database files, follow the instructions in [Selecting Database Locations](#) to configure the paths for Calibration Executive 6.0 and later.

## Upgrading Calibration Executive 4.x to 6.0 and later

The setup program for Calibration Executive 6.x does not automatically move your Report and Uncertainty databases, even if they are in their default locations. Instead, you will need to move the databases manually to a writable location. After you move the database files, follow the instructions in [Selecting Database Locations](#) to configure the paths for Calibration Executive 6.0 and later.

## Selecting Database Locations

To select the location of your Report database:

1. In the menu bar, select **Configure** » **Database** options.
2. Click the folder icon in the Calibration Executive Configure Report Database dialog, and browse to find the database file.

3. Select the file and click **OK**.
4. Click **OK** to close the dialog box.

To select the location of your Uncertainty database:

1. In the menu bar, select **Configure » Calibration Reports**.
2. In the Calibration Reports window, click **Manage Uncertainty**. The Uncertainty Export/Import window opens.
3. Select **Database Options » Select Database Location**.
4. Use controls in the Select Uncertainty Database File explorer window to locate your uncertainty database file.
5. Select the file, and click **OK**.
6. In the Uncertainty Export/Import window, click **Done**.
7. Click **Close** to close the Calibration Reports window.

# Specifications

To find the specifications of the device you are calibrating, select one of the following methods:

- Visit [ni.com/calibration](https://ni.com/calibration) to find the manual calibration procedure for the device.
- Refer to the hardware documentation for the device. You can download the latest product documentation from [ni.com/docs](https://ni.com/docs).
- Visit [ni.com/products](https://ni.com/products) to find the product data sheet for the device.



**Note** Data sheets for some products contain detailed specs.

## Related information:

- [ni.com/calibration](https://ni.com/calibration)
- [ni.com/docs](https://ni.com/docs)
- [ni.com/products](https://ni.com/products)

# New Features and Changes

Learn about updates—including new features and behavior changes—introduced in each version of Calibration Executive.

## Calibration Executive 2024 Q3 Changes

Learn about new features, behavior changes, and other updates in Calibration Executive 2024 Q3 (24.5).

- Updated the following procedures
  - PXI-4130
  - PXIe-5654 (10 GHz)
  - PXIe-5654 (20 GHz)
  - PXIe-5654 with PXIe-5696 (10 GHz) Adjust Only
  - PXIe-5654 with PXIe-5696 (10 GHz)
  - PXIe-5654 with PXIe-5696 (20 GHz)
  - PXIe-5842
- Removed support for Optional Adjust for the following procedures
  - PXIe-4480
  - PXIe-4481

## Calibration Executive 2024 Q1 Changes

Learn about new features, behavior changes, and other updates in Calibration Executive 2024 Q1 (24.0).

- Added support for the following products
  - PXIe-4466
  - PXIe-4467
  - PXIe-4468
  - PXIe-5841 Analyzer Only
  - PXIe-5841 Generator Only
  - TS-15000
  - TS-15010

- TS-15100
- TS-15110
- Removed support for the following procedures
  - PXIe-6555
  - PXIe-6556
- Updated the following procedures
  - PXI-5650
  - PXI-5651
  - PXI-5652
  - PXIe-5650
  - PXIe-5651
  - PXIe-5652
  - PXIe-5663
  - PXIe-5663E
  - PXIe-5673E 3.3GHz
  - PXIe-5673E 6.6GHz
  - PXIe-5673
  - PXIe-5842

## Calibration Executive 2023 Q4 Changes

Learn about new features, behavior changes, and other updates in Calibration Executive 2023 Q4 (23.8).

- Added support for the following products
  - PXIe-4162
  - PXIe-4162 (10 pA)
  - PXIe-4163
  - PXIe-4163 (10 pA)
  - PXIe-5842
- Removed support for Optional Adjust for the following procedures
  - NI 4135
  - NI 4309
  - NI 5160
  - NI 5162
  - NI 5163
  - NI 5164

- NI 5650
- NI 5651
- NI 5652
- NI 5654
- NI 5663
- NI 5665
- NI 9218
- PXIe-4080
- PXIe-4081
- PXIe-4082
- PXIe-5185
- PXIe-5186
- PXIe-5644R
- PXIe-5646R
- PXIe-5673
- PXIe-5673E
- NI Wireless Test System

## Calibration Executive 2023 Q3 Changes

Learn about new features, behavior changes, and other updates in Calibration Executive 2023 Q3 (23.5).

- Added support for the following products
  - PXIe-4147
  - PXIe-5655
- Removed support for the following procedures
  - NI VB-8012
  - NI VB-8034
  - NI VB-8054
  - PXIe-5632
  - PXI-5691

## Calibration Executive 6.9 Changes

Learn about new features, behavior changes, and other updates in Calibration Executive 6.9.



- Added driver support for Rohde & Schwarz NRP33S Power Sensor
- Added product support for NI 9262

## Calibration Executive 6.8 Changes

Learn about new features, behavior changes, and other updates in Calibration Executive 6.8.

- Added support for the following products
  - PXIe-5163
  - PXIe-5698
- Removed support for the following procedures
  - PXIe-5160 (2CH)
  - PXIe-5160 (4CH)
  - PXIe-5162 (2CH)
  - PXIe-5162 (4CH)
  - PXIe-5164
  - PXIe-5650
  - PXIe-5651
  - PXIe-5652
  - PXIe-5663E
  - PXIe-5673E 3.3GHz
  - PXIe-5673E 6.6GHz
- Removed NI USB-5681 calibration procedure support
- Removed NI USB-5684 power meter standard support

## Calibration Executive 6.7 Changes

Learn about new features, behavior changes, and other updates in Calibration Executive 6.7.

- Added support for the following products
  - FD-11613
  - FD-11614
  - NI 9210
  - NI TB-9212 with mini-TC
  - PXIe-4135 (40W)

- PXIe-4137 (40W)
- Updated the following procedures
  - NI 9219
  - PXIe-4081 (90 day)
  - PXIe-4081 (2 yr)
  - PXIe-4137
  - RM-26999

## Calibration Executive 6.6 Changes

Learn about new features, behavior changes, and other updates in Calibration Executive 6.6.

- Added driver support for Rohde & Schwarz SMA100B signal generator for procedures that previously supported the Rohde & Schwarz SMA100A
- Updated the following procedures
  - PXIe-5160
  - PXIe-5162
  - PXIe-5644R
  - PXIe-5645R
  - PXIe-5646R

## Calibration Executive 6.5 Changes

Learn about new features, behavior changes, and other updates in Calibration Executive 6.5.

- Added product support for the PXIe-4139 (40W)
- Updated the following procedures
  - PXIe-4081 (90 day)
  - PXIe-4081 (2 yr)
  - PXIe-4135
  - PXIe-4139
  - PXIe-5840
  - PXIe-5841
  - NI 9212

## Calibration Executive 6.4 Changes

Learn about new features, behavior changes, and other updates in Calibration Executive 6.4.

- Revised the reporting of guard band values with dB and dBv units on the calibration report
- Import uncertainties from an Open XML spreadsheet using formulas that result in text values
- Added support for the following products
  - PXIe-5841
  - PXIe-5841 (2 yr)
  - RM-26999
- Updated the guard band calculation for uncertainties with dB and dBv units
- Updated the following procedures
  - PCI-4461
  - PXI-4461
  - PXIe-5654 (10 GHz)
  - PXIe-5654 (20 GHz)
  - PXIe-5654 with PXIe-5696 (10 GHz) Adjust Only
  - PXIe-5654 with PXIe-5696 (20 GHz)
  - PXIe-5668 (14 GHz), all bandwidth options
  - PXIe-5840
  - PXIe-5840 (2 yr)
  - NI 9220
  - NI 9263

## Calibration Executive 6.3 Changes

Learn about new features, behavior changes, and other updates in Calibration Executive 6.3.

- Revised formulas for determining measurement uncertainty related to TURs and nominal values
- Updated the TUR calculation for uncertainties with dB and dBv units
- Updated the following procedures
  - PXIe-4135

- PXI-5422

## Calibration Executive 6.2 Changes

Learn about new features, behavior changes, and other updates in Calibration Executive 6.2.

- Added support for the following products
  - PXIe-5624
  - PXIe-5606 Adjust Only
  - PXIe-5668 Adjust Only
  - USB-6346 (Screw Terminal)
  - STS-DIO-01
- Updated the following procedures
  - PXI-4110
  - PCI-5412
  - PXI-5412
  - PCI-5421
  - PXI-5421
  - PXI-5441
  - PXIe-5442
  - PXIe-5653
  - PXIe-5665 (3.6 GHz)
  - PXIe-5665 (3.6 GHz), no pre-amp
  - PXIe-5665 (14 GHz)
  - PXIe-5668 (14 GHz), all bandwidth options
  - PXIe-5668 (26.5 GHz), all bandwidth options

## Calibration Executive 6.1 Changes

Learn about new features, behavior changes, and other updates in Calibration Executive 6.1.

- Added support for the following products
  - NI 9224
  - NI 9228

## Calibration Executive 6.01 Changes

Learn about new features, behavior changes, and other updates in Calibration Executive 6.01.

- A critical bug in the Verify ALC Limits Table test was fixed, enabling the following devices to be verified and adjusted
  - PXI-5650
  - PXIe-5650
  - PXI-5651
  - PXIe-5651
  - PXI-5652
  - PXIe-5652
  - PXIe-5663
  - PXIe-5663E
  - PXIe-5673
  - PXIe-5673E

## Calibration Executive 6.0 Changes

Learn about new features, behavior changes, and other updates in Calibration Executive 6.0.

- Uncertainty and guard band options in custom report configurations
- Added support for the following products
  - PXIe-6349
  - USB-6349
  - NI 9202
  - NI 9252
- Added adjustment support for NI 9203
- Modified audio notifications can only be enabled or disabled; there are no additional options to be configured
- Removed support for 32-bit OS calibration procedures

# Calibration Executive Device and Module Compatibility

The following table provides compatibility information about NI devices and modules that are not supported in this version of Calibration Executive but may be supported in a previous version. If a model is no longer supported, information in this table indicates which version of Calibration Executive is the last to support the device or module.



**Note** Using hardware with unsupported versions of Calibration Executive may result in errors, the inability for your operating system to recognize or detect and then find a driver for your device, or missing devices in Calibration Executive.

**Table 312.** Calibration Executive device and module compatibility

Device or Module	Last Supported in Calibration Executive
AT-5102	3.5.2
AT-AI-16XE-10	3.5.2
AT-MIO-16DE-10	3.5.2
AT-MIO-16E-1	3.5.2
AT-MIO-16E-10	3.5.2
AT-MIO-16E-2	3.5.2
AT-MIO-16XE-10	3.5.2
AT-MIO-16XE-50	3.5.2
AT-MIO-64E-3	3.5.2
DAQCard-4050	3.5.2
DAQCard-4350	3.5.2
DAQCard-5102	3.5.2
DAQCard-AI-16E-4	3.5.2

Device or Module	Last Supported in Calibration Executive
DAQCard-AI-16XE-50	3.5.2
DAQPad-4350	3.5.2
DAQPad-6020E	3.5.2
DAQPad-6020E (BNC)	3.5.2
DAQPad-6052E	3.5.2
DAQPad-6070E	3.5.2
DAQPad-6070E (BNC)	3.5.2
PC-4350	3.5.2
PCI-4060	3.5.2
PCI-4351	3.5.2
PCI-4451	3.5.2
PCI-4452	3.5.2
PCI-4551	3.5.2
PCI-4552	3.5.2
PCI-5102	3.5.2
PCI-5112	3.5.2
PCI-5911	3.5.2
PCI-6601	3.5.2
PCI-6602	3.5.2
PCMCIA-4050	3.5.2
PCMCIA-4350	3.5.2
PCMCIA-5102	3.5.2
PXI-4060	3.5.2
PXI-4351	3.5.2
PXI-5102	3.5.2
PXI-5112	3.5.2
PXI-5600	3.5.2

Device or Module	Last Supported in Calibration Executive
PXI-5620	3.5.2
PXI-6602	3.5.2
PXI-6608	3.5.2
SCXI-1100	3.5.2
SCXI-1120	3.5.2
SCXI-1120D	3.5.2
SCXI-1121	3.5.2
SCXI-1124	3.5.2
USB-5102	3.5.2
WSN-3202	3.6.6
WSN-3212	3.6.6
WSN-3226	3.6.6
NI cDAQ-9172 (USB Chassis)	4.5
DAQCard-6024E	5.2
DAQCard-6036E	5.2
DAQCard-6062E	5.2
DAQCard-6715	5.2
DAQPad-6015 (BNC)	5.2
DAQPad-6015 (Mass Termination)	5.2
DAQPad-6015 (Screw Termination)	5.2
DAQPad-6016	5.2
FP-AI-100	5.2
FP-AI-102	5.2
FP-AI-110	5.2
FP-AI-111	5.2
FP-AI-112	5.2
FP-AIO-600	5.2



Device or Module	Last Supported in Calibration Executive
FP-AIO-610	5.2
FP-AO-200	5.2
FP-AO-210	5.2
FP-RTD-122	5.2
FP-RTD-124	5.2
FP-TC-120	5.2
PCI-6010	5.2
PCI-6011E	5.2
PCI-6013	5.2
PCI-6014	5.2
PCI-6023E	5.2
PCI-6024E	5.2
PCI-6025E	5.2
PCI-6030E	5.2
PCI-6031E	5.2
PCI-6032E	5.2
PCI-6033E	5.2
PCI-6034E	5.2
PCI-6035E	5.2
PCI-6036E	5.2
PCI-6040E	5.2
PCI-6052E	5.2
PCI-6070E	5.2
PCI-6071E	5.2
PCI-6551	5.2
PCI-6552	5.2
PCI-7830R	5.2

Device or Module	Last Supported in Calibration Executive
PCI-7831R	5.2
PCI-7833R	5.2
PCI-AI-16XE-10	5.2
PCI-AI-64XE-10	5.2
PCI-MIO-16E-1	5.2
PCI-MIO-16E-4	5.2
PCI-MIO-16XE-10	5.2
PCI-MIO-16XE-50	5.2
PCI-MIO-64E-1	5.2
PCI-MIO-64XE-10	5.2
PCMCIA-6715	5.2
PXI-4220	5.2
PXI-5610	5.2
PXI-5900	5.2
PXI-6025E	5.2
PXI-6030E	5.2
PXI-6031E	5.2
PXI-6040E	5.2
PXI-6052E	5.2
PXI-6070E	5.2
PXI-6071E	5.2
PXI-6551	5.2
PXI-6552	5.2
PXI-7830R	5.2
PXI-7831R	5.2
PXI-7833R	5.2
PXIe-6555_6556 Switch Fixture	5.2

Device or Module	Last Supported in Calibration Executive
SCXI-1102	5.2
SCXI-1102B	5.2
SCXI-1102C	5.2
SCXI-1104	5.2
SCXI-1104C	5.2
SCXI-1125	5.2
SCXI-1503	5.2
SCXI-1520	5.2
SCXI-1600	5.2
FP-AI-100	5.2
FP-AI-102	5.2
FP-AI-110	5.2
FP-AI-111	5.2
FP-AI-112	5.2
FP-AI-118	5.2
FP-AIO-600	5.2
FP-AIO-610	5.2
FP-AO-200	5.2
FP-AO-210	5.2
FP-RTD-122	5.2
FP-RTD-124	5.2
FP-TC-120	5.2
PXI-5691	6.9.0
PXIe-5632	6.9.0
PXIe-6555	6.9.0
PXIe-6556	6.9.0
VB-8012	6.9.0

Device or Module	Last Supported in Calibration Executive
VB-8034	6.9.0
VB-8054	6.9.0

# Launching Calibration Executive and Logging In

To log in to Calibration Executive, complete the following steps:

1. Launch Calibration Executive by selecting **Start » Programs » National Instruments » Calibration Executive**.
2. In the Login dialog box, select either `administrator` or another user name from the **User Name** control.



3. If you select a user name other than administrator, enter a valid password. If you select administrator, no password is necessary.



**Note** You should change the default administrator password after the initial login. Refer to ***Modifying User Names or Passwords*** for instructions on how to change the default password.

4. Click **OK** to launch the user interface.

## Related tasks:

- [Modifying User Names or Passwords](#)

## Adding a New User

Add and configure a new Calibration Executive user.

1. Navigate to **Configure » Users** to open the Configure Users window.

2. Click **Add**.

3. Enter the user name, full name, comment, and password in the appropriate fields.
4. Re-enter the password in the **Confirm Password** field.
5. Select a profile in the User Profile control to define an initial set of privileges for a new user. The following table shows specific user privileges.

**Table 4.** Calibration Executive user privileges

Feature	Non-Administrator Privilege	Administrator Privilege
Create/edit/delete users	No	Yes
Configure file locations	No	Yes
Delete calibration reports	No	Yes

6. Click **OK** to save your changes.
7. Click **Close** to close the Configure Users window.

## Modifying User Names or Passwords

Change the user name, comments, or password associated with a specific user.

1. Navigate to **Configure » Users** to open the Configure Users window.
2. Highlight the name of the user you want to modify.
3. Click **Edit**.
4. Modify the information you want to change.



**Note** The **Advanced** button displays the Edit Flags dialog box, which contains TestStand property flags you can modify. You need to configure these property flags only when you are developing a relatively sophisticated custom type in TestStand. The **Advanced** button has no function in Calibration Executive.

5. Click **OK** to save your changes.
6. Click **Close** to close the Configure Users window.

## Deleting a User

Remove a user from Calibration Executive.

To delete a user name, complete the following steps.



**Note** You cannot delete your own login information.

1. Navigate to **Configure » Users** to open the Configure Users window.
2. Highlight the name of the user you want to remove.
3. Click **Delete**.
4. Click **Yes** to confirm your changes.
5. Click **Close** to close the Configure Users window.

# Configuring Audio Notifications

Configure your system to notify you when a test needs attention.

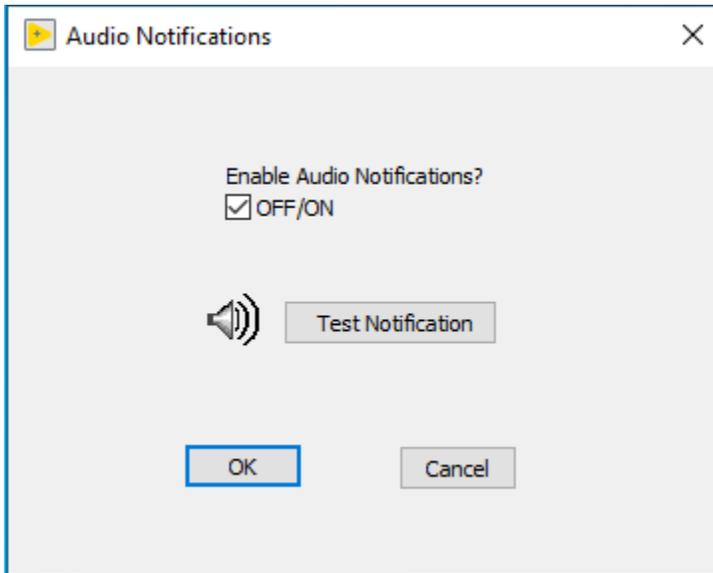

1. Navigate to **Configure » Audio Notifications**.
2. Select or deselect **OFF/ON** under **Enable Audio Notifications?** to enable or disable notifications.
3. Click **Test Notification** to test your audio notification.
4. Click **OK** to save your settings.



# Configuring Report Options

specify the format of the calibration report, the location in which to store calibration reports, and customize the report name.

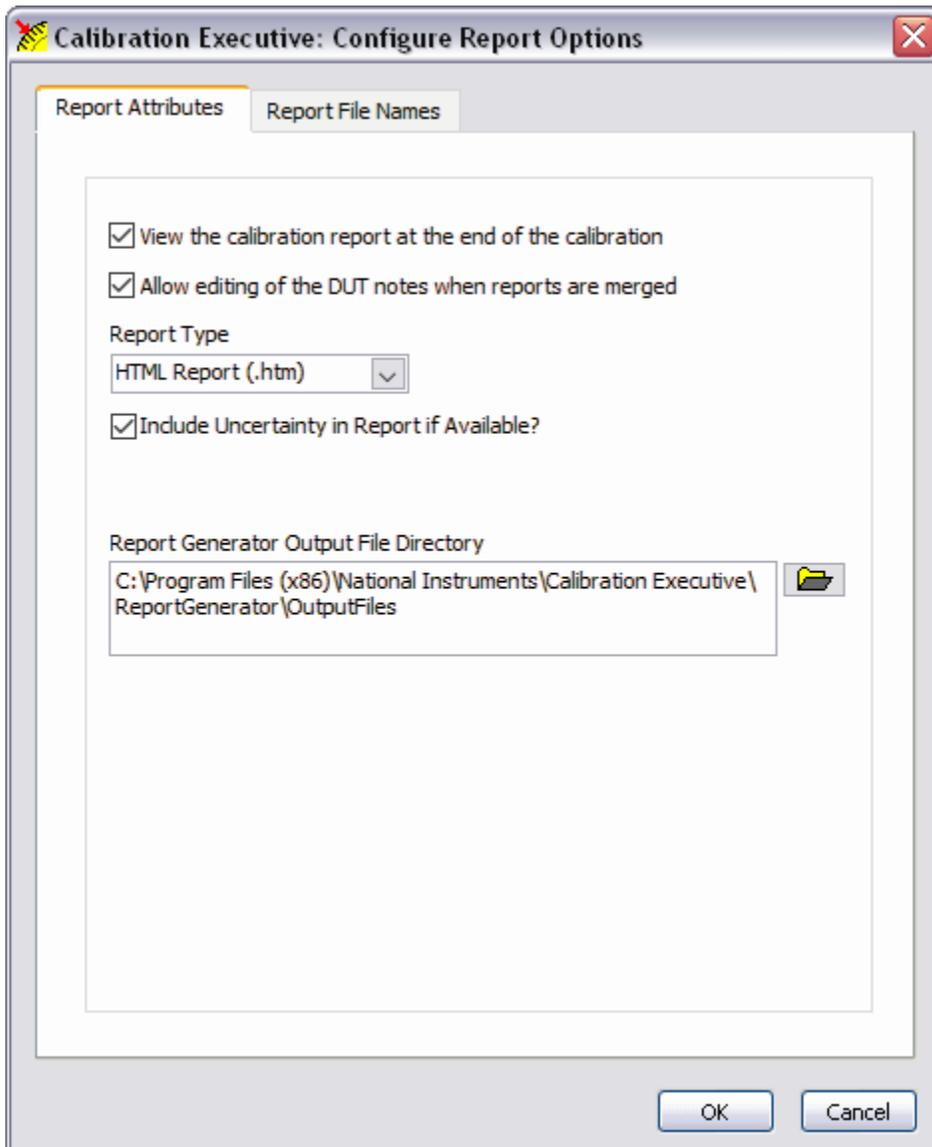

1. Navigate to **Configure » Report Options**.
2. Select a format from the **Report Type** pull-down menu: Text, HTML, PDF, or MS Word.
3. Click the folder icon to the right of the **Report Generator Output File Directory** field to browse for the directory in which to store your calibration reports.

4. Highlight the name of the directory.
5. Click **Select Cur Dir**.
6. Click **OK**.



**Tip** Enable **View calibration report at the end of the calibration** if you want the report to display automatically when the calibration completes. Enable **Allow editing of DUT notes when reports are merged** to edit the DUT notes when merging reports.

## Flexible Report Names

Click the **Report File Names** tab to customize the report name.

Calibration Executive: Configure Report Options

Report Attributes | Report File Names

Items  
Customer Name

Item Separator  
\_ (underline)

Item Order  
Customer Name  
Serial Number  
Calibration Date

Add Remove Move Up Move Down Remove All

Restore Defaults

Preview  
<Customer Name>\_<Serial Number>\_<Calibration Date>.htm

Show with example values

OK Cancel

1. Select an item for the report name using the **Items** pull-down menu.
2. Click **Add** to add the selected item to the report name. Use the **Remove** and **Remove All** buttons to remove any selected items from the report name.
3. Repeat steps 1 and 2 for each item you want to add to the report name.
4. Select a separating character for the report name using the **Item Separator** pull-down menu.
5. Click **Move Up** and **Move Down** to arrange the items in the **Item Order** text box. The preview text box displays the customized report name.



**Tip** Click **Restore Defaults** to restore the default report name.

# Configuring Database Options

Specify the database where Calibration Executive stores calibration reports.

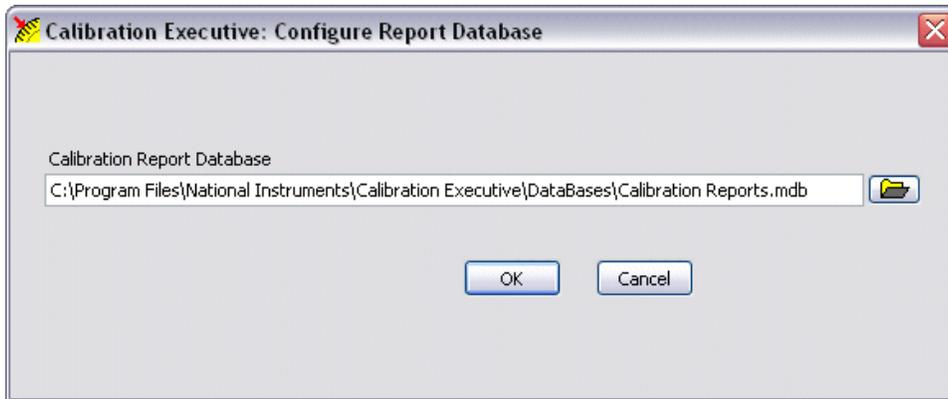

1. Navigate to **Configure » Database options** to launch the Configure Report Database window.
2. Click the folder icon to the right of the **Configure Report Database** field.
3. Search for the new file location.
4. Highlight the name of the file.
5. Click **Open**.
6. Click **OK**.

# Launching a Calibration Procedure

This tutorial teaches you how to launch a calibration procedure in NI Calibration Executive. In this tutorial, you will launch a calibration procedure by completing the following tasks:

1. [Launching the Setup Wizard](#)
2. [Entering the Customer Information](#)
3. [Selecting the Required Standards](#)
4. [Entering Environmental Information and Selecting Options](#)
5. [Selecting a DUT](#)
6. [Run-Time Dialog Boxes](#)

## Launching the Setup Wizard

Complete the following steps to launch the setup wizard.

1. Select the device to calibrate from the **Device Types** control in the upper left corner of the user interface.

Devices connected to your system that have calibration procedure support are listed at the top of the drop-down list. Devices that appear in the list below the break line are selectable, but they reflect devices that are not automatically detected at the launch of Calibration Executive.

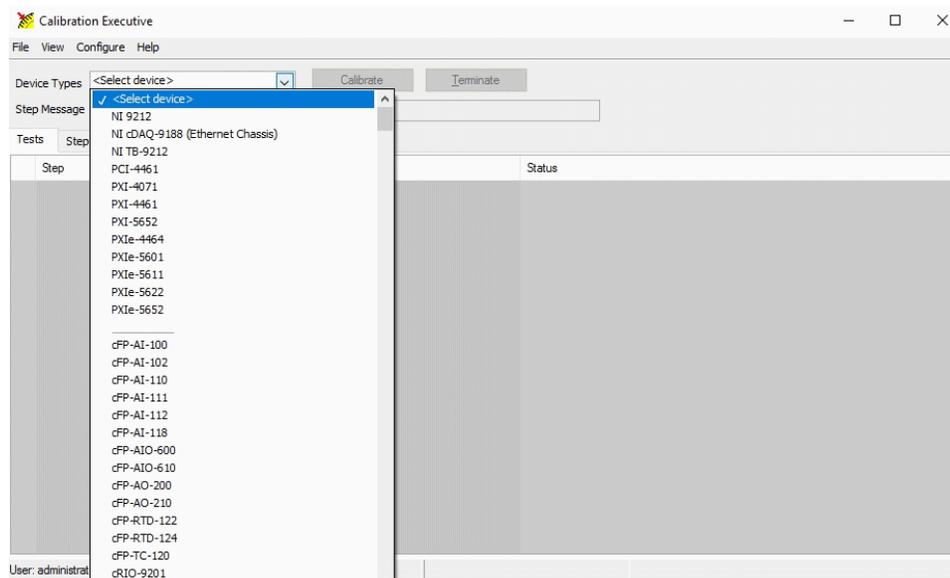

2. Click the **Calibrate** button to launch the setup wizard.

**Related concepts:**

- [Launching a Calibration Procedure](#)

**Related tasks:**

- [Entering the Customer Information](#)

## Entering the Customer Information

1. Enter the customer name and address. Calibration Executive stores this information and retrieves it the next time you begin to enter the customer name.



**Note** To delete a customer entry, begin typing the name in the **Customer Name** field. When a list of matching names appears, use the up/down arrow keys to highlight the name, as shown in the figure below, and press the **Delete** key. Click **Delete** to delete the customer entry from the

database.

2. **Optional:** Enter information in the **Work Order Number** field.
3. Enter any additional relevant information in the **Notes** field.
4. Click **Next**.

**Related tasks:**

- [Launching the Setup Wizard](#)
- [Selecting the Required Standards](#)

## Selecting the Required Standards



**Note** Each calibration instrument required for your selected calibration procedure has its own page. You must complete the required information for each instrument before proceeding to the next page.

1. Select a supported instrument from the supplied list.



**Note** The drop-down list contains several models for each category of instrument; however, only a model specified or recommended in the DUT's procedure has been validated to work for that procedure. Unvalidated models may not be supported in software for the DUT's

procedure and may error out during operation.



**Note** If you select **Enter Unsupported Instrument**, you are prompted to enter additional information about the instrument in the **Description** field.

2. Enter a tracking number for the instrument in the **Tracking No.** field.
3. Select a calibration interval for the instrument from the **Calibration Interval** list box.
4. Select the calibration due date for the selected instrument in the **Calibration Due Date** field. You can either enter the date from the keyboard or click the calendar icon  to launch the time and date dialog box, shown in the following figure.

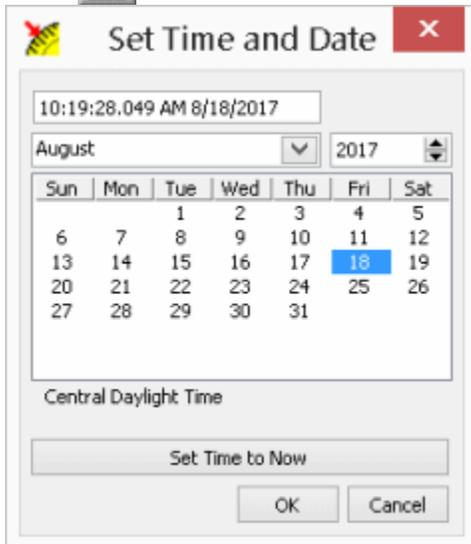

5. Enter any additional comments in the **Notes** field.
6. Select the correct address of the instrument from the **Address** list.



**Note** The **Address** list displays all detected instruments that are connected to your computer. If the address of your instrument is not displayed in the list, ensure that the instrument is connected and click **Refresh**. To run a calibration procedure in automated mode, you must select the instrument and its address.

7. Click **Next** to proceed to the next Required Standards page.
8. When you complete all required standards information, click **Next**.

**Related concepts:**



- [Configuring and Using Tracking Numbers](#)

### Related tasks:

- [Entering the Customer Information](#)
- [Entering Environmental Information and Selecting Options](#)

## Configuring and Using Tracking Numbers

Calibration Executive version 4.1 or later enables you to maintain and view customer-specific tracking numbers using the calibration setup wizard. Two configuration files are created upon the initial launch of Calibration Executive:

- `TrackingNumberFilePath.ini` - Contains path information for the tracking number configuration file. The user can modify the key under the `[TrackingNumberFilePath]` section to set the path of the `TrackingNumbers.ini` file.
- `TrackingNumbers.ini` - Contains hardware serial numbers paired with associated tracking numbers, if entered, in the format `SerialNumber = TrackingNumber`.

When you add or edit a tracking number for a device in the DUT Selection page, Calibration Executive stores the number in the `TrackingNumbers.ini` configuration file. Tracking numbers created or edited in the wizard are committed to the configuration file when the user clicks **Finish** and the calibration session is initiated.

### Setting Up and Configuring the Tracking Number File

The `TrackingNumberPath.ini` configuration file holds a single key under the section `[TrackingNumberFilePath]`, which allows the user to set the path of the tracking number configuration file. The default location as created is `Path = C:\<Program Files>\National Instruments\Calibration Executive\Config\TrackingNumbers.ini`.

The tracking number configuration file can be renamed and relocated as the user chooses, including network locations accessible to multiple computers, and will function as long as the correct path is defined in the

`TrackingNumberFilePath.ini` file. The file must remain a configuration file with the `.ini` file extension.

The tracking number configuration file organizes tracking numbers through pairs of `SerialNumber = TrackingNumber`, where the serial number is as detected in NI-MAX by the system API without leading zeroes.



**Note** Although the serial number detected by NI-MAX typically matches the serial number printed on the board, it is possible for discrepancies to occur. If you experience issues with tracking numbers that are out of sync, or if serial numbers displayed in Calibration Executive do not match those recorded, you might need to modify the serial number in the tracking number configuration file.

You can manually enter device serial numbers in to the tracking number configuration file in one of two ways by editing the `TrackingNumberPath.ini` configuration file directly:

- Enter the serial number/tracking number pair under the `[UserDefined]` section. The setup wizard in Calibration Executive processes tracking numbers associated with detected serial numbers from this section first.
- Enter or modify the associated entry under the section labeled with the product name (for example, `[NI PXIe-4464]`).

Once a calibration setup is completed, entries in the `[UserDefined]` section are automatically moved into sections organized by product name. The following example shows serial number/tracking number pairs for two devices in the `[UserDefined]` section:

```
[UserDefined]
18D771D = "8888"
1A3215A = "1111"
```

After these devices are configured through the setup wizard, the tracking numbers are moved to a product section, and the information is deleted from the `[UserDefined]` section:

```
[NI PXIe-4464]
18D771D = "8888"
1A3215A= "1111"

[UserDefined]
```

In addition, you can create and edit tracking numbers on the DUT Selection page of the calibration setup wizard. Tracking numbers created or edited in the setup wizard are only committed to the tracking number configuration file once the calibration session is initiated after the user clicks **Finish**. Tracking numbers created in the wizard are written directly to the specific product name section of the tracking number configuration file.

## Entering Environmental Information and Selecting Options

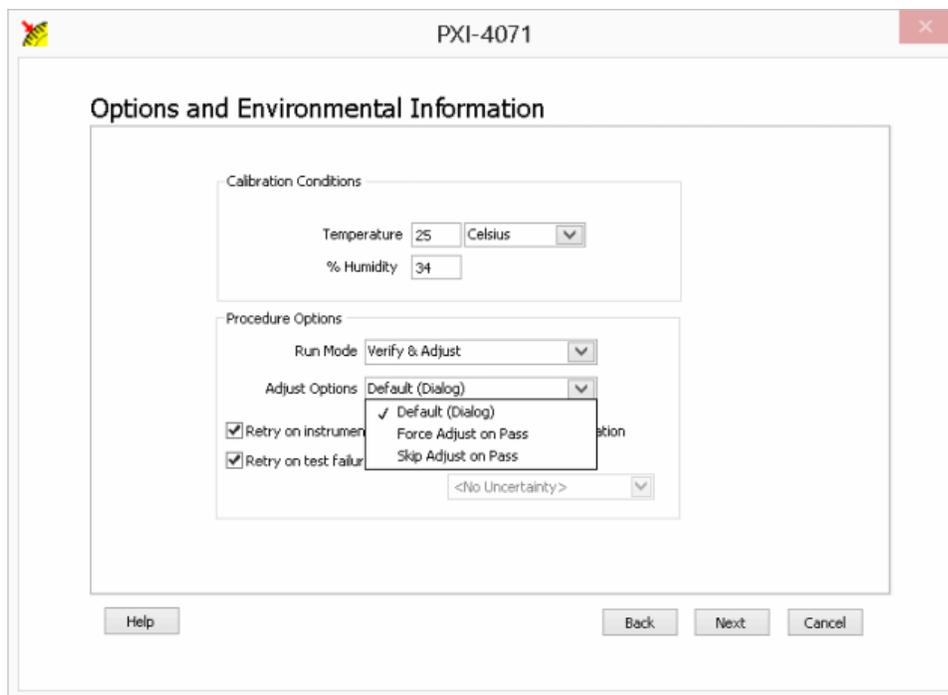

1. In the Calibration Conditions section, enter the ambient temperature and select the temperature unit (Celsius or Fahrenheit).
2. Enter the % Humidity.



**Note** The information you enter in the Calibration Conditions section is

included on the calibration report.

3. In the Procedure Options section, select the **Run Mode**. The modes available vary depending on the device you are calibrating. Refer to the calibration procedure for your device for details on available run modes.

Option	Description
<b>Verify Only</b>	This run mode verifies the device against the specifications. This mode does not adjust the performance of the device.
<b>Verify &amp; Adjust</b>	<p>This run mode verifies the device against the as-found specifications. The procedure then executes a series of steps to adjust the performance of the device. The device will then be re-verified against the as-left specifications.</p> <p>Devices that support this run mode may also support the Optional Adjust feature. Optional Adjust is a feature that allows you to terminate a procedure being executed in Verify &amp; Adjust run mode after the initial verify. After the initial verify, test results are displayed in a pop-up window, allowing you to terminate the procedure without running adjust and generating a report with the initial verify results.</p> <p>If supported, Verify &amp; Adjust also enables you to choose when the device gets adjusted, based on the pass/fail status of the initial as-found pass status. Options include the following:</p> <ul style="list-style-type: none"> <li>◦ <b>Default (Dialog)</b> - After the as-found verification, a dialog appears that lets you choose whether or not to adjust based on the results of the as-found results.</li> <li>◦ <b>Force Adjust on Pass</b> - Adjustment will be performed regardless of the pass/fail status of the as-found verification.</li> <li>◦ <b>Skip Adjust on Pass</b> - If the as-found</li> </ul>

Option	Description
	verification passes the as-left limits, the device will not be adjusted. A failure automatically forces an adjustment.
<b>Adjust Only</b>	This run mode adjusts only the device performance and does not generate any report. This run mode can be used if a Verify Only has already been performed.



**Note** NI recommends performing adjustment every calibration cycle to ensure that the device is operating within specification. Devices must be adjusted prior to re-verification in order to reset the calibration cycle.



**Note** The run mode and adjust options selected for the procedure are stored and retrieved the next time the procedure is run until the mode is changed.

4. Complete any additional fields as needed.



**Note** Not all device procedures present the same Procedure Options. Make sure you complete all required information before proceeding to the next step.

5. Click **Next**.

**Related tasks:**

- [Selecting the Required Standards](#)
- [Selecting a DUT](#)

## Selecting a DUT

The screenshot shows a window titled "PXI-4071" with a "DUT Selection" dialog. The dialog has a "Device Procedure Name" field containing "PXI-4071". Below it is a table with the following data:

DUT	DAQmx Device ID	Name	Location	Serial No	Tracking No
<input checked="" type="checkbox"/> 1	PXI1Slot7	NI PXI-4071	PXI1 Slot7	C71C765	
<input checked="" type="checkbox"/> 2	PXI1Slot8	NI PXI-4071	PXI1 Slot8	Simulated	
<input checked="" type="checkbox"/> 3	PXI1Slot9	NI PXI-4071	PXI1 Slot9	Simulated	
<input checked="" type="checkbox"/> 4	PXI1Slot10	NI PXI-4071	PXI1 Slot10	Simulated	

Below the table is a "Calibrate? Select All/None." checkbox which is checked. There is also a "Notes" text area and buttons for "Help", "Back", "Finish", and "Cancel".

The DUT Selection page displays DUTs detected on the system in an array format, which enables back-to-back calibration of multiple instances of the same model DUTs. Note that the array displays a maximum of four rows of devices at a time; use the scroll bar to view any additional DUTs detected on the system.

The array contains a row for each instance of the DUT detected on the system, and each row contains the following fields:

- **DUT** - Row identifier for an instance of the device under test (DUT). Select this box to enable calibration. Deselect this box to exclude the device from calibration.
- **Device ID** - Unique identifier of the DUT in this device row.
- **Name** - Model name of the DUT in this device row.
- **Location** - Discernable location (if available) of the DUT in this device row.
- **Serial No** - Hardware serial number of the DUT in this device row.
- **Tracking No** - Customer-specific tracking number. Values entered into this field will be cached and recorded for future use.

In the DUT Selection page, do the following:

1. Select the **DUT** row for each device instance to be calibrated, or select **Calibrate?** to

- toggle the selection of all instances.
2. Unless autopopulated, enter the serial number of each device to be calibrated in the appropriate **Serial No** fields.
  3. **Optional:** Enter a tracking number for each device to be calibrated in the appropriate **Tracking No** fields.
  4. Click **Finish** to launch the calibration procedure.

After you launch the procedure, a dialog box appears in which you must enter a device identifier such as a device number, device name, or resource name. This dialog box varies depending on which device you are calibrating.



**Note** In some device procedures, the device identifier is required in the DUT Selection page, rather than in a separate dialog box.

This device identifier is assigned by Measurement & Automation Explorer (MAX) when you configure the hardware in MAX. To find this information, launch MAX, expand **Devices and Interfaces**, and locate the device in the list.

#### Related concepts:

- [Configuring and Using Tracking Numbers](#)

#### Related tasks:

- [Entering Environmental Information and Selecting Options](#)
- [Run-Time Dialog Boxes](#)

## Run-Time Dialog Boxes

Run-Time dialog boxes are shown and described below. During the initial verify, the Test Failed dialog boxes appear for as-found and as-left limit failures, respectively, and will describe the details of each failure. As-left limit failures will not result in an overall test failure during the initial verify, but will allow the user to retry the test point if failures are a result of setup issues.

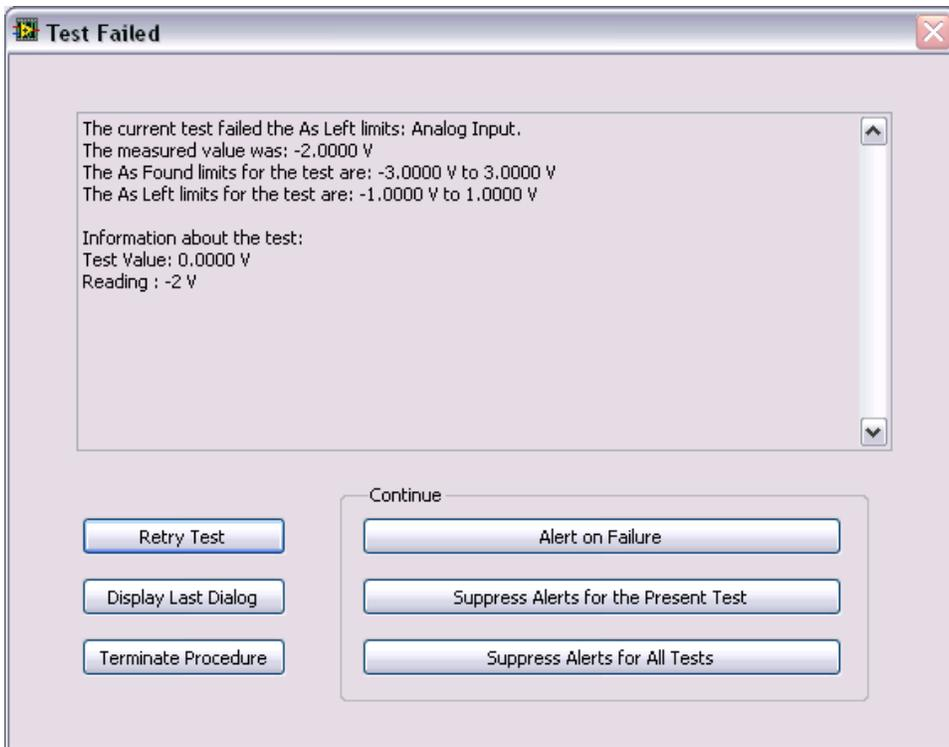
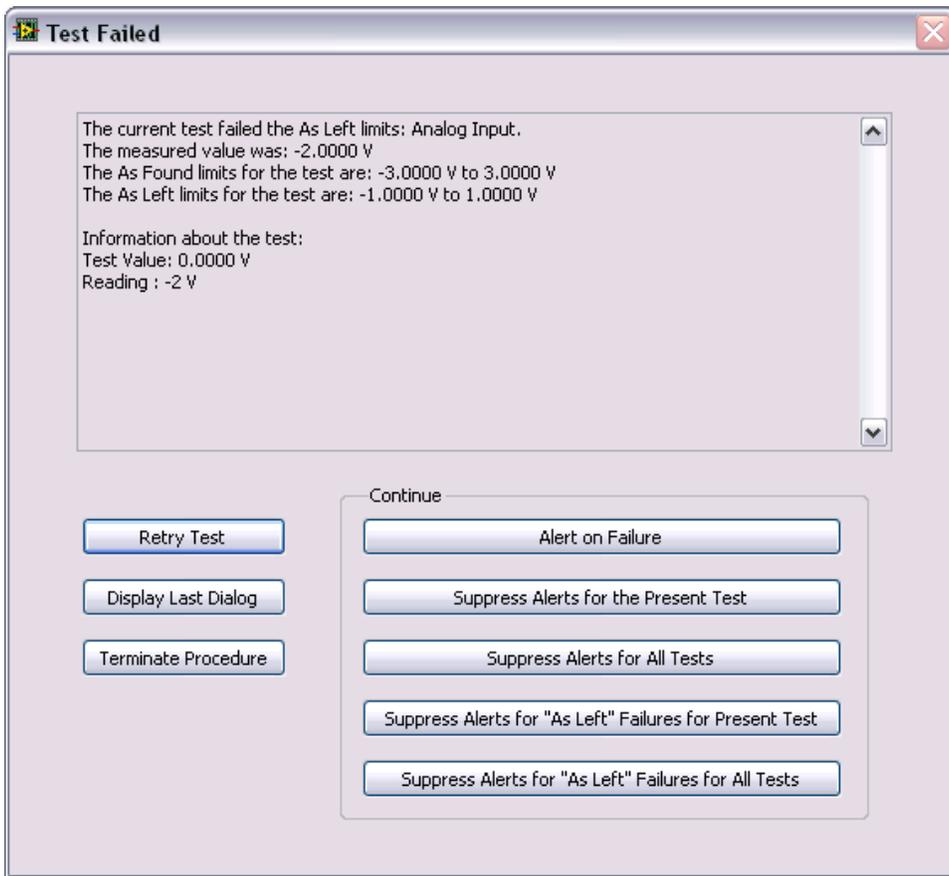

1. **Optional:** Retry the existing test point by selecting one of the available buttons.



Option	Description
Retry Test	Retries the current test point. Allows you to check your connections if you believe the failure to be a connection issue.
Display Last Dialog	Displays the last dialog box to aid in checking your connections.
Terminate Procedure	Terminates the procedure.

2. **Optional:** Continue to the next test point by selecting one of the available buttons in the Continue section. All of these options will accept the current failure and continue to the next test point.

Option	Description
Alert on Failure	Do not suppress future failures.
Suppress Alerts for the Present Test	Suppress all failure only for the current test. The next tests will display this dialog box for any failures.
Suppress Alerts for All Tests	This option will suppress all alerts.
Suppress Alerts for "As Left" Failures for Present Test	This option will suppress alerts only for as-left test limit failures for the present test, but will continue to display failures for As Found test limits. This option is not available during re-verify.
Suppress Alerts for "As Left" Failures for All Tests	This option will suppress only alerts for as-left test limit failures for all tests, but will continue to display failures for As Found test limits. This option is not available during re-verify.

The Execute Adjust Steps? dialog box appears after verification and detail whether or not there were test point failures.

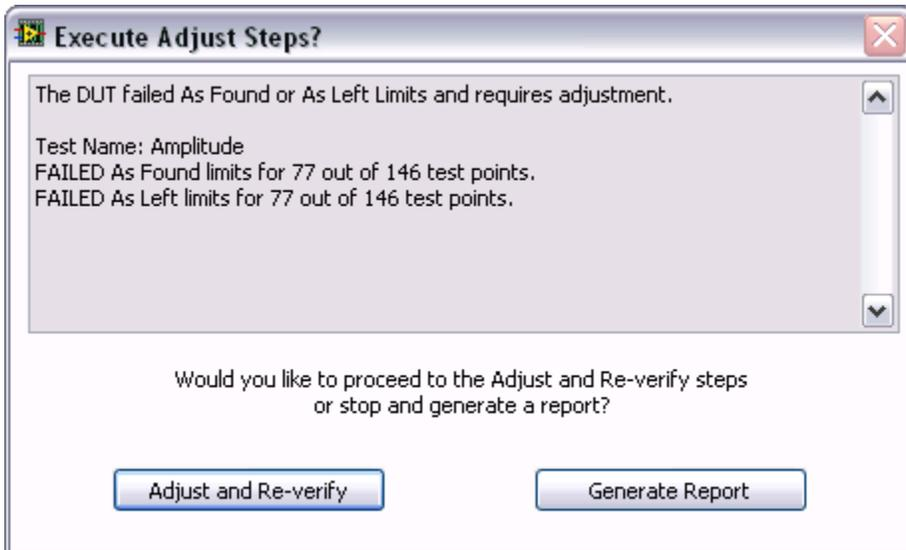

Select **Adjust and Re-verify** or **Generate Report** in the Execute Adjust Steps? dialog box.

**Related tasks:**

- [Selecting a DUT](#)

# Viewing a Calibration Report

You can view calibration reports in one of the following formats: text, HTML, PDF, or Microsoft Word.

1. Select **View»Calibration Reports** to display the Calibration Reports window, shown in the following figure.

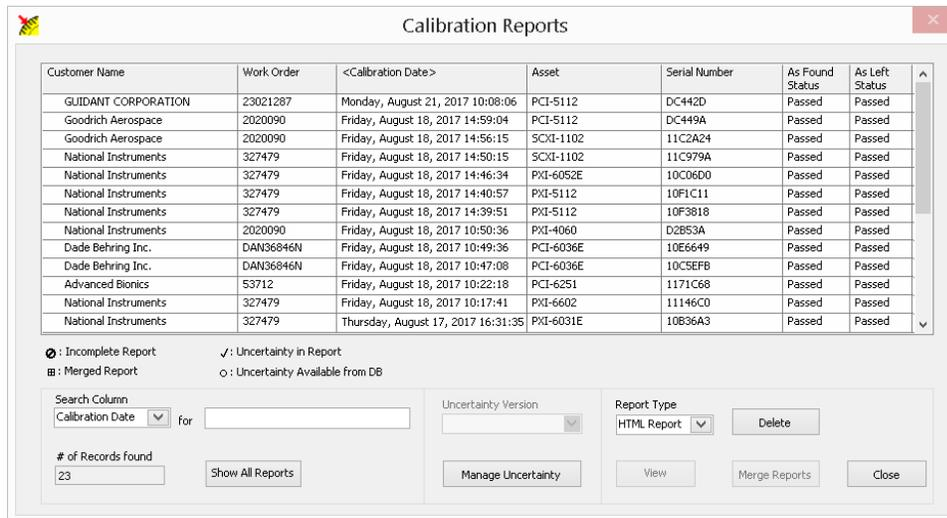

Customer Name	Work Order	<Calibration Date>	Asset	Serial Number	As Found Status	As Left Status
GUIDANT CORPORATION	23021287	Monday, August 21, 2017 10:08:06	PCI-5112	DC442D	Passed	Passed
Goodrich Aerospace	2020090	Friday, August 18, 2017 14:59:04	PCI-5112	DC449A	Passed	Passed
Goodrich Aerospace	2020090	Friday, August 18, 2017 14:56:15	SCXI-1102	11C2A24	Passed	Passed
National Instruments	327479	Friday, August 18, 2017 14:50:15	SCXI-1102	11C979A	Passed	Passed
National Instruments	327479	Friday, August 18, 2017 14:46:34	PXI-6052E	10C06D0	Passed	Passed
National Instruments	327479	Friday, August 18, 2017 14:40:57	PXI-5112	10F1C11	Passed	Passed
National Instruments	327479	Friday, August 18, 2017 14:39:51	PXI-5112	10F3818	Passed	Passed
National Instruments	2020090	Friday, August 18, 2017 10:50:36	PXI-4060	D2B53A	Passed	Passed
Dade Behring Inc.	DAN36846N	Friday, August 18, 2017 10:49:36	PCI-6036E	10E6649	Passed	Passed
Dade Behring Inc.	DAN36846N	Friday, August 18, 2017 10:47:08	PCI-6036E	10C5EFB	Passed	Passed
Advanced Bionics	53712	Friday, August 18, 2017 10:22:18	PCI-6251	1171C68	Passed	Passed
National Instruments	327479	Friday, August 18, 2017 10:17:41	PXI-6602	11146C0	Passed	Passed
National Instruments	327479	Thursday, August 17, 2017 16:31:35	PXI-6031E	10B36A3	Passed	Passed

Incomplete Report       Uncertainty in Report  
 Merged Report       Uncertainty Available from DB

Search Column: Calibration Date for [ ]      Uncertainty Version: [ ]      Report Type: HTML Report [Delete]

# of Records found: 23      [Show All Reports]      [Manage Uncertainty]      [View]      [Merge Reports]      [Close]

2. Highlight the report you want to view from the displayed list.
3. Use the **Report Type** field to select Text, PDF, HTML, or MS Word report type.
4. Click **View** to display the report or click **Delete** to remove the report from the database.
5. Click **Close** to close the Calibration Reports window and return to the main Calibration Executive user interface.



**Tip** The brackets around a column header indicate that the reports are sorted on this field. To sort on a different field, click on another column header.

## Calibration Reports

Calibration reports are stored in a central database. Calibration Executive retrieves the data from this database and displays the report in the format you have selected (text,

HTML, PDF, Microsoft Word, or Microsoft Excel). Each report includes the customer name and address, the purchase order number, calibration date, and DUT type (model) for the calibrated device, as well as similar information about the calibration standards used.

It is recommended that you use a 64-bit version of Microsoft Excel to generate calibration reports in Excel format.

Calibration Executive requires a 64-bit Java Runtime Environment (JRE) to generate reports in RTF (Microsoft Word) and PDF formats. The most recent version of the JRE is available at <https://java.com>. You must use a 64-bit browser to access the 64-bit download.



**Note** Refer to the Calibration Executive Readme for details about supported versions of the JRE. Note that some uses of Java may require a separate license.

## Reading the Calibration Report

The following terms are common to all of the calibration report tables.

- **Low Limit** is the lower limit of the reading allowable to meet specifications.
- **High Limit** is the upper limit allowable to meet specifications.
- **Reading** is the actual reading taken during the calibration procedure. For an ideal calibration, the reading value always lies between the upper and lower limits. If the reading is outside this range, the calibration fails.
- **As Found Status** details the response of the DUT prior to any adjustment, or as received at the calibration lab. Therefore, if the DUT is out of calibration, the as-found tests can fail.
- **As Left Status** represents the DUT performance after calibration, or as the DUT left the calibration lab. The DUT should pass the as-left tests.



**Note** The calibration report includes an error message if an error or a termination occurred that may have invalidated the calibration data.

**Related information:**

- [java.com](http://java.com)

## Calibration Reports Database

The calibration reports database, a Microsoft Access database, contains all of the results for each calibration.

By default, the database is named `Calibration Reports.mdb` and is stored in the Databases folder of Calibration Executive. If you installed Calibration Executive in the default location, this database is located in `C:\Program Files\National Instruments\Calibration Executive\DataBases`. The calibration reports database responds to standard structured query language (SQL) commands. Therefore, you can write your own report-handling routine to retrieve data from the database. You could write such a routine in LabVIEW, C, visual Basic, or any other language that supports SQL communication. The calibration reports database consists of the following seven tables:

- ASSET contains all of the information about the calibrated DUT.
- CALIBRATION\_DATA contains all the data acquired during the calibration, as well as the uncertainty data, if applicable.
- CUSTOMER contains all of the customer information associated with the DUT.
- ENGINE contains information about the operator and the calibration date.
- ENVIRONMENT contains information about the environmental conditions during the calibration.
- STANDARD contains information about the standards, such as calibrators and DMMs, that were used during the calibration.
- REPORT keeps track of all of the relationships between the six other tables.

The REPORT table contains a search value for each of the other tables. The search value is a unique number that represents all of the data associated with a specific calibration report—all the customer information, calibration condition information, and so on. To locate data associated with a given calibration, you must first find the search value for that data in the REPORT table. When you know the search value number for a specific report, you can search for a match to that number in the other search value fields of the table.

## Example: Using the Calibration Reports Database

Suppose you want to find out all of the calibration-related information—the calibration conditions, DUT specifics, calibration data, and so on—about the devices you have calibrated for a customer. To find that information, start by opening the CUSTOMER table and locating the name of your client. In the same row that the customer name appears, there is a numeric search value. With that search value, you can open the REPORT table and use that value to search the other tables for that customer's asset information, calibration data, and so on. You could also use that search value to write your own asset-handling routine.

## Saving a Calibration Reports Database Backup

This feature allows you to save a secondary copy of the current calibration reports database.

1. Select **Configure » Report Database Backup Copy**.
2. Click the folder icon to the right of the Path to Report Database Backup field to browse for the directory in which to store your calibration reports database backup.



**Note** Do not select the same directory where the original report database is saved.

3. Highlight the name of the directory.
4. Click **Open**.
5. Select the desired Calibration Executive version from the Select Version pull-down menu.



**Note** If you select Calibration Executive 3.2 or prior, the report files do not support the Driver Information section. So this information will not be in the source report database.

6. Click **Save As**.

## Merge Reports

1. Select **View » Calibration Reports** to display the Calibration Reports window.
2. Highlight the two reports you want to merge. If the two reports appear to be compatible, the **Merge Report** button enables as shown in the following figure.



**Note** The **Merge Report** button enabling is only a pre-checking function and does not mean that two reports can be merged.

Customer Name	Work Order	<Calibration Date>	Asset	Serial Number	As Found Status	As Left Status
National Instruments		Wednesday, October 14, 2009 16:29	PXI-4110	13D887D	Passed	Passed
National Instruments		Wednesday, October 14, 2009 14:39	PXI-4110	13D887D	Passed	Passed
National Instruments		Wednesday, October 14, 2009 13:05	cRIO-9263 revision E	13E91EF	Passed	Passed
National Instruments		Wednesday, October 14, 2009 13:00	cRIO-9263 revision E	13E91EF	Passed	Passed
National Instruments		Wednesday, October 14, 2009 12:05	PXI-6733	13C34DB	Passed	Passed
National Instruments		Wednesday, October 14, 2009 10:23	PCMIA-4050	143D140	Passed	Passed
National Instruments		Tuesday, October 13, 2009 15:16:43	PXI-4060	D56506	Passed	Passed
National Instruments		Friday, October 09, 2009 15:45:36	PXI-4070	12	Passed	Passed
National Instruments		Friday, October 09, 2009 15:23:30	PXI-4070	12	Passed	Passed
National Instruments		Thursday, October 08, 2009 12:43:11	SCXI-1121	D6CB23	Failed	Passed
National Instruments		Thursday, October 08, 2009 11:28:31	SCXI-1121	D6CB23	Passed	Passed
National Instruments		Thursday, October 08, 2009 9:50:58	SCXI-1100	D1DDDA	Passed	Passed
National Instruments		Wednesday, October 07, 2009 15:28	SCXI-1125	140C189	Passed	Passed

Search Column: Customer Name for [ ] # of Records found: 0

Report Type: HTML Report [v]

Buttons: Show All Reports, View, Merge Reports, Delete, Close

3. Select the report format using the **Report Type** pull-down menu.
4. Click **Merge Reports** to merge the two highlighted reports.
5. Edit the DUT notes if you enabled **Allow Editing of the DUT notes when reports are merged** on the Configuring Report Options window.
6. If the two reports are compatible, the merged report appears at the top of the report list, as shown in the following figure. If the reports are not compatible an error appears.

Customer Name	Work Order	<Calibration Date>	Asset	Serial Number	As Found Status	As Left Status
National Instruments		As Found Date: Wednesday, October 14, 2009 16:29	PXI-4110	13D887D	Passed	Passed
National Instruments		Wednesday, October 14, 2009 16:29	PXI-4110	13D887D	Passed	Passed
National Instruments		Wednesday, October 14, 2009 14:39	PXI-4110	13D887D	Passed	Passed
National Instruments		Wednesday, October 14, 2009 13:05	cRIO-9263 revision E	13E91EF	Passed	Passed
National Instruments		Wednesday, October 14, 2009 13:00	cRIO-9263 revision E	13E91EF	Passed	Passed
National Instruments		Wednesday, October 14, 2009 12:05	PXI-6733	13C34DB	Passed	Passed
National Instruments		Wednesday, October 14, 2009 10:23	PCMCI4-4050	143D140	Passed	Passed
National Instruments		Tuesday, October 13, 2009 15:16:43	PXI-4060	D6606	Passed	Passed
National Instruments		Friday, October 09, 2009 15:45:36	PXI-4070	12	Passed	Passed
National Instruments		Friday, October 09, 2009 15:23:30	PXI-4070	12	Passed	Passed
National Instruments		Thursday, October 08, 2009 12:43:11	SCXI-1121	D6CB23	Failed	Passed
National Instruments		Thursday, October 08, 2009 11:28:31	SCXI-1121	D6CB23	Passed	Passed
National Instruments		Thursday, October 08, 2009 9:50:58	SCXI-1100	D1DDDA	Passed	Passed

Search Column: Customer Name for [ ] # of Records found: 0

Report Type: HTML Report [v] [View] [Merge Reports] [Delete] [Close]

## Related concepts:

- [Configuring Report Options](#)

## Edit Report Attributes

Calibration Executive allows you to edit the following report attributes:

- DUT Notes
- Recommended Calibration Due Dates

### Edit DUT Notes

1. Select **View » Calibration Reports** to display the Calibration Reports window.
2. Select a calibration report from the list.
3. Click the **Edit** menu and select **DUT Notes**.



**Note** Edit menu options are disabled if more than one report is selected.

4. In the Edit DUT Notes dialog, modify the DUT notes as needed, and click **OK**.



**Note** Content in the **DUT Notes** text box must not exceed 255 characters.



**Notice** If you overwrite existing content in the **DUT Notes** field and click **OK**, the content will be lost. Be sure to review any current note before you modify



or delete it, as it may include important information about the procedure.

## Edit Recommended Calibration Due Dates

1. Select **View » Calibration Reports** to display the Calibration Reports window.
2. Select a calibration report from the list.
3. Click the **Edit** menu and select **Recommended Calibration Due Date**.



**Note** Edit menu options are disabled if more than one report is selected.

4. In the Edit Cal Due Date dialog box, enter a new date in the **New Recommended Calibration Due Date** field or click the calendar icon to select a new date and time.
5. Click **OK** when the correct date is set in the Edit Cal Due Date dialog box.



**Note** The Recommended Calibration Due Date is displayed only on certificates generated from a report configuration in which this feature is enabled. For more information, see **Show the Recommended Calibration Due Date** in **Custom Report Configurator**.



**Notice** When you click **OK** in the Edit Cal Due Date dialog box, the previous Recommended Calibration Due Date is permanently overwritten and therefore lost. Be sure to review the date before modify the **New Recommended Calibration Due Date** field.

### Related concepts:

- [Custom Report Configurator](#)

## Custom Report Configurator

Calibration Executive provides Custom Report Configurator tools that enable you to create custom report types for calibration certificates in PDF format, in addition to the default calibration report types.



**Note** Java SE Runtime Environment and a PDF reader application (Adobe

Acrobat Reader is recommended) must be installed on your system to generate custom reports.

To display the Custom Report Configurator dialog:

1. Select **View » Calibration Reports** to display the Calibration Reports window.

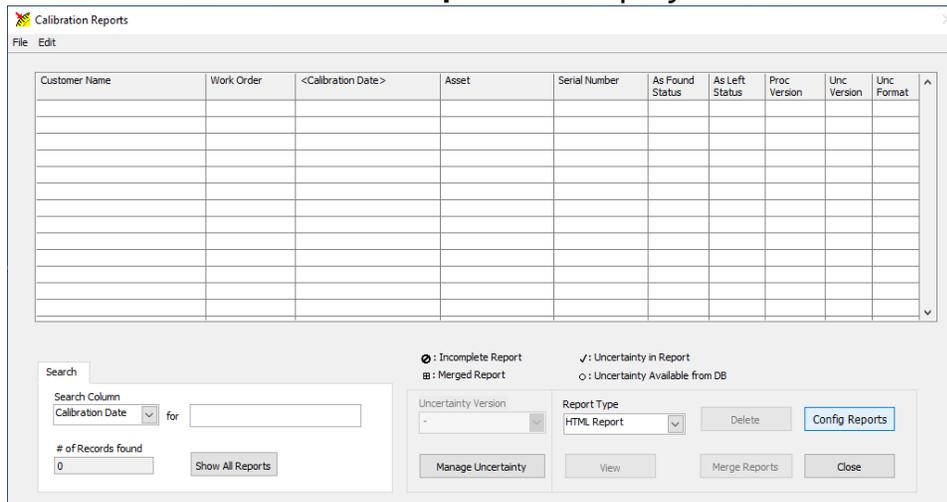

2. In the lower right corner of the Calibration Reports window, click **Config Reports**.

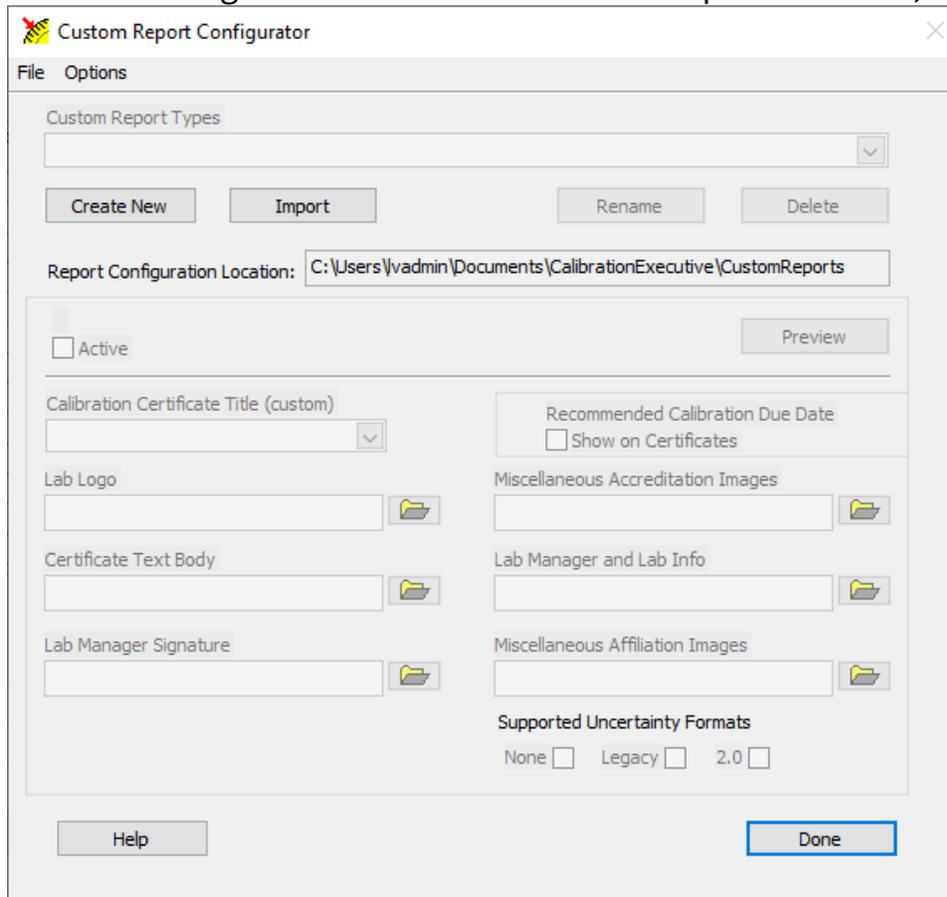



**Note** The Custom Report Configurator is only available when you run Calibration Executive in administrator mode. Refer to ***Frequently Asked Questions*** for more information.

From the Custom Report Configurator window, you can do the following.

## Create a New Report Configuration

To create a new report configuration:

1. In the Custom Report Configurator window, click **Create New**.
2. In the Generate New Report Configuration dialog, provide a name for the new report configuration and click **Create**. The report configuration name must meet the following criteria:
  - Cannot be longer than 60 characters.
  - Characters \, /, :, \*, ?, ", <, >, and | are not allowed.
  - Cannot end with a period (.).
  - Cannot be an empty string.
3. At the confirmation message, click **OK**.

## Set Report Configurations to Active/Inactive

New and imported report configurations are automatically set to **Active**, making the configurations available in the **Report Type** list on the Calibration Reports window. To keep a report configuration but remove it from the **Report Type** list in Calibration Reports, select the configuration in the **Custom Report Types** list, and deselect the **Active** checkbox.

## Select a Calibration Certificate Title

When you create or import a report configuration, you can select one of the following certificate titles, or specify your own title:

- Traceable Calibration Certificate
- Compliant Calibration Certificate
- Accredited Calibration Certificate



**Note** The Custom Report Configurator does not retain custom titles that you manually enter in the **Calibration Certificate Title** field as selectable options.

## Show the Recommended Calibration Due Date

To show the recommended calibration due date on a custom report configuration, select the **Show on Certificates** option in the **Recommended Calibration Due Date** section. For more information about specifying the calibration due date, refer to ***Edit Report Attributes***.

Related concepts:

- [Edit Report Attributes](#)

## Import an Existing Report Configuration

Imported configuration(s) are copied into the Report Configuration Location folder and are set to **Active**.

1. In the Custom Report Configurator window, click **Import**.
2. Browse to the folder that contains the report configuration you want to import.



**Note** To import multiple report configurations, select the folder that contains all of the report configurations that you want to import into the Custom Report Configurator.

3. Select the folder, and click **Select Folder**.
4. At the confirmation message, select **OK**.



**Note** Refer to ***Frequently Asked Questions*** for more information.

Related concepts:

- [Frequently Asked Questions](#)

## Rename or Delete Report Configurations

### Rename a Report Configuration

To rename a report configuration:

1. Select the report you want to rename in the **Custom Report Types** field.
2. Click **Rename**. The Rename Report Configuration dialog box opens.
3. Enter a new name in the field, and click **Rename**.

The new name cannot be the same as the previous name, and it is subject to the same criteria as when you created the report configuration.

### Delete a Report Configuration

To delete a report configuration:

1. Select the report configuration you want to delete in the **Custom Report Types** list.
2. Click **Delete**.
3. At the confirmation message, click **Yes** to delete the report configuration.



**Note** Deleting a report configuration removes the configuration from the Custom Report Configurator, but it does not delete the files. A deleted report configuration can be imported back into the Custom Report Configurator.

## Customize Report Configuration Design

You can customize the following elements of a report configuration by modifying the corresponding images or text files.

- Lab Logo (LogoImage.jpg)
- Miscellaneous Accreditation Images (TopRightImage.jpg)
- Certificate Text Body (BodyText.txt)
- Lab Manager and Lab Info (LabInfo.txt)
- Lab Manager Signature (Labsign.jpg)
- Miscellaneous Affiliation Images (BottomRightImage.jpg)

## Configure Uncertainty and Guard Band Options

### Select Supported Uncertainty Formats

Select one or more of the following **Supported Uncertainty Formats** options to specify which types of uncertainties are enabled for the selected custom report:

- **None:** Custom report supports formats that do not include any uncertainty or guard banding details.
- **Legacy:** Custom report supports uncertainty format used prior to Calibration Executive 6.0, which does not include any guard banding details
- **2.0:** Custom report supports uncertainty format used in Calibration Executive 6.0 and later, which includes uncertainty and guard banding details.

By default, a custom report supports all uncertainty formats. Uncertainty format options can be useful when you configure the display options for different types of reports in the Calibration Reports window.

To determine the uncertainty format used with each report, look for the value in the **Unc Format** column in the Calibration Reports window.

### Configure Uncertainty and Guard Band Display Options

When you select a custom report that was generated with a supported uncertainty format, the **Reading Display Options**, **Uncertainty Display Options**, and **Guardband Display Options** tabs appear at the lower left corner of the Calibration Reports window.

Uncertainty and Guard band settings are only available with Custom Reports, and the settings are cached separately for each custom report type. These options can be modified only when you are logged into Calibration Executive as an administrator.

- **Reading Display Options**—Reading display options enable you to toggle whether the as-found and as-left verify limits are displayed on the custom report. Leave the limits selected to display them on the report; deselect the limits to hide them. Reading display options are supported for all uncertainty formats.
- **Uncertainty Display Options**—Uncertainty display options enable you to toggle whether uncertainty values and uncertainty notes for as-found and as-left appear

in the custom report. Leave the options selected to display them on the report, deselect the options to hide them. Uncertainty display options are supported for all uncertainty formats.

- **Guard Band Display Options**—Guard band display options are only supported for 2.0 format uncertainties. Guard band display options include the following:
  - **Guardband:** Displays the guard band value.
  - **Accept Limits:** Displays the guard banded accept limits.
  - **TUR:** Displays the calculated test uncertainty ratio (TUR), formatted as TUR:1 in the report.
  - **Conditional P/F?:** Displays the passed/failed conditional character for each test point and for the overall results when a reading is determined to be either a conditional pass or a conditional fail.
  - **Guardband Notes:** Displays the description for the guard band methods used in the report, which appears in the report header. If displayed, this also includes the related callout for each method next to the passed/failed result of each test point that was guard banded.
  - **Max TUR:** A value of 0 indicates that all TURs are displayed. Otherwise, any TURs greater than the value specified in this field are hidden.
  - **Hide Zero Guardband:** When selected, if a guard band calculation results in a value of 0.0, the guard band is displayed as "-" in the report, and the related guard band method callout is not displayed next to the Passed/Failed result.

## Additional Options

### Preview a Report Configuration

To preview a report configuration, select the report in the **Custom Report Types** list, and click **Preview**. A temporary PDF file is generated, displaying the selected report configuration.

### Configure Page Size

You can specify the page size for your custom reports. Available page sizes are `Letter` (8.5 in. x 11 in.) and `A4` (210 mm x 297 mm). The default page size is `Letter`.

To configure the page size for your custom reports:

1. Press **Ctrl + P** or click the **Options** menu, and select **Set Page Size** to open the

Configure Page Size dialog.

2. Select one of the options, and then click **OK**.

## Change the Location of the Report Configuration

By default, the report configuration location is

```
C:\Users\<<username>\Documents\CalibrationExecutive\  
CustomReports.
```

To change the location of the report configuration files:

1. Press Ctrl + L or click the **Options** menu and select **Change Report Configuration Location**.
2. Browse to the location where you want to save report configurations, and then select **Select Folder**.

## Frequently Asked Questions

**Q:** What happens if I try to edit a report configuration in a location that is currently opened by another user on a shared network?

**A:** When you click **Config Reports**, a Locked Report Configuration Location message is displayed. In this dialog box, you can select one of the following actions:

- **Cancel** — Close the Custom Report Configurator to avoid corruption of configuration files. The **Report Configuration Location** remains the configured path, and you can use the available report formats from the Calibration Reports window.
- **Change Location** — Select a different Report Configuration Location to edit.
- **Force Unlock** — Unlock the current Report Configuration Location. This permits two or more users to edit the configurations at the same time; however, files may become corrupted. Choose this option only if you are sure that no one else is editing configurations at this location.

**Q:** What happens if I try to import a configuration folder that has the same name as a configuration folder that already exists in my specified location?

**A:** During import, a pop-up informs you that there is a conflict with the imported



configuration. Do one of the following:

- Click **Yes** to overwrite the existing configuration with the configuration you are importing.
- Click **No** to import the new configuration with `_Import#` appended to the end of the configuration name. The number at the end indicates the instance of the imported configuration (`_Import1`, `_Import2`, and so on). After import, you can rename the configuration (select the configuration and click **Rename**).

**Q:** Why is there a **Migrate Reports** button instead of the **Config Reports** button?

**A:** Calibration Executive 6.0 uses a new custom reports stylesheet which is required to utilize guard banding features for 2.0 uncertainty formats.

Calibration Executive attempts to migrate stylesheets from your existing custom reports automatically, but if any of the stylesheets have been modified manually, they cannot be migrated without losing information. You may continue to use your reports without migrating, but you will be unable to use any of the new custom report functionality.

When you click **Migrate**, Calibration Executive prompts you to overwrite your modified stylesheets. If you continue, you will lose these modifications and will need to recreate any customizations you wish to retain. Calibration Executive does save a backup of your stylesheet, which you can use for reference.

## Understanding the CAL-5501 Calibration Certificate

The CAL-5501 calibration certificate provides a summary of as-found and as-left verification results in the **Characterization Summary** table. Additionally, the calibration certificate includes links to data archive (`.zip`) folders that contain S-parameter measurements for each calibration standard. Click the links in the **Calibration Files** section of the calibration certificate to download the archive folders.

New devices have only an **As Left** archive folder while devices returned for calibration have **As Found** and **As Left** archive folders.

The **As Left** archive folder contains files with S-parameter measurements, measurement uncertainties, and how the measurements compare to family

performance. Calibration Executive uses the vector difference between the S-parameter measurements and family performance to determine if the As Left verification results passed or failed.

The **As Found** archive folder contains files with S-parameter measurements and how the measurements compare to the previous calibration. Calibration Executive uses the measurement drift since the previous calibration to determine if the as-found verification results passed or failed. Calibration Executive evaluates drift using normalized error,  $E_n$ , as specified in ***EURAMET Calibration Guide No. 12 Version 3.0 (03/2018)***.

## Measurement Uncertainty

Measurement uncertainty is an estimate of the range of values about the measured value within which the accepted value is believed to lie. A total uncertainty value represents the combination of a measure of the random error and estimated bounds of the systematic error and considers all factors that contribute to the measurement uncertainty. For detailed information about measurement uncertainty, refer to ***ANSI/NCSL Z540-2-1997, U.S. Guide to the Expression of Uncertainty in Measurement***.

Calibration Executive provides tools that enable a laboratory to manage the uncertainties for each test point of a procedure based on their lab capabilities, and to capture uncertainties in reports.

Uncertainties can also be used to calculate guard banding that can be applied to each test point at runtime and in the report. Refer to Measurement Guard Banding for more details on guard banding.

### Displaying Measurement Uncertainty in Calibration Executive Reports

In Calibration Executive, use the Uncertainty Management utility to display uncertainties associated with procedures and to include uncertainties and guard banding in reports. Users with Administrator privileges can access this utility from the Calibration Reports window.

Complete the following steps to launch the Uncertainty Management utility.

## 1. Select View » Calibration Reports.

The screenshot shows the 'Calibration Reports' window with a table of calibration data. The table has columns for Customer Name, Work Order, Calibration Date, Asset, Serial Number, As Found Status, As Left Status, Proc Version, Unc Version, and Unc Format. Below the table are search and filter controls, including a search column dropdown, a search text box, a record count, and buttons for 'Show All Reports', 'Manage Uncertainty', 'View', 'Merge Reports', and 'Close'.

Customer Name	Work Order	<Calibration Date>	Asset	Serial Number	As Found Status	As Left Status	Proc Version	Unc Version	Unc Format
Mock Customer	WO12345	Wednesday, May 20, 2020 11	PXIe-5673	321	Passed	Passed	4.2.0.0	0.2	Legacy
Mock Customer	WO12345	As Found Date: Wednesday,	NI 9212	321	Passed#	Passed	4.6.2.0 / 4.0	0 / 0	2
Mock Customer	WO12345	Wednesday, May 13, 2020 12	NI 9212	321	Passed	Passed	4.6.2.0	0	2
Mock Customer	WO12345	Wednesday, May 13, 2020 12	NI 9212	321	Passed#	Passed#	4.6.2.0	0	2
Mock Customer	WO12345	Wednesday, May 13, 2020 12	NI 9212	321	Failed#	Failed#	4.6.2.0	FAKE2	2
Mock Customer	WO12345	Wednesday, May 13, 2020 10	NI 9201	321	Failed#	Failed#	3.6.0.0	FAKE2	2
Mock Customer	WO12345	Wednesday, May 13, 2020 9:	cRIO-9215	321	Failed#	Failed#	3.6.0.0	FAKE2	2
Mock Customer	WO12345	As Found Date: Tuesday, Ma	PXI-6704	321	Passed#	Passed#	3.6.4.0 / 3.0	FAKE2 /	2
Mock Customer	WO12345	Tuesday, May 12, 2020 3:11:4	cRIO-9201 with DSUB	321	Passed	Passed	3.6.0.0	0	Legacy
Mock Customer	WO12345	Tuesday, May 12, 2020 11:52:	PXI-6704	321	Passed#	Passed#	3.6.4.0	FAKE2	2
Mock Customer	WO12345	Tuesday, May 12, 2020 11:51:	PXI-6704	321	Passed#	Passed#	3.6.4.0	FAKE2	2
Mock Customer	WO12345	Tuesday, May 12, 2020 11:51:	PXI-6704	321	Passed	Passed	3.6.4.0	None	
Mock Customer	WO12345	Tuesday, May 12, 2020 11:50:	PXI-6704	321	Failed#	Failed#	3.6.4.0	FAKE2	2

## 2. On the Calibration Reports window, click Manage Uncertainty.

The screenshot shows the 'Uncertainty Export / Import' window with a table of uncertainty templates. The table has columns for Device Name, Procedure Version, Last Updated, Version, Format, and Notes. Below the table are search and filter controls, including a search text box, a legend for report availability, and buttons for 'HELP' and 'DONE'.

Device Name	Procedure Version	Last Updated	Version	Format	Notes
PXIe-4330 (legacy fixtur	5.0.1.0	-	-	-	-
PXIe-4331	5.0.1.0	-	-	-	-
PXIe-4331 (legacy fixtur	5.0.1.0	-	-	-	-
cRIO-9201 with DSUB	3.6.0.0	5/21/2020 1:43 P 0	0	2.0	Uncertainty Notes
NI 9201	3.6.0.0	5/1/2019 5:59 PM 0	0	Legacy	-
NI 9201 with DSUB	3.6.0.0	5/1/2019 5:59 PM 0	0	Legacy	-
NI 9203_test (NI 9203)	3.6.1.0 (3.6.0.0)	5/1/2019 5:59 PM 0	0	Legacy	-
NI 9205	3.6.0.0	5/1/2019 5:59 PM 0	0	Legacy	-
NI 9205 with DSUB	3.6.0.0	5/1/2019 5:59 PM 0	0	Legacy	-
NI 9206	3.6.0.0	5/1/2019 5:59 PM 0	0	Legacy	-
NI 9211	4.0.0.0	5/1/2019 5:59 PM 0	0	Legacy	-
NI 9212	4.0.0.0	5/1/2019 5:59 PM 0	0	Legacy	-

Use the Uncertainty Export/Import window to export a template that you can use to edit uncertainties and guard bands for each test point in the procedure. Import the edited values to an uncertainties database, which appends the uncertainties to future runs of the procedure.

## Exporting and Editing Uncertainty Templates

Export an uncertainty template from an existing report for a procedure that has completed without terminating. You cannot export an uncertainty template if a procedure does not have a completed run with a report.

There are two types of uncertainty templates.

- **Legacy:** Templates exported prior to Calibration Executive v. 6.0, or for any procedures without reports generated in Calibration Executive 6.0 or later. Legacy (1.0) templates do not include any guard banding details.
- **2.0:** Templates exported for procedures with reports generated in Calibration Executive v. 6.0 or later. The 2.0 templates include all uncertainty and guard band fields.

Complete the following steps to export an uncertainty template.

1. In the Calibration Reports window, click **Manage Uncertainty**.
2. From the **Uncertainty List** in the Uncertainty Export/Import window, select the device you want to use for export.
3. Select **Operate** » **Export to File** or right-click the device name and select **Export Template**.
4. In the Select Export Folder dialog box, select the location to save the exported file, and use the **File Type to Export** drop-down to specify the file type. Calibration Executive supports the following template formats:
  - `.xlsx` (Single Workbook) is the recommended format. This format (Office Open XML Spreadsheet) is compatible with many spreadsheet editors, such as Microsoft Excel 2007 SP3 or later, Apache OpenOffice, and Google Sheets.



**Note** For procedures with more than 1000 test points, uncertainties are exported to a CSV file; refer to the XLSX file for instructions to copy the data manually into the XLSX file. The Open XML parser that Calibration Executive uses is limited to procedures with fewer than 1000 test points.

- `.csv` (comma-delimited) format generates a single CSV file with all test points listed as comma-separated values, which can then be edited with a variety of text and spreadsheet editors.
- `.txt` (tab-delimited) format generates a single TXT file with all test points listed as tab-separated values, which can then be edited with a variety of text and spreadsheet editors.
- `.xlsx` (Legacy Workbook / Device) is a deprecated format that was used prior to Calibration Executive version 6.0. This file format is not supported for exporting 2.0 version uncertainty templates.

The exported files include instructions for how to add uncertainties.

5. Click **Done** to return to the Calibration Reports window.

Complete the following steps to edit an uncertainty template.

1. Locate the folder where you saved the uncertainty template. The default path begins with `C:\Program Files\National Instruments\Calibration Executive\Uncertainty\`.
2. Open the template, and edit the appropriate fields to add uncertainties. Refer to and for information about template fields that can be edited.
3. Save the updated uncertainty template.

## Legacy and 2.0 Fields

The following uncertainty data fields from the Legacy and 2.0 templates are editable:

- **Uncertainty Version:** This field is populated with 1.0 by default for new uncertainty exports. You can change this to any string up to 40 characters in length. Use this field for traceability and to store multiple unique uncertainties in your database. This field is displayed in the Uncertainty Version section of your report.
- **Uncertainty (dbl):** Enter a numeric value that represents the uncertainty to display on your report. Enter 0 or leave the field blank if you want only to display the notes field. The uncertainty value is displayed in scientific format using two digits of precision. The digits of precision for the reading and limits fields will be scaled to match the least significant digit of the uncertainty for each new run of the procedure.

For example, if the uncertainty value for a test point is  $0.0012 \text{ V}$ , the uncertainty value will be displayed on the report as  $1.2\text{E}-3 \text{ V}$ . The readings and limits will subsequently display with 4 digits of precision, for example,  $1.1234 \text{ V}$ .

- **Uncertainty Units:** If left blank, the units are assumed to be base International System of Units (SI). For example, if the limits units are mV, then these units will be populated as V when imported. If you manually enter units, and they are not entered as base units, then the uncertainty value and the units will be converted to base units on import. If the manual base SI units do not match the base SI units of the reading, then the digits of precision will not be scaled automatically, and the default from the procedure will be used.
- **As Found Uncertainty Notes:** Free text field; the notes are appended to the as-

found uncertainty value before being displayed on the report.

- **As Left Uncertainty Notes:** Free text field; the notes are appended to the as-left uncertainty value before being displayed on the report.

## 2.0-Only Fields

The following uncertainty data fields from the 2.0 templates are editable:

- **As Found/As Left Guardband Type:**
  - none
  - method 5
  - method 6
  - method 6 linear
  - method 6 db
  - method 6 dbv
  - custom\_<name>
- **As Found/As Left Modifiers:** See Measurement Guard Banding for details about how Calibration Executive uses the values in this field. Use a semicolon (;) to separate multiple modifiers contained in this field. For example, `customval=1.23E-2;UL`.
  - `customval = <value>`, where <value> is a floating point numeric (e.g., 1.234) or an exponential (e.g., 1.23E-6)
  - UL (Only the upper limit is valid)
  - LL (Only the lower limit is valid)
  - `nominal = <value>` is a floating point numeric (e.g., 1.234) or an exponential (e.g., 1.23E-6)
    - **nominal=1.0E-1** — If you do not specify units, they are assumed to be equivalent to the limits unit without an SI prefix. That is, if the limits unit column contains mV, then the nominal value is assumed to be 1.0E-1 V and will be applied to the TUR formulas with this magnitude.
    - **nominal=1.0E-1 mV** — If you specify units as in this example, then you may also specify an SI prefix. This can make it easier to compare the nominal value to the limits or values with the same prefix. At runtime, the prefix is taken into account and the value is converted to match the magnitude of the limits unit.
- **CMC (dbl):** CMC defines the Scope of Accreditation. If this value is larger than the Uncertainty, it is logged as the uncertainty with the report. This value is not used in

guard band calculations. The values in this field should be reported in the same units as the uncertainty but without the prefix. For example, if the uncertainty is 1 mV and the CMC is 0.5 mV, convert to volts (V) and enter  $5E-4$  in the CMC field.



**Note** The maximum number of combined characters for **Uncertainty**, **Uncertainty Units**, and **Notes** is 50 characters. Uncertainty data is truncated upon import if it exceeds 50 characters. You must enter at least two characters; fewer than two characters will not be displayed and may affect the formatting of the report.

## Importing Uncertainties from a Template File

After you have edited the template file, import the values to the uncertainties database. Calibration Executive imports only the values in uncertainty data fields, but many of the other fields are used as reference and should not be modified. When you import uncertainties from an Open XML spreadsheet and use a formula to calculate your uncertainty, only the resulting value is imported into the database. Calibration Executive supports only formulas resulting in numeric or text values.

Complete the following steps to import uncertainties.

1. From the Calibration Reports window, click **Manage Uncertainty**.
2. In the Uncertainty Export/Import window, select **Operate » Import from File**, and browse to the location of the uncertainty template you want to import.
3. Select the template and click **OK**.
4. In the Uncertainty Export/Import window, click **Done**.

Once the uncertainties have been imported to the database, the template file is no longer needed, but could be useful later for tracking purposes.

## Updating Guard Band Notes

Use guard band notes to describe the guard band method in the calibration certificate. Calibration Executive adds the notes to the calibration certificate when you run the procedure. You can edit guard band note descriptions and report text for both built-in and custom guard band methods.

To view the **Guardband Notes** table, select **Operate » Edit Guardband Notes** from the menu bar on the Uncertainty Export/Import window.

To edit a **Description** or **Report Text** field, right-click the text and select **Edit Guardband Description** or **Edit Guardband Notes**.

To add a custom guard band, right-click a line of text and select **Insert New Custom Guardband**. After you enter the Tag Name, you can edit the description and the report text.

To delete a custom guard band, right-click the guard band and select **Delete Custom Guardband**. You cannot delete built-in guard band methods.

## Updating Uncertainty Version and Notes

Update uncertainty versions and uncertainty notes directly from the Uncertainty Export/Import window. Right-click the version or note you want to update, and then follow the instructions. These fields are also available in the exported template; you can modify the fields in the template before importing it.

## Multiple Uncertainties

Import multiple versions of uncertainties for each procedure so you can use different values under different circumstances. After importing the first version of uncertainties, you can import additional uncertainty versions by adding a unique version to the template worksheet each time you import the file. Calibration Executive adds the values to the database and the new version appears in the list of uncertainties on the Uncertainty Export/Import window.

## Adding Uncertainties to a Report

After you add the uncertainties for a procedure, use the Options and Environmental Information page in the setup wizard to select the version of uncertainties to display on the report. The **Uncertainty Version** selection box lists all active versions, along with an option to not report the uncertainty.



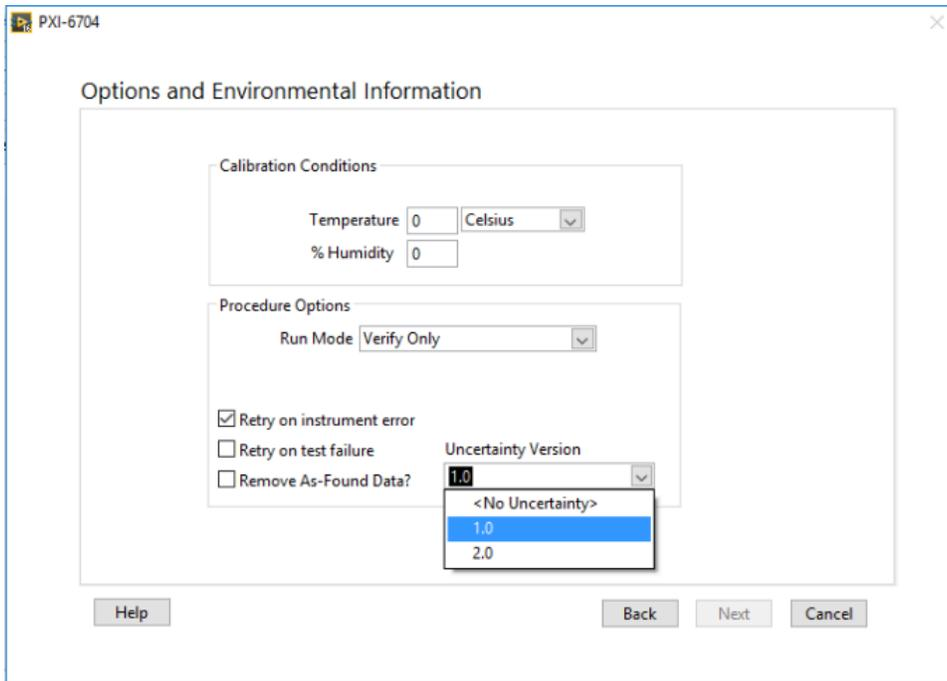

If your station does not require uncertainties, disable the Uncertainty Version control by toggling the global uncertainties option under **Configure » Report Options**.

## Modifying Uncertainties for a Procedure

If you need to modify the uncertainties for a procedure, change and re-import the previous template or create a new template that is pre-loaded with the current uncertainties. For Legacy uncertainties, you can create a new template only if a valid report exists on the station, similar to the requirement for creating the original template. You do not need a report to export 2.0 uncertainties. To export a 2.0 format uncertainty, select **Operate » Export to File**, or right-click the uncertainty and select **Export**.

## Deleting Uncertainties

To delete uncertainties, select **Operate » Delete Items**. Calibration Executive displays all uncertainties stored in the database. Select the uncertainties you want to delete and click **Delete**. Alternatively, you can right-click an uncertainty you want to delete and select **Delete Uncertainty from DB**.



**Notice** Calibration Executive does not create a backup of the deleted files.

## Updating Uncertainties on Existing Reports

NI recommends that you add uncertainties by selecting the appropriate uncertainty before running a procedure. However, you can generate a report with a different set of uncertainties from the Calibration Reports window.

In the Calibration Reports window, use the **Uncertainty Version** control to select which uncertainty version should be displayed on the report. The default is the version with which the report was originally generated.



**Notice** If you choose to display an uncertainty that is different from the original, beware of these potential issues:

- The digits of precision of the readings and limits will not be changed from the original report. This may result in an undesired discrepancy.
- You will not be able to display guard band information on your report because guard band details are determined at runtime and they will not be re-calculated.

## Importing Uncertainties for New Procedure Versions

When upgrading Calibration Executive, procedure versions may change if the procedure has been modified. If this happens, the uncertainties for the previous versions of the procedure will not be compatible with the new versions, and you will need to import a new version of the uncertainties. To do this, each new version of a procedure requires that you generate a new report first, to generate an accurate template.

If you need to add uncertainties for multiple versions of a procedure, then you must create and import a separate template for each version.

You can determine the procedure version of your stored uncertainty by viewing this information in the Uncertainty Management utility. To check the current procedure version, select the device from the **Device Types** control, and then select **Help » About Procedure**. The About Procedure dialog box displays the procedure name, version of the procedure, and a change list.

## Uncertainty Database Options

Use the Uncertainty Management Export/Import window to specify or change the location of the uncertainty database. You can set the location to a networked location that multiple systems can share.

Uncertainties developed on other systems can also be imported into the local system using menu options in the Uncertainty Management Export/Import window.

### Related concepts:

- [Measurement Guard Banding and TUR Support](#)
- [Custom Report Configurator](#)
- [Example: Calculating the Uncertainty for a Test Point](#)

## Example: Calculating the Uncertainty for a Test Point

The following example is the uncertainty calculation for the PCI-MIO-16XE-10 at the 9.98 V analog input Test Point, 20 V range, bipolar mode ( $\pm 10$  V), using a Fluke 5720A calibrator that was calibrated one year ago.

### Calibrator Uncertainty

The specification for the Fluke 5720A calibrator at 1 year, 95% confidence level ( $k = 1.96$  for normal distribution) is 3.5 ppm + 2.5  $\mu$ V.

$$3.5 \text{ ppm} \times 9.98 \text{ V} + 2.5 \text{ } \mu\text{V} = 37.43 \text{ } \mu\text{V}$$

$$\text{Standard Uncertainty} = \frac{37.43 \text{ } \mu\text{V}}{1.96} = 19.1 \text{ } \mu\text{V}$$

### Resolution of Device

$$\text{Resolution} = \frac{\text{Range}}{\text{Number of Levels of 16-bit ADC}}$$

$$\text{Resolution} = \frac{20\text{V}}{2^{16}}$$

$$\text{Resolution} = 305.175 \text{ } \mu\text{V}$$

$$\text{Standard Uncertainty} = \frac{1}{2} \left( \frac{\text{Resolution}}{\sqrt{3}} \right) = 88.1 \text{ } \mu\text{V}$$

## Noise and Other Type A Uncertainty

Standard deviation from 10,000 measurements was 207  $\mu\text{V}$ .

$$\text{Standard Uncertainty of Mean} = \frac{\text{Standard Deviation}}{\sqrt{N}}$$

$$\text{Standard Uncertainty of Mean} = \frac{207 \mu\text{V}}{\sqrt{10000}} = 2.07 \mu\text{V}$$

## Combined Standard Uncertainty

Use the square root of sum of squares method.

$$\text{Combined Standard Uncertainty} = \sqrt{19.1\mu\text{V}^2 + 88.1\mu\text{V}^2 + 2.07\mu\text{V}^2}$$

$$\text{Combined Standard Uncertainty} = 90.2\mu\text{V}(1\sigma \text{ normal distribution})$$

## Final Expanded Uncertainty

To convert into 95% confidence level, multiply the standard uncertainty by the coverage factor.

$$90.2 \mu\text{V} \times 1.96 = \pm 177 \mu\text{V}$$

$\pm 177 \mu\text{V}$  is the value printed on the calibration report.

## Measurement Guard Banding and TUR Support

The guard band value can be calculated at runtime using different methods, and then applied at runtime to the upper and lower limits to determine if a reading should be represented as Pass, Fail, or Conditional. The figures below illustrate how guard banding is applied to the limits to determine how the results of the reading should be represented.

### Statement of Conformity

When a statement of conformity to a specification is provided, NI uses decision rules and considers the level of risk to determine conformance with the agreed specification.

By default, the decision rule for test points is ILAC-G8:09/2019 section 4.2.1, Binary

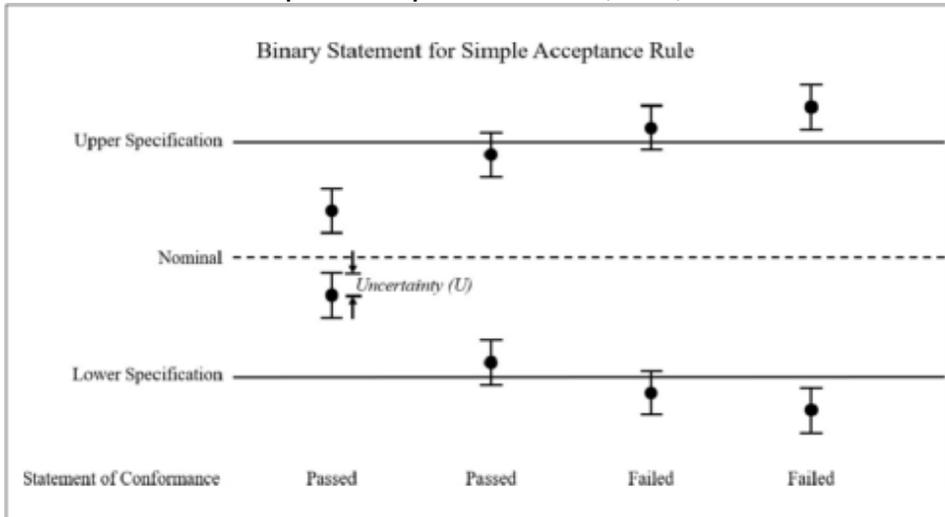
Statement for Simple Acceptance Rule ( $w=0$ ).

For test points with double-sided limits, a guard band is applied if the TUR is less than 4:1. For test points with a single-sided limit, a guard band is always applied. For test points where a guard band is applied (as noted in the status column), the decision rule is ILACG8:09/2019 4.2.3, Non-binary Statement with Guard Band.

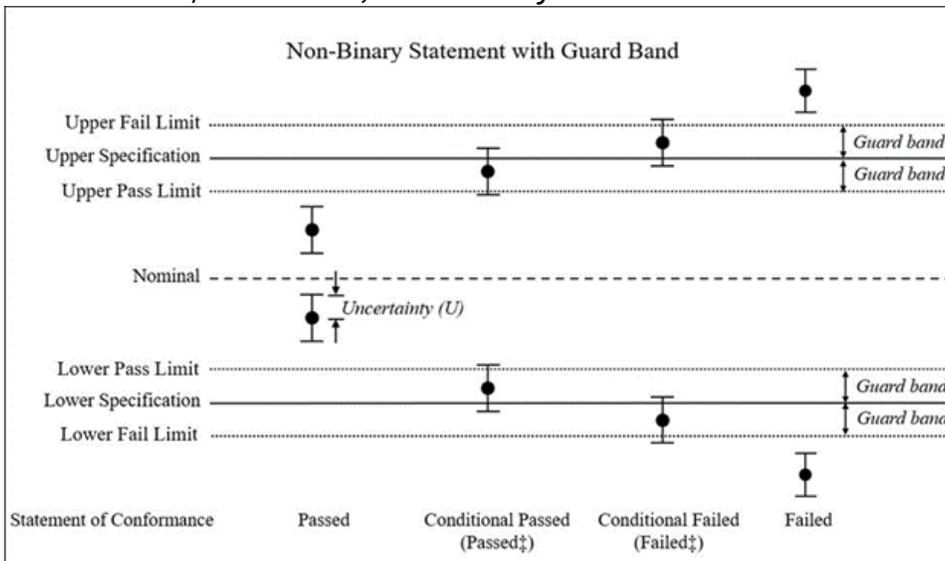

## Guard Band and TUR Calculations Supported by Calibration Executive

For all guard band methods, see the formulas below for the Acceptance Limits and Conditional Pass/Fail Limits calculations.

On the uncertainty worksheet, you can specify whether to apply guard band to only the upper or only the lower limit by adding the modifier "UL" or "LL" to the As-Found or As-Left Modifiers columns. By default, the guard band is applied to both upper and lower limits.

## Built-in Guard Band and TUR Calculations

ANSI/NCSL Z540.3-2006 is the American national standard for the calibration of measurement and test equipment. The ANSI/NCSL Z540.3 standard recommends six methods to calculate and apply guard band to ensure a probability of false accepts (PFA) of  $\leq 2\%$ . ANSI/NCSL Z540.3-2006 Method 5 and Method 6 described in the standard Appendix A are built into Calibration Executive.

In Calibration Executive, the lookup name `method5` uses a formula that complies with ANSI/NCSL Z540.3-2006 Method 5 to calculate guard bands. This method sets the guard band to be equal to the measurement uncertainty for each test point.

The `method6` lookup names in Calibration Executive apply to formulas that comply with Z540.3-2006 Method 6. For `method6`, calculations vary depending on the uncertainty units.

For test points that have valid upper and lower limits, and uncertainty values that are  $> 0$ , the Test Uncertainty Ratio (TUR) will be calculated automatically and will be available on custom reports when using the 2.0 uncertainty template. Use the "UL" and "LL" modifiers on the uncertainty worksheet to configure valid limits. The TUR calculation depends on the uncertainty units (Linear, dB, or dBv). The following table describes the Method 6 calculations and TUR calculations according to the uncertainty units.

**Table 5.** ANSI/NCSL Z540.3-2006 Method 6 and Test Uncertainty Ratio Formulas

Uncertainty Unit	Lookup Name	Formulas
dB	<code>method6_db</code>	Pass/Acceptance Limit Formulas: $A_{-} \left[ \text{dB} \right] = \text{Nom} \left[ \text{dB} \right] + 10 \times \log \left( 1 + \frac{A_{-} \%}{100} \right)$ $A_{+} \left[ \text{dB} \right] = \text{Nom} \left[ \text{dB} \right] + 10 \times \log \left( 1 + \frac{A_{+} \%}{100} \right)$ $A_{-} \% = \text{Spec}_{-} \% + U_{-} \% \times M$ $A_{+} \% = \text{Spec}_{+} \% + U_{+} \% \times M$

Uncertainty Unit	Lookup Name	Formulas
		<p>Fail Limit Formulas:</p> $F_- [\text{dB}] = \text{Nom} [\text{dB}] + 10 \times \log \left( 1 + \frac{\text{Spec}_- \% - U_- \% \times M}{100} \right)$ $F_+ [\text{dB}] = \text{Nom} [\text{dB}] + 10 \times \log \left( 1 + \frac{\text{Spec}_+ \% - U_+ \% \times M}{100} \right)$ $M = 1.04 - e^{(0.38 \ln(\text{TUR}) - 0.54)}$ $\text{Spec}_+ \% = \left( 10^{\left( \frac{ \text{UL}[\text{dB}] - \text{Nom}[\text{dB}] }{10} \right)} - 1 \right) \times 100$ $\text{Spec}_- \% = \left( 10^{\left( \frac{ \text{LL}[\text{dB}] - \text{Nom}[\text{dB}] }{10} \right)} - 1 \right) \times 100$ $\text{TUR} = \frac{\frac{ \text{UL}[\text{dB}] - \text{Nom}[\text{dB}] }{10} - \frac{ \text{LL}[\text{dB}] - \text{Nom}[\text{dB}] }{10}}{0.02 \times U \%}$ $U \% = \frac{\left( 10^{\left( \frac{U[\text{dB}]}{5} \right)} - 1 \right) \times 100}{\left( 10^{\left( \frac{U[\text{dB}]}{5} \right)} + 1 \right)}$
dBv	method6_dbv	<p>Pass/Acceptance Limit Formulas:</p> $A_- [\text{dBv}] = \text{Nom} [\text{dBv}] + 20 \times \log \left( 1 + \frac{A_- \%}{100} \right)$

Uncertainty Unit	Lookup Name	Formulas
		$A_+ [\text{dBv}] = \text{Nom} [\text{dBv}] + 20 \times \log \left( 1 + \frac{A_+ \%}{100} \right)$ $A_- \% = \text{Spec}_- \% + U_- \% \times M$ $A_+ \% = \text{Spec}_+ \% + U_+ \% \times M$ <p>Fail Limit Formulas:</p> $F_- [\text{dBv}] = \text{Nom} [\text{dBv}] + 20 \times \log \left( 1 + \frac{\text{Spec}_- \% - U_- \% \times M}{100} \right)$ $F_+ [\text{dBv}] = \text{Nom} [\text{dBv}] + 20 \times \log \left( 1 + \frac{\text{Spec}_+ \% - U_+ \% \times M}{100} \right)$ $M = 1.04 - e^{(0.38 \ln(\text{TUR}) - 0.54)}$ $\text{Spec}_+ \% = \left( 10^{\left( \frac{\text{UL} [\text{dBv}] - \text{Nom} [\text{dBv}]}{20} \right)} - 1 \right) \times 100$ $\text{Spec}_- \% = \left( 10^{\left( \frac{\text{LL} [\text{dBv}] - \text{Nom} [\text{dBv}]}{20} \right)} - 1 \right) \times 100$ $\text{TUR} = \frac{\frac{\text{UL} [\text{dBv}] - \text{Nom} [\text{dBv}]}{20} - \frac{\text{LL} [\text{dBv}] - \text{Nom} [\text{dBv}]}{20}}{0.02 \times U \%}$



Uncertainty Unit	Lookup Name	Formulas
		$U \% = \frac{\left( 10^{\left( \frac{U[\text{dBv}]}{10} \right) - 1} \times 100 \right)}{\left( 10^{\left( \frac{U[\text{dBv}]}{10} \right) + 1} \right)}$
Units other than dB and dBv	method6_linear	$\text{Guardband} = U \times \left( 1.04 - e^{(0.38 \ln(\text{TUR}) - 0.54)} \right)$ $\text{TUR} = \frac{UL - LL}{2 \times U}$ $A_- = LL + \text{Guardband}$ $A_+ = UL + \text{Guardband}$ $F_- = LL + \text{Guardband}$ $F_+ = UL + \text{Guardband}$
<p>A<sub>-</sub> = Lower Pass/Acceptance Limit</p> <p>A<sub>+</sub> = Upper Pass/Acceptance Limit</p> <p>Nom = Nominal Value</p> <p>F<sub>-</sub> = Lower Fail Limit</p> <p>F<sub>+</sub> = Upper Fail Limit</p> <p>Spec<sub>-</sub> = Lower Specification Limit</p> <p>Spec<sub>+</sub> = Upper Specification Limit</p> <p>U<sub>-</sub> = Lower Uncertainty</p> <p>U<sub>+</sub> = Upper Uncertainty</p> <p>LL = Lower Limit</p> <p>UL = Upper Limit</p>		

Uncertainty Unit	Lookup Name	Formulas
TUR = Test Uncertainty Ratio		

When using the value `method6`, the uncertainty worksheet automatically selects the correct formula based on the uncertainty units. The method 6 formulas in the table are only applied when both the upper limit and lower limit are valid, and when the calculated Test Uncertainty Ratio (TUR) is determined to be  $\leq 4$ . For values greater than 4, the calculated guard band is determined to be 0.

If a nominal value (Nom) is not specified, Calibration Executive uses a default nominal value:

$$\text{Nom} = \frac{(\text{UL} + \text{LL})}{2}$$

### Custom Guard Band Calculations

In addition to the built-in guard bands, you can add user-defined custom guard bands, which modify the limits by a fixed value that is specified for each test point.

When a custom guard band is added, the prefix `Custom_` is added to the user-provided tag name to form the Lookup ID for the custom guard band. For example, if you insert a new custom guard band and enter the tag name `NewCalc`, the Lookup ID for the guard band becomes `Custom_NewCalc`.

In this way, you can define a custom description for the guard band to display on the report. You must configure the guard band notes from within the Calibration Executive application.

### Conditional Pass Runtime and Reporting Behavior

Many runtime and reporting behaviors in Calibration Executive are evaluated as simply "Passed" or "Failed" as long as the result falls within the specified range. However, you can configure runtime options to specify whether a conditional pass should evaluate to "Passed" or "Failed" for these specific behaviors.

To configure the execution and reporting behavior for a Conditional Pass:

1. From the toolbar in the main Calibration Executive window, select **Configure » Runtime Options**.

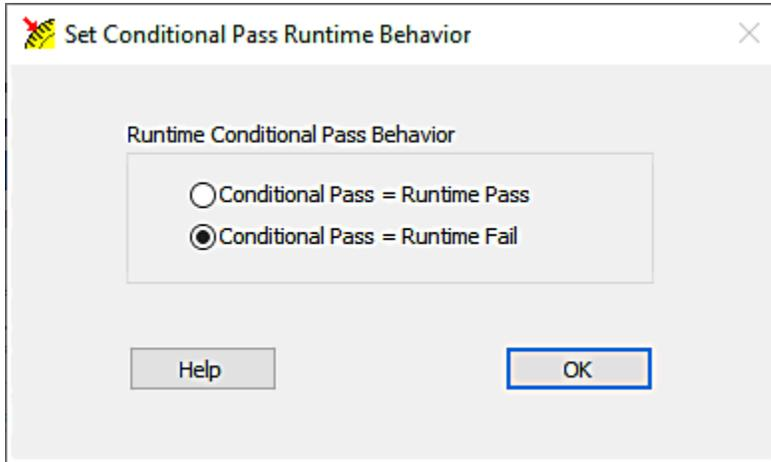

2. Select an option to specify whether a Conditional Pass is a Runtime Pass or a Runtime Fail.

By default, Calibration Executive evaluates a conditional pass as a runtime fail. This is equivalent to using the Accept Limits that are calculated from the guard band to dictate the passed/failed behavior.

The following tables show the result type for specific behaviors when guard banding is taking into consideration. A Binary type means that the result will be either "Passed" or "Failed." Conditional means that a double dagger symbol (‡) will be appended to the "Passed" or "Failed" result.

**Table 6.** Runtime status and behavior

Behavior	Result Type (Binary or Conditional)
Failed Test Point Dialog Display Condition	Binary
Step message log pass/fail status	Conditional
Test step pass/fail result in execution dialog	Binary
Overall test result dialog	Binary

**Table 7.** Printed report status

<b>Behavior</b>	<b>Result Type (Binary or Conditional)</b>
Overall As-Found Result	Conditional
Overall As-Left Result	Binary
Individual Test Point Result (as-found and as-left)	Conditional

# Calibration Procedures

Learn how to calibrate your NI hardware using Calibration Executive.

## C Series Module Calibration Procedures

Learn how to calibrate your C Series modules using Calibration Executive.

### NI 9201/9221 Calibration Procedure

Calibrate the NI 9201 and NI 9221 using Calibration Executive.

#### Calibration Executive Procedure Features

Verify Only ✓	Verify & Adjust ✓	Manual Mode ✓	Optional Adjust ✗
---------------	-------------------	---------------	-------------------

#### Approximate Test Time

30 minutes

#### Test Equipment

The following table lists the test equipment required for calibrating NI 9201/9221 modules.

**Table 312.** Test equipment for calibrating the NI 9201/9221

Instrument	Recommended Model	Requirements
Calibrator	Fluke 5700A	Use a high-precision voltage source with an output impedance of $\leq 50 \Omega$ and an accuracy that meets the following requirement for your module:  (NI 9201) Use a high-precision voltage source with an accuracy of $\leq 15$ ppm.

Instrument	Recommended Model	Requirements
		(NI 9221) Use a high-precision voltage source with an accuracy of $\leq 25$ ppm.
Chassis	cDAQ-9178	—
Connection Accessory	NI 9932	Use with NI 9201/9221 screw terminal modules.
	NI 9934	Use with NI 9201/9221 D-SUB modules.

## Test Conditions

The following setup and environmental conditions are required to ensure the NI 9201/9221 meets published specifications.

- Keep connections to the device as short as possible. Long cables and wires act as antennas, picking up extra noise that can affect measurements.
- Use shielded copper wire for all cable connections to the device. Use twisted-pair wire to eliminate noise and thermal offsets.
- Maintain an ambient temperature of  $23\text{ }^{\circ}\text{C} \pm 5\text{ }^{\circ}\text{C}$ . The device temperature will be greater than the ambient temperature.
- Keep relative humidity below 80%.
- Allow a warm-up time of at least 10 minutes to ensure that the NI 9201/9221 measurement circuitry is at a stable operating temperature.

## Device Setup

1. Install the NI 9201/9221 in slot 8 of the cDAQ-9178 chassis. Leave slots 1 through 7 on the cDAQ-9178 chassis empty.
2. Configure the hardware using Measurement & Automation Explorer (MAX).
3. Launch the Calibration Executive procedure and complete the setup wizard.



**Note** If the NI 9201/9221 module fails after calibration, return it to NI for repair or replacement.

## Test Limit Equations

The following test limits are derived from the published specifications found in the NI 9201/9221 Calibration Procedure.

**Table 9.** NI 9201/9221 Test Limit Equations

Equation Type	Equation
Accuracy	$\text{TestLimits} = \text{TestValue} \pm [\text{TestValue} * \text{GainError} (\% \text{ of Reading})] + \text{Offset}$

### Related concepts:

- [Launching a Calibration Procedure](#)

## NI 9202 Calibration Procedure

Calibrate the NI 9202 (DSUB and screw terminal) using Calibration Executive.

### Calibration Executive Procedure Features

Verify Only ✓	Verify & Adjust ✓	Manual Mode ✓	Optional Adjust ✗
---------------	-------------------	---------------	-------------------

### Approximate Test Time

Verify Only	Verify & Adjust
4 minutes	8 minutes

### Test Equipment

The following table lists the test equipment required for calibrating NI 9202 modules.

**Table 312.** Test equipment for calibrating the NI 9202

Instrument	Recommended Model	Requirements
Calibrator	Fluke 5500A	Use a high-precision voltage source with a gain error of <57 ppm and an offset error of <2 mV.

Instrument	Recommended Model	Requirements
Chassis	cDAQ-9178	—
Terminal Block*	NI 9923	—



**Note** \*The NI 9923 terminal block is used only for the DSUB variant.

## Test Conditions

The following setup and environmental conditions are required to ensure the NI 9202 meets published specifications.

- Keep connections to the device as short as possible. Long cables and wires act as antennas, picking up extra noise that can affect measurements.
- Verify that all connections to the device are secure.
- Use shielded copper wire for all cable connections to the device. Use twisted-pair wire to eliminate noise and thermal offsets.
- Maintain an ambient temperature of  $23\text{ °C} \pm 5\text{ °C}$ . The device temperature will be greater than the ambient temperature.
- Keep relative humidity below 80%.
- Allow a warm-up time of at least 10 minutes to ensure that the device measurement circuitry is at a stable operating temperature.

## Device Setup

1. Make sure the cDAQ-9178 power source is not connected.
2. Connect the cDAQ-9178 to the system safety ground.
  - a. Attach a ring lug to a 14 AWG (1.6 mm) wire.
  - b. Connect the ring lug to the ground terminal on the side of the cDAQ-9178 using the ground screw.
  - c. Attach the other end of the wire to the system safety ground.
3. Install the module in slot 8 of the cDAQ-9178 chassis. Leave slots 1 through 7 of the chassis empty.
4. Connect the cDAQ-9178 chassis to your host computer.
5. Connect the power source to the cDAQ-9178 chassis.



6. Launch Measurement & Automation Explorer (MAX).
7. Right-click the device name and select **Self-Test** to ensure that the module is working properly.

When using Fluke 55xx calibrators, the earth ground option is enabled by software during execution. If you use a 57xx calibrator with this procedure, make sure that the external ground is connected to the guard connector.



**Note** If the NI 9202 module fails after calibration, return it to NI for repair or replacement.

### Test Limit Equations

The following test limits are derived from the published specifications found in the NI 9202 Calibration Procedure.

$$\text{TestLimit} = \text{TestValue} \pm (\text{TestValue} \times \text{GainError} (\%) + \text{Range} \times \text{Percent of Range} (\%))$$

## NI 9203 Calibration Procedure

Calibrate the NI 9203 using Calibration Executive.

### Calibration Executive Procedure Features

Verify Only ✓	Verify & Adjust ✓	Manual Mode ✓	Optional Adjust ✗
---------------	-------------------	---------------	-------------------

### Approximate Test Time

Verify Only	Verify & Adjust
5 minutes	15 minutes

### Test Equipment

The following table lists the test equipment required for calibrating NI 9203 modules.

**Table 312.** Test equipment for calibrating the NI 9203

Instrument	Recommended Model	Requirements
Calibrator	Fluke 5700A	<p>If this instrument is unavailable, use a high-precision current source with an accuracy of at least 100 ppm.</p> <p>The guard must be connected to a quiet earth ground. If the calibrator does not have a guard connection, then connect the LO terminal to earth ground.</p>
Chassis	cDAQ-9178	—

## Test Conditions

The following setup and environmental conditions are required to ensure the NI 9203 meets published specifications.

- Keep connections to the device as short as possible. Long cables and wires act as antennas, picking up extra noise that can affect measurements.
- Use shielded copper wire for all cable connections to the device. Use twisted-pair wire to eliminate noise and thermal offsets.
- Maintain an ambient temperature of  $23\text{ }^{\circ}\text{C} \pm 5\text{ }^{\circ}\text{C}$ . The device temperature will be greater than the ambient temperature.
- Keep relative humidity below 80%.
- Allow a warm-up time of at least 10 minutes to ensure that the NI 9203 measurement circuitry is at a stable operating temperature.

## Device Setup

1. Install the NI 9203 in slot 8 of the cDAQ-9178 chassis. Leave slots 1 through 7 on the cDAQ-9178 chassis empty.
2. Configure the hardware using Measurement & Automation Explorer (MAX).
3. Launch the Calibration Executive procedure and complete the setup wizard.

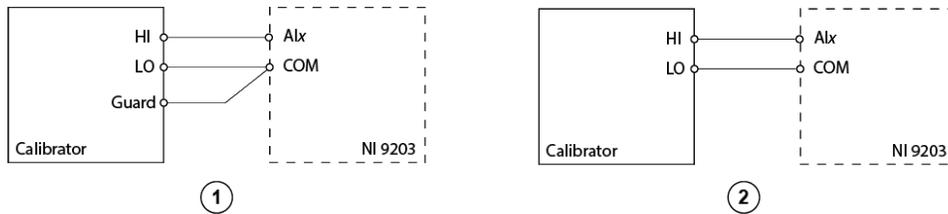

**Note** If the NI 9203 module fails after calibration, return it to NI for repair or replacement.

**Figure 1.** Accuracy Connections for the NI 9203

1. Connections when using a calibrator with a guard connection.
2. Connections when using a calibrator with no guard connection.



**Note** If the calibrator outputs are truly floating, connect the negative output to a quiet earth ground as well as COM to give the entire system a ground reference.

## Test Limit Equations

The following test limits are derived from the published specifications found in the ***NI 9203 Calibration Procedure***.

**Table 12.** NI 9203 Test Limit Equations

Equation Type	Equation
Accuracy	$\text{TestLimits} = \text{TestValue} \pm \text{Absolute Accuracy}$ <ul style="list-style-type: none"> <li>• <math>\text{Absolute Accuracy} = \text{TestValue} * \text{GainError} + \text{Range} * \text{Offset error}</math></li> </ul>

## Related concepts:

- [Launching a Calibration Procedure](#)

## NI 9205/9206 Calibration Procedure

Calibrate the NI 9205 and NI 9206 using Calibration Executive.

## Calibration Executive Procedure Features

Verify Only ✓	Verify & Adjust ✓	Manual Mode ✓	Optional Adjust ⓧ
---------------	-------------------	---------------	-------------------

### Approximate Test Time

5 minutes

### Test Equipment

The following table lists the test equipment required for calibrating NI 9205/9206 modules.

**Table 312.** Test equipment for calibrating the NI 9205/9206

Instrument	Recommended Model	Requirements
Calibrator	Fluke 5700A	If this instrument is unavailable, use a high-precision voltage source with an accuracy of at least 10 ppm.
Chassis	cDAQ-9178	—
Connection Accessory	NI 9940	Use with NI 9205/9206 modules with screw terminal.
	NI 9933	Use with NI 9205/9206 modules with DSUB.

### Test Conditions

The following setup and environmental conditions are required to ensure the NI 9205/9206 meets published specifications.

- Keep connections to the device as short as possible. Long cables and wires act as antennas, picking up extra noise that can affect measurements.
- Use shielded copper wire for all cable connections to the device. Use twisted-pair wire to eliminate noise and thermal offsets.
- Maintain an ambient temperature of  $23\text{ °C} \pm 5\text{ °C}$ . The device temperature will be greater than the ambient temperature.
- Keep relative humidity below 80%.
- Allow a warm-up time of at least 10 minutes to ensure that the NI 9205/9206 measurement circuitry is at a stable operating temperature.

## Device Setup

1. Install the NI 9205/9206 in slot 8 of the cDAQ-9178 chassis. Leave slots 1 through 7 on the cDAQ-9178 chassis empty.
2. Configure the hardware using Measurement & Automation Explorer (MAX).
3. Launch the Calibration Executive procedure and complete the setup wizard.



**Note** If the NI 9205/9206 module fails after calibration, return it to NI for repair or replacement.

## Test Limit Equations

The following test limits are derived from the published specifications found in the NI 9205/9206 Calibration Procedure.

**Table 14.** NI 9205/9206 Test Limit Equations

Equation Type	Equations
Accuracy	$\text{TestPoints} = \text{TestValue} \pm (\text{TestValue} * \text{GainError} + \text{Range} * \text{OffsetError} + \text{NoiseUncertainty})$ <ul style="list-style-type: none"> <li>• <math>\text{GainError} = \text{ResidualAIGainError} + \text{GainTempco} * (\text{TempChangeFromLastInternalCal}) + \text{ReferenceTempco} * (\text{TempChangeFromLastExternalCal})</math></li> <li>• <math>\text{OffsetError} = \text{ResidualAIOffsetError} + \text{OffsetTempco} * (\text{TempChangeFromLastInternalCal}) + \text{INL\_Error}</math></li> <li>• <math>\text{NoiseUncertainty} = \text{RandomNoise} * 3 / \text{for a coverage factor of } 3 \Sigma \text{ and averaging } 100 \text{ points}</math></li> </ul>

### Related concepts:

- [Launching a Calibration Procedure](#)

# NI 9207 Calibration Procedure

Calibrate the NI 9207 using Calibration Executive.

## Calibration Executive Procedure Features

Verify Only ✓	Verify & Adjust ✓	Manual Mode ✓	Optional Adjust ✗
---------------	-------------------	---------------	-------------------

## Approximate Test Time

Warmup	Verify Only	Verify & Adjust
10 minutes	22 minutes	66 minutes

## Test Equipment

The following table lists the test instruments required for calibrating the NI 9207.

**Table 312.** Test equipment for calibrating the NI 9207

Instrument	Recommended Model	Requirements
Source	Fluke 5700A	If this instrument is unavailable, use a source with an accuracy $\leq 100$ ppm.
CompactDAQ Chassis	cDAQ-9178	—
Connection Accessory*	NI 9923	Front-mount terminal block for 37-pin DSUB Modules.
Connection Accessory**	NI 9974	36-pos spring terminal connector block.



### Note

- \* The NI 9923 terminal block is used only for the DSUB variant.
- \*\* The NI 9974 connector block is used only for the spring terminal

variant.

## Test Conditions

The following setup and environmental conditions are required to ensure the NI 9207 meets published specifications.

- Keep connections to the device as short as possible. Long cables and wires act as antennas, picking up extra noise that can affect measurements.
- Verify that all connections to the device are secure.
- Use shielded copper wire for all cable connections to the device. Use twisted-pairs wire to eliminate noise and thermal offsets.
- Maintain an ambient temperature of  $23 \pm 5$  °C. The device temperature will be greater than the ambient temperature.
- Keep relative humidity below 80%.
- Allow a warm-up time of at least 10 minutes to ensure that the NI 9207 measurement circuitry is at a stable operating temperature.

## Device Setup

1. Install the NI 9207 in slot 8 of the cDAQ-9178 chassis. Leave slots 1 through 7 of the cDAQ-9178 chassis empty.
2. Launch Measurement & Automation Explorer (MAX).
3. Right-click the device name and select **Self-Test** to ensure that the device is working properly.

## Test Limit Equations

The following test limits are derived from the published specifications.

**Table 16.** NI 9207 Test Limit Equations

Equation Type	Equation
Voltage Accuracy Verification	$\text{TestLimits} = \text{TestValue} \pm \text{TestMeasurementRange}$ <ul style="list-style-type: none"> <li>• <math>\text{TestMeasurementRange} = \text{abs}(\text{TestValue} * </math></li> </ul>

Equation Type	Equation
	$\% \text{ of Reading} + (\text{Range} * \% \text{ of Range})$ <ul style="list-style-type: none"> <li>• Range = 10.4 V</li> <li>• % of Reading = 0.100%</li> <li>• % of Range = 0.020%</li> </ul>
Current Accuracy Verification	$\text{TestLimits} = \text{TestValue} \pm \text{TestMeasurementRange}$ <ul style="list-style-type: none"> <li>• <math>\text{TestMeasurementRange} = \text{abs}(\text{TestValue} * \% \text{ of Reading} + (\text{Range} * \% \text{ of Range}))</math></li> <li>• Range = 22mA</li> <li>• % of Reading = 0.150%</li> <li>• % of Range = 0.012%</li> </ul>

## NI 9208 Calibration Procedure

Calibrate the NI 9208 using Calibration Executive.

### Calibration Executive Procedure Features

Verify Only ✓	Verify & Adjust ✓	Manual Mode ✓	Optional Adjust ✗
---------------	-------------------	---------------	-------------------

### Approximate Test Time

Warmup	Verify Only	Verify & Adjust
10 minutes	14 minutes	42 minutes

### Test Equipment

The following table lists the test instruments required for calibrating the NI 9208.

**Table 312.** Test equipment for calibrating the NI 9208

Instrument	Recommended Model	Requirements
Source	Fluke 5700A	Use a high-precision current source with an accuracy



Instrument	Recommended Model	Requirements
		≤100 ppm.
CompactDAQ Chassis	cDAQ-9178	—
Connection Accessory*	NI 9923	Front-mount terminal block for 37-pin DSUB Modules.
Connection Accessory**	NI 9974	36-pos spring terminal connector block.



## Note

- \* The NI 9923 terminal block is used only for the DSUB variant.
- \*\* The NI 9974 connector block is used only for the spring terminal variant.

## Test Conditions

The following setup and environmental conditions are required to ensure the NI 9208 meets published specifications.

- Keep connections to the device as short as possible. Long cables and wires act as antennas, picking up extra noise that can affect measurements.
- Verify that all connections to the device are secure.
- Use shielded copper wire for all cable connections to the device. Use twisted-pairs wire to eliminate noise and thermal offsets.
- Maintain an ambient temperature of  $23 \pm 5$  °C. The device temperature will be greater than the ambient temperature.
- Keep relative humidity below 80%.
- Allow a warm-up time of at least 10 minutes to ensure that the NI 9208 measurement circuitry is at a stable operating temperature.

## Device Setup

1. Install the NI 9208 in slot 8 of the cDAQ-9178 chassis. Leave slots 1 through 7 of the

- cDAQ-9178 chassis empty.
- 2. Launch Measurement & Automation Explorer (MAX).
- 3. Right-click the device name and select **Self-Test** to ensure that the device is working properly.

### Test Limit Equations

The following test limits are derived from the published specifications.

**Table 18.** NI 9208 Test Limit Equations

Equation Type	Equation
Current Accuracy Verification	$\text{TestLimits} = \text{TestValue} \pm \text{TestMeasurementRange}$ <ul style="list-style-type: none"> <li>• <math>\text{TestMeasurementRange} = \text{abs}(\text{TestValue} * \% \text{ of Reading}) + (\text{Range} * \% \text{ of Range})</math></li> <li>• Range = 22mA</li> <li>• % of Reading = 0.132%</li> <li>• % of Range = 0.010%</li> </ul>

## NI 9209 Calibration Procedure

Calibrate the NI 9209 using Calibration Executive.

### Calibration Executive Procedure Features

Verify Only ✓	Verify & Adjust ✓	Manual Mode ✓	Optional Adjust ✗
---------------	-------------------	---------------	-------------------

### Approximate Test Time

Warmup	Verify Only	Verify & Adjust
10 minutes	12.5 minutes	17.5 minutes

### Test Equipment

The following table lists the test instruments required for calibrating the NI 9209.

**Table 312.** Test equipment for calibrating the NI 9209

Instrument	Recommended Model	Requirements
Source	Fluke 5500A	Use a source with gain error $\leq 260$ ppm and an offset error $\leq 70$ $\mu$ V.
CompactDAQ Chassis	cDAQ-9178	—
Connection Accessory*	NI 9923	Front-mount terminal block for 37-pin DSUB Modules.
Connection Accessory**	NI 9974	36-pos spring terminal connector block.



### Note

- \* The NI 9923 terminal block is used only for the DSUB variant.
- \*\* The NI 9974 connector block is used only for the spring terminal variant.

### Test Conditions

The following setup and environmental conditions are required to ensure the NI 9209 meets published specifications.

- Keep connections to the device as short as possible. Long cables and wires act as antennas, picking up extra noise that can affect measurements.
- Verify that all connections to the device are secure.
- Use shielded copper wire for all cable connections to the device. Use twisted-pairs wire to eliminate noise and thermal offsets.
- Maintain an ambient temperature of  $23 \pm 5$  °C. The device temperature will be greater than the ambient temperature.
- Keep relative humidity below 80%.
- Allow a warm-up time of at least 10 minutes to ensure that the NI 9209 measurement circuitry is at a stable operating temperature.

## Device Setup

1. Install the NI 9209 in slot 8 of the cDAQ-9178 chassis. Leave slots 1 through 7 of the cDAQ-9178 chassis empty.
2. Launch Measurement & Automation Explorer (MAX).
3. Right-click the device name and select **Self-Test** to ensure that the device is working properly.

## Test Limit Equations

The following test limits are derived from the published specifications.

**Table 20.** NI 9209 Test Limit Equations

Equation Type	Equation
Current Accuracy Verification	$\text{TestLimits} = \text{TestValue} \pm \text{TestMeasurementRange}$ <ul style="list-style-type: none"> <li>• <math>\text{TestMeasurementRange} = \text{abs}(\text{TestValue} * \% \text{ of Reading}) + (\text{Range} * \% \text{ of Range})</math></li> <li>• <math>\text{Range} = 10.4 \text{ V}</math></li> <li>• For differential channels: <ul style="list-style-type: none"> <li>◦ <math>\% \text{ of Reading} = 0.097\%</math></li> <li>◦ <math>\% \text{ of Range} = 0.0055\%</math></li> </ul> </li> <li>• For single-ended channels: <ul style="list-style-type: none"> <li>◦ <math>\% \text{ of Reading} = 0.093\%</math></li> <li>◦ <math>\% \text{ of Range} = 0.0053\%</math></li> </ul> </li> </ul>

## NI 9210 Calibration Procedure

Calibrate the NI 9210 with mini-TC or the NI 9210 with spring terminal using Calibration Executive.

### Calibration Executive Procedure Features

Verify Only ✓	Verify & Adjust ✓	Manual Mode ✓	Optional Adjust ⓧ
---------------	-------------------	---------------	-------------------

## Approximate Test Time

Warmup	Verify Only	Verify & Adjust
10 minutes	3 minutes	5 minutes

## Test Equipment

The following table lists the test equipment required for calibrating NI 9210 modules.

**Table 312.** Test equipment for calibrating the NI 9210

Instrument	Recommended Model	Requirements
Calibrator	Fluke 5522A locked in the 3.3 V range	A high-precision voltage source with $\leq 7 \mu\text{V}$ of uncertainty at 75 mV and $\leq 2 \mu\text{V}$ of uncertainty at 0 V, and an output impedance of $< 5 \Omega$ .
Chassis	cDAQ-9178	—
Mini Thermocouple Connector (x4)	Omega SMPW-U-M	U type  <b>Note</b> This instrument is required only for the NI 9210 with mini-TC.
Connector Accessory	NI Part Number: 771464-01	 <b>Note</b> This instrument is required only for the NI 9210 with spring terminal.

## Test Conditions

The following setup and environmental conditions are required to ensure the NI 9210 meets published specifications.

- Keep connections to the device as short as possible. Long cables and wires act as antennas, picking up extra noise that can affect measurements.
- Verify that all connections, including front panel connections, are secure.
- Use shielded copper wire for all cable connections to the device. Connect the calibrator end of the shield to the guard terminal of the calibrator and the NI 9210

end of the shield to the COM terminal of the NI 9210.

- Maintain an ambient temperature of  $23 \pm 5$  °C. The device temperature will be greater than the ambient temperature.
- Keep relative humidity below 80%.
- Allow a warm-up time of at least 10 minutes to ensure that the NI 9210 measurement circuitry is at a stable operating temperature.

## Device Setup

1. Make sure the cDAQ-9178 power source is not connected.
2. Attach a ring lug to a 14 AWG (1.6 mm) wire. Connect the ring lug to the ground terminal on the side of the cDAQ-9178 using the ground screw. Attach the other end of the wire to the system safety ground.
3. Install the module in slot 8 of the cDAQ-9178 chassis. Leave slots 1 through 7 of the cDAQ-9178 chassis empty.
4. Connect the cDAQ-9178 chassis to your host computer.
5. Connect the power source to the cDAQ-9178 chassis.
6. Launch Measurements & Automation Explorer (MAX).
7. Right-click the device name and select **Self-Test** to ensure that the device is working properly.



**Note** If any test fails Re-Verification after performing an adjustment, verify that you have met the Test Conditions before returning your device to NI.

## Test Limit Equations

Test limits can be found in the published **NI 9210 Calibration Procedure**, which is available at [ni.com/docs](http://ni.com/docs).

## NI 9211 Calibration Procedure

Calibrate the NI 9211 using Calibration Executive.

### Calibration Executive Procedure Features

Verify Only ✓	Verify & Adjust ✓	Manual Mode ✓	Optional Adjust ✗
---------------	-------------------	---------------	-------------------

## Approximate Test Time

15 minutes

## Test Equipment

The following table lists the test equipment required for calibrating NI 9211 modules.

**Table 312.** Test equipment for calibrating the NI 9211

Instrument	Recommended Model	Requirements
Calibrator	Fluke 5520A using the 3.3 V range*	A high-precision voltage source with $\leq 7 \mu\text{V}$ of uncertainty at 75 mV and $\leq 2 \mu\text{V}$ of uncertainty at 0 V and an output impedance of $< 5 \Omega$ .
Chassis	cDAQ-9178	—
Connection Accessory	NI 9932	—



**Note** \*Because the 3.3 V range has a low output impedance.

## Test Conditions

The following setup and environmental conditions are required to ensure the NI 9211 meets published specifications.

- Keep connections to the device as short as possible. Long cables and wires act as antennas, picking up extra noise that can affect measurements.
- Use shielded copper wire for all cable connections to the device. Use twisted-pair wire to eliminate noise and thermal offsets.
- Maintain an ambient temperature of  $23 \text{ }^\circ\text{C} \pm 5 \text{ }^\circ\text{C}$ . The device temperature will be greater than the ambient temperature.
- Keep relative humidity below 80%.
- Allow a warm-up time of at least 10 minutes to ensure that the NI 9211 measurement circuitry is at a stable operating temperature.

## Device Setup

1. Install the NI 9211 in slot 8 of the cDAQ-9178 chassis. Leave slots 1 through 7 on the cDAQ-9178 chassis empty.
2. Configure the hardware using Measurement & Automation Explorer (MAX).
3. Launch the Calibration Executive procedure and complete the setup wizard.



**Note** If the NI 9211 module fails after calibration, return it to NI for repair or replacement.

## Test Limit Equations

The following test limits are derived from the published specifications found in the NI 9211 Calibration Procedure.

**Table 23.** NI 9211 Test Limit Equations

Equation Type	Equation
Accuracy	$\text{TestLimits} = \text{TestValue} \pm (\text{TestValue} * \% \text{ of Reading} + \text{Offset Error})$

### Related concepts:

- [Launching a Calibration Procedure](#)

## NI 9212 Calibration Procedure

Calibrate the NI 9212 using Calibration Executive.

### Calibration Executive Procedure Features

Verify Only ✓	Verify & Adjust ✓	Manual Mode ✗	Optional Adjust ✗
---------------	-------------------	---------------	-------------------

### Approximate Test Time

Verify Only	Verify & Adjust
30 minutes	50 minutes



## Test Equipment

The following table lists the test equipment required for calibrating NI 9212 module.

**Table 312.** Test equipment for calibrating the NI 9212

Instrument	Recommended Model	Where Used	Requirements
Calibrator	Fluke 5522A locked in the 3.3 V range	Voltage Verification, Voltage Adjustment, CJC Adjustment	A high-precision voltage source with an accuracy of $\leq 70$ ppm when sourcing up to 50 $\mu\text{A}$ .
	Fluke 5522A	CJC Verification	A high-precision resistance source with 2-wire compensation and an accuracy of at least <ul style="list-style-type: none"> <li>• 660 ppm at 1,099.999 <math>\Omega</math> range.</li> <li>• 18 ppm at 32,999.99 <math>\Omega</math> range.</li> <li>• 30 ppm at 109,999.99 <math>\Omega</math> range.</li> </ul> If the resistance source does not have 2-wire compensation, the leadwire resistance must be included in the total resistance source accuracy.
Chassis	cDAQ-9178	All	—
Connection Accessory	CAL-9212	All	—
Digital Multimeter	PXI-4071	CJC Adjustment	A multiranging 7 1/2-digit digital multimeter with an accuracy of at least <ul style="list-style-type: none"> <li>• 8 ppm at 100 mV range.</li> <li>• 6 ppm at 10 V range.</li> </ul>

## Test Conditions

The following setup and environmental conditions are required to ensure the NI 9212 meets published specifications.

- Keep connections to the device as short as possible. Long cables and wires act as antennas, picking up extra noise that can affect measurements.
- verify that all connections to the NI 9212 are secure.
- Use shielded copper wire for all cable connections to the device. Use twisted-pair wire to eliminate noise and thermal offsets.
- Maintain an ambient temperature of  $23\text{ }^{\circ}\text{C} \pm 5\text{ }^{\circ}\text{C}$ . The device temperature will be greater than the ambient temperature.
- Keep relative humidity below 80%.
- Allow a warm-up time of at least 15 minutes to ensure that the NI 9212 measurement circuitry is at a stable operating temperature.

## Device Setup

1. Install the NI 9212 in slot 8 of the cDAQ-9178 chassis. Leave slots 1 through 7 of the chassis empty.
2. Configure the hardware using Measurement & Automation Explorer (MAX).
3. Launch the Calibration Executive procedure and complete the setup wizard.



**Note** If the NI 9212 module fails after calibration, return it to NI for repair or replacement.

## Test Limit Equations

The following test limits are derived from the published specifications found in the NI 9212 Calibration Procedure.

**Table 25.** NI 9212 Test Limit Equations

Equation Type	Equation
Voltage Accuracy Verification	$\text{TestLimits} = \text{TestValue} \pm \text{Test Range}$ $\text{Test Range} = \text{ABS}(\text{TestValue} * (\text{ppm of Reading})) + (\text{Range} * (\text{ppm of Range}))$ $\text{Range} = \pm 78.125 \text{ mV}$ <p>Accuracy:</p>

Equation Type	Equation																					
	<ul style="list-style-type: none"> <li>• High Resolution Mode                             <ul style="list-style-type: none"> <li>◦ ppm of Reading = 212.69</li> <li>◦ ppm of Range = 65.14</li> </ul> </li> <li>• Best 50/60 Hz Rejection Mode                             <ul style="list-style-type: none"> <li>◦ ppm of Reading = 215.20</li> <li>◦ ppm of Range = 66.14</li> </ul> </li> <li>• High Speed Mode                             <ul style="list-style-type: none"> <li>◦ ppm of Reading = 273.22</li> <li>◦ ppm of Range = 71.57</li> </ul> </li> </ul>																					
CJC Accuracy Verification	<p>Resistance = 28000 * (Voltage / (2.5 - Voltage))</p> <p>UpperLimit = [(R<sub>test</sub> * (V<sub>ref</sub> / (R<sub>pull_up</sub> + R<sub>pull_down</sub> + R<sub>test</sub>))) * (1 + PPM<sub>reading</sub>) + V<sub>offset</sub>] * (R<sub>pull_up</sub> + R<sub>pull_down</sub>) / (V<sub>ref</sub> - [(R<sub>test</sub> * (V<sub>ref</sub> / (R<sub>pull_up</sub> + R<sub>pull_down</sub> + R<sub>test</sub>))) * (1 + PPM<sub>reading</sub>) + V<sub>offset</sub>])</p> <p>LowerLimit = (2 * R<sub>test</sub>) - UpperLimit</p> <ul style="list-style-type: none"> <li>• R<sub>test</sub> = TestValue (Resistance)</li> <li>• V<sub>ref</sub> = 2.5 V (Reference Voltage)</li> <li>• R<sub>pull_up</sub> = 12 kΩ</li> <li>• R<sub>pull_down</sub> = 16 kΩ</li> <li>• V<sub>offset</sub> = PPM<sub>range</sub> * 2.5 V</li> </ul>																					
Accuracy	<table border="1" data-bbox="820 1375 1464 1787"> <thead> <tr> <th>Mode</th> <th>Value (Ω)</th> <th>ppm of Reading</th> <th>ppm of Range</th> </tr> </thead> <tbody> <tr> <td rowspan="3">High Resolution</td> <td>1000</td> <td>649.21</td> <td>33.88</td> </tr> <tr> <td>19000</td> <td>453.08</td> <td>28.98</td> </tr> <tr> <td>100000</td> <td>253.19</td> <td>23.99</td> </tr> <tr> <td rowspan="2">Best 50/60 Hz Rejection</td> <td>1000</td> <td>656.5</td> <td>37.28</td> </tr> <tr> <td>19000</td> <td>460.37</td> <td>32.39</td> </tr> </tbody> </table>	Mode	Value (Ω)	ppm of Reading	ppm of Range	High Resolution	1000	649.21	33.88	19000	453.08	28.98	100000	253.19	23.99	Best 50/60 Hz Rejection	1000	656.5	37.28	19000	460.37	32.39
Mode	Value (Ω)	ppm of Reading	ppm of Range																			
High Resolution	1000	649.21	33.88																			
	19000	453.08	28.98																			
	100000	253.19	23.99																			
Best 50/60 Hz Rejection	1000	656.5	37.28																			
	19000	460.37	32.39																			

Equation Type	Equation			
	Mode	Value ( $\Omega$ )	ppm of Reading	ppm of Range
		100000	260.48	27.39
	High Speed	1000	704.92	63.34
		19000	508.78	951.43
		100000	308.9	1243.43

### Related concepts:

- [Launching a Calibration Procedure](#)

## TB-9212 Calibration Procedure

Calibrate the TB-9212 with mini-TC or the TB-9212 with screw terminal using Calibration Executive.

For more information on these terminal block variants, refer to the ***TB-9212 Calibration Procedure*** on [ni.com/docs](http://ni.com/docs).

### Calibration Executive Procedure Features

Verify Only ✓	Verify & Adjust ✘	Manual Mode ✓	Optional Adjust ✘
---------------	-------------------	---------------	-------------------

### Approximate Test Time

18 minutes

### Test Equipment

The following table lists the test instruments required for calibrating the TB-9212 terminal blocks.

**Table 26.** Test equipment for calibrating the TB-9212

Instrument		Recommended Model	Requirements
Thermocouple Calibrator		Ectron 1140A	If this instrument is unavailable, use a high precision thermocouple source with an accuracy of $\leq 0.06$ °C and an output impedance of $\leq 10$ $\Omega$ .
C Series Module		NI 9212	An NI 9212 module that is verified to be within product specifications.
Chassis		cDAQ-9178	—
Barrier Strip Assembly	Thermocouple Wire	TT-E-24-SLE-100	E-type SLE 24 AWG, 20 m to 30 m.
	Mini Thermocouple Connector	Omega SMPW-E-M	E-type, must fit the output terminal of the thermocouple calibrator.
	Thermocouple Barrier Strips	Omega BS16A	8 channels.
	Thermocouple Barrier Strip Jackets (x8)	Omega BSJ-E	E-type, 8 channels.
	Thermocouple Spade Lugs (x32)	Omega SLCH-20	16 lugs of chromel to match the E-type wires.
		Omega SLCO-20	16 lugs of constantan to match the E-type wires.
	Spade-Lug Crimping Tool	Omega CRIMPING TOOL-P	Must effectively crimp the spade lugs with the 24 AWG wire.
Mini Thermocouple Connector (x8)	Omega SMPW-U-M	U type  <b>Note</b> This instrument is required only for the TB-9212 with mini-TC. Refer to the Barrier Strip Assembly figure.	

## Test Conditions

The following setup and environmental conditions are required to ensure the TB-9212

meets published specifications.

- Keep connections to the device as short as possible. Long cables and wires act as antennas, picking up extra noise that can affect measurements.
- Verify that all connections to the device are secure.
- Use thermocouple wire for all cable connections to the TB-9212.
- Maintain an ambient temperature of  $23\text{ }^{\circ}\text{C} \pm 5\text{ }^{\circ}\text{C}$ . The device temperature will be greater than the ambient temperature.
- Keep relative humidity below 80%.
- Allow a warm-up time of at least 15 minutes to ensure that the NI 9212 measurement circuitry is at a stable operating temperature.

## Device Setup

1. Make sure the cDAQ-9178 power source is not connected.
2. Connect the cDAQ-9178 to the system safety ground.
  - a. Attach a ring lug to a 14 AWG (1.6 mm) wire.
  - b. Connect the ring lug to the ground terminal on the side of the cDAQ-9178 using the ground screw.
  - c. Attach the other end of the wire to the system safety ground.
3. Install the NI 9212 in slot 8 of the cDAQ-9178 chassis. Leave slots 1 through 7 of the cDAQ-9178 chassis empty.



**Note** When multiple NI 9212 measurement devices are configured, you may have the option to calibrate multiple TB-9212 terminal blocks in a single session. Because only one measurement device can be configured as an instrument for the session, each terminal block must be connected to the selected measurement device during its calibration session.

4. Connect the cDAQ-9178 chassis to your host computer.
5. Connect the power source to the cDAQ-9178 chassis.
6. Launch Measurements & Automation Explorer (MAX).
7. Right-click the device name and select **Self-Test** to ensure that the device is working properly.

### Barrier Strip Assembly

Figure 1. Barrier Strip Assembly for TB-9212 with Screw Terminal (a) and TB-9212 with mini-TC (b)

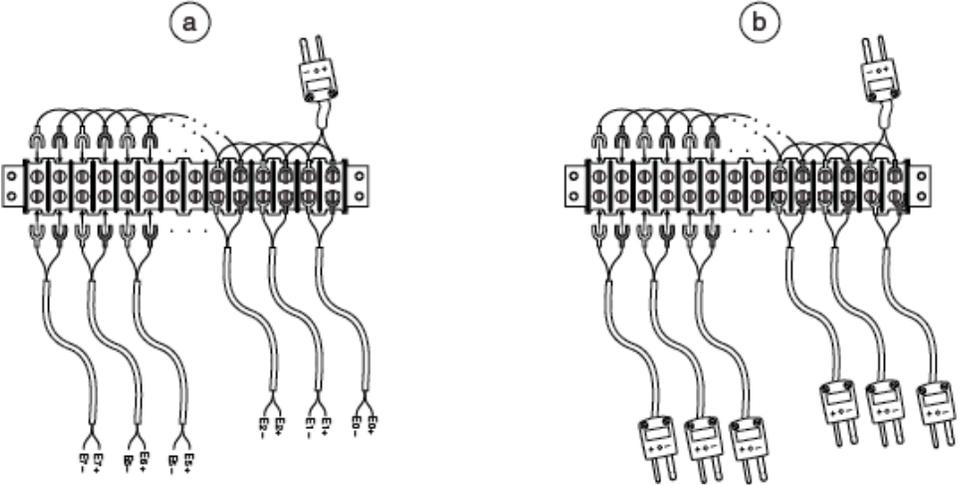

### Test Limit Equations

The following test limits are derived from the published specifications.

Table 27. TB-9212 Test Limit Equations

Equation Type	Equation
Temperature Accuracy	$\text{ErrorLimits} = \text{abs}(\text{Temp}_{\text{channel}} - \text{Temp}_{\text{CJC}})$ $\text{Temp}_{\text{error}}(\text{T}_{\text{TC}}, \text{T}_{\text{CJ}}) = \text{ErrorLimits}$ $\text{Temp}_{\text{error}}(\text{T}_{\text{TC}}, \text{T}_{\text{CJ}}) = \text{T}_{\text{E}} * [\text{V}_{\text{MEASURED}}(\text{T}_{\text{TC}}, \text{T}_{\text{CJ}}) + \text{V}_{\text{Error\_MODULE}}(\text{T}_{\text{TC}}) + \text{V}_{\text{E}}(\text{T}_{\text{CJ}} + \text{T}_{\text{CJ\_err}})] - \text{T}_{\text{TC}}$ <ul style="list-style-type: none"> <li>• <math>\text{T}_{\text{TC}}</math> = Thermocouple Temperature, 0 °C</li> <li>• <math>\text{T}_{\text{CJ}}</math> = Typical Cold Junction Temperature, 23 °C</li> <li>• <math>\text{V}_{\text{MEASURED}}(\text{T}_{\text{TC}}, \text{T}_{\text{CJ}}) = \text{V}_{\text{E}}(\text{T}_{\text{TC}}) - \text{V}_{\text{E}}(\text{T}_{\text{CJ}})</math></li> <li>• <math>\text{V}_{\text{Error\_MODULE}}(\text{T}_{\text{TC}})</math> = Voltage Error Limit at <math>\text{T}_{\text{TC}}</math></li> <li>• <math>\text{T}_{\text{CJ\_err}}</math> = Temperate error range, <math>\pm 5</math> °C</li> </ul>

# NI 9213 Calibration Procedure

Calibrate the NI 9213 using Calibration Executive.

## Calibration Executive Procedure Features:

Verify Only ✓	Verify & Adjust ⓧ	Manual Mode ✓	Optional Adjust ⓧ
---------------	-------------------	---------------	-------------------

## Approximate Test Time

10 minutes

## Test Equipment

The following table lists the test equipment required for calibrating NI 9213 modules.

**Table 312.** Test equipment for calibrating the NI 9213

Instrument	Recommended Model	Requirements
Calibrator	Fluke 5520A/ 5522A using the 3.3 V range*	If this instrument is unavailable, use a high-precision voltage source with an accuracy of at least 40 ppm and an output impedance of less than or equal to 3.125 $\Omega$ . <sup>†</sup>
Chassis	cDAQ-9178	—



### Note

- \*Because the 3.3 V range has a low output impedance.
- <sup>†</sup>This output impedance assumes 16 channels are connected to the calibrator. If you are connecting less than 16 channels to the calibrator, you can calculate the output impedance for the calibrator using the following equation:

$$\text{CalOutMax} = (50 \Omega/\text{Ch}) - R_{\text{lead}}$$



where

- CalOutMax is the maximum calibrator output impedance allowed to properly calibrate the NI 9213
- Ch is the number of channels connected to the calibrator
- $R_{\text{lead}}$  is the resistance of the cable connecting the calibrator to the NI 9213

## Test Conditions

The following setup and environmental conditions are required to ensure the NI 9213 meets published specifications.

- Keep connections to the device as short as possible. Long cables and wires act as antennas, picking up extra noise that can affect measurements.
- Use shielded copper wire for all cable connections to the device. Use twisted-pair wire to eliminate noise and thermal offsets.
- Maintain an ambient temperature of  $23\text{ }^{\circ}\text{C} \pm 5\text{ }^{\circ}\text{C}$ . The device temperature will be greater than the ambient temperature.
- Keep relative humidity below 80%.
- Allow a warm-up time of at least 10 minutes to ensure that the NI 9213 measurement circuitry is at a stable operating temperature.

## Device Setup

1. Install the NI 9213 in slot 8 of the cDAQ-9178 chassis. Leave slots 1 through 7 on the cDAQ-9178 chassis empty.
2. Configure the hardware using Measurement & Automation Explorer (MAX).
3. Launch the Calibration Executive procedure and complete the setup wizard.



**Note** If the NI 9213 module fails after calibration, return it to NI for repair or replacement.

## Test Limit Equations

The following test limits are derived from the published specifications found in the

## NI 9213 Calibration Procedure.

**Table 29.** NI 9213 Test Limit Equations

Equation Type	Equation
Accuracy	$\text{TestLimits} = \text{TestValue} \pm [\text{TestValue} * \text{GainError} (\%) + \text{Range} * \text{OffsetError} (\%)]$

### Related concepts:

- [Launching a Calibration Procedure](#)

## NI 9214 Calibration Procedure

Calibrate the NI 9214 using Calibration Executive.

### Calibration Executive Procedure Features

Verify Only ✓	Verify & Adjust ✓	Manual Mode ✓	Optional Adjust ✗
---------------	-------------------	---------------	-------------------

### Approximate Test Time

80 minutes

### Test Equipment

The following table lists the test instruments required for calibrating the NI 9214.

**Table 312.** Test equipment for calibrating the NI 9214

Instrument	Recommended Model	Specification	Requirements
Calibrator	Fluke 5520A/ 5522A locked in the 3.3 V range	Thermocouple Verification, Adjustment	If that instrument is unavailable, use a high-precision voltage source with an accuracy of 20 ppm or better when sourcing up to 50 $\mu\text{A}$ .
	Fluke 5520A, Fluke 5522A	CJC Verification,	If this instrument is unavailable for resistance accuracy verification and adjustment, use a high-

Instrument	Recommended Model	Specification	Requirements
		Adjustment	precision resistance source with an accuracy of 150 ppm 2-wire compensation or better. If the resistance source does not have 2-wire compensation, the leadwire resistance must be included in the total resistance source accuracy.
Chassis	cDAQ-9178	All	—
Connection Accessory	NI CAL-9214	Thermocouple Verification, CJC Verification, Adjustment	—

## Test Conditions

The following setup and environmental conditions are required to ensure the NI 9214 meets published specifications.

- Keep connections to the device as short as possible. Long cables and wires act as antennas, picking up extra noise that can affect measurements.
- Verify that all connections to the device are secure.
- Use shielded copper wire for all cable connections to the device. Use twisted-pairs wire to eliminate noise and thermal offsets.
- Maintain an ambient temperature of  $23\text{ °C} \pm 5\text{ °C}$ . The device temperature will be greater than the ambient temperature.
- Keep relative humidity below 80%.
- Allow a warm-up time of at least 15 minutes to ensure that the NI 9214 measurement circuitry is at a stable operating temperature.

## Device Setup

1. Make sure the cDAQ-9178 power source is not connected.
2. Attach a ring lug to a 14 AWG (1.6 mm) wire. Connect the ring lug to the ground terminal on the side of the cDAQ-9178 using the ground screw. Attach the other

end of the wire to the system safety ground.

3. Install the NI 9214 in slot 8 of the cDAQ-9178 chassis. Leave slots 1 through 7 of the cDAQ-9178 chassis empty.
4. Connect the cDAQ-9178 chassis to your host computer.
5. Connect the power source to the cDAQ-9178 chassis.
6. Launch Measurements & Automation Explorer (MAX).
7. Right-click the device name and select **Self-Test** to ensure that the device is working properly.

### Test Limit Equations

The following test limits are derived from the published specifications.

**Table 31.** NI 9214 Test Limit Equations

Equation Type	Equation
Voltage Accuracy Verification	<p>TestLimits = TestValue ± TestRange</p> <p>TestRange = abs(TestValue * Reading Accuracy) + (Range * Range Accuracy)</p> <p>Range = ±78.125 mV</p> <p>Accuracy:</p> <ul style="list-style-type: none"> <li>• High Resolution Mode                             <ul style="list-style-type: none"> <li>◦ ppm of Reading = 440</li> <li>◦ ppm of Range = 18</li> </ul> </li> <li>• High Speed Mode                             <ul style="list-style-type: none"> <li>◦ ppm of Reading = 6000</li> <li>◦ ppm of Range = 104</li> </ul> </li> </ul>
Resistance Accuracy Verification	<p>Resistance = <math>20000 \times \frac{\text{Voltage}}{(2.5 - \text{Voltage})}</math></p> <p>TestLimits = Test Value ± <math>\frac{\text{Offset Error}(R_t, T, \text{Noise}, T_{\text{conv}})}{V_{\text{ref}}} \times \frac{(R_t + R_{\text{CJ\_ref}})^2}{R_{\text{CJ\_ref}}} \dots + \text{Gain Error}(T, T_{\text{conv}}) \times R_t \times \left(\frac{R_t + R_{\text{CJ\_ref}}}{R_{\text{CJ\_ref}}}\right) \times R_t \times R_{\text{CJ\_ref}}</math></p> <ul style="list-style-type: none"> <li>• <math>R_t</math> = Test value (resistance)</li> <li>• <math>R_{\text{CJ\_ref}}</math> = Reference resistance</li> </ul>

Equation Type	Equation
	<ul style="list-style-type: none"> <li>◦ Offset: <math>R_{CJ\_ref} = 1200 \Omega</math></li> <li>◦ Gain 1: <math>R_{CJ\_ref} = 20000 \Omega</math></li> <li>◦ Gain 2: <math>R_{CJ\_ref} = 80000 \Omega</math></li> <li>• <math>V_{ref}</math> = Reference voltage</li> <li>• T = Calibration temperature</li> <li>• <math>T_{conv}</math> = mode (high resolution (1 Hz) or high speed (100 Hz))</li> <li>• <math>R_{CJ\_err}(T)</math> = Reference error</li> </ul>

## TB-9214 Calibration Procedure

Calibrate the TB-9214 terminal block using Calibration Executive.

### Calibration Executive Procedure Features

Verify Only ✓	Verify & Adjust ✓	Manual Mode ✓	Optional Adjust ✗
---------------	-------------------	---------------	-------------------

### Approximate Test Time

15 minutes

### Test Equipment

The following table lists the test instruments required for calibrating the TB-9214.

**Table 32.** Test equipment for calibrating the TB-9214

Instrument	Recommended Model	Specification	Requirements
Thermocouple Calibrator	Ectron 1140A	TB-9214 Verification	If this instrument is unavailable, use a high precision thermocouple source with an accuracy of 0.08 °C or better and

Instrument		Recommended Model	Specification	Requirements
				an output impedance of $\approx 10 \Omega$ .
Barrier Strip Assembly	Thermocouple Wire	TT-E-24-SLE-100	TB-9214 Verification	E-type SLE 24 AWG, 20 to 30 meters
	Thermocouple Connector	Omega SMPW-E-M		E-type, must fit the output terminal of the thermocouple calibrator
	Thermocouple Barrier Strips	Omega BS16A		16 channels
	Thermocouple Barrier Strip Jackets (x16)	Omega BSJ-E		E-type, 16 channels
	Thermocouple Spade Lugs (x64)	Omega SLCH-20		32 lugs of chromel to match the E-type wires
		Omega SLCO-20		32 lugs of constantan to match the E-type wires
Spade-Lug Crimping Tool	Omega CRIMPING TOOL-P	Must effectively crimp the spade lugs with the 24 AWG wire		
Chassis		cDAQ-9178	All	—
C Series Module		NI 9214	—	Use a calibrated NI 9214

## Test Conditions

The following setup and environmental conditions are required to ensure the NI 9214 meets published specifications.

- Keep connections to the device as short as possible. Long cables and wires act as antennas, picking up extra noise that can affect measurements.
- Verify that all connections to the device are secure.
- Use shielded copper wire for all cable connections to the device. Use twisted-pairs wire to eliminate noise and thermal offsets.
- Maintain an ambient temperature of  $23\text{ }^{\circ}\text{C} \pm 5\text{ }^{\circ}\text{C}$ . The device temperature will be greater than the ambient temperature.
- Keep relative humidity below 80%.
- Allow a warm-up time of at least 15 minutes to ensure that the NI 9214 measurement circuitry is at a stable operating temperature.

## Device Setup

1. Make sure the cDAQ-9178 power source is not connected.
2. Attach a ring lug to a 14 AWG (1.6 mm) wire. Connect the ring lug to the ground terminal on the side of the cDAQ-9178 using the ground screw. Attach the other end of the wire to the system safety ground.
3. Install the NI 9214 in slot 8 of the cDAQ-9178 chassis. Leave slots 1 through 7 of the cDAQ-9178 chassis empty.



**Note** When multiple NI 9214 measurement devices are configured, you may have the option to calibrate multiple TB-9214 terminal blocks in a single session. Because only one measurement device can be configured as an instrument for the session, each terminal block must be connected to the selected measurement device during its calibration session.

4. Connect the cDAQ-9178 chassis to your host computer.
5. Connect the power source to the cDAQ-9178 chassis.
6. Launch Measurements & Automation Explorer (MAX).
7. Right-click the device name and select **Self-Test** to ensure that the device is working properly.

## Test Limit Equations

The following test limits are derived from the published specifications.

**Table 33.** TB- 9214 Test Limit Equations

Equation Type	Equation
Temperature Accuracy Verification	$\text{ErrorLimits} = \text{abs}(\text{Temp}_{\text{channel}} - \text{Temp}_{\text{CJ}})$ $\text{Temp}_{\text{error}}(\text{T}_{\text{TC}}, \text{T}_{\text{CJ}}) = \text{ErrorLimits}$ $\text{Temp}_{\text{error}}(\text{T}_{\text{TC}}, \text{T}_{\text{CJ}}) = T_E * [\text{V}_{\text{MEASURED}}(\text{T}_{\text{TC}}, \text{T}_{\text{CJ}}) + \text{V}_{\text{Error\_MODULE}}(\text{T}_{\text{TC}}) + \text{V}_E(\text{T}_{\text{CJ}} + \text{T}_{\text{CJ\_err}})] - \text{T}_{\text{TC}}$ <ul style="list-style-type: none"> <li>• <math>T_{\text{TC}}</math> = Thermocouple Temperature, 0 °C</li> <li>• <math>T_{\text{CJ}}</math> = Typical Cold Junction Temperature, 23 °C</li> <li>• <math>\text{V}_{\text{MEASURED}}(\text{T}_{\text{TC}}, \text{T}_{\text{CJ}}) = \text{V}_E(\text{T}_{\text{TC}}) - \text{V}_E(\text{T}_{\text{CJ}})</math></li> <li>• <math>\text{V}_{\text{Error\_MODULE}}(\text{T}_{\text{TC}}) = \text{Voltage Error Limit at } T_{\text{TC}}</math></li> <li>• <math>T_{\text{CJ\_err}}</math> = Temperate error range, <math>\pm 5</math> °C</li> </ul>

## NI 9215 Calibration Procedure

Calibrate the NI 9215 using Calibration Executive.

### Calibration Executive Procedure Features

Verify Only ✓	Verify & Adjust ✓	Manual Mode ✓	Optional Adjust ⓧ
---------------	-------------------	---------------	-------------------

### Approximate Test Time

15 minutes

### Test Equipment

The following table lists the test equipment required for calibrating NI 9215 modules.



**Table 312.** Test equipment for calibrating the NI 9215

Instrument	Recommended Model	Requirements
Calibrator	Fluke 5700A	If this instrument is unavailable, use a high-precision voltage source with an accuracy of at least 10 ppm and an output impedance of $\leq 50 \Omega$ .
Chassis	cDAQ-9178	—
Connection Accessory	NI 9932	Use with the NI 9215 with screw terminal.

## Test Conditions

The following setup and environmental conditions are required to ensure the NI 9215 meets published specifications.

- Keep connections to the device as short as possible. Long cables and wires act as antennas, picking up extra noise that can affect measurements.
- Use shielded copper wire for all cable connections to the device. Use twisted-pair wire to eliminate noise and thermal offsets.
- Maintain an ambient temperature of  $23 \text{ }^\circ\text{C} \pm 5 \text{ }^\circ\text{C}$ . The device temperature will be greater than the ambient temperature.
- Keep relative humidity below 80%.
- Allow a warm-up time of at least 10 minutes to ensure that the NI 9215 measurement circuitry is at a stable operating temperature.

## Device Setup

1. Install the NI 9215 in slot 8 of the cDAQ-9178 chassis. Leave slots 1 through 7 on the cDAQ-9178 chassis empty.
2. Configure the hardware using Measurement & Automation Explorer (MAX).
3. Launch the Calibration Executive procedure and complete the setup wizard.



**Note** If the NI 9215 module fails after calibration, return it to NI for repair or replacement.

## Test Limit Equations

The following test limits are derived from the published specifications found in the NI 9215 Calibration Procedure.

**Table 35.** NI 9215 Test Limit Equations

Equation Type	Equation
Accuracy	$\text{TestLimits} = \text{TestValue} \pm (\text{TestValue} * \% \text{ of Reading} + \text{Offset Error})$

### Related concepts:

- [Launching a Calibration Procedure](#)

## NI 9216/9226 Calibration Procedure

Calibrate the NI 9216/9226 using Calibration Executive.

### Calibration Executive Procedure Features

Verify Only ✓	Verify & Adjust ✓	Manual Mode ✓	Optional Adjust ✗
---------------	-------------------	---------------	-------------------

### Approximate Test Time

Verify Only	Verify & Adjust
15 minutes	45 minutes

### Test Equipment

The following table lists the test equipment required for calibrating NI 9216/9226 modules.

**Table 312.** Test equipment for calibrating the NI 9216/9226

Instrument	Recommended Model	Requirements
Calibrator	Fluke 5522A	Use a high-precision resistance source with gain accuracy $\leq 40$ ppm and offset error $\leq 2$ m $\Omega$ for the NI 9216, offset error $\leq 20$ m $\Omega$ for the NI 9226.
Chassis	cDAQ-9178	—

## Test Conditions

The following setup and environmental conditions are required to ensure the NI 9216/9226 meets published specifications.

- Keep connections to the device as short as possible. Long cables and wires act as antennas, picking up extra noise that can affect measurements.
- Verify that all connections to the device are secure.
- Use shielded copper wire for all cable connections to the device. Use twisted-pair wire to eliminate noise and thermal offsets.
- Maintain an ambient temperature of 20 °C to 28 °C. The device temperature will be greater than the ambient temperature.
- Keep relative humidity below 80%.
- Allow a warm-up time of at least 10 minutes to ensure that the NI 9216/9226 measurement circuitry is at a stable operating temperature.

## Device Setup

1. Make sure the cDAQ-9178 power source is not connected.
2. Attach a ring lug to a 14 AWG (1.6 mm) wire. Connect the ring lug to the ground terminal on the side of the cDAQ-9178 using the ground screw. Attach the other end of the wire to the system safety ground.
3. Install the NI 9216/9226 in slot 8 of the cDAQ-9178 chassis. Leave slots 1 through 7 of the chassis empty.
4. Connect the cDAQ-9178 chassis to your host computer.
5. Connect the power source to the cDAQ-9178 chassis.
6. Configure the hardware using Measurement & Automation Explorer (MAX).
7. Launch the Calibration Executive procedure and complete the setup wizard.



**Note** If the NI 9216/9226 module fails after calibration, return it to NI for repair or replacement.

## Test Limit Equations

The following test limits are derived from the published specifications found in the NI 9216/9226 Calibration Procedure.

**Table 37.** NI 9216/9226 Test Limit Equations

Equation Type	Equation
Accuracy	$\text{TestLimits} = \text{TestValue} \pm (\text{TestValue} * \text{GainError} + \text{Range} * \text{OffsetError} + \text{NoiseUncertainty})$

### Related concepts:

- [Launching a Calibration Procedure](#)

## NI 9217 Calibration Procedure

Calibrate the NI 9217 using Calibration Executive.

### Calibration Executive Procedure Features

Verify Only ✓	Verify & Adjust ✗	Manual Mode ✓	Optional Adjust ✗
---------------	-------------------	---------------	-------------------

### Approximate Test Time

20 minutes

### Test Equipment

The following table lists the test equipment required for calibrating NI 9217 modules.

**Table 312.** Test equipment for calibrating the NI 9217

Instrument	Recommended Model	Requirements
DMM	Agilent 3458A	If this instrument is unavailable, use a multiranging 7 1/2-digit DMM.
Precision Resistors	0 $\Omega$ , 100 $\Omega$ , 350 $\Omega$ *	You must use resistors that are <10 ppm/ $^{\circ}$ C or better.
Chassis	cDAQ-9178	—
Connection Accessory	NI 9939	16-pos strain relief and high voltage screw terminal.



**Note** \*These are approximate values. Use resistor values as close to 100  $\Omega$  and 350  $\Omega$  as possible. For the 0  $\Omega$  resistor, use a short piece of wire.

## Test Conditions

The following setup and environmental conditions are required to ensure the NI 9217 meets published specifications.

- Keep connections to the device as short as possible. Long cables and wires act as antennas, picking up extra noise that can affect measurements.
- Use shielded copper wire for all cable connections to the device. Use twisted-pair wire to eliminate noise and thermal offsets.
- Maintain an ambient temperature of 23  $^{\circ}$ C  $\pm$ 5  $^{\circ}$ C. The device temperature will be greater than the ambient temperature.
- Keep relative humidity below 80%.
- Allow a warm-up time of at least 10 minutes to ensure that the NI 9217 measurement circuitry is at a stable operating temperature.

## Device Setup

1. Install the NI 9217 in slot 8 of the cDAQ-9178 chassis. Leave slots 1 through 7 on the cDAQ-9178 chassis empty.
2. Configure the hardware using Measurement & Automation Explorer (MAX).
3. Launch the Calibration Executive procedure and complete the setup wizard.



**Note** If the NI 9217 module fails after calibration, return it to NI for repair or replacement.

## Test Limit Equations

The following test limits are derived from the published specifications found in the NI 9217 Calibration Procedure.

**Table 39.** NI 9217 Test Limit Equations

Equation Type	Equation
Accuracy	$\text{TestLimits} = \text{TestValue} \pm [\text{abs}(\text{DMM} - 100 \Omega) * 175 \text{ ppm} + 16 \text{ m}\Omega]$



**Note** The DMM value in the test limit equation must be read using a DMM with the accuracy requirements listed in the section.

### Related concepts:

- [Launching a Calibration Procedure](#)

## NI 9218 Calibration Procedure

Calibrate the NI 9218 using Calibration Executive.

### Calibration Executive Procedure Features

Verify Only ✓	Verify & Adjust ✓	Manual Mode ✓	Optional Adjust ✗
---------------	-------------------	---------------	-------------------

### Approximate Test Time

Verify Only	Verify & Adjust
32 minutes	103 minutes

## Test Equipment

The following table lists the test equipment required for calibrating NI 9218 modules.

**Table 312.** Test equipment for calibrating the NI 9218

Instrument	Recommended Model	Requirements
Calibrator	Fluke 5700A	Use a device that can source voltages as high as $\pm 50$ V and meets the following specifications: <ul style="list-style-type: none"> <li>• <math>\leq 100</math> ppm gain error</li> <li>• <math>\leq 3</math> <math>\mu</math>V offset error</li> <li>• <math>&lt; 3</math> <math>\mu</math>V offset at voltages less than 60 mV</li> <li>• <math>&lt; 200</math> mV offset at voltages less than 15 V</li> <li>• <math>&lt; 1</math> mV offset at voltages less than 60 V</li> </ul>
DMM (x2)	PXI-4071	Use a DMM with $< 40$ $\Omega$ of error at resistances $< 400$ k $\Omega$ .  For DMM1, use one DMM with $< 50$ ppm gain error, and $< 50$ $\mu$ V of offset error at voltages $< 3.5$ V.  For DMM2, use a second DMM with $< 50$ ppm gain error, and $< 2$ $\mu$ V of offset error at voltages $< 50$ mV.
Discrete Resistors	—	TCR: $< 25$ ppm/ $^{\circ}$ C  Resistor values: 10 k $\Omega$ (2x), 249 $\Omega$
cDAQ Chassis	cDAQ-9178	—
Measurement Adapters	NI 9982D (x4)*	Use for NI 9218 with DSUB connector.
	NI 9983D	Use for NI 9218 with DSUB connector.
	NI 9987D	Use for NI 9218 with DSUB connector.
	NI 9982L (x4)*	Use for NI 9218 with LEMO connector.
	NI 9983L	Use for NI 9218 with LEMO connector.
	NI 9987L	Use for NI 9218 with LEMO connector.



**Note** \*The Bridge Voltage step requires three different connections to the NI 9982. It is recommended that you use four separate NI 9982 measurement adapters, with three of these connections pre-configured for the bridge steps.

## Test Conditions

The following setup and environmental conditions are required to ensure the NI 9218 meets published specifications.

- Keep connections to the device as short as possible. Long cables and wires act as antennas, picking up extra noise that can affect measurements.
- Verify that all connections to the device are secure.
- Use shielded copper wire for all cable connections to the device. Use twisted-pair wire to eliminate noise and thermal offsets.
- Maintain an ambient temperature of 23 °C ±5 °C. The device temperature will be greater than the ambient temperature.
- Keep relative humidity below 80%.
- Allow a warm-up time of at least 10 minutes to ensure that the NI 9218 measurement circuitry is at a stable operating temperature.

## Device Setup

1. Install the NI 9218 in slot 8 of the cDAQ-9178 chassis. Leave slots 1 through 7 in chassis empty.
2. Connect the cDAQ-9178 chassis to your host computer.
3. Connect the power source to the cDAQ-9178 chassis.
4. Configure the hardware using Measurement & Automation Explorer (MAX).
5. Launch the Calibration Executive procedure and complete the setup wizard.

## Test Limit Equations

The test limits in this procedure are derived from the published specifications found in the NI 9218 Calibration Procedure.

$$\text{Limits} = \text{TestValue} \pm ((\text{TestValue} * \text{Gain Error}) + (\text{Offset Error}))$$

**Related concepts:**



- [Launching a Calibration Procedure](#)

## NI 9219 Calibration Procedure

Calibrate the NI 9219 using Calibration Executive.

### Calibration Executive Procedure Features

Verify Only ✓	Verify & Adjust ✓	Manual Mode ✗	Optional Adjust ✗
---------------	-------------------	---------------	-------------------

### Approximate Test Time

Verify Only	Verify & Adjust
50 minutes	150 minutes



**Note** Instruments can be used in manual mode, but the switch does not support being operated in manual mode.

### Test Equipment

The following table lists the test equipment required for calibrating NI 9219 modules.

**Table 312.** Test equipment for calibrating the NI 9219

Instrument	Recommended Model	Requirements
Calibrator	Fluke 5520	Voltage Mode <ul style="list-style-type: none"> <li>• Noise:               <ul style="list-style-type: none"> <li>◦ <math>\leq 5 \text{ mV}_{\text{pk-pk}}</math> 0.1 Hz–10 Hz at 48 V</li> <li>◦ <math>\leq 500 \text{ } \mu\text{V}_{\text{pk-pk}}</math> 0.1 Hz–10 Hz at 12 V</li> <li>◦ <math>\leq 500 \text{ } \mu\text{V}_{\text{pk-pk}}</math> 0.1 Hz–10 Hz at 3.2 V</li> <li>◦ <math>\leq 50 \text{ } \mu\text{V}_{\text{pk-pk}}</math> 0.1 Hz–10 Hz at 0.8 V</li> <li>◦ <math>\leq 5 \text{ } \mu\text{V}_{\text{pk-pk}}</math> 0.1 Hz–10 Hz at 0.1 V</li> </ul> </li> </ul> Current Mode

Instrument	Recommended Model	Requirements
		<ul style="list-style-type: none"> <li>Noise <math>\leq 500</math> nA<sub>pk-pk</sub> 0.1 Hz–10 Hz</li> </ul> <p>Resistance Mode</p> <ul style="list-style-type: none"> <li>Output resistance values between 0 <math>\Omega</math> and 10 k<math>\Omega</math> with <math>&lt; 0.25</math> <math>\Omega</math> resolution</li> </ul>
DMM (x2)	PXI-4071	<p>Voltage Accuracy</p> <p>DMM 1:</p> <ul style="list-style-type: none"> <li><math>\leq 30</math> ppm uncertainty and <math>\leq 0.8</math> <math>\mu</math>V offset error in smallest range</li> <li><math>\leq 15</math> ppm uncertainty for voltages under 3 V</li> </ul> <p>DMM 2:</p> <ul style="list-style-type: none"> <li><math>\leq 20</math> ppm for uncertainty voltages under 1 V and <math>\leq 0.8</math> <math>\mu</math>V offset error in smallest range</li> </ul> <p>Resistance Accuracy</p> <ul style="list-style-type: none"> <li><math>\leq 60</math> ppm uncertainty and <math>\leq 0.01</math> <math>\Omega</math> offset error in smallest range</li> </ul> <p>Current Accuracy</p> <ul style="list-style-type: none"> <li><math>\leq 270</math> ppm uncertainty for current, <math>\leq 2</math> nA offset error in smallest range</li> </ul>
cDAQ Chassis	cDAQ-9178	—

## Additional Equipment

The following table lists additional equipment that is required for the calibration fixture.

Equipment	Recommended Model	Requirements
Switch Matrix	PXI/PXIe-2737	Switch required for this fixture.

Equipment	Recommended Model	Requirements
MIO 63xx Model Device	PXIe-6341	8 Digital I/O lines capable of driving 24 mA of current each.
CAL-9219	P/N 785860-01	NI 9219 Calibration Fixture
Cable Assembly	SH37F-OM6/4 (P/N 146907-01)	9219 Calibration Cable Kit
Switch Cable	SH160DIN-SH160DIN (P/N 782417-02)	160-pin DIN to 160-pin DIN
Shielded Cable	SHC68-68-EPM (P/N 192061-01)	68-position D-type to 68-position VHDCI Offset, 1 m cable
Banana Cables (x10)	—	—

### Legacy Switch Fixture

Prior to version 4.5, Calibration Executive supported a legacy switch fixture. The new switch fixture is recommended; however, if you use the legacy switch fixture, the following equipment is required.

Equipment	Recommended Model	Requirements
Switch Matrix	PXI/PXIe-2529 (x2) and PXI-2503	Switches required for this fixture.
Switch Fixture	Custom Switch Fixture	Contact NI and reference NI P/N 539725A-025.
Banana Cables (x10)	—	—

### Test Conditions

The following setup and environmental conditions are required to ensure the NI 9219 meets published specifications.

- Use the switches and switch fixture provided by NI to calibrate the NI 9219 using Calibration Executive.
- Verify that all connections to the device are secure.
- Maintain an ambient temperature of 23 °C ±5 °C. The device temperature will be

greater than the ambient temperature.

- Keep relative humidity below 80%.
- Allow a warm-up time of at least 10 minutes to ensure that the NI 9219 measurement circuitry is at a stable operating temperature.

## Device Setup

1. Install the NI 9219 in slot 8 of the cDAQ-9178 chassis. Leave slots 1 through 7 in chassis empty.
2. Configure the hardware using Measurement & Automation Explorer (MAX).
3. Launch the Calibration Executive procedure and complete the setup wizard.
4. Connect the calibration fixture to the system. Refer to the appropriate setup instructions below, based on the fixture you are using.

## CAL-9219 Connection Setup

Complete the following steps before running the Calibration Executive procedure.

1. Connect the NI 2737 switch to the "Switch 2" connector on the fixture shown below using the 160-pin DIN cable.
2. Connect the NI 6341 device to the "Switch 1" connector using the SHC68-68-EPM cable.

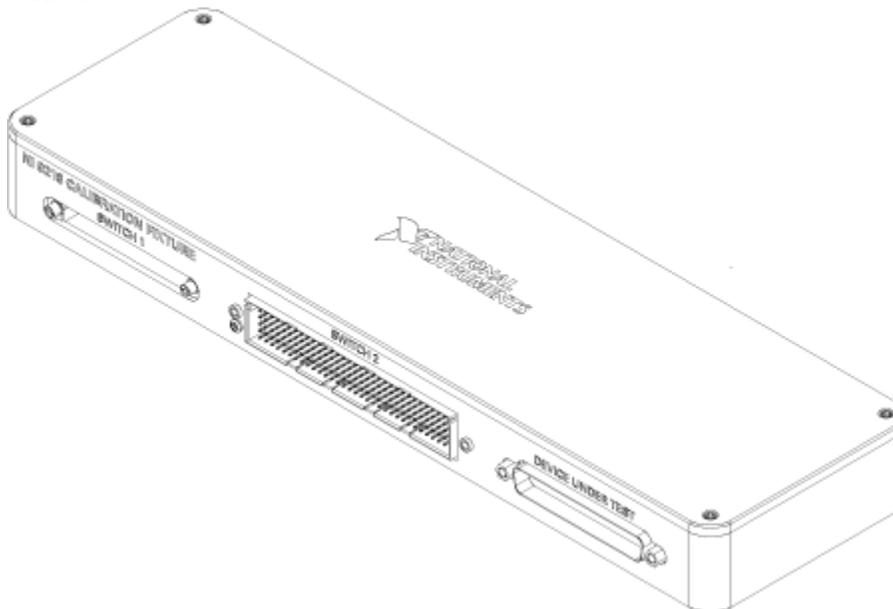

3. Connect the NI 9219 to the "Device Under Test" connector using the NI 9219 Fixture Cable. Refer to the labels on the cable to determine which channels on the NI 9219 to connect.

4. Connect the banana cables to the two DMMs and calibrator according to the associated labels on the CAL-9219 calibration fixture. Keep track of **DMM 1** and **DMM 2**; these need to match the configuration in Calibration Executive.

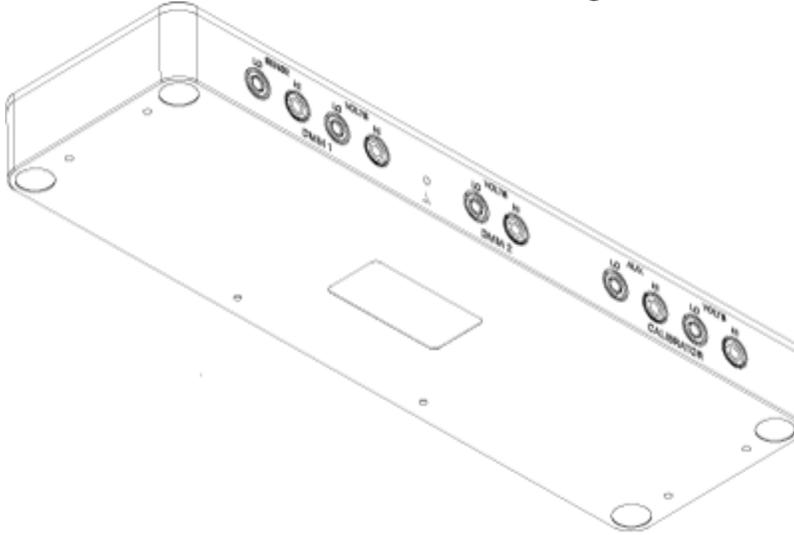

## Legacy Switch Fixture

Although NI recommends that you upgrade to the CAL-9219 fixture and PXIe-2737 switches, Calibration Executive still supports the legacy switch fixture. Complete the following steps to set up the legacy fixture.

1. Connect the two TB-2636 terminal blocks to the two NI 2529 switches. Make sure to note which switch is connected to TB1 and TB2; these must correlate with NI 2529 #1 and NI 2529 #2 when configuring the devices during setup.
2. Connect the TB-2605 (TB3) to the NI 2503.
3. Connect the banana cables to their respective instruments based on their labels. Banana connectors that share the same label should be stacked at the instrument. Be sure to configure the two DMMs correctly during setup.
4. Connect the four NI 9219 connectors to their respective channels on the NI 9219 under test.

## Switch Maintenance

To ensure proper operation of the switches used in this procedure, you must periodically test the performance of your switches.

If you use the recommended fixture with the NI 2737 switch matrix, you can use the NI

Switch Health Center periodically to confirm that the switch is continuing to operate as expected. The NI Switch Health Center can be found in program files, or you can right-click the NI 2737 switch device in NI-MAX to access the NI Switch Health Center.

If you use the legacy fixture with the NI 2737 switch matrix with the NI 2529 and PXI-2503 switches, refer to the ***NI 2503/2529 Switch Performance Test*** for instructions on validating the performance of the switches used in this procedure.



**Note** If the fixture used to connect the switches for the NI 9219 procedure is determined to be the cause of performance issues with this procedure, contact NI for support.

## Test Limit Equations

The test limits in this procedure are derived from the published specifications found in the ***NI 9219 Calibration Procedure***.

## Related concepts:

- [Launching a Calibration Procedure](#)
- [NI 2503/2529 Switch Performance Test](#)

## NI 2503/2529 Switch Performance Test

Test the performance of the PXI-2503 and PXI/PXIe-2529 using Calibration Executive.

## Calibration Executive Procedure Features

Verify only ✓	Verify & Adjust ✗	Manual Mode ✓	Optional Adjust ✗
---------------	-------------------	---------------	-------------------

## Approximate Test Time

Device	Performance Test
PXI-2503	3 minutes
PXI/PXIe-2529	8 minutes

## Test Equipment

The following table lists the test instruments required for testing the NI 2503/2529.

**Table 170.** Equipment for testing PXI-2503 and PXI/PXIe-2529 performance

Instrument	Recommended Model	Requirements
DMM	PXI-4071	Voltage Accuracy: 7.5 digits Resistance Accuracy: 6.5 digits
Terminal Block	PXI-2503: TB-2606 PXI/PXIe-2529: TB-2636	—

The switch performance tests should be executed periodically on switches used with Calibration Executive procedures to check if any switch paths have become damaged, or if the switches are approaching the end of their useful life. The frequency of execution of these tests will depend on many factors, including how often the switches are used.

## Test Conditions

The following setup and environmental conditions are required to ensure the NI 2503/2529 meets published specifications.

- Keep connections to the device as short as possible. Long cables and wires act as antennas, picking up extra noise that can affect measurements.
- Verify that all connections to the device are secure.
- Use shielded copper wire for all cable connections to the device. Use twisted-pair wire to eliminate noise and thermal offsets.
- Maintain an ambient temperature of  $23\text{ °C} \pm 5\text{ °C}$ . The device temperature will be greater than the ambient temperature.
- Keep relative humidity below 80%.

## Device Setup

1. Configure the hardware using Measurement & Automation Explorer (MAX).

2. Launch the Calibration Executive procedure and complete the setup wizard.
3. Complete the following steps to create fixtures that will be used to connect the switches to the DMM.

### Create the NI 2529 Fixture

1. On the TB-2636, connect the positive (+) and negative (-) terminals together for C0—C31.
2. Connect all + terminals together for R0 to R3, and wire them out using two separate wires to banana connectors labeled "DMM HI" and "DMM HI Sense".
3. Connect all - terminals together for R0 to R3, and wire them out using two separate wires to banana connectors labeled "DMM LO" and "DMM LO Sense".

To run the procedure, connect the TB-2636 to the PXI/PXIe-2529 switch, and connect the four banana connectors to the appropriate terminals on the DMM.

### Create the NI 2503 Fixture

1. On the TB-2606, connect the + and - terminals together for C0 to C5.
2. Connect all + terminals together for R0 to R3, and wire them out using two separate wires to banana connectors labeled "DMM HI" and "DMM HI Sense".
3. Connect all - terminals together for R0 to R3, and wire them out using two separate wires to banana connectors labeled "DMM LO" and "DMM LO Sense".

To run the procedure, connect the TB-2606 to the PXI-2503 switch, and connect the four banana connectors to the appropriate terminals on the DMM.

### Test Limit Equations

These switch tests are not intended to be a validation of the full warranted performance of these devices. The parameters and limits used in these tests are based on the needs of the procedures in Calibration Executive that use these switches to ensure they meet the performance requirements of those procedures.

#### Related concepts:

- [Launching a Calibration Procedure](#)



# NI 9220 Calibration Procedure

Calibrate the NI 9220 using Calibration Executive.

## Calibration Executive Procedure Features

Verify Only ✓	Verify & Adjust ✓	Manual Mode ✓	Optional Adjust ✗
---------------	-------------------	---------------	-------------------

## Approximate Test Time

Verify	Verify & Adjust
2 minutes	5 minutes

## Test Equipment

The following table lists the test equipment required for calibrating NI 9220 modules.

**Table 312.** Test equipment for calibrating the NI 9220

Instrument	Recommended Model	Requirements
Calibrator	Fluke 5700A	Use a high-precision voltage source with an accuracy of $\leq 15$ ppm and an output impedance of $\leq 50 \Omega$ .
Chassis	cDAQ-9178	—
DSUB Connection Accessory	NI 9923	—

## Test Conditions

The following setup and environmental conditions are required to ensure the NI 9220 meets published specifications.

- Keep connections to the device as short as possible. Long cables and wires act as antennas, picking up extra noise that can affect measurements.
- Verify that all connections to the NI 9220 are secure.
- Use shielded copper wire for all cable connections to the device. Use twisted-pairs

wire to eliminate noise and thermal offsets.

- Maintain an ambient temperature of  $23\text{ }^{\circ}\text{C} \pm 5\text{ }^{\circ}\text{C}$ .
- Keep relative humidity below 80%.
- Allow a warm-up time of at least 10 minutes to ensure that the NI 9220 measurement circuitry is at a stable operating temperature.

## Device Setup

1. Install the NI 9220 in slot 8 of the cDAQ-9178 chassis. Leave slots 1 through 7 on the cDAQ-9178 chassis empty.
2. Configure the hardware using Measurement & Automation Explorer (MAX).
3. Launch the Calibration Executive procedure and complete the setup wizard.

## Test Limit Equations

The following test limits are derived from the published specifications found in the NI 9220 Calibration Procedure.

**Table 44.** NI 9220 Test Limit Equations

Equation Type	Equation
Accuracy	$\text{TestLimits} = \text{TestValue} \pm (\text{TestValue} * \% \text{ of Reading} + \text{OffsetError})$

## Related concepts:

- [Launching a Calibration Procedure](#)

## NI 9222/9223 Calibration Procedure

Calibrate the NI 9222/9223 using Calibration Executive.

## Calibration Executive Procedure Features

Verify Only ✓	Verify & Adjust ✓	Manual Mode ✓	Optional Adjust ⓧ
---------------	-------------------	---------------	-------------------

## Approximate Test Time

15 minutes

## Test Equipment

The following table lists the test equipment required for calibrating NI 9222/9223 modules.

**Table 312.** Test equipment for calibrating the NI 9222/9223

Instrument	Recommended Model	Requirements
Calibrator	Fluke 5700A	High-precision voltage source with an accuracy of $\leq 15$ ppm and an output impedance of $\leq 50 \Omega$ .

## Test Conditions

The following setup and environmental conditions are required to ensure the NI 9222/9223 meets published specifications.

- Keep connections to the device as short as possible. Long cables and wires act as antennas, picking up extra noise that can affect measurements.
- Use shielded copper wire for all cable connections to the device. Use twisted-pairs wire to eliminate noise and thermal offsets.
- Verify that all connections to the device are secure.
- Maintain an ambient temperature of  $23 \text{ }^\circ\text{C} \pm 5 \text{ }^\circ\text{C}$ . The device temperature will be greater than the ambient temperature.
- Keep relative humidity below 80%.
- Allow a warm-up time of at least 10 minutes to ensure that the NI 9222/9223 measurement circuitry is at a stable operating temperature.

## Device Setup

1. Install the NI 9222/9223 in slot 8 of the cDAQ-9178 chassis. Leave slots 1 through 7 on the cDAQ-9178 chassis empty.
2. Configure the hardware using Measurement & Automation Explorer (MAX).
3. Launch the Calibration Executive procedure and complete the setup wizard.

## Test Limit Equations

The following test limits are derived from the published specifications found in the NI 9222/9223 Calibration Procedure.

**Table 46.** NI 9222/9223 Test Limit Equations

Equation Type	Equation
Accuracy	$\text{TestLimits} = \text{TestValue} \pm [\text{abs}(\text{TestValue}) * \text{GainError}(\%) + \text{Range} * \text{OffsetError}(\%)]$

### Related concepts:

- [Launching a Calibration Procedure](#)

## NI 9224/9228 Calibration Procedure

Calibrate the NI 9224/9228 using Calibration Executive.

### Calibration Executive Procedure Features

Verify Only ✓	Verify & Adjust ✓	Manual Mode ✓	Optional Adjust ✗
---------------	-------------------	---------------	-------------------

### Approximate Test Time

Warmup	Verify Only	Verify & Adjust
15 minutes	27 minutes	31 minutes

### Test Equipment

The following table lists the test equipment required for calibrating NI 9224/9228 modules.

**Table 312.** Test equipment for calibrating the NI 9224/9228

Instrument	Recommended Model	Requirements
Calibrator	Fluke 5502A	High-precision voltage source with gain error of $\leq 50$ ppm and offset error $< 50$ $\mu$ V.
Chassis	cDAQ-9178	—

## Test Conditions

The following setup and environmental conditions are required to ensure the NI 9224/9228 meets published specifications.

- Keep connections to the device as short as possible. Long cables and wires act as antennas, picking up extra noise that can affect measurements.
- Verify that all connections to the device are secure.
- Maintain an ambient temperature of  $23\text{ }^{\circ}\text{C} \pm 5\text{ }^{\circ}\text{C}$ . The device temperature will be greater than the ambient temperature.
- Keep relative humidity below 80%.
- Allow a warm-up time of at least 15 minutes to ensure that the device measurement circuitry is at a stable operating temperature.

## Device Setup

1. Make sure the cDAQ-9178 power source is not connected.
2. Connect the cDAQ-9178 to the system safety ground.
  - a. Attach a ring lug to a 14 AWG (1.6 mm) wire.
  - b. Connect the ring lug to the ground terminal on the side of the cDAQ-9178 using the ground screw.
  - c. Attach the other end of the wire to the system safety ground.
3. Install the NI 9224/9228 in slot 8 of the cDAQ-9178 chassis. Leave slots 1 through 7 of the chassis empty.
4. Connect the cDAQ-9178 chassis to your host computer
5. Connect the power source to the cDAQ-9178 chassis.
6. Launch Measurement & Automation Explorer (MAX).
7. Right-click the device name and select **Self-Test** to ensure that the device is working properly.

## Test Limit Equations

The following test limits are derived from the published specifications found in the NI 9224 or NI 9228 Calibration Procedure.

$$\text{TestLimit} = \text{TestValue} \pm ((\text{TestValue} \cdot \text{GainError}) + (\text{Range} \cdot \text{OffsetError}))$$

## NI 9225/9229/9239 Calibration Procedure

Calibrate the NI 9225/9229/9239 using Calibration Executive.

### Calibration Executive Procedure Features

Verify Only ✓	Verify & Adjust ✓	Manual Mode ✓	Optional Adjust ✗
---------------	-------------------	---------------	-------------------

### Approximate Test Time

30 minutes

<b>Verify Only</b>	<b>Verify &amp; Adjust</b>
5 minutes	12 minutes

### Test Equipment

The following table lists the test equipment required for calibrating NI 9225/9229/9239 modules.

**Table 312.** Test equipment for calibrating the NI 9225/9229/9239

Instrument	Recommended Model	Parameter Measured	Requirements
Calibrator	NI 9225: Fluke 5500A  NI 9229/9239: Fluke 5700A	Accuracy,  Adjustment	If this instrument is unavailable, use a high-precision voltage source with an accuracy of at least 10 ppm and an output impedance of $\leq 50 \Omega$ .

Instrument	Recommended Model	Parameter Measured	Requirements
Function Generator	NI 4461	Gain Matching, Phase Matching	If this instrument is unavailable, use a function generator capable of sourcing both 1 kHz and 20 kHz $\pm 10$ V <sub>pk</sub> AC sinusoidal signals with amplitude uncertainty of $\pm 10\%$ .
Chassis	cDAQ-9178	All	—

## Test Conditions

The following setup and environmental conditions are required to ensure the NI 9225/9229/9239 meets published specifications.

- Keep connections to the device as short as possible. Long cables and wires act as antennas, picking up extra noise that can affect measurements.
- Verify that all connections to the NI 9225/9229/9239 are secure.
- Use shielded copper wire for all cable connections to the device. Use twisted-pair wire to eliminate noise and thermal offsets.
- Maintain an ambient temperature of  $23\text{ }^{\circ}\text{C} \pm 5\text{ }^{\circ}\text{C}$ .
- Keep relative humidity below 80%.
- Allow a warm-up time of at least 10 minutes to ensure that the NI 9225/9229/9239 measurement circuitry is at a stable operating temperature.

## Device Setup

1. Install the NI 9225/9229/9239 in slot 8 of the cDAQ-9178 chassis. Leave slots 1 through 7 on the cDAQ-9178 chassis empty.
2. Configure the hardware using Measurement & Automation Explorer (MAX).
3. Launch the Calibration Executive procedure and complete the setup wizard.



**Note** If the NI 9225/9229/9239 module fails after calibration, return it to NI for repair or replacement.

## Test Limit Equations

The following test limits are derived from the published specifications found in the NI 9225, NI 9229, and NI 9239 Calibration Procedures.

**Table 49.** NI 9225 Test Limit Equations

Parameter Type	Parameter value
Accuracy	$\text{TestLimits} = \text{TestValue} \pm [\text{TestValue} * \text{GainError} (\% \text{ of Reading}) + \text{OffsetError}]$ <ul style="list-style-type: none"> <li>• Offset = 0.0523 mV</li> <li>• Gain = 0.066%</li> </ul>
Gain matching	±0.25 dB Max
Phase Matching (ch-to-ch)	0.035 Deg/kHz Max

**Table 50.** NI 9229 Test Limit Equations

Parameter Type	Parameter Value
Accuracy	$\text{TestLimits} = \text{TestValue} \pm [\text{TestValue} * \text{GainError} (\% \text{ of Reading}) + \text{OffsetError} (\text{mV})]$ <ul style="list-style-type: none"> <li>• Offset = 0.00766 V</li> <li>• Gain = 0.04%</li> </ul>
Gain Matching	±0.22 dB Max
Phase Matching (ch-to-ch)	0.045 Deg/kHz Max

**Table 51.** NI 9239 Test Limit Equations

Parameter Type	Parameter Value
Accuracy	$\text{TestLimits} = \text{TestValue} \pm [\text{TestValue} * \text{GainError} (\% \text{ of Reading}) + \text{OffsetError} (\text{mV})]$ <ul style="list-style-type: none"> <li>• Offset = 0.00135 V</li> <li>• Gain = 0.04%</li> </ul>
Gain Matching	±0.22 dB Max



Parameter Type	Parameter Value
Phase Matching (ch-to-ch)	0.075 Deg/kHz Max

### Related concepts:

- [Launching a Calibration Procedure](#)

## NI 9227 Calibration Procedure

Calibrate the NI 9227 using Calibration Executive.

### Calibration Executive Procedure Features

Verify Only ✓	Verify & Adjust ✓	Manual Mode ✓	Optional Adjust ⓧ
---------------	-------------------	---------------	-------------------

### Approximate Test Time

Verify Only	Verify & Adjust
3 minutes	8 minutes

### Test Equipment

The following table lists the test equipment required for calibrating NI 9227 modules.

**Table 312.** Test equipment for calibrating the NI 9227

Instrument	Recommended Model	Where Used	Requirements
Calibrator	Fluke 5520A	Accuracy, Adjustment	Use a high-precision current source with an accuracy $\leq 100$ ppm.
Function Generator	NI 5421	Gain Matching, Phase	Use a function generator with an output impedance of $50\Omega$ capable of sourcing both 1 kHz and 20 kHz $\pm 10$ V <sub>pk</sub> AC sinusoidal signals with amplitude uncertainty of $\pm 10\%$ to a $50\Omega$ load.

Instrument	Recommended Model	Where Used	Requirements
		Matching	
Termination Resistor	—	Gain Matching, Phase Matching	50 $\Omega$ , 1 W, $\pm 5\%$
Chassis	cDAQ-9178	All	—



**Note** To avoid an error, the NI 9227 calibration procedure requires that you set current limits of the calibrator to more than  $\pm 5$  Amps.

## Test Conditions

The following setup and environmental conditions are required to ensure the NI 9227 meets published specifications.

- Keep connections to the device as short as possible. Long cables and wires act as antennas, picking up extra noise that can affect measurements.
- Verify that all connections to the device are secure.
- Use shielded copper wire for all cable connections to the device. Use twisted-pairs wire to eliminate noise and thermal offsets.
- Maintain an ambient temperature of  $23\text{ }^{\circ}\text{C} \pm 5\text{ }^{\circ}\text{C}$ . The device temperature will be greater than the ambient temperature.
- Keep relative humidity below 80%.
- Allow a warm-up time of at least 10 minutes to ensure that the NI 9227 measurement circuitry is at a stable operating temperature.

## Device Setup

1. Make sure the cDAQ-9178 power source is not connected.
2. Connect the cDAQ-9178 to the system safety ground.
  - a. Attach a ring lug to a 14 AWG (1.6 mm) wire.

- b. Connect the ring lug to the ground terminal on the side of the cDAQ-9178 using the ground screw.
  - c. Attach the other end of the wire to the system safety ground.
3. Install the module in slot 8 of the cDAQ-9178 chassis. Leave slots 1 through 7 of the cDAQ-9178 chassis empty.
4. Connect the cDAQ-9178 chassis to your host computer.
5. Connect the power source to the cDAQ-9178 chassis.
6. Launch Measurement & Automation Explorer (MAX).
7. Right-click the device name and select **Self-Test** to ensure that the module is working properly.

## Test Limit Equations

The following test limits are derived from the published specifications.

**Table 53.** NI 9227 Test Limit Equations

Equation Type	Equation
Accuracy	$\text{TestLimits} = \text{TestValue} \pm (\text{TestValue} * \text{GainError} (\% \text{ of Reading}) + \text{OffsetError})$ <ul style="list-style-type: none"> <li>• Offset: 3.535mA</li> <li>• Gain: 0.1%</li> </ul>
Gain Matching	±0.13 dB Max
Phase Matching	±0.1 Deg/kHz Max

### Related concepts:

- [Set Current Limits](#)

## Set Current Limits

### Setting Current Output Limits on a Fluke 5520A/5522A Calibrator

Complete the following steps to set current output limits on the Fluke 5520A and Fluke 5522A calibrators.

1. Turn on the calibrator, and allow a warm-up period of at least 30 minutes.
2. Press the **RESET** key.
3. Press the **SETUP** key to open the Setup menu.
4. To display the Instrument Setup menu, press **INSTMT SETUP**.
5. To display the Output Setup menu, press **OUTPUT SETUP**.
6. To display the Set Limits menu, press **SET LIMITS**.
7. Press **CURRENT**.
8. Press **UPPER LIMIT**, type the new Upper Limit value, and then press the **ENTER** key.
9. Press **LOWER LIMIT**, type the new Lower Limit value, and then press the **ENTER** key.
10. Press the **PREV MENU** key several times until the message STORE CHANGES/ DISCARD CHANGES appears.
11. Press **STORE CHANGES**.
12. After the changes stored, press the **RESET** key.

## NI 9230/9232 Calibration Procedure

Calibrate the NI 9230/9232 using Calibration Executive.

### Calibration Executive Procedure Features

Verify Only ✓	Verify & Adjust ✓	Manual Mode ✓	Optional Adjust ✗
---------------	-------------------	---------------	-------------------

### Approximate Test Time

Module	Verify Only	Verify & Adjust
NI 9230/9232 (screw terminal)	3 minutes	7 minutes
NI 9230/9232 (BNC)	3 minutes	7 minutes

### Test Equipment

The following table lists the test equipment required for calibrating NI 9230/9232 modules.

**Table 312.** Test equipment for calibrating the NI 9230/9232

Instrument	Recommended Model	Parameter Measured	Requirements
Calibrator	Fluke 5700A	Accuracy, Adjustment	If this instrument is unavailable, use a high-precision voltage source with an accuracy $\leq 100$ ppm.
Chassis	cDAQ-9178	All	—

## Test Conditions

The following setup and environmental conditions are required to ensure the NI 9230/9232 meets published specifications.

- Keep connections to the device as short as possible. Long cables and wires act as antennas, picking up extra noise that can affect measurements.
- Verify that all connections to the device are secure.
- Use shielded copper wire for all cable connections to the device. Use twisted-pair wire to eliminate noise and thermal offsets.
- Maintain an ambient temperature of  $23\text{ }^{\circ}\text{C} \pm 5\text{ }^{\circ}\text{C}$ . The device temperature will be greater than the ambient temperature.
- Keep relative humidity below 80%.
- Allow a warm-up time of at least 10 minutes to ensure that the NI 9230/9232 measurement circuitry is at a stable operating temperature.

## Device Setup

1. Install the NI 9230/9232 in slot 8 of the cDAQ-9178 chassis. Leave slots 1 through 7 on the cDAQ-9178 chassis empty.
2. Configure the hardware using Measurement & Automation Explorer (MAX).
3. Launch the Calibration Executive procedure and complete the setup wizard.



**Note** If the NI 9230/9232 module fails after calibration, return it to NI for repair or replacement.

## Test Limit Equations

The following test limits are derived from the published specifications found in the NI 9230/9232 Calibration Procedure.

**Table 55.** NI 9230/9232 Test Limit Equations

Equation Type	Equation
Analog Voltage Accuracy	$\text{TestPointLevel} = \text{VoltageAccuracyLimit} = \text{TestValue} \pm ((\text{TestValue} * \text{GainPercent}) + (\text{Offset}))$ <ul style="list-style-type: none"> <li>Gain (% of reading) = 0.085%</li> <li>Offset (% of range) = 0.023%</li> </ul>

### Related concepts:

- [Launching a Calibration Procedure](#)

## NI 9231 Calibration Procedure

Calibrate the NI 9231 using Calibration Executive.

### Calibration Executive Procedure Features

Verify Only ✓	Verify & Adjust ✓	Manual Mode ✓	Optional Adjust ⓧ
---------------	-------------------	---------------	-------------------

### Approximate Test Time

Warmup	Verify Only	Verify & Adjust
10 minutes	5 minutes	14 minutes

### Test Equipment

The following table lists the test equipment required for calibrating NI 9231 modules.

**Table 312.** Test equipment for calibrating the NI 9231

Instrument	Recommended Model	Requirements
Chassis	cDAQ-9178	—
Calibrator	Fluke 5502A, 5522A, or 5730A	Use a high-precision voltage source with gain error of <100 ppm and offset error <0.1 mV
BNC (M) to Double Banana Adapter (M)	Pomona Electronics 1270	—
10-32 (M) to BNC (F) Coupler	10-32 Coaxial (M)-BNC Cable (NI part number 786657-01)	Characteristic impedance: 50 $\Omega$

## Test Conditions

The following setup and environmental conditions are required to ensure the NI 9231 meets published specifications.

- Keep connections to the device as short as possible. Long cables and wires act as antennas, picking up extra noise that can affect measurements.
- Verify that all connections to the device are secure.
- Maintain an ambient temperature of 23 °C  $\pm$ 5 °C. The device temperature will be greater than the ambient temperature.
- Keep relative humidity below 80%.
- Allow a warm-up time of at least 10 minutes to ensure that the device measurement circuitry is at a stable operating temperature.

## Device Setup

1. Make sure the cDAQ-9178 power source is not connected.
2. Connect the cDAQ-9178 to the system safety ground.
  - a. Attach a ring lug to a 14 AWG (1.6 mm) wire.
  - b. Connect the ring lug to the ground terminal on the side of the cDAQ-9178 using the ground screw.
  - c. Attach the other end of the wire to the system safety ground.
3. Install the module in slot 8 of the cDAQ-9178 chassis. Leave slots 1 through 7 of the cDAQ-9178 chassis empty.
4. Connect the cDAQ-9178 chassis to your host computer.
5. Connect the power source to the cDAQ-9178 chassis.

6. Launch Measurement & Automation Explorer (MAX).
7. Right-click the device name and select **Self-Test** to ensure that the module is working properly.

## Test Limit Equations

The following test limits are derived from the published specifications found in the NI 9231 Calibration Procedure.

**Table 57.** NI 9231 Test Limit Equations

Equation Type	Equation
Accuracy Verification Calculation	Test Limit = TestValue ± (TestValue * (Gain Error)/100 + Range * (Percent of Range)/100)

## NI 9234 Calibration Procedure

Calibrate the NI 9234 using Calibration Executive.

### Calibration Executive Procedure Features

Verify Only ✓	Verify & Adjust ✓	Manual Mode ✓	Optional Adjust ⓧ
---------------	-------------------	---------------	-------------------

### Approximate Test Time

30 minutes

### Test Equipment

The following table lists the test equipment required for calibrating NI 9234 modules.

**Table 312.** Test equipment for calibrating the NI 9234

Instrument	Recommended Model	Parameter Measured	Requirements
Calibrator	Fluke 5700A	Accuracy, Adjustment, Gain Matching	If this instrument is unavailable, use a high-precision voltage source with an accuracy ≤100 ppm.



Instrument	Recommended Model	Parameter Measured	Requirements
Function Generator	NI 4461	Phase Matching	If this instrument is unavailable, use a function generator capable of sourcing both 1 kHz and 10 kHz $\pm 4.5 V_{pk}$ AC sinusoidal signals with amplitude uncertainty of $\pm 10\%$ or less.
		CMRR	If this instrument is unavailable, use a function generator capable of sourcing 1 kHz $\pm 4.5 V_{pk}$ AC sinusoidal signals with amplitude uncertainty of $\pm 0.04$ dB or less.
		AC Coupling Response	If this instrument is unavailable, use a function generator capable of sourcing $\pm 0.5 V_{pk}$ AC sinusoidal signals from 1 Hz to 10 Hz with a gain over frequency flatness of $\pm 8$ mdB or less and a frequency uncertainty of $\pm 0.04$ dB or less.
DMM	NI 4070	IEPE Current IEPE Compliance Voltage	If this instrument is unavailable, use a DMM in current mode in the smallest range to measure 2 mA DC with a measurement uncertainty $\leq 0.5\%$ .
Source Measure Unit (SMU)	PXI-4132*	IEPE Compliance Voltage	If this instrument is unavailable, use an SMU capable of sourcing 20 V DC with an accuracy $\leq 0.1\%$ while sinking $> 2$ mA DC.
Chassis	cDAQ-9178	All	—
BNC Cable	—	All	Use a length appropriate for your application.



**Note** \*SMUs other than the PXI-4132 must be used in manual mode.

## Test Conditions

The following setup and environmental conditions are required to ensure the NI 9234 meets published specifications.

- Keep connections to the device as short as possible. Long cables and wires act as antennas, picking up extra noise that can affect measurements.

- Verify that all connections to the device are secure.
- Use shielded copper wire for all cable connections to the device. Use twisted-pair wire to eliminate noise and thermal offsets.
- Maintain an ambient temperature of  $23\text{ }^{\circ}\text{C} \pm 5\text{ }^{\circ}\text{C}$ . The device temperature will be greater than the ambient temperature.
- Keep relative humidity below 80%.
- Allow a warm-up time of at least 10 minutes to ensure that the NI 9234 measurement circuitry is at a stable operating temperature.

## Device Setup

1. Install the NI 9234 in slot 8 of the cDAQ-9178 chassis. Leave slots 1 through 7 on the cDAQ-9178 chassis empty.
2. Configure the hardware using Measurement & Automation Explorer (MAX).
3. Launch the Calibration Executive procedure and complete the setup wizard.



**Note** If the NI 9234 module fails after calibration, return it to NI for repair or replacement.

## Test Limit Equations

The following test limits are derived from the published specifications found in the NI 9234 Calibration Procedure.

**Table 59.** NI 9234 Test Limit Equations

Equation Type	Equation
Accuracy	$\text{TestLimits} = \text{TestValue} \pm [\text{TestValue} * \text{GainError} (\%) + \text{Range} * \text{OffsetError} (\%)]$
Channel to Channel Phase Matching	$\text{Phase Matching Limits (units of degrees)} = \pm((0.045 * \text{Test Frequency (kHz)}) + 0.04)$

Limits for the following tests are taken directly from the device specification datasheets, which have no derivations for the limits:

- Channel to Channel Gain Matching
- Channel Peak to Peak Flatness

- Common Mode Rejection Ratio
- IEPE Compliance Current
- IEPE Compliance Voltage

### Related concepts:

- [Launching a Calibration Procedure](#)

## NI 9235/9236 Calibration Procedure

Calibrate the NI 9235 and NI 9236 using Calibration Executive.

### Calibration Executive Procedure Features

Verify Only ✓	Verify & Adjust ✗	Manual Mode ✓	Optional Adjust ✗
---------------	-------------------	---------------	-------------------

### Approximate Test Time

40 minutes

### Test Equipment

The following table lists the test equipment required for calibrating NI 9235/9236 modules.

**Table 60.** Test equipment for calibrating the NI 9235/9236

Instrument	Recommended Model	Requirements
Calibrator	Fluke 5500A	<p>If this instrument is unavailable, use a calibrator with generation of resistances in the ranges of 108 <math>\Omega</math> to 132 <math>\Omega</math> and 315 <math>\Omega</math> to 385 <math>\Omega</math> with 0.01 <math>\Omega</math> resolution, an accuracy of at least 90 ppm, and automatic lead wire compensation.</p> <div style="border: 1px solid black; padding: 5px; margin-top: 10px;">  <p><b>Note</b> The Fluke 5700A and Fluke 5720A calibrator models cannot generate the resistances required to calibrate the NI 9235/9326.</p> </div>
DMM	NI 4070	If this instrument is unavailable, use a multi-ranging 6 1/2-digit DMM

Instrument	Recommended Model	Requirements
		with an accuracy of at least 40 ppm.
Chassis	cDAQ-9178	—
Connecting Wires	—	Connections between the module and the calibrator are insensitive to connection resistance except between the calibrator LO terminal and the module RC terminal. The resistance of this connection must be less than 200 mΩ to limit bridge linearity errors. The measurement accuracy verification TestLimits assume this requirement is met.

## Test Conditions

The following setup and environmental conditions are required to ensure the NI 9235/9236 meets published specifications.

- Keep connections to the device as short as possible. Long cables and wires act as antennas, picking up extra noise that can affect measurements.
- Use shielded copper wire for all cable connections to the device. Use twisted-pair wire to eliminate noise and thermal offsets.
- Maintain an ambient temperature of 23 °C ±5 °C. The device temperature will be greater than the ambient temperature.
- Keep relative humidity below 80%.
- Allow a warm-up time of at least 10 minutes to ensure that the NI 9235/9236 measurement circuitry is at a stable operating temperature.

## Device Setup

1. Install the NI 9235/9236 in slot 8 of the cDAQ-9178 chassis. Leave slots 1 through 7 on the cDAQ-9178 chassis empty.
2. Configure the hardware using Measurement & Automation Explorer (MAX).
3. Launch the Calibration Executive procedure and complete the setup wizard. Refer to NI 9235/9236 Calibration Setup for detailed connection instructions.



**Note** If the NI 9235/9236 module fails after calibration, return it to NI for repair or replacement.

## Test Limit Equations

The following test limits are derived from the published specifications found in the NI 9235/9236 Calibration Procedure.

**Table 61.** NI 9235/9236 Test Limit Equations

Equation Types	Equation
Accuracy	$\text{TestLimits} = \text{NominalValue} \pm \text{AbsoluteAccuracy}$ <ul style="list-style-type: none"> <li> <math display="block">\text{AbsoluteAccuracy} = \text{NominalValue} * \text{GainError} + \text{Range} * \text{OffsetError}</math> </li> </ul>

### Related concepts:

- [Launching a Calibration Procedure](#)
- [NI 9235/9236 Calibration Setup](#)

## NI 9235/9236 Calibration Setup

Set up the NI 9235/9236 for calibration.

### Connecting the Calibrator to the NI 9235/9236

Complete the following steps to connect the calibrator to the NI 9235 and NI 9236.

1. Set the calibrator to standby mode (STBY).
2. Connect the AUX HI terminal of the calibrator to the EXC1 terminal of the module.
3. Connect the HI terminal of the calibrator to the EXC0 terminal of the module.



**Note** You do not have to change the EXC terminal connections for each channel you verify, because the EXC terminals all connect to a common excitation supply inside the NI 9235/9236.



**Caution** The following three connections to the calibrator LO terminal must be connected at the calibrator LO output jack using discrete connections. Do

not short the AI and RC terminals at the module connector or on the connection wires.

1. Connect the LO terminal of the calibrator to the AUX LO terminal of the calibrator.
2. Connect the LO terminal of the calibrator to the AI terminal of the module channel you want to verify.
3. Connect the LO terminal of the calibrator to the RC terminal of the module channel you want to verify using the calibrator LO terminal to the NI 9235/9236 RC terminal connection wire.

The following figure shows how to connect the calibrator to the NI 9235/9236.

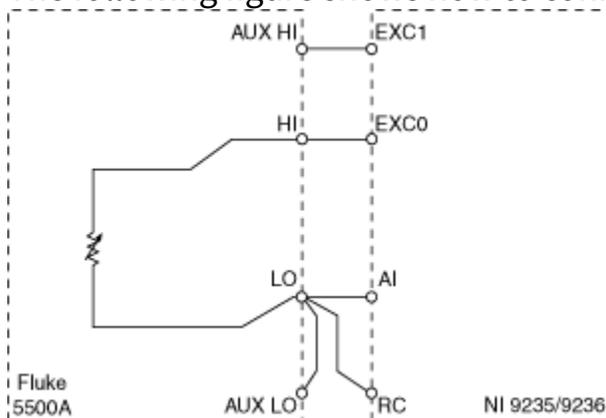

**Note** Ensure that the connection resistance between the calibrator LO terminal and the module RC terminal meets the requirement listed in NI 9235/9236 Test Equipment table.

## Calculating the Wire Resistance

Complete the following steps to calculate the resistance of the calibrator LO terminal to the NI 9235/9236 RC terminal connection wire.

1. Connect the LO terminal to RC terminal connection wire to the DMM as shown in the following figure.

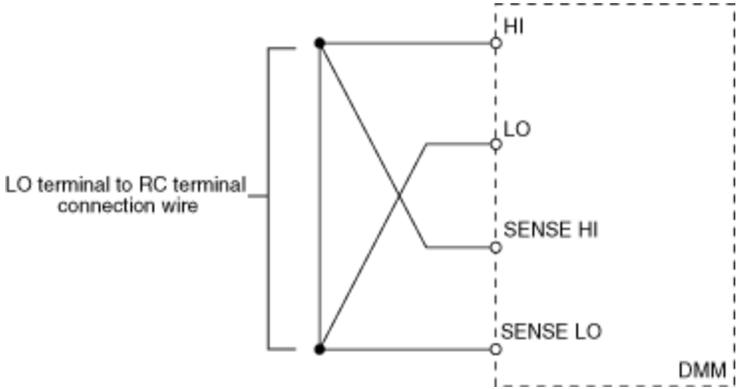

2. Take a 4-wire resistance measurement with the DMM and record the measurement.
3. Remove the LO terminal to RC terminal connection wire from the DMM.

**Related concepts:**

- [NI 9235/9236 Calibration Procedure](#)

## NI 9237 Calibration Procedure

Calibrate the NI 9237 using Calibration Executive.

### Calibration Executive Procedure Features

Verify Only ✓	Verify & Adjust ✗	Manual Mode ✓	Optional Adjust ✗
---------------	-------------------	---------------	-------------------

### Approximate Test Time

6 minutes

### Test Equipment

The following table lists the test equipment required for calibrating NI 9237 modules.

**Table 312.** Test equipment for calibrating the NI 9237

Instrument	Recommended Model	Requirements
Calibrator	Fluke 5700A	If this instrument is unavailable, use a high-precision voltage source with an accuracy of at least 10 ppm and an output impedance of $\leq 50 \Omega$ .

Instrument	Recommended Model	Requirements
DMM	NI 4070	If this instrument is unavailable, use a multiranging 6 1/2-digit DMM with an accuracy of at least 40 ppm.
Chassis	cDAQ-9178	—
Cable	RJ-50 cable	—
Bridge Completion Accessories	NI 9949, 350 $\Omega$ resistors	Use one NI 9949 screw terminal accessory and two 350 $\Omega$ resistors with at least 1% tolerance.

## Test Conditions

The following setup and environmental conditions are required to ensure the NI 9237 meets published specifications.

- Keep connections to the device as short as possible. Long cables and wires act as antennas, picking up extra noise that can affect measurements.
- Use shielded copper wire for all cable connections to the device. Use twisted-pair wire to eliminate noise and thermal offsets.
- Maintain an ambient temperature of 23 °C  $\pm$ 5 °C. The device temperature will be greater than the ambient temperature.
- Keep relative humidity below 80%.
- Allow a warm-up time of at least 10 minutes to ensure that the NI 9237 measurement circuitry is at a stable operating temperature.

## Device Setup

1. Install the NI 9237 in slot 8 of the cDAQ-9178 chassis. Leave slots 1 through 7 on the cDAQ-9178 chassis empty.
2. Configure the hardware using Measurement & Automation Explorer (MAX).
3. Launch the Calibration Executive procedure and complete the setup wizard.



**Note** If the NI 9237 module fails after calibration, return it to NI for repair or replacement.



## Test Limit Equations

The following test limits are derived from the published specifications found in the NI 9237 Calibration Procedure.

**Table 63.** NI 9237 Test Limit Equations

Equation Type	Equation
Accuracy	$\text{TestLimits} = \text{TestValue} \pm (\text{TestValue} * \text{GainError} + \text{OffsetError})$

### Related concepts:

- [Launching a Calibration Procedure](#)

## NI 9238 Calibration Procedure

Calibrate the NI 9238 using Calibration Executive.

### Calibration Executive Procedure Features:

Verify Only ✓	Verify & Adjust ✓	Manual Mode ✗	Optional Adjust ✗
---------------	-------------------	---------------	-------------------

### Approximate Test Time

Warm-up	Verify & Adjust
10 minutes	6 minutes

## Test Equipment

The following table lists the test equipment required for calibrating NI 9238 modules.

**Table 312.** Test equipment for calibrating the NI 9238

Instrument	Recommended Model	Requirements
Calibrator	Fluke 5500A	If this instrument is unavailable, use a high-precision voltage source with an accuracy of $\leq 60$ ppm and offset error $\leq 6$ $\mu\text{V}$ .

Instrument	Recommended Model	Requirements
Chassis	cDAQ-9178	—

## Test Conditions

The following setup and environmental conditions are required to ensure the NI 9238 meets published specifications.

- Keep connections to the device as short as possible. Long cables and wires act as antennas, picking up extra noise that can affect measurements.
- Use shielded copper wire for all cable connections to the device. Use twisted-pair wire to eliminate noise and thermal offsets.
- Maintain an ambient temperature of  $23\text{ °C} \pm 5\text{ °C}$ . The device temperature will be greater than the ambient temperature.
- Keep relative humidity below 80%.
- Allow a warm-up time of at least 10 minutes to ensure that the NI 9238 measurement circuitry is at a stable operating temperature.

## Device Setup

1. Install the NI 9238 in slot 8 of the cDAQ-9178 chassis. Leave slots 1 through 7 on the cDAQ-9178 chassis empty.
2. Configure the hardware using Measurement & Automation Explorer (MAX).
3. Launch the Calibration Executive procedure and complete the setup wizard.



**Note** If the NI 9238 module fails after calibration, return it to NI for repair or replacement.

## Test Limit Equations

The following test limits are derived from the published specifications found in the NI 9238 Calibration Procedure.

**Table 65.** NI 9238 Test Limit Equations

Equation Types	Equation
Accuracy Verification	$\text{AccuracyVerificationLimit} = \text{TestValue} \pm (\text{TestValue} * \text{GainError} + \text{Range} * \text{Offset Error})$

**Related concepts:**

- [Launching a Calibration Procedure](#)

## NI 9242/9244 Calibration Procedure

Calibrate the NI 9242/9244 using Calibration Executive.



**Hazardous Voltage** This procedure uses high voltage output from the calibrator. Once the procedure has started, ensure that the calibrator is in standby before adjusting connections. If necessary, manually set the calibrator to standby for connection adjustment.

### Calibration Executive Procedure Features

Verify Only ✓	Verify & Adjust ✓	Manual Mode ✓	Optional Adjust ⓧ
---------------	-------------------	---------------	-------------------

### Approximate Test Time

<10 minutes

### Test Equipment

The following table lists the test equipment required for calibrating NI 9242/9244 modules.

**Table 312.** Test equipment for calibrating the NI 9242/9244

Instrument	Recommended Model	Requirements
Calibrator	Fluke 5700A	If this instrument is unavailable, use a high-precision voltage source with an accuracy $\leq 57$ ppm and offset error $< 2$ mV and the

Instrument	Recommended Model	Requirements
		appropriate voltage range (450 V for NI 9242, 950 V for NI 9244).
Connector Backshell	NI 9967	Use the NI 9967 to ensure circuits connected to the NI 9242 are properly insulated from human contact.
	NI 9969	Use the NI 9969 to ensure circuits connected to the NI 9244 are properly insulated from human contact.
Chassis	cDAQ-9178	—

## Test Conditions

The following setup and environmental conditions are required to ensure the NI 9242/9244 meets published specifications.

- Keep connections to the device as short as possible. Long cables and wires act as antennas, picking up extra noise that can affect measurements.
- Verify that all connections to the device are secure.
- Use shielded copper wire for all cable connections to the device. Use twisted-pair wire to eliminate noise and thermal offsets.
- Maintain an ambient temperature of  $23\text{ °C} \pm 5\text{ °C}$ . The device temperature will be greater than the ambient temperature.
- Keep relative humidity below 80%.
- Allow a warm-up time of at least 10 minutes to ensure that the NI 9242/9244 measurement circuitry is at a stable operating temperature.

## Device Setup

1. Make sure the cDAQ-9178 power source is not connected.
2. Connect the cDAQ-9178 to the system safety ground.
  - a. Attach a ring lug to a 14 AWG (1.6 mm) wire.
  - b. Connect the ring lug to the ground terminal on the side of the cDAQ-9178 using the ground screw.
  - c. Attach the other end of the wire to the system safety ground.
3. Install the module in slot 8 of the cDAQ-9178 chassis. Leave slots 1 through 7 of the cDAQ-9178 chassis empty.
4. Connect the cDAQ-9178 chassis to your host computer.

5. Connect the power source to the cDAQ-9178 chassis.
6. Launch Measurement & Automation Explorer (MAX).
7. Right-click the device name and select **Self-Test** to ensure that the module is working properly.

## Test Limit Equations

The following test limits are derived from the published specifications found in the NI 9242/9244 Calibration Procedure.

**Table 67.** NI 9242 Test Limit Equations

Equation Type	Equation
Analog Voltage Input Verification	$\text{Absolute Voltage Accuracy} = \text{Reading} * (\text{GainError}) + \text{Range} * (\text{OffsetError})$ <ul style="list-style-type: none"> <li>• Range = 354 V (250 V<sub>rms</sub>)</li> <li>• Gain Error (% of Output) = 0.103%</li> <li>• Offset Error (% of Range) = 0.023%</li> <li>• Limits = Test Value ± Absolute Accuracy</li> </ul>

**Table 68.** NI 9244 Test Limit Equations

Equation Type	Equation
Analog Voltage Input Verification	$\text{Absolute Voltage Accuracy} = \text{Reading} * (\text{GainError}) + \text{Range} * (\text{OffsetError})$ <ul style="list-style-type: none"> <li>• Range = 565.7 V (400 V<sub>rms</sub>)</li> <li>• Gain Error (% of Output) = 0.089%</li> <li>• Offset Error (% of Range) = 0.010%</li> <li>• Limits = Test Value ± Absolute Accuracy</li> </ul>

## NI 9246/9247 Calibration Procedure

Calibrate the NI 9246/9247 using Calibration Executive.

## Calibration Executive Procedure Features

Verify Only ✓	Verify & Adjust ✓	Manual Mode ✓	Optional Adjust ⓧ
---------------	-------------------	---------------	-------------------

## Approximate Test Time

Verify Only	Verify & Adjust
4 minutes	8 minutes

## Test Equipment

The following table lists the test equipment required for calibrating NI 9246/9247 modules.

**Table 312.** Test equipment for calibrating the NI 9246/9247

Instrument	Recommended Model	Where Used	Requirements
Calibrator	Fluke 5522A	Accuracy, Adjustment	Use a high-precision current source with an accuracy $\leq 650$ ppm.
Chassis	cDAQ-9178	All	—

## Test Conditions

The following setup and environmental conditions are required to ensure the NI 9242/9244 meets published specifications.

- Keep connections to the device as short as possible. Long cables and wires act as antennas, picking up extra noise that can affect measurements.
- Verify that all connections to the device are secure.
- Use shielded copper wire for all cable connections to the device. Use twisted-pair wire to eliminate noise and thermal offsets.
- Maintain an ambient temperature of  $23\text{ }^{\circ}\text{C} \pm 5\text{ }^{\circ}\text{C}$ . The device temperature will be greater than the ambient temperature.
- Keep relative humidity below 80%.
- Allow a warm-up time of at least 10 minutes to ensure that the NI 9246/9247 measurement circuitry is at a stable operating temperature.

## Device Setup

1. Make sure the cDAQ-9178 power source is not connected.
2. Connect the cDAQ-9178 to the system safety ground.
  - a. Attach a ring lug to a 14 AWG (1.6 mm) wire.
  - b. Connect the ring lug to the ground terminal on the side of the cDAQ-9178 using the ground screw.
  - c. Attach the other end of the wire to the system safety ground.
3. Install the module in slot 8 of the cDAQ-9178 chassis. Leave slots 1 through 7 of the cDAQ-9178 chassis empty.
4. Connect the cDAQ-9178 chassis to your host computer.
5. Connect the power source to the cDAQ-9178 chassis.
6. Launch Measurement & Automation Explorer (MAX).
7. Right-click the device name and select **Self-Test** to ensure that the module is working properly.

## Test Limit Equations

The following test limit equation is derived from the published specifications found in the NI 9246/9247 Calibration Procedure.

$$\text{TestLimit} = \text{TestValue} \pm (\text{TestValue} \times \text{GainError} (\%) + \text{OffsetError})$$

## NI 9250/9251 Calibration Procedure

Calibrate the NI 9250/9251 using Calibration Executive.

### Calibration Executive Procedure Features

Verify Only ✓	Verify & Adjust ✓	Manual Mode ✓	Optional Adjust ✗
---------------	-------------------	---------------	-------------------

### Approximate Test Time

Verify Only	Verify & Adjust
3 minutes	5 minutes

## Test Equipment

The following table lists the test equipment required for calibrating NI 9250/9251 modules.

**Table 312.** Test equipment for calibrating the NI 9250/9251

Instrument	Recommended Model	Requirements
Calibrator	Fluke 5502A, Fluke 5522A, Fluke 5730A	Use a high-precision voltage source with gain error of <100 ppm and offset error <0.1 mV.
Chassis	cDAQ-9178	—
BNC (F) to Banana Adapter	Pomona Electronics 1269	—
BNC (M) to BNC (M) Coupler	Pomona Electronics 3533	Characteristic impedance: 50 $\Omega$
BNC F-F-F-T-Connector	Pomona Electronics 3284	Characteristic impedance: 50 $\Omega$
BNC (M) to BNC (M) Cable (x2)*	Pomona Electronics 2249	Characteristic impedance: 50 $\Omega$
mXLR to BNC (M) Cable (x2) <sup>†</sup>	NI 156789-XX or NI 140150-XX  0R46 (0.46 m)  0R91 (0.91 m)  2R4 (2.4 m)	—



### Note

- \*BNC (M) to BNC (M) cables (x2) are required only for the NI 9250.
- <sup>†</sup>mXLR to BNC (M) cables (x2) are required only for the NI 9251.



## Test Conditions

The following setup and environmental conditions are required to ensure the NI 9250/9251 meets published specifications.

- Keep connections to the device as short as possible. Long cables and wires act as antennas, picking up extra noise that can affect measurements.
- Verify that all connections to the device are secure.
- Use shielded copper wire for all cable connections to the device. Use twisted-pair wire to eliminate noise and thermal offsets.
- Maintain an ambient temperature of 23 °C ±5 °C. The device temperature will be greater than the ambient temperature.
- Keep relative humidity below 80%.
- Allow a warm-up time of at least 10 minutes to ensure that the device measurement circuitry is at a stable operating temperature.

## Device Setup

1. Make sure the cDAQ-9178 power source is not connected.
2. Connect the cDAQ-9178 to the system safety ground.
  - a. Attach a ring lug to a 14 AWG (1.6 mm) wire.
  - b. Connect the ring lug to the ground terminal on the side of the cDAQ-9178 using the ground screw.
  - c. Attach the other end of the wire to the system safety ground.
3. Install the module in slot 8 of the cDAQ-9178 chassis. Leave slots 1 through 7 of the cDAQ-9178 chassis empty.
4. Connect the cDAQ-9178 chassis to your host computer.
5. Connect the power source to the cDAQ-9178 chassis.
6. Launch Measurement & Automation Explorer (MAX).
7. Right-click the device name and select **Self-Test** to ensure that the module is working properly.

## Test Limit Equations

The following test limit equation is derived from the published specifications found in the NI 9250 Calibration Procedure and the NI 9251 Calibration Procedure.

$$\text{TestLimit} = \text{TestValue} \pm (\text{TestValue} \times \text{GainError} (\%) + \text{Range} \times \text{Percent of Range} (\%))$$

# NI 9252 Calibration Procedure

Calibrate the NI 9252 (DSUB or screw terminal) using Calibration Executive.

## Calibration Executive Procedure Features

Verify Only ✓	Verify & Adjust ✓	Manual Mode ✓	Optional Adjust ✗
---------------	-------------------	---------------	-------------------

## Approximate Test Time

Verify Only	Verify & Adjust
4 minutes	8 minutes

## Test Equipment

The following table lists the test equipment required for calibrating NI 9252 modules.

**Table 312.** Test equipment for calibrating the NI 9252

Instrument	Recommended Model	Requirements
Calibrator	Fluke 5502A	Use a high-precision DC voltage source with a gain uncertainty of <57 ppm and an offset uncertainty of <0.6 mV.
Chassis	cDAQ-9178	—
Terminal Block*	NI 9923	—



**Note** \* The NI 9923 terminal block is used only for the DSUB variant.

## Test Conditions

The following setup and environmental conditions are required to ensure the NI 9252 meets published specifications.

- Keep connections to the device as short as possible. Long cables and wires act as antennas, picking up extra noise that can affect measurements.

- Verify that all connections to the device are secure.
- Use shielded copper wire for all cable connections to the device. Use twisted-pair wire to eliminate noise and thermal offsets.
- Maintain an ambient temperature of 23 °C ±5 °C. The device temperature will be greater than the ambient temperature.
- Keep relative humidity below 80%.
- Allow a warm-up time of at least 10 minutes to ensure that the device measurement circuitry is at a stable operating temperature.

## Device Setup

1. Make sure the cDAQ-9178 power source is not connected.
2. Connect the cDAQ-9178 to the system safety ground.
  - a. Attach a ring lug to a 14 AWG (1.6 mm) wire.
  - b. Connect the ring lug to the ground terminal on the side of the cDAQ-9178 using the ground screw.
  - c. Attach the other end of the wire to the system safety ground.
3. Install the module in slot 8 of the cDAQ-9178 chassis. Leave slots 1 through 7 of the chassis empty.
4. Connect the cDAQ-9178 chassis to your host computer.
5. Connect the power source to the cDAQ-9178 chassis.
6. Launch Measurement & Automation Explorer (MAX).
7. Right-click the device name and select **Self-Test** to ensure that the module is working properly.

When using Fluke 55xx calibrators, the earth ground option is enabled by software during execution. If you use a 57xx calibrator with this procedure, make sure that the external ground is connected to the guard connector.

## Test Limit Equations

The following test limit equation is derived from the published specifications found in the NI 9252 Calibration Procedure.

$$\text{TestLimit} = \text{TestValue} \pm (\text{TestValue} \times \text{GainError} (\%) + \text{Range} \times \text{Percent of Range} (\%))$$

# NI 9260 Calibration Procedure

Calibrate the NI 9260 using Calibration Executive.

## Calibration Executive Procedure Features

Verify Only ✓	Verify & Adjust ✓	Manual Mode ✓	Optional Adjust ✗
---------------	-------------------	---------------	-------------------

## Approximate Test Time

13 minutes

## Test Equipment

The following table lists the test equipment required for calibrating NI 9260.

**Table 312.** Test equipment for calibrating the NI 9260

Instrument	Recommended Model	Requirements
DMM	PXI-4070	If this instrument is unavailable, use a multiranging 6 1/2-digit DMM with an accuracy of at least $\pm 40$ ppm.
Chassis	cDAQ-9178	—

## Test Conditions

The following setup and environmental conditions are required to ensure the NI 9260 meets published specifications.

- Keep connections to the device as short as possible. Long cables and wires act as antennas, picking up extra noise that can affect measurements.
- Use shielded copper wire for all cable connections to the device. Use twisted-pair wire to eliminate noise and thermal offsets.
- Verify that all connections to the module are secure.
- Maintain an ambient temperature of  $23\text{ °C} \pm 5\text{ °C}$ . The device temperature will be greater than the ambient temperature.
- Keep relative humidity below 80%.

- Allow a warm-up time of at least 10 minutes to ensure that the NI 9260 measurement circuitry is at a stable operating temperature.

## Device Setup

1. Install the NI 9260 module in slot 8 of the cDAQ-9178 chassis. Leave slots 1 through 7 of the chassis empty.
2. Configure the hardware using Measurement & Automation Explorer (MAX).
3. Launch the Calibration Executive procedure and complete the setup wizard.



**Note** If the NI module fails after calibration, return it to NI for repair or replacement.

## Test Limit Equations

The following test limits are derived from the published specifications found in the NI 9260 Calibration Procedure.

**Table 73.** NI 9260 Test Limit Equations

Equation Type	Equation
Voltage Accuracy Verification	$\text{TestLimit} = \text{TestValue} \pm (\text{TestValue} * (\text{GainError} / 100) + (\text{FS} * (\text{OffsetError} / 100)))$

## Related concepts:

- [Launching a Calibration Procedure](#)

## NI 9262/9263/9264/9265 Calibration Procedure

Calibrate the NI 9262/9263/9264/9265 using Calibration Executive.

## Calibration Executive Procedure Features

Verify Only ✓	Verify & Adjust ✓	Manual Mode ✓	Optional Adjust ✗
---------------	-------------------	---------------	-------------------

## Approximate Test Time

Device	Verify Only	Verify & Adjust
NI 9262/9263/9265	10 minutes	30 minutes
NI 9264	20 minutes	60 minutes

## Test Equipment

The following table lists the test equipment required for calibrating NI 9262/9263/9264/9265 modules.

**Table 312.** Test equipment for calibrating the NI 9262/9263/9264/9265

Instrument	Recommended Model	Requirements
DMM	NI 4070 (for use with NI 9263/9264/9265 modules)	If the NI 4070 is unavailable, use a multiranging 6 1/2-digit DMM with an accuracy of at least 40 ppm.
	NI 4081 (for use with NI 9262 module)	For the NI 9262, the DMM must have a 10 V range with $\leq 12$ ppm gain error.
Chassis	cDAQ-9178	—
Connection Accessory	NI 9932	Use for NI 9263. Backshell with 10-pos connector block.
	NI 9923	Use for NI 9262/9264 with DSUB.
	NI 9974	Use for NI 9264 with spring terminal. Front mount spring terminal block for 36-pos plug modules.
Power Supply(only for the 9265)	—	Use for NI 9265. Bench-top power supply with a 9-36 VDC voltage output.

## Test Conditions

The following setup and environmental conditions are required to ensure the NI 9262, 9263, 9264 or 9265 meets published specifications.

- Keep connections to the device as short as possible. Long cables and wires act as

antennas, picking up extra noise that can affect measurements.

- Use shielded copper wire for all cable connections to the device. Use twisted-pair wire to eliminate noise and thermal offsets.
- Verify that all connections to the module are secure.
- Maintain an ambient temperature of  $23\text{ }^{\circ}\text{C} \pm 5\text{ }^{\circ}\text{C}$ . The device temperature will be greater than the ambient temperature.
- Keep relative humidity below 80%.
- Allow a warm-up time of at least 10 minutes to ensure that the NI 9262/9263/9264/9265 measurement circuitry is at a stable operating temperature.

## Device Setup

1. Install the NI 9262/9263/9264/9265 module in slot 8 of the cDAQ-9178 chassis. Leave slots 1 through 7 of the chassis empty.
2. Configure the hardware using Measurement & Automation Explorer (MAX).
3. Launch the Calibration Executive procedure and complete the setup wizard.



**Note** If the NI module fails after calibration, return it to NI for repair or replacement.

## Test Limit Equations

The following test limits are derived from the published specifications found in the NI 9262, 9263, 9264 and 9265 Calibration Procedures.

**Table 75.** NI 9262/9263/9264/9265 Test Limit Equations

Equation Type	Equation
Accuracy	$\text{TestLimits} = \text{TestValue} \pm \text{AbsoluteAccuracy}$ <ul style="list-style-type: none"> <li>• <math>\text{AbsoluteAccuracy} = \text{TestValue} * \text{GainError} + \text{Range} * \text{OffsetError}</math></li> </ul>

## Related concepts:

- [Launching a Calibration Procedure](#)

# NI 9266 Calibration Procedure

Calibrate the NI 9266 using Calibration Executive.

## Calibration Executive Procedure Features

Verify Only ✓	Verify & Adjust ✓	Manual Mode ✓	Optional Adjust ✗
---------------	-------------------	---------------	-------------------

## Approximate Test Time

Verify Only	Verify & Adjust
1 minute	3 minutes

## Test Equipment

The following table lists the test equipment required for calibrating NI 9266 modules.

**Table 312.** Test equipment for calibrating the NI 9266

Instrument	Recommended Model	Requirements
DMM	NI 4070	If this instrument is unavailable, use a multiranging 6 1/2-digit DMM with a DC current measurement accuracy of 400 ppm.
Chassis	cDAQ-9178	—
Bench-top Power Supply	—	Manual power source, 9 V DC to 30 V DC output voltage with an output rated for at least 5 W.

## Test Conditions

The following setup and environmental conditions are required to ensure the NI 9266 meets published specifications.

- Keep connections to the device as short as possible. Long cables and wires act as antennas, picking up extra noise that can affect measurements.
- Use shielded copper wire for all cable connections to the device. Use twisted-pair wire to eliminate noise and thermal offsets.



- Verify that all connections to the module are secure.
- Maintain an ambient temperature of  $23\text{ }^{\circ}\text{C} \pm 5\text{ }^{\circ}\text{C}$ . The device temperature will be greater than the ambient temperature.
- Keep relative humidity below 80%.
- Allow a warm-up time of at least 10 minutes to ensure that the NI 9266 measurement circuitry is at a stable operating temperature.

## Device Setup

1. Install the NI 9266 module in slot 8 of the cDAQ-9178 chassis according to the instructions in the NI 9266 Getting Started Guide. Leave slots 1 through 7 of the chassis empty.
2. Configure the hardware using Measurement & Automation Explorer (MAX).
3. Launch the Calibration Executive procedure and complete the setup wizard.



**Note** If the module fails after calibration, return it to NI for repair or replacement.

Figure 1. Connection Diagram

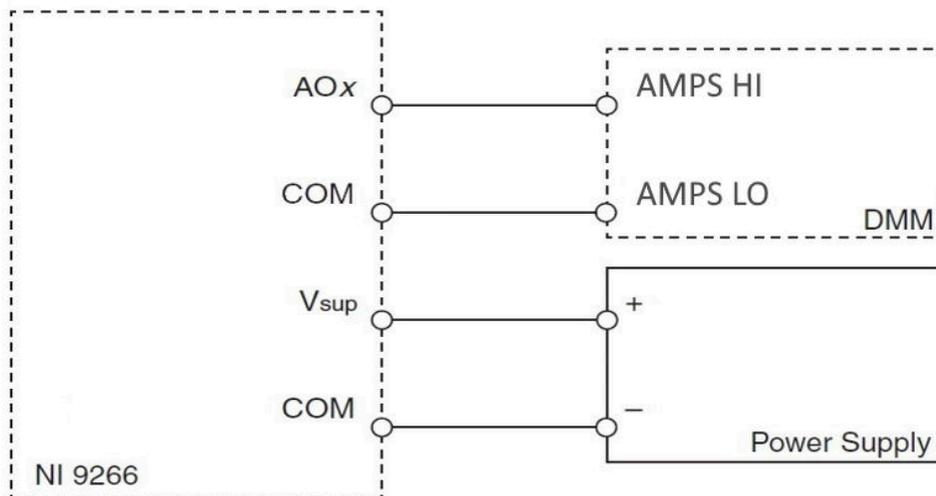

**Hazardous Voltage** Disable the bench-top power supply before changing connections. Re-enable power when the connections are secure.

## Related concepts:

- [Launching a Calibration Procedure](#)

# NI 9269 Calibration Procedure

Calibrate the NI 9269 using Calibration Executive.

## Calibration Executive Procedure Features

Verify Only ✓	Verify & Adjust ✓	Manual Mode ✓	Optional Adjust ✗
---------------	-------------------	---------------	-------------------

## Approximate Test Time

3 minutes

## Test Equipment

The following table lists the test equipment required for calibrating NI 9269 modules.

**Table 312.** Test equipment for calibrating the NI 9269

Instrument	Recommended Model	Requirements
DMM	NI 4070 DMM	If this instrument is unavailable, use a multiranging 6 1/2-digit DMM with a voltage accuracy of $\pm 400$ ppm.
Chassis	cDAQ-9178	—

## Test Conditions

The following setup and environmental conditions are required to ensure the NI 9269 meets published specifications.

- Keep connections to the NI 9269 as short as possible. Long cables and wires act as antennas, picking up extra noise that can affect measurements.
- Verify that all connections to the NI 9269 are secure.
- Use shielded copper wire for all cable connections to the NI 9269. Use twisted-pair wire to eliminate noise and thermal offsets.
- Maintain an ambient temperature of  $23\text{ }^{\circ}\text{C} \pm 5\text{ }^{\circ}\text{C}$ . The NI 9269 temperature will be greater than the ambient temperature.
- Keep relative humidity below 80%.

- Allow a warm-up time of at least 10 minutes to ensure that the NI 9269 measurement circuitry is at a stable operating temperature.

## Device Setup

1. Install the NI 9269 in slot 8 of the cDAQ-9178 chassis. Leave slots 1 through 7 on the cDAQ-9178 chassis empty.
2. Connect the cDAQ-9178 chassis to your host computer.
3. Connect the power source to the cDAQ-9178 chassis.
4. Configure the hardware using Measurement & Automation Explorer (MAX).
5. Launch the Calibration Executive procedure and complete the setup wizard.

## Test Limit Equations

The following test limits are derived from the published specifications found in the NI 9269 Calibration Procedure.

**Table 78.** NI 9269 Test Limit Equations

Equation Type	Equation
Voltage Accuracy	$\text{VoltageAccuracyLimit} = \text{TestValue} \pm [(\text{TestValue} * 0.06\%) + (\text{Range} * 0.015\%)]$

## Related concepts:

- [Launching a Calibration Procedure](#)

## NI 9361 Calibration Procedure

Calibrate the NI 9361 using Calibration Executive.

## Calibration Executive Procedure Features

Verify Only ✓	Verify & Adjust ☒	Manual Mode ✓	Optional Adjust ☒
---------------	-------------------	---------------	-------------------

## Approximate Test Time

Warmup	Verify Only
30 minutes	5 minutes

## Test Equipment

The following table lists the test equipment required for calibrating NI 9361 modules.

**Table 312.** Test equipment for calibrating the NI 9361

Instrument	Recommended Model	Requirements
Frequency Standard	Keysight 33250A	A highly stable clock source that is able to generate 1 MHz, 5 V TTL output with $\leq \pm 5$ ppm total accuracy
Chassis	cDAQ-9178	—
Connection Accessory	NI 9923	—

## Test Conditions

The following setup and environmental conditions are required to ensure the NI 9361 meets published specifications.

- Keep connections to the NI 9361 as short as possible. Long cables and wires act as antennas, picking up extra noise that can affect measurements.
- Verify that all connections to the NI 9361 are secure.
- Maintain an ambient temperature of  $23\text{ }^{\circ}\text{C} \pm 5\text{ }^{\circ}\text{C}$ . The NI 9361 temperature will be greater than the ambient temperature.
- Keep relative humidity below 80%.

## Device Setup

1. Make sure the cDAQ-9178 power source is not connected.
2. Attach a ring lug to a 14 AWG (1.6 mm) wire. Connect the ring lug to the ground terminal on the side of the cDAQ-9178 using the ground screw. Attach the other end of the wire to the system safety ground.

3. Install the module in slot 8 of the cDAQ-9178 chassis. Leave slots 1 through 7 on the chassis empty.
4. Connect the cDAQ-9178 chassis to your host computer.
5. Connect the power source to the cDAQ-9178 chassis.
6. Configure the hardware using Measurement & Automation Explorer (MAX).
7. Launch the Calibration Executive procedure and complete the setup wizard.

## Test Limit Equations

The following test limits are derived from the published specifications found in the NI 9361 Calibration Procedure.

**Table 80.** NI 9361 Test Limit Equations

Equation Type	Equation
Base Clock Accuracy	Accuracy = $\pm 50.0$ ppm

### Related concepts:

- [Launching a Calibration Procedure](#)

## Counter/Timer Device Calibration Procedures

Calibrate your counter/timer devices with Calibration Executive.

### PXIe-6614 Calibration Procedure

Calibrate the PXIe-6614 using Calibration Executive.

### Calibration Executive Procedure Features

Verify Only ✓	Verify & Adjust ✓	Manual Mode ✓	Optional Adjust ✗
---------------	-------------------	---------------	-------------------

## Approximate Test Time

Verify Only	Verify & Adjust
3 minutes	9 minutes

## Test Equipment

The following table lists the test equipment required to calibrate the PXIe-6614.

**Table 81.** Test equipment for calibrating the PXIe-6614

Instrument	Recommended Model	Requirements
10 MHz rubidium frequency standard clock or better*	Symmetricom 8040C or Datum 8040	$\pm 0.75$ ppb <sup>†</sup> accuracy or better
Shielded 68-conductor cable	Sh68-68-D1	Terminated with 68-pin female 0.050 series D-type connector
I/O connector block	BNC-2121, SCB-68A, or any 68-pin breakout box	—
BNC male-to-BNC male cable	—	50 $\Omega$
75 $\Omega$ BNC male to 50 $\Omega$ BNC female adapter	—	50 to 75 $\Omega$



### Note

- \*Allow adequate time for the clock to warm up prior to calibration.
- <sup>†</sup>1 ppb = 1/1000,000,000

## Test Conditions

The following setup and environmental conditions are required to ensure the PXIe-6614 meets published specifications.

- Keep connections to the device as short as possible. Long cables and wires act as antennas, picking up extra noise that can affect measurements.
- Verify that all connections to the device, including front panel connections, are

secure.

- Use shielded coaxial cables or shielded copper wire for all cable connections to the device. Use twisted-pair wire to eliminate noise and thermal offsets.
- Maintain an ambient temperature of 23 °C ± 5°C.
- Keep relative humidity between 5% and 95%, non-condensing.
- Allow a warm up time of at least two hours to ensure that the measurement circuitry is at a stable operating temperature.

### Device Setup

1. Power off the PXI Express chassis, and install the PXIe-6614 in an available slot.
2. Power on the chassis and launch MAX.
3. Configure the device identifier and select **Self-Test** to ensure that the device is working properly.
4. Connect the PXIe-6614 to the I/O connect or block using the shielded 68-conductor cable.
5. Connect the clock source to PFI 39 on the PXIe-6614.

### Test Limit Equations

The following test limits are derived from the published specifications.

**Table 82.** PXIe-6614 Test Limit Equations

Equation Type	Equation
Clock Accuracy Verification and Adjustment	<p>Frequency = 100 MHz</p> <p>Temperature and 1-year drift = 75 ppb</p> <p>Retrace error = 10 ppb</p> <p>Calibration measurement accuracy = 4.25 ppb</p> <p>As-found Limit = Frequency * (1 ± (Temperature and 1-year drift + Retrace error)) = 100 MHz * (1 ± (75 ppb + 10 ppb)) = ± 8.5 Hz</p> <p>As-left Limit = Frequency * (1 ± Calibration measurement accuracy) = 100 MHz * (1 ± 4.25 ppb) = ± 0.425 Hz</p>

# NI 6624 Calibration Procedure

Calibrate the NI 6624 using Calibration Executive.

## Calibration Executive Procedure Features

Verify Only ✓	Verify & Adjust ✗	Manual Mode ✓	Optional Adjust ✗
---------------	-------------------	---------------	-------------------

## Approximate Test Time

Verify only
5 minutes

## Test Equipment

The following table lists the test equipment required for calibrating the NI 6624.

**Table 312.** Test equipment for calibrating the NI 6624

Instrument	Recommended Model	Requirements
External Counter	Agilent HP 53131A or HP 53132A	≤ ppm uncertainty for measurement
+5 Power Source	NI 4110	Ability to source current of at least 1 A
Discrete Resistors (x 2)	—	5% precision Resistor Values: 500 Ω
Cable	Sh100-100-F	—
Connector Block	SCB-100	—
CompactPCI-to-PCI adapter	—	—

## Test Conditions

The following setup and environmental conditions are required to ensure the NI 6624 meets published specifications.



- Keep connections to the device as short as possible. Long cables and wires act as antennas, picking up extra noise that can affect measurements.
- Verify that all connections to the device, including front panel connections, are secure.
- Maintain an ambient temperature of 25 °C. The device temperature will be greater than the ambient temperature.
- Keep relative humidity below 80%.
- Allow a warm up time of at least 15 minutes to ensure that the measurement circuitry is at a stable operating temperature.
- Use shielded copper wire for all cable connections to the device. Use twisted-pairs wire to eliminate noise and thermal offsets.
- Ensure that the PXI chassis fan speed is set to HIGH, that the fan filters are clean, and that the empty slots contain filler panels. For more information, refer to the **Maintain Forced-Air Cooling Note to Users** document available at [ni.com/docs](http://ni.com/docs).
- Plug the chassis and the instrument into the same power strip to avoid ground loops.

## Device Setup

To calibrate the onboard crystal oscillator of the PXI-6624, you must calibrate the PXI-6624 on a PCI chassis using a CompactPCI-to-PCI adapter. When using a PXI chassis, the measured frequency is that of the PXI backplane clock instead of the onboard crystal oscillator.

1. Cable the NI 6624 to a 100-pin connector block.
2. Wire the +5 V power source to the connector block:
  - a. Wire the +5 V power terminal to the connector block terminal that is connected to the PFI 36 Vdd/CTR 0 Vdd pin (pin 7) on the NI 6624.
  - b. Wire the ground of the +5 V power source to the connector block terminal that is connected to the PFI 36 Vss/CTR 0 Vss pin (pin 8) on the NI 6624.
3. Wire a 500  $\Omega$  resistor between the connector block terminals that are connected to the PFI 36 Vdd/CTR 0 Vdd pin (pin 7) and PFI 36/CTR 0 OUT pin (pin 9) on the NI 6624. Wire another 500  $\Omega$  resistor to the connector block terminal that is connected to the PFI 36/CTR 0 OUT pin (pin 9) on the NI 6624.
4. Connect the external counter to the connector block using twisted-pair wires:
  - a. Wire the input of the external counter to the other end of the 500  $\Omega$  resistor

- that is connected to the PFI 36/CTR 0 OUT pin (pin 9) on the NI 6624.
- b. Wire the ground of the external counter to the connector block terminal that is connected to the PFI 36 Vss/CTR 0 Vss pin (pin 8) on the NI 6624.

## Test Limit Equations

The following test limits are derived from the published specifications.

**Table 84.** NI 6624 Test Limit Equations

Equation Type	Equation
Timing Accuracy	<p>1 year limits are calculated as follows:</p> <ul style="list-style-type: none"> <li>• 20MHz Limit = Baseclock Accuracy * Baseclock Frequency = 0.005% * 20M = <math>\pm 1\text{kHz}</math></li> <li>• Baseclock accuracy = <math>\pm 50\text{ppm}</math> (0.005%)</li> </ul>

## NI 6652/6653/6672 Calibration Procedure

Calibrate the PXI-6652/6653 and PXIe-6672 using Calibration Executive.

### Calibration Executive Procedure Features

Verify Only ✓	Verify & Adjust ✓	Manual Mode ✓	Optional Adjust ⓧ
---------------	-------------------	---------------	-------------------

### Approximate Test Time

2 minutes (warm-up time: 6652/6672 15 minutes, 6653 24 hours)

### Test Equipment

The following table lists the test equipment required to calibrate PXI-6652/6653 and PXIe-6672 devices.

**Table 312.** Test equipment for calibrating the PXI-6652/6653 and PXIe-6672

Instrument	Recommended Model	Requirements
10 MHz Clock Source	Symmetricon/ Datum 8040	If this instrument is unavailable, use a clock source that is accurate to within 0.75 ppb for PXI-6653, and 150 ppb for PXI-6652 and PXIe-6672.
Chassis	PXI-1044, PXI-1045	Use with PXI-6652/6653 to reduce error associated in variance in the 5 V chassis supply.
	PXIe-1062	Use with PXIe-6672.
BNC-SMB Cable	—	—
SMB-SMB Cable	—	—

## Test Conditions

The following setup and environmental conditions are required to ensure the NI 6652/6653/6672 meets published specifications.

- Maintain a temperature of 25 °C.
- Keep the relative humidity below 80%.
- NI 6652/6672 Allow a warm-up time of at least 15 minutes for the NI 6652/6672 to ensure that the measurement circuitry of the device and the clock source are at a stable operating temperature.
- PXI-6653 Ensure the PXI-6653 has been continuously powered on for at least 24 hours.
- Use shielded copper wire for all cable connections to the device.
- Ensure that the PXI chassis fan speed is set to HIGH, that the fan filters are clean, and that the empty slots contain filler panels. For more information, refer to the ***Maintain Forced-Air Cooling Note to Users*** document available at [ni.com/docs](http://ni.com/docs).

## Device Setup

Complete the following steps to set up the PXI-6652/6653 and PXIe-6672 for

calibration.

1. Make sure all components involved in the calibration procedure are powered off.
2. Install the PXI-6652/6653 or PXIe-6672 board into **any compatible PXI/PXI Express slot of your chassis**.
3. Power on the PXI/PXI Express chassis first, and then the external equipment.
4. Make sure that all the appropriate driver and application software is installed on the host computer.
5. Configure the hardware properly with Measurement & Automation Explorer (MAX). Refer to the ***NI PXI-665x Installation Guide*** or the ***NI PXIe-6672 Installation Guide*** for details about configuring the PXI/PXI Express equipment.
6. Launch the Calibration Executive procedure and complete the setup wizard.

#### Related concepts:

- [Launching a Calibration Procedure](#)

## PXIe-6674T Calibration Procedure

Calibrate the PXIe-6674T using Calibration Executive.

#### Calibration Executive Procedure Features

Verify Only ✓	Verify & Adjust ✓	Manual Mode ✓	Optional Adjust ⓧ
---------------	-------------------	---------------	-------------------

#### Approximate Test Time

Warmup	Verify Only	Verify & Adjust
24 hours	1.5 minutes	7 minutes

#### Test Equipment

The following table lists the test equipment required for calibrating the PXIe-6674T.

**Table 86.** Test equipment for calibrating the PXIe-6674T

Instrument	Recommended Model	Requirements
10 MHz clock source	Symmetricon/Datum 8040	Accurate to within 0.75 parts-per-billion (ppb)
BNC-SMA cable	—	—
PXI Express chassis	PXIe-1062Q, PXIe-1075	Any PXI Express chassis meets requirements.

## Test Conditions

The following setup and environmental conditions are required to ensure the PXIe-6674T meets published specifications.

- Keep connections to the device as short as possible. Long cables and wires act as antennas, picking up extra noise that can affect measurements.
- Verify that all connections to the device, including front panel connections, are secure.
- Maintain an ambient temperature of  $25\text{ }^{\circ}\text{C} \pm 5\text{ }^{\circ}\text{C}$ .
- Keep relative humidity below 80%.
- Ensure the PXIe-6674T has been continuously powered on for at least 24 hours.
- Use shielded copper wire for all cable connections to the device. Use twisted-pairs wire to eliminate noise and thermal offsets.
- Ensure that the PXI chassis fan speed is set to HIGH, that the fan filters are clean, and that the empty slots contain filler panels. For more information, refer to the ***Maintain Forced-Air Cooling Note to Users*** document available at [ni.com/docs](http://ni.com/docs).

## Device Setup

1. Install the PXIe-6674T board into **any PXI Express slot of your PXI Express chassis**. Refer to the ***NI PXIe-6674T Installation Guide*** for more details.
2. Power on the PXI Express chassis.
3. Configure the hardware using Measurement & Automation Explorer (MAX).
4. Launch the Calibration Executive procedure. Calibration Executive guides you through the required connections.



**Note** The 10MHz reference clock should be connected directly to the chassis

10MHz Ref In. No connections will be made directly to the PXIe-6674T. This differs from the manual Calibration Procedure but is required for calibration to be performed in any slot within the chassis.

## Test Limit Equations

The following test limits are derived from the published specifications.

**Table 87.** PXIe-6674T Test Limit Equations

Equation Type	Equation
Timing Accuracy	<p>1 year limits are calculated as follows:</p> <ul style="list-style-type: none"> <li>• Limit = Retrace Error + Long Term Stability + Stability vs. Temperature = <math>\pm 56.5</math> ppb for one year specs</li> <li>• Retrace Error = <math>\pm 1.5</math> ppb</li> <li>• Long Term Stability = <math>\pm 50</math> ppb/year</li> <li>• Stability vs. Temperature = <math>\pm 5</math> ppb, referenced at 25 °C</li> </ul>

## PXI-6683/6683H Calibration Procedure

Calibrate the PXI-6683 or PXI-6683H using Calibration Executive.

### Calibration Executive Procedure Features

Verify Only ✓	Verify & Adjust ✓	Manual Mode ✓	Optional Adjust ✗
---------------	-------------------	---------------	-------------------

### Approximate Test Time

Warmup	Verify Only	Verify & Adjust
15 minutes	3 minutes	9 minutes

### Test Equipment

The following table lists the test equipment required to calibrate the PXI-6683.

**Table 312.** Test equipment for calibrating the PXI-6683

Instrument	Recommended Model	Requirements
Reference Clock	Symmetricon 8040C rubidium frequency standard or PXIe-6674T	Accuracy: 100 ppb or better Frequency: 10 MHz
PXI or PXI Express Chassis	PXIe-1065 or PXI-1045	If these chassis are unavailable, use any chassis with an available PXI slot.  PXI-6683 Series boards require a full PXI slot.  The chassis must be able to lock its PXI_CLK10 to the 10 MHz calibration reference clock. Refer to the PXI chassis user manual for more information.

The following table lists the test equipment required to calibrate the PXI-6683H.

Instrument	Recommended Model	Requirements
Reference Clock	Symmetricon 8040C rubidium frequency standard or PXIe-6674T	Accuracy: 100 ppb or better Frequency: 10 MHz
PXI or PXI Express Chassis	PXIe-1065 or PXIe-1085	If these chassis are unavailable, use any chassis with an available PXI slot or PXI Express hybrid slot.  PXI-6683H boards can be installed in a full PXI slot or a PXI Express hybrid slot.  The chassis must be able to lock its PXI_CLK10 to the 10 MHz calibration reference clock. Refer to the PXI chassis user manual for more information.

## Test Conditions

The following setup and environmental conditions are required to ensure the PXI-6683 meets published specifications.

- Use one of the following methods to ensure the 10 MHz reference clock is present at PXI\_CLK10 in the chassis:
  - Connect the 10 MHz reference signal directly to the 10 MHz Reference IN connector of the chassis.
  - Configure the timing and synchronization board in the timing slot of the chassis to route its CLKIN input to PXI\_CLK10\_IN.
  - Use the timing and synchronization board being calibrated to route the 10 MHz reference clock to PXI\_CLK10\_IN.
- Externally connect the ClkOut terminal of the PXI-6683 or PXI-6683H board to the PFI0 terminal.
- Keep connections as short as possible. Long cables and wires act as antennas, picking up extra noise that can affect measurements.
- Verify that all connections to the device, including front panel connections, are secure.
- Maintain an ambient temperature of  $23\text{ }^{\circ}\text{C} \pm 3^{\circ}\text{C}$ . The device temperature will be greater than the ambient temperature.



**Note** Do not use the device and calibration temperature reported by MAX. The device and calibration temperature reported by MAX are the internal temperature readings of the FPGA, not the ambient temperature.

- Keep relative humidity between 10% and 90% non-condensing.
- Allow at least 15 minutes of warm-up time for the DUT.
- Allow a warm up time for each of the instruments used in this procedure according to the specific instruments operating instructions.

## Device Setup

1. Install the PXI-6683/6683H according to the instructions in the NI PXI-6683 Series Installation Guide.
2. Configure the hardware using Measurement & Automation Explorer (MAX).
3. Launch the Calibration Executive procedure and complete the setup wizard.

Calibration Executive guides you through the connections required for calibration.

## Test Limit Equations

The following test limits are derived from the published specifications.



TestLimit = TestValue ± (TestValue \* Accuracy)

### Related concepts:

- [Launching a Calibration Procedure](#)

## Data Acquisition (DAQ) Device Calibration Procedures

Calibrate your DAQ devices with Calibration Executive.

### Analog Output DAQ Devices

Calibrate your analog output DAQ devices with Calibration Executive.

### NI 6703/6704 Calibration Procedure

Calibrate the NI 6703/6704 using Calibration Executive.

### Calibration Executive Procedure Features

Verify Only ✓	Verify & Adjust ✓	Manual Mode ✓	Optional Adjust ✗
---------------	-------------------	---------------	-------------------

### Approximate Test Time

2 minutes

### Test Equipment

The following table lists the test equipment required to calibrate NI 6703/6704 modules.

**Table 312.** Test equipment for calibrating the NI 6703/6704

Instrument	Recommended Model	Requirements
DMM	Agilent 3458A	If this instrument is unavailable, use a multiranging 5 1/2-digit DMM with an accuracy of 40 ppm.

Instrument	Recommended Model	Requirements
Chassis	PXI-1042, PXI-1042Q	Use with PXI modules.
DAQ Accessory	NI SCB-68	Shielded I/O connector block with 68 screw terminals for easy signal connection to 68- or 100-pin DAQ devices.
	NI CB-68LP, NI CB-68LPR, NI TBX-68	Low-cost termination accessories with 68 screw terminals for easy connection of field I/O signals to 68-pin DAQ devices.
	Shielded DAQ Cable	NI Sh68-68-EP —

## Test Conditions

The following setup and environmental conditions are required to ensure the NI 6703/6704 meets published specifications.

- Keep connections to the device short. Long cables and wires act as antennas, picking up extra noise and thermal offsets that can affect measurements.
- Use shielded copper wire for all cable connections. Use twisted-pair wire to reduce noise.
- Maintain the temperature between 18 and 28 °C.
- Keep relative humidity below 80%.
- Allow a warm-up time of at least 15 minutes for the device to ensure that the measurement circuitry is at a stable operating temperature.
- (PXI) Ensure that the PXI chassis fan speed is set to HIGH, that the fan filters are clean, and that the empty slots contain filler panels.

## Device Setup

To set up and configure NI 6703/6704 devices for calibration, complete the following steps:

1. Install the module in the host computer or PXI chassis as described in the DAQ Getting Started Guide.
2. Configure the hardware with MAX. Refer to the help files within MAX or visit [ni.com/support](http://ni.com/support) for more configuration information.
3. Launch the Calibration Executive procedure and complete the setup wizard.
4. Connect the module and the standards following the instructions provided by Calibration Executive.
5. When the Calibration Executive procedure prompts you to enter the device name, enter the NI-DAQmx device number assigned to the NI 6703/6704 device by MAX when you configured the hardware.



**Note** If the module fails after calibration, return it to NI for repair or replacement.

### Related concepts:

- [Launching a Calibration Procedure](#)

## NI 671x/672x/673x Calibration Procedure

Calibrate the NI 671x/672x/673x using Calibration Executive.

### Calibration Executive Procedure Features

Verify Only ✓	Verify & Adjust ✓	Manual Mode ✓	Optional Adjust ⓧ
---------------	-------------------	---------------	-------------------

### Approximate Test Time

Device	Test Time
NI 671x	8 minutes
NI 672x	35 minutes
NI 673x	11 minutes

## Test Equipment

The following table lists the test equipment required to calibrate NI 671x/672x/673x modules.

**Table 312.** Test equipment for calibrating the NI 671x/672x/673x

Instrument	Recommended Model	Where Used	Requirements
Calibrator	Fluke 5700A	Adjustment	If that instrument is unavailable, use a high-precision voltage source that is at least 50 ppm accurate for 12- and 13-bit boards and 10 ppm for 16-bit boards.
DMM	PXI-4070, Agilent 3458A	Analog Output	If these instruments are unavailable, use a multi-ranging 5 1/2-digit DMM with an accuracy of 40 ppm.
Counter	Agilent 53131A	Counter	If this instrument is unavailable, use a counter with an accuracy of 0.01%.
DAQ Accessory	SCB-68	Adjustment, Analog Output,	Shielded I/O connector block with 68 screw terminals for easy signal connection to 68- or 100-pin DAQ devices.
	CB-68LP, CB-68LPR, TBX-68	Counter	Low-cost termination accessories with 68 screw terminals for easy connection of field I/O signals to 68-pin DAQ devices.
Shielded DAQ Cable	SH68-68-EP	Adjustment, Analog Output,	Use with NI 671x/672x/673x modules with a 68-pin SCSI II connector.
	SH68-C68-S	Counter	Use with PXI-6722/6723.
Chassis*	PXI-1042, PXI-1042Q	—	Use with PXI modules.



**Note** \*During calibration, PCI devices must be connected directly to the computer. PCI devices should be tested without using any PCI extender systems.



**Note** The Calibration Executive procedure runs in automated mode if you use IVI-supported calibration standards.

## Test Conditions

The following setup and environmental conditions are required to ensure the NI 671x/672x/673x meets published specifications.

- Keep connections to the module short. Long cables and wires act as antennas, picking up extra noise, which can affect measurements.
- Use shielded copper wire for all cable connections to the module.
- Use twisted-pair wire to eliminate noise and thermal offsets.
- Maintain a temperature between 18 and 28 °C. To operate the module at a specific temperature outside this range, calibrate the device at that temperature.
- Keep relative humidity below 80%.
- Allow a warm-up time of at least 15 minutes to ensure that the measurement circuitry is at a stable operating temperature.
- (PXI) Ensure that the PXI chassis fan speed is set to HIGH, that the fan filters are clean, and that the empty slots contain filler panels.

## Device Setup

To set up the module for calibration, complete the following steps:

1. Install the module in the chassis or host computer.
2. Configure the hardware with MAX. Refer to the help files within MAX or visit [ni.com/support](http://ni.com/support) for more configuration information.
3. Launch the Calibration Executive procedure and complete the setup wizard.
4. Connect the module and the standards following the instructions provided by Calibration Executive.
5. When the Calibration Executive procedure prompts you to enter the device name, enter the NI-DAQmx device number assigned to the NI 671x/672x/673x device by MAX when you configured the hardware.



**Note** If the device fails after calibration, refer to the section. If the device still fails after you complete the troubleshooting procedures, return it to NI for

repair or replacement.

## Troubleshooting Guidelines

This section describes common problems you might encounter when calibrating an NI 671x/672x/673x device and explains how to correct the problem.

If the device is not recognized by MAX, verify that you followed the configuration guidelines. Additional configuration information is available at [ni.com/support](http://ni.com/support). If MAX fails to recognize the device after you reconfigure and refresh (<F5>), contact NI technical support.

If the device fails after calibration, complete the following steps:

1. Check the connections and run the Calibration Executive procedure again.
2. If the calibration still fails, try generating the failed Test Points using the test panel in MAX. For example, if the analog output (AO) failed at 9.99 V on channel 1, complete the following steps:
  - a. Launch the test panel in MAX.
  - b. Click the **Analog Output** tab.
  - c. Select **channel 1** from the Channel Selection pull-down menu.
  - d. Set the DC voltage to 9.99 V.
  - e. Click **Update Channel**.
  - f. Read the value from the DMM.

If the reading from the DMM still fails after you complete steps 1 and 2, contact NI for repair or replacement. If the reading passes, you can change the calibration report to indicate the passing value.



**Note** If you have Microsoft Access 2000 or later, you can also modify the database containing the test results. The default installation directory of this database is `Program Files\National Instruments\Calibration Executive\Databases\Calibration Reports.mdb`.

## Test Limit Equations

The following test limits are derived from the published specifications.

**Table 91.** NI 671x/672x/673x Test Limit Equations

Equation Type	Equation
Voltage	$\text{TestLimits} = \text{TestValue} M [\text{abs}(\text{TestValue}) * \% \text{ of reading} + \text{Offset}]$
Frequency	$\text{TestLimits} = \text{TestValue} M [\text{abs}(\text{TestValue}) * 0.01\%]$

### Related concepts:

- [Automated Mode Versus Manual Mode](#)
- [Launching a Calibration Procedure](#)

## NI 6738/6739 Calibration Procedure

Calibrate PCIe-6738 and PXIe-6738/6739 devices and modules using Calibration Executive.

### Calibration Executive Procedure Features

Verify Only ✓	Verify & Adjust ✓	Manual Mode ✓	Optional Adjust ✗
---------------	-------------------	---------------	-------------------

### Approximate Test Time

22 minutes



**Note** The counter function of the device is not adjustable. In case of an error, return the device to NI for repair.

### Test Equipment

The following table lists the test equipment required to calibrate PCIe-6738 and PXIe-6738/6739 devices and modules.

**Table 312.** Test equipment for calibrating the PCIe-6738 and PXIe-6738/6739

Instrument	Recommended Model	Where Used	Requirements
DMM	PXI-4070	Analog Output Verifications and Adjustment	If this instrument is unavailable, use a multi-ranging 6 1/2-digit DMM with an accuracy of 40 ppm or better.
Counter	Agilent 53220A	Counter Verification	Whether using the recommended instrument or another counter, you must ensure that it is configured to be at least 12.5 ppm (0.00125%) accurate.
PXI Express Chassis	PXIe-1062Q	—	Use with PXIe-6738/6739 modules.
Shielded DAQ Cable	SHC68-68-A2	—	Use with the NI 6738/6739.
	SHC68-C68-S	—	Use when connecting signals using the NI-6738 Adapter or NI-6739 Adapter.
DAQ Accessory	SCB-68, SCB-68A	—	Shielded I/O connector block with 68 screw terminals for easy signal connection to the NI 6738/6739.
	CB-68LP, CB-68LPR, TBX-68	—	Low-cost termination accessories with 68 screw terminals for easy connection of field I/O signals to the NI 6738/6739.

In addition, the following equipment is required to build your own switch fixture:

- PXI/PXIe-2529 (x2)
- TB-2636 terminal blocks (x2)
- NI SHC68-NT-S cables (x2)

## Test Conditions

The following setup and environmental conditions are required to ensure the NI 6738/6739 meets published specifications.

- Keep connections to the device as short as possible. Long cables and wires act as antennas, picking up extra noise that can affect measurements.
- Use shielded copper wire for all cable connections to the device. Use twisted-pair



wire to eliminate noise and thermal offsets.

- Verify that all connections to the NI 6738/6739 are secure.
- Maintain an ambient temperature of  $23\text{ }^{\circ}\text{C} \pm 5\text{ }^{\circ}\text{C}$ . The device temperature will be greater than the ambient temperature.
- For valid test limits, maintain the device temperature within  $\pm 10\text{ }^{\circ}\text{C}$  from the last external calibration.
- Keep relative humidity below 80%.
- Allow a warm-up time of at least 15 minutes to ensure that the measurement circuitry is at a stable operating temperature.
- Verify that the counter is connected directly through the terminal block when using the switch fixture.

## Device Setup

To set up the device for calibration, complete the following steps:

1. Install the NI 6738/6739 module in the chassis.
2. Configure the hardware using Measurement & Automation Explorer (MAX).
3. Launch the Calibration Executive procedure and complete the setup wizard.
4. Connect the switch fixture to the system as indicated in the **NI 6738/6739 Calibration, Switch Fixture Connection Details**. Be sure to note which switch is connected to TB1 and TB2; these must correlate with NI 2529 #1 and NI 2529 #2 when configuring the devices during setup.



**Note** If the device fails after calibration, return it to NI for repair or replacement.

## Switch Maintenance

To ensure proper operation of the switches used in this procedure, you must periodically test the performance of your switches. Refer to the **NI 2503/2529 Switch Performance Test** for instructions on validating the performance of the NI 2529 used by this procedure.

## Test Limit Equations

The following test limits are derived from the published specifications.

**Table 93.** NI 6738/6739 Test Limit Equations

Equation Type	Equation
Analog Output Verification	$\text{AbsoluteAccuracy} = \text{OutputValue} * ((\text{GainError} / 106) + \text{FS}) * (\text{OffsetError} / 106)$ <ul style="list-style-type: none"> <li>• <math>\text{GainError} = \text{ResidualGainError} + \text{GainTempco} * (\text{TempChangeFromLastInternalCal}) + \text{ReferenceTempco} * (\text{TempChangeFromLastExternalCal})</math></li> <li>• <math>\text{OffsetError} = \text{ResidualOffsetError} + \text{OffsetTempco} * (\text{TempChangeFromLastInternalCal}) + \text{INL\_Error}</math></li> <li>• <math>\text{TestLimit} = \text{OutputValue} \pm \text{AbsoluteAccuracy}</math></li> </ul>
Counter Verification	$\text{AbsoluteAccuracy} = \text{OutputValue} * (\text{TimingAccuracy} / 106)$ $\text{TestLimit} = \text{OutputValue} \pm \text{AbsoluteAccuracy}$

### Related concepts:

- [Launching a Calibration Procedure](#)
- [NI 6738/6739 Calibration, Switch Fixture Connection Details](#)
- [NI 2503/2529 Switch Performance Test](#)

## NI 6738/6739 Calibration, Switch Fixture Connection Details

Table 94. Analog Output Devices

TB-2636 #1 Pin Number	TB-2636 #2 Pin Number	NI 6738/6739 Pin Description	NI 6738/6739 Pin Number	Banana/BNC Connector (if connected)
r0+	r0+	—	—	*Banana + (Red)
r0-	r0-	—	—	*Banana - (Black)
c0+	N/A	AO 0 +	Connector 0, AO 0 (pin 10)	—
c0-	N/A	AO 0 -	Connector 0, AO GND 0/1 (pin 11)	—
c1+	N/A	AO 1 +	Connector 0, AO 1 (pin 44)	—
c1-	N/A	AO 1 -	Connector 0, AO GND 0/1 (pin 11)	—
c2+	N/A	AO 2 +	Connector 0, AO 2 (pin 45)	—
c2-	N/A	AO 2 -	Connector 0, AO GND 2/3 (pin 39)	—
c3+	N/A	AO 3 +	Connector 0, AO 3 (pin 12)	—
c3-	N/A	AO 3 -	Connector 0, AO GND 2/3 (pin 39)	—
c4+	N/A	AO 4 +	Connector 0, AO 4 (pin 13)	—
c4-	N/A	AO 4 -	Connector 0, AO GND 4/5 (pin 41)	—
c5+	N/A	AO 5 +	Connector 0, AO 5 (pin 47)	—
c5-	N/A	AO 5 -	Connector 0, AO GND 4/5 (pin 41)	—
c6+	N/A	AO 6 +	Connector 0, AO 6 (pin 48)	—

TB-2636 #1 Pin Number	TB-2636 #2 Pin Number	NI 6738/6739 Pin Description	NI 6738/6739 Pin Number	Banana/BNC Connector (if connected)
c6-	N/A	AO 6 -	Connector 0, AO GND 6/7 (pin 49)	—
c7+	N/A	AO 7 +	Connector 0, AO 7 (pin 15)	—
c7-	N/A	AO 7 -	Connector 0, AO GND 6/7 (pin 49)	—
c8+	N/A	AO 8 +	Connector 0, AO 8 (pin 16)	—
c8-	N/A	AO 8 -	Connector 0, AO GND 8/9/10 (pin 50)	—
c9+	N/A	AO 9 +	Connector 0, AO 9 (pin 17)	—
c9-	N/A	AO 9 -	Connector 0, AO GND 8/9/10 (pin 50)	—
c10+	N/A	AO 10 +	Connector 0, AO 10 (pin 51)	—
c10-	N/A	AO 10 -	Connector 0, AO GND 8/9/10 (pin 50)	—
c11+	N/A	AO 11 +	Connector 0, AO 11 (pin 52)	—
c11-	N/A	AO 11 -	Connector 0, AO GND 11 (pin 18)	—
c12+	N/A	AO 12 +	Connector 0, AO 12 (pin 53)	—
c12-	N/A	AO 12 -	Connector 0, AO GND 12/13 (pin 20)	—
c13+	N/A	AO 13 +	Connector 0, AO 13 (pin 54)	—
c13-	N/A	AO 13 -	Connector 0, AO GND 12/13 (pin 20)	—
c14+	N/A	AO 14 +	Connector 0, AO 14	—

TB-2636 #1 Pin Number	TB-2636 #2 Pin Number	NI 6738/6739 Pin Description	NI 6738/6739 Pin Number	Banana/BNC Connector (if connected)
			(pin 21)	
c14-	N/A	AO 14 -	Connector 0, AO GND 14/15 (pin 55)	—
c15+	N/A	AO 15 +	Connector 0, AO 15 (pin 22)	—
c15-	N/A	AO 15 -	Connector 0, AO GND 14/15 (pin 55)	—
c16+	N/A	AO 16 +	Connector 0, AO 16 (pin 23)	—
c16-	N/A	AO 16 -	Connector 0, AO GND 16/17 (pin 24)	—
c17+	N/A	AO 17 +	Connector 0, AO 17 (pin 57)	—
c17-	N/A	AO 17 -	Connector 0, AO GND 16/17(pin 24)	—
c18+	N/A	AO 18 +	Connector 0, AO 18 (pin 58)	—
c18-	N/A	AO 18 -	Connector 0, AO GND 18/19 (pin 59)	—
c19+	N/A	AO 19 +	Connector 0, AO 19 (pin 25)	—
c19-	N/A	AO 19 -	Connector 0, AO GND 18/19 (pin 59)	—
c20+	N/A	AO 20 +	Connector 0, AO 20 (pin 26)	—
c20-	N/A	AO 20 -	Connector 0, AO GND 20/21 (pin 27)	—
c21+	N/A	AO 21 +	Connector 0, AO 21 (pin 60)	—
c21-	N/A	AO 21 -	Connector 0, AO GND 20/21 (pin 27)	—

TB-2636 #1 Pin Number	TB-2636 #2 Pin Number	NI 6738/6739 Pin Description	NI 6738/6739 Pin Number	Banana/BNC Connector (if connected)
c22+	N/A	AO 22 +	Connector 0, AO 22 (pin 61)	—
c22-	N/A	AO 22 -	Connector 0, AO GND 22/23 (pin 62)	—
c23+	N/A	AO 23 +	Connector 0, AO 23 (pin 28)	—
c23-	N/A	AO 23 -	Connector 0, AO GND 22/23 (pin 62)	—
c24+	N/A	AO 24 +	Connector 0, AO 24 (pin 29)	—
c24-	N/A	AO 24 -	Connector 0, AO GND 24/25 (pin 30)	—
c25+	N/A	AO 25 +	Connector 0, AO 25 (pin 63)	—
c25-	N/A	AO 25 -	Connector 0, AO GND 24/25 (pin 30)	—
c26+	N/A	AO 26 +	Connector 0, AO 26 (pin 64)	—
c26-	N/A	AO 26 -	Connector 0, AO GND 26/27 (pin 65)	—
c27+	N/A	AO 27 +	Connector 0, AO 27 (pin 31)	—
c27-	N/A	AO 27 -	Connector 0, AO GND 26/27 (pin 65)	—
c28+	N/A	AO 28 +	Connector 0, AO 28 (pin 32)	—
c28-	N/A	AO 28 -	Connector 0, AO GND 28/29 (pin 33)	—
c29+	N/A	AO 29 +	Connector 0, AO 29 (pin 66)	—
c29-	N/A	AO 29 -	Connector 0, AO GND	—

TB-2636 #1 Pin Number	TB-2636 #2 Pin Number	NI 6738/6739 Pin Description	NI 6738/6739 Pin Number	Banana/BNC Connector (if connected)
			28/29 (pin 33)	
c30+	N/A	AO 30 +	Connector 0, AO 30 (pin 67)	—
c30-	N/A	AO 30 -	Connector 0, AO GND 30/31 (pin 68)	—
c31+	N/A	AO 31 +	Connector 0, AO 31 (pin 34)	—
c31-	N/A	AO 31 -	Connector 0, AO GND 30/31 (pin 68)	—
N/A	c0+	AO 32 +	Connector 1, AO 32 (pin 10)	—
N/A	c0-	AO 32 -	Connector 1, AO GND 32/33 (pin 11)	—
N/A	c1+	AO 33 +	Connector 1, AO 33 (pin 44)	—
N/A	c1-	AO 33 -	Connector 1, AO GND 32/33 (pin 11)	—
N/A	c2+	AO 34 +	Connector 1, AO 34 (pin 45)	—
N/A	c2-	AO 34 -	Connector 1, AO GND 34/35 (pin 46)	—
N/A	c3+	AO 35 +	Connector 1, AO 35 (pin 12)	—
N/A	c3-	AO 35 -	Connector 1, AO GND 34/35 (pin 46)	—
N/A	c4+	AO 36 +	Connector 1, AO 36 (pin 13)	—
N/A	c4-	AO 36 -	Connector 1, AO GND 36/37 (pin 14)	—
N/A	c5+	AO 37 +	Connector 1, AO 37 (pin 47)	—

TB-2636 #1 Pin Number	TB-2636 #2 Pin Number	NI 6738/6739 Pin Description	NI 6738/6739 Pin Number	Banana/BNC Connector (if connected)
N/A	c5-	AO 37 -	Connector 1, AO GND 36/37 (pin 14)	—
N/A	c6+	AO 38 +	Connector 1, AO 38 (pin 48)	—
N/A	c6-	AO 38 -	Connector 1, AO GND 38/39 (pin 49)	—
N/A	c7+	AO 39 +	Connector 1, AO 39 (pin 15)	—
N/A	c7-	AO 39 -	Connector 1, AO GND 38/39 (pin 49)	—
N/A	c8+	AO 40 +	Connector 1, AO 40 (pin 16)	—
N/A	c8-	AO 40 -	Connector 1, AO GND 40/41/42 (pin 50)	—
N/A	c9+	AO 41 +	Connector 1, AO 41 (pin 17)	—
N/A	c9-	AO 41 -	Connector 1, AO GND 40/41/42 (pin 50)	—
N/A	c10+	AO 42 +	Connector 1, AO 42 (pin 51)	—
N/A	c10-	AO 42 -	Connector 1, AO GND 40/41/42 (pin 50)	—
N/A	c11+	AO 43 +	Connector 1, AO 43 (pin 52)	—
N/A	c11-	AO 43 -	Connector 1, AO GND 43 (pin 18)	—
N/A	c12+	AO 44 +	Connector 1, AO 44 (pin 53)	—
N/A	c12-	AO 44 -	Connector 1, AO GND 44/45 (pin 20)	—
N/A	c13+	AO 45 +	Connector 1, AO 45	—



TB-2636 #1 Pin Number	TB-2636 #2 Pin Number	NI 6738/6739 Pin Description	NI 6738/6739 Pin Number	Banana/BNC Connector (if connected)
			(pin 54)	
N/A	c13-	AO 45 -	Connector 1, AO GND 44/45 (pin 20)	—
N/A	c14+	AO 46 +	Connector 1, AO 46 (pin 21)	—
N/A	c14-	AO 46 -	Connector 1, AO GND 46/47 (pin 55)	—
N/A	c15+	AO 47 +	Connector 1, AO 47 (pin 22)	—
N/A	c15-	AO 47 -	Connector 1, AO GND 46/47 (pin 55)	—
N/A	c16+	AO 48 +	Connector 1, AO 48 (pin 23)	—
N/A	c16-	AO 48 -	Connector 1, AO GND 48/49 (pin 24)	—
N/A	c17+	AO 49 +	Connector 1, AO 49 (pin 57)	—
N/A	c17-	AO 49 -	Connector 1, AO GND 48/49 (pin 24)	—
N/A	c18+	AO 50 +	Connector 1, AO 50 (pin 58)	—
N/A	c18-	AO 50 -	Connector 1, AO GND 50/51 (pin 59)	—
N/A	c19+	AO 51 +	Connector 1, AO 51 (pin 25)	—
N/A	c19-	AO 51 -	Connector 1, AO GND 50/51 (pin 59)	—
N/A	c20+	AO 52 +	Connector 1, AO 52 (pin 26)	—
N/A	c20-	AO 52 -	Connector 1, AO GND 52/53 (pin 27)	—

TB-2636 #1 Pin Number	TB-2636 #2 Pin Number	NI 6738/6739 Pin Description	NI 6738/6739 Pin Number	Banana/BNC Connector (if connected)
N/A	c21+	AO 53 +	Connector 1, AO 53 (pin 60)	—
N/A	c21-	AO 53 -	Connector 1, AO GND 52/53 (pin 27)	—
N/A	c22+	AO 54 +	Connector 1, AO 54 (pin 61)	—
N/A	c22-	AO 54 -	Connector 1, AO GND 54/55 (pin 62)	—
N/A	c23+	AO 55 +	Connector 1, AO 55 (pin 28)	—
N/A	c23-	AO 55 -	Connector 1, AO GND 54/55 (pin 62)	—
N/A	c24+	AO 56 +	Connector 1, AO 56 (pin 29)	—
N/A	c24-	AO 56 -	Connector 1, AO GND 56/57 (pin 30)	—
N/A	c25+	AO 57 +	Connector 1, AO 57 (pin 63)	—
N/A	c25-	AO 57 -	Connector 1, AO GND 56/57 (pin 30)	—
N/A	c26+	AO 58 +	Connector 1, AO 58 (pin 64)	—
N/A	c26-	AO 58 -	Connector 1, AO GND 58/59 (pin 65)	—
N/A	c27+	AO 59 +	Connector 1, AO 59 (pin 31)	—
N/A	c27-	AO 59 -	Connector 1, AO GND 58/59 (pin 65)	—
N/A	c28+	AO 60 +	Connector 1, AO 60 (pin 32)	—
N/A	c28-	AO 60 -	Connector 1, AO GND	—

TB-2636 #1 Pin Number	TB-2636 #2 Pin Number	NI 6738/6739 Pin Description	NI 6738/6739 Pin Number	Banana/BNC Connector (if connected)
			60/61 (pin 33)	
N/A	c29+	AO 61 +	Connector 1, AO 61 (pin 66)	—
N/A	c29-	AO 61 -	Connector 1, AO GND 60/61 (pin 33)	—
N/A	c30+	AO 62 +	Connector 1, AO 62 (pin 67)	—
N/A	c30-	AO 62 -	Connector 1, AO GND 62/63 (pin 68)	—
N/A	c31+	AO 63 +	Connector 1, AO 63 (pin 34)	—
N/A	c31-	AO 63 -	Connector 1, AO GND 62/63 (pin 68)	—



**Note** \*Connects to DMM. Use twisted pair wires.

**Table 95.** Counter Devices

TB-2636 #1 Pin Number	TB-2636 #2 Pin Number	NI 6738/6739 Pin Description	NI 6738/6739 Pin Number	Banana/BNC Connector (if connected)
—	—	Counter 0 +	CTR 0 OUT/PFI 7/P1.7 (Connector 0, pin 9)	†BNC+
—	—	Counter 0 -	D GND PFI 6/7 (Connector 0, pin 42)	†BNC-



**Note** †Connects to Counter. Use twisted pair wires.

## NI 2503/2529 Switch Performance Test

Test the performance of the PXI-2503 and PXI/PXIe-2529 using Calibration Executive.

## Calibration Executive Procedure Features

Verify only ✓	Verify & Adjust ⓧ	Manual Mode ✓	Optional Adjust ⓧ
---------------	-------------------	---------------	-------------------

## Approximate Test Time

Device	Performance Test
PXI-2503	3 minutes
PXI/PXIe-2529	8 minutes

## Test Equipment

The following table lists the test instruments required for testing the NI 2503/2529.

**Table 170.** Equipment for testing PXI-2503 and PXI/PXIe-2529 performance

Instrument	Recommended Model	Requirements
DMM	PXI-4071	Voltage Accuracy: 7.5 digits Resistance Accuracy: 6.5 digits
Terminal Block	PXI-2503: TB-2606 PXI/PXIe-2529: TB-2636	—

The switch performance tests should be executed periodically on switches used with Calibration Executive procedures to check if any switch paths have become damaged, or if the switches are approaching the end of their useful life. The frequency of execution of these tests will depend on many factors, including how often the switches are used.

## Test Conditions

The following setup and environmental conditions are required to ensure the NI 2503/2529 meets published specifications.

- Keep connections to the device as short as possible. Long cables and wires act as antennas, picking up extra noise that can affect measurements.
- Verify that all connections to the device are secure.
- Use shielded copper wire for all cable connections to the device. Use twisted-pair wire to eliminate noise and thermal offsets.
- Maintain an ambient temperature of  $23\text{ }^{\circ}\text{C} \pm 5\text{ }^{\circ}\text{C}$ . The device temperature will be greater than the ambient temperature.
- Keep relative humidity below 80%.

## Device Setup

1. Configure the hardware using Measurement & Automation Explorer (MAX).
2. Launch the Calibration Executive procedure and complete the setup wizard.
3. Complete the following steps to create fixtures that will be used to connect the switches to the DMM.

### Create the NI 2529 Fixture

1. On the TB-2636, connect the positive (+) and negative (-) terminals together for C0—C31.
2. Connect all + terminals together for R0 to R3, and wire them out using two separate wires to banana connectors labeled "DMM HI" and "DMM HI Sense".
3. Connect all - terminals together for R0 to R3, and wire them out using two separate wires to banana connectors labeled "DMM LO" and "DMM LO Sense".

To run the procedure, connect the TB-2636 to the PXI/PXIe-2529 switch, and connect the four banana connectors to the appropriate terminals on the DMM.

### Create the NI 2503 Fixture

1. On the TB-2606, connect the + and - terminals together for C0 to C5.
2. Connect all + terminals together for R0 to R3, and wire them out using two separate wires to banana connectors labeled "DMM HI" and "DMM HI Sense".
3. Connect all - terminals together for R0 to R3, and wire them out using two separate wires to banana connectors labeled "DMM LO" and "DMM LO Sense".

To run the procedure, connect the TB-2606 to the PXI-2503 switch, and connect the four banana connectors to the appropriate terminals on the DMM.

## Test Limit Equations

These switch tests are not intended to be a validation of the full warranted performance of these devices. The parameters and limits used in these tests are based on the needs of the procedures in Calibration Executive that use these switches to ensure they meet the performance requirements of those procedures.

### Related concepts:

- [Launching a Calibration Procedure](#)

## B/E/S Series and MIO 62xx/63xx Models Calibration Procedure

Calibrate B Series, E Series, MIO 62xx, S Series, and MIO 63xx devices using Calibration Executive.

### Calibration Executive Procedure Features

Verify Only ✓	Verify & Adjust ✓	Manual Mode ✓	Optional Adjust ⓧ
---------------	-------------------	---------------	-------------------

### Approximate Test Time

5 minutes

### Test Equipment

The following table lists the test equipment required to calibrate B/E/S Series and MIO 62xx/63xx devices.

**Table 97.** Test equipment for calibrating B Series, E Series, MIO 62xx, S Series, and MIO 63xx devices

Instrument	Recommended Model	Calibration Procedure	Minimum Requirements
Calibrator	Fluke 5700A	Analog Input	If this instrument is unavailable, use a high-precision voltage source that is at least 50 ppm (0.005%) accurate for 12-bit devices, and 10 ppm (0.001%) accurate for 14-, 16-, and 18-bit devices.
DMM	NI 4071	Analog	If this instrument is unavailable, use a multiranging

Instrument	Recommended Model	Calibration Procedure	Minimum Requirements
		Output	6 1/2-digit DMM with an accuracy of 40 ppm.
Counter	Agilent 53220A	Counter	If this instrument is unavailable, use a counter that is accurate to 0.01%.
DAQ Accessory	NI E/S Series or MIO 62xx model calibration hardware adapter		Connects your calibration equipment to your 68-pin E/S Series or MIO 62xx/63xx device.  For S Series devices, use revision B or later of the calibration fixture.
	NI SCC-68	Analog Input,	I/O connector block with screw terminals, general breadboard area, bus terminals, and four expansion slots for SCC signal conditioning modules.
	NI SCB-68	Analog Output,	Shielded I/O connector block with 68 screw terminals for easy signal connection to 68- or 100-pin DAQ devices.
	NI CB-68LP, NI CB-68LPR, NI TBX-68	Counter	Low-cost termination accessories with 68 screw terminals for easy connection of field I/O signals to 68-pin DAQ devices.
	NI BNC-2110		Desktop and DIN rail-mountable BNC adapter you can connect to DAQ devices.
	NI CB-37F-LP		Low-cost termination accessory with 37 screw terminals for easy connection of field I/O signals to 37-pin DAQ devices.
Low thermal Copper EMF Plug-in Cable (x2)	Fluke 5440A-7002	Analog Input, Analog Output	Do not use standard banana cables.
BNC Cable	—	Counter	Use a 50 $\Omega$ coaxial cable.
Shielded DAQ Cable	NI SH68-68-EP	Analog Input,	Use with B/E/S Series or MIO 62xx devices with a 68-pin SCSI II connector.
	NI SHC68-68-EP, NI SHC68-68-EPM, NI SHC68-68	Analog	Use with E/S Series or MIO 62xx/63xx devices with 68-pin VHDCI connectors.

Instrument	Recommended Model	Calibration Procedure	Minimum Requirements
	NI SH1006868	Output, Counter	Use with E/S Series devices with a 100-pin connector.  Connect the 68-pin cable labeled MIO-16 to the accessory. The 68-pin cable labeled Extended I/O remains unconnected.
	NI SH37F-37M-1		Use with 37-pin D-SUB B Series or MIO 62xx devices.
Chassis	PXI-1042, PXI-1042Q	—	Use with PXI modules.
	PXIe-1062Q	—	Use with PXI Express modules.



**Note** The Calibration Executive procedure runs in automated mode if you use IVI-supported instruments.

## Test Conditions

The following setup and environmental conditions are required to ensure the B/E/S Series or MIO 62xx/63xx device meets published specifications.

- Keep connections to the B/E/S Series or MIO 62xx/63xx device short. Long cables and wires act as antennas, picking up extra noise that can affect measurements.
- Use shielded copper wire for all cable connections to the device. Use twisted-pair wire to eliminate noise and thermal offsets.
- Maintain a temperature between 18 °C and 28 °C.
- Keep relative humidity below 80%.
- Allow adequate warm-up time (generally between 15 and 30 minutes for most DAQ devices) to ensure that the measurement circuitry is at a stable operating temperature. Refer to your DAQ device specifications document for the recommended warm-up time for your device.
- Temperature change affects the measurement characteristics of a device. To account for these changes, the tested specifications include the effects of temperature drift. For the B/E/S Series or MIO 62xx/63xx devices, valid temperature drift is  $\pm 10$  °C from the last external calibration temperature.
- (PXI/PXI Express) Ensure that the PXI/PXI Express chassis fan speed is set to HIGH,



that the fan filters are clean, and that the empty slots contain filler panels.

## Device Setup

1. Install the B/E/S Series or MIO 62xx/63xx device in the host computer or chassis.
2. Configure the B/E/S Series or MIO 62xx/63xx device with MAX. Refer to the Measurement & Automation Explorer Help for NI-DAQmx or the Hardware Installation/Configuration Troubleshooter for more configuration information.



**Note** *Measurement & Automation Explorer Help for NI-DAQmx* is located in the **MAX Help** under **Installed Products » NI-DAQ**.

3. Connect the appropriate shielded cables between the B/E/S Series or MIO 62xx/63xx device, the DAQ accessory, and the test instruments, as shown in the two following figures.



**Note** Fluke 5500A/5520A/5522A calibrators do not have GUARD connectors. You must connect the LO cable with the GUARD cable, then connect the GUARD cable into the LO terminal on the calibrator, as shown in the following figure.

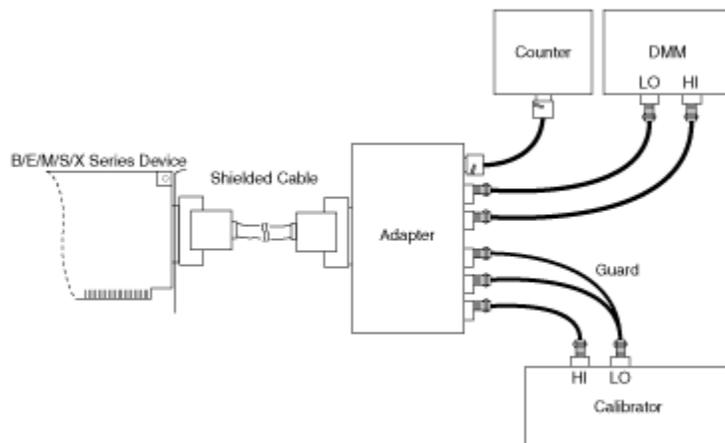

Calibrators other than the Fluke 5500A/5520A/5522A have GUARD connectors. Make the connections to these calibrators as shown in the following figure.

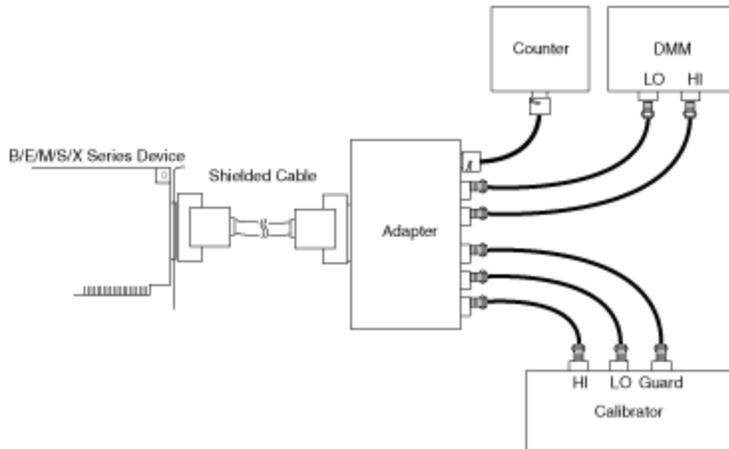

4. Launch the Calibration Executive procedure and complete the setup wizard.
5. If the Calibration procedure asks you whether to calculate measurement uncertainty, select Yes or No. If you select Yes, you are prompted to select the appropriate uncertainty files based on the standards you are using and the date the standards were last calibrated.
6. For devices supported by NI-DAQmx, the DAQmx Device ID is required in the DUT Selection dialog box.

## Troubleshooting Guidelines

This section describes common problems you might encounter when calibrating a B/E/S Series or MIO 62xx/63xx device and explains how to correct the problem. If the B/E/S Series or MIO 62xx/63xx device is not recognized by MAX, verify that you followed the configuration guidelines. If MAX fails to recognize the B/E/S Series or MIO 62xx/63xx device after you reconfigure and refresh (<F5>), contact NI technical support. If the B/E/S Series or MIO 62xx/63xx device fails after calibration, complete the following steps:

1. Check the connections and run the Calibration Executive procedure again.
2. Verify that you do not have an SCXI chassis configured in MAX. Remove the configuration if it is present and run the Calibration Executive procedure again.
3. If the calibration still fails after you complete steps 1 and 2, try inputting or outputting the failed Test Points using the test panel in MAX. For example, if the analog input (AI) failed at 0.98 V, input that value from the calibrator, as follows:
  - a. Launch the test panel in MAX.
  - b. Click the **Analog Input** tab.
  - c. Set the High Limit to 1.00 V and set the Low Limit to -1.00 V for bipolar

- readings.
- d. Check the Average Reading indicator.

If the Average Reading still fails after you complete steps 1–3, contact NI for repair or replacement. If the Average Reading passes, you can change the calibration report to indicate the passing value.

## Test Limit Equations

The following test limits are derived from the published specifications.

**Table 98.** Test Limit Equations for B/E Series

Equation Type	Equation
Analog input	$\text{TestLimits} = \text{TestValue} \pm [(\text{Input Voltage} * \text{Percentage of Reading}) + \text{Offset Volts} + \text{Noise}]$
Analog output	$\text{TestLimits} = \text{TestValue} \pm [(\text{Input Voltage} * \text{Percentage of Reading}) + \text{Offset Volts} + \text{Noise}]$
Base clock	$\text{TestLimits} = \text{TestValue} \pm 0.01\% \text{ of Actual Clock Frequency}$

**Table 99.** Test Limit Equations for NI MIO 62xx/63xx Models

Equation Type	Equation
Analog input	$\text{TestLimits} = \text{TestValue} \pm [\text{Reading (Gain Error)} + \text{Range (Offset Error)} + \text{Noise Uncertainty}]$ Absolute Accuracy on the analog input channels is determined using the following assumptions: <ul style="list-style-type: none"> <li>• Temperature Change from Last External Calibration = 10 °C</li> <li>• Temperature Change from Last Internal Calibration = 1 °C</li> </ul>
Analog output	$\text{Test Limit} = \text{TestValue} \pm [\text{Reading (Gain Error)} + \text{Range (Offset Error)}]$ Absolute Accuracy on the analog output channels is determined using the following assumptions: <ul style="list-style-type: none"> <li>• Temperature Change from Last External Calibration = 10 °C</li> <li>• Temperature Change from Last Internal Calibration = 1 °C</li> </ul>
Counter	$\text{TestLimits} = \text{TestValue} \pm (\text{TestValue} * 50 \text{ ppm})$

Equation Type	Equation
accuracy	

**Table 100.** Test Limit Equations for NI S Series

Equation Type	Equation
Analog input	$\text{TestLimits} = \text{TestValue} \pm [\text{Input (Gain Error)} + \text{Range (Offset Error)} + \text{Noise Uncertainty}]$ <p>Absolute Accuracy is determined making the following assumptions:</p> <ul style="list-style-type: none"> <li>• Temperature Change from Last External Calibration = 10 °C</li> <li>• Temperature Change from Last Internal Calibration = 1 °C</li> </ul>
Analog output	$\text{TestLimits} = \text{TestValue} \pm [\text{Output Value (Gain Error)} + \text{Range (Offset Error)}]$ <p>Absolute Accuracy is determined making the following assumptions:</p> <ul style="list-style-type: none"> <li>• Temperature Change from Last External Calibration = 10 °C</li> <li>• Temperature Change from Last Internal Calibration = 1 °C</li> </ul>
Counter accuracy	$\text{TestLimits} = \text{TestValue} \pm 0.01\% \text{ of Actual Clock Frequency}$

### Related concepts:

- [Automated Mode Versus Manual Mode](#)
- [Launching a Calibration Procedure](#)

## CompactDAQ Chassis Calibration Procedure

Calibrate a cDAQ-9171, cDAQ-9174, cDAQ-9178, cDAQ-9179, cDAQ-9181, cDAQ-9184, cDAQ-9185, cDAQ-9188, cDAQ-9189 or cDAQ-9191 chassis using Calibration Executive.



**Note** The cDAQ-9172 chassis is not supported in NI-DAQmx 17.6 and later. Therefore, cDAQ-9172 is no longer supported in Calibration Executive beginning with version 4.6. Refer to [ni.com](http://ni.com) for information about devices and modules no longer supported in NI-DAQmx.

## Calibration Executive Procedure Features

Verify Only ✓	Verify & Adjust ✗	Manual Mode ✓	Optional Adjust ✗
---------------	-------------------	---------------	-------------------

### Approximate Test Time

1 minute

### Test Equipment

The following table lists the test equipment required for calibrating CompactDAQ chassis devices.

**Table 101.** Test equipment for calibrating a cDAQ-9171, cDAQ-9174, cDAQ-9178, cDAQ-9179, cDAQ-9181, cDAQ-9184, cDAQ-9185, cDAQ-9188, cDAQ-9189 or cDAQ-9191 chassis

Instrument	Recommended Model	Requirements
Counter	Agilent 53131A	If this instrument is unavailable, use a counter accurate to $\pm 5$ ppm.
C Series Digital I/O Module	NI 9401, NI 9402	—
C Series Connection Accessory	NI 9924	(NI 9401) 25-pin DSUB to screw-terminal connector block.

### Test Conditions

The following setup and environmental conditions are required to ensure the CompactDAQ chassis meets published specifications.

- Keep connections to the C Series module as short as possible. Long cables and wires act as antennas, picking up extra noise that can affect measurements.
- Maintain an ambient temperature of  $23\text{ }^{\circ}\text{C} \pm 5\text{ }^{\circ}\text{C}$ . The device temperature will be greater than the ambient temperature.
- Keep relative humidity below 90%.
- Allow a warm-up time of at least 10 minutes to ensure that the measurement circuitry is at a stable operating temperature.

## Device Setup

1. Install the C Series digital I/O module in the CompactDAQ chassis.
2. Configure the hardware using Measurement & Automation Explorer (MAX).
3. Launch the Calibration Executive procedure and complete the setup wizard. Ensure that you enter the CompactDAQ chassis serial number in the setup wizard and not the serial number of the C Series I/O module.



**Note** If the CompactDAQ chassis module fails after calibration, return it to NI for repair or replacement.

### Related concepts:

- [Launching a Calibration Procedure](#)

### Related information:

- [Devices and Modules No Longer Supported in NI-DAQmx](#)

## FieldDAQ Devices

Calibrate your FieldDAQ devices with Calibration Executive.

### FD-11613/11614 Calibration Procedure

Calibrate the FD-11613 or FD-11614 temperature input device for FieldDAQ using Calibration Executive.

### Calibration Executive Procedure Features

Verify Only ✓	Verify & Adjust ✓	Manual Mode ✓	Optional Adjust ✗
---------------	-------------------	---------------	-------------------

### Approximate Test Time

Module	Warmup	Verify Only	Verify & Adjust
FD-11613	10 minutes	10 minutes	15 minutes

Module	Warmup	Verify Only	Verify & Adjust
FD-11614	10 minutes	15 minutes	25 minutes

## Test Equipment

The following table lists the test equipment required for calibrating the FD-11613 or FD-11614.

**Table 102.** Test equipment for calibrating the FD-11613/11614

Instrument	Recommended Model	Requirements
Calibrator	Fluke 5522A locked in the 3.3 V range	A high-precision voltage source with an uncertainty of $\leq 70$ ppm when sourcing up to 50 $\mu$ A.
Mini Thermocouple Connector (x8)	Omega SMPW-U-M	U type

## Test Conditions

The following setup and environmental conditions are required to ensure the FD-11613 or FD-11614 meets published specifications.

- Keep connections to the device as short as possible. Long cables and wires act as antennas, picking up extra noise that can affect measurements.
- Verify that all connections to the device are secure.
- Use shielded copper wire for all cable connections to the device. Use twisted-pair Teflon wire to eliminate noise and thermal offsets.
- Maintain an ambient temperature of  $23\text{ }^{\circ}\text{C} \pm 5\text{ }^{\circ}\text{C}$ . The device temperature will be greater than the ambient temperature.
- For valid test limits, maintain the device temperature within  $\pm 10\text{ }^{\circ}\text{C}$  from the last external calibration.
- Keep relative humidity below 80%.
- Allow a warm-up time of at least 10 minutes to ensure that the measurement circuitry is at a stable operating temperature.
- Verify that the counter is connected directly through the terminal block when using the switch fixture.

## Device Setup

To set up the device for calibration, complete the following steps:

1. Set up the FD-11613 or FD-11614 as outlined in the FD-11613/11614 Quick Start.



**Note** NI recommends that you use a dedicated Ethernet network adapter to connect the FD-11613 or FD-11614 to a computer or controller. Use a second Ethernet network adapter for additional network access.

2. Configure the hardware using Measurement & Automation Explorer (MAX).
3. Launch the Calibration Executive procedure and complete the setup wizard.



**Note** If the device fails after calibration, return it to NI for repair or replacement.

## Test Limit Equations

The following test limits are derived from the published specifications.

$$\text{TestLimits} = \text{TestValue} \pm (\text{TestValue} * [\text{ppm of reading}/1000000] + \text{range} * [\text{ppm of range}/100])$$

### Related concepts:

- [Launching a Calibration Procedure](#)

## NI 6349 Calibration Procedure

Calibrate PXIe-6349 and USB-6349 devices using Calibration Executive.

### Calibration Executive Procedure Features

Verify Only ✓	Verify & Adjust ✓	Manual Mode ✓	Optional Adjust ✗
---------------	-------------------	---------------	-------------------



## Approximate Test Time

Device	Warmup	Verify Only	Verify & Adjust
PXIe-6349	15 minutes	45 minutes	90 minutes
USB-6349	15 minutes	50 minutes	105 minutes

## Test Equipment

The following table lists the test equipment required to calibrate NI 6349 devices.

**Table 312.** Test equipment for calibrating the NI 6349

Instrument	Recommended Model	Calibration Procedure	Minimum Requirements
Calibrator	Fluke 5700A	Analog Input Verification, Adjustment	If this instrument is unavailable, use a high-precision voltage source that is at least 10 ppm (0.001%) accurate for 16-bit devices.
DMM	NI 4071	Analog Output Verification	If this instrument is unavailable, use a multiranging 6 1/2-digit DMM with an accuracy of 40 ppm.
Counter	Agilent 53220A	Counter Verification	Whether using the recommended instrument or another counter, you must ensure that it is configured to be at least 12.5 ppm (0.00125%) accurate.
Chassis	PXIe-1062Q	—	—
Low thermal Copper EMF Plug-in Cable (x2)	Fluke 5440A-7002	Analog Input, Analog Output	Do not use standard banana cables.
DAQ Accessories*	NI E/M/S Series calibration hardware adapter	Analog Input, Analog	Connects your calibration equipment to the PXIe-6349.

Instrument	Recommended Model	Calibration Procedure	Minimum Requirements
	NI SCB-68	Output, Counter	Shielded I/O connector block with 68 screw terminals for easy signal connection to 68- or 100-pin DAQ devices.
Shielded DAQ Cable	NI SHC68-68-EPM	—	—



**Note** \*Hardware adapter, connector block, and shielded DAQ cable are required only for the PXI Express variant, PXIe-6349.

## Test Conditions

The following setup and environmental conditions are required to ensure the NI 6349 meets published specifications.

- Keep connections to the device as short as possible. Long cables and wires act as antennas, picking up extra noise that can affect measurements.
- Verify that all connections to the device are secure.
- Use shielded copper wire for all cable connections to the device. Use twisted-pair wire to eliminate noise and thermal offsets.
- Maintain a temperature between 18 °C and 28 °C.
- Keep relative humidity below 80%.
- Allow a warm-up time of at least 15 minutes to ensure that the NI 6349 measurement circuitry is at a stable operating temperature.
- Temperature change affects the measurement characteristics of a device. To account for these changes, the tested specifications include the effects of temperature drift. For the NI 6349, valid temperature drift is  $\pm 10$  °C from the last external calibration temperature.
- (PXI/PXI Express) Ensure that the PXI/PXI Express chassis fan speed is set to HIGH, that the fan filters are clean, and that the empty slots contain filler panels.

## Device Setup for the PXIe-6349

To set up the PXIe-6349 for calibration, complete the following steps:

1. Install the PXIe-6349 module in the chassis.
2. Configure the PXIe-6349 using Measurement & Automation Explorer (MAX). Refer to the ***Measurement & Automation Explorer Help for NI-DAQmx*** or the Hardware Installation/Configuration Troubleshooter for more configuration information.



**Note** *Measurement & Automation Explorer Help for NI-DAQmx* is located in the MAX Help under **Installed Products** » **NI-DAQ**.

3. Connect the test instruments to the calibration hardware adapter, and use the shielded DAQ cable to connect the adapter to Connector 0 (AI 0–7) on the PXIe-6349 module.  
If you use the recommended calibrator or another Fluke 57xx calibrator with this procedure, make sure that the external ground is connected to the guard connector.

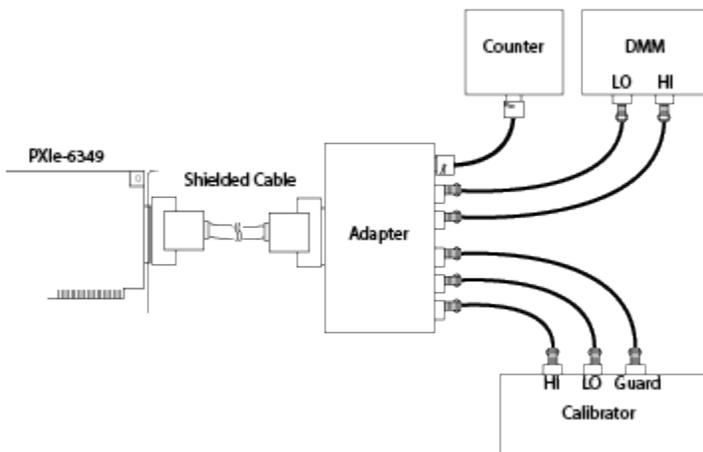

If you use a Fluke 55xx calibrator with this procedure, you must connect the LO cable with the GUARD cable, then connect the GUARD cable into the LO terminal on the calibrator.

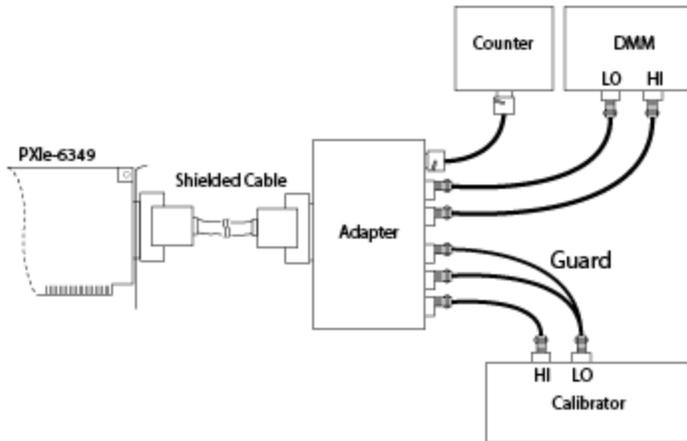

- Set the DIP switches for the SCB-68 DAQ accessory as shown in the following diagram.

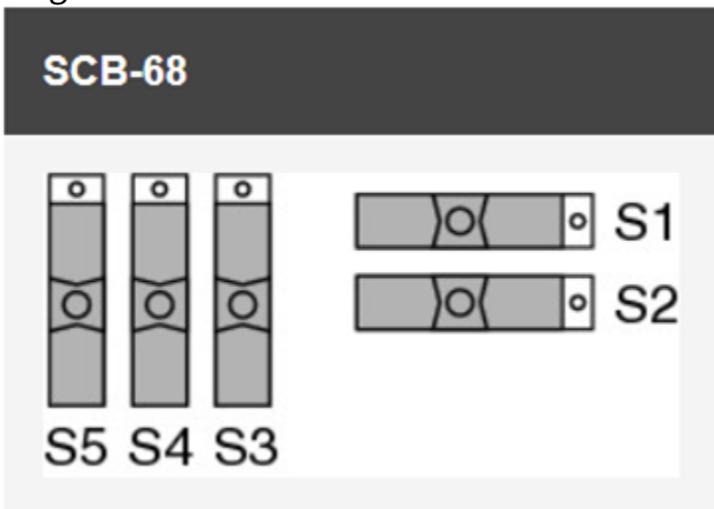

**Note** Use the SCB-68 and Connector 1 on the DUT for channels AI 8–31.

- Launch the Calibration Executive procedure and complete the setup wizard.
- If the procedure prompts you to calculate measurement uncertainty, select **Yes** or **No**. If you select **Yes**, you are prompted to select the appropriate uncertainty files based on the standards you are using and the date the standards were last calibrated.
- For devices supported by NI-DAQmx, the DAQmx Device ID is required in the DUT Selection dialog box.

## Device Setup for the USB-6349

To set up the USB-6349 (Screw Terminal) for calibration, complete the following steps:

1. Connect the USB-6349 to the host PC.
2. Configure the USB-6349 using MAX. Refer to the Measurement & Automation Explorer Help for NI-DAQmx or the Hardware Installation/Configuration Troubleshooter for more configuration information.



**Note** *Measurement & Automation Explorer Help for NI-DAQmx* is located in the MAX Help under **Installed Products » NI-DAQ**.

3. Launch the Calibration Executive procedure. Calibration Executive guides you through the required connections.
4. Be prepared to do one of the following during calibration:
  - Wire the positive, negative, and guard terminals for each channel, one-by-one, during calibration.
  - Connect short wires in advance to the positive, negative, and guard terminals for each channel, and then use clips to move to the proper channel during calibration.

## Test Limit Equations

The following test limits are derived from the published specifications.

**Table 104.** NI 6349 Test Limit Equations

Equation Type	Equation
Analog Input	$\text{TestLimits} = \text{TestValue} \pm [\text{Reading (Gain Error)} + \text{Range (Offset Error)} + \text{Noise Uncertainty}]$ <ul style="list-style-type: none"> <li>• Absolute Accuracy on the analog input channels is determined using the following assumptions:               <ul style="list-style-type: none"> <li>◦ Temperature Change from Last External Calibration = 10 °C</li> <li>◦ Temperature Change from Last internal Calibration = 1 °C</li> </ul> </li> </ul>

Equation Type	Equation
Analog Output	$\text{Test Limit} = \text{TestValue} \pm [\text{Reading (Gain Error)} + \text{Range (Offset Error)}]$ <ul style="list-style-type: none"> <li>Absolute Accuracy on the analog output channels is determined using the following assumptions: <ul style="list-style-type: none"> <li>Temperature Change from Last External Calibration = 10 °C</li> <li>Temperature Change from Last Internal Calibration = 1 °C</li> </ul> </li> </ul>
Counter Accuracy	$\text{TestLimits} = \text{TestValue} \pm (\text{TestValue} * 50 \text{ ppm})$

### Related concepts:

- [Launching a Calibration Procedure](#)

## Dynamic Signal Acquisition Devices

Calibrate your dynamic signal acquisition devices with Calibration Executive.

### USB-4431/4432 Calibration Procedure

Calibrate the USB-4431/4432 using Calibration Executive.

### Calibration Executive Procedure Features

Verify Only ✓	Verify & Adjust ✓	Manual Mode ✓	Optional Adjust ✗
---------------	-------------------	---------------	-------------------

### Approximate Test Time

38 minutes

### Test Equipment

The following table lists the test instruments required for calibrating the USB-4431/

4432.

**Table 105.** Test equipment for calibrating the USB-4431/4432

Instrument	Recommended Model	Specification	Value
Calibrator	Fluke 5700A	AI AC Coupled Gain, AI DC Coupled Gain, AI Offset	Frequency Range: 1 kHz Voltage Range: up to 9 V <sub>pk</sub> AC Voltage Accuracy: ±0.03% at 1 kHz* DC Voltage Accuracy: ±150 ppm at 9 V ±100 μV with 1 mA load current
Function Generator	Agilent 33250A	Timebase Frequency Accuracy	Frequency Range: up to 10 kHz Frequency Accuracy: ±5 ppm† Voltage Range: up to 9 V <sub>pk</sub>
DMM	NI 4071	AO Gain, AO Offset	DC Voltage Resolution: 1 μV DC Voltage Accuracy at 3.15 V: ±150 ppm
BNC Shorting Cap  (x4 for the USB-4431, x5 for the USB-4432)	Pomona Electronics 5085	AI Offset	Resistance: 1 <1 Ω
BNC Cable (x6)	Pomona Electronics 5697	All	Characteristic Impedance: 50 Ω
BNC (Female) to Banana Adapter	Pomona Electronics 1269	All	—
BNC T-Connector (x4)	Pomona Electronics	AI Gain,	Characteristic Impedance: 50 Ω

Instrument	Recommended Model	Specification	Value
	4896	AI Offset	



## Note

- \*AC accuracy is the sum of all errors, including percent of reading error and temperature error, but excluding percent of range error.
- †Frequency accuracy is the sum of all errors, including initial accuracy and stability errors.

## Test Conditions

The following setup and environmental conditions are required to ensure the NI USB-4431/4432 meets published specifications.

- Keep connections to the device as short as possible. Long cables and wires act as antennas, picking up extra noise that can affect measurements
- Use 50  $\Omega$  BNC coaxial cables for all connections to the device.
- Keep relative humidity between 10% and 80%, noncondensing, or consult the device documentation for the optimum relative humidity.
- Maintain the ambient temperature between 18 °C and 28 °C, or refer to the device specifications for the optimum temperature range.
- Allow a warm-up time of at least 30 minutes to ensure that the measurement circuitry of the NI USB-4431/4432 is at a stable operating temperature.
- Allow a warm-up time for all of the instruments and equipment according to the manufacturer instructions.

## Device Setup

1. Connect the USB-4331/4331 to the host PC.
2. Configure the hardware using Measurement & Automation Explorer (MAX).
3. Launch the Calibration Executive procedure. Calibration Executive guides you through the required connections.



## Test Limit Equations

The following test limits are derived from the published specifications.

**Table 106.** USB-4431/4432 Test Limit Equations

Equation Type	Equation
AI AC and DC Offset	TestLimit = $\pm 1.3$ mV
AI and AO Offset	TestLimit = $\pm 1.3$ mV
AI AC Coupled Gain Accuracy	TestLimit = TestValue * ( $\pm 0.025$ dB)
AI DC Coupled Gain Accuracy	TestLimit = TestValue $\pm$ TestValue * 0.15%
AO Gain	TestLimit = TestValue $\pm$ TestValue * 0.2%
Timebase Frequency Accuracy	TestLimit = TestValue $\pm$ TestValue * 75 ppm

## NI 4461/4462/4465 Calibration Procedure

Calibrate the PXI/PCI-4461/4462 and PXI-4465 using Calibration Executive.

### Calibration Executive Procedure Features

Verify Only ✓	Verify & Adjust ✓	Manual Mode ✓	Optional Adjust ⓧ
---------------	-------------------	---------------	-------------------

### Approximate Test Time

Device	Test Time
4461	15 minutes
4462/4465	17 minutes

## Test Equipment

The following table lists the test equipment required to calibrate the PXI/PCI-4461/4462 and PXI-4465 devices.

**Table 107.** Test equipment for calibrating the PXI/PCI-4461/4462 and PXI-4465

Instrument	Recommended Model	Requirements
Calibrator	Fluke 5700A	<p>If this instrument is unavailable, use a calibrator that meets the following specifications:</p> <ul style="list-style-type: none"> <li>• DC Voltage Range: 1 V, 10 V</li> <li>• DC Accuracy: <math>\pm 300 \mu\text{V}^{*\dagger}</math>, <math>\pm 3 \text{ mV}^{*\dagger}</math></li> </ul>
Function Generator	Agilent 33250A	<p>If this instrument is unavailable, use a function generator that meets the following specifications:</p> <ul style="list-style-type: none"> <li>• Frequency range: 1 kHz to 10 kHz</li> <li>• Frequency accuracy: <math>\pm 2 \text{ ppm}^\dagger</math></li> <li>• Voltage range: <math>9.98 \text{ V}_{\text{pk-pk}}</math></li> </ul>
DMM	NI 4070	<p>Use with NI 4461.</p> <p>If this instrument is unavailable, use a DMM that meets the following specifications:</p> <ul style="list-style-type: none"> <li>• DC Voltage range: 100 mV, 1 V, 10 V</li> <li>• DC accuracy: <math>\pm 100 \text{ ppm}^\dagger</math></li> </ul>
Chassis	PXI-1042, PXI-1042Q	Use with PXI modules.
BNC to BNC Cable	—	Use a $50 \Omega$ coaxial cable for all connections to the NI 446x device.



### Note

- $*300 \mu\text{V}$  on 1 V range,  $\pm 3 \text{ mV}$  on 10 V range.
- $^\dagger$  This specification contains the initial accuracy and any drift due to temperature and time.



**Note** The Calibration Executive procedure runs in automated mode if you use IVI-supported instruments.

## Test Conditions

The following setup and environmental conditions are required to ensure the NI 4461/4462/4465 meets published specifications.

- Keep connections to the device short. Long cables and wires can act as antennas, which can pick up extra noise that might affect measurements.
- Maintain a temperature between 18 °C and 28 °C.
- Keep relative humidity between 10% and 80%, noncondensing.
- Allow a warm-up time of at least 15 minutes to ensure that the measurement circuitry is at a stable operating temperature.
- (PXI) Ensure that the PXI chassis fan speed is set to HIGH, that the fan filters are clean, and that the empty slots contain filler panels.

## Device Setup

To set up and configure NI 446x devices for calibration, complete the following steps:

1. Install the NI 446x in the host computer or PXI chassis as described in the DAQ Getting Started Guide.
2. Configure the NI 446x with Measurement & Automation Explorer (MAX).



**Note** Refer to the NI Dynamic Signal Acquisition Help, for more information about configuration.

3. Launch the Calibration Executive procedure and complete the setup wizard.
4. While the calibration procedure is running, Calibration Executive prompts you for the appropriate connections. Follow the on-screen instructions at each prompt.

## Troubleshooting Guidelines

If the NI 446x device fails after calibration, check the connections and run the Calibration Executive procedure again.

If the Average Reading still fails, contact NI for repair or replacement. If the Average Reading passes, you can change the calibration report to indicate the passing value.



**Note** If you have Microsoft Access 2000 or later, you can also modify the database containing the test results. By default, this database is located in `\Calibration Executive\Databases\Calibration Reports.mdb`.

### Related concepts:

- [Automated Mode Versus Manual Mode](#)
- [Launching a Calibration Procedure](#)

## PXIe-4463 Calibration Procedure

Calibrate the PXIe-4463 using Calibration Executive.

### Calibration Executive Procedure Features

Verify Only ✓	Verify & Adjust ✓	Manual Mode ✓	Optional Adjust ✗
---------------	-------------------	---------------	-------------------

### Approximate Test Time

Verify Only	Verify & Adjust
21 minutes	33 minutes

## Test Equipment

The following table lists the test instruments required for calibrating the PXIe-4463.

**Table 312.** Test equipment for calibrating the PXIe-4463

Instrument	Recommended Model	Specification	Value
DMM	Keysight Technologies 3458A	AO Offset Verification	DC Voltage

Instrument	Recommended Model	Specification	Value
		AO Offset and Gain Adjustment	Input Range: 1 V, 10 V 2 ppm of range, 15 ppm of reading
		AO Gain Verification AO Flatness Verification AO Interchannel Gain Mismatch Verification	AC Voltage Input Range: 0.1 V <sub>rms</sub> , 1 V <sub>rms</sub> , 10 V <sub>rms</sub> Frequency Range: 20 Hz to 22.4 kHz Accuracy: 45 ppm of range, 370 ppm of reading, 160 ppm of reading @ 1 kHz
		AO Current Drive Verification	AC Current Input Range: 0.1 A <sub>rms</sub> Accuracy: 200 ppm of range, 750 ppm of reading Burden Voltage: < 250 V
Frequency Counter*	Keysight Technologies 53220A-010	Timebase Frequency Verification and Adjustment	Resolution: > 10 digits Timebase Accuracy: ±0.2 ppm
Analog Input DSA	PXIe-4464, BNC connectors	AO Noise Verification	Noise: ≤ 0.7 μV <sub>rms</sub>
PXI Express Chassis <sup>†</sup>	PXIe-1082	All Tests	One of the following chassis: <ul style="list-style-type: none"> <li>• PXIe-1082</li> <li>• PXIe-1085</li> <li>• PXIe-1075</li> <li>• PXIe-1065</li> <li>• PXIe-1062Q</li> </ul>
System	PXIe-8135	All Tests	PXI Express controller or MXI Express

Instrument	Recommended Model	Specification	Value
Controller			card
mXLR (F) to BNC (M) Cable†	NI 156789-0R46 or NI 140150-0R46	All Tests (mXLR variant)	Length: ≤ 0.5 m
BNC (M) to BNC (M) Cable (x1)	Pomona Electronics 5697	All Tests (BNC variant)	Length: ≤ 0.5 m
BNC (M) to BNC (M) Cable (x3)	Pomona Electronics 5697	AO Noise Verification	Length: ≤ 0.5 m
BNC (F) to Banana Adapter	Pomona Electronics 1269	AO Offset Verification AO Gain Verification AO Flatness Verification AO Interchannel Gain Mismatch Verification AO Current Drive Verification AO Offset and Gain Adjustment	—
BNC F-M-F Tee Connector (x3)	Pomona Electronics 3285	AO Noise Verification	Characteristic Impedance: 50 Ω



## Note

- \*The Timebase Frequency step requires the Keysight 53220A. Older counter variants are not compatible.
- †You **must** use one of the listed chassis models to reduce noise during calibration.

- ‡Required only for the mXLR variant of the PXIe-4463.

## Test Conditions

The following setup and environmental conditions are required to ensure the PXIe-4463 meets published specifications.

- Keep connections to the device as short as possible. Long cables and wires act as antennas, picking up extra noise that can affect measurements.
- Verify that all connections to the device are secure.
- Maintain an ambient temperature of  $23\text{ °C} \pm 5\text{ °C}$ . The device temperature will be greater than the ambient temperature.
- As-found test limits are valid for a device temperature within  $\pm 5\text{ °C}$  of the last self-calibration.
- Keep relative humidity below 80%.
- Allow a warm-up time of at least 15 minutes to ensure that the measurement circuitry of the PXIe-4463 is at a stable operating temperature.
- Allow a warm-up time for all of the instruments and equipment according to the manufacturer instructions.

## Device Setup

1. Install the hardware as described in the PXIe-4463 Getting Started Guide.
2. Configure the hardware using Measurement & Automation Explorer (MAX).
3. Launch the Calibration Executive procedure. Calibration Executive guides you through the required connections.

## Test Limit Equations

The following test limits are derived from published specifications. Refer to the NI PXIe-4463 Specifications for AO Noise and AO Current Drive values.

Table 262. PXIe-4463 Test Limit Equations

Equation or Limit Type	Equation or Value
AO Offset Limits	<ul style="list-style-type: none"> <li>• 0 dB attenuation <ul style="list-style-type: none"> <li>◦ As-Found: <math>\pm 0.5</math> mV</li> <li>◦ As-Left: <math>\pm 0.22</math> mV</li> </ul> </li> <li>• 17 dB attenuation <ul style="list-style-type: none"> <li>◦ As-Found: <math>\pm 0.3</math> mV</li> <li>◦ As-Left: <math>\pm 0.13</math> mV</li> </ul> </li> <li>• 37 dB attenuation <ul style="list-style-type: none"> <li>◦ As-Found: <math>\pm 0.2</math> mV</li> <li>◦ As-Left: <math>\pm 0.10</math> mV</li> </ul> </li> </ul>
AO Gain Amplitude	<p>Limits are the same for all attenuation values.</p> <ul style="list-style-type: none"> <li>• As-Found: <math>\pm 0.02</math> dB</li> <li>• As-Left: <math>\pm 0.01</math> dB</li> </ul>
Gain Flatness	<p>Differential terminal configuration</p> <ul style="list-style-type: none"> <li>• Frequency: <ul style="list-style-type: none"> <li>◦ 20 Hz: <math>\pm 0.007</math> dB</li> <li>◦ 20 kHz: <math>\pm 0.007</math> dB</li> <li>◦ 22.4 kHz: <math>\pm 0.009</math> dB</li> </ul> </li> </ul> <p>Pseudodifferential terminal configuration</p> <ul style="list-style-type: none"> <li>• Frequency: <ul style="list-style-type: none"> <li>◦ 20 Hz: <math>\pm 0.008</math> dB</li> <li>◦ 20 kHz: <math>\pm 0.008</math> dB</li> <li>◦ 22.4 kHz: <math>\pm 0.010</math> dB</li> </ul> </li> </ul>
Interchannel Mismatch	$\pm 0.03$ dB
Timebase Frequency	<ul style="list-style-type: none"> <li>• As-Found: <math>\pm 0.444</math> Hz</li> <li>• As-Left: <math>\pm 0.338</math> Hz</li> </ul>



## PXIe-4464 Calibration Procedure

Calibrate the PXIe-4464 using Calibration Executive.

### Calibration Executive Procedure Features

Verify Only ✓	Verify & Adjust ✓	Manual Mode ✓	Optional Adjust ✗
---------------	-------------------	---------------	-------------------

### Approximate Test Time

Verify Only	Verify & Adjust
25 minutes	50 minutes

### Test Equipment

The following table lists the test instruments required for calibrating the PXIe-4464.

**Table 312.** Test equipment for calibrating the PXIe-4464

Instrument	Recommended Model	Specification	Value
Calibrator	Fluke 5700A	AI Gain	Frequency Range: 40 Hz to 92.2 kHz  Voltage Range: up to 6.3 V <sub>rms</sub>  ACV Accuracy: <ul style="list-style-type: none"> <li>• 40 Hz: 0.017%</li> <li>• 1 kHz: 0.016%</li> <li>• 20 kHz: 0.017%</li> <li>• 45 kHz: 0.087%</li> <li>• 92.2 kHz: 0.29%</li> </ul>
Function Generator	Keysight (Agilent) 33250A	Timebase Frequency	Frequency Range: p to 90 kHz

Instrument	Recommended Model	Specification	Value
			Frequency Accuracy: 2 ppm  Voltage Range: up to 9 V <sub>pk</sub>
DMM	PXI-4070	IEPE Current	Current Accuracy: 0.9%
BNC Shorting Cap (x4)	Pomona Electronics 5085 or 3840-50	AI Offset	Resistance: ≤50 Ω
BNC F-F-F T-Connector (x3)	Pomona Electronics 3284	AI Gain	Characteristic Impedance: 50 Ω
BNC (F) to Banana Adapter	Pomona Electronics 1269	AI Gain	—
BNC (M) Cable	Pomona Electronics 5697	AI Gain	Characteristic Impedance: 50 Ω
mXLR (F) to BNC (M) Cable (BNC variant: x7mXLR variant: x4)	NI 156789-XX or NI 140150-XX  0R46 (0.46 m)  0R91 (0.91 m)  2R4 (2.4 m)	All	—
BNC F-F Adapter* (x4)	Pomona Electronics 3283	AI Offset	—
PXI Express Chassis	PXIe-1062Q, PXIe-1075	—	Any PXI Express chassis meets requirements.



**Note** \*Required only for the mXLR variant.

## Test Conditions

The following setup and environmental conditions are required to ensure the

PXIe-4464 meets published specifications.

- Keep connections to the device as short as possible. Long cables and wires act as antennas, picking up extra noise that can affect measurements
- Verify that all connections to the device are secure.
- Maintain an ambient temperature of  $23\text{ °C} \pm 5\text{ °C}$ . The device temperature will be greater than the ambient temperature.
- Keep relative humidity below 80%.
- Allow a warm-up time of at least 15 minutes to ensure that the measurement circuitry of the PXIe-4464 is at a stable operating temperature.
- Allow a warm-up time for all of the instruments and equipment according to the manufacturer instructions.

## Device Setup

1. Install the hardware as described in the NI PXIe-4464 Getting Started Guide.
2. Configure the hardware using Measurement & Automation Explorer (MAX).
3. Launch the Calibration Executive procedure. Calibration Executive guides you through the required connections.



**Note** For mXLR variation PXIe-4464 DUTs, an mXLR (F)-to-BNC (M) adapter is needed for each channel, and can be connected before the procedure is run.

Note that the **AI Flatness Verification** step uses measurements recorded in the **AI Gain Accuracy Verification** step as the 1 kHz reference point for flatness calculations for the corresponding gain setting.

## Switch Support and Maintenance

With switches enabled, the PXIe-4464 procedure automatically executes a rudimentary connection test immediately after setup to ensure that all switch paths are correctly connected to their appropriate channels.

To ensure proper operation of the switches used in this procedure, you must periodically test the performance of your switch. Refer to the NI 2503/2529 Switch Performance Test for instructions on validating the performance of the NI 2529 used in this procedure.

This procedure supports automation using an NI 2529 switch matrix. To enable automation, you must make the following connections from the test system to the switch:

- Connect switch channels C0 +/- through C3 +/- to DUT channels 0 +/- through 3 +/-, respectively.
- Connect switch channel R0 +/- to the DMM current +/- terminals.
- Connect switch channel R1 +/- to the calibrator volts +/- terminals.
- Connect switch channel R2 +/- to the function generator +/- terminals.
- Connect a short across switch R3 and terminals.

## Test Limit Equations

The following test limits are derived from the published specifications and apply to the as-found limits for this device.

**Table 262.** PXIe-4464 Test Limit Equations

Equation Type	Equation or Value	
AI Offset	<b>Gain (dB)</b>	<b>AI Offset, <math>V_{pk}</math> (mV)</b>
	30	$\pm 0.1$
	20	$\pm 0.15$
	10	$\pm 0.3$
	0	$\pm 0.9$
	-10	$\pm 3.0$
	-20	$\pm 9.0$
AI Gain	AI Gain = $\pm 0.3$ dB of $V_{rms}$ value	
AI Flatness	Value of flatness coefficients as compared to 1 kHz reference measurement	

Equation Type	Equation or Value															
	<table border="1"> <thead> <tr> <th rowspan="2">Gain (db)</th> <th colspan="3">Frequency</th> </tr> <tr> <th>&gt;30 Hz – 20 kHz</th> <th>&gt;20 kHz – 45 kHz</th> <th>&gt;45 kHz – 92.2 kHz</th> </tr> </thead> <tbody> <tr> <td>0, 10, 20, 30</td> <td>±0.006 dB</td> <td>±0.03 dB</td> <td>±0.1 dB</td> </tr> <tr> <td>-20, -10</td> <td>±0.2 dB</td> <td>±0.6 dB</td> <td>±1 dB</td> </tr> </tbody> </table>	Gain (db)	Frequency			>30 Hz – 20 kHz	>20 kHz – 45 kHz	>45 kHz – 92.2 kHz	0, 10, 20, 30	±0.006 dB	±0.03 dB	±0.1 dB	-20, -10	±0.2 dB	±0.6 dB	±1 dB
Gain (db)	Frequency															
	>30 Hz – 20 kHz	>20 kHz – 45 kHz	>45 kHz – 92.2 kHz													
0, 10, 20, 30	±0.006 dB	±0.03 dB	±0.1 dB													
-20, -10	±0.2 dB	±0.6 dB	±1 dB													
AI Noise	<table border="1"> <thead> <tr> <th>Gain (dB)</th> <th><math>f_s = 51.2 \text{ kS/s}</math> Max (<math>\mu\text{V}_{\text{rms}}</math>)</th> </tr> </thead> <tbody> <tr> <td>30</td> <td>1.4</td> </tr> <tr> <td>20</td> <td>2.0</td> </tr> <tr> <td>10</td> <td>4.7</td> </tr> <tr> <td>0</td> <td>14.0</td> </tr> <tr> <td>-10</td> <td>117</td> </tr> <tr> <td>-20</td> <td>197</td> </tr> </tbody> </table>	Gain (dB)	$f_s = 51.2 \text{ kS/s}$ Max ( $\mu\text{V}_{\text{rms}}$ )	30	1.4	20	2.0	10	4.7	0	14.0	-10	117	-20	197	
Gain (dB)	$f_s = 51.2 \text{ kS/s}$ Max ( $\mu\text{V}_{\text{rms}}$ )															
30	1.4															
20	2.0															
10	4.7															
0	14.0															
-10	117															
-20	197															
IEPE Current	<table border="1"> <thead> <tr> <th>IEPE Current Setting (mA)</th> <th>Min (mA)</th> </tr> </thead> <tbody> <tr> <td>4</td> <td>4.0</td> </tr> <tr> <td>10</td> <td>9.6</td> </tr> <tr> <td>20</td> <td>19.3</td> </tr> </tbody> </table>	IEPE Current Setting (mA)	Min (mA)	4	4.0	10	9.6	20	19.3							
IEPE Current Setting (mA)	Min (mA)															
4	4.0															
10	9.6															
20	19.3															
Timebase Frequency	Timebase Frequency = ±27 ppm of test value															

### Related concepts:

- [NI 2503/2529 Switch Performance Test](#)

## PXIe-4466/4467/4468 Calibration Procedure

Calibrate the PXIe-4466, PXIe-4467, or PXIe-4468 with either BNC or mini-XLR connectors using Calibration Executive.

### Calibration Executive Procedure Features

Verify Only ✓	Adjust Only ✓	Verify & Adjust ✓	Manual Mode ✗	Optional Adjust ✗
---------------	---------------	-------------------	---------------	-------------------

### Approximate Test Time

Warm-up	Verify Only	Adjust Only	Verify & Adjust
15 minutes	20 minutes	5 minutes	45 minutes

### Test Equipment

The following table lists the test equipment required for calibrating PXIe-4466, PXIe-4467, or PXIe-4468.

**Table 312.** Test equipment for calibrating the PXIe-4466, PXIe-4467, or PXIe-4468

Instrument	Recommended Model	Where Used	Functional Requirements
Calibrator	Fluke 5730A	<ul style="list-style-type: none"> <li>AI Gain</li> <li>AI Flatness</li> <li>AI Offset</li> <li>AI/AO Offset and Gain Adjustment</li> </ul>	AC voltage requirements: <ul style="list-style-type: none"> <li>Frequency Range: 40 Hz to 100 kHz</li> <li>Voltage Range: up to 6.3 V<sub>rms</sub></li> </ul> DC voltage: 0 V
Digital Multimeter (DMM)	Keysight (Agilent) 3458A	<ul style="list-style-type: none"> <li>AO Common-Mode Gain</li> <li>AO Common-Mode Offset</li> </ul>	<ul style="list-style-type: none"> <li>DC Voltage Input Range: 100 mV, 1 V, 10 V</li> <li>AC Voltage Input</li> </ul>

Instrument	Recommended Model	Where Used	Functional Requirements
		<ul style="list-style-type: none"> <li>• AO Differential Offset</li> <li>• AO Differential Gain</li> <li>• AO Differential Flatness</li> <li>• IEPE Current</li> </ul>	<ul style="list-style-type: none"> <li>• Range: 1 V<sub>rms</sub>, 10 V<sub>rms</sub></li> <li>• Frequency Range: 20 Hz to 100 kHz</li> <li>• DC Current Input Range: 10 mA, 100 mA</li> </ul>
Function Generator	Keysight (Agilent) 33250A series	<ul style="list-style-type: none"> <li>• Timebase Frequency</li> <li>• Timebase Frequency Adjustment</li> </ul>	Frequency Range: up to 90 kHz
PXI Express Chassis	PXIe-1082 PXIe-1085 PXIe-1075 PXIe-1065 PXIe-1062Q	All Tests	—
System Controller	PXIe-8135	All tests	A PXI Express controller or MXI Express Card
mXLR (F) to BNC (M) Cable	NI 140150-0R46	All tests for devices with mini-XLR connectors	Length: ≤ 0.5m
BNC (M) to BNC (M) Cable	Pomona Electronics 5697	All Tests for devices with BNC connectors	Length: ≤ 0.5m
BNC (F) to Banana Adapter	Pomona Electronics 1269	<ul style="list-style-type: none"> <li>• AI Gain</li> <li>• AI Flatness</li> <li>• AO Offset</li> <li>• AO Gain</li> </ul>	—

Instrument	Recommended Model	Where Used	Functional Requirements
		<ul style="list-style-type: none"> <li>• AO Flatness</li> <li>• AI/AO Offset and Gain Adjustment</li> <li>• AI Offset</li> <li>• IEPE Current</li> <li>• AO Common-Mode Offset</li> <li>• AO Common-Mode Gain</li> </ul>	
Banana to Banana Cable	Pomona Electronics B-4-2	<ul style="list-style-type: none"> <li>• AO Common-Mode Offset</li> <li>• AO Common-Mode Gain</li> </ul>	Length: $\leq 0.5\text{m}$
Banana to Alligator Clip Cable	Pomona Electronics 1166-12-0 (Black) 1166-12-2 (Red)	<ul style="list-style-type: none"> <li>• AO Common-Mode Offset</li> <li>• AO Common-Mode Gain</li> </ul>	Length: $\leq 0.5\text{m}$

## Test Conditions

The following setup and environmental conditions are required to ensure the PXIe-4466, PXIe-4467, or PXIe-4468 meets published specifications.

- Keep connections to the device as short as possible. Long cables and wires act as antennas, picking up extra noise that can affect measurements.
- Verify that all connections to the device are secure.
- Allow a warm-up time for all of the instruments and equipment according to the manufacturer instructions.
- Use shielded copper wire for all cable connections to the device.
- Use twisted-pair wire to eliminate noise and thermal offsets.
- Ensure that the PXI Express chassis fan speed is set to HIGH, that the fan filters are



clean, and that the empty slots contain slot blockers and filler panels. For more information, refer to the Maintain Forced-Air Cooling Note to Users document available at [ni.com/docs](http://ni.com/docs).

## Device Setup

1. Install the hardware as described in the ***PXIe-4466/4467/4468 Getting Started Guide***.
2. Configure the hardware using Measurement & Automation Explorer (MAX).
3. Launch the Calibration Executive procedure. Calibration Executive guides you through the required connections.

### Related information:

- [PXIe-4466/4467/4468 Getting Started Guide](#)

## NI 4472/4474/4472B Calibration Procedure

Calibrate the PXI/PCI-4472/4474/4472B using Calibration Executive.

### Calibration Executive Procedure Features

Verify Only ✓	Verify & Adjust ✓	Manual Mode ✓	Optional Adjust ✗
---------------	-------------------	---------------	-------------------

### Approximate Test Time

Device	Test Time
4472/4472B	12 minutes
4474	10 minutes

### Test Equipment

The following table lists the test equipment required to calibrate PXI/PCI-4472/4474/4472B devices.

**Table 113.** Test equipment for calibrating the PXI/PCI-4472/4474/4472B

Instrument	Recommended Model	Requirements
Calibrator	Fluke 5700A	<p>If this instrument is unavailable, use a calibrator that meets the following specifications:</p> <ul style="list-style-type: none"> <li>• Frequency Range: 20 Hz to 45 kHz</li> <li>• Voltage Range: Up to 5 V<sub>rms</sub></li> <li>• AC Accuracy: <math>\pm 0.1\%</math>*, 20 Hz to 95 kHz</li> <li>• DC Accuracy: <math>\pm 115</math> ppm† at 5 V</li> </ul>
Function Generator	Agilent 33250A	<p>If this instrument is unavailable, use a function generator that meets the following specifications:</p> <ul style="list-style-type: none"> <li>• Frequency range: Up to 10 kHz</li> <li>• Frequency accuracy: <math>\pm 2</math> ppm‡</li> <li>• Voltage range: Up to 9 V<sub>pp</sub></li> </ul>
Chassis	PXI-1042, PXI-1042Q	Use with PXI modules.
T-connectors	—	<p>For the NI 4472/4472B, use 8 T-connectors.</p> <p>For the NI 4474, use 4 T-connectors.</p>
SMB-to-BNC Cables	—	<p>For the NI 4472/4472B, use 8 SMB-to-BNC cables.</p> <p>For the NI 4474, use 4 SMB-to-BNC cables.</p>



### Note

- \*AC accuracy is the sum of all errors, including percent of reading error and temperature error but excluding percent of range error.
- †DC accuracy is the sum of all errors, including percent of reading error, percent of range error, and temperature error.

- ‡Frequency accuracy is the sum of all errors, including initial accuracy and stability errors.



**Note** The Calibration Executive procedure runs in automated mode if you use IVI-supported instruments.

## Test Conditions

The following setup and environmental conditions are required to ensure the PXI/PCI-4472/4474/4472B meets published specifications.

- Keep connections to the device short. Long cables and wires can act as antennas, which can pick up extra noise that might affect measurements.
- Use shielded copper wire for all cable connections to the device. Use twisted-pair wire to eliminate noise and thermal offsets.
- Maintain a temperature between 18 °C and 28 °C.
- Keep relative humidity below 80%.
- Allow a warm-up time of at least 15 minutes to ensure that the measurement circuitry is at a stable operating temperature.
- (PXI) Ensure that the PXI chassis fan speed is set to HIGH, that the fan filters are clean, and that the empty slots contain filler panels.

## Device Setup

To set up and configure NI 4472/4474/4472B devices for calibration, complete the following steps:

1. Install the DSA device in the host computer or PXI chassis as described in the DAQ Getting Started Guide.
2. Configure the DSA device with Measurement & Automation Explorer (MAX).



**Note** Refer to the NI Dynamic Signal Acquisition Help for more information about configuration.

3. Launch the Calibration Executive procedure and complete the setup wizard.

- While the calibration procedure is running, Calibration Executive prompts you for the appropriate connections. Follow the on-screen instructions at each prompt.

## Troubleshooting Guidelines

If the NI 4472/4474/4472B device fails after calibration, check the connections and run the Calibration Executive procedure again.

If the Average Reading still fails, contact NI for repair or replacement. If the Average Reading passes, you can change the calibration report to indicate the passing value.



**Note** If you have Microsoft Access 2000 or later, you can also modify the database containing the test results. By default, this database is located in `\Calibration Executive\Databases\Calibration Reports.mdb`.

### Related concepts:

- [Automated Mode Versus Manual Mode](#)
- [Launching a Calibration Procedure](#)

## NI 4492/4495/4496/4497/4498/4499 Calibration Procedure

Calibrate the PXI/PXIe-4492/4495/4496/4497/4498/4499 using Calibration Executive.

### Calibration Executive Procedure Features

Verify Only ✓	Verify & Adjust ✓	Manual Mode ✓	Optional Adjust ✗
---------------	-------------------	---------------	-------------------

## Approximate Test Time

Table 114. Approximate test times for each device

Device	Test Time
PXIe-4492	75 minutes
NI 4495/4496	60 minutes
4497	120 minutes

Device	Test Time
NI 4498	120 minutes
4499	225 minutes

## Test Equipment

The following table lists the test equipment required to calibrate PXI/PXIe-4492/4495/4496/4497/4498/4499 devices.

**Table 312.** Test equipment for calibrating the PXI/PXIe-4492/4495/4496/4497/4498/4499

Recommended Model	Requirements
Fluke 5700A	<p>If this instrument is unavailable, use a calibrator that meets the following specifications:</p> <ul style="list-style-type: none"> <li>• Frequency Range: 20 Hz to 92.2 kHz</li> <li>• Voltage Range: up to 9 V<sub>pk</sub></li> <li>• AC Accuracy: <math>\pm 0.05\%^*</math>, 20 Hz to 95 kHz</li> <li>• DC Accuracy: <math>\pm 115</math> ppm<sup>†</sup> at 5 V</li> </ul>
NI SHB4X-8BNC	Shielded InfiniBand to BNC cables for NI 449x devices.
—	—
—	50 $\Omega$ terminators.
—	Use a 50 $\Omega$ coaxial cable for all connections to the device.
PXI-1042, PXI-1042Q	Use with PXI modules.
PXIe-1062Q	Use with PXI Express modules.



### Note

- \*AC accuracy is the sum of all errors including percent of reading error

and temperature error but excluding percent of range error.

- † DC accuracy is the sum of all errors including percent of reading error, percent of range error, and temperature error.
- Frequency accuracy is the sum of all errors, including initial accuracy and stability errors.



**Note** The Calibration Executive procedure runs in automated mode if you use IVI-supported instruments.

## Test Conditions

The following setup and environmental conditions are required to ensure the PXI/PXIe-4492/4495/4496/4497/4498/4499 meets published specifications.

- Keep connections to the device short. Long cables and wires can act as antennas, which can pick up extra noise that might affect measurements.
- Maintain a temperature between 18 °C and 28 °C.
- Keep relative humidity between 10 and 80%, noncondensing.
- Allow a warm-up time of at least 15 minutes to ensure that the measurement circuitry is at a stable operating temperature.
- Ensure that the PXI/PXI Express chassis fan speed is set to HIGH, that the fan filters are clean, and that the empty slots contain filler panels.

## Device Setup

To set up and configure NI 449x devices for calibration, complete the following steps:

1. Install the DSA device in the host computer or PXI chassis as described in the DAQ Getting Started Guide.
2. Configure the DSA device with Measurement & Automation Explorer (MAX).



**Note** Refer to the NI Dynamic Signal Acquisition Help for more information about configuration.

3. Launch the Calibration Executive procedure and complete the setup wizard.

- While the calibration procedure is running, Calibration Executive prompts you for the appropriate connections. Follow the on-screen instructions at each prompt.

## Troubleshooting Guidelines

If the NI 449x device fails after adjustment, check the connections and run the Calibration Executive procedure again.

If the Average Reading still fails, contact NI for repair or replacement. If the Average Reading passes, you can change the calibration report to indicate the passing value.



**Note** If you have Microsoft Access 2000 or later, you can also modify the database containing the test results. By default, this database is located in `\Calibration Executive\Databases\Calibration Reports.mdb`.

## Test Limit Equations

The following test limits are derived from the published specifications.

**Table 116.** NI PXI/PXIe-4492 Test Limit Equations

Equation Type	Equation
AI Offset Verification	AC Coupled Measurement Accuracy <ul style="list-style-type: none"> <li>• Offset (residual DC)</li> <li>• TestLimit = <math>\pm 10</math> mV               <ul style="list-style-type: none"> <li>◦ Temperature within 5 °C from last self-calibration</li> </ul> </li> </ul> DC Coupled Measurement Accuracy <ul style="list-style-type: none"> <li>• Offset</li> <li>• TestLimit = <math>\pm 0.500</math> mV               <ul style="list-style-type: none"> <li>◦ Temperature within 5 °C from last self-calibration</li> </ul> </li> </ul>
AI AC Coupled Gain Accuracy Verification	GainAccuracy

Equation Type	Equation
	<ul style="list-style-type: none"> <li>1 kHz input tone.....0.05 dB max                             <ul style="list-style-type: none"> <li>Temperature within 5 °C from last self-calibration</li> </ul> </li> </ul> <p>AC Coupled Gain Limits = <math>10^{(\pm \text{Gain Accuracy} / 20)} * \text{TestValue}</math></p>
AI Flatness Verification	<p>if Frequency Band is 20 Hz to 20 kHz = <math>\pm 0.005</math> dB</p> <p>if Frequency Band is 20 kHz to 45 kHz = <math>\pm 0.016</math> dB</p> <p>if Frequency Band is 45 kHz to 92.2 kHz = <math>\pm 0.08</math> dB</p> <ul style="list-style-type: none"> <li>Flatness Limit = <math>10^{(\pm \text{Flatness (dB)} / 20)}</math> <ul style="list-style-type: none"> <li>Flatness Limits is given as a factor to be multiplied by V1 kHz to find the true test limits for each frequency tested.</li> </ul> </li> </ul>
AI DC Coupled Gain Accuracy Verification	<p>Gain Accuracy.....0.5%</p> <p>DC Coupled Gain Limits = <math>\text{TestValue} \pm (\text{DC Coupled Offset} + \text{Gain Accuracy (\%)} * \text{Test Value})</math></p> <ul style="list-style-type: none"> <li>Temperature within 5 °C from last self-calibration</li> </ul>
Timebase Frequency	<p>TestLimit = <math>\text{TestValue} \pm [\text{TestValue} * \text{Accuracy (ppm)}]</math></p>

**Table 117.** NI PXI/PXIe-4495 Test Limit Equations

Equation Type	Equation
AI Offset Verification	<p>DC Coupled Measurement Accuracy</p> <ul style="list-style-type: none"> <li>Offset</li> <li>TestLimit = <math>\pm 0.500</math> mV</li> </ul>



Equation Type	Equation
	<ul style="list-style-type: none"> <li>◦ Temperature within 5 °C from last self-calibration</li> </ul>
AI AC Coupled Gain Accuracy Verification	
AI Flatness Verification	<p>if Frequency Band is 20 Hz to 20 kHz = ±0.005 dB</p> <p>if Frequency Band is 20 kHz to 45 kHz = ±0.016 dB</p> <p>if Frequency Band is 45 kHz to 92.2 kHz = ±0.08 dB</p> <ul style="list-style-type: none"> <li>• Flatness Limit = <math>10^{(\pm\text{Flatness (dB)}/20)}</math> <ul style="list-style-type: none"> <li>◦ Flatness Limits is given as a factor to be multiplied by V1 kHz to find the true test limits for each frequency tested.</li> </ul> </li> </ul>
AI DC Coupled Gain Accuracy Verification	<p>Gain Accuracy.....0.5%</p> <p>DC Coupled Gain Limits = TestValue ± (DC Coupled Offset + Gain Accuracy (%) * Test Value)</p> <ul style="list-style-type: none"> <li>• Temperature within 5 °C from last self-calibration</li> </ul>
Timebase Frequency	<p>TestLimit = TestValue ± [TestValue * Accuracy (ppm)]</p>

**Table 118.** NI PXI/PXIe-4496 Test Limit Equations

Equation Type	Equation
AI Offset Verification	<p>AC Coupled Measurement Accuracy</p> <ul style="list-style-type: none"> <li>• Offset (residual DC)</li> <li>• TestLimit = ±2 mV <ul style="list-style-type: none"> <li>◦ Temperature within 5 °C from last self-calibration</li> </ul> </li> </ul>

Equation Type	Equation
AI AC Coupled Gain Accuracy Verification	<p>GainAccuracy</p> <ul style="list-style-type: none"> <li>• 1 kHz input tone.....0.1 dB max                             <ul style="list-style-type: none"> <li>◦ Temperature within 5 °C from last self-calibration</li> </ul> </li> </ul> <p>AC Coupled Gain Limits = <math>10^{(\pm \text{Gain Accuracy} / 20)}</math> * TestValue</p>
AI Flatness Verification	<p>if Frequency Band is 20 Hz to 20 kHz = <math>\pm 0.005</math> dB</p> <p>if Frequency Band is 20 kHz to 45 kHz = <math>\pm 0.016</math> dB</p> <p>if Frequency Band is 45 kHz to 92.2 kHz = <math>\pm 0.08</math> dB</p> <ul style="list-style-type: none"> <li>• Flatness Limit = <math>10^{(\pm \text{Flatness (dB)} / 20)}</math> <ul style="list-style-type: none"> <li>◦ Flatness Limits is given as a factor to be multiplied by V1 kHz to find the true test limits for each frequency tested.</li> </ul> </li> </ul>
AI DC Coupled Gain Accuracy Verification	
Timebase Frequency	TestLimit = TestValue $\pm$ [TestValue * Accuracy (ppm)]

**Table 119.** NI PXI/PXIe-4497 Test Limit Equations

Equation Type	Equation
AI Offset Verification	<p>AC Coupled Measurement Accuracy</p> <ul style="list-style-type: none"> <li>• Offset (residual DC)</li> <li>• TestLimit = <math>\pm 10</math> mV                             <ul style="list-style-type: none"> <li>◦ Temperature within 5 °C from last self-calibration</li> </ul> </li> </ul> <p>DC Coupled Measurement Accuracy</p> <ul style="list-style-type: none"> <li>• Offset</li> <li>• TestLimit = <math>\pm 0.500</math> mV</li> </ul>

Equation Type	Equation
	<ul style="list-style-type: none"> <li>◦ Temperature within 5 °C from last self-calibration</li> </ul>
<p>AI AC Coupled Gain Accuracy Verification</p>	<p>GainAccuracy</p> <ul style="list-style-type: none"> <li>• 1 kHz input tone.....0.05 dB max                             <ul style="list-style-type: none"> <li>◦ Temperature within 5 °C from last self-calibration</li> </ul> </li> </ul> <p>AC Coupled Gain Limits = <math>10^{(\pm \text{Gain Accuracy} / 20)} * \text{TestValue}</math></p>
<p>AI Flatness Verification</p>	<p>if Frequency Band is 20 Hz to 20 kHz = <math>\pm 0.005</math> dB</p> <p>if Frequency Band is 20 kHz to 45 kHz = <math>\pm 0.016</math> dB</p> <p>if Frequency Band is 45 kHz to 92.2 kHz = <math>\pm 0.08</math> dB</p> <ul style="list-style-type: none"> <li>• Flatness Limit = <math>10^{(\pm \text{Flatness (dB)} / 20)}</math> <ul style="list-style-type: none"> <li>◦ Flatness Limits is given as a factor to be multiplied by V1 kHz to find the true test limits for each frequency tested.</li> </ul> </li> </ul>
<p>AI DC Coupled Gain Accuracy Verification</p>	<p>Gain Accuracy.....0.5%</p> <p>DC Coupled Gain Limits = <math>\text{TestValue} \pm (\text{DC Coupled Offset} + \text{Gain Accuracy (\%)} * \text{Test Value})</math></p> <ul style="list-style-type: none"> <li>• Temperature within 5 °C from last self-calibration</li> </ul>
<p>Timebase Frequency</p>	<p><math>\text{TestLimit} = \text{TestValue} \pm [\text{TestValue} * \text{Accuracy (ppm)}]</math></p>

**Table 120.** NI PXI/PXIe-4498 Test Limit Equations

Equation Type	Equation
AI Offset Verification	<p>AC Coupled Measurement Accuracy</p> <ul style="list-style-type: none"> <li>• Offset (residual DC)</li> <li>• TestLimit = ±2 mV                             <ul style="list-style-type: none"> <li>◦ Temperature within 5 °C from last self-calibration</li> </ul> </li> </ul>
AI AC Coupled Gain Accuracy Verification	<p>GainAccuracy</p> <ul style="list-style-type: none"> <li>• 1 kHz input tone.....0.1 dB max                             <ul style="list-style-type: none"> <li>◦ Temperature within 5 °C from last self-calibration</li> </ul> </li> </ul> <p>AC Coupled Gain Limits = <math>10^{(\pm \text{Gain Accuracy} / 20)} * \text{TestValue}</math></p>
AI Flatness Verification	<p>if Frequency Band is 20 Hz to 20 kHz = ±0.005 dB</p> <p>if Frequency Band is 20 kHz to 45 kHz = ±0.016 dB</p> <p>if Frequency Band is 45 kHz to 92.2 kHz = ±0.08 dB</p> <ul style="list-style-type: none"> <li>• Flatness Limit = <math>10^{(\pm \text{Flatness (dB)} / 20)}</math> <ul style="list-style-type: none"> <li>◦ Flatness Limits is given as a factor to be multiplied by V1 kHz to find the true test limits for each frequency tested.</li> </ul> </li> </ul>
AI DC Coupled Gain Accuracy Verification	
Timebase Frequency	TestLimit = TestValue ± [TestValue * Accuracy (ppm)]

**Table 121.** NI PXI/PXIe-4499 Test Limit Equations

Equation Type	Equation
AI Offset Verification	AC Coupled Measurement Accuracy

Equation Type	Equation
	<ul style="list-style-type: none"> <li>• Offset (residual DC)</li> <li>• TestLimit = ±10 mV                             <ul style="list-style-type: none"> <li>◦ Temperature within 5 °C from last self-calibration</li> </ul> </li> </ul> <p>DC Coupled Measurement Accuracy</p> <ul style="list-style-type: none"> <li>• Offset</li> <li>• TestLimit = ±0.500 mV                             <ul style="list-style-type: none"> <li>◦ Temperature within 5 °C from last self-calibration</li> </ul> </li> </ul>
<p>AI AC Coupled Gain Accuracy Verification</p>	<p>GainAccuracy</p> <ul style="list-style-type: none"> <li>• 1 kHz input tone.....0.05 dB max                             <ul style="list-style-type: none"> <li>◦ Temperature within 5 °C from last self-calibration</li> </ul> </li> </ul> <p>AC Coupled Gain Limits = <math>10^{(\pm \text{Gain Accuracy} / 20)} * \text{TestValue}</math></p>
<p>AI Flatness Verification</p>	<p>if Frequency Band is 20 Hz to 20 kHz = ±0.005 dB</p> <p>if Frequency Band is 20 kHz to 45 kHz = ±0.016 dB</p> <p>if Frequency Band is 45 kHz to 92.2 kHz = ±0.08 dB</p> <ul style="list-style-type: none"> <li>• Flatness Limit = <math>10^{(\pm \text{Flatness (dB)} / 20)}</math> <ul style="list-style-type: none"> <li>◦ Flatness Limits is given as a factor to be multiplied by V1 kHz to find the true test limits for each frequency tested.</li> </ul> </li> </ul>
<p>AI DC Coupled Gain Accuracy Verification</p>	<p>Gain Accuracy.....0.5%</p> <p>DC Coupled Gain Limits = <math>\text{TestValue} \pm (\text{DC Coupled Offset} + \text{Gain Accuracy (\%)} * \text{Test Value})</math></p>

Equation Type	Equation
	<ul style="list-style-type: none"> <li>Temperature within 5 °C from last self-calibration</li> </ul>
Timebase Frequency	$\text{TestLimit} = \text{TestValue} \pm [\text{TestValue} * \text{Accuracy (ppm)}]$

### Related concepts:

- [Automated Mode Versus Manual Mode](#)
- [Launching a Calibration Procedure](#)

## PXIe-4480/4481 Calibration Procedure

Calibrate the PXIe-4480 and PXIe-4481 using Calibration Executive.

### Calibration Executive Procedure Features

Verify Only ✓	Verify & Adjust ✓	Manual Mode ✓	Optional Adjust ☒
---------------	-------------------	---------------	-------------------

### Approximate Test Time

Device	Warmup	Verify Only	Verify & Adjust
PXIe-4480	15 minutes	20 minutes	35 minutes
PXIe-4481	15 minutes	10 minutes	20 minutes

### Test Equipment

The following table lists the test instruments required for calibrating the PXIe-4480/4481.

**Table 312.** Test equipment for calibrating the PXIe-4480/4481

Instrument	Recommended Model	Specification	Value
Calibrator	Fluke 5700A	AI Gain	Frequency Range: 40 Hz to 200 kHz Voltage Range: up to 6.3 V <sub>rms</sub> ACV Accuracy: <ul style="list-style-type: none"> <li>• 40 Hz: 0.017%</li> <li>• 1 kHz: 0.016%</li> <li>• 20 kHz: 0.017%</li> <li>• 50 kHz: 0.037%</li> <li>• 100 kHz: 0.086%</li> <li>• 200 kHz: 0.32%</li> </ul>
Function Generator	Keysight (Agilent) 33250A series	Timebase Frequency	Frequency Range: up to 90 kHz Frequency Accuracy: 2 ppm Voltage Range: up to 9 V <sub>pk</sub>
Digital Multimeter	PXI-4070	IEPE Current	Current Accuracy: 0.9%
InfiniBand 12X-6BNC Cable	NI SHB12X-6BNC	All	—
BNC shorting cap (x6)	Pomona Electronics 5085 or 3840-50	AI Offset	Resistance: ≤50 Ω
BNC (F)-to-banana plug adapter	Pomona Electronics 1269	AI Gain	—
BNC (M) cable (x11)	Pomona Electronics 5697	AI Gain	Characteristic Impedance: 50 Ω
BNC F-F-F T-connector (x5)	Pomona Electronics 3284	AI Gain	Characteristic Impedance: 50 Ω
Calibration capacitor	Meggitt Endevco 2947C	Charge Gain	1000 pF 1% COG, calibrated to 0.1%
10-32 (M)-to-BNC (M) interface cable*	PCB Piezotronics 002C03	Charge Gain	—



**Note** \*The DMM, calibration capacitor, and 10-32 (M)-to-BNC (M) interface

cable are required only for the PXIe-4480 module.

## Test Conditions

The following setup and environmental conditions are required to ensure the PXIe-4480/4481 meets published specifications.

- Keep connections to the device as short as possible. Long cables and wires act as antennas, picking up extra noise that can affect measurements.
- Verify that all connections to the device are secure.
- Maintain an ambient temperature of  $23\text{ }^{\circ}\text{C} \pm 5\text{ }^{\circ}\text{C}$ . The device temperature will be greater than the ambient temperature.
- As-found test limits are valid for a device temperature within  $\pm 5\text{ }^{\circ}\text{C}$  of the last self-calibration.
- Keep relative humidity below 80%.
- Allow a warm-up time of at least 15 minutes to ensure that the measurement circuitry of the PXIe-4480/4481 is at a stable operating temperature.
- Allow a warm-up time for all of the instruments and equipment according to the manufacturer instructions.

## Device Setup

1. Install the hardware as described in the ***NI PXIe-4480/4481 Getting Started Guide***.
2. Configure the hardware using Measurement & Automation Explorer (MAX).
3. Launch the Calibration Executive procedure. Calibration Executive guides you through the required connections.

## Test Limit Equations

The following test limits are derived from the published specifications.

**Table 123.** PXIe-4480/4481 Test Limit Equations

Equation Type	Equation
Voltage Gain Accuracy	Voltage Gain Accuracy Limits ( $V_{\text{rms}}$ ) = Amplitude



Equation Type	Equation
	$(V_{rms}) \times 10^{\pm(\text{Voltage Gain Amplitude Accuracy (dB)} / 20)}$
Voltage Gain Flatness	Voltage Gain Flatness Limits ( $V_{rms}$ ) = Amplitude ( $V_{rms}$ ) $\times 10^{\pm(\text{Voltage Gain Flatness (dB)} / 20)}$
Charge Gain Accuracy (PXIe-4480 only)	Limits ( $\mu Crms$ ) = Amplitude ( $V_{rms}$ ) $\times$ Capacitance ( $\mu F$ ) <sup>*</sup> $\times 10^{\pm(\text{Charge Gain Accuracy (dB)} / 20)}$  * The capacitance is the actual measured capacitance of the calibration capacitor used for this test.
Timebase Accuracy	Timebase Frequency Limits (Hz) = Timebase Accuracy (ppm) $\times$ Test Value (Hz) / $10^6$

## PXIe-4610 Calibration Procedure

Calibrate the PXIe-4610 using Calibration Executive.

### Calibration Executive Procedure Features

Verify Only ✓	Verify & Adjust ✓	Manual Mode ✗	Optional Adjust ✗
---------------	-------------------	---------------	-------------------

### Approximate Test Time

Verify Only	Verify & Adjust
2.5 minutes	5 minutes

## Test Equipment

The following table lists the test equipment required for calibrating PXIe-4610 modules.

**Table 312.** Test equipment for calibrating the PXIe-4610

Instrument	Recommended Model	Where Used	Requirements
DMM*	PXI-4070	Gain and Residual Offset Verification	Digitizer capable of measuring $\pm 10 V_{pk}$ sine waves at 1 kHz with an amplitude uncertainty of 0.1 dB or less, a linearity error of 100 ppm or less, and an offset measurement uncertainty of 100 $\mu V$ or less.
Function Generator	PXI-4461	Gain and Residual Offset Verification	Function generator capable of sourcing $\pm 10 V_{pk}$ sine waves at 1 kHz with an amplitude uncertainty of 0.1 dB or less and a frequency uncertainty of 1% or less.
PXI Express Chassis	PXIe-1062Q	—	—



**Note** \*Only NI DMMs capable of digitizer mode are supported by Calibration Executive for this procedure.

## Test Conditions

The following setup and environmental conditions are required to ensure the PXIe-4610 meets published specifications.

- Keep connections to the PXIe-4610 as short as possible. Long cables and wires act as antennas, picking up extra noise that can affect measurements.
- Verify that all connections to the PXIe-4610 are secure.
- Use 50  $\Omega$  BNC coaxial cables for all connections to the PXIe-4610 inputs.
- Maintain an ambient temperature of 23  $^{\circ}C \pm 5^{\circ}C$ . The device temperature will be greater than the ambient temperature.
- Keep relative humidity below 90%.
- Allow a warm-up time of at least 15 minutes to ensure that the PXIe-4610 measurement circuitry is at a stable operating temperature.

- Allow adequate warm-up time for all of the instruments and equipment according to the manufacturer instructions.
- Ensure that the PXI/PXI Express chassis fan speed is set to High, that the fan filters are clean, and that the empty slots contain filler panels. For more information, refer to the ***Maintain Forced-Air Cooling Note to Users*** document available at [ni.com/docs](http://ni.com/docs).

## Device Setup

To set up the PXIe-4610 for calibration, complete the following steps:

- Install the PXIe-4610 in the PXI Chassis according to the instructions in the NI PXIe-4610 Getting Started Guide.
- Configure the hardware using Measurement & Automation Explorer (MAX). Refer to the Measurement & Automation Explorer Help for DAQ for more configuration information.
- Launch the Calibration Executive procedure. Calibration Executive guides you through the required connections.

## Test Limit Equations

The following test limits are derived from the published specifications.

**Table 125.** PXIe-4610 Test Limit Equations

Equation Type	Equation
Gain Accuracy Verification	Unadjusted Gain Verification Limit = $20\text{dB} \pm 0.031\text{ dB}$  Adjusted Gain Verification Limit = $20\text{dB} \pm 0.011\text{ dB}$
Residual Offset	Residual Offset Limit = $\pm 1\text{ mV}$

### Related concepts:

- [Launching a Calibration Procedure](#)

# NI Isolated M/S Series Calibration Procedure

Calibrate the NI PXI/PCI-6230, PXI/PCI-6232, PXI/PCI-6233, PXI/PCI-6236, PXI/PCI-6238, PXI/PCI-6239 and PCI-6154 using Calibration Executive.

## Calibration Executive Procedure Features

Verify Only ✓	Verify & Adjust ✓	Manual Mode ✓	Optional Adjust ✗
---------------	-------------------	---------------	-------------------

## Approximate Test Time

10 minutes

## Test Equipment

The following table lists the test equipment required for calibrating NI M/S Series Isolated devices.

**Table 312.** Test equipment for calibrating the NI PXI/PCI-6230, PXI/PCI-6232, PXI/PCI-6233, PXI/PCI-6236, PXI/PCI-6238, PXI/PCI-6239 and PCI-6154

Instrument	Recommended Model	Requirements
Calibrator	Fluke 5700A	If this instrument is unavailable, use a voltage source that is at least 10 ppm accurate for 16-bit voltage input devices.  For 16-bit current input devices, use a current source that is at least 100 ppm accurate.
DMM	NI 4070	If this instrument is unavailable, use a multiranging 6 1/2-digit DMM with an accuracy of 40 ppm.
Counter	Agilent 53131A	If this instrument is unavailable, use a counter with an accuracy of 0.01%.
Resistor	—	(NI 6232/6233/6238/6239 Devices) For counter verification, use any 1 kΩ resistor.
Power Supply	NI 4110	(NI 6238/6239 Devices) For analog output verification, use any 10–30 VDC, 100 mA power supply.

Instrument	Recommended Model	Requirements
		(NI 6232/6233/6238/6239 Devices) For counter verification, use any 5 VDC, 200 mA power supply.
Chassis	PXI-1042, PXI-1042Q	Use with PXI modules.
Low thermal Copper EMF Plug-in Cable	Fluke 5440A-7002	Do not use standard banana cables.
Shielded DAQ Cable	NI DB37M-DB37F-EP, NI SH37F-37M-1	Use with NI 6154, NI 6230, and NI 6236 devices.
	NI SH37F-37M-1	Use with NI 6232, NI 6233, NI 6238 and NI 6239 devices.
DAQ Accessory	NI CB-37F-LP	Low profile terminal block with 37 screw terminals.
	NI CB-37FH	Horizontal DIN-mountable terminal block with 37-pin screw terminals.
	NI CB-37FV	Vertical DIN-mountable terminal block with 37-pin screw terminals.
	NI CB-37F-HVD	37-pin DIN rail screw terminal block, UL Recognized derated to 30 V <sub>rms</sub> , 42.4 V <sub>pk</sub> , or 60 VDC.

## Test Conditions

The following setup and environmental conditions are required to ensure the NI M/S Series Isolated device meets published specifications.

- Keep connections to the device short. Long cables and wires can act as antennas, which can pick up extra noise that might affect measurements.
- Use shielded copper wire for all cable connections to the device. Use twisted-pair wire to eliminate noise and thermal offsets.
- Maintain a temperature between 18 and 28 °C. The device temperature will be greater than the ambient temperature.
- Keep relative humidity below 80%.
- Allow a warm-up time of at least 15 minutes to ensure that the measurement

circuitry of the device is at a stable operating temperature.

- (PXI) Ensure that the PXI chassis fan speed is set to HIGH, that the fan filters are clean, and that the empty slots contain filler panels.

## Device Setup

Configure the isolated M/S Series device in Measurement & Automation Explorer (MAX) to communicate with NI-DAQmx.

1. Power off the computer or chassis that will hold the device, and install the device in an available slot.
2. Power on the computer and launch MAX.
3. Configure the device identifier and select **Self-Test** to ensure that the device is working properly.



**Note** When a device is configured with MAX, it is assigned a device identifier. Each function call uses this identifier to determine which DAQ device to calibrate.

4. Launch the Calibration Executive procedure and complete the setup wizard.

## Related concepts:

- [Launching a Calibration Procedure](#)

## NI R Series Calibration Procedure

Calibrate the NI 7841R/7842R/7845R/7846R/7847R/7851R/7852R/7853R/7854R/7855R/7856R/7857R/7858R using Calibration Executive.

### Calibration Executive Procedure Features

Verify Only ✓	Verify & Adjust ✓	Manual Mode ✓	Optional Adjust ✗
---------------	-------------------	---------------	-------------------

### Approximate Test Time

10 minutes

## Test Equipment

The following table lists the test equipment required for calibrating NI R Series devices.

**Table 312.** Test equipment for calibrating the NI 7841R/7842R/7845R/7846R/7847R/7851R/7852R/7853R/7854R/7855R/7856R/7857R/7858R

Required Instrument	Recommended Model	Requirements
Calibrator	Fluke 5700A	If this instrument is unavailable, use a calibrator that is accurate to 10 ppm.
DMM	NI 4070	If this instrument is unavailable, use a multiranging 6 1/2-digit DMM with an accuracy of 40 ppm.
Counter	Agilent 53131A	If this instrument is unavailable, use a counter that is accurate to 0.01%.
Chassis	PXI-1042, PXI-1042Q	Use with PXI modules.
	PXIe-1062Q	Use with PXI Express modules.
Low thermal Copper EMF Plug-in Cable	Fluke 5440A-7002	Do not use standard banana cables.
DAQ Accessory	NI SCB-68	Shielded I/O connector block with 68 screw terminals for easy signal connection to 68- or 100-pin R Series devices.
	NI CB-68LP, NI CB-68LPR, NI TBX-68	Low-cost termination accessories with 68 screw terminals for easy connection of field I/O signals to 68-pin R Series devices.
Shielded MIO Cable	NI SHC68-68-RMIO	High-performance shielded cable for R Series devices.

## Test Conditions

The following setup and environmental conditions are required to ensure the NI R Series device meets published specifications.

- Keep connections to the R Series device short. Long cables and wires act as antennas, picking up extra noise that can affect measurements.
- Use shielded copper wire for all cable connections to the device. Use twisted-pair

wire to eliminate noise and thermal offsets.

- Maintain an ambient temperature between 18 and 28 °C. The device temperature will be greater than the ambient temperature.
- Keep relative humidity below 80%.
- Allow a warm-up time of at least 15 minutes to ensure that the measurement circuitry of the device is at a stable operating temperature.
- (PXI/PXI Express) Ensure that the PXI/PXI Express chassis fan speed is set to HIGH and that the empty slots contain filler panels. For more information about maintaining adequate air circulation in your PXI/PXI Express chassis, refer to the ***Maintain Forced-Air Cooling Note to Users*** document available at [ni.com/docs](http://ni.com/docs).

## Device Setup

The device must be configured in Measurement & Automation Explorer (MAX) to communicate with NI-RIO.

Complete the following steps to configure the device in MAX.

1. Install the NI RIO driver software.
2. Power off the computer or chassis that will hold the device and install the device in an available slot.
3. Power on the computer or chassis and launch MAX.
4. In the left pane of MAX, expand **Devices and Interfaces»NI-RIO Devices** to locate your device. Note the Resource Name for this device (for example, R100).



**Note** When a RIO device is configured with MAX, it is assigned a Resource Name. This Resource Name is used to communicate with the device during calibration.

5. Launch the Calibration Executive procedure and complete the setup wizard.

## Test Limit Equations

The following test limits are derived from the published specifications.



**Table 128.** NI R Series Test Limit Equations

Equation Type	Equation
Analog Input	$\text{TestLimits} = \text{TestValue} \pm [\text{TestValue} * \text{GainError} (\% \text{ of Reading}) + \text{Offset} (\mu\text{V}) + \text{Noise and Quantization} (\mu\text{V})]$
Analog Output	$\text{TestLimits} = \text{TestValue} \pm [\text{TestValue} * \text{GainError} (\% \text{ of Reading}) + \text{Offset} (\mu\text{V})]$
Counter	$\text{TestLimits} = \text{TestValue} \pm [\text{TestValue} * \text{Accuracy} (\text{ppm})]$

**Related concepts:**

- [Launching a Calibration Procedure](#)

## SC Express DAQ Devices

Calibrate your SC Express DAQ devices with Calibration Executive.

### PXIe-4300 Calibration Procedure

Calibrate the PXIe-4300 using Calibration Executive.

### Calibration Executive Procedure Features

Verify Only ✓	Verify & Adjust ✓	Manual Mode ✓	Optional Adjust ✗
---------------	-------------------	---------------	-------------------

### Approximate Test Time

4 minutes

### Test Equipment

The following table lists the test instruments required for calibrating the PXIe-4300.

**Table 312.** Test equipment for calibrating the PXIe-4300

Instrument	Recommended Model	Requirements
Calibrator	Fluke 5700 A	If this instrument is unavailable, use a high-precision voltage source with an accuracy of at least 10 ppm for adjustment and at least 40 ppm for verification. The source needs an output impedance of less than or equal to 50 $\Omega$ .
PXI Express Chassis	PXIe-1062Q	—
Connection Accessory	TB-4300	Screw terminal accessory (10 V) for the PXIe-4300.

## Test Conditions

The following setup and environmental conditions are required to ensure the PXIe-4300 meets published specifications.

- Keep connections to the device as short as possible. Long cables and wires act as antennas, picking up extra noise that can affect measurements
- Use shielded copper wire for all cable connections to the device. Use twisted-pair wire to eliminate noise and thermal offsets.
- Maintain the ambient temperature between 18 °C and 28 °C.
- For valid test limits, maintain the device temperature within  $\pm 1$  °C from the last self calibration and  $\pm 10$  °C from the last external calibration. The device temperature will be greater than the ambient temperature.
- Keep the relative humidity below 80%.
- Allow at least 15 minutes warm-up time to ensure that the measurement circuitry is at a stable operating temperature.
- Ensure that the PXI Express chassis fan speed is set to HIGH, that the fan filters are clean, and that the empty slots contain filler panels. For more information, refer to the ***Maintain Forced-Air Cooling Note to Users*** document available at [ni.com/docs](http://ni.com/docs).

## Device Setup

1. Install the PXIe-4300 in the PXI Express chassis according to the instructions in the NI SC Express 4300 Installation Guide and Terminal Block Specifications.

2. Configure the hardware using Measurement & Automation Explorer (MAX).
3. Launch the Calibration Executive procedure. Calibration Executive guides you through the required connections.

## Test Limit Equations

The following test limits are derived from the published specifications.

**Table 130.** PXIe-4300 Test Limit Equations

Equation Type	Equation
Analog Input Accuracy	$\text{TestLimit} = \text{TestValue} \pm [(\text{Input} * \text{GainError}) + (\text{Range} * \text{OffsetError}) + \text{NoiseUncertainty}]$ <p>AbsoluteAccuracy is determined making the following assumptions:</p> <ul style="list-style-type: none"> <li>• Temperature change from last external calibration = 10 °C</li> <li>• Temperature change from last internal calibration = 1 °C</li> </ul>

## PXIe-4302/4303/4304/4305 Calibration Procedure

Calibrate the PXIe-4302/4303/4304/4305 using Calibration Executive.

### Calibration Executive Procedure Features

Verify Only ✓	Verify & Adjust ✓	Manual Mode ✓	Optional Adjust ✗
---------------	-------------------	---------------	-------------------

### Approximate Test Time

Warmup	Verify Only	Verify & Adjust
15 minutes	1 minute	2 minutes

## Test Equipment

The following table lists the test instruments required for calibrating the PXIe-4302/4303/4304/4305.

**Table 312.** Test equipment for calibrating the PXIe-4302/4303/4304/4305

Instrument	Recommended Model	Requirements
DMM	PXI-4071	<p>4302/4303</p> <ul style="list-style-type: none"> <li>Use a DMM that has an accuracy of 13 ppm or better when measuring the 10 V range, an accuracy of 30 ppm or better when measuring the 100 mV range, and an offset error of 0.8 <math>\mu\text{V}</math> or better at 0 V.</li> </ul> <p>4304/4305</p> <ul style="list-style-type: none"> <li>Use a DMM that has an accuracy of 32 ppm or better when measuring voltages higher than 10 V, and an accuracy of 2.1 <math>\mu\text{V}</math> or better when measuring 0 V.</li> </ul>
PXI Express Chassis	PXIe-1062Q	If this chassis is unavailable, use another PXI Express chassis, such as the PXIe-1082 or PXIe-1078.
Connection Accessory	<p>TB-4302 (for PXIe-4302/4303)</p> <p>TB-4304 (for PXIe-4304/4305)</p>	—
SMU	PXIe-4139	<p>4302/4303</p> <ul style="list-style-type: none"> <li>Noise (0.1 Hz to 10 Hz, peak to peak) is 60 <math>\mu\text{V}</math> or better at 10 V, and 2 <math>\mu\text{V}</math> or better at 100 mV.</li> </ul> <p>4304/4305</p> <ul style="list-style-type: none"> <li>Noise (0.1 Hz to 10 Hz, peak to peak) is 60 <math>\mu\text{V}</math> or better when outputting voltages higher than 10 V, and 2 <math>\mu\text{V}</math> or better when</li> </ul>

Instrument	Recommended Model	Requirements
		outputting ) V.

## Test Conditions

The following setup and environmental conditions are required to ensure the PXIe-4302/4303/4304/4305 meets published specifications.

- Keep connections to the device as short as possible. Long cables and wires act as antennas, picking up extra noise that can affect measurements
- Verify that all connections to the device are secure.
- Use shielded copper wire for all cable connections to the device. Use twisted-pair wire to eliminate noise and thermal offsets.
- Maintain an ambient temperature of  $23\text{ }^{\circ}\text{C} \pm 5\text{ }^{\circ}\text{C}$ . The device temperature will be greater than the ambient temperature.
- Keep the relative humidity below 80%.
- Allow at least 15 minutes warm-up time to ensure that the measurement circuitry is at a stable operating temperature.
- Ensure that the PXI Express chassis fan speed is set to HIGH, that the fan filters are clean, and that the empty slots contain filler panels. For more information, refer to the ***Maintain Forced-Air Cooling Note to Users*** document available at [ni.com/docs](http://ni.com/docs).

## Device Setup

1. Install the module in the PXI Express chassis according to instructions in the NI PXIe-4302/4303 and TB-4302/4302C User Guide and Terminal Block Specifications or NI PXIe-4304/4305 and TB-4304 User Guide and Terminal Block Specifications.
2. Connect the terminal block to the module according to the instructions in the NI PXIe-4302/4303 and TB-4302/4302C User Guide and Terminal Block Specifications or NI PXIe-4304/4305 and TB-4304 User Guide and Terminal Block Specifications.
3. Configure the hardware using Measurement & Automation Explorer (MAX).
4. Launch the Calibration Executive procedure. Calibration Executive guides you through the required connections.

## Test Limit Equations

The following test limits are derived from the published specifications.

**Table 132.** PXIe-4302/4303 Test Limit Equations

Equation Type	Equation
Voltage Accuracy Verification	$\text{TestLimit} = \text{TestValue} \pm (\text{TestValue} \times \text{GainError} (\%) + \text{OffsetError})$ <ul style="list-style-type: none"> <li>10 V Range: Gain Error = 0.031%, Offset Error = 1262 <math>\mu\text{V}</math></li> <li>100 mV Range: Gain Error = 0.043%, Offset Error = 29 <math>\mu\text{V}</math></li> </ul>

**Table 133.** PXIe-4304/4305 Test Limit Equations

Equation Type	Equation
Voltage Accuracy Verification	$\text{TestLimit} = \text{TestValue} \pm (\text{TestValue} \times \text{GainError} (\%) + \text{OffsetError})$ <ul style="list-style-type: none"> <li>42 V Range: Gain Error = 0.037%, Offset Error = 4.5 mV</li> </ul>

## TB-4302C Calibration Procedure

Calibrate the TB-4302C terminal block using Calibration Executive.

### Calibration Executive Procedure Features

Verify Only ✓	Verify & Adjust ☒	Manual Mode ✓	Optional Adjust ☒
---------------	-------------------	---------------	-------------------

### Approximate Test Time

7 minutes

## Test Equipment

The following table lists the test instruments required for calibrating the TB-4302C.

**Table 134.** Test equipment for calibrating the TB-4302C

Instrument	Recommended Model	Requirements
DMM	PXI-4071	Use a DMM that has an accuracy of 136 ppm or better when measuring 5 $\Omega$ in 4-wire mode.
4-wire Kelvin probe	Keithley 5808	Use a probe capable of measuring Kelvin resistance.

## Test Conditions

The following setup and environmental conditions are required to ensure the TB-4302C meets published specifications.

- Keep connections to the device as short as possible. Long cables and wires act as antennas, picking up extra noise that can affect measurements
- Maintain an ambient temperature of 23 °C  $\pm$ 5 °C. The device temperature will be greater than the ambient temperature.
- Keep the relative humidity below 80%.

## Device Setup

1. Loosen the two jackscrews and remove the cover from the TB-4302C.
2. Launch the Calibration Executive procedure. Calibration Executive guides you through the required connections.

## Test Limit Equations

The following test limits are derived from the published specifications.

**Table 135.** TB-4302C Test Limit Equations

Equation Type	Equation
Shunt Value Accuracy Verification	TestLimit = TestValue $\pm$ [TestValue * (GainError /

Equation Type	Equation
	100)]

## PXIe-4309 Calibration Procedure

Calibrate the PXIe-4309 using Calibration Executive.

### Calibration Executive Procedure Features

Verify Only ✓	Verify & Adjust ✓	Manual Mode ✓	Optional Adjust ⓧ
---------------	-------------------	---------------	-------------------

### Approximate Test Time

Warmup	Verify Only	Verify & Adjust
15 minutes	30 minutes	50 minutes

### Test Equipment

The following table lists the test instruments required for calibrating the PXIe-4309.

**Table 312.** Test equipment for calibrating the PXIe-4309

Instrument	Recommended Model	Requirements
PXI Express Chassis	PXIe-1062Q	If this chassis is unavailable, use another PXI Express chassis, such as PXIe-1082 or PXIe-1078.
Calibrator	Fluke 5700A	Output Range: $\pm 15$ V, $\pm 10$ V, $\pm 1$ V and $\pm 0.1$ V Accuracy: 10 ppm of output ( $\pm 15$ V, $\pm 10$ V, $\pm 1$ V), 20 ppm of output ( $\pm 0.1$ V) Output Impedance: $\leq 50 \Omega$
DMM	PXI-4071 or PXIe-4081	7 1/2-digit DMM, DC Voltage Input Range: 10 V Accuracy: 12 ppm of reading, 0.5 ppm of range
Connection Accessory	CAL-4309 (NI P/N 142336B-01L)	For automated verification use the CAL-4309. For manual verification use the TB-4309 (ST) or TB-4309 (MT). When using these terminal blocks for verification connect only one channel



Instrument	Recommended Model	Requirements
		to the calibrator at a time.
Test Lead Kit	Pomona Model 72928	Low thermal EMF banana-to-banana and banana-to-probe test lead sets.
Shorting Bar	Pomona Model 5145	Low thermal EMF double banana plug shorting bar.



**Note** Every time you connect the CAL-4309 to the DUT during this calibration procedure, wait 10 minutes for thermal EMF to stabilize.

## Test Conditions

The following setup and environmental conditions are required to ensure the PXIe-4309 meets published specifications.

- Keep connections to the device as short as possible. Long cables and wires act as antennas, picking up extra noise that can affect measurements.
- Verify that all connections to the terminal block are secure.
- Use shielded copper wire for all cable connections to the device. Use twisted-pair wire to eliminate noise and thermal offsets.
- Maintain an ambient temperature of  $23\text{ }^{\circ}\text{C} \pm 5\text{ }^{\circ}\text{C}$ . The device temperature will be greater than the ambient temperature.
- Keep the relative humidity below 80%.
- Allow at least 15 minutes warm-up time to ensure that the measurement circuitry is at a stable operating temperature.
- Ensure that the PXI/PXI Express chassis fan speed is set to HIGH, that the fan filters are clean, and that the empty slots contain filler panels. For more information, refer to the Maintain Forced-Air Cooling Note to Users document available at [ni.com/docs](http://ni.com/docs).
- Allow adequate warm-up time for all of the instruments and equipment according to the manufacturer instructions.

## Device Setup

1. Install the module in the PXI/PXI Express chassis according to instructions in the PXIe-4309 and TB-4309 (ST)/TB-4309 (MT) Getting Started Guide and Terminal Block Specifications.
2. Connect the terminal block to the module according to the instructions in the PXIe-4309 and TB-4309 (ST)/TB-4309 (MT) Getting Started Guide and Terminal Block Specifications.
3. Configure the hardware using Measurement & Automation Explorer (MAX).
4. Run Self Calibration on MAX without any wires connected to the board or terminal block.
5. Launch the Calibration Executive procedure. Calibration Executive guides you through the required connections.

## PXIe-4310 Calibration Procedure

Calibrate the PXIe-4310 using Calibration Executive.

### Calibration Executive Procedure Features

Verify Only ✓	Verify & Adjust ✓	Manual Mode ✓	Optional Adjust ✗
---------------	-------------------	---------------	-------------------

### Approximate Test Time

Warmup	Verify Only	Verify & Adjust
15 minutes	1 minute	3 minutes

## Test Equipment

The following table lists the test instruments required for calibrating the PXIe-4310.

**Table 312.** Test equipment for calibrating the PXIe-4310

Instrument	Recommended Model	Requirements
PXI Express Chassis	PXIe-1062Q	If this chassis is unavailable, use another PXI Express chassis, such as PXIe-1082 or PXIe-1078.

Instrument	Recommended Model	Requirements
Calibrator	Fluke 5700A	Output Range: $\pm 10$ V Accuracy: $\geq 15$ ppm Output Impedance: $\leq 50 \Omega$
Connection Accessory	TB-4310 (10V) terminal block (NI P/N: 142840x-01L)	—

## Test Conditions

The following setup and environmental conditions are required to ensure the PXIe-4310 meets published specifications.

- Keep connections to the device as short as possible. Long cables and wires act as antennas, picking up extra noise that can affect measurements.
- Verify that all connections to the terminal block are secure.
- Use shielded copper wire for all cable connections to the device. Use twisted-pair wire to eliminate noise and thermal offsets.
- Maintain an ambient temperature of  $23 \text{ }^\circ\text{C} \pm 5 \text{ }^\circ\text{C}$ . The device temperature will be greater than the ambient temperature.
- Keep the relative humidity below 80%.
- For valid test limits, maintain the device temperature within  $\pm 1 \text{ }^\circ\text{C}$  from the last self-calibration and  $\pm 10 \text{ }^\circ\text{C}$  from the last external calibration.
- Allow at least 15 minutes warm-up time to ensure that the measurement circuitry is at a stable operating temperature.
- Ensure that the PXI/PXI Express chassis fan speed is set to HIGH, that the fan filters are clean, and that the empty slots contain filler panels. For more information, refer to the Maintain Forced-Air Cooling Note to Users document available at [ni.com/docs](http://ni.com/docs).

## Device Setup

1. Install the module in the PXI/PXI Express chassis according to instructions in the PXIe-4310 and TB-4310 (10V)/TB-4310 (600V) Getting Started Guide and Terminal Block Specifications.
2. Connect the terminal block to the module according to the instructions in the PXIe-4310 and TB-4310 (10V)/TB-4310 (600V) Getting Started Guide and Terminal Block Specifications.
3. Configure the hardware using Measurement & Automation Explorer (MAX).

4. Run Self Calibration on MAX without any wires connected to the board or terminal block.
5. Launch the Calibration Executive procedure. Calibration Executive guides you through the required connections.



**Note** The TB-4310 (600 V) cannot be used for verification or adjustment of the PXIe-4310.

## Test Limit Equations

The following test limits are derived from the published specifications.

**Table 138.** PXIe-4310 Test Limit Equations

Equation Type	Equation
Analog Input Voltage/Accuracy Verification	$\text{AbsoluteAccuracy} = \text{Reading} * (\text{GainError}) + \text{Range} * (\text{OffsetError}) + \text{NoiseUncertainty}$ $\text{GainError} = \text{ResidualAIGainError} + \text{GainTempco} * \text{TempChangeFromLastInternalCal} + \text{ReferenceTempco} * (\text{TempChangeFromLastExternalCal})$ $\text{OffsetError} = \text{ResidualAIOffsetError} + \text{OffsetTempco} * \text{TempChangeFromLastInternalCal} + \text{INL\_Error}$ $\text{NoiseUncertainty} = (\text{RandomNoise} * 3) / \sqrt{10000}$ <p>For a coverage factor of 3 sigma and averaging 10000 points.</p>

## PXIe-4322 Calibration Procedure

Calibrate the PXIe-4322 using Calibration Executive.

## Calibration Executive Procedure Features

Verify Only ✓	Verify & Adjust ✓	Manual Mode ✓	Optional Adjust ✗
---------------	-------------------	---------------	-------------------

### Approximate Test Time

15 minutes

### Test Equipment

The following table lists the test instruments required for calibrating the PXIe-4322.

**Table 312.** Test equipment for calibrating the PXIe-4322

Instrument	Recommended Model	Requirements
DMM	Agilent HP 3458A	Use a DMM that can provide both voltage and current measurements. Accuracy in voltage of 165 ppm or better. Accuracy in current of 20 ppm or better.
PXI Express Chassis	PXIe-1062Q	—
Connection Accessory	TB-4322	—

### Test Conditions

The following setup and environmental conditions are required to ensure the PXIe-4322 meets published specifications.

- Keep connections to the device as short as possible. Long cables and wires act as antennas, picking up extra noise that can affect measurements.
- Verify that all connections to the TB-4322 are secure.
- Use shielded copper wire for all cable connections to the device. Use twisted-pairs wire to eliminate noise.

- Maintain the ambient temperature between  $23\text{ }^{\circ}\text{C} \pm 5\text{ }^{\circ}\text{C}$ .
- The PXIe-4322 temperature will be greater than the ambient temperature.
- Keep the relative humidity below 80%.
- Allow a warm-up time of at least 15 minutes to ensure that the PXIe-4322 measurement circuitry is at a stable operating temperature.
- Ensure that the PXI Express chassis fan speed is set to HIGH, that the fan filters are clean, and that the empty slots contain filler panels. For more information, refer to the **Maintain Forced-Air Cooling Note to Users** document available at [ni.com/docs](http://ni.com/docs).

## Device Setup

1. Install the PXIe-4322 in the PXI Express chassis according to the instructions in the NI PXIe-4322 and TB-4322 Installation Guide and Terminal Block Specifications.
2. Configure the hardware using Measurement & Automation Explorer (MAX).
  - a. Remove the exterior cover to expose the individual channel screw terminals as described in the NI PXIe-4322 Calibration Procedure.
  - b. Ensure that the TB-4322 is correctly connected to the PXIe-4322; the terminal block will appear in the MAX Devices list below the PXIe-4322 module.
3. Launch the Calibration Executive procedure. Calibration Executive guides you through the required connections.

## Test Limit Equations

The following test limits are derived from the published specifications.

**Table 140.** PXIe-4322 Test Limit Equations

Equation Type	Equation
Voltage Output Mode Verification	$\text{AbsoluteVoltageAccuracy} = \text{OutputValue} * \text{GainError} + \text{Range} * \text{OffsetError}$ <ul style="list-style-type: none"> <li>• Range = 16 V</li> <li>• GainError (% of Output) = 0.014%</li> <li>• OffsetError (% of Range) = 0.007%</li> <li>• TestValue <math>\pm</math> AbsoluteAccuracy</li> </ul>
Current Output Mode Verification	$\text{AbsoluteVoltageAccuracy} = \text{OutputValue} * \text{GainError} + \text{Range} * \text{OffsetError}$

Equation Type	Equation
	<ul style="list-style-type: none"> <li>• Range = 20 mA</li> <li>• GainError (% of Output) = 0.033%</li> <li>• OffsetError (% of Range) = 0.019%</li> <li>• TestValue <math>\pm</math> AbsoluteAccuracy</li> </ul>

## PXIe-4330/4331 Calibration Procedure

Calibrate the PXIe-4330/4331 devices using Calibration Executive.

### Calibration Executive Procedure Features

Verify Only ✓	Verify & Adjust ✓	Manual Mode ✗	Optional Adjust ✗
---------------	-------------------	---------------	-------------------

### Approximate Test Time

180 minutes

### Test Equipment

The following table lists the test instruments required for calibrating the PXIe-4330/4331.

**Table 312.** Test equipment for calibrating the PXIe-4330/4331

Instrument	Recommended Model	Requirements
Multifunction calibrator	Fluke 5520A or Fluke 5522A	If this instrument is unavailable, use a calibrator that can provide resistance values in the range of 120 $\Omega$ to 1 k $\Omega$ with 0.01 $\Omega$ resolution, an accuracy of 90 ppm or better, automatic lead wire compensation, and 2-wire output compensation.
DMMs (x2)	PXI-4071 or PXIe-4081	If this instrument is unavailable, use multiranging 6 1/2-digit DMMs with a DC voltage accuracy of 40 ppm or better of reading +6 ppm of range for the 10 V and 1 V ranges, and 4-wire resistance measurement capability with resistance accuracy of 80 ppm or better of reading +6 ppm of range for the 100 k $\Omega$

Instrument	Recommended Model	Requirements
		and 1 k $\Omega$ ranges.
PXI Express chassis	PXIe-1062Q	If this chassis is unavailable, use another PXI Express chassis.
Switch modules (x2)	PXIe-2737	4x64 2-wire relay modules.
Calibration accessory	CAL-4330, NI part number 786988-01	To ensure accuracy, the CAL-4330 requires that the calibrator used is the Fluke 5520A/5522A and that both DMMs are PXI-4071 or PXIe-4081 devices.
160-Pin DIN to 160-Pin DIN cable (x2)	SH160DIN-SH160DIN, NI part number 782417-02	Cable for connecting the PXIe-2737 switch modules to the CAL-4330.
PXIe-4330/4331 to CAL-4330 shielded cable	SH96F-96M-CAL4330, NI part number 787003-01	Cable for connecting the DUT to the CAL-4330.
Banana patch cords (x10)	Five Pomona 1440-36-0 (black) banana patch cords, and five Pomona 1440-36-1 (red) banana patch cords.	Banana-to-banana patch cords.



**Note** Although the Fluke 5500 calibrator has specifications matching those named in the PXIe-4330/4331 Calibration Procedure, there are physical interactions of the DUT which cannot properly read resistance values sourced by this calibrator at all test points.



**Note** To ensure accuracy, the CAL-4330 specifically requires use of a Fluke 5520 calibrator and PXI-4071 or PXIe-4081 DMMs.



## Test Conditions

The following setup and environmental conditions are required to ensure the PXIe-4330/4331 meets published specifications.

- Keep connections to the module as short as possible. Long cables and wires act as antennas, picking up extra noise that can affect measurements.
- Use shielded copper wire for all cable connections to the module. Use twisted-pair wire to eliminate noise and thermal offsets.
- Maintain an ambient temperature of  $23\text{ }^{\circ}\text{C} \pm 5\text{ }^{\circ}\text{C}$ .
- Keep relative humidity below 80%.
- Allow a warm-up time of at least 15 minutes to ensure that the measurement circuitry is at a stable operating temperature.
- Ensure that the PXI Express chassis fan speed is set to HIGH, that the fan filters are clean, and that the empty slots contain filler panels. For more information, refer to the ***Maintain Forced-Air Cooling Note to Users*** document available at [ni.com/docs](http://ni.com/docs).
- Warm-up time for test equipment may vary depending on the manufacturer. Refer to the manufacturer's documentation for the equipment for specified warm-up time.
- To meet Fluke 5520A specifications, zero the calibrator every 7 days, or when the calibrator ambient temperature changes by more than  $5\text{ }^{\circ}\text{C}$ . Warm-up time for Fluke 5520A is 30 minutes.

## Device Setup

1. Install the PXIe-4330/4331 in the PXI Express chassis according to the instructions in the NI SC Express 4330/4331 Installation Guide and Terminal Block Specifications.
2. Configure the hardware using Measurement & Automation Explorer (MAX).
3. Launch the Calibration Executive procedure. Calibration Executive guides you through the required connections.



**Note** The Calibration Executive procedure will instruct you to perform an "OHMS ZERO" operation during setup. If either this operation or a full calibrator zero has been performed in the past 12 hours, click **Continue** to

skip this operation. Refer to the calibrator documentation for instructions on how to perform an "OHMS ZERO" operation using calibrator manual controls.

## CAL-4330 Connection Setup

Complete the following steps before running the Calibration Executive procedure.

1. Set up a PXI Express Chassis with the standards pictured below. Depending on the PXI Express Chassis type, the ordering of the slots may differ.

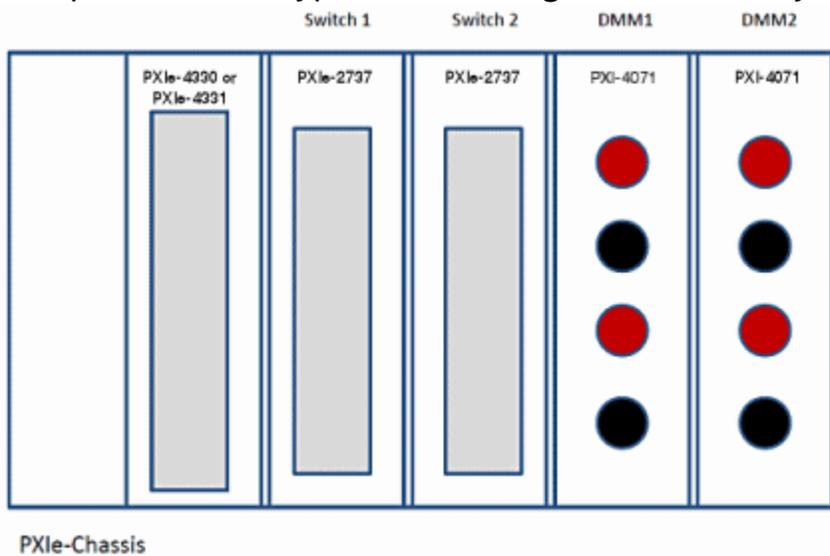

2. Ensure that each module is connected to the appropriate back plane connection (PXI or PXIe), that each instrument is shown in MAX once connected, and that the connection wires are long enough to reach the necessary modules.
3. Connect the PXIe-4330/4331 DUT to the CAL-4330 using the SH96F-96M-CAL4330 cable and standoffs, as shown in the figure below.

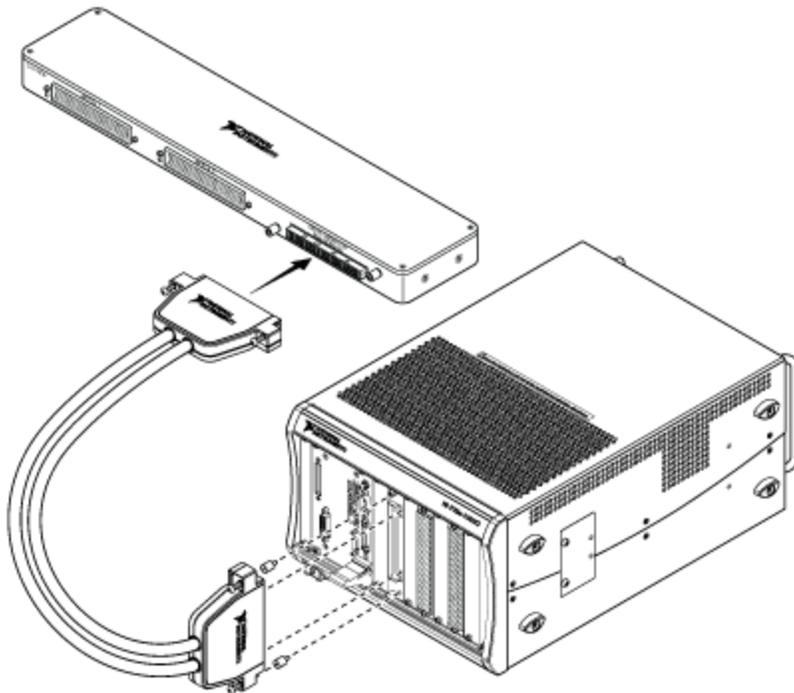

4. Connect the PXle-2737 switch modules to the CAL-4330 using the SH160DIN-SH160DIN cables, as shown in the figure below.

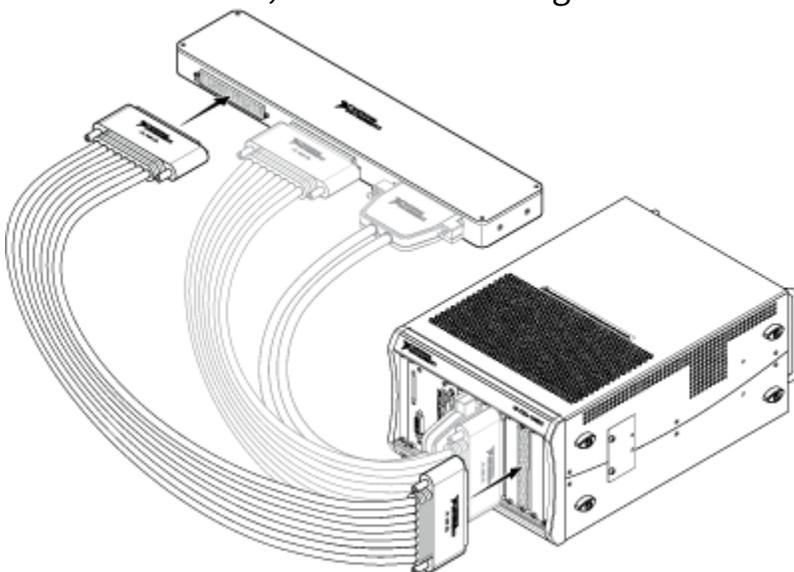

5. Connect the first DMM to the rear panel of the CAL-4330, as shown in the figure below.

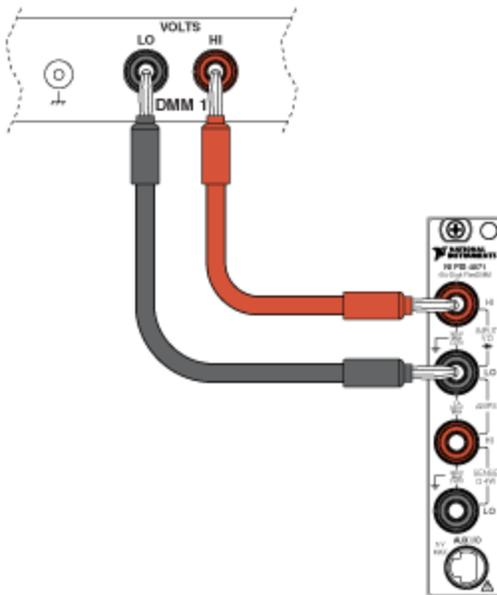

6. Connect the second DMM to the rear panel of the CAL-4330, as shown in the figure below.

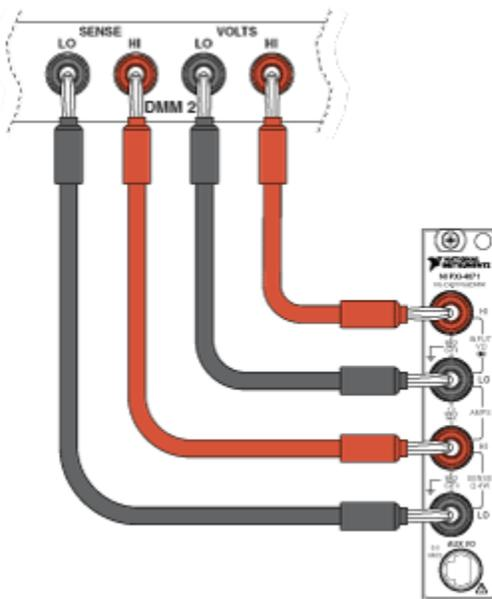

7. After completing either an OHMS ZERO or CAL ZERO operation, connect the calibrator to the rear panel of the CAL-4330, as shown in the figure below. You can connect the calibrator either before starting the Calibration Executive procedure or after the prompt during the procedure setup.

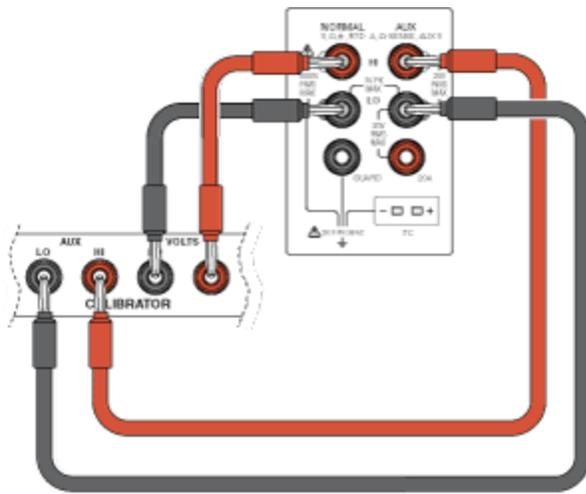

**Note** The wires must be disconnected while running the calibrator zero operation.

8. In the setup wizard for the procedure, select the appropriate DMM resource names for the corresponding connection wires. The PXIe-2737 switch modules are specified at the end of the setup wizard. A pop-up dialog will appear, requesting the switch type and switch module resource name.
9. Select **NI CAL 4330 Switch Fixture** for the switch model name, and select the resource name for the PXIe-2737 based on which connector is connected on the CAL-4330.
10. After selecting the correct locations of the two PXIe-2737 modules, select **Continue**.

## Switch Maintenance

Use the NI Switch Health Center periodically to confirm that the PXIe-2737 switches are operating as expected. The NI Switch Health Center can be found in program files, or you can right-click the PXIe-2737 switch in NI-MAX to access the NI Switch Health Center.

## Legacy Switch Fixture

The legacy switch fixture that uses the NI 2529 switch matrix is no longer recommended for this procedure. If you are still using this fixture, NI recommends that you upgrade to the CAL-4330 fixture and PXIe-2737 switches. However the software still supports this fixture, and you can select that fixture from the selection dialog in the

setup wizard. Contact NI regarding any questions about using the legacy fixture.

## Test Limit Equations

The following test limits are derived from the published specifications.

**Table 142.** PXIe-4330 Test Limit Equations

Equation Type	Equation
Gain Accuracy	$\text{GainAccuracyLimits (V/V)} = \text{NominalValue} \pm (\text{NominalValue} * \text{GainError})$ <p>Sample Rate = 25600 samples/s</p> <ul style="list-style-type: none"> <li>GainError = 0.05%</li> </ul>
Input Offset	$\text{InputOffsetLimits } (\mu\text{V/V}) = 0 \pm \text{OffsetError} / \text{ExcitationVoltage}$ <p>Sample Rate = 25600 samples/s</p> <ul style="list-style-type: none"> <li>Offset Error <ul style="list-style-type: none"> <li>For excitation voltages <math>\leq 2.5</math> V: 168 <math>\mu\text{V/V}</math></li> <li>For excitation voltages <math>&gt; 2.5</math> V: 138 <math>\mu\text{V/V}</math></li> </ul> </li> </ul>
Shunt Quarter Bridge Accuracy	$\text{Limits } (\mu\text{V/V}) = \text{NominalValue} \pm (0.2\% * \text{NominalValue})$ <ul style="list-style-type: none"> <li>QuarterBridgeTolerance = <math>\pm 0.1\%</math></li> </ul> <p>Sample Rate = 25600 samples/s</p>
Shunt Resistance Accuracy	$\text{Limits } (\Omega) = \text{NominalValue} \pm (0.1\% * \text{NominalValue})$ <ul style="list-style-type: none"> <li>ShuntTolerance = <math>\pm 0.1\%</math></li> </ul> <p>Sample Rate = 25600 samples/s</p>
Excitation Voltage	$\text{Limits (V)} = \text{ExcitationVoltageValue} \pm (0.5\% * \text{ExcitationVoltageValue}) \pm 83 \text{ mV}$

Equation Type	Equation
	<ul style="list-style-type: none"> <li>ExcitationVoltageTolerance = <math>\pm 0.5\% \pm 83 \text{ mV}</math></li> </ul> <p>Sample Rate = 25600 samples/s</p>

Table 143. PXIe-4331 Test Limit Equations

Equation Type	Equation
Gain Accuracy	<p>GainAccuracyLimits (V/V) = NominalValue <math>\pm</math> (NominalValue * GainError)</p> <p>Sample Rate = 25600 samples/s</p> <ul style="list-style-type: none"> <li>GainError = 0.05%</li> </ul> <p>Sample Rate = 104200 samples/s</p> <ul style="list-style-type: none"> <li>Gain Error <ul style="list-style-type: none"> <li>For excitation voltage values <math>\leq 2.5 \text{ V}</math>: <math>0.05\% + 0.015\% * (2.5/V_{\text{ex}})</math></li> <li>For excitation voltage values <math>&gt; 2.5 \text{ V}</math>: <math>0.05\% + 0.015\% * (10 \text{ V}/V_{\text{ex}})</math></li> </ul> </li> </ul>
Input Offset	<p>InputOffsetLimits (<math>\mu\text{V}/\text{V}</math>) = <math>0 \pm \text{OffsetError}/\text{ExcitationVoltage}</math></p> <p>Sample Rate = 25600 samples/s</p> <ul style="list-style-type: none"> <li>Offset Error <ul style="list-style-type: none"> <li>For excitation voltages <math>\leq 2.5 \text{ V}</math>: <math>168 \mu\text{V}/\text{V}</math></li> <li>For excitation voltages <math>&gt; 2.5 \text{ V}</math>: <math>138 \mu\text{V}/\text{V}</math></li> </ul> </li> </ul> <p>Sample Rate = 102400 samples/s</p> <ul style="list-style-type: none"> <li>Offset Error <ul style="list-style-type: none"> <li>For excitation voltages <math>\leq 2.5 \text{ V}</math>: <math>198 \mu\text{V}/\text{V}</math></li> <li>For excitation voltages <math>&gt; 2.5 \text{ V}</math>: <math>138 \mu\text{V}/\text{V}</math></li> </ul> </li> </ul>
Shunt Quarter Bridge Accuracy	Limits ( $\mu\text{V}/\text{V}$ ) = NominalValue $\pm$ (0.2% * )

Equation Type	Equation
	NominalValue) <ul style="list-style-type: none"> <li>QuarterBridgeTolerance = <math>\pm 0.1\%</math></li> </ul> Sample Rate = 25600 samples/s
Shunt Resistance Accuracy	Limits ( $\Omega$ ) = $\text{NominalValue} \pm (0.1\% * \text{NominalValue})$ <ul style="list-style-type: none"> <li>ShuntTolerance = <math>\pm 0.1\%</math></li> </ul> Sample Rate = 25600 samples/s
Excitation Voltage	Limits (V) = $\text{ExcitationVoltageValue} \pm (0.5\% * \text{ExcitationVoltageValue}) \pm 83 \text{ mV}$ <ul style="list-style-type: none"> <li>ExcitationVoltageTolerance = <math>\pm 0.5\% \pm 83 \text{ mV}</math></li> </ul> Sample Rate = 25600 samples/s

## PXIe-4339 Calibration Procedure

Calibrate the PXIe-4339 using Calibration Executive.

### Calibration Executive Procedure Features

Verify Only ✓	Verify & Adjust ✓	Manual Mode ✓	Optional Adjust ✗
---------------	-------------------	---------------	-------------------

### Approximate Test Time

Verify Only	Verify & Adjust
23 minutes	43 minutes

### Test Equipment

The following table lists the test equipment required to calibrate the PXIe-4339.



**Table 312.** Test equipment for calibrating the PXIe-4339

Instrument	Recommended Model	Requirements
Calibrator	Fluke 5700	If this instrument is unavailable, use a calibrator that can provide DC voltage values in the range of 0 to $\pm 10$ V with an accuracy of 50 ppm of output or better and a DC offset error of 4 $\mu$ V or better.
PXI Express Chassis	PXIe-1062Q	—
Connection Accessory	TB-4339/B/C*	—



**Note** \*The terminal block variants TB-4339, TB-4339B and TB-4339C differ only in resistance; the measurements are the same regardless of the variant used.

## Test Conditions

The following setup and environmental conditions are required to ensure the PXIe-4339 meets published specifications.

- Keep connections to the device as short as possible. Long cables and wires act as antennas, picking up extra noise that can affect measurements.
- Verify that all connections to the device, including front panel connections, are secure.
- Use shielded copper wire for all cable connections to the device. Use twisted-pair wire to eliminate noise and thermal offsets.
- Maintain an ambient temperature of  $23\text{ }^{\circ}\text{C} \pm 5^{\circ}\text{C}$ . The device temperature will be greater than the ambient temperature.
- Keep relative humidity below 80%.
- Allow a warm up time of at least 15 minutes to ensure that the measurement circuitry is at a stable operating temperature.
- Ensure that the PXI/PXI Express chassis fan speed is set to HIGH, that the fan filters are clean, and that the empty slots contain filler panels. For more information, refer to the **Maintain Forced-Air Cooling Note to Users** document available at [ni.com/docs](http://ni.com/docs).

## Device Setup

1. Install PXIe-4339 in the PXI Express chassis according to the instructions in the NI PXIe-4339 and TB-4339/B/C Installation Guide and Terminal Block Specifications.
2. Configure the device identifier and select **Self-Test** to ensure that the device is working properly.
3. Launch the Calibration Executive procedure. Calibration Executive guides you through the required connections.

## Test Limit Equations

The following test limits are derived from the published specifications.

**Table 145.** PXIe-4339 Test Limit Equations

Equation Type	Equation
Gain and Offset Error Verification and Adjustment	<p>Voltage Mode</p> <ul style="list-style-type: none"> <li>• Limit = Test point * (1 ± Gain Error) ± Offset Error</li> <li>• Gain Error = 0.06%</li> </ul> <p>Ratiometric Mode</p> <ul style="list-style-type: none"> <li>• Limit = Test Point * (1 ± Gain Error) ± Offset Error</li> <li>• Test Point = (Calibrator Output)/(Excitation Voltage)</li> <li>• Gain Error = 0.1%</li> <li>• Offset Error = (Offset Error Coefficient)/(Excitation Voltage)</li> </ul>

Refer to the NI PXIe-4339 Device Specifications for Gain Error and Offset Error values.

## RM-4339 Calibration Procedure

Calibrate the RM-4339 using Calibration Executive.

## Calibration Executive Procedure Features

Verify Only ✓	Verify & Adjust ✗	Manual Mode ✓	Optional Adjust ✗
---------------	-------------------	---------------	-------------------

### Approximate Test Time

60 minutes (verify only)

### Test Equipment

The following table lists the test equipment required to calibrate the RM-4339.

**Table 146.** Test equipment for calibrating the RM-4339

Instrument	Recommended Model	Requirements
Calibrator	Fluke 5520A	If this instrument is unavailable, use a calibrator that can provide resistance values in the range of 120 $\Omega$ to 1 k $\Omega$ with 0.01 $\Omega$ resolution, and an accuracy of 90 ppm or better, and can sink 15 mA on the 120 $\Omega$ setting, 8 mA on the 350 $\Omega$ setting, and 3 mA on the 1 k $\Omega$ setting.
Ohm Meter	PXI-4070	If this instrument is unavailable, use a 6 1/2-digit DMM with 2-wire resistance measurement capability and resistance accuracy of 80 ppm or better of reading +6 ppm of range for the 100 k $\Omega$ range.
8-Channel Universal-Bridge Input Module	PXIe-4339	—
Terminal Block Connection Accessory	TB-4339/B/C*	—
PXI Express Chassis	PXIe-1062Q	—
Accessory Cable	SH96-96-2	The SH96-96-2 is available in 1 meter, 3 meter, and 5 meter lengths. Any of these cable lengths can be used.
RJ50 to	NI P/N:	An RJ50 cable with a cable wire resistance <0.2 $\Omega$ with better than

Instrument	Recommended Model	Requirements
Pigtail Cable (x9)	195950-02	10% resistance mismatch between individual wires.



**Note** \*The terminal block variants TB-4339, TB-4339B, and TB-4339C differ only in resistance; the measurements are the same regardless of the variant used.

## Test Conditions

The following setup and environmental conditions are required to ensure the RM-4339 meets published specifications.

- Keep connections to the RM-4339 as short as possible. Long cables and wires act as antennas, picking up extra noise that can affect measurements.
- Verify that all connections to the device, including front panel connections, are secure.
- Use shielded copper wire for all cable connections to the device. Use twisted-pair wire to eliminate noise and thermal offsets.
- Maintain an ambient temperature of  $23\text{ }^{\circ}\text{C} \pm 5^{\circ}\text{C}$ . The device temperature will be greater than the ambient temperature.



**Note** The temperature variation of the environment should be kept within  $1\text{ }^{\circ}\text{C}$  between measurement of the offset error of the PXIe-4339 and the offset measurement of the RM-4339.

- Keep relative humidity below 80%.
- Allow a warm up time for each of the instruments used in this procedure according to the specific instruments operating instructions.
- Ensure that the PXI/PXI Express chassis fan speed is set to HIGH, that the fan filters are clean, and that the empty slots contain filler panels. For more information, refer to the Maintain Forced-Air Cooling Note to Users document available at [ni.com/docs](http://ni.com/docs).

## Connecting to the RM-4339



**Hazardous Voltage** Make sure the PXI Express chassis is powered off before you insert a module into the chassis.

For information about the required connections for the SCA Shunt Calibration Resistance Accuracy Verification, Offset Voltage Verification, and Quarter-Bridge Shunt Calibration Accuracy Verification procedures, refer to the RM-4339 Calibration Procedure, available at [ni.com/docs](http://ni.com/docs).

To minimize the number of verification connection changes, the connections for SCA Shunt Calibration Resistance Accuracy Verification and Quarter-Bridge Shunt Calibration Accuracy Verification can be made simultaneously.

The TB-4339/B/C terminal block used to short all the AI+ and AI- channels to AIGND should be left connected as in the following diagram to avoid having to wire it up each time you run the procedure.

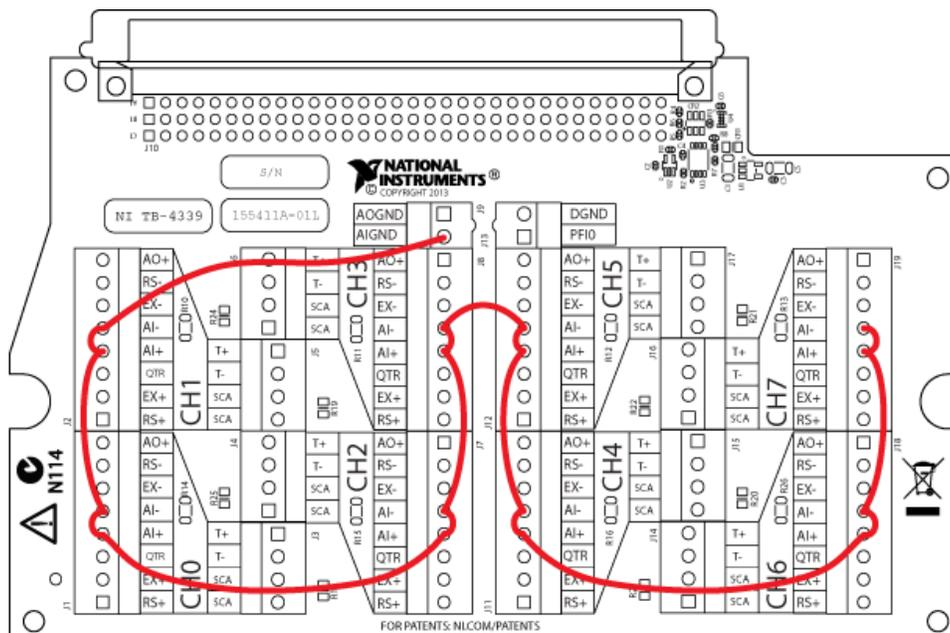

The RM-4339 provides support for up to three PXIe-4339 modules. The 96-pin DIN connectors used to connect the PXIe-4339 to the RM-4339 through the SH96-96-2 cable are located on the rear of the RM-4339 and are labeled A, B, and C. To fully verify the RM-4339, each of the verification procedures in this document must be conducted for each position A, B, and C. Refer to the NI PXIe-4339 and RM-4339 User Guide and

Terminal Block Specifications for information about how to install and use the RM-4339.

## Device Setup

1. Install the RM-4339 according to the instructions in the NI PXIe-4339 and RM-4339 User Guide and Terminal Block Specifications.



**Note** When multiple PXIe-4339 measurement devices are configured, you may have the option to calibrate multiple RM-4339 terminal blocks in a single session. Because only one measurement device can be configured as an instrument for the session, each terminal block must be connected to the selected measurement device during its calibration session.

2. Configure the hardware using Measurement & Automation Explorer (MAX).
3. Launch the Calibration Executive procedure and complete the setup wizard.

Calibration Executive guides you through the connections required for calibration.

## Test Limit Equations

The following test limits are derived from the published specifications.

**Table 147.** RM-4339 Test Limit Equations

Equation Type	Equation
SCA Shunt Calibration Resistance Accuracy Verification	Limits = Nominal Value * (1 ± 0.1%)
Offset Voltage Verification	Limits = Test Point ± 10 µV
Quarter-Bridge Shunt Calibration Accuracy Verification	<p>120 Ω quarter completion tolerance = 0.25%</p> <p>350 Ω and 1 kΩ quarter completion tolerance = 0.15%</p> <p>50 Ω and 100 kΩ quarter bridge shunt calibration resistor tolerance = 0.1%</p>

Equation Type	Equation
	<ul style="list-style-type: none"> <li>• Therefore:</li> <li>• 120 Ω shunt cal accuracy = 0.25% + 0.1% = 0.35%</li> <li>• 350 Ω shunt cal accuracy = 0.15% + 0.1% = 0.25%</li> <li>• 50 Ω shunt cal accuracy = 0.15% + 0.1% = 0.25%</li> </ul>
Equations	<p>The limits for each quarter bridge configuration are calculated as such:</p> <ul style="list-style-type: none"> <li>• 120 Ω Limit (V/V) = Nominal Value * (1 ± 0.35%)</li> <li>• 350 Ω Limit (V/V) = Nominal Value * (1 ± 0.25%)</li> <li>• 1 kΩ Limit (V/V) = Nominal Value * (1 ± 0.25%)</li> </ul>

**Related concepts:**

- [Launching a Calibration Procedure](#)

**PXIe-4353 Calibration Procedure**

Calibrate the PXIe-4353 using Calibration Executive.

**Calibration Executive Procedure Features**

Verify Only ✓	Verify & Adjust ✓	Manual Mode ✓	Optional Adjust ✗
---------------	-------------------	---------------	-------------------

## Approximate Test Time

45 minutes

## Test Equipment

The following table lists the test equipment required to calibrate the PXIe-4353 device.

**Table 312.** Test equipment for calibrating the PXIe-4353

Instrument	Recommended Model	Requirements
Voltage calibrator	Fluke 5520A	If this instrument is unavailable for voltage accuracy verification and adjustment, use a high-precision voltage source with an accuracy of at least 70 ppm when sourcing up to 50 $\mu$ A.
Resistance calibrator*	Fluke 5520A	If this instrument is unavailable for resistance accuracy verification and adjustment, use a high-precision resistance source with an accuracy of at least 150 ppm 2-wire compensation.
PXI Express chassis	PXIe-1062Q	—
Calibration accessory	CAL-4353	This accessory is used for module verification and adjustment.
Connecting wires	Banana-jack terminated copper wire	Copper wire is used for validating the voltage accuracy and adjustment of the analog input channels. Copper wire is also used for validating the resistance accuracy and calibration of the CJC resistance input channels.



**Note** \*When connecting the resistance calibrator, keep the lead wires 1.0  $\Omega$  less than the maximum lead compensation specification of the resistance calibrator. When using the Fluke 5520A, keep the lead wires <1.1  $\Omega$ .



**Note** Though the Fluke 5500 has specifications matching those named in the PXIe-4353 Calibration Procedure, there are physical interactions of the DUT which cannot properly read resistance values sourced by this calibrator at all test points.



## Test Conditions

The following setup and environmental conditions are required to ensure the PXIe-4353 meets published specifications.

- Keep connections to the PXIe-4353 device as short as possible. Long cables and wires act as antennas, picking up extra noise that can affect measurements.
- Use shielded copper wire for all cable connections to the device. Use twisted-pair wire to eliminate noise and thermal offsets.
- Maintain an ambient temperature of  $23\text{ }^{\circ}\text{C} \pm 5\text{ }^{\circ}\text{C}$ . The module temperature will be greater than the ambient temperature.
- Keep relative humidity below 80%.
- Allow a warm-up time of at 15 minutes to ensure that the measurement circuitry of the PXIe-4353 and CAL-4353 are at a stable operating temperature.



**Note** If you are using the Fluke 5520A, allow the calibrator to warm up for 30 minutes and maintain an ambient temperature of  $23\text{ }^{\circ}\text{C} \pm 3\text{ }^{\circ}\text{C}$ . Refer to the Fluke 5520A user manual for the latest set up requirements and recommendations to achieve the best accuracy.

- Temperature change affects the measurement characteristics of an instrument. To take these changes into account, the tested specifications include the effects of temperature drift. For the PXIe-4353, valid temperature drift is  $\pm 10\text{ }^{\circ}\text{C}$ .
- Ensure that the PXI Express chassis fan speed is set to HIGH, that the fan filters are clean, and that the empty slots contain filler panels.

## Device Setup

To set up the PXIe-4353 for calibration, complete the following steps:

1. Install and configure the PXIe-4353 module with Measurement & Automation Explorer (MAX). Refer to the ***Measurement & Automation Explorer Help for DAQ*** for more configuration information.
2. Attach the CAL-4353 to the PXIe-4353 so that the connection pane is flush with the chassis and tighten the connection screw. Ensure the connection between the two devices is stable by confirming that MAX shows the CAL-4353 in the PXIe-4353 device drop down list.

3. Launch the Calibration Executive procedure. Calibration Executive guides you through the required connections.

## Test Limit Equations

The following test limit is derived from published specifications.

**Table 149.** PXIe-4353 Test Limit Equations

Equation Type	Equation
Analog Input Voltage	$\text{VoltageAccuracyLimit} = \text{TestValue} \pm ((\text{TestValue} * \text{GainPercent for Timing Mode}) + (\text{Offset Value for Timing Mode}))$ <ul style="list-style-type: none"> <li>• Gain Errors <ul style="list-style-type: none"> <li>◦ Timing Modes 1–4: 0.04%</li> <li>◦ Timing Modes 5–7: 0.05%</li> </ul> </li> <li>• Offset Values <ul style="list-style-type: none"> <li>◦ Timing Modes 1-3: 2.00E-06</li> <li>◦ Timing Mode 4: 3.00E-06</li> <li>◦ Timing Mode 5: 5.00E-06</li> <li>◦ Timing Mode 6: 6.50E-06</li> <li>◦ Timing Mode 7: 7.70E-06</li> </ul> </li> </ul>
Analog Input Offset	$\text{OffsetLimit} = \text{TestValue} \pm \text{Offset Value for Timing Mode}$ <ul style="list-style-type: none"> <li>• Offset Values <ul style="list-style-type: none"> <li>◦ Timing Modes 1-3: 2.00E-06</li> <li>◦ Timing Mode 4: 3.00E-06</li> <li>◦ Timing Mode 5: 5.00E-06</li> <li>◦ Timing Mode 6: 6.50E-06</li> <li>◦ Timing Mode 7: 7.70E-06</li> </ul> </li> </ul>
CJC Resistance Accuracy	Limits for this test are taken directly from the calibration procedure document.

## TC-4353 Calibration Procedure

Calibrate the TC-4353 using Calibration Executive.

### Calibration Executive Procedure Features

Verify Only ✓	Verify & Adjust ⓧ	Manual Mode ✓	Optional Adjust ⓧ
---------------	-------------------	---------------	-------------------

### Approximate Test Time

15 minutes

### Test Equipment

The following table lists the test equipment required to calibrate the TC-4353 device.

**Table 150.** Test equipment for calibrating the TC-4353

Instrument	Recommended Model	Requirements
Thermocouple Calibrator	Ectron 1140A	If this instrument is unavailable, use a precision thermocouple source with an accuracy of at least 0.07 °C and an output impedance of $\leq 10 \Omega$
PXI Express Chassis	PXIe-1062Q	—
Calibrated PXIe-4353 Module	PXIe-4353	The module must be verified to be within its specifications

The following table lists the fixture equipment required to build your own fixture.

Instrument	Recommended Model	Requirements
Thermocouple Wire	TT-E-24-SLE-100	E-type SLE 24 AWG, 20 to 30 meters
Thermocouple Connector	Omega P/N: SMPW-E-M	E-type, must fit the output terminal of the thermocouple calibrator
Thermocouple	Omega P/N: SMPW-E-M	E-type, mini thermocouple connector to fit the

Instrument	Recommended Model	Requirements
Connector	(x33)	terminals of the TC-4353
Thermocouple Barrier Strips	Omega P/N: BS16A (x4)	32 channels
Thermocouple Barrier Strip Jackets	Omega P/N: BSJ-E (x6)	E-type, 32 channels
Thermocouple Spade Lugs	Omega P/N: SLCH-20 (x4), SLCO-20 (x4)	64 lugs of Chromel, 64 lugs of Constantan to match the E-type wires
Spade-Lug Crimping Tool	Omega P/N: CRIMPING TOOL-P	Must effectively crimp the spade lugs with the 24 AWG wire

## Test Conditions

The following setup and environmental conditions are required to ensure the TC-4353 meets published specifications.

- Keep connections to the PXIe-4353 device as short as possible. Long cables and wires act as antennas, picking up extra noise that can affect measurements.
- Verify that all connections to the PXIe-4353 are secure.
- Maintain an ambient temperature of  $23\text{ °C} \pm 5\text{ °C}$ . The module temperature will be greater than the ambient temperature.
- Keep relative humidity below 80%.
- Allow a warm-up time of at 15 minutes to ensure that the measurement circuitry of the PXIe-4353 and TC-4353 measurement circuitry are at a stable operating temperature.
- Ensure that the PXI Express chassis fan speed is set to HIGH, that the fan filters are clean, and that the empty slots contain filler panels. For more information, refer to the ***Maintain Forced-Air Cooling Note to Users*** document available at [ni.com/docs](http://ni.com/docs).
- To correctly verify the TC-4353, the PXIe-4353 must be currently verified to be within the product specifications. If they are not, verify the PXIe-4353 before verifying the TC-4353. Refer to the ***NI PXIe-4353 Calibration Procedure*** to verify the PXIe-4353 as needed.

Refer to the ***NI TC-4353 Calibration Procedure*** for instructions on building your

own fixture for the TC-4353. Visit [ni.com/calibration](http://ni.com/calibration) to find the calibration procedure.

## Test Limit Equations

The following test limit is derived from published specifications.

**Table 151.** TC-4353 Test Limit Equations

Equation Type	Equation
Accuracy	$\text{AccuracyLimit} = \text{TC-4353 CJC Sensor Accuracy} + \text{PXIe-4353 CJC Channel Accuracy}$ <ul style="list-style-type: none"> <li>• TC-4353 CJC Sensor Accuracy = 0.25 °C</li> <li>• PXIe-4353 CJC Channel Accuracy = 0.03 °C</li> </ul>

## PXIe-4357 Calibration Procedure

Calibrate PXIe-4357 SC Express modules using Calibration Executive.

### Calibration Executive Procedure Features

Verify Only ✓	Verify & Adjust ✓	Manual Mode ✓	Optional Adjust ⓧ
---------------	-------------------	---------------	-------------------

### Approximate Test Time

Verify Only	Verify & Adjust
25 minutes	60 minutes

## Test Equipment

The following table lists the test equipment required for calibrating PXIe-4357 modules.

**Table 312.** Test equipment for calibrating the PXIe-4357

Instrument	Recommended Model	Requirements
Calibrator	Fluke 5520A	Use a calibrator that can provide resistance values in the range of 0 $\Omega$ to 400 $\Omega$ with 0.01 $\Omega$ resolution, an accuracy of 90 ppm or better, and automatic lead-wire compensation.
PXI Express Chassis	PXIe-1062Q	—
Connection Accessory	TB-4357 terminal block	Screw terminal accessory for the PXIe-4357.

## Test Conditions

The following setup and environmental conditions are required to ensure the PXIe-4357 meets published specifications.

- Keep connections to the module as short as possible. Long cables and wires act as antennas, picking up extra noise that can affect measurements.
- Use shielded copper wire for all cable connections to the module. Use twisted-pair wire to eliminate noise and thermal offsets.
- Maintain an ambient temperature of  $23 \pm 5$  °C.
- Keep relative humidity below 80%.
- Allow a warm-up time of at least 15 minutes to ensure that the measurement circuitry of the module is at a stable operating temperature.
- Ensure that the PXI Express chassis fan speed is set to HIGH, that the fan filters are clean, and that the empty slots contain filler panels. For more information, refer to the ***Maintain Forced-Air Cooling Note to Users*** document available at [ni.com/docs](http://ni.com/docs).

## Device Setup

1. Ensure that the PXI Express chassis is turned off.
2. Insert the module into an available slot in the PXI Express chassis.
3. Install the terminal block.
4. Power on the chassis.
5. Launch Measurement & Automation Explorer (MAX).

6. Expand **Devices and Interfaces** to confirm that MAX detects the module.
7. Right-click the module name, and select **Self-Test** to ensure that the device is working properly.

The calibration procedure for the PXIe-4357 requires that you perform an Ohms Zero operation on the calibrator during setup.

## Test Limit Equations

The following test limits are derived from the published specifications.

**Table 153.** PXIe-4357 Test Limit Equations

Equation Type	Equation
Accuracy	$\text{TestLimits} = \text{TestValue} \pm (\text{TestValue} * \text{Gain Error} + \text{Offset Error})$ <ul style="list-style-type: none"> <li>• Offset: 0.034Ω</li> <li>• Gain: 0.04%</li> </ul>

### Related concepts:

- [Performing an Ohms Zero Operation on a Fluke 5520A/5522A Calibrator](#)

## Performing an Ohms Zero Operation on a Fluke 5520A/5522A Calibrator

Some calibrator models require you to perform an Ohms Zero operation to ensure that the resistance output meets the calibrator specifications. Refer to the calibrator documentation for details on performing an Ohms Zero operation and for the maximum interval between Ohms Zero operations. An Ohms Zero operation is typically performed manually by the user.

Complete the following steps to perform an Ohms Zero operation on the Fluke 5520A and Fluke 5522A calibrators.

1. Turn on the calibrator, and allow a warm-up period of at least 30 minutes.
2. Press the **RESET** key.
3. Press the **SETUP** key to open the Setup menu.

4. To display the Calibration information menu, press **CAL**.
5. To display the Calibration Activity menu, press **CAL**.
6. To completely zero the 5520A calibrator, press **ZERO**. To zero only the ohms function, press **OHMS ZERO**.
7. After the ZERO routine is complete (several minutes), press the **RESET** key to reset the calibrator.

## Modular Instruments

Calibrate your Modular Instruments with Calibration Executive.

### Digital Multimeters (DMMs)

Calibrate your DMMs with Calibration Executive.

### NI 4065 Calibration Procedure

Calibrate the PXI/PCI/PCIe/USB-4065 using Calibration Executive.

### Calibration Executive Procedure Features

Verify Only ✓	Verify & Adjust ✓	Manual Mode ✓	Optional Adjust ✗
---------------	-------------------	---------------	-------------------

### Approximate Test Time

75 minutes



**Note** For a list of the TestLimits used in this calibration procedure, refer to the NI 4065 6-½ Digit DMM Calibration Procedure, available at [ni.com/docs](http://ni.com/docs) or [ni.com/calibration](http://ni.com/calibration).

### Test Equipment

The following table lists the test equipment required to calibrate the PXI/PCI/PCIe/USB-4065.



**Table 154.** Test equipment for calibrating the PXI/PCI/PCIe/USB-4065

Instrument	Recommended Model	Requirements
Calibrator	Fluke 5700A/5720A/5730A*	You must use a Fluke 5700A/5720A/5730A to calibrate NI 4065 modules. Do not use a Fluke 5500A/5520A/5522A calibrator.  The Fluke 5700A multifunction calibrator must be within the 90 day calibration interval. The Fluke 5720A/5730A multifunction calibrator must be within the one year calibration interval.
Cables	Fluke 5440 low thermal electromotive force (EMF) copper cables	Use two sets of low thermal electromotive force (EMF) copper cables.
Shorting Bar	Pomona 5145 insulated double banana plug shorting bar	Use to create a short with low thermal EMF ( $\leq 150$ nV) across the HI and LO input banana plug connectors on the NI 4065.
Chassis	(NI PCI/PCIe-4065) A personal computer (PC) with an available PCI slot or an available x1, x4, x8, or x16 PCI Express slot  or  (PXI-4065) NI PXI chassis such as the PXI-1042 or the PXI-1042Q and a PXI controller	—



**Note** \*The Calibration Executive driver defaults to the Fluke 5725A Amplifier for values  $>1.9$  A.

## Test Conditions

The following setup and environmental conditions are required to ensure the PXI/PCI/PCIe/USB-4065 meets published specifications.

- (PXI) Ensure that the PXI chassis fan speed is set to HIGH and the fan filters are

clean.

- Use PXI/PCI filler panels in all vacant slots to allow proper cooling.
- Plug the PXI chassis or PC and the calibrator into the same power strip to avoid ground loops.
- Power on and warm up the calibrator for at least 60 minutes before beginning this calibration procedure, and power on and warm up the NI 4065 for at least 30 minutes before beginning this calibration procedure.
- Maintain an ambient temperature of  $23 \pm 1$  °C.
- Maintain an ambient relative humidity of less than 60%.
- Keep a shorting bar connected between the V GUARD and GROUND binding posts of the calibrator at all times.
- Clean any oxidation from the banana plugs on the Fluke 5440 cables before plugging them into the binding posts of the calibrator or the banana plug connectors of the NI 4065. Oxidation tarnishes the copper banana plugs so they appear dull rather than shiny and leads to greater thermal EMF.
- Keep the blue banana plugs on the Fluke 5440 cables connected to the V GUARD binding post of the calibrator at all times.
- Prevent the cables from moving or vibrating by taping or strapping them to a nonvibrating surface. Movement or vibration causes triboelectric effects that can result in measurement errors.

## Device Setup



**Hazardous Voltage** Voltages as high as 300 V can occur during this procedure. Do not touch the calibrator connections during voltage output.

To set up the PXI/PCI/PCIe/USB-4065 for calibration, complete the following steps:

1. Install the NI 4065 according to the instructions in the NI Digital Multimeters Getting Started Guide.
2. Configure the hardware using Measurement & Automation Explorer (MAX).
3. Launch the Calibration Executive procedure and complete the setup wizard.

Calibration Executive guides you through the connections required for calibration.



**Note** If the NI 4065 fails after calibration, refer to the ***Troubleshooting***

**Guidelines.** If the device still fails after you complete the troubleshooting procedures, return it to NI for repair or replacement.

## Troubleshooting Guidelines

### Error Code –300300

NI-DMM version 2.7.0 is not compatible with Calibration Executive. You must install NI-DMM 2.7.1 or later to run Calibration Executive.

### Error Code –18002

You will receive the following error message if NI-DMM 2.5.1 or earlier is installed.

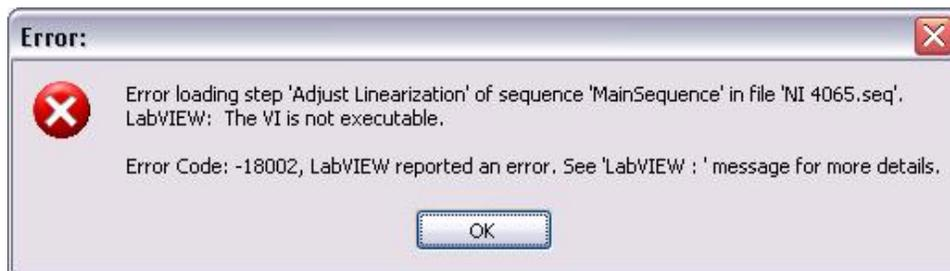

You must install NI-DMM 2.7.1 or later.

## Other Issues

If the PXI/PCI/PCIe/USB-4065 is not recognized in MAX, make sure you followed the configuration guidelines. If MAX fails to recognize the PXI/PCI/PCIe/USB-4065 after you reconfigure, contact NI technical support.

If the PXI/PCI/PCIe/USB-4065 fails after calibration, try the following:

1. Check the connections and run the Calibration Executive procedure again.
2. If the calibration still fails after trying step 1, try verifying the failed Test Points using the DMM Soft Front Panel (SFP), which is located at **Start » All Programs » National Instruments » NI-DMM » NI-DMM Soft Front Panel**. For example, if the analog input (AI) failed at 10.00 VDC, input that value from the calibrator.
  - a. Launch the DMM SFP.
  - b. Using the controls on the DMM SFP, select the appropriate mode and range as

follows:

- **mode:** V DC
- **range:** 10.00 V

3. Check the reading on the display.

If the reading falls outside the range of limits shown in the calibration report after you complete steps 1 and 2, contact NI for repair or replacement. If the reading falls within the limits, you can change the calibration report to indicate the passing value.



**Note** If you have Microsoft Access 2000 or later installed on the computer, you can also modify the database containing the test results. By default, this database is located in `Program Files\National Instruments\CalibrationExecutive\Databases\Calibration Reports.mdb`.

## Test Limit Equations

**Table 155.** NI 4065 Test Limit Equations

Equation Type	Equation
DC Voltage	$\text{TestLimits} = \text{TestValue} \pm (\text{TestValue} * \text{ppm of reading} + \text{DMM Range} * \text{ppm of range})$
DC Current	$\text{TestLimits} = \text{TestValue} \pm (\text{TestValue} * \text{ppm of reading} + \text{DMM Range} * \text{ppm of range})$
AC Voltage	$\text{TestLimits} = \text{TestValue} \pm (\text{TestValue} * \% \text{ of reading} + \text{DMM Range} * \% \text{ of range})$
AC Current	$\text{TestLimits} = \text{TestValue} \pm (\text{TestValue} * \% \text{ of reading} + \text{DMM Range} * \% \text{ of range})$
Resistance (4-Wire and 2-Wire)	$\text{TestLimits} = \text{TestValue} \pm (\text{TestValue} * \text{ppm of reading} + \text{DMM Range} * \text{ppm of range})$

### Related concepts:

- [Launching a Calibration Procedure](#)

## NI 4070/4072 Calibration Procedure

Calibrate the PXI/PCI-4070 and PXI-4072 using Calibration Executive.

### Calibration Executive Procedure Features

Verify Only ✓	Verify & Adjust ✓	Manual Mode ✓	Optional Adjust ✗
---------------	-------------------	---------------	-------------------

### Approximate Test Time

180 minutes



**Note** For a list of the TestLimits used in this calibration procedure, refer to the **NI 4070/4072 6-½ Digit FlexDMM Calibration Procedure**, available at [ni.com/docs](http://ni.com/docs) or [ni.com/calibration](http://ni.com/calibration).

### Test Equipment

The following table lists the test equipment required to calibrate all NI 4070/4072 devices.

**Table 156.** Test equipment for calibrating the PXI/PCI-4070 and PXI-4072

Instrument	Recommended Model	Requirements
Calibrator	Fluke 5700A/5720A/5730A*	You must use a Fluke 5700A/5720A/5730A to calibrate NI 4070/4072 modules. Do not use a Fluke 5500A/5520A/5522A calibrator.  The Fluke 5700A multifunction calibrator must be within the 90 day calibration interval. The Fluke 5720A/5730A multifunction calibrator must be within the one year calibration interval.
Function Generator	Agilent 33250A	Use a function generator with a timebase accuracy of 25 ppm or better and a frequency range of 1 Hz to 500 kHz.
Cables	Fluke 5440 low thermal	Use two sets of low thermal electromotive force (EMF) copper cables.

Instrument	Recommended Model	Requirements
	electromotiveforce (EMF) copper cables	
	Pomona B-4 banana-to-banana patch cables	Use two banana-to-banana patch cables with length not to exceed 4 in.
	Pomona 2249-C BNC Cable	Use a 36 inch BNC cable to connect to the function generator.
Connection Accessory	Pomona 1269	Use a BNC female to banana connector to connect the BNC cable to the NI 4070/4072.
Shorting Bar	Pomona 5145 insulated double banana plug shorting bar	Use to create a short with low thermal EMF ( $\leq 150$ nV) across the HI and LO input banana plug connectors on the NI 4070/4072.
Chassis	PXI-1042, PXI-1042Q	Use with PXI modules.



**Note** \* The Calibration Executive driver defaults to the Fluke 5725A Amplifier for values  $>1.9$  A.

The following table lists the additional equipment required to calibrate NI 4072 devices.

**Table 157.** Additional Requirements for NI 4072 Devices

Instrument	Specifications
Resistors	25 $\Omega$ , 125 $\Omega$ , 5 k $\Omega$ , and 100 k $\Omega$ resistors with thermal drift $\leq 5$ ppm/ $^{\circ}\text{C}$ and tolerance $\leq 1\%$ . The distance between the resistor leads and the NI 4072 terminals should be $\leq 1$ in.  NI recommends using the IET SRX-NI-4082 resistance standard kit.
Verification capacitors	Verification capacitors calibrated to at least four times the accuracy of the NI 4072, with temperature coefficients $\leq 250$ ppm/ $^{\circ}\text{C}$ . The values of the verification capacitors

Instrument	Specifications
	should cover the complete capacitance range. NI recommends using traceable capacitor standards with values $\geq 10\%$ of full range for all ranges, except the 300 pF range, which requires a capacitor with values between 90 – 100% of full scale should be used. NI recommends using the capacitance standards of the SCA Series from IET Labs. This calibration procedure assumes the use of 270 pF, 1 nF, 100 nF, 10 $\mu$ F, and 1,000 $\mu$ F standards.
Coaxial cables	If you are using cables to connect the verification capacitors to the NI 4072 banana plug connectors, NI recommends using Pasternack Pe3005 banana-to-banana coaxial cables with length $\leq 4$ inches and total capacitance $\leq 40$ pF. Before performing the verification procedure, you should know the total capacitance up to the end of the banana connectors that plug into the NI 4072

## Test Conditions

The following setup and environmental conditions are required to ensure the NI 4070/4072 meets published specifications.

- (PXI) Ensure that the PXI chassis fan speed is set to HIGH, that the fan filters are clean, and that the empty slots contain filler panels.
- Plug the PXI chassis or PC and the calibrator into the same power strip to avoid ground loops.
- Power on and warm up both the calibrator and the NI 4070/4072 for at least 60 minutes before beginning this calibration procedure.
- Maintain an ambient temperature of  $23 \pm 1$  °C.
- Maintain an ambient relative humidity of less than 60%.
- Keep a shorting bar connected between the V GUARD and GROUND binding posts of the calibrator at all times.
- Clean any oxidation from the banana plugs on the Fluke 5440 cables before plugging them into the binding posts of the calibrator or the banana plug connectors of the NI 4070/4072. Oxidation tarnishes the copper banana plugs so that they appear dull rather than shiny and leads to greater thermal EMF.
- Keep the blue banana plugs on the Fluke 5440 cables connected to the v GUARD binding post of the calibrator at all times.
- Prevent the cables from moving or vibrating by taping or strapping them to a nonvibrating surface. Movement or vibration causes triboelectric effects that can result in measurement errors.

## Device Setup



**Hazardous Voltage** For a list of the TestLimits used in this calibration procedure, refer to the NI 4070/4072 6-½ Digit FlexDMM Calibration Procedure, available at [ni.com/docs](http://ni.com/docs) or [ni.com/calibration](http://ni.com/calibration).

To set up the NI 4070/4072 for calibration, complete the following steps:

1. Install the NI 4070/4072 in the PXI chassis or the PC according to the instructions in the NI Digital Multimeters Getting Started Guide.
2. Configure the hardware using Measurement & Automation Explorer (MAX).
3. Launch the Calibration Executive procedure and complete the setup wizard.

Calibration Executive guides you through the connections required for calibration.



**Note** If you abort the NI 4070/4072 procedure during Self Calibration or Adjustment, you must run cleanup. Do not kill the process. This is necessary to avoid damaging the NI 4070/4072.



**Note** If the NI 4070/4072 fails after calibration, refer to the . If the device still fails after you complete the troubleshooting procedures, return it to NI for repair or replacement.

## Troubleshooting Guidelines

### Error Code –1074118135

(Error Message: Invalid leakage resistance, contact NI for assistance) This error can occur during adjustment when the NI DMM circuitry is too hot. Make sure you follow the instructions in the section to maintain a proper test environment

### Error Code –300300

Version 2.7.0 of NI-DMM is not compatible with Calibration Executive. You must install a different version of this driver in order to run Calibration Executive.



## Other Issues

If the NI 4070/4072 is not recognized in MAX, make sure that you followed the configuration guidelines. If MAX fails to recognize the NI 4070 after you reconfigure, contact National Instruments technical support.

If the NI 4070/4072 fails after calibration, try the following:

1. Check the connections and run the Calibration Executive procedure again.
2. If the calibration still fails after trying step 1, try verifying the failed Test Points using the DMM Soft Front Panel (SFP), which is located at **Start » All Programs » National Instruments » NI-DMM » NI-DMM Soft Front Panel**. For example, if the analog input (AI) failed at 10.00 VDC, input that value from the calibrator.
  - a. Launch the DMM SFP.
  - b. Using the controls on the DMM SFP, select the appropriate mode and range as follows:
    - **mode:** V DC
    - **range:** 10.00 V
3. Check the reading on the display.

If the reading falls outside the range of limits shown in the calibration report after you complete steps 1 and 2, contact NI for repair or replacement. If the reading falls within the limits, you can change the calibration report to indicate the passing value.



**Note** If you have Microsoft Access 2000 or later installed on the computer, you can also modify the database containing the test results. By default, this database is located in `Program Files\National Instruments\Calibration Executive\Databases\Calibration Reports.mdb`.

## Test Limit Equations

The following test limits are derived from the published specifications.



**Note** All DC accuracy specifications apply to 6½-digit resolution (1 PLC), Auto Zero and ADC calibration enabled. All AC accuracy specifications apply to 6½ digit resolution, signal amplitudes greater than 1% of range, and Auto

Zero enabled.

**Table 158.** Test Limit Equations for the NI 4070

Equation Type	Equation
DC Voltage	$\text{TestLimits} = \text{TestValue} \pm (\text{TestValue} * \text{ppm of reading} + \text{DMMRange} * \text{ppm of range})$
DC Current	$\text{TestLimits} = \text{TestValue} \pm (\text{TestValue} * \text{ppm of reading} + \text{DMMRange} * \text{ppm of range})$
AC Voltage	$\text{TestLimits} = \text{TestValue} \pm (\text{TestValue} * \% \text{ of reading} + \text{DMMRange} * \% \text{ of range})$
AC Current	$\text{TestLimits} = \text{TestValue} \pm (\text{TestValue} * \% \text{ of reading} + \text{DMMRange} * \% \text{ of range})$
Resistance (4-Wire and 2-Wire)	$\text{TestLimits} = \text{TestValue} \pm (\text{TestValue} * \text{ppm of reading} + \text{DMMRange} * \text{ppm of range})$
Frequency	$\text{TestLimits} = \text{TestValue} \pm (\text{TestValue} * \% \text{ of reading})$

**Table 159.** Test Limit Equations for the NI 4072

Equation Type	Equation
DC Voltage	$\text{TestLimits} = \text{TestValue} \pm (\text{TestValue} * \text{ppm of reading} + \text{DMMRange} * \text{ppm of range})$
DC Current	$\text{TestLimits} = \text{TestValue} \pm (\text{TestValue} * \text{ppm of reading} + \text{DMMRange} * \text{ppm of range})$
AC Voltage	$\text{TestLimits} = \text{TestValue} \pm (\text{TestValue} * \% \text{ of reading} + \text{DMMRange} * \% \text{ of range})$
AC Current	$\text{TestLimits} = \text{TestValue} \pm (\text{TestValue} * \% \text{ of reading} + \text{DMMRange} * \% \text{ of range})$
Resistance (4-Wire and 2-Wire)	$\text{TestLimits} = \text{TestValue} \pm (\text{TestValue} * \text{ppm of reading} + \text{DMMRange} * \text{ppm of range})$
Frequency	$\text{TestLimits} = \text{TestValue} \pm (\text{TestValue} * \% \text{ of reading})$
Capacitance and	$\text{TestLimits} = \text{TestValue} \pm (\text{TestValue} * \% \text{ of reading} + \text{DMMRange} * \% \text{ of range})$

Equation Type	Equation
Inductance	range)

### Related concepts:

- [Launching a Calibration Procedure](#)

## PXI-4071 Calibration Procedure

Calibrate the PXI-4071 using Calibration Executive.

### Calibration Executive Procedure Features

Verify Only ✓	Verify & Adjust ✓	Manual Mode ✓	Optional Adjust ✗
---------------	-------------------	---------------	-------------------

### Approximate Test Time

180 minutes



**Note** For a list of the TestLimits used in this calibration procedure, refer to the *NI 4071 7½-Digit FlexDMM Calibration Procedure*, available at [ni.com/docs](http://ni.com/docs) or [ni.com/calibration](http://ni.com/calibration).

### Test Equipment

The following table lists the test equipment required to calibrate the PXI-4071.

**Table 312.** Test equipment for calibrating the PXI-4071

Instrument	Recommended Model	Requirements
Calibrator	Fluke 5720A/5730A*	<p>You must use a Fluke 5720A/5730A to calibrate PXI-4071 modules. Do not use a Fluke 5500A/5520A/5522A calibrator.</p> <p>The Fluke 5720A/5730A multifunction calibrator must be within the 90 day calibration interval. †</p>

Instrument	Recommended Model	Requirements
DMM ‡	Agilent 3458A	$\pm(\text{ppm of reading} + \text{ppm of range})$ $\pm 100 \mu\text{A} = \pm(25 + 8)$ $\pm 1 \text{ mA} = \pm(25 + 5)$
Function Generator	Agilent 33250A	Use a function generator with a timebase accuracy of 25 ppm or better and a frequency range of 1 Hz to 500 kHz.
Cables	Fluke 5440 low thermal electromotive force (EMF) copper cables	Use two sets of low thermal electromotive force (EMF) copper cables.
	Pomona B-4 banana-to-banana patch cables	Use two banana-to-banana patch cables with length not to exceed 4 in.
	Pomona 2249-C BNC Cable	Use a 36 inch BNC cable to connect to the function generator.
Connection Accessory	Pomona 1269	Use a BNC female to banana connector to connect the BNC cable to the PXI-4071.
Shorting Bar	Pomona 5145 insulated double banana plug shorting bar	Use to create a short ( $\leq 100 \text{ m}\Omega$ ) with low thermal EMF ( $\leq 150 \text{ nV}$ ) across the HI and LO input banana plug connectors on the PXI-4071.
Binding Post	Pomona 5405	Double banana plug with binding posts.
Spade Lug	Pomona 2305	Use two Pomona 2305 insulated low thermal electromotive force (EMF) spade lugs.
Chassis	PXI-1042, PXI-1042Q	Use with PXI modules.



## Note

- \*The Calibration Executive driver defaults to the Fluke 5725A Amplifier for values  $>1.9 \text{ A}$ .
- †The 90-day DC current uncertainty of the Fluke 5720A/5730A is not adequate to calibrate the four lowest DC current ranges on the PXI-4071. Refer to the to the **NI 4071 7½-Digit FlexDMM**

**Calibration Procedure** for more information on the required uncertainty.

- ‡The Agilent 3458A DMM is used to characterize the DC current output at  $\pm 100 \mu\text{A}$  and  $\pm 1\text{mA}$ . See **DCI Characterization for the NI 4071 Calibration Procedure**.



**Note** You must characterize the Fluke 5720A/5730A calibrator output to better than published specifications. Refer to the **NI 4071 7½-Digit FlexDMM Calibration Procedure** for a characterization example.

## Test Conditions

The following setup and environmental conditions are required to ensure the PXI-4071 meets published specifications.

- Ensure that the PXI chassis fan speed is set to HIGH, that the fan filters are clean, and that the empty slots contain filler panels.
- Plug the PXI chassis or PC and the calibrator into the same power strip to avoid ground loops.
- Power on and warm up both the calibrator and the PXI-4071 for at least 60 minutes before beginning this calibration procedure.
- Maintain an ambient temperature of  $23 \pm 1 \text{ }^\circ\text{C}$ .
- Maintain an ambient relative humidity of less than 60%.
- Keep a shorting bar connected between the v GUARD and GROUND binding posts of the calibrator at all times.
- Clean any oxidation from the banana plugs on the Fluke 5440 cables before plugging them into the binding posts of the calibrator or the banana plug connectors of the PXI-4071. Oxidation tarnishes the copper banana plugs so that they appear dull rather than shiny and leads to greater thermal EMF.
- Keep the blue banana plugs on the Fluke 5440 cables connected to the v GUARD binding post of the calibrator at all times.
- Prevent the cables from moving or vibrating by taping or strapping them to a nonvibrating surface. Movement or vibration causes triboelectric effects that can result in measurement errors.

## Device Setup



**Hazardous Voltage** Voltages as high as 1,000 V can occur during this procedure. Do not touch the calibrator connections during voltage output.

To set up the PXI-4071 for calibration, complete the following steps:

1. Install the PXI-4071 in the PXI chassis or the PC according to the instructions in the ***NI Digital Multimeters Getting Started Guide***.
2. Configure the hardware using Measurement & Automation Explorer (MAX).
3. Launch the Calibration Executive procedure and complete the setup wizard.



**Notice** If you abort the PXI-4071 procedure during Self Calibration or Adjustment, you must run cleanup. Do not kill the process. This is necessary to avoid damaging the PXI-4071.



**Note** If the PXI-4071 fails after calibration, refer to ***Troubleshooting Guidelines***. If the device still fails after you complete the troubleshooting procedures, return it to NI for repair or replacement.

## Troubleshooting Guidelines

### Error Code –1074118135

(Error Message: Invalid leakage resistance, contact NI for assistance) This error can occur during adjustment when the NI DMM circuitry is too hot. Make sure you follow the instructions in the section to maintain a proper test environment

### Error Code –300300

Version 2.7.0 of NI-DMM is not compatible with Calibration Executive. You must install a different version of this driver in order to run Calibration Executive.

## Other Issues

If the PXI-4071 is not recognized in MAX, make sure that you followed the configuration

guidelines. If MAX fails to recognize the PXI-4071 after you reconfigure, contact NI technical support.

If the PXI-4071 fails after calibration, try the following:

1. Check the connections and run the Calibration Executive procedure again.
2. If the calibration still fails after trying step 1, try verifying the failed Test Points using the DMM Soft Front Panel (SFP), which is located at **Start»All Programs»National Instruments»NI-DMM»NI-DMM Soft Front Panel**. For example, if the analog input (AI) failed at 10.00 VDC, input that value from the calibrator.
  - a. Launch the DMM SFP.
  - b. Using the controls on the DMM SFP, select the appropriate mode and range as follows:
    - **mode:** V DC
    - **range:** 10.00 V
  - c. Check the reading on the display.

If the reading falls outside the range of limits shown in the calibration report after you complete steps 1 and 2, contact NI for repair or replacement. If the reading falls within the limits, you can change the calibration report to indicate the passing value.



**Note** If you have Microsoft Access 2000 or later installed on the computer, you can also modify the database containing the test results. By default, this database is located in `Program Files\National Instruments\Calibration Executive\Databases\Calibration Reports.mdb`.

## Test Limit Equations

The following test limits are derived from the published specifications.



**Note** All DC voltage accuracy specifications apply to 7½-digit resolution, Auto Zero and ADC calibration enabled. All DC current specifications apply to 6½-digit resolution, Auto Zero and ADC calibration enabled. All resistance specifications apply to 7½-digit resolution, Auto Zero and ADC calibration

enabled. All AC accuracy specifications apply to 6½-digit resolution, signal amplitudes greater than 1% of range, and Auto Zero enabled.

**Table 161.** PXIe-4071 Test Limit Equations

Equation Type	Equation
DC Voltage	$\text{TestLimits} = \text{TestValue} \pm (\text{TestValue} * \text{ppm of reading} + \text{DMM Range} * \text{ppm of range})$
DC Current	$\text{TestLimits} = \text{TestValue} \pm (\text{TestValue} * \text{ppm of reading} + \text{DMM Range} * \text{ppm of range})$
AC Voltage	$\text{TestLimits} = \text{TestValue} \pm (\text{TestValue} * \% \text{ of reading} + \text{DMM Range} * \% \text{ of range})$
AC Current	$\text{TestLimits} = \text{TestValue} \pm (\text{TestValue} * \% \text{ of reading} + \text{DMM Range} * \% \text{ of range})$
Resistance (4-Wire and 2-Wire)	$\text{TestLimits} = \text{TestValue} \pm (\text{TestValue} * \text{ppm of reading} + \text{DMM Range} * \text{ppm of range})$

### Related concepts:

- [DCI Characterization for the NI 4071 Calibration Procedure](#)
- [Launching a Calibration Procedure](#)

### DCI Characterization for the NI 4071 Calibration Procedure

Characterize DC current output for the PXI-4071 at  $\pm 100\mu\text{A}$  and  $\pm 1\text{mA}$ .

This process uses the Agilent 3458A in series with the PXI-4071 device to determine the value of the calibrator current output at  $\pm 100\mu\text{A}$  and  $\pm 1\text{mA}$  during the DC current verification test in Calibration Executive.

### Test Equipment

The following table lists the test equipment required for this procedure.



**Table 162.** Test equipment for characterizing DC current output for the PXI-4071

Equipment	Recommended Model	Specification
Calibrator	Fluke 5720A/5730A	Used as current source only.
DMM	Agilent 3458A	See specification in the NI 4071 Calibration Procedure.
Low Thermal Test Leads (x3)	Fluke 5440A-7002	—

## Preliminary Requirements

The following setup and environmental conditions are required.

- Disconnect the GPIB cable from the Agilent 3458A and configure it as an "Unsupported Instrument" on the Calibration Executive **Required Standards** screen.
- Power on and warm up both the Fluke 5720A/5730A and the Agilent 3458A, and allow for the appropriate warm-up time (Fluke 5720A/5730A: 30 minutes, Agilent 3458A: 4 hours).
- Check to see if Hotkeys have been programmed. Press [F0] and [ENTER] and read the display.
  - If the Display reads Temp?, then no further action is required. Skip to the.
  - If keys have not been programmed, then follow instructions to.

## Programming Hotkeys on the Agilent 3458A

Use the following steps to program shortcuts for Current Temp, TCAL, ACAL, and ranges.

### Program a shortcut for Current Temp

1. Press [0] on the keypad. The display reads DEFKEY F0.
2. Press the [Blue] button in the Function/Range area.
3. Press the [Recall State] button to display the menu.
4. Use the [Up/Down] arrow buttons to scroll the menu to TEMP?.
5. Press [Enter].

The F0 key now shows the Current Temp on the Agilent 3458A in Celsius.

### Program a shortcut for Last Adjustment Temp (TCAL)

1. Press [1] on the keypad. The display reads DEFKEY F1.
2. Press the [Blue] button in the Function/Range area.
3. Press the [Auto CAL] button to display the menu.
4. Use the [Up/Down] arrow buttons to scroll the menu to CAL.
5. Press the [Down] arrow to place the ?.
6. Press the [Right] arrow key to move the display over.
7. On the keypad, press [5] [9].
8. Press [Enter].

The F1 key now shows the Last Adjustment Temp on the Agilent 3458A in Celsius.

### Program a shortcut for Last Auto Cal Temp (ACAL)

1. Press [2] on the keypad. The display reads DEFKEY F2.
2. Press the [Blue] button in the Function/Range area.
3. Press the [Auto CAL] button to display the menu.
4. Use the [Up/Down] arrow buttons to scroll the menu to CAL.
5. Press the [Down] arrow to place ?.
6. Press the [Right] arrow key to move the display over.
7. On the keypad, press [1] [7] [5].
8. Press [Enter].
9. The F2 key now shows the Last Auto CAL Temp on the Agilent 3458A in Celsius.

### Program shortcuts for appropriate ranges

1. Press [3] on the keypad. The display reads DEFKEY F3.
2. Press the [Blue] button in the Function/Range area.
3. Press the [Auto Cal] button to display the menu.
4. Use the [Down] arrow to scroll to DCI.
5. Use the [Right] arrow to move cursor.
6. On the keypad, press [1] [0] [0] [E] [-] [6] [Enter] for the 100  $\mu$ A range.
7. Press [4] on the keypad. The display reads DEFKEY F4.
8. Press the [Blue] button in the Function/Range area.
9. Press the [Auto Cal] button to display the menu.

10. Use the [Down] arrow to scroll to DCI.
11. Use the [Right] arrow to move the cursor.
12. On the keypad, press [1] [E] [-] [3] [Enter] for the 1mA range.

## Verification Procedure

1. Begin the 4071 Procedure in Calibration Executive.
2. At the beginning of the 2-Wire Resistance test, during the thermal wait period, perform the following:
  - a. Press F0 and <Enter> to verify the Current Temp.
  - b. Press F1 and <Enter> to verify that the Adjustment Temp (TCAL) is <math><5^\circ</math> from the Current Temp.
  - c. Press F2 and <Enter> to verify that the Auto Cal Temp (ACAL) is <math><1^\circ</math> from the Current Temp.



**Note** If Auto Cal has not been performed in the last 24 hours, or if the ACAL is >1° from the Current Temp, press [Auto Cal], and ensure that all cables are removed from the Agilent 3458A DMM.

3. Set the NPLC on the Agilent 3458A to 100:
  - a. Press the [NPLC] button.
  - b. On the keypad, press [1] [0] [0].
  - c. Press [Enter].
4. Proceed/Finish with 2-Wire Ohms testing.
5. When Calibration Executive prompts you to enter the characterized value for the 100 $\mu$ A, place the Fluke 5720A/5730A into standby mode:
  - a. Press the [Local] button.
  - b. Once the calibrator is in local mode, press the [OPR/STBY] button to place it in standby mode.
6. Press F3, then [ENTER] on the 3458A to set range to 100  $\mu$ A DCI.
7. Connect the PXI-4071 with the DMM and calibrator as shown in the following

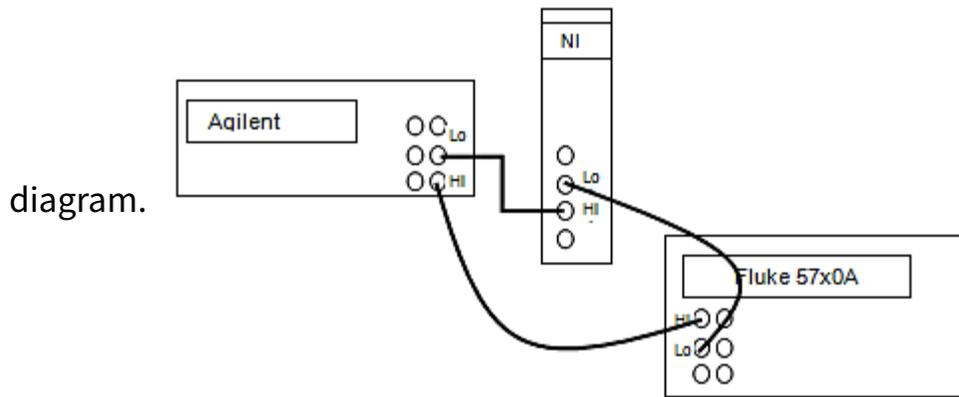

8. Enable the calibrator output by pressing [OPR/STBY] button.
9. Enter the DMM indication for 100  $\mu$ A DCI in the **Characterized Output Value** field at the Calibration Executive prompt.
10. Click **Continue** at the Calibration Executive prompt.
11. Enter the DMM indication for -100  $\mu$ A DCI in the **Characterized Output Value** field at the Calibration Executive prompt. (DO NOT CLICK CONTINUE.)
12. Press F4, then [ENTER] on the 3458A to change to the 1 mA range.

This ensures the DMM does not OVERRANGE when Calibration Executive changes the calibrator output after taking the measurement.

13. Click **Continue** at the Calibration Executive prompt.
14. Enter the DMM indication for 1 mA DCI in the **Characterized Output Value** field at the Calibration Executive prompt.
15. Click **Continue** at the Calibration Executive prompt.
16. Enter the DMM indication for -1 mA DCI in the **Characterized Output Value** field at the Calibration Executive prompt.
17. Click **Continue** at the Calibration Executive prompt.
18. After the -1 mA value has been entered, remove connections from the DMM.
19. Connect the PXI-4071 to the calibrator as shown in prompt, and continue the Calibration Executive procedure.

## DC Current Characterization for Adjustment

To perform a DC current characterization for an adjustment, repeat steps 5—20 of the .

## DC Current Characterization for Re-verification

To perform a DC current characterization for re-verification, repeat steps 5—20 of the .

### Related Documents

Metrology Quality Manual

Agilent 3458A Operators Manual

Fluke 5700A Operators Manual

### Related concepts:

- [PXI-4071 Calibration Procedure](#)

## PXIe-4080/4082 Calibration Procedure

Calibrate the PXIe-4080 and PXIe-4082 using Calibration Executive.

### Calibration Executive Procedure Features

Verify Only ✓	Adjust Only ✓	Verify & Adjust ✓	Manual Mode ✓	Optional Adjust ✗
---------------	---------------	-------------------	---------------	-------------------

### Approximate Test Time

Warm Up	Verify Only	Adjust Only	Verify & Adjust
60 minutes	30 minutes	35 minutes	90 minutes



**Note** For a list of the Test Limits used in this calibration procedure, refer to the ***PXIe-4080/4082 6½-Digit DMM Calibration Procedure***, available at [ni.com/docs](http://ni.com/docs).

### Test Equipment

The following table lists the test equipment required to calibrate all PXIe-4080/4082

devices.

**Table 312.** Test equipment for calibrating the PXIe-4080/4082

Instrument	Recommended Model	Requirements
Multifunction Calibrator	Fluke 5720A or 5730A	Maintained at 90-day specifications
Low Thermal Cables (x2 sets)	Fluke 5440 low thermal electromotive force (EMF) copper cables	Shielded twisted pair copper cables with copper or gold-plated copper banana plugs
Banana Shorting Bar	Pomona 5145	$\leq 40 \text{ m}\Omega$ resistance
Double Banana Plug with Binding Posts	Pomona 5405	Gold-plated copper
Insulated Low Thermal EMF Spade Lugs (x2)	Pomona 2305	Gold-plated copper

The following table lists additional equipment required to run capacitance and inductance tests for the PXIe-4082.

**Table 312.** (PXIe-4082) Additional Requirements for Capacitance and Inductance Tests

Equipment	Recommended Model	Requirements
25 $\Omega$ , 125 $\Omega$ , 5 k $\Omega$ , and 100 k $\Omega$ resistors	NI recommends using the IET SRX-NI-4082 resistance standard kit.	$\leq 1\%$ tolerance $\leq 5 \text{ ppm}/^\circ\text{C}$ temperature coefficient $\leq 1$ inch from resistor to DMM terminals
270 pF, 1 nF, 100 nF, 10 $\mu\text{F}$ , and 1,000 $\mu\text{F}$ capacitors	IET SCA series	$\leq 0.1\%$ uncertainty
Banana-to-Banana Coax Cable	Pasternack PE3005	$\leq 40 \text{ pF}$

## Test Conditions

The following setup and environmental conditions are required to ensure the PXIe-4080/4082 meets published specifications.

- Ensure that the PXI chassis fan speed is set to HIGH, that the fan filters are clean, and that the empty slots contain filler panels.
- Plug the PXI chassis and the calibrator into the same power strip to avoid ground loops.
- Power on and warm up both the calibrator and the PXIe-4080/4082 for at least 60 minutes before beginning this calibration procedure.
- Maintain an ambient temperature of  $23 \pm 1$  °C.
- Maintain an ambient relative humidity of less than 80%.
- Allow the calibrator to settle fully before taking any measurements. Consult the calibrator user documentation for instructions.
- Allow the thermal EMF enough time to stabilize when you change connections to the calibrator or the PXIe-4080/4082.
- Keep a shorting bar connected between the V-GUARD and GROUND binding posts of the calibrator at all times.
- Clean any oxidation from the banana plugs on the cables before plugging them into the binding posts of the calibrator or the connectors of the PXIe-4080/4082. Oxidation tarnishes the copper banana plugs so that they appear dull rather than shiny and leads to greater thermal EMF.
- Prevent the cables from moving or vibrating by taping or strapping them to a nonvibrating surface. Movement or vibration causes triboelectric effects that can result in measurement errors.

## Device Setup

To set up the PXIe-4080/4082 for calibration, complete the following steps:

1. Install the PXIe-4080/4082 in the PXI chassis according to the instructions in the NI PXIe-4080/4081/4082 Getting Started Guide.
2. Configure the hardware using Measurement & Automation Explorer (MAX).
3. Launch the Calibration Executive procedure and complete the setup wizard.

Calibration Executive guides you through the connections required for calibration.



**Note** If the PXIe-4080/4082 fails after calibration, return it to NI for repair or replacement.

## Test Limit Equations

The following test limits are derived from the published specifications.



**Note** All DC accuracy specifications apply to 6½-digit resolution (1 PLC), Auto Zero and ADC calibration enabled. All AC accuracy specifications apply to 6½ digit resolution, signal amplitudes greater than 1% of range, and Auto Zero enabled.

**Table 165.** PXIe-4080/4082 Test Limit Equations

Equation Type	Equation
DC Voltage, DC Current and Resistance (4-Wire and 2-Wire)	$\text{TestLimits} = \text{TestValue} \pm (\text{TestValue} * \text{ppm of reading} + \text{DMMRange} * \text{ppm of range})$
AC Voltage, AC Current	$\text{TestLimits} = \text{TestValue} \pm (\text{TestValue} * \% \text{ of reading} + \text{DMMRange} * \% \text{ of range})$
Capacitance and Inductance (PXIe-4082 only)	$\text{TestLimits} = \text{TestValue} \pm (\text{TestValue} * \% \text{ of reading} + \text{DMMRange} * \% \text{ of range})$

### Related concepts:

- [Launching a Calibration Procedure](#)

## PXIe-4081 Calibration Procedure

Calibrate the PXIe-4081 using Calibration Executive.

### Calibration Executive Procedure Features

Verify Only ✓	Adjust Only ✓	Verify & Adjust ✓	Manual Mode ✓	Optional Adjust ✗
---------------	---------------	-------------------	---------------	-------------------

### Approximate Test Time

Warm Up	Verify Only	Adjust Only	Verify & Adjust
60 minutes	30 minutes	35 minutes	90 minutes





**Note** For a list of the Test Limits used in this calibration procedure, refer to the **PXIe-4081 7½-Digit FlexDMM Calibration Procedure**, available at [ni.com/docs](http://ni.com/docs).

## Test Equipment

The following table lists the test equipment required to calibrate all PXIe-4081 devices.

**Table 312.** Test equipment for calibrating the PXIe-4081

Instrument	Recommended Model	Requirements
Multifunction Calibrator	Fluke 5720A or 5730A	Maintained at 90-day specifications
Low Thermal Cables (x3 sets)	Fluke 5440 low thermal electromotive force (EMF) copper cables	Shielded twisted pair copper cables with copper or gold-plated copper banana plugs
Banana Shorting Bar	Pomona 5145	≤40 mΩ resistance
Double Banana Plug with Binding Posts	Pomona 5405	Gold-plated copper
Insulated Low Thermal EMF Spade Lugs (x2)	Pomona 2305	Gold-plated copper
Ammeter	Keysight 3458A	≤40 ppm uncertainty (100 μA and 1 mA ranges)

## Test Conditions

The following setup and environmental conditions are required to ensure the PXIe-4081 meets published specifications.

- Ensure that the PXI chassis fan speed is set to HIGH, that the fan filters are clean, and that the empty slots contain filler panels.
- Plug the PXI chassis and the calibrator into the same power strip to avoid ground loops.
- Power on and warm up both the calibrator and the PXIe-4081 for at least 60 minutes before beginning this calibration procedure.

- Allow a warm-up time for all of the instruments and equipment according to the manufacturer instructions.
- Maintain an ambient temperature of  $23 \pm 1$  °C.
- Maintain an ambient relative humidity of less than 80%.
- Allow the calibrator to settle fully before taking any measurements. Consult the calibrator user documentation for instructions.
- Allow the thermal EMF enough time to stabilize when you change connections to the calibrator or the PXIe-4081.
- Keep a shorting bar connected between the V-GUARD and GROUND binding posts of the calibrator at all times.
- Clean any oxidation from the banana plugs on the cables before plugging them into the binding posts of the calibrator or the connectors of the PXIe-4081. Oxidation tarnishes the copper banana plugs so that they appear dull rather than shiny and leads to greater thermal EMF.
- Prevent the cables from moving or vibrating by taping or strapping them to a nonvibrating surface. Movement or vibration causes triboelectric effects that can result in measurement errors.

## Device Setup

To set up the PXIe-4081 for calibration, complete the following steps:

1. Install the PXIe-4081 in the PXI chassis according to the instructions in the NI PXIe-4080/4081/4082 Getting Started Guide.
2. Configure the hardware using Measurement & Automation Explorer (MAX).
3. Launch the Calibration Executive procedure and complete the setup wizard.

Calibration Executive guides you through the connections required for calibration.



**Note** If the PXIe-4081 fails after calibration, return it to NI for repair or replacement.

## Test Limit Equations

The following test limits are derived from the published specifications.



**Note** All DC voltage accuracy specifications apply to 7½-digit resolution, Auto Zero and ADC calibration enabled. All DC current specifications apply to 6½-digit resolution, Auto Zero and ADC calibration enabled. All resistance specifications apply to 7½-digit resolution, Auto Zero and ADC calibration enabled. All AC accuracy specifications apply to 6½-digit resolution, signal amplitudes greater than 1% of range, and Auto Zero enabled.

**Table 167.** PXIe-4081 Test Limit Equations

Equation Type	Equation
DC Voltage, DC Current, and Resistance (4-Wire and 2-Wire)	$\text{TestLimits} = \text{TestValue} \pm (\text{TestValue} * \text{ppm of reading} + \text{DMMRange} * \text{ppm of range})$
AC Voltage, AC Current	$\text{TestLimits} = \text{TestValue} \pm (\text{TestValue} * \% \text{ of reading} + \text{DMMRange} * \% \text{ of range})$

### Related concepts:

- [Launching a Calibration Procedure](#)

## High-Speed Digital I/O

Calibrate your high-speed digital I/O devices with Calibration Executive.

### PXIe-6570/6571 Calibration Procedure

Calibrate the PXIe-6570 and PXIe-6571 using Calibration Executive.

### Calibration Executive Procedure Features

Verify Only ✓	Verify & Adjust ✓	Manual Mode ✓	Optional Adjust ⓧ
---------------	-------------------	---------------	-------------------

### Approximate Test Time

Warmup	Verify Only	Verify & Adjust
30 minutes	40 minutes	115 minutes

## Test Equipment

The following table lists the test equipment required for calibrating the PXIe-6570/6571.

**Table 168.** Test equipment for calibrating the PXIe-6570/6571

Instrument	Recommended Model	Specifications	Requirements
Chassis*	PXIe-1095	All	82 W of power, cooling
SMU (2 channels)	PXIe-4143	DC Accuracy	—
Power supply	PXI-4110	Timing Accuracy	Programmable source, 3.3 V, 60 mA
DMM (x2)	PXI-4071	DC Accuracy	7.5 digits voltage
NI 6570 calibration fixture (DC and Timing <sup>†</sup> )	NI P/N 540163A-020  This calibration fixture has limited support and availability.	DC Accuracy, Timing Accuracy	—
Switch	PXIe-2529	DC Accuracy	—
Oscilloscope**	PXIe-5162 (4 CH)	Timing Accuracy	—
Reference clock	PXIe-6674T	Timing Accuracy	10 MHz reference clock Accuracy: $\pm 25$ ppm
Timing calibration fixture cabling	12-inch SMA Cables (x2): NI P/N 763777-01  SMA(f)-to-BNC(m) Adapters (x2)  Cable Ferrite  SMA-to-SMB Cable	Timing Accuracy	See instructions below for connection details
Timing Calibration Fixture Adapter <sup>‡</sup>	NI P/N 171043A-01  This calibration fixture adapter has limited support and	Timing Accuracy	—

Instrument	Recommended Model	Specifications	Requirements
	availability.		
I2C controller	USB-8452 USB cable with ferrites	Timing Accuracy	—
VHDCI-to-VHDCI 68-pin cable	SHC68-C68-D4, NI P/N 152870-01	DC Accuracy	3 GHz



## Note

- \*The PXIe-6571 requires a chassis that can provide 82 W of power and slot cooling.
- \*\*The Oscilloscope standard cannot be used in manual mode for the PXIe-6570/6571 procedure.
- †The timing calibration fixture is sensitive to electrostatic discharge (ESD).
- ‡The timing calibration fixture adapter is required for the PXIe-6571 to perform the timing calibration procedure.

## Test Conditions

The following setup and environmental conditions are required to ensure the PXIe-6570/6571 meets published specifications.

- Keep connections to the device as short as possible. Long cables and wires act as antennas, picking up extra noise that can affect measurements.
- Verify that all connections, including front panel connections, are secure.
- Use shielded VHDCI cables when connecting to the PXIe-6570/6571 front panel.
- Maintain an ambient temperature of  $23 \pm 5$  °C. The device temperature will be greater than the ambient temperature.
- The ambient temperature variation during adjustment and final verification must be within  $\pm 1$  °C.
- Keep relative humidity below 80%.

- Allow recommended warm-up time for all of the instruments and equipment according to the manufacturer instructions.
- Use a torque wrench appropriate for the type of RF connector that you are using. NI recommends a 0.565 N · m (5 lb · in.) wrench for SMA connectors.
- If using a PXIe-1085 chassis to calibrate the PXIe-6570, ensure that the PXIe-1085 chassis fan speed is set to HIGH, the fan filters are removed, and the empty slots contain PXI chassis slot blockers and filler panels. For more information, refer to the Maintain Forced-Air Cooling Note to Users document available at [ni.com/docs](http://ni.com/docs).
- If using a PXIe-1095 chassis to calibrate the PXIe-6570 or PXIe-6571, ensure the PXIe-1095 cooling profile is set to 58W/82W and the fan mode is set to Auto. Ensure the empty slots contain PXI chassis slot blockers and filler panels. For more information, refer to the Maintain Forced-Air Cooling Note to Users document available at [ni.com/docs](http://ni.com/docs).

## Device Setup

1. For PXIe-6571 modules only, verify the slot to the right of the PXIe-6571 to be tested is populated with the Timing Calibration Fixture Adapter.
2. Install the PXIe-6570/6571 in the chassis according to the instructions in the PXIe-6570 Getting Started Guide or PXIe-6571 Getting Started Guide.
3. Configure the hardware using Measurement & Automation Explorer (MAX).
4. Launch the Calibration Executive procedure and complete the setup wizard.

## Timing Calibration Setup

1. Connect the USB-8452 I2C controller and PXI-4110 DC power supply to the timing calibration fixture as shown in the following diagrams. The cabling to connect the components is described in.
2. Remove screws as indicated for the module being tested:



**Note** Be sure to save the screws and put them back into the PXIe-6570/6571 front panel when you are finished with timing calibration.

**PXIe-6570:** Remove 3 of the 4 screws from the front panel so the timing calibration fixture can be screwed onto the PXIe-6570 module. Leave the screw below the PXI ejector handle in place.

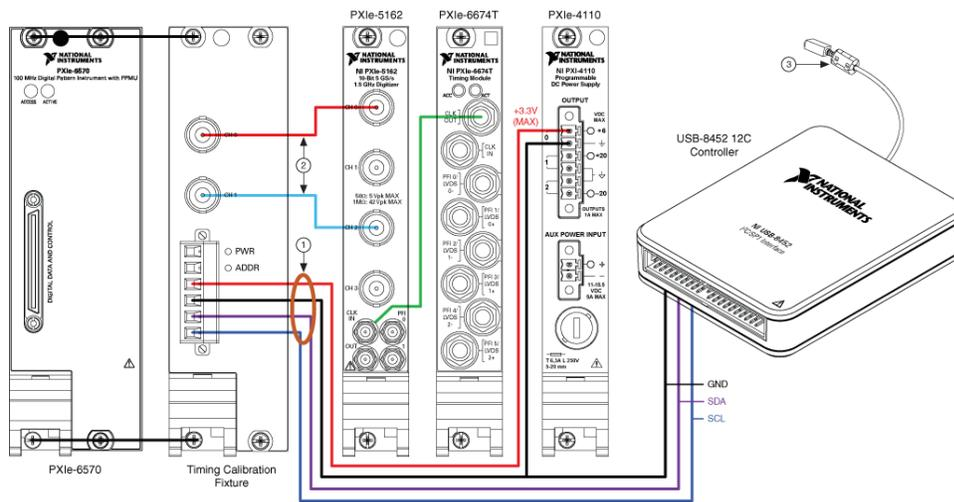

1. Ferrite
2. SMA Cables with SMA-BNC Adapter
3. USB Cable with Ferrite

**PXIe-6571:** Remove the top screw from the front panel so the timing calibration fixture can be screwed onto the PXIe-6571 module. Leave the screw below the PXI ejector handle in place. Verify the timing calibration fixture adapter is populated in the slot to the right of the PXIe-6571 being tested.

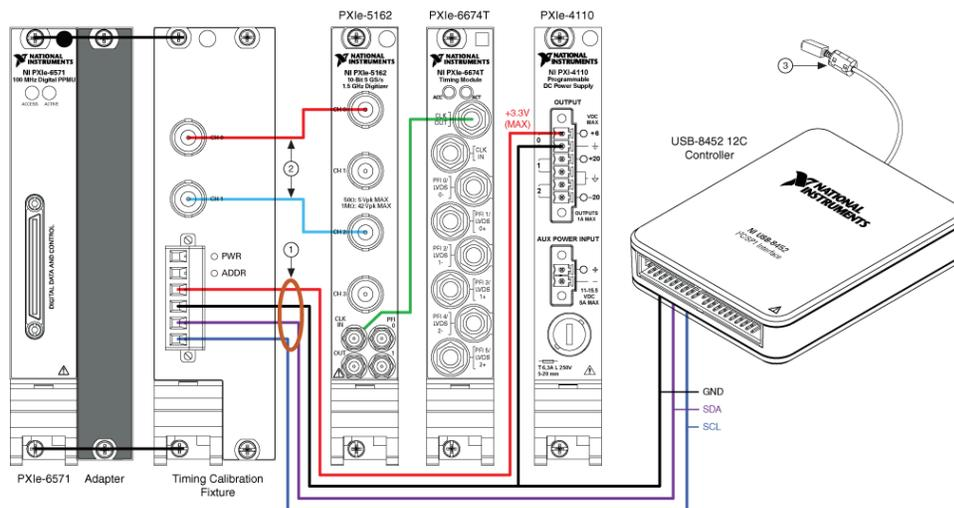

1. Ferrite
2. SMA Cables with SMA-BNC Adapter
3. USB Cable with Ferrite

3. Attach the Timing Calibration Fixture to the front of the PXIe-6570/PXIe-6571 device. Hand tighten the screws on the Timing Calibration Fixture.

## DC Calibration Setup

The DC calibration of the PXIe-6570/6571 uses an NI 2529 switch connected to a

custom fixture that is used to properly route the signals from the PXIe-6570/6571 and to each of the standards used during calibration. Refer to the section for details on properly maintaining the NI 2529 switch. When prompted by Calibration Executive, connect the fixture to the instruments and device as shown in the following diagram. Ensure that you have the banana cables connected to the correct DMM that you selected during setup.

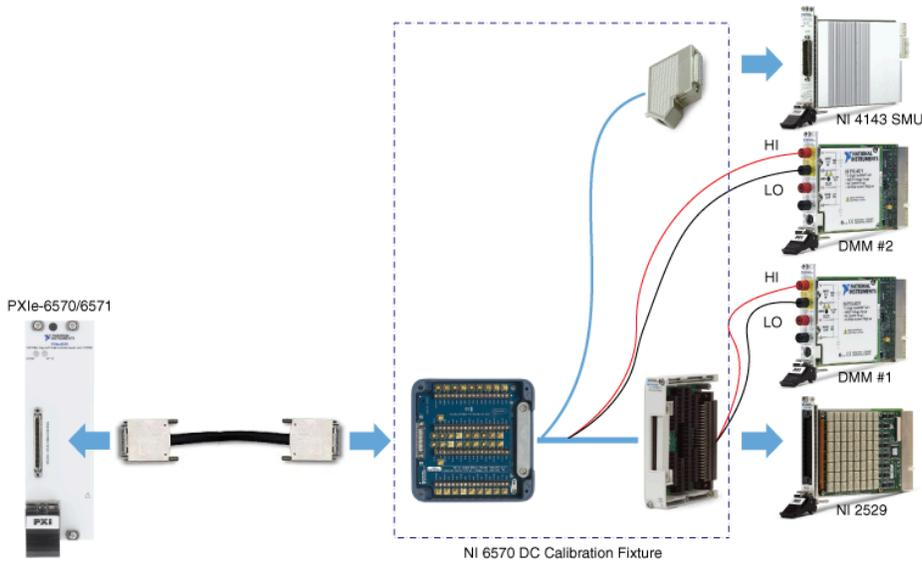

## Switch Maintenance

To ensure proper operation of the switches used in this procedure, you must periodically test the performance of your switch. Refer to the NI 2503/2529 Switch Performance Test for instructions on validating the performance of the NI 2529 used in this procedure.

## Test Limit Equations

The following As Found test limits are derived from the published specifications. The As Left test limits are guard-banded according to manufacturer requirements.

### Timing Accuracy Under Calibration Conditions



**Note** The As Found timing accuracy limits are tighter than the published specifications to account for differences in the calibration conditions and methodology. Using these limits ensures that the PXIe-6570/6571 will meet



the published specifications when used in customer applications.

**Table 169.** PXIe-6570/6571 Test Limit Equations

Equation Type	Equation
Comparator Voltage Level Accuracy Verification Limit	Test Value $\pm$ 25 mV
Driver Voltage Level Accuracy Limit	Test Value $\pm$ 15 mV
PPMU Force Current Accuracy Limit	Test Value $\pm$ (Current Range * 1%)
PPMU Force Voltage Accuracy Limit	Test Value $\pm$ 15 mV
PPMU Measure Current (Zone 1) Accuracy Limit	1 * (SMU Current Reading) $\pm$ (Current Range * 1%)
	-1 * (SMU Current Reading) $\pm$ (Current Range * Test Point Accuracy)
PPMU Measure Current (Zone 2) Accuracy Limit	<div style="border: 1px solid #ccc; padding: 5px; margin-bottom: 5px;">  <b>Note</b> Use 1% test point accuracy for the 1.25 V test points, and 1.5% for all others         </div> <div style="border: 1px solid #ccc; padding: 5px;">  <b>Note</b> For test limits that are set based on the SMU Current Reading or the DMM reading, the actual reading used to set the limits can be determined by calculating the mid-point between the upper and lower limit         </div>
PPMU Measure Voltage Accuracy Limit	(DMM Reading) $\pm$ 5 mV

### Related concepts:

- [Launching a Calibration Procedure](#)
- [NI 2503/2529 Switch Performance Test](#)

### NI 2503/2529 Switch Performance Test

Test the performance of the PXI-2503 and PXI/PXIe-2529 using Calibration Executive.

## Calibration Executive Procedure Features

Verify only ✓	Verify & Adjust ⓧ	Manual Mode ✓	Optional Adjust ⓧ
---------------	-------------------	---------------	-------------------

## Approximate Test Time

Device	Performance Test
PXI-2503	3 minutes
PXI/PXIe-2529	8 minutes

## Test Equipment

The following table lists the test instruments required for testing the NI 2503/2529.

**Table 170.** Equipment for testing PXI-2503 and PXI/PXIe-2529 performance

Instrument	Recommended Model	Requirements
DMM	PXI-4071	Voltage Accuracy: 7.5 digits Resistance Accuracy: 6.5 digits
Terminal Block	PXI-2503: TB-2606 PXI/PXIe-2529: TB-2636	—

The switch performance tests should be executed periodically on switches used with Calibration Executive procedures to check if any switch paths have become damaged, or if the switches are approaching the end of their useful life. The frequency of execution of these tests will depend on many factors, including how often the switches are used.

## Test Conditions

The following setup and environmental conditions are required to ensure the NI 2503/2529 meets published specifications.

- Keep connections to the device as short as possible. Long cables and wires act as antennas, picking up extra noise that can affect measurements.
- Verify that all connections to the device are secure.
- Use shielded copper wire for all cable connections to the device. Use twisted-pair wire to eliminate noise and thermal offsets.
- Maintain an ambient temperature of  $23\text{ }^{\circ}\text{C} \pm 5\text{ }^{\circ}\text{C}$ . The device temperature will be greater than the ambient temperature.
- Keep relative humidity below 80%.

## Device Setup

1. Configure the hardware using Measurement & Automation Explorer (MAX).
2. Launch the Calibration Executive procedure and complete the setup wizard.
3. Complete the following steps to create fixtures that will be used to connect the switches to the DMM.

### Create the NI 2529 Fixture

1. On the TB-2636, connect the positive (+) and negative (-) terminals together for C0—C31.
2. Connect all + terminals together for R0 to R3, and wire them out using two separate wires to banana connectors labeled "DMM HI" and "DMM HI Sense".
3. Connect all - terminals together for R0 to R3, and wire them out using two separate wires to banana connectors labeled "DMM LO" and "DMM LO Sense".

To run the procedure, connect the TB-2636 to the PXI/PXIe-2529 switch, and connect the four banana connectors to the appropriate terminals on the DMM.

### Create the NI 2503 Fixture

1. On the TB-2606, connect the + and - terminals together for C0 to C5.
2. Connect all + terminals together for R0 to R3, and wire them out using two separate wires to banana connectors labeled "DMM HI" and "DMM HI Sense".
3. Connect all - terminals together for R0 to R3, and wire them out using two separate wires to banana connectors labeled "DMM LO" and "DMM LO Sense".

To run the procedure, connect the TB-2606 to the PXI-2503 switch, and connect the four banana connectors to the appropriate terminals on the DMM.

## Test Limit Equations

These switch tests are not intended to be a validation of the full warranted performance of these devices. The parameters and limits used in these tests are based on the needs of the procedures in Calibration Executive that use these switches to ensure they meet the performance requirements of those procedures.

### Related concepts:

- [Launching a Calibration Procedure](#)

## High-Speed Digitizers

Calibrate your high-speed digitizers with Calibration Executive.

### NI 5105 Calibration Procedure

Calibrate the PXI/PXIe/PCI-5105 using Calibration Executive.

### Calibration Executive Procedure Features

Verify Only ✓	Verify & Adjust ✓	Manual Mode ✓	Optional Adjust ✗
---------------	-------------------	---------------	-------------------

### Approximate Test Time

60 minutes

### Test Equipment

The following table lists the test equipment required for calibrating the NI 5105.

**Table 171.** Test equipment for calibrating the NI 5105

Instrument	Recommended Model	Parameter Measured	Minimum Requirements
Scope Calibrator	Fluke 9500B with Fluke 9510 Test Head	DC Accuracy	DC $\pm(0.025\% + 25 \text{ mV})$ into 50 $\Omega$ and 1 M $\Omega$

Instrument	Recommended Model	Parameter Measured	Minimum Requirements
		Bandwidth	$\pm 2\%$ output amplitude flatness for leveled sine wave up to 60 MHz relative to 50 kHz into 50 $\Omega$
		Timing	$\pm 2$ ppm frequency accuracy
Chassis	PXI-1042, PXI-1042Q	—	Use with PXI/PXI Express modules
BNC to SMB Adapter	—	—	50 $\Omega$

## Test Conditions

The following setup and environmental conditions are required to ensure the NI 5105 meets published specifications.

- Always connect the calibrator test head directly to the input SMB of the digitizer using the BNC to SMB adapter. Long cables and wires act as antennas, picking up extra noise that can affect measurements.



**Note** Make sure the calibration test head has mechanical support to prevent unnecessary strain on the SMB connector of the digitizer.

- Keep relative humidity between 10 and 90% non-condensing, or consult the digitizer hardware specifications for the optimum relative humidity.
- Maintain an ambient temperature of  $23 \pm 5$  °C.
- Allow a warm-up time of at least 15 minutes after the NI-SCOPE driver is loaded. Unless manually disabled, the NI-SCOPE driver automatically loads with the operating system and enables the device. The warm-up time ensures that the measurement circuitry of the NI 5105 is at a stable operating temperature.
- Plug the PXI/PXI Express chassis or PC and the calibrator into the same power strip to avoid ground loops.
- (PXI/PXIe) Ensure that the PXI/PXI Express chassis fan speed is set to HIGH, that the fan filters are clean, and that the empty slots contain filler panels.

## Device Setup

1. Install the NI 5105 in the PXI/PXI Express chassis or PC according to the instructions in the NI High-Speed Digitizers Getting Started Guide.
2. Configure the hardware using Measurement & Automation Explorer (MAX).
3. Launch the Calibration Executive procedure and complete the setup wizard.



**Note** If the NI 5105 module fails after calibration, return it to NI for repair or replacement.

## Test Limit Equations

The following test limits are derived from the published specifications.

**Table 172.** NI 5105 PXI/PXIe Test Limit Equations

Equation Type	Equation
Vertical Offset	50 $\Omega$ Input Impedance (All Ranges) <ul style="list-style-type: none"> <li>• TestLimits = TestValue <math>\pm</math> (Range * 0.25% of FS + 1.4 mV)</li> </ul> 1 M $\Omega$ Input Impedance (All Ranges) <ul style="list-style-type: none"> <li>• TestLimits = TestValue <math>\pm</math> (Range * 0.25% of FS + 1.4 mV)</li> </ul>
Vertical Gain	50 $\Omega$ Input Impedance (All Ranges) <ul style="list-style-type: none"> <li>• TestLimits = TestValue <math>\pm</math> (TestValue * 1% of Input)</li> </ul> 1 M $\Omega$ Input Impedance (50 mV Range) <ul style="list-style-type: none"> <li>• TestLimits = TestValue <math>\pm</math> (TestValue * 1% of Input)</li> </ul> 1 M $\Omega$ Input Impedance (200 mV, 1 V, and 6 V Ranges)

Equation Type	Equation
	<ul style="list-style-type: none"> <li>• <math>\text{TestLimits} = \text{TestValue} \pm (\text{TestValue} * 0.65\% \text{ of Input})</math></li> </ul> <p>1 M<math>\Omega</math> Input Impedance (30 V Range)</p> <ul style="list-style-type: none"> <li>• <math>\text{TestLimits} = \text{TestValue} \pm (\text{TestValue} * 0.75\% \text{ of Input})</math></li> </ul>
Timing Accuracy	$\text{TestLimits} = \text{TestValue} \pm 25 \text{ ppm}$ (Not Phase-Locked to Reference Clock)
Bandwidth	$\text{TestLimits} = \text{TestValue} \pm 3 \text{ dB}$

**Table 173.** NI 5105 PCI Test Limit Equations

Equation Type	Equation
Vertical Offset	<p>50 <math>\Omega</math> Input Impedance (All Ranges)</p> <ul style="list-style-type: none"> <li>• <math>\text{TestLimits} = \text{TestValue} \pm (\text{Range} * 0.25\% \text{ of FS} + 600 \mu\text{V})</math></li> </ul> <p>1 M<math>\Omega</math> Input Impedance (All Ranges)</p> <ul style="list-style-type: none"> <li>• <math>\text{TestLimits} = \text{TestValue} \pm (\text{Range} * 0.25\% \text{ of FS} + 1.4 \text{ mV})</math></li> </ul>
Vertical Gain	<p>50 <math>\Omega</math> Input Impedance (All Ranges)</p> <ul style="list-style-type: none"> <li>• <math>\text{TestLimits} = \text{TestValue} \pm (\text{TestValue} * 1\% \text{ of Input})</math></li> </ul> <p>1 M<math>\Omega</math> Input Impedance (50 mV Range)</p> <ul style="list-style-type: none"> <li>• <math>\text{TestLimits} = \text{TestValue} \pm (\text{TestValue} * 1\% \text{ of Input})</math></li> </ul> <p>1 M<math>\Omega</math> Input Impedance (200 mV, 1 V, and 6 V Ranges)</p>

Equation Type	Equation
	<ul style="list-style-type: none"> <li>• <math>\text{TestLimits} = \text{TestValue} \pm (\text{TestValue} * 0.65\% \text{ of Input})</math></li> </ul> <p>1 MΩ Input Impedance (30 V Range)</p> <ul style="list-style-type: none"> <li>• <math>\text{TestLimits} = \text{TestValue} \pm (\text{TestValue} * 0.75\% \text{ of Input})</math></li> </ul>
Timing Accuracy	$\text{TestLimits} = \text{TestValue} \pm 25 \text{ ppm (Not Phase-Locked to Reference Clock)}$
Bandwidth	$\text{TestLimits} = \text{TestValue} \pm 3 \text{ dB}$

**Related concepts:**

- [Launching a Calibration Procedure](#)

## PXIe-5110/5111/5113 Calibration Procedure

Calibrate the PXIe-5110/5111/5113 using Calibration Executive.

### Calibration Executive Procedure Features

Verify Only ✓	Adjust Only ✓	Verify & Adjust ✓	Manual Mode ✓	Optional Adjust ✓
---------------	---------------	-------------------	---------------	-------------------

### Approximate Test Time

Verify Only	Adjust Only	Verify & Adjust
15 minutes	9 minutes	36 minutes

### Test Equipment

The following table lists the test equipment required for calibrating PXIe-5110/5111/5113 modules.



Table 312. Test equipment for calibrating the PXIe-5110/5111/5113

Instrument	Recommended Model	Where Used	Minimum Requirements
Oscilloscope calibrator	Fluke 9500B/600 with Fluke 9530 Active Head	DC accuracy verification  Adjustment	Square wave generation: <ul style="list-style-type: none"> <li>• Amplitude: 0.02 V<sub>pk-pk</sub> to 20 V<sub>pk-pk</sub> into 1 MΩ symmetrical to ground (0 V)</li> <li>• Frequency: 500 Hz</li> <li>• Abberations: &lt;2% of peak for the first 500 ns</li> </ul>
			DC generation: <ul style="list-style-type: none"> <li>• Amplitude: ±5.0 V into 50 Ω, ±118 V into 1 MΩ</li> <li>• Accuracy: ±(0.025% of output + 25 μV)</li> </ul>
Power sensor	Rohde & Schwarz NRP6A or NRP-Z91	Test system characterization  Verification: 50 Ω bandwidth	Power measurement: <ul style="list-style-type: none"> <li>• Frequency range: 50 kHz to 476 MHz</li> <li>• Power range: -27 dBm to 10 dBm</li> <li>• VSWR: &lt;1.11</li> <li>• Absolute accuracy: <ul style="list-style-type: none"> <li>◦ &lt;0.048 dB for 50 kHz</li> <li>◦ &lt;0.063 dB for 100.1 MHz to 476 MHz</li> </ul> </li> <li>• Relative accuracy at -4 dBm: &lt;0.022 dB for 50 kHz to 476 MHz</li> </ul>
Signal generator	Rohde & Schwarz SMA100A base unit with required frequency option SMA-B103	Test system characterization  Verification: 50 Ω bandwidth	Sine wave generation: <ul style="list-style-type: none"> <li>• Amplitude: -22 dBm to 16 dBm</li> <li>• Frequency: 50 kHz to 476 MHz</li> </ul>

Instrument	Recommended Model	Where Used	Minimum Requirements
			<ul style="list-style-type: none"> <li>• Harmonics: &lt;-30 dBc</li> <li>• Frequency accuracy: <math>\pm 100</math> ppm</li> </ul>
Power splitter	Aeroflex/Weinschel 1593	Test system characterization  Verification: 50 $\Omega$ bandwidth	Amplitude: -22 dBm to 16 dBm  Frequency: 50 kHz to 476 MHz  VSWR: <1.25
50 $\Omega$ BNC terminator (f)	Fairview Microwave ST3B-F	Test system characterization	Impedance: 50 $\Omega$  Frequency: DC to 476 MHz  VSWR: <1.1
SMA (m)-to-SMA (m) cable	—	Test system characterization  Verification: 50 $\Omega$ bandwidth	Frequency: DC to 476 MHz  VSWR: <1.1  Length: $\leq 1$ m
SMA (f)-to-N (m) adapter	Fairview Microwave SM4226	Test system characterization  Verification: 50 $\Omega$ bandwidth	Frequency: DC to 476 MHz  VSWR: <1.05
BNC (f)-to-N (f) adapter	Fairview Microwave SM3526	Test system characterization  Verification: 50 $\Omega$ bandwidth	Frequency: DC to 476 MHz  VSWR: <1.1  Impedance: 50 $\Omega$
SMA (m)-to-BNC (m) adapter (x2)	Fairview Microwave SM4716	Test system characterization  Verification:	Frequency: DC to 476 MHz  VSWR: <1.1

Instrument	Recommended Model	Where Used	Minimum Requirements
		50 $\Omega$ bandwidth	Impedance: 50 $\Omega$

## Test Conditions

The following setup and environmental conditions are required to ensure the PXIe-5110/5111/5113 meets published specifications.

- Keep cabling as short as possible. Long cables and wires act as antennas, picking up extra noise that can affect measurements.
- Allow the PXIe-5110/5111/5113 to warm up for 15 minutes at ambient temperature. Warmup begins after the chassis is powered and NI-SCOPE is loaded and recognizes the module.
- Allow all test instruments to warm up for at least the period of time stated in the documentation for each instrument. The warm-up time ensures that the test instruments are at a stable operating temperature.
- Verify that all connections, including front panel connections and screws, are secure.
- Use shielded copper wire for all cable connections to the device. Use twisted-pair wire to eliminate noise and thermal offsets.
- Maintain a temperature of 23°C  $\pm$ 3°C.
- Keep relative humidity between 10% and 90%, noncondensing.
- Ensure that the PXI chassis fan speed is set to HIGH, that the fan filters are clean, and that the empty slots contain filler panels. For more information, refer to the ***Maintain Forced-Air Cooling Note to Users*** documents available at [ni.com/docs](http://ni.com/docs).
- Plug the PXI chassis and any other instrument standards into the same power strip to avoid ground loops.

## Device Setup

1. Install the PXIe-5110/5111/5113 in the PXI chassis according to the instructions in the PXIe-5110/5111/5113 Getting Started Guide.
2. Configure the hardware using Measurement & Automation Explorer (MAX).
3. Launch the Calibration Executive procedure and complete the setup wizard.



**Note** If the PXIe-5110/5111/5113 module fails after calibration, return it to NI for repair or replacement.

## Test Limit Equations

**Table 312.** PXIe-5110/5111/5113 Test Limit Equations

Equation Type	Input Impedance	Input Range	Equation
DC Accuracy	50 $\Omega$	0.1 V to 4 V	$\pm[(2\% \times  \text{Reading-Vertical Offset} ) + (0.4\% \times  \text{Vertical Offset} ) + (1\% \text{ of FS}) + 0.2 \text{ mV}]$
	50 $\Omega$	10 V	$\pm[(2\% \times  \text{Reading-Vertical Offset} ) + (1.1\% \times  \text{Vertical Offset} ) + (1\% \text{ of FS}) + 0.2 \text{ mV}]$
	1 M $\Omega$	0.1 V to 20 V	$\pm[(2\% \times  \text{Reading-Vertical Offset} ) + (0.4\% \times  \text{Vertical Offset} ) + (1\% \text{ of FS}) + 0.2 \text{ mV}]$
	1 M $\Omega$	40 V	$\pm[(2\% \times  \text{Reading-Vertical Offset} ) + (1.1\% \times  \text{Vertical Offset} ) + (1\% \text{ of FS}) + 0.2 \text{ mV}]$

**Table 176.** PXIe-5110/5111/5113 Test Limit Equations

Equation Type	Input Impedance	Equation
DC Accuracy	50 $\Omega$	<p>if Input Range is 0.1 V to 4 V = <math>\pm[(2\% \times  \text{Reading-Vertical Offset} ) + (0.4\% \times  \text{Vertical Offset} ) + (1\% \text{ of FS}) + 0.2 \text{ mV}]</math></p> <p>if Input Range is 10 V = <math>\pm[(2\% \times  \text{Reading-Vertical Offset} ) + (1.1\% \times  \text{Vertical Offset} ) + (1\% \text{ of FS}) + 0.2 \text{ mV}]</math></p>
DC Accuracy	1 M $\Omega$	<p>if Input Range is 0.1 V to 20 V = <math>\pm[(2\% \times  \text{Reading-Vertical Offset} ) + (0.4\% \times  \text{Vertical Offset} ) + (1\% \text{ of FS}) + 0.2 \text{ mV}]</math></p> <p>if Input Range is 40 V = <math>\pm[(2\% \times  \text{Reading-Vertical Offset} ) + (1.1\% \times  \text{Vertical Offset} ) + (1\%</math></p>

Equation Type	Input Impedance	Equation
		of FS) + 0.2 mV]

### Related concepts:

- [Launching a Calibration Procedure](#)

## NI 5114 Calibration Procedure

Calibrate the PXI/PXIe/PCI-5114 using Calibration Executive.

### Calibration Executive Procedure Features

Verify Only ✓	Verify & Adjust ✓	Manual Mode ✓	Optional Adjust ✗
---------------	-------------------	---------------	-------------------

### Approximate Test Time

30 minutes

### Test Equipment

The following table lists the test equipment required for calibrating the NI 5114.

**Table 177.** Test equipment for calibrating the NI 5114

Required Equipment	Recommended Equipment	Parameter Measured	Minimum Requirements
Scope Calibrator	Fluke 9500B with Fluke 9510 Test Head	DC Accuracy	DC $\pm(0.025\% + 25 \mu\text{V})$ into 1 M $\Omega$
		Bandwidth, Trigger Sensitivity	$\pm 2\%$ output amplitude flatness for leveled sine wave up to 131 MHz relative to 50 kHz into 50 $\Omega$
		Timing	$\pm 2$ ppm frequency accuracy
Chassis	PXI-1042,	—	Use with PXI/PXI Express modules

Required Equipment	Recommended Equipment	Parameter Measured	Minimum Requirements
	PXI-1042Q		
BNC Cable	—	—	50 $\Omega$ coaxial cable

## Test Conditions

The following setup and environmental conditions are required to ensure the NI 5114 meets published specifications.

- Always connect the calibrator test head directly to the input BNC on the digitizer, or use a short 50  $\Omega$  BNC coaxial cable if necessary. Long cables and wires act as antennas, picking up extra noise that can affect measurement.
- Keep relative humidity between 10 and 90% non-condensing, or consult the digitizer hardware specifications for the optimum relative humidity.
- Maintain an ambient temperature of 23  $\pm$ 5  $^{\circ}$ C.
- Allow a warm-up time of at least 15 minutes after the NI-SCOPE driver is loaded. Unless manually disabled, the NI-SCOPE driver automatically loads with the operating system and enables the device. The warm-up time ensures that the measurement circuitry of the NI 5114 is at a stable operating temperature.
- Plug the PXI/PXI Express chassis or PC and the calibrator into the same power strip to avoid ground loops.
- (PXI/PXIe) Ensure that the PXI/PXI Express chassis fan speed is set to HIGH, that the fan filters are clean, and that the empty slots contain filler panels.

## Device Setup

1. Install the NI 5114 in the PXI/PXI Express chassis or the PC according to the instructions in the NI High-Speed Digitizers Getting Started Guide.
2. Configure the hardware using Measurement & Automation Explorer (MAX).
3. Launch the Calibration Executive procedure and complete the setup wizard.



**Note** If the NI 5114 module fails after calibration, return it to NI for repair or replacement.

## Test Limit Equations

The following test limits are derived from the published specifications.

**Table 178.** NI PXI-5114 Test Limit Equations

Equation Type	Equations
Vertical Offset and Vertical Gain	$\text{TestLimits} = \text{TestValue} \pm (\text{TestValue} * 1.5\% \text{ of Input} + \text{Range} * 0.3\% \text{ of FS} + 200 \mu\text{V})$ <ul style="list-style-type: none"> <li>• Within <math>\pm 5</math> °C of self-calibration temperature</li> </ul>
Programmable Vertical Offset	$\text{TestLimits} = \text{TestValue} \pm 2\% \text{ of offset setting}$ <ul style="list-style-type: none"> <li>• Within <math>\pm 5</math> °C of self-calibration temperature</li> </ul>
Timing	$\text{TestLimits} = \text{Internal Clock} \pm 25 \text{ ppm}$
Bandwidth and Flatness	$\text{TestLimits} = \text{TestValue} \pm \text{Specification}$
Trigger Sensitivity	CH 0, CH 1 <ul style="list-style-type: none"> <li>• <math>\text{TestLimits} = \text{TestValue} \pm 5\% \text{ FS up to } 10 \text{ MHz}</math></li> </ul> External Trigger <ul style="list-style-type: none"> <li>• <math>\text{TestLimits} = \text{TestValue} \pm 004 \text{ V up to } 10 \text{ MHz}</math></li> </ul>

**Table 179.** NI PXIe-5114 Test Limit Equations

Equation Type	Equations
Vertical Offset and Vertical Gain	$\text{TestLimits} = \text{TestValue} \pm (\text{TestValue} * 1.5\% \text{ of Input} + \text{Range} * 0.3\% \text{ of FS} + 200 \mu\text{V})$ <ul style="list-style-type: none"> <li>• Within <math>\pm 5</math> °C of self-calibration temperature</li> </ul>
Programmable Vertical Offset	$\text{TestLimits} = \text{TestValue} \pm 2\% \text{ of offset setting}$ <ul style="list-style-type: none"> <li>• Within <math>\pm 5</math> °C of self-calibration temperature</li> </ul>
Timing	$\text{TestLimits} = \text{Internal Clock} \pm 25 \text{ ppm}$

Equation Type	Equations
Bandwidth and Flatness	$\text{TestLimits} = \text{TestValue} \pm \text{Specification}$
Trigger Sensitivity	CH 0, CH 1 <ul style="list-style-type: none"> <li>• <math>\text{TestLimits} = \text{TestValue} \pm 5\% \text{ FS up to } 10 \text{ MHz}</math></li> </ul> External Trigger <ul style="list-style-type: none"> <li>• <math>\text{TestLimits} = \text{TestValue} \pm 004 \text{ V up to } 10 \text{ MHz}</math></li> </ul>

Table 180. NI PCI-5114 Test Limit Equations

Equation Type	Equations
Vertical Offset and Vertical Gain	$\text{TestLimits} = \text{TestValue} \pm (\text{TestValue} * 1.5\% \text{ of Input} + \text{Range} * 0.3\% \text{ of FS} + 280 \mu\text{V})$ <ul style="list-style-type: none"> <li>• Within <math>\pm 5 \text{ }^\circ\text{C}</math> of self-calibration temperature</li> </ul>
Programmable Vertical Offset	$\text{TestLimits} = \text{TestValue} \pm 2\% \text{ of offset setting}$ <ul style="list-style-type: none"> <li>• Within <math>\pm 5 \text{ }^\circ\text{C}</math> of self-calibration temperature</li> </ul>
Timing	$\text{TestLimits} = \text{Internal Clock} \pm 25 \text{ ppm}$
Bandwidth and Flatness	$\text{TestLimits} = \text{TestValue} \pm \text{Specification}$
Trigger Sensitivity	CH 0, CH 1 <ul style="list-style-type: none"> <li>• <math>\text{TestLimits} = \text{TestValue} \pm 5\% \text{ FS up to } 10 \text{ MHz}</math></li> </ul> External Trigger <ul style="list-style-type: none"> <li>• <math>\text{TestLimits} = \text{TestValue} \pm 004 \text{ V up to } 10 \text{ MHz}</math></li> </ul>

**Related concepts:**

- [Launching a Calibration Procedure](#)



## NI 5122/5124/5142 Calibration Procedure

Calibrate the PXI/PCI-5122/5124/5142 and PXIe-5122 using Calibration Executive.

### Calibration Executive Procedure Features

Verify Only ✓	Verify & Adjust ✓	Manual Mode ✓	Optional Adjust ✗
---------------	-------------------	---------------	-------------------

### Approximate Test Time

35 minutes

### Test Equipment

The following table lists the test equipment required to calibrate NI 5122/5124/5142 digitizers.

**Table 181.** Test equipment for calibrating the NI 5122/5124/5142

Instrument	Recommended Model	Parameter Measured	Minimum Requirements
Scope Calibrator	Fluke 9500B with Fluke 9510 Test Head	Vertical Gain	DC $\pm(0.025\% + 25 \mu\text{V})$ into 1 M $\Omega$ or 50 $\Omega$
		Bandwidth, Trigger Sensitivity	$\pm 2\%$ output amplitude flatness for leveled sine wave up to 150 MHz relative to 50 kHz into 1 M $\Omega$ or 50 $\Omega$
		Timing	$\pm 2$ ppm frequency accuracy
Chassis	PXI-1042, PXI-1042Q	—	Use with PXI modules
	PXIe-1062Q	—	Use with PXI Express modules
BNC Cable	—	—	50 $\Omega$ coaxial cable



**Note** The Calibration Executive procedure runs in automated mode if you use IVI-supported instruments.

## Test Conditions

The following setup and environmental conditions are required to ensure the NI 5122/5124/5142 meets published specifications.

- Always connect the calibrator test head directly to the input BNC of the digitizer, or use a short 50  $\Omega$  BNC coaxial cable if necessary.
- Keep connections to the module short. Long cables and wires can act as antennas, which can pick up extra noise that might affect measurements.
- Keep relative humidity between 10 and 90% non-condensing, or consult the digitizer hardware documentation for the optimum relative humidity.
- Maintain a temperature of  $23 \pm 5$  °C.
- Allow a warm-up time of at least 15 minutes to ensure that the measurement circuitry of the device is at a stable operating temperature.
- Plug the PXI/PXI Express chassis or PC and the calibrator into the same power strip to avoid ground loops.
- (PXI/PXI Express) Ensure that the PXI/PXI Express chassis fan speed is set to HIGH, that the fan filters are clean, and that the empty slots contain filler panels.

## Device Setup

1. Install the NI 5122/5124/5142 in the PXI/PXI Express chassis or the PC according to the instructions in the NI High-Speed Digitizers Getting Started Guide.
2. Configure the hardware using Measurement & Automation Explorer (MAX).
3. Launch the Calibration Executive procedure and complete the setup wizard.

## Using an Alternative Calibrator



**Note** The Fluke 9500B/Wavetek 9500 is the only oscilloscope calibrator currently supported through GPIB control. You can run the calibration procedure in manual mode if you have another type of oscilloscope calibrator.



**Note** The instructions provided by Calibration Executive for connecting the calibrator during external adjustment are specific to Fluke 9500B/Wavetek 9500 oscilloscope calibrators.

If you are using a calibrator other than a Fluke 9500B/Wavetek 9500, the procedure for connecting the calibrator is different. When the Connect Calibrator dialog box appears, complete the following steps instead:

1. Connect a 10 MHz, 1 V<sub>pp</sub> sine or square wave source to channel 0.
2. Connect the oscilloscope calibrator DC source to channel 1.
3. Click **Continue** and follow the remaining instructions provided by Calibration Executive.

## Reading the Calibration Report

For the NI 5122/5124/5142, the report database modifies the Bandwidth and Flatness tables to show input frequencies in a nonstandard format. The input frequencies used to test the device as-found are different from the input frequencies used to test the device as-left. These two separate frequencies are listed in the same cell of the table in the following format:

(Input Frequency As-Found)/(Input Frequency As-Left)



**Note** If the NI 5122/5124/5142 fails verification after the adjustment, return it to NI for repair or replacement.

## Test Limit Equations

The following test limits are derived from the published specifications.

NI PXI/PCI-5122

**Table 182.** NI PXI-5122 Test Limit Equations

Equation Type	Equation
Vertical Gain	$\text{TestLimits} = \text{TestValue} \pm 0.65\% \text{ of input}$ <ul style="list-style-type: none"> <li>• Within <math>\pm 5</math> °C of self-calibration temperature</li> </ul>
Vertical Offset	0.2 and 0.4 V <sub>pk-pk</sub> Range

Equation Type	Equation
	<ul style="list-style-type: none"> <li>• TestLimits = TestValue <math>\pm</math> 1.0 mV</li> <li>• Within <math>\pm 5</math> °C of self-calibration temperature</li> </ul> <p>1 V<sub>pk-pk</sub> Range</p> <ul style="list-style-type: none"> <li>• TestLimits = TestValue <math>\pm</math> 1.2 mV</li> <li>• Within <math>\pm 5</math> °C of self-calibration temperature</li> </ul> <p>2 V<sub>pk-pk</sub> Range</p> <ul style="list-style-type: none"> <li>• TestLimits = TestValue <math>\pm</math> 1.6 mV</li> <li>• Within <math>\pm 5</math> °C of self-calibration temperature</li> </ul> <p>4 and 10 V<sub>pk-pk</sub> Range</p> <ul style="list-style-type: none"> <li>• TestLimits = TestValue <math>\pm</math> 8.0 mV</li> <li>• Within <math>\pm 5</math> °C of self-calibration temperature</li> </ul> <p>20 V<sub>pk-pk</sub> Range (1 M<math>\Omega</math> only)</p> <ul style="list-style-type: none"> <li>• TestLimits = TestValue <math>\pm</math> 13.0 mV</li> <li>• Within <math>\pm 5</math> °C of self-calibration temperature</li> </ul>
Programmable Vertical Offset	<p>TestLimits = TestValue <math>\pm</math> 0.4% of offset setting</p> <ul style="list-style-type: none"> <li>• Within <math>\pm 5</math> °C of self-calibration temperature</li> </ul>
Timing	<p>TestLimits = TestValue <math>\pm</math> 25 ppm</p> <ul style="list-style-type: none"> <li>• Not Phase-Locked to Reference Clock</li> </ul>
Trigger Sensitivity	<p>TestLimits = TestValue <math>\pm</math> 2.5% FS up to 50 MHz, increasing to 5% FS at 100 MHz</p>
Trigger Sensitivity on EXT TRIG	<p>TestLimits = TestValue <math>\pm</math> 0.25 V<sub>pk-pk</sub> up to 100 MHz, increasing to 1 V<sub>pk-pk</sub> at 200 MHz</p>

Table 183. NI PXIe-5122 Test Limit Equations

Equation Type	Equation
Vertical Gain	<p>TestLimits = TestValue <math>\pm</math> 0.65% of input</p> <ul style="list-style-type: none"> <li>• Within <math>\pm 5</math> °C of self-calibration temperature</li> </ul>
Vertical Offset	<p>0.2 and 0.4 V<sub>pk-pk</sub> Range</p> <ul style="list-style-type: none"> <li>• TestLimits = TestValue <math>\pm</math> 1.0 mV</li> <li>• Within <math>\pm 5</math> °C of self-calibration temperature</li> </ul> <p>1 V<sub>pk-pk</sub> Range</p> <ul style="list-style-type: none"> <li>• TestLimits = TestValue <math>\pm</math> 1.2 mV</li> <li>• Within <math>\pm 5</math> °C of self-calibration temperature</li> </ul> <p>2 V<sub>pk-pk</sub> Range</p> <ul style="list-style-type: none"> <li>• TestLimits = TestValue <math>\pm</math> 1.6 mV</li> <li>• Within <math>\pm 5</math> °C of self-calibration temperature</li> </ul> <p>4 and 10 V<sub>pk-pk</sub> Range</p> <ul style="list-style-type: none"> <li>• TestLimits = TestValue <math>\pm</math> 8.0 mV</li> <li>• Within <math>\pm 5</math> °C of self-calibration temperature</li> </ul> <p>20 V<sub>pk-pk</sub> Range (1 M<math>\Omega</math> only)</p> <ul style="list-style-type: none"> <li>• TestLimits = TestValue <math>\pm</math> 13.0 mV</li> <li>• Within <math>\pm 5</math> °C of self-calibration temperature</li> </ul>
Programmable Vertical Offset	<p>TestLimits = TestValue <math>\pm</math> 0.4% of offset setting</p> <ul style="list-style-type: none"> <li>• Within <math>\pm 5</math> °C of self-calibration temperature</li> </ul>
Timing	<p>TestLimits = TestValue <math>\pm</math> 25 ppm</p> <ul style="list-style-type: none"> <li>• Not Phase-Locked to Reference Clock</li> </ul>
Trigger Sensitivity	<p>TestLimits = TestValue <math>\pm</math> 2.5% FS up to 50 MHz, increasing to 5% FS at 100 MHz</p>

Equation Type	Equation
Trigger Sensitivity on EXT TRIG	TestLimits = TestValue $\pm$ 0.25 V <sub>pk-pk</sub> up to 100 MHz, increasing to 1 V <sub>pk-pk</sub> at 200 MHz

Table 184. NI PCI-5122 Test Limit Equations

Equation Type	Equation
Vertical Gain	TestLimits = TestValue $\pm$ 0.65% of input <ul style="list-style-type: none"> <li>• Within <math>\pm 5</math> °C of self-calibration temperature</li> </ul>
Vertical Offset	0.2 and 0.4 V <sub>pk-pk</sub> Range <ul style="list-style-type: none"> <li>• TestLimits = TestValue <math>\pm</math> 2.0 mV</li> <li>• Within <math>\pm 5</math> °C of self-calibration temperature</li> </ul> 1 V <sub>pk-pk</sub> Range <ul style="list-style-type: none"> <li>• TestLimits = TestValue <math>\pm</math> 2.0 mV</li> <li>• Within <math>\pm 5</math> °C of self-calibration temperature</li> </ul> 2 V <sub>pk-pk</sub> Range <ul style="list-style-type: none"> <li>• TestLimits = TestValue <math>\pm</math> 2.0 mV</li> <li>• Within <math>\pm 5</math> °C of self-calibration temperature</li> </ul> 4 and 10 V <sub>pk-pk</sub> Range <ul style="list-style-type: none"> <li>• TestLimits = TestValue <math>\pm</math> 8.0 mV</li> <li>• Within <math>\pm 5</math> °C of self-calibration temperature</li> </ul> 20 V <sub>pk-pk</sub> Range (1 M $\Omega$ only) <ul style="list-style-type: none"> <li>• TestLimits = TestValue <math>\pm</math> 13.0 mV</li> <li>• Within <math>\pm 5</math> °C of self-calibration temperature</li> </ul>
Programmable Vertical Offset	TestLimits = TestValue $\pm$ 0.4% of offset setting <ul style="list-style-type: none"> <li>• Within <math>\pm 5</math> °C of self-calibration temperature</li> </ul>
Timing	TestLimits = TestValue $\pm$ 25 ppm

Equation Type	Equation
	<ul style="list-style-type: none"> <li>• Not Phase-Locked to Reference Clock</li> </ul>
Trigger Sensitivity	TestLimits = TestValue $\pm$ 2.5% FS up to 50 MHz, increasing to 5% FS at 100 MHz
Trigger Sensitivity on EXT TRIG	TestLimits = TestValue $\pm$ 0.25 V <sub>pk-pk</sub> up to 100 MHz, increasing to 1 V <sub>pk-pk</sub> at 200 MHz

Table 185. NI PXI-5124 Test Limit Equations

Equation Type	Equation
Vertical Gain	TestLimits = TestValue $\pm$ 0.65% of input <ul style="list-style-type: none"> <li>• Within <math>\pm 5</math> °C of self-calibration temperature</li> </ul>
Vertical Offset	0.2 and 0.4 V <sub>pk-pk</sub> Range <ul style="list-style-type: none"> <li>• TestLimits = TestValue <math>\pm</math> 1.3 mV</li> <li>• Within <math>\pm 5</math> °C of self-calibration temperature</li> </ul> 1 and 2 V <sub>pk-pk</sub> Range <ul style="list-style-type: none"> <li>• TestLimits = TestValue <math>\pm</math> 1.5 mV</li> <li>• Within <math>\pm 5</math> °C of self-calibration temperature</li> </ul> 4, 10, and 20 (1 M $\Omega$ only) V <sub>pk-pk</sub> Range <ul style="list-style-type: none"> <li>• TestLimits = TestValue <math>\pm</math> 10 mV</li> <li>• Within <math>\pm 5</math> °C of self-calibration temperature</li> </ul>
Programmable Vertical Offset	TestLimits = TestValue $\pm$ 0.4% of offset setting <ul style="list-style-type: none"> <li>• Within <math>\pm 5</math> °C of self-calibration temperature</li> </ul>
Timing	TestLimits = TestValue $\pm$ 25 ppm <ul style="list-style-type: none"> <li>• Not Phase-Locked to Reference Clock</li> </ul>
Trigger Sensitivity	TestLimits = TestValue $\pm$ 3.5% FS up to 50 MHz,

Equation Type	Equation
	increasing to 10% FS at 150 MHz
Trigger Sensitivity on EXT TRIG	TestLimits = TestValue $\pm$ 0.25 V <sub>pk-pk</sub> up to 100 MHz, increasing to 1 V <sub>pk-pk</sub> at 200 MHz

Table 186. NI PCI-5124 Test Limit Equations

Equation Type	Equation
Vertical Gain	TestLimits = TestValue $\pm$ 0.65% of input <ul style="list-style-type: none"> <li>• Within <math>\pm 5</math> °C of self-calibration temperature</li> </ul>
Vertical Offset	0.2 and 0.4 V <sub>pk-pk</sub> Range <ul style="list-style-type: none"> <li>• TestLimits = TestValue <math>\pm</math> 1.8 mV</li> <li>• Within <math>\pm 5</math> °C of self-calibration temperature</li> </ul> 1 and 2 V <sub>pk-pk</sub> Range <ul style="list-style-type: none"> <li>• TestLimits = TestValue <math>\pm</math> 2.1 mV</li> <li>• Within <math>\pm 5</math> °C of self-calibration temperature</li> </ul> 4, 10, and 20 (1 M $\Omega$ only) V <sub>pk-pk</sub> Range <ul style="list-style-type: none"> <li>• TestLimits = TestValue <math>\pm</math> 10 mV</li> <li>• Within <math>\pm 5</math> °C of self-calibration temperature</li> </ul>
Programmable Vertical Offset	TestLimits = TestValue $\pm$ 0.4% of offset setting <ul style="list-style-type: none"> <li>• Within <math>\pm 5</math> °C of self-calibration temperature</li> </ul>
Timing	TestLimits = TestValue $\pm$ 25 ppm <ul style="list-style-type: none"> <li>• Not Phase-Locked to Reference Clock</li> </ul>
Trigger Sensitivity	TestLimits = TestValue $\pm$ 3.5% FS up to 50 MHz, increasing to 10% FS at 150 MHz
Trigger Sensitivity on EXT TRIG	TestLimits = TestValue $\pm$ 0.25 V <sub>pk-pk</sub> up to 100 MHz, increasing to 1 V <sub>pk-pk</sub> at 200 MHz



Table 187. NI PXI-5142 Test Limit Equations

Equation Type	Equation
Vertical Gain	<p>TestLimits = TestValue <math>\pm</math> 0.65% of input</p> <ul style="list-style-type: none"> <li>• Within <math>\pm 5</math> °C of self-calibration temperature</li> </ul>
Vertical Offset	<p>0.2 and 0.4 V<sub>pk-pk</sub> Range</p> <ul style="list-style-type: none"> <li>• TestLimits = TestValue <math>\pm</math> 1.0 mV</li> <li>• Within <math>\pm 5</math> °C of self-calibration temperature</li> </ul> <p>1 V<sub>pk-pk</sub> Range</p> <ul style="list-style-type: none"> <li>• TestLimits = TestValue <math>\pm</math> 1.2 mV</li> <li>• Within <math>\pm 5</math> °C of self-calibration temperature</li> </ul> <p>2 V<sub>pk-pk</sub> Range</p> <ul style="list-style-type: none"> <li>• TestLimits = TestValue <math>\pm</math> 1.6 mV</li> <li>• Within <math>\pm 5</math> °C of self-calibration temperature</li> </ul> <p>4 and 10 V<sub>pk-pk</sub> Range</p> <ul style="list-style-type: none"> <li>• TestLimits = TestValue <math>\pm</math> 8.0 mV</li> <li>• Within <math>\pm 5</math> °C of self-calibration temperature</li> </ul> <p>20 V<sub>pk-pk</sub> Range (1 M<math>\Omega</math> only)</p> <ul style="list-style-type: none"> <li>• TestLimits = TestValue <math>\pm</math> 13.0 mV</li> <li>• Within <math>\pm 5</math> °C of self-calibration temperature</li> </ul>
Programmable Vertical Offset	<p>TestLimits = TestValue <math>\pm</math> 0.4% of offset setting</p> <ul style="list-style-type: none"> <li>• Within <math>\pm 5</math> °C of self-calibration temperature</li> </ul>
Timing	<p>TestLimits = TestValue <math>\pm</math> 25 ppm</p> <ul style="list-style-type: none"> <li>• Not Phase-Locked to Reference Clock</li> </ul>
Trigger Sensitivity	<p>TestLimits = TestValue <math>\pm</math> 2.5% FS up to 50 MHz, increasing to 5% FS at 100 MHz</p>

Equation Type	Equation
Trigger Sensitivity on EXT TRIG	TestLimits = TestValue $\pm$ 0.25 V <sub>pk-pk</sub> up to 100 MHz, increasing to 1 V <sub>pk-pk</sub> at 200 MHz

Table 188. NI PCI-5142 Test Limit Equations

Equation Type	Equation
Vertical Gain	TestLimits = TestValue $\pm$ 0.65% of input <ul style="list-style-type: none"> <li>• Within <math>\pm 5</math> °C of self-calibration temperature</li> </ul>
Vertical Offset	0.2 and 0.4 V <sub>pk-pk</sub> Range <ul style="list-style-type: none"> <li>• TestLimits = TestValue <math>\pm</math> 2.0 mV</li> <li>• Within <math>\pm 5</math> °C of self-calibration temperature</li> </ul> 1 V <sub>pk-pk</sub> Range <ul style="list-style-type: none"> <li>• TestLimits = TestValue <math>\pm</math> 2.0 mV</li> <li>• Within <math>\pm 5</math> °C of self-calibration temperature</li> </ul> 2 V <sub>pk-pk</sub> Range <ul style="list-style-type: none"> <li>• TestLimits = TestValue <math>\pm</math> 2.0 mV</li> <li>• Within <math>\pm 5</math> °C of self-calibration temperature</li> </ul> 4 and 10 V <sub>pk-pk</sub> Range <ul style="list-style-type: none"> <li>• TestLimits = TestValue <math>\pm</math> 8.0 mV</li> <li>• Within <math>\pm 5</math> °C of self-calibration temperature</li> </ul> 20 V <sub>pk-pk</sub> Range (1 M $\Omega$ only) <ul style="list-style-type: none"> <li>• TestLimits = TestValue <math>\pm</math> 13.0 mV</li> <li>• Within <math>\pm 5</math> °C of self-calibration temperature</li> </ul>
Programmable Vertical Offset	TestLimits = TestValue $\pm$ 0.4% of offset setting <ul style="list-style-type: none"> <li>• Within <math>\pm 5</math> °C of self-calibration temperature</li> </ul>
Timing	TestLimits = TestValue $\pm$ 25 ppm

Equation Type	Equation
	<ul style="list-style-type: none"> <li>• Not Phase-Locked to Reference Clock</li> </ul>
Trigger Sensitivity	TestLimits = TestValue $\pm$ 2.5% FS up to 50 MHz, increasing to 5% FS at 100 MHz
Trigger Sensitivity on EXT TRIG	TestLimits = TestValue $\pm$ 0.25 V <sub>pk-pk</sub> up to 100 MHz, increasing to 1 V <sub>pk-pk</sub> at 200 MHz

### Related concepts:

- [Automated Mode Versus Manual Mode](#)
- [Launching a Calibration Procedure](#)

## USB-5132/5133 Calibration Procedure

Calibrate the USB-5132/5133 using Calibration Executive.

### Calibration Executive Procedure Features

Verify Only ✓	Verify & Adjust ✓	Manual Mode ✓	Optional Adjust ✗
---------------	-------------------	---------------	-------------------

### Approximate Test Time

40 minutes

### Test Equipment

The following table lists the test equipment required for calibrating the USB-5132/5133.

**Table 189.** Test equipment for calibrating the USB-5132/5133

Required Equipment	Recommended Equipment	Parameter Measured	Minimum Requirements
Scope Calibrator	Fluke 9500B with Fluke	DC Accuracy,	Output Range: 20 V to -20 V into 1 M $\Omega$ DC Voltage Accuracy: DC $\pm$ 0.3% of output into 1 M $\Omega$

Required Equipment	Recommended Equipment	Parameter Measured	Minimum Requirements
	9530 Test Head	Adjustment	
		Bandwidth	Output Range: 0.032 Vpp to 5.5 Vpp into 50 $\Omega$ AC Voltage Accuracy: $\pm 2\%$ output amplitude flatness for leveled sine wave up to 50.1 MHz relative to 50 kHz into 50 $\Omega$
		Adjustment	1 kHz square wave Output Range: 1.65 Vpp to 8.5 Vpp into 1 M $\Omega$ Rise Time: 20 ns to 150 ns
		Timing Accuracy	11 MHz sine wave Output Range: 1 Vpp into 50 $\Omega$ Frequency Accuracy: $\pm 4$ ppm
DMM	PXI-4071	AC Amplitude Accuracy	Input Range: 0.03 Vpp to 25.0 Vpp AC Voltage Accuracy: 0.3% of input at 50 kHz
Function Generator	PXI-5421	AC Amplitude Accuracy	50 kHz sine wave Amplitude Range: 0.036 Vpp to 24 Vpp into 1 M $\Omega$
BNC T Connector	—	AC Amplitude Accuracy	50 $\Omega$

## Test Conditions

The following setup and environmental conditions are required to ensure the USB-5132/5133 meets published specifications.

- Always connect the calibrator test head directly to the input BNC on the digitizer, or use a short 50  $\Omega$  BNC coaxial cable if necessary. Long cables and wires act as antennas, picking up extra noise that can affect measurement.
- Keep relative humidity between 10 and 90% non-condensing, or consult the digitizer hardware specifications for the optimum relative humidity..
- Maintain an ambient temperature of  $23 \pm 5$  °C.
- Allow a warm-up time of at least 10 minutes after the NI-SCOPE driver is loaded. Unless manually disabled, the NI-SCOPE driver automatically loads with the operating system and enables the device. The warm-up time ensures that the measurement circuitry of the USB-5132/5133 is at a stable operating temperature.
- Install a heavy ground wire between the USB-5132/5133 ground lug and the signal

source ground.



**Note** You must connect the DUT ground to the signal generator ground for the AC Amplitude Accuracy test. Refer to the Ground Loop Noise topic in the NI High-Speed Digitizers Help for more information.

## Device Setup

1. Connect the USB-5132/5133 to the host PC according to the instructions in the NI High-Speed Digitizers Getting Started Guide.
2. Configure the hardware using Measurement & Automation Explorer (MAX).
3. Launch the Calibration Executive procedure and complete the setup wizard.



**Note** If the USB-5132/5133 module fails after calibration, return it to NI for repair or replacement.

## Test Limit Equations

The following test limits are derived from the published specifications.

**Table 190.** USB-5132/5133 Test Limit Equations

Equation Type	Equation
Vertical Offset	$\text{TestLimits} = \text{TestPoints} \pm (2\% \text{ of input} + 1\% \text{ FS} + 300 \mu\text{V})$
Vertical Gain	$\text{TestLimits} = \pm 2\% (\text{Error})$ <ul style="list-style-type: none"> <li>• <math>\text{Error} = [(\text{measured positive voltage} - \text{measured negative voltage}) / (\text{applied positive voltage} - \text{applied negative voltage})] * 100</math></li> </ul>
Programmable Vertical Offset	40 mV Range <ul style="list-style-type: none"> <li>• <math>\text{TestLimits} = \pm 5\% (\pm 2\text{mV})</math></li> </ul>

Equation Type	Equation
	All Other Ranges <ul style="list-style-type: none"> <li>• TestLimits = <math>\pm 2.5\%</math></li> </ul>
AC Amplitude Accuracy	TestLimits = $\pm 2\%$ (Error) <ul style="list-style-type: none"> <li>• Error = [(measured RMS voltage of 50 kHz sine wave – DMM measured RMS voltage of 50 kHz sine wave) / DMM measured RMS voltage of 50 kHz sine wave] * 100</li> </ul>
Timing Accuracy	TestLimits = $\pm 50$ ppm

### Related concepts:

- [Launching a Calibration Procedure](#)

## NI 5152/5153/5154 Calibration Procedure

Calibrate the PCI/PXI-5152/5153/5154 and PCI-5153EX using Calibration Executive.

### Calibration Executive Procedure Features

Verify Only ✓	Verify & Adjust ✓	Manual Mode ✓	Optional Adjust ✗
---------------	-------------------	---------------	-------------------

### Approximate Test Time

35 minutes

### Test Equipment

The following table lists the test equipment required for calibrating the NI 5152/5153/5154.

**Table 312.** Test equipment for calibrating the NI 5152/5153/5154

Required Equipment	Recommended Equipment	Parameter Measured	Minimum Requirements
Scope Calibrator	(NI 5152/5153) Fluke 9500B with Fluke 9510 Test Head  (NI 5154) Fluke 9500B/1100 with Fluke 9510 Test Head	DC Accuracy	DC $\pm$ (0.025% + 25 $\mu$ V) into 1 M $\Omega$ or 50 $\Omega$
		Bandwidth, Trigger Sensitivity	(NI 5152) $\pm$ 2% output amplitude flatness for leveled sine wave up to 300 MHz relative to 50 kHz into 50 $\Omega$ (NI 5153) $\pm$ 3% output amplitude flatness for leveled sine wave up to 500 MHz relative to 50 kHz into 50 $\Omega$ (NI 5154) $\pm$ 4% output amplitude flatness for leveled sine wave up to 1100 MHz relative to 50 kHz into 50 $\Omega$
		Timing	$\pm$ 2 ppm frequency accuracy
Function Generator	Agilent 33220A	Trigger Accuracy	$\pm$ 5% output amplitude flatness for leveled sine wave up to 10 V <sub>pk-pk</sub> and 11 MHz relative to 50 kHz into 50 $\Omega$
BNC Power Splitter	Mini-Circuits Power Splitter ZSC 2-1+	Trigger Accuracy	Insertion Loss: < 4 dB at 10 MHz Amplitude Imbalance: 0.2 dB
BNC Feedthrough Terminator	Pomona 4119	Trigger Accuracy	50 $\Omega$ Frequency Range: DC to 10.1 MHz VSWR: 1.1 at 10 MHz
BNC Cables (x3)	—	—	50 $\Omega$ , identical in length and cable material
PXI Chassis	PXI-1042,PXI-1042Q	—	Use for PXI modules



**Note** The Agilent 332xx are the only function generators supported in automated mode.

## Test Conditions

The following setup and environmental conditions are required to ensure the NI 5152/5153/5154 meets published specifications.

- Always connect the calibrator test head directly to the input BNC of the digitizer, or use a short 50  $\Omega$  BNC coaxial cable if necessary. Long cables and wires act as antennas, picking up extra noise that can affect measurements.

- Keep relative humidity between 10 and 90% non-condensing, or consult the digitizer hardware specifications for the optimum relative humidity.
- Maintain an ambient temperature of  $23 \pm 5$  °C.
- Allow a warm-up time of at least 15 minutes after the NI-SCOPE driver is loaded. Unless manually disabled, the NI-SCOPE driver automatically loads with the operating system and enables the device. The warm-up time ensures that the measurement circuitry of the NI 515x is at a stable operating temperature.
- Plug the PXI chassis or PC and the calibrator into the same power strip to avoid ground loops.
- (PXI) Ensure that the PXI chassis fan speed is set to HIGH, that the fan filters are clean, and that the empty slots contain filler panels. For more information, refer to the Maintain Forced Air Cooling Note to Users, which is available at [ni.com/docs](http://ni.com/docs).

## Device Setup

1. Install the NI 5152/5153/5154 in the PXI chassis or PC according to the instructions in the NI High-Speed Digitizers Getting Started Guide.
2. Configure the hardware using Measurement & Automation Explorer (MAX).
3. Launch the Calibration Executive procedure and complete the setup wizard.



**Note** If the NI 515x module fails after calibration, return it to NI for repair or replacement.

## Test Limit Equations

The following test limits are derived from the published specifications.

**Table 192.** NI 5152 Test Limit Equations

Equation Type	Equation
Vertical Gain	TestLimits = $\pm 1.26\%$ (Error) <ul style="list-style-type: none"> <li>• Error = <math>\{[(\text{measured positive voltage} - \text{measured negative voltage}) / (\text{applied positive voltage} - \text{applied negative voltage})] - 1\} * 100</math></li> </ul>



Equation Type	Equation
	<ul style="list-style-type: none"> <li>• Within <math>\pm 5^\circ\text{C}</math> of self-calibration temperature</li> </ul>
Vertical Offset	<p>Range <math>V_{pk-pk}</math> 0.1 to 1</p> <ul style="list-style-type: none"> <li>• TestLimits = TestValue <math>\pm</math> (1.0% of FS + 500 <math>\mu\text{V}</math>)               <ul style="list-style-type: none"> <li>◦ Within <math>\pm 5^\circ\text{C}</math> of self-calibration temperature</li> </ul> </li> </ul> <p>Range <math>V_{pk-pk}</math> 2 to 10</p> <ul style="list-style-type: none"> <li>• TestLimits = TestValue <math>\pm</math> (1.0% of FS + 5 mV)               <ul style="list-style-type: none"> <li>◦ Within <math>\pm 5^\circ\text{C}</math> of self-calibration temperature</li> </ul> </li> </ul>
Programmable Vertical Offset	<p>TestLimits = TestValue <math>\pm</math> 0.9% of offset settling</p> <ul style="list-style-type: none"> <li>• Within <math>\pm 5^\circ\text{C}</math> of self-calibration temperature</li> </ul>
Timing Accuracy	<p>Test Limits = <math>\begin{cases} 30, &amp; \text{TempDelta} \leq 3^\circ\text{C} \\ 7 * (\text{TempDelta} - 3) + 30, &amp; \text{TempDelta} \geq 3^\circ\text{C} \end{cases}</math></p>
Bandwidth	<p>TestLimits = TestValue <math>\pm</math> 3 dB</p> <ul style="list-style-type: none"> <li>• Filter off</li> <li>• Bandwidth for 0 to <math>30^\circ\text{C}</math></li> <li>• Reduce by 0.25% per <math>^\circ\text{C}</math> above <math>30^\circ\text{C}</math></li> </ul>
Trigger Accuracy	<p>CH 0, CH 1) TestLimits = <math>\pm 5\%</math></p> <p>(External Trigger) TestLimits = <math>\pm 10\%</math></p>
Trigger Sensitivity	<p>Fetch a waveform from the digitizer and set the timeout parameter to 2 seconds. If the digitizer does not time out during the test, the digitizer</p>

Equation Type	Equation
	has passed this portion of the verification, otherwise it has failed this verification step.

**Table 193.** NI 5153/5154 Test Limit Equations

Equation Type	Equation
Vertical Gain	<p>Range <math>V_{pk-pk}</math> 0.1 to 1</p> <ul style="list-style-type: none"> <li>• TestLimits = <math>\pm 2.2\%</math> (Error) <ul style="list-style-type: none"> <li>◦ Error = <math>\{[(\text{measured positive voltage} - \text{measured negative voltage}) / (\text{applied positive voltage} - \text{applied negative voltage})] - 1\} * 100</math></li> <li>◦ Within <math>\pm 5^\circ\text{C}</math> of self-calibration temperature</li> </ul> </li> </ul> <p>Range <math>V_{pk-pk}</math> 2 to 10</p> <ul style="list-style-type: none"> <li>• TestLimits = <math>\pm 2.9\%</math> (Error) <ul style="list-style-type: none"> <li>◦ Error = <math>\{[(\text{measured positive voltage} - \text{measured negative voltage}) / (\text{applied positive voltage} - \text{applied negative voltage})] - 1\} * 100</math></li> <li>◦ Within <math>\pm 5^\circ\text{C}</math> of self-calibration temperature</li> </ul> </li> </ul>
Vertical Offset	<p>TestLimits = TestValue <math>\pm</math> (1.8% of FS)</p> <ul style="list-style-type: none"> <li>• Within <math>\pm 5^\circ\text{C}</math> of self-calibration temperature</li> </ul>
Timing Accuracy	$\text{Test Limits} = \begin{cases} 30, & \text{TempDelta} \leq 3^\circ\text{C} \\ 7 * (\text{TempDelta} - 3) + 30, & \text{TempDelta} \geq 3^\circ\text{C} \end{cases}$
Bandwidth	<p>TestLimits = TestValue <math>\pm</math> 3 dB</p> <ul style="list-style-type: none"> <li>• Filter off</li> <li>• Bandwidth for 0 to <math>35^\circ\text{C}</math></li> <li>• Reduce by 0.22% per <math>^\circ\text{C}</math> above <math>35^\circ\text{C}</math></li> </ul>

Equation Type	Equation
Trigger Accuracy	(CH 0, CH 1) TestLimits = $\pm 5\%$  (External Trigger) TestLimits = $\pm 10\%$
Trigger Sensitivity	Fetch a waveform from the digitizer and set the timeout parameter to 2 seconds. If the digitizer does not time out during the test, the digitizer has passed this portion of the verification, otherwise it has failed this verification step.

### Related concepts:

- [Launching a Calibration Procedure](#)

## PXIe-5160/5162 Calibration Procedure

Calibrate the PXIe-5160/5162 2-channel and 4-channel modules using Calibration Executive.

### Calibration Executive Procedure Features

Verify Only ✓	Verify & Adjust ✓	Manual Mode ✓	Optional Adjust ✗
---------------	-------------------	---------------	-------------------

### Approximate Test Time

2-Channel	4-Channel
112 minutes	148 minutes

### Test Equipment

The following table lists the test equipment required for calibrating PXIe-5160/5162 modules.

Table 312. Test equipment for calibrating the PXIe-5160/5162

Instrument	Recommended Model	Specification	Requirements
Oscilloscope Calibrator	Fluke 9500B/600 with Fluke 9530 Active Head	<p>Verifications:</p> <ul style="list-style-type: none"> <li>• Timebase accuracy</li> <li>• DC accuracy</li> <li>• Input impedance</li> <li>• Input capacitance</li> </ul> <p>Adjustment</p>	<p>Sine Wave Amplitude Range: 0.9 <math>V_{pk-pk}</math> at 11 MHz into 50 <math>\Omega</math></p> <p>Sine Wave Frequency Accuracy: 0.25 ppm at 11 MHz</p> <p>Square Wave Amplitude Range: 0.5 <math>V_{pk-pk}</math> to 45 <math>V_{pk-pk}</math> into 1 M<math>\Omega</math>, symmetrical to ground (0V)</p> <p>Square Wave Frequency: 500 Hz</p> <p>Square Wave Aberrations: &lt;2% peak for first 500 ns</p> <p>DC Output Range: <math>\pm 2.5</math> V into 50 <math>\Omega</math>, <math>\pm 40</math> V into 1 M<math>\Omega</math></p> <p>DC Output Accuracy: <math>\pm(0.025\%</math> of output + 25 <math>\mu</math>V)</p> <p>Impedance measurement: <math>\pm 0.1\%</math> of reading at 50 <math>\Omega</math> and 1 M<math>\Omega</math></p> <p>Capacitance measurement: <math>\pm 2\%</math> of reading <math>\pm 0.25</math> pF</p>
DMM	PXI-4070/4071 or PXIe-4081	<p>Verifications:</p> <ul style="list-style-type: none"> <li>• AC Amplitude Accuracy</li> </ul>	<p>AC voltage accuracy at 50 kHz:</p> <ul style="list-style-type: none"> <li>• <math>\leq(0.09\%</math> of reading <math>\pm 0.04\%</math> of range) for test points &lt; 0.15 <math>V_{pk-pk}</math></li> <li>• <math>\leq(0.09\%</math> of reading <math>\pm 0.02\%</math> of range) for test points <math>\geq 0.35</math> <math>V_{pk-pk}</math></li> </ul> <p>AC Input Range: 0.1 <math>V_{pk-pk}</math> to 20 <math>V_{pk-pk}</math></p> <p>AC Input Impedance: <math>\geq 10</math> M<math>\Omega</math></p>

Instrument	Recommended Model	Specification	Requirements
			Bandwidth: $\geq 100$ kHz
Function Generator	PXI-5402/5406 or Agilent 33220A	Verifications: <ul style="list-style-type: none"> <li>AC Amplitude Accuracy</li> </ul>	Sine Wave Frequency: 50 kHz Sine Wave Amplitude Range: 0.1 $V_{pk-pk}$ to 3.5 $V_{pk-pk}$ into 50 $\Omega$ ; 0.1 $V_{pk-pk}$ to 20 $V_{pk-pk}$ into 1 $M\Omega$
BNC Tee (M-F-F)	Pasternack PE9174	Verifications: <ul style="list-style-type: none"> <li>AC Amplitude Accuracy</li> </ul>	Impedance: 50 $\Omega$
Double Banana Plug to BNC (F)	Pasternack PE9008	Verifications: <ul style="list-style-type: none"> <li>AC Amplitude Accuracy</li> </ul>	Impedance: 50 $\Omega$
BNC (m)-to-BNC (m) cable (x2)	Pasternack PE3087	Verifications: <ul style="list-style-type: none"> <li>AC Amplitude Accuracy</li> </ul>	1 meter maximum length
Power sensor	Rohde & Schwarz NRP-Z91 with NRP-Z4 USB adapter or Rohde & Schwarz NRP6A(N) with NRP-ZKU USB adapter or Rohde & Schwarz NRP18A(N) with NRP-ZKU USB adapter	Test system characterization Verifications: <ul style="list-style-type: none"> <li>Bandwidth</li> </ul>	Range: -26 dBm to 10 dBm Frequency range: <ul style="list-style-type: none"> <li>(5160) 50 kHz to 475.1 MHz</li> <li>(5162) 50 kHz to 1500.1 MHz</li> </ul> Absolute power accuracy: <ul style="list-style-type: none"> <li>(5160) <math>&lt;0.054</math> dB for 50 kHz to <math>&lt;100</math> MHz, <math>&lt;0.063</math> dB for 100 MHz to 475.1 MHz</li> </ul>

Instrument	Recommended Model	Specification	Requirements
			<ul style="list-style-type: none"> <li>• (5162) &lt;0.056 dB for 50 kHz to &lt;100 MHz, &lt;0.063 dB for 100 MHz to &lt;1500.1 MHz</li> </ul> <p>Relative power accuracy at -7 dBm:</p> <ul style="list-style-type: none"> <li>• (5160) &lt;0.023 dB for 50 kHz to &lt;100 MHz, &lt;0.023 dB for 100 MHz to 475.1 MHz</li> <li>• (5162) &lt;0.023 dB for 100 MHz to &lt;1500.1 MHz</li> </ul> <p>VSWR: ≤1.11:1</p>
Signal generator	Rohde & Schwarz SMA100A base unit with required frequency option SMA-B103 or Rohde & Schwarz SMA100B base unit with required frequency option SMAB-B103	Test system characterization  Verifications: <ul style="list-style-type: none"> <li>• Bandwidth</li> </ul>	Frequency range: <ul style="list-style-type: none"> <li>• (5160) 50 kHz to 475.1 MHz</li> <li>• (5162) 50 kHz to 1500.1 MHz</li> </ul> Frequency accuracy: ±100.0 ppm  Amplitude range: -20 dBm to 16 dBm  Harmonics: <-30 dBc
Power splitter*	Keysight 11667A or Aeroflex/Weinschel 1593	Test system characterization  Verifications: <ul style="list-style-type: none"> <li>• Bandwidth</li> </ul>	Frequency range: <ul style="list-style-type: none"> <li>• (5160) 50 kHz to 475.1 MHz</li> <li>• (5162) 50 kHz to 1500.1 MHz</li> </ul> VSWR: ≤1.10:1  Amplitude tracking: <0.5 dB
50 Ω BNC terminator (f)	Fairview Microwave ST3B-F	Test system characterization	Frequency range: <ul style="list-style-type: none"> <li>• (5160) DC to 475.1 MHz</li> <li>• (5162) DC to 1500.1 MHz</li> </ul>

Instrument	Recommended Model	Specification	Requirements
			VSWR: $\leq 1.25:1$ Impedance: $50 \Omega$
50 $\Omega$ BNC terminator (m)	Fairview Microwave ST2B	Verifications: <ul style="list-style-type: none"> <li>RMS noise</li> </ul>	Frequency range: <ul style="list-style-type: none"> <li>(5160) DC to 501 MHz</li> <li>(5162) DC to 1500.1 MHz</li> </ul> VSWR: $\leq 1.15:1$ Impedance: $50 \Omega$
Type N (m)-to-Type N (m) cable <sup>†</sup>	Maury Microwave SP-N-MM-24	Test system characterization Verifications: <ul style="list-style-type: none"> <li>Bandwidth</li> </ul>	Frequency range: <ul style="list-style-type: none"> <li>(5160) 50 kHz to 475.1 MHz</li> <li>(5162) 50 kHz to 1500.1 MHz</li> </ul> VSWR: $\leq 1.10:1$ Length: $\leq 1$ meter
SMA (m)-to-SMA (m) cable <sup>‡</sup>	—	Test system characterization Verifications: <ul style="list-style-type: none"> <li>Bandwidth</li> </ul>	Frequency range: <ul style="list-style-type: none"> <li>(5160) DC to 475.1 MHz</li> <li>(5162) DC to 1500.1 MHz</li> </ul> VSWR: $\leq 1.10:1$ Length: $\leq 1$ meter
Type N (m)-to-BNC (m) adapter (x2)	Maury Microwave 8821D1	Test system characterization Verifications: <ul style="list-style-type: none"> <li>Bandwidth</li> </ul>	Frequency range: <ul style="list-style-type: none"> <li>(5160) 50 kHz to 475.1 MHz</li> <li>(5162) 50 kHz to 1500.1 MHz</li> </ul> VSWR: $\leq 1.08:1$
SMA (f)-to-N (m) adapter	Fairview Microwave SM4226	Test system characterization	Frequency range:

Instrument	Recommended Model	Specification	Requirements
		Verifications: • Bandwidth	<ul style="list-style-type: none"> <li>• (5160) DC to 475.1 MHz</li> <li>• (5162) DC to 1500.1 MHz</li> </ul> VSWR: $\leq 1.05:1$ Impedance: 50 $\Omega$
BNC (f)-to-N (f) adapter	Fairview Microwave SM3526	Test system characterization Verifications: • Bandwidth	Frequency range: <ul style="list-style-type: none"> <li>• (5160) DC to 475.1 MHz</li> <li>• (5162) DC to 1500.1 MHz</li> </ul> VSWR: <ul style="list-style-type: none"> <li>• (5160) <math>\leq 1.20:1</math></li> <li>• (5162) <math>\leq 1.10:1</math></li> </ul> Impedance: 50 $\Omega$
SMA (m)-to-BNC (m) adapter (x2)	Fairview Microwave Sm4716	Test system characterization Verifications: • Bandwidth	Frequency range: <ul style="list-style-type: none"> <li>• (5160) DC to 475.1 MHz</li> <li>• (5162) DC to 1500.1 MHz</li> </ul> VSWR: $\leq 1.10:1$ Impedance: 50 $\Omega$
BNC feedthrough terminator	Pomona 4119-50	Test system characterization Verifications: • Bandwidth	Frequency range: DC to 300.1 MHz VSWR: <ul style="list-style-type: none"> <li>• <math>\leq 1.10:1</math> at <math>\leq 250</math> MHz</li> <li>• <math>\leq 1.20:1</math> at <math>&gt;250</math> MHz, <math>\leq 301</math> MHz</li> </ul> Impedance: 50 $\Omega$



## Note



- \* The Aeroflex/Weinschel 1593 must be verified to VSWR  $\leq 1.10:1$  from 50 kHz to 475.1 MHz (5160) or 1500.1 MHz (5162). This calibration procedure is written for the Keysight 11667A. If using the Aeroflex/Weinschel 1593, use the prescribed connectors and adapters in an analogous manner.
- † Required if using the Keysight 11667A.
- ‡ Required if using the Aeroflex/Weinschel 1593.

## Test Conditions

The following setup and environmental conditions are required to ensure the PXIe-5160/5162 devices meet published specifications.

- Keep connections to the device as short as possible. Long cables and wires act as antennas, picking up noise that can affect measurements.
- Verify that all connections to the device, including front panel connections, are secure.
- Use shielded copper wire for all cable connections to the device. Use twisted-pairs wire to eliminate noise and thermal offsets.
- Maintain an ambient temperature of  $23 \pm 3$  °C. The device temperature will be greater than the ambient temperature.
- Keep relative humidity between 10% and 90% noncondensing.
- Allow a warm up time of at least 15 minutes to ensure that the measurement circuitry is at a stable operating temperature.
- Ensure that the PXI Express chassis fan speed is set to HIGH, the fan filters are removed, and the empty slots contain PXI chassis slot blockers and filler panels. For more information, refer to the Maintain Forced-Air Cooling Note to Users document available at [ni.com/docs](http://ni.com/docs).
- Plug the chassis/PC and the test equipment into the same power strip to avoid ground loops.

## Device Setup

1. Install the module in the PXI chassis or PC according to the instructions in the NI High-Speed Digitizers Getting Started Guide.

2. Configure the hardware using Measurement & Automation Explorer (MAX).
3. Launch the Calibration Executive procedure and complete the setup wizard.

## Test Limit Equations

The following test limits are derived from published specifications.

**Table 195.** PXIe-5160/5162 Test Limit Equations

Equation Type	Equation
DC Accuracy	$\text{Accuracy} = \pm[(2\% \times  \text{Reading} - \text{Vertical Offset} ) + (1.4\% \times  \text{Vertical Offset} ) + (0.6\% \text{ of FS}) + 600 \mu\text{V}]$ <ul style="list-style-type: none"> <li>• where <ul style="list-style-type: none"> <li>◦ FS (Full Scale) = VerticalRange</li> </ul> </li> </ul>
AC Amplitude Accuracy	Accuracy = $\pm 0.5$ dB at 50 kHz
50 Ohm Bandwidth	Accuracy = -3 dB
1 MOhm Bandwidth	Accuracy = -3 dB
Timebase Accuracy	$\text{Timebase error} = (\text{F}_{\text{measured}} - (100 \times 10^6))/100$ <ul style="list-style-type: none"> <li>• where <ul style="list-style-type: none"> <li>◦ <math>\text{F}_{\text{measured}}</math> is the peak frequency from the Scope Calibrator measured by the NI 516x</li> </ul> </li> </ul>
Input Impedance	Input Impedance, typical 50 Ohm $\pm 1.5\%$ 1 MOhm $\pm 0.75\%$
Input Capacitance	Input capacitance, characteristic (1 MOhm input only) = 15 pF
RMS Noise	RMS noise (% of FS) = $(100 \times \sigma)/\text{Vertical range}$

Equation Type	Equation
	<ul style="list-style-type: none"> <li>• where <ul style="list-style-type: none"> <li>◦ <math>\sigma</math> is the standard deviation of the acquired waveform.</li> </ul> </li> <li>• At Input Impedance 50 Ohm and 1 MOhm: <ul style="list-style-type: none"> <li>◦ if Input Range (<math>V_{pk-pk}</math>) is 0.05 V = 0.26% of FS</li> <li>◦ if Input Range (<math>V_{pk-pk}</math>) is 0.1 V = 0.16% of FS</li> <li>◦ if Input Range (<math>V_{pk-pk}</math>) is 0.2 V to 5 V = 0.14% of FS <ul style="list-style-type: none"> <li>▪ where <ul style="list-style-type: none"> <li>▪ FS (Full Scale) = VerticalRange</li> </ul> </li> </ul> </li> </ul> </li> </ul>

## PXIe-5163 Calibration Procedure

Calibrate the PXIe-5163 using Calibration Executive.



**Hazardous Voltage** Avoid touching the connections when generating a high voltage (up to  $\pm 200$  VDC) from the Scope Calibrator. It is the responsibility of the system designer, integrator, installer, maintenance personnel, and service personnel to make sure that the module is used safely.

## Calibration Executive Procedure Features

Verify Only ✓	Verify & Adjust ✓	Manual Mode ✓	Optional Adjust ✗
---------------	-------------------	---------------	-------------------

## Approximate Test Time

Verify Only	Adjust Only	Verify & Adjust
20 minutes	22 minutes	50 minutes

## Test Equipment

The following table lists the test equipment required to calibrate PXIe-5163.

**Table 312.** Test equipment for calibrating the PXIe-5163

Instrument	Recommended Model	Where Used	Minimum Requirements
Oscilloscope calibrator	Fluke 9500B/600 with Fluke 9530 Active Head	Verifications: <ul style="list-style-type: none"> <li>• Timebase accuracy</li> <li>• DC accuracy</li> </ul> Adjustment	Sine wave generation: <ul style="list-style-type: none"> <li>• Amplitude: <math>0.9 V_{pk-pk}</math> into <math>50 \Omega</math></li> <li>• Frequency: 11 MHz and 99 MHz</li> <li>• Frequency accuracy: <math>\pm 0.25</math> ppm</li> </ul>
			Square wave generation: <ul style="list-style-type: none"> <li>• Amplitude: <math>0.5 V_{pk-pk}</math> to <math>45 V_{pk-pk}</math> into <math>1 M\Omega</math> symmetrical to ground (0 V)</li> <li>• Frequency: 500 Hz</li> <li>• Abberations: &lt;2% of peak for the first 500 ns</li> </ul>
			DC generation: <ul style="list-style-type: none"> <li>• Amplitude: <math>\pm 2.5</math> V into <math>50 \Omega</math>, <math>\pm 200</math> V into <math>1 M\Omega</math></li> <li>• Accuracy: <math>\pm(0.025\%</math> of output + <math>25 \mu V</math>)</li> </ul>
DMM	PXI-4071 or PXIe-4081	Verifications: <ul style="list-style-type: none"> <li>• AC amplitude accuracy</li> </ul>	AC voltage measurement: <ul style="list-style-type: none"> <li>• Range: <math>0.125 V_{pk-pk}</math> to <math>20 V_{pk-pk}</math></li> <li>• Input impedance: <math>\geq 10 M\Omega</math></li> <li>• Bandwidth: <math>\geq 50</math> kHz</li> <li>• Accuracy at 50 kHz:               <ul style="list-style-type: none"> <li>◦ <math>\pm(0.07\%</math> of reading +</li> </ul> </li> </ul>

Instrument	Recommended Model	Where Used	Minimum Requirements
			<p>14 <math>\mu\text{V}</math>) for 0.125 V<sub>pk-pk</sub> test point</p> <ul style="list-style-type: none"> <li>◦ <math>\pm(0.06\%</math> of reading + 71 <math>\mu\text{V}</math>) for 0.25 V<sub>pk-pk</sub> to 1.25 V<sub>pk-pk</sub> test points</li> <li>◦ <math>\pm(0.06\%</math> of reading + 707 <math>\mu\text{V}</math>) for 2.5 V<sub>pk-pk</sub> to 12.5 V<sub>pk-pk</sub> test points</li> <li>◦ <math>\pm(0.12\%</math> of reading + 35 mV) for 20.0 V<sub>pk-pk</sub> test point</li> </ul>
Function generator	PXI-5402/5406 or Agilent 33220A	<p>Verifications:</p> <ul style="list-style-type: none"> <li>• AC amplitude accuracy</li> </ul>	<p>Sine wave generation:</p> <ul style="list-style-type: none"> <li>• Amplitude: <ul style="list-style-type: none"> <li>◦ 0.125 V<sub>pk-pk</sub> to 2.5 V<sub>pk-pk</sub> into 50 <math>\Omega</math></li> <li>◦ 0.125 V<sub>pk-pk</sub> to 20 V<sub>pk-pk</sub> into 1 M<math>\Omega</math></li> </ul> </li> <li>• Frequency: 50 kHz</li> </ul>
BNC Tee (m-f-f)	Pasternack PE9174	<p>Verifications:</p> <ul style="list-style-type: none"> <li>• AC amplitude accuracy</li> </ul>	Impedance: 50 $\Omega$
Double banana plug to BNC (f)	Pasternack PE9008	<p>Verifications:</p> <ul style="list-style-type: none"> <li>• AC amplitude accuracy</li> </ul>	Impedance: 50 $\Omega$
BNC (m)-to-BNC (m) cable (x2)	Pasternack PE308	<p>Verifications:</p> <ul style="list-style-type: none"> <li>• AC amplitude accuracy</li> </ul>	Length: $\leq 1$ meter
Power sensor	Rohde & Schwarz	Test system	Power measurement:

Instrument	Recommended Model	Where Used	Minimum Requirements
	NRP-Z91 or NRP18A(N)	characterization  Adjustment  Verifications: <ul style="list-style-type: none"> <li>• Passband amplitude flatness and bandwidth</li> </ul>	<ul style="list-style-type: none"> <li>• Frequency range: 50 kHz to 495.1 MHz</li> <li>• Power range: -16 dBm to 10 dBm</li> <li>• VSWR: <math>\leq 1.11:1</math></li> <li>• Absolute accuracy:                             <ul style="list-style-type: none"> <li>◦ <math>&lt; 0.048</math> dB for 50 kHz to <math>&lt; 100</math> MHz</li> <li>◦ <math>&lt; 0.063</math> dB for 100 MHz to 495.1 MHz</li> </ul> </li> <li>• Relative accuracy at -4 dBm:                             <ul style="list-style-type: none"> <li>◦ <math>&lt; 0.022</math> dB for 50 kHz to <math>&lt; 100</math> MHz</li> <li>◦ <math>&lt; 0.022</math> dB for 100 MHz to 495.1 MHz</li> </ul> </li> </ul>
Signal generator	Rohde & Schwarz SMA100A	Test system characterization  Adjustment  Verifications: <ul style="list-style-type: none"> <li>• Passband amplitude flatness and bandwidth</li> </ul>	Sine wave generation: <ul style="list-style-type: none"> <li>• Amplitude: -10 dBm to 16 dBm</li> <li>• Frequency: 50 kHz to 495.1 MHz</li> <li>• Harmonics: <math>&lt; -30</math> dBc</li> <li>• Frequency accuracy: <math>\pm 100.0</math> ppm</li> </ul>
Power splitter*	Keysight 11667A or Aeroflex/Weinschel 1593	Test system characterization  Adjustment  Verifications: <ul style="list-style-type: none"> <li>• Passband amplitude flatness and</li> </ul>	<ul style="list-style-type: none"> <li>• Amplitude: -16 dBm to 16 dBm</li> <li>• Frequency: 50 kHz to 495.1 MHz</li> <li>• VSWR: <math>\leq 1.10:1</math></li> </ul>

Instrument	Recommended Model	Where Used	Minimum Requirements
		bandwidth	
50 Ω BNC terminator (f)	Fairview Microwave ST3B-F	Test system characterization	<ul style="list-style-type: none"> <li>• Amplitude: 10 dBm</li> <li>• Frequency: DC to 495.1 MHz</li> <li>• VSWR: ≤1.25:1</li> </ul>
50 Ω BNC terminator (m)	Fairview Microwave ST2B	Verifications: <ul style="list-style-type: none"> <li>• RMS noise</li> </ul>	<ul style="list-style-type: none"> <li>• Frequency: DC to 495.1 MHz</li> <li>• VSWR: ≤1.15:1</li> </ul>
Type N (m)-to-Type N (m) cable <sup>†</sup>	Maury Microwave SP-N-MM-24	Test system characterization  Adjustment  Verifications: <ul style="list-style-type: none"> <li>• Passband amplitude flatness and bandwidth</li> </ul>	<ul style="list-style-type: none"> <li>• Frequency: DC to 495.1 MHz</li> <li>• VSWR: ≤1.10:1</li> <li>• Length: ≤1 meter</li> </ul>
SMA (m)-to-SMA (m) cable	—	Test system characterization  Adjustment  Verifications: <ul style="list-style-type: none"> <li>• Passband amplitude flatness and bandwidth</li> </ul>	<ul style="list-style-type: none"> <li>• Frequency: DC to 495.1 MHz</li> <li>• VSWR: ≤1.10:1</li> <li>• Length: ≤1 meter</li> </ul>
Type N (m)-to-BNC (m) adapter (x2) <sup>†</sup>	Maury Microwave 8821D1	Test system characterization	<ul style="list-style-type: none"> <li>• Frequency: DC to 495.1 MHz</li> <li>• VSWR: ≤1.08:1</li> </ul>

Instrument	Recommended Model	Where Used	Minimum Requirements
		Adjustment  Verifications: <ul style="list-style-type: none"> <li>• Passband amplitude flatness and bandwidth</li> </ul>	
SMA (f)-to-N (m) adapter‡	Fairview Microwave SM4226	Test system characterization  Adjustment  Verifications: <ul style="list-style-type: none"> <li>• Passband amplitude flatness and bandwidth</li> </ul>	<ul style="list-style-type: none"> <li>• Frequency: DC to 495.1 MHz</li> <li>• VSWR: <math>\leq 1.05:1</math></li> </ul>
BNC (f)-to-N (f) adapter	Fairview Microwave SM3526	Test system characterization  Adjustment  Verifications: <ul style="list-style-type: none"> <li>• Passband amplitude flatness and bandwidth</li> </ul>	<ul style="list-style-type: none"> <li>• Frequency: DC to 495.1 MHz</li> <li>• VSWR: <math>\leq 1.10:1</math></li> <li>• Impedance: 50 <math>\Omega</math></li> </ul>
SMA (m)-to-BNC (m) adapter (x2)‡	Fairview Microwave SM4716	Test system characterization  Adjustment  Verifications:	<ul style="list-style-type: none"> <li>• Frequency: DC to 495.1 MHz</li> <li>• VSWR: <math>\leq 1.10:1</math></li> <li>• Impedance: 50 <math>\Omega</math></li> </ul>



Instrument	Recommended Model	Where Used	Minimum Requirements
		<ul style="list-style-type: none"> <li>Passband amplitude flatness and bandwidth</li> </ul>	
BNC feed-thru terminator <sup>†</sup>	Pomona 4119-50	Adjustment Verifications: <ul style="list-style-type: none"> <li>Bandwidth</li> </ul>	<ul style="list-style-type: none"> <li>Amplitude: 10 dBm</li> <li>Frequency: 50 kHz to 301 MHz</li> <li>VSWR:               <ul style="list-style-type: none"> <li>≤1.10:1 at ≤250 MHz</li> <li>≤1.20:1 at &gt;250 MHz, ≤301 MHz</li> </ul> </li> <li>Impedance: 50 Ω</li> </ul>
SMA feed-thru terminator‡	Pasternack PE6026	Adjustment Verifications: <ul style="list-style-type: none"> <li>Passband amplitude flatness and bandwidth</li> </ul>	<ul style="list-style-type: none"> <li>Amplitude: 10 dBm</li> <li>Frequency: 50 kHz to 301 MHz</li> <li>VSWR: ≤1.25:1 at ≤301 MHz</li> <li>Impedance: 50 Ω</li> </ul>



## Note

- \* The Aeroflex/Weinschel 1593 must be verified to VSWR ≤1.10:1 from 50 kHz to 495.1 MHz. This calibration procedure is written for the Keysight 11667A. If using the Aeroflex/Weinschel 1593, use the prescribed connectors and adapters in an analogous manner.
- <sup>†</sup> Required if using the Keysight 11667A.
- <sup>‡</sup> Required if using the Aeroflex/Weinschel 1593.

## Test Conditions

The following setup and environmental conditions are required to ensure the PXIe-5163 meets published specifications.

- Ensure that the PXI chassis fan speed is set to HIGH, that the fan filters are clean, and that the empty slots contain filler panels. For more information about cooling, refer to the ***Maintain Forced-Air Cooling Note to Users*** document available at [ni.com/docs](http://ni.com/docs).
- Plug the PXI chassis and the calibrator into the same power strip to avoid ground loops.
- Allow a warm-up time of at least 15 minutes after the chassis is powered on. The warm-up time ensures that the module is at a stable operating temperature.
- Allow a warm-up time for all of the instruments and equipment according to the manufacturer instructions.
- Maintain an ambient temperature of  $23\text{ }^{\circ}\text{C} \pm 3\text{ }^{\circ}\text{C}$ .
- Keep relative humidity between 10% and 90%, noncondensing.
- Keep cabling as short as possible. Long cables act as antennas, picking up extra noise that can affect measurements.
- Verify that all connections to the PXIe-5163, including front panel connections and screws, are secure.
- Use shielded copper wire for all cable connections to the device. Use twisted-pair wire to eliminate noise and thermal offsets.

## Device Setup

1. Install the PXIe-5163 in the PXI chassis according to the instructions in the PXIe-5163 Getting Started Guide, which is available at [ni.com/docs](http://ni.com/docs).
2. Configure the hardware using Measurement & Automation Explorer (MAX).
3. Launch the Calibration Executive procedure and complete the setup wizard.

## Test Limit Equations

The following test limits are derived from the published specifications.

**Table 197.** PXIe-5153 50  $\Omega$  Input Impedance Test Limit Equations

Equation Type	Equation
DC Accuracy	Accuracy = $\pm[(0.5\% \times  \text{Reading} ) + (0.2\% \text{ of FS})]$
AC Amplitude Accuracy	Accuracy = $\pm 0.2$ dB at 50 kHz
Amplitude Passband Flatness Bandwidth	Accuracy = -3 dB <ul style="list-style-type: none"> <li>Accuracy = <math>\pm 0.5</math> dB from 50 kHz to 330 MHz</li> </ul>
Timebase Accuracy	Accuracy = $\pm 5.0$ ppm
RMS Noise	<p>if Vertical Range (<math>V_{pk-pk}</math>) is 0.25 = 0.045 % of FS</p> <p>if Vertical Range (<math>V_{pk-pk}</math>) is 0.5 = 0.050 % of FS</p> <p>if Vertical Range (<math>V_{pk-pk}</math>) is 1 = 0.035 % of FS</p> <p>if Vertical Range (<math>V_{pk-pk}</math>) is 2.5 = 0.030 % of FS</p> <p>if Vertical Range (<math>V_{pk-pk}</math>) is 5 = 0.030 % of FS</p>

**Table 198.** PXIe-5153 1 M $\Omega$  Input Impedance Test Limit Equations

Equation Type	Equation
DC Accuracy	Accuracy = $\pm[(0.65\% \times  \text{Reading} - \text{Vertical Offset} ) + (0.4\% \times  \text{Vertical Offset} ) + (0.2\% \text{ of FS}) + 0.15 \text{ mV}]$
AC Amplitude Accuracy	Accuracy = $\pm 0.2$ dB at 50 kHz
Amplitude Passband Flatness Bandwidth	Accuracy = -3 dB <ul style="list-style-type: none"> <li>Accuracy = <math>\pm 0.7</math> dB from 50 kHz to 200 MHz</li> </ul>
Timebase Accuracy	Accuracy = $\pm 5.0$ ppm
RMS Noise	<p>if Vertical Range (<math>V_{pk-pk}</math>) is 0.25 = 0.110 % of FS</p> <p>if Vertical Range (<math>V_{pk-pk}</math>) is 0.5 = 0.060 % of FS</p> <p>if Vertical Range (<math>V_{pk-pk}</math>) is 1 = 0.050 % of FS</p>

Equation Type	Equation
	if Vertical Range ( $V_{pk-pk}$ ) is 2.5 = 0.100 % of FS
	if Vertical Range ( $V_{pk-pk}$ ) is 5 = 0.060 % of FS
	if Vertical Range ( $V_{pk-pk}$ ) is 10 = 0.050 % of FS
	if Vertical Range ( $V_{pk-pk}$ ) is 25 = 0.080 % of FS
	if Vertical Range ( $V_{pk-pk}$ ) is 50 = 0.060 % of FS
	if Vertical Range ( $V_{pk-pk}$ ) is 100 = 0.050 % of FS

**Related concepts:**

- [Launching a Calibration Procedure](#)

## PXIe-5164 Calibration Procedure

Calibrate the PXIe-5164 using Calibration Executive.



**Hazardous Voltage** Avoid touching the connections when generating a high voltage (up to  $\pm 200$  VDC) from the Scope Calibrator. It is the responsibility of the system designer, integrator, installer, maintenance personnel, and service personnel to make sure that the module is used safely.

### Calibration Executive Procedure Features

Verify Only ✓	Verify & Adjust ✓	Manual Mode ✓	Optional Adjust ✗
---------------	-------------------	---------------	-------------------

### Approximate Test Time

Verify Only	Adjust Only	Verify & Adjust
30 minutes	35 minutes	85 minutes

## Test Equipment

The following table lists the test equipment required to calibrate PXIe-5164.

**Table 312.** Test equipment for calibrating the PXIe-5164

Instrument	Recommended Model	Where Used	Minimum Requirements
Oscilloscope calibrator	Fluke 9500B/600 with Fluke 9530 Active Head	Verifications: <ul style="list-style-type: none"> <li>• Timebase accuracy</li> <li>• DC accuracy</li> </ul> Adjustment	Sine wave generation: <ul style="list-style-type: none"> <li>• Amplitude: 0.9 V<sub>pk-pk</sub> into 50 Ω</li> <li>• Frequency: 11 MHz and 99 MHz</li> <li>• Frequency accuracy: ±0.25 ppm</li> </ul>
			Square wave generation: <ul style="list-style-type: none"> <li>• Amplitude: 0.5 V<sub>pk-pk</sub> to 45 V<sub>pk-pk</sub> into 1 MΩ symmetrical to ground (0 V)</li> <li>• Frequency: 500 Hz</li> <li>• Abberations: &lt;2% of peak for the first 500 ns</li> </ul>
			DC generation: <ul style="list-style-type: none"> <li>• Amplitude: ±2.5 V into 50 Ω, ±200 V into 1 MΩ</li> <li>• Accuracy: ±(0.025% of output + 25 μV)</li> </ul>
DMM	PXI-4071 orPXIe-4081	Verifications: <ul style="list-style-type: none"> <li>• AC amplitude accuracy</li> </ul>	AC voltage measurement: <ul style="list-style-type: none"> <li>• Range: 0.125 V<sub>pk-pk</sub> to 20 V<sub>pk-pk</sub></li> <li>• Input impedance: ≥10 MΩ</li> <li>• Bandwidth: ≥50 kHz</li> </ul>

Instrument	Recommended Model	Where Used	Minimum Requirements
			<ul style="list-style-type: none"> <li>• Accuracy at 50 kHz:               <ul style="list-style-type: none"> <li>◦ <math>\pm(0.07\%</math> of reading + 14 <math>\mu\text{V}</math>) for 0.125 V<sub>pk-pk</sub> test point</li> <li>◦ <math>\pm(0.06\%</math> of reading + 71 <math>\mu\text{V}</math>) for 0.25 V<sub>pk-pk</sub> to 1.25 V<sub>pk-pk</sub> test points</li> <li>◦ <math>\pm(0.06\%</math> of reading + 707 <math>\mu\text{V}</math>) for 2.5 V<sub>pk-pk</sub> to 12.5 V<sub>pk-pk</sub> test points</li> <li>◦ <math>\pm(0.12\%</math> of reading + 35 mV) for 20.0 V<sub>pk-pk</sub> test point</li> </ul> </li> </ul>
Function generator	PXI-5402/5406 or Agilent 33220A	Verifications: <ul style="list-style-type: none"> <li>• AC amplitude accuracy</li> </ul>	Sine wave generation: <ul style="list-style-type: none"> <li>• Amplitude:               <ul style="list-style-type: none"> <li>◦ 0.125 V<sub>pk-pk</sub> to 2.5 V<sub>pk-pk</sub> into 50 <math>\Omega</math></li> <li>◦ 0.125 V<sub>pk-pk</sub> to 20 V<sub>pk-pk</sub> into 1 M<math>\Omega</math></li> </ul> </li> <li>• Frequency: 50 kHz</li> </ul>
BNC Tee (m-f)	Pasternack PE9174	Verifications: <ul style="list-style-type: none"> <li>• AC amplitude accuracy</li> </ul>	Impedance: 50 $\Omega$
Double banana plug to BNC (f)	Pasternack PE9008	Verifications: <ul style="list-style-type: none"> <li>• AC amplitude accuracy</li> </ul>	Impedance: 50 $\Omega$
BNC (m)-to-BNC (m) cable (x2)	Pasternack PE308	Verifications: <ul style="list-style-type: none"> <li>• AC amplitude</li> </ul>	Length: $\leq 1$ meter

Instrument	Recommended Model	Where Used	Minimum Requirements
		accuracy	
Power sensor	Rohde & Schwarz NRP-Z91 or Rohde & Schwarz NRP18A(N)	<p>Test system characterization</p> <p>Adjustment</p> <p>Verifications:</p> <ul style="list-style-type: none"> <li>• Passband amplitude flatness and bandwidth</li> </ul>	<p>Power measurement:</p> <ul style="list-style-type: none"> <li>• Frequency range: 50 kHz to 495.1 MHz</li> <li>• Power range: -16 dBm to 10 dBm</li> <li>• VSWR: <math>\leq 1.11:1</math></li> <li>• Absolute accuracy: <ul style="list-style-type: none"> <li>◦ <math>&lt; 0.048</math> dB for 50 kHz to <math>&lt; 100</math> MHz</li> <li>◦ <math>&lt; 0.063</math> dB for 100 MHz to 495.1 MHz</li> </ul> </li> <li>• Relative accuracy at -4 dBm: <ul style="list-style-type: none"> <li>◦ <math>&lt; 0.022</math> dB for 50 kHz to <math>&lt; 100</math> MHz</li> <li>◦ <math>&lt; 0.022</math> dB for 100 MHz to 495.1 MHz</li> </ul> </li> </ul>
Signal generator	Rohde & Schwarz SMA100A base unit with required frequency option SMA-B103	<p>Test system characterization</p> <p>Adjustment</p> <p>Verifications:</p> <ul style="list-style-type: none"> <li>• Passband amplitude flatness and bandwidth</li> </ul>	<p>Sine wave generation:</p> <ul style="list-style-type: none"> <li>• Amplitude: -10 dBm to 16 dBm</li> <li>• Frequency: 50 kHz to 495.1 MHz</li> <li>• Harmonics: <math>&lt; -30</math> dBc</li> <li>• Frequency accuracy: <math>\pm 100.0</math> ppm</li> </ul>
Power splitter*	Keysight 11667A or Aeroflex/Weinschel 1593	<p>Test system characterization</p> <p>Adjustment</p>	<ul style="list-style-type: none"> <li>• Amplitude: -16 dBm to 16 dBm</li> <li>• Frequency: 50 kHz to</li> </ul>

Instrument	Recommended Model	Where Used	Minimum Requirements
		Verifications: <ul style="list-style-type: none"> <li>Passband amplitude flatness and bandwidth</li> </ul>	<ul style="list-style-type: none"> <li>495.1 MHz</li> <li>VSWR: <math>\leq 1.10:1</math></li> </ul>
50 $\Omega$ BNC terminator (f)	Fairview Microwave ST3B-F	Test system characterization	<ul style="list-style-type: none"> <li>Amplitude: 10 dBm</li> <li>Frequency: DC to 495.1 MHz</li> <li>VSWR: <math>\leq 1.25:1</math></li> </ul>
50 $\Omega$ BNC terminator (m)	Fairview Microwave ST2B	Verifications: <ul style="list-style-type: none"> <li>RMS noise</li> </ul>	<ul style="list-style-type: none"> <li>Frequency: DC to 495.1 MHz</li> <li>VSWR: <math>\leq 1.15:1</math></li> </ul>
Type N (m)-to-Type N (m) cable <sup>†</sup>	Maury Microwave SP-N-MM-24	Test system characterization  Adjustment  Verifications: <ul style="list-style-type: none"> <li>Passband amplitude flatness and bandwidth</li> </ul>	<ul style="list-style-type: none"> <li>Frequency: DC to 495.1 MHz</li> <li>VSWR: <math>\leq 1.10:1</math></li> <li>Length: <math>\leq 1</math> meter</li> </ul>
SMA (m)-to-SMA (m) cable <sup>‡</sup>	—	Test system characterization  Adjustment  Verifications: <ul style="list-style-type: none"> <li>Passband amplitude flatness and</li> </ul>	<ul style="list-style-type: none"> <li>Frequency: DC to 495.1 MHz</li> <li>VSWR: <math>\leq 1.10:1</math></li> <li>Length: <math>\leq 1</math> meter</li> </ul>



Instrument	Recommended Model	Where Used	Minimum Requirements
		bandwidth	
Type N (m)-to-BNC (m) adapter (x2) <sup>†</sup>	Maury Microwave 8821D1	<p>Test system characterization</p> <p>Adjustment</p> <p>Verifications:</p> <ul style="list-style-type: none"> <li>Passband amplitude flatness and bandwidth</li> </ul>	<ul style="list-style-type: none"> <li>Frequency: DC to 495.1 MHz</li> <li>VSWR: <math>\leq 1.08:1</math></li> </ul>
SMA (f)-to-N (m) adapter <sup>‡</sup>	Fairview Microwave SM4226	<p>Test system characterization</p> <p>Adjustment</p> <p>Verifications:</p> <ul style="list-style-type: none"> <li>Passband amplitude flatness and bandwidth</li> </ul>	<ul style="list-style-type: none"> <li>Frequency: DC to 495.1 MHz</li> <li>VSWR: <math>\leq 1.05:1</math></li> </ul>
BNC (f)-to-N (f) adapter	Fairview Microwave SM3526	<p>Test system characterization</p> <p>Adjustment</p> <p>Verifications:</p> <ul style="list-style-type: none"> <li>Passband amplitude flatness and bandwidth</li> </ul>	<ul style="list-style-type: none"> <li>Frequency: DC to 495.1 MHz</li> <li>VSWR: <math>\leq 1.10:1</math></li> <li>Impedance: 50 <math>\Omega</math></li> </ul>

Instrument	Recommended Model	Where Used	Minimum Requirements
SMA (m)-to-BNC (m) adapter (x2)‡	Fairview Microwave SM4716	<p>Test system characterization</p> <p>Adjustment</p> <p>Verifications:</p> <ul style="list-style-type: none"> <li>• Passband amplitude flatness and bandwidth</li> </ul>	<ul style="list-style-type: none"> <li>• Frequency: DC to 495.1 MHz</li> <li>• VSWR: <math>\leq 1.10:1</math></li> <li>• Impedance: 50 <math>\Omega</math></li> </ul>
BNC feed-thru terminator†	Pomona 4119-50	<p>Adjustment</p> <p>Verifications:</p> <ul style="list-style-type: none"> <li>• Passband amplitude flatness and bandwidth</li> </ul>	<ul style="list-style-type: none"> <li>• Amplitude: 10 dBm</li> <li>• Frequency: 50 kHz to 301 MHz</li> <li>• VSWR: <ul style="list-style-type: none"> <li>◦ <math>\leq 1.10:1</math> at <math>\leq 250</math> MHz</li> <li>◦ <math>\leq 1.20:1</math> at <math>&gt;250</math> MHz, <math>\leq 301</math> MHz</li> </ul> </li> <li>• Impedance: 50 <math>\Omega</math></li> </ul>
SMA feed-thru terminator‡	Pasternack PE6026	<p>Test system characterization</p> <p>Adjustment</p> <p>Verifications:</p> <ul style="list-style-type: none"> <li>• Passband amplitude flatness and bandwidth</li> </ul>	<ul style="list-style-type: none"> <li>• Amplitude: 10 dBm</li> <li>• Frequency: 50 kHz to 301 MHz</li> <li>• VSWR: <math>\leq 1.25:1</math> at 301 MHz</li> <li>• Impedance: 50 <math>\Omega</math></li> </ul>



## Note

- \* The Aeroflex/Weinschel 1593 must be verified to VSWR  $\leq 1.10:1$  from

50 kHz to 495.1 MHz. This calibration procedure is written for the Keysight 11667A. If using the Aeroflex/Weinschel 1593, use the prescribed connectors and adapters in an analogous manner.

- † Required if using the Keysight 11667A.
- ‡ Required if using the Aeroflex/Weinschel 1593.

## Test Conditions

The following setup and environmental conditions are required to ensure the PXIe-5164 meets published specifications.

- Ensure that the PXI chassis fan speed is set to HIGH, that the fan filters are clean, and that the empty slots contain filler panels. For more information about cooling, refer to the ***Maintain Forced-Air Cooling Note to Users*** document available at [ni.com/docs](http://ni.com/docs).
- Plug the PXI chassis and the calibrator into the same power strip to avoid ground loops.
- Allow a warm-up time of at least 15 minutes after the chassis is powered on. The warm-up time ensures that the module is at a stable operating temperature.
- Allow a warm-up time for all of the instruments and equipment according to the manufacturer instructions.
- Maintain an ambient temperature of  $23\text{ °C} \pm 3\text{ °C}$ .
- Keep relative humidity between 10% and 90%, noncondensing.
- Keep cabling as short as possible. Long cables act as antennas, picking up extra noise that can affect measurements.
- Verify that all connections to the PXIe-5164, including front panel connections and screws, are secure.
- Use shielded copper wire for all cable connections to the device. Use twisted-pair wire to eliminate noise and thermal offsets.

## Device Setup

1. Install the PXIe-5164 in the PXI chassis according to the instructions in the PXIe-5164 Getting Started Guide, which is available at [ni.com/docs](http://ni.com/docs).
2. Configure the hardware using Measurement & Automation Explorer (MAX).

3. Launch the Calibration Executive procedure and complete the setup wizard.

## Test Limit Equations

The following test limits are derived from the published specifications.

**Table 200.** PXIe-5164 Test Limit Equations at 50  $\Omega$  Input Impedance

Equation Type	Equation
DC Accuracy	Accuracy = $\pm[(0.5\% \times  \text{Reading} ) + (0.2\% \text{ of FS})]$
AC Amplitude Accuracy	Accuracy = $\pm 0.2$ dB at 50 kHz
Amplitude Passband Flatness Bandwidth	Accuracy = -3 dB <ul style="list-style-type: none"> <li>Accuracy = <math>\pm 0.5</math> dB from 50 kHz to 330 MHz</li> </ul>
Timebase Accuracy	Accuracy = $\pm 5.0$ ppm
RMS Noise	if Vertical Range ( $V_{pk-pk}$ ) is 0.25 V = 0.045 % of FS if Vertical Range ( $V_{pk-pk}$ ) is 0.5 V = 0.040 % of FS if Vertical Range ( $V_{pk-pk}$ ) is 1 V = 0.035 % of FS if Vertical Range ( $V_{pk-pk}$ ) is 2.5 V = 0.030 % of FS if Vertical Range ( $V_{pk-pk}$ ) is 5 V = 0.030 % of FS

**Table 201.** PXIe-5164 Test Limit Equations at 1 M $\Omega$  Input Impedance

Equation Type	Equation
DC Accuracy	Accuracy = $\pm[(0.65\% \times  \text{Reading} - \text{Vertical Offset} ) + (0.4\% \times  \text{Vertical Offset} ) + (0.2\% \text{ of FS}) + 0.15 \text{ mV}]$
AC Amplitude Accuracy	Accuracy = $\pm 0.2$ dB at 50 kHz
Amplitude Passband Flatness Bandwidth	Accuracy = -3 dB

Equation Type	Equation
	<ul style="list-style-type: none"> <li>Accuracy = <math>\pm 0.7</math> dB from 50 kHz to 200 MHz</li> </ul>
Timebase Accuracy	Accuracy = $\pm 5.0$ ppm
RMS Noise	if Vertical Range ( $V_{pk-pk}$ ) is 0.25 V = 0.100 % of FS if Vertical Range ( $V_{pk-pk}$ ) is 0.5 V = 0.060 % of FS if Vertical Range ( $V_{pk-pk}$ ) is 1 V = 0.50 % of FS if Vertical Range ( $V_{pk-pk}$ ) is 2.5 V = 0.100 % of FS if Vertical Range ( $V_{pk-pk}$ ) is 5 V = 0.060 % of FS if Vertical Range ( $V_{pk-pk}$ ) is 10 V = 0.050 % of FS if Vertical Range ( $V_{pk-pk}$ ) is 25 V = 0.080 % of FS if Vertical Range ( $V_{pk-pk}$ ) is 50 V = 0.060 % of FS if Vertical Range ( $V_{pk-pk}$ ) is 100 V = 0.050 % of FS

### Related concepts:

- [Launching a Calibration Procedure](#)

## PXIe-5170R/5171R Calibration Procedure

Calibrate the PXIe-5170R/5171R modules using Calibration Executive.

### Calibration Executive Procedure Features

Verify Only ✓	Verify & Adjust ✓	Manual Mode ✓	Optional Adjust ☒
---------------	-------------------	---------------	-------------------

## Approximate Test Time

Device	Warmup	Verify Only	Verify & Adjust
PXIe-5170 (4 CH)	15 minutes	20 minutes	40 minutes
PXIe-5170 (8 CH)	15 minutes	30 minutes	55 minutes
PXIe-5171	15 minutes	30 minutes	60 minutes

## Test Equipment

The following table lists the test equipment required for calibrating PXIe-5170R/5171R modules.

**Table 312.** Test equipment for calibrating the PXIe-5170R/5171R

Instrument	Recommended Model	Specification	Requirements
Oscilloscope Calibrator	Fluke 9500B/600 with Fluke 9530 Active Head	Verifications: <ul style="list-style-type: none"> <li>• Timebase Accuracy</li> <li>• DC Accuracy</li> <li>• Input Impedance</li> <li>• Input Capacitance</li> </ul> Adjustments: <ul style="list-style-type: none"> <li>• Timebase Accuracy</li> <li>• DC Accuracy</li> </ul>	Sine Wave Amplitude Range: $0.9 V_{pk-pk}$ at 11 MHz into $50 \Omega$  Sine Wave Frequency Accuracy: 0.25 ppm at 11 MHz  DC Output Range: $\pm 40$ mV to $\pm 2.5$ V into $50 \Omega$  DC Output Accuracy: $\pm(0.025\%$ of output + $25 \mu V)$ into $50 \Omega$
SMA (m)-to- BNC (f) Adapter	Fairview Microwave SM4723	Verifications: <ul style="list-style-type: none"> <li>• Timebase Accuracy</li> <li>• DC Accuracy</li> </ul> Adjustments:	Frequency Range: DC to 11 MHz  Impedance: $50 \Omega$

Instrument	Recommended Model	Specification	Requirements
		<ul style="list-style-type: none"> <li>• Timebase</li> <li>• DC</li> </ul>	
DMM	PXI-4071	Verifications: <ul style="list-style-type: none"> <li>• AC Amplitude Accuracy</li> </ul>	AC voltage accuracy: $\pm 0.1\%$ of reading at 50 kHz AC Input Range: 0.1 V <sub>pk-pk</sub> to 3.5 V <sub>pk-pk</sub> AC Input Impedance: $\geq 10 \text{ M}\Omega$ Bandwidth: $\geq 100 \text{ kHz}$
Function Generator	PXI-5402 or Agilent 33250A	Verifications: <ul style="list-style-type: none"> <li>• AC Amplitude Accuracy</li> </ul>	Sine Wave Frequency: 50 kHz Sine Wave Amplitude Range: 0.1 V <sub>pk-pk</sub> to 3.5 V <sub>pk-pk</sub> into 50 $\Omega$
SMA Tee (f-f)	Fairview Microwave SM4942	Verifications: <ul style="list-style-type: none"> <li>• AC Amplitude Accuracy</li> </ul>	Impedance: 50 $\Omega$
SMA (m)-to-SMA (m) Adapter (x2)	Fairview Microwave SM4960	Test System Characterization Verifications: <ul style="list-style-type: none"> <li>• AC Amplitude Accuracy</li> <li>• Flatness and Bandwidth</li> </ul>	Frequency Range: DC to 275 MHz VSWR: $< 1.05$ Impedance: 50 $\Omega$
Double Banana Plug	Pasternack PE9008	Verifications:	Impedance: 50 $\Omega$

Instrument	Recommended Model	Specification	Requirements
to BNC (f)		<ul style="list-style-type: none"> <li>AC Amplitude Accuracy</li> </ul>	
SMA (m)-to-BNC (m) cable (x2)	—	Verifications: <ul style="list-style-type: none"> <li>AC Amplitude Accuracy</li> </ul>	Frequency Range: DC to 275 $\Omega$ Impedance: 50 $\Omega$ Length: < 1 meter
Power Sensor	Rohde & Schwarz NRP-Z91 with NRP-Z4 USB adapter	Test System Characterization Verifications: <ul style="list-style-type: none"> <li>Flatness and Bandwidth</li> </ul>	Range: -15 dBm to 5 dBm Frequency range: 50 kHz to 275 MHz Absolute power accuracy: <0.048 dB for < 100 MHz, <0.063 dB for 100 MHz to 275 MHz Relative power accuracy: <0.022 dB for 100 MHz, <0.031 dB for 100 MHz to 275 MHz VSWR: < 1.11
Signal Generator	Rohde & Schwarz SMA100A base unit with required frequency option SMA-B103	Test System Characterization Verifications: <ul style="list-style-type: none"> <li>Flatness and Bandwidth</li> </ul>	Frequency range: 50 kHz to 275 MHz Amplitude range: -7 dBm to 8 dBm Harmonics: <-30 dBc
Power Splitter	Aeroflex/Weinschel 1593	Test System Characterization Verifications:	Frequency range: 50 kHz to 275 MHz VSWR: <1.08



Instrument	Recommended Model	Specification	Requirements
		<ul style="list-style-type: none"> <li>Flatness and Bandwidth</li> </ul>	Amplitude tracking: <0.5 dB
50 $\Omega$ SMA Terminator (f)	Fairview Microwave ST1825F	Test System Characterization	Frequency Range: DC to 275 MHz VSWR: <1.05 Impedance: 50 $\Omega$
SMA (f)-to-N (m) Adapter	Fairview Microwave SM4226	Test System Characterization  Verifications: <ul style="list-style-type: none"> <li>Flatness and Bandwidth</li> </ul>	Frequency Range: DC to 275 MHz  VSWR: <1.05  Impedance: 50 $\Omega$
SMA (f)-to-N (f) Adapter	Fairview Microwave SM4236	Test System Characterization  Verifications: <ul style="list-style-type: none"> <li>Flatness and Bandwidth</li> </ul>	Frequency Range: DC to 275 MHz  VSWR: <1.05  Impedance: 50 $\Omega$

## Test Conditions

The following setup and environmental conditions are required to ensure the PXIe-5170R/5171R devices meet published specifications.

- Keep connections to the device as short as possible. Long cables and wires act as antennas, picking up noise that can affect measurements.
- Verify that all connections to the device, including front panel connections, are secure.

- Use shielded copper wire for all cable connections to the device. Use twisted-pairs wire to eliminate noise and thermal offsets.
- Maintain an ambient temperature of  $23 \pm 3$  °C. The device temperature will be greater than the ambient temperature.
- Keep relative humidity between 10% and 90% noncondensing.
- Allow a warm up time of at least 15 minutes to ensure that the measurement circuitry is at a stable operating temperature.
- Ensure that the PXI Express chassis fan speed is set to HIGH, the fan filters are removed, and the empty slots contain PXI chassis slot blockers and filler panels. For more information, refer to the Maintain Forced-Air Cooling Note to Users document available at [ni.com/docs](http://ni.com/docs).
- Plug the chassis/PC and the test equipment into the same power strip to avoid ground loops.

## Device Setup

1. Install the module in the PXI chassis or PC according to the instructions in the NI PXIe-5170R/5171R Getting Started Guide.
2. Configure the hardware using Measurement & Automation Explorer (MAX).
3. Launch the Calibration Executive procedure and complete the setup wizard.

## Test Limit Equations

The following test limits are derived from published specifications.

**Table 203.** PXIe-5170R/5171R Test Limit Equations

Equation Type	Equation
DC Accuracy	Accuracy = $\pm(\% \text{ of }  \text{Reading}  + \% \text{ of FS} + \text{mV})$
AC Amplitude Accuracy	Accuracy = $\pm 0.15$ dB at 50 kHz
Bandwidth	Accuracy = -3 dB
Timebase Accuracy	Accuracy = $\pm 25.0$ ppm

## PXIe-5172 Calibration Procedure

Calibrate the PXIe-5172 4-channel and 8-channel modules using Calibration Executive.

## Calibration Executive Procedure Features

Verify Only ✓	Adjust Only ✓	Verify & Adjust ✓	Manual Mode ✓	Optional Adjust ✓
---------------	---------------	-------------------	---------------	-------------------

## Approximate Test Time

Device	Verify Only	Adjust Only	Verify & Adjust
4-channel	29 minutes	14 minutes	62 minutes
8-channel	40 minutes	22 minutes	92 minutes

## Test Equipment

The following table lists the test instruments required for calibrating the PXIe-5172.

**Table 312.** Test equipment for calibrating the PXIe-5172

Instrument	Recommended Model	Where Used	Minimum Requirements
Oscilloscope calibrator	Fluke 9500B/600 with Fluke 9530 Active Head	Verifications: <ul style="list-style-type: none"> <li>• Timebase accuracy</li> <li>• DC accuracy</li> </ul> Adjustment	Sine wave generation: <ul style="list-style-type: none"> <li>• Amplitude: 1.25 V<sub>pk-pk</sub> into 50 Ω</li> <li>• Frequency: 11 MHz and 89 MHz</li> <li>• Frequency accuracy: ±0.25 ppm</li> </ul>
			Square wave generation: <ul style="list-style-type: none"> <li>• Amplitude: 0.7 V<sub>pk-pk</sub> to 20 V<sub>pk-pk</sub> into 1 MΩ symmetrical to ground (0 V)</li> <li>• Frequency: 500 Hz</li> <li>• Abberations: &lt;2% of peak for the first 500 ns</li> </ul>
			DC generation:

Instrument	Recommended Model	Where Used	Minimum Requirements
			<ul style="list-style-type: none"> <li>• Amplitude: <math>\pm 5</math> V into <math>50 \Omega</math>, <math>\pm 40</math> V into <math>1 \text{ M}\Omega</math></li> <li>• Accuracy: <math>\pm(0.025\%</math> of output + <math>25 \mu\text{V}</math>)</li> </ul>
DMM	PXI-4071	Verifications: <ul style="list-style-type: none"> <li>• AC amplitude accuracy</li> </ul>	AC voltage measurement: <ul style="list-style-type: none"> <li>• Range: <math>0.1 \text{ V}_{\text{pk-pk}}</math> to <math>20 \text{ V}_{\text{pk-pk}}</math></li> <li>• Input impedance: <math>\geq 10 \text{ M}\Omega</math></li> <li>• Bandwidth: <math>\geq 50 \text{ kHz}</math></li> <li>• Accuracy at <math>50 \text{ kHz}</math>:                             <ul style="list-style-type: none"> <li>◦ <math>\pm(0.07\%</math> of reading + <math>14 \mu\text{V}</math>) for <math>0.1 \text{ V}_{\text{pk-pk}}</math> test point</li> <li>◦ <math>\pm(0.06\%</math> of reading + <math>71 \mu\text{V}</math>) for <math>0.7 \text{ V}_{\text{pk-pk}}</math> to <math>1.4 \text{ V}_{\text{pk-pk}}</math> test points</li> <li>◦ <math>\pm(0.06\%</math> of reading + <math>707 \mu\text{V}</math>) for <math>2.5 \text{ V}_{\text{pk-pk}}</math> to <math>5.0 \text{ V}_{\text{pk-pk}}</math> test points</li> <li>◦ <math>\pm(0.12\%</math> of reading + <math>35 \text{ mV}</math>) for <math>20.0 \text{ V}_{\text{pk-pk}}</math> test point</li> </ul> </li> </ul>
Function generator	PXI-5402/5406 or Keysight 33220A	Verifications: <ul style="list-style-type: none"> <li>• AC amplitude accuracy</li> </ul>	Sine wave generation: <ul style="list-style-type: none"> <li>• Amplitude:                             <ul style="list-style-type: none"> <li>◦ <math>0.1 \text{ V}_{\text{pk-pk}}</math> to <math>5.0 \text{ V}_{\text{pk-pk}}</math> into <math>50 \Omega</math></li> <li>◦ <math>0.1 \text{ V}_{\text{pk-pk}}</math> to <math>20 \text{ V}_{\text{pk-pk}}</math> into <math>1 \text{ M}\Omega</math></li> </ul> </li> <li>• Frequency: <math>50 \text{ kHz}</math></li> </ul>
SMB (plug) to BNC (f) adapter	Fairview Microwave SM3633	Verifications: <ul style="list-style-type: none"> <li>• Timebase</li> </ul>	<ul style="list-style-type: none"> <li>• Frequency: DC to <math>89 \text{ MHz}</math></li> <li>• Impedance: <math>50 \Omega</math></li> </ul>

Instrument	Recommended Model	Where Used	Minimum Requirements
		accuracy • DC accuracy  Adjustment	
SMA Tee (f-f)	Fairview Microwave SM4942	Verifications:  • AC amplitude accuracy	Impedance: 50 Ω
Double banana plug to BNC (f)	Pasternack PE9008	Verifications:  • AC amplitude accuracy	Impedance: 50 Ω
BNC (m)-to-SMA (m) cable (x2)	Fairview Microwave FMC0208315-36	Verifications:  • AC amplitude accuracy	• Length: ≤1 meter • Impedance: 50 Ω
Power sensor	Rohde & Schwarz NRP-Z91	Test system characterization  Verifications:  • Bandwidth	Power measurement:  • Frequency range: 50 kHz to 101 MHz • Power range: -16 dBm to 10 dBm • VSWR: <1.11 • Absolute accuracy: ◦ <0.048 dB for 50 kHz to <100 MHz ◦ <0.063 dB for 100.1 MHz • Relative accuracy at -4 dBm: <0.022 dB for 50 kHz to <101 MHz

Instrument	Recommended Model	Where Used	Minimum Requirements
Signal generator	Rohde & Schwarz SMA100A base unit with required frequency option SMA-B103	Test system characterization Verifications: <ul style="list-style-type: none"> <li>Bandwidth</li> </ul>	Sine wave generation: <ul style="list-style-type: none"> <li>Amplitude: -10 dBm to 16 dBm</li> <li>Frequency: 50 kHz to 101 MHz</li> <li>Harmonics: &lt;-30 dBc</li> </ul>
Power splitter	Aeroflex/Weinschel 1593	Test system characterization Verifications: <ul style="list-style-type: none"> <li>Bandwidth</li> </ul>	<ul style="list-style-type: none"> <li>Amplitude: -16 dBm to 16 dBm</li> <li>Frequency: 50 kHz to 101 MHz</li> <li>VSWR: &lt;1.09</li> </ul>
50 $\Omega$ SMA terminator (m)	Fairview Microwave ST1819	Test system characterization	<ul style="list-style-type: none"> <li>Amplitude: 10 dBm</li> <li>Frequency: DC to 101 MHz</li> <li>VSWR: &lt;1.1</li> </ul>
50 $\Omega$ SMB terminator (plug)	Fairview Microwave ST04B-P	Verifications: <ul style="list-style-type: none"> <li>RMS noise</li> </ul>	<ul style="list-style-type: none"> <li>Frequency: DC to 200 MHz</li> <li>VSWR: &lt;1.2</li> </ul>
SMA (m)-to-SMA (m) cable	Fairview Microwave FMC0202317-36	Test system characterization Verifications: <ul style="list-style-type: none"> <li>Bandwidth</li> </ul>	<ul style="list-style-type: none"> <li>Frequency: DC to 101 MHz</li> <li>VSWR: &lt;1.1</li> <li>Length: <math>\leq</math>1 meter</li> <li>Impedance: 50 <math>\Omega</math></li> </ul>
SMA (f)-to-N (m) adapter	Fairview Microwave SM4226	Test system characterization Verifications: <ul style="list-style-type: none"> <li>Bandwidth</li> </ul>	<ul style="list-style-type: none"> <li>Frequency: DC to 101 MHz</li> <li>VSWR: &lt;1.05</li> <li>Impedance: 50 <math>\Omega</math></li> </ul>

Instrument	Recommended Model	Where Used	Minimum Requirements
SMA (m)-to-N (f) adapter	Fairview Microwave SM4268	Test system characterization Verifications: <ul style="list-style-type: none"> <li>Bandwidth</li> </ul>	<ul style="list-style-type: none"> <li>Frequency: DC to 101 MHz</li> <li>VSWR: &lt;1.1</li> <li>Impedance: 50 <math>\Omega</math></li> </ul>
SMA (m)-to-SMB (plug) adapter*	Fairview Microwave SM2069	Verifications: <ul style="list-style-type: none"> <li>Bandwidth</li> <li>AC amplitude accuracy</li> </ul>	<ul style="list-style-type: none"> <li>Frequency: DC to 101 MHz</li> <li>VSWR: &lt;1.1</li> <li>Impedance: 50 <math>\Omega</math></li> </ul>
SMA feed-thru terminator	Pasternack PE6026	Verifications: <ul style="list-style-type: none"> <li>Bandwidth</li> </ul>	<ul style="list-style-type: none"> <li>Amplitude: 10 dBm</li> <li>Frequency: 50 kHz to 100 MHz</li> <li>VSWR: &lt;1.1 at 100 MHz</li> <li>Impedance: 50 <math>\Omega</math></li> </ul>



**Note** \*NI recommends using three SMA (m)-to-SMB (plug) adapters to reduce the test time. Always check the state of the SMB connector. Do not use adapters with defective or broken plates, because they might damage the DUT. Steps that require the SMA (m)-to-SMB (plug) adapters are AC Accuracy Verification, 50  $\Omega$  Bandwidth, and 1 M $\Omega$  Bandwidth.

## Test Conditions

The following setup and environmental conditions are required to ensure the PXIe-5172 meets published specifications.

- Ensure that the PXI chassis fan speed is set to HIGH, that the fan filters are clean, and that the empty slots contain filler panels. For more information about cooling, refer to the ***Maintain Forced-Air Cooling Note to Users*** document available at [ni.com/docs](http://ni.com/docs).

- Plug the PXI chassis and the instrument standard into the same power strip to avoid ground loops.
- Allow a warm-up time of at least 15 minutes after the chassis is powered on. The warm-up time ensures that the module is at a stable operating temperature.
- Allow a warm-up time for all of the instruments and equipment according to the manufacturer instructions.
- Maintain an ambient temperature of  $23\text{ }^{\circ}\text{C} \pm 3\text{ }^{\circ}\text{C}$ .
- Keep relative humidity between 10% and 90%, noncondensing.
- Keep cabling as short as possible. Long cables act as antennas, picking up extra noise that can affect measurements.
- Verify that all connections to the PXIe-5172, including front panel connections and screws, are secure.
- Use shielded copper wire for all cable connections to the device. Use twisted-pair wire to eliminate noise and thermal offsets.

## Device Setup

1. Install the PXIe-5172 in the PXI chassis according to the instructions in the PXIe-5172 Getting Started Guide, which is available at [ni.com/docs](http://ni.com/docs).
2. Configure the hardware using Measurement & Automation Explorer (MAX).
3. Launch the Calibration Executive procedure and complete the setup wizard.

## Test Limit Equations

The following test limits are derived from the published specifications.

**Table 205.** PXIe-5172 Test Limit Equations

Equation Type	Equation
DC Accuracy for 50 $\Omega$ input impedance	Accuracy = $\pm[(0.45\% \times  \text{Reading} - \text{Vertical Offset} ) + (0.4\% \times  \text{Vertical Offset} ) + (0.05\% \times \text{Full Scale}) + 0.4\text{ mV}]$
DC Accuracy for 1 M $\Omega$ input impedance	40 V <sub>pp</sub> range: Accuracy = $\pm[(0.45\% \times  \text{Reading} - \text{Vertical Offset} ) + (0.5\% \times  \text{Vertical Offset} ) + (0.05\% \times \text{Full Scale}) + 0.4\text{ mV}]$  All other ranges: Accuracy = $\pm[(0.45\% \times  \text{Reading} -$



Equation Type	Equation
	Vertical Offset) + (0.4% x  Vertical Offset ) + (0.05% x Full Scale) + 0.4 mV]
AC Accuracy	1 M $\Omega$ input impedance at ranges 40 V <sub>pp</sub> and 80 V <sub>pp</sub> : $\pm 0.25$ dB at 50 kHz  50 $\Omega$ input impedance and all the other ranges at 1 M $\Omega$ input impedance: $\pm 0.15$ dB at 50 kHz
Bandwidth Accuracy	50 $\Omega$ and 1 M $\Omega$ input impedance: -3 dB to 1 dB
Timebase Accuracy	$\pm 2225$ Hz

### Related concepts:

- [Launching a Calibration Procedure](#)

## PXIe-5185/5186 Calibration Procedure

Calibrate the PXIe-5185/5186 modules using Calibration Executive.

### Calibration Executive Procedure Features

Verify Only ✓	Adjust Only ✓	Verify & Adjust ✓	Manual Mode ✓	Optional Adjust ✗
---------------	---------------	-------------------	---------------	-------------------

### Approximate Test Time

Device	Verify Only	Adjust Only	Verify & Adjust
50 $\Omega$ Devices	15 minutes	14 minutes	31 minutes
1 M $\Omega$ Devices	27 minutes	23 minutes	63 minutes

### 50 $\Omega$ and 1 M $\Omega$ Modules

Early versions of the PXIe-5185/5186 support only 50  $\Omega$  input impedance. Check the

part number of your module to confirm the supported input impedance:

- PXIe-5185 and -5186 modules with part numbers that begin with 19... support only 50  $\Omega$  input impedance.
- PXIe-5185 and -5186 modules with part numbers that begin with 15... support 50  $\Omega$  and 1 M $\Omega$  input impedance.

## Test Equipment

The following table lists the test equipment required for calibrating the PXIe-5185/5186 1 M $\Omega$  module.

**Table 312.** Test equipment for calibrating the PXIe-5185/5186 1 M $\Omega$

Required Equipment	Recommended Equipment	Minimum Requirements
Oscilloscope calibrator	Fluke 9500B/3200	DC Output Range: 2 V to -2 V into 50 $\Omega$ , 6.5 V to -6.5 V into 1 M $\Omega$
3.2 GHz output module	Fluke 9530 Active Head	DC Voltage Accuracy: DC $\pm 0.3\%$ of output into 50 $\Omega$ and 1 M $\Omega$  Leveled Sine Wave Amplitude Range: 0.9 V <sub>pk-pk</sub> into 50 $\Omega$  Leveled Sine Wave Amplitude Accuracy: $\pm 1.5\%$ at 50 kHz, $\pm 6.5\%$ from 1 GHz to 5 GHz into 50 $\Omega$ and VSWR $\leq 1.6:1$  Leveled Sine Wave Frequency Accuracy: $\pm 4$ ppm  Square Wave: 8.0 V <sub>pk-pk</sub> at 100 kHz into 1 M $\Omega$
Power sensor	Rohde & Schwarz NRP-Z91	Range: -26 dBm to 10 dBm  Frequency range: 50 kHz to 5.0 GHz  Absolute power accuracy: <0.048 dB at 50 kHz <0.063 dB at 5.0 GHz

Required Equipment	Recommended Equipment	Minimum Requirements
		<p>Relative power accuracy: &lt;0.022 dB at 50 kHz &lt;0.031 dB for frequencies &gt;50 kHz and &lt;5.0 GHz</p> <p>VSWR: &lt;1.11</p>
Signal generator	Rohde & Schwarz SMA100A base unit with required frequency option: (PXIe-5185) SMA-B103 (PXIe-5186) SMA-B106	<p>Frequency range: 50 kHz to 5.0 GHz</p> <p>Amplitude range: -20 dBm to 16 dBm</p> <p>Harmonics: &lt;-30 dBc</p>
Power splitter	Aeroflex/Weinschel	<p>Frequency range: 50 kHz to 5.0 GHz</p> <p>VSWR: &lt;1.1</p> <p>Amplitude tracking &lt;0.5 dB</p>
50 $\Omega$ BNC terminator (f)	Fairview Microwave ST3B-F	<p>Frequency range: DC to 0.5 GHz</p> <p>VSWR: &lt;1.2</p> <p>Impedance: 50 <math>\Omega</math></p>
50 $\Omega$ SMA terminator (f)	Fairview Microwave ST1852F	<p>Frequency range: DC to 5.0 GHz</p> <p>VSWR: &lt;1.1</p> <p>Impedance: 50 <math>\Omega</math></p>
SMA (m)-to-SMA (m) cable	—	<p>Frequency range: DC to 5.0 GHz</p> <p>VSWR: &lt;1.1</p> <p>Length: <math>\leq</math>1 m</p>
SMA (f)-to-N (m) adapter	Fairview Microwave SM4226	Frequency range: DC to 5.0 GHz

Required Equipment	Recommended Equipment	Minimum Requirements
		VSWR: <1.05 Impedance: 50 $\Omega$
SMA (f)-to-N (f) adapter	Fairview Microwave SM4236	Frequency range: DC to 5.0 GHz VSWR: <1.15 Impedance: 50 $\Omega$
SMA (m)-to-SMA (m) adapter (x2)	Fairview Microwave SM4960	Frequency range: DC to 5.0 GHz VSWR: <1.1 Impedance: 50 $\Omega$
BNC (f)-to-N (f) adapter	Fairview Microwave SM3526	Frequency range: DC to 0.5 GHz VSWR: <1.2 Impedance: 50 $\Omega$
SMA (m)-to-BNC (m) adapter (x2)	Fairview Microwave SM4716	Frequency range: DC to 0.5 GHz Impedance: 50 $\Omega$
SMA (m)-to-BNC (f) adapter	Fairview Microwave SM4723	Frequency range: DC to 100 kHz Impedance: 50 $\Omega$
BNC feed-through terminator	Fairview Microwave ST0150	Frequency range: DC to 0.5 GHz VSWR: <1.1 at 100 MHz <1.25 at 500 MHz Impedance: 50 $\Omega$
PXI Express Chassis	Any NI PXI Express chassis that meets the requirements.	100 MHz reference clock for PXI Express slots with an accuracy of $\pm 25$ ppm.



**Note** NI recommends using two power splitters to reduce test time. One should be used for the 50  $\Omega$  characterization and AC accuracy and bandwidth steps, the other for the 1 M $\Omega$  characterization and AC accuracy and bandwidth steps.

## Test Conditions

The following setup and environmental conditions are required to ensure the PXIe-5185/5186 meets published specifications.

- Keep connections to the device as short as possible. Long cables and wires act as antennas, picking up extra noise that can affect measurements.
- Verify that all connections to the device, including front panel connections, are secure.
- Use shielded copper wire for all cable connections to the device. Use twisted-pairs wire to eliminate noise and thermal offsets.
- Maintain an ambient temperature of  $23 \pm 3^\circ\text{C}$ . The device temperature will be greater than the ambient temperature.
- Keep relative humidity below 80%.
- Allow a warm up time of at least 25 minutes to ensure that the measurement circuitry is at a stable operating temperature.
- Ensure that the PXI Express chassis fan speed is set to HIGH, that the fan filters are clean if present, and that the empty slots contain PXI chassis slot blockers and filler panels. For more information, refer to the Maintain Forced-Air Cooling Note to Users document available at [ni.com/docs](http://ni.com/docs).
- Plug the chassis and the calibrator into the same power strip to avoid ground loops.

## Device Setup

1. Install the PXIe-5185/5186 in the PXI Express chassis according to the instructions in the NI High-Speed Digitizers Getting Started Guide.
2. Configure the hardware using Measurement & Automation Explorer (MAX).
3. Launch the Calibration Executive procedure and complete the setup wizard.



**Note** If the PXIe-5185/5186 module fails after calibration, return it to NI for

repair or replacement.

## Test Limit Equations

The following test limits are derived from the published specifications.

**Table 207.** PXIe-5185/5186 Test Limit Equations

Equation Type	Equation
DC Accuracy	$\text{TestLimits} = \text{TestValue} \pm \text{Accuracy}$ <p>Accuracy for the 50 <math>\Omega</math> input = <math>\pm[\text{abs}(2\% \text{ of TestPoint}) + 0.35\% \text{ FullScale} + 0.7 \text{ mV}] + 1.2\% \text{ of Offset Setting}</math></p> <p>Accuracy for the 1 <math>\Omega</math> input = <math>\pm[\text{abs}(2\% \text{ of TestPoint}) + 0.9\% \text{ FullScale} + 1.3 \text{ mV}] + 1.2\% \text{ of Offset Setting}</math></p>
Timebase Frequency	$\text{TestLimits} = \pm 25 \text{ ppm}$

### Related concepts:

- [Launching a Calibration Procedure](#)

## PXIe-5622 Calibration Procedure

Calibrate the PXIe-5622 using Calibration Executive.

### Calibration Executive Procedure Features

Verify Only ✓	Verify & Adjust ✓	Manual Mode ✓	Optional Adjust ✗
---------------	-------------------	---------------	-------------------

### Approximate Test Time

40 minutes

## Test Equipment

The following table lists the test instruments required for calibrating the PXIe-5622.

**Table 312.** Test equipment for calibrating the PXIe-5622

Instrument	Recommended Model	Parameter Measured	Minimum Requirements
Signal Generator	Rohde & Schwarz SMA-100A base unit with required frequency option SMA-B103 and with option SMA-B22 for enhanced phase noise performance	SSB Phase Noise	Carrier offset at 53 MHz carrier frequency: <ul style="list-style-type: none"> <li>• 100: -108 dBc/Hz</li> <li>• 10 k: -146 dBc/Hz</li> <li>• 100 k: -158 dBc/Hz</li> </ul> Carrier offset at 187 MHz carrier frequency: <ul style="list-style-type: none"> <li>• 100: -98 dBc/Hz</li> <li>• 10 k: -135 dBc/Hz</li> <li>• 100 k: -148 dBc/Hz</li> </ul>
		Bandpass Amplitude Flatness, Absolute Amplitude Accuracy, SSB Phase Noise, Timing	Frequency Range: 900 kHz to 820 MHz Power Measurement Level Setting Range: -4 dBm to 10 dBm

Instrument	Recommended Model	Parameter Measured	Minimum Requirements
		Accuracy, Adjustment	
		Timing Accuracy, Adjustment	±0.1 ppm frequency accuracy
Power Meter	Rohde & Schwarz NRPZ-91 with NRP-Z4 USB adapter	Absolute Amplitude Accuracy, Bandpass Amplitude Flatness, Adjustment	Frequency Range: 900 kHz to 820 MHz  Power Measurement Range: -4 dBm to 3 dBm  Maximum VSWR: 1.11 (23 °C ±5 °C)  Absolute Power Measurement Uncertainty: 0.081 dB (23 °C ±5 °C)  Relative Power Measurement Uncertainty: 0.05 dB (23 °C ±5 °C)
SMA Cable	Mini-Circuits CBL-1.5FT-SMSM+	Bandpass Amplitude Flatness, Absolute Amplitude Accuracy,	50 Ω Max VSWR: 1.20  Frequency Range: 900 kHz to 820 MHz  Power Measurement Range: -4 to 3 dBm  Relative Shielding:



Instrument	Recommended Model	Parameter Measured	Minimum Requirements
		SSB Phase Noise, Timing Accuracy, Adjustment	-100 dB
Attenuator	Mini-Circuits VAT-3+	SSB Phase Noise	Frequency Range: 900 kHz to 820 MHz  Minimum Power (W): 10 mW  Maximum VSWR: 1.20  Nominal Attenuation: 3 dB
SMA Termination	Mini-Circuits ANNE-50+	Average Noise Density	50 $\Omega$
Power Splitter	Weinschel WA1507R	Absolute Amplitude Accuracy, Bandpass Amplitude Flatness, Adjustment	Frequency Range: 900 kHz to 820 MHz  Input Power Range: -4 dBm to 3 dBm  Maximum VSWR (Output Ports): 1.15  Maximum Amplitude Tracking: 0.15 dBm

## Test Conditions

The following setup and environmental conditions are required to ensure the PXIe-5622 meets published specifications.

- Keep cables as short as possible. Long cables act as antennas, picking up noise that can affect measurements.
- Verify that all connections, including front panel connections, are secure.
- Ensure that the PXI Express chassis fan speed is set to HIGH, that the fan filters are clean, and that the empty slots contain filler panels. For more information, refer to the ***Maintain Forced-Air Cooling Note to Users***, available at [ni.com/docs](http://ni.com/docs).
- Keep relative humidity between 10% and 90% non-condensing, or consult the digitizer hardware specifications for the optimum relative humidity.
- Maintain an ambient temperature of  $23\text{ }^{\circ}\text{C} \pm 5\text{ }^{\circ}\text{C}$ .
- Allow a warm-up time of at least 15 minutes after the NI-SCOPE driver is loaded. Unless manually disabled, NI-SCOPE automatically loads with the operating system and enables the device. The warm-up time ensures that the measurement circuitry of the digitizer is at a stable operating temperature.
- Plug the PXI Express chassis and the test equipment into the same power strip to avoid ground loops.

## Device Setup

1. Install the PXIe-5622 in a PXI Express chassis according to the instructions in the ***NI High-Speed Digitizers Getting Started Guide***.
2. Configure the hardware using Measurement & Automation Explorer (MAX).
3. Launch the Calibration Executive procedure.

### Related concepts:

- [Launching a Calibration Procedure](#)

## PXIe-5624 Calibration Procedure

Calibrate the PXIe-5624 using Calibration Executive.

The PXIe-5624 IF Digitizer, PXIe-5606 RF Signal Downconverter, and PXIe-5653 RF

Synthesizer are components of the PXIe-5668 Vector Signal Analyzer.

## Calibration Executive Procedure Features

Verify Only ✓	Adjust Only ✓	Verify & Adjust ✓	Manual Mode ✗	Optional Adjust ✗
---------------	---------------	-------------------	---------------	-------------------

## Approximate Test Time

Verify Only	Adjust Only	Verify & Adjust
40 minutes	30 minutes	60 minutes

## Test Equipment

The following table lists the test instruments required for calibrating the PXIe-5624. Refer also to test equipment tables for PXIe-5606, PXIe-5653, and PXIe-5668.

**Table 209.** Test equipment for calibrating the PXIe-5624

Instrument	Recommended Model	Where Used	Requirements
Power sensor	Rohde & Schwarz NRP-Z91	Test system characterization  Verifying absolute amplitude accuracy  Adjusting absolute amplitude accuracy	Range: -15 dBm to +10 dBm  Frequency range: 4 MHz to 2.005 GHz  Power linearity: <0.1 dB  VSWR: <1.11 at 2.005 GHz
Signal generator	Rohde & Schwarz SMA100A base unit with options B103 and B22	Test system characterization  Verifying internal frequency reference  Verifying absolute amplitude	Frequency range: 4 MHz to 2.005 GHz  Amplitude range: -10 dBm to 10 dBm  Frequency accuracy: $\leq \pm 3.5 \times 10^{-8}$

Instrument	Recommended Model	Where Used	Requirements
		accuracy  Adjusting internal frequency reference  Adjusting absolute amplitude accuracy	
Power splitter	Aeroflex/Weinschel 1593	Test system characterization  Verifying absolute amplitude accuracy  Adjusting absolute amplitude accuracy	VSWR: <1.25 at 4 MHz to 2 GHz  Amplitude tracking: <0.25 dB  Maximum Input Power: >10 dBm CW
6 dB attenuator	Anritsu 41KB-6 or Mini-Circuits BW-S6W2	Test system characterization  Verifying absolute amplitude accuracy  Adjusting absolute amplitude accuracy	Frequency range: DC to 2 GHz VSWR: <1.2
50 $\Omega$ SMA terminator (m)	—	Test system characterization	Frequency range: DC to 2 GHz VSWR: <1.1
SMA (m)-to-SMA (m) cable (x2)	—	All procedures	Frequency range: DC to 2 GHz  Impedance: 50 $\Omega$

Instrument	Recommended Model	Where Used	Requirements
			Maximum length: 1 meter
SMA (f)-to-N (m) adapter	Fairview Microwave SM4226	All procedures	Frequency range: DC to 2 GHz Impedance: 50 Ω Return loss: ≥23 dB
SMA (m)-to-N (f) adapter	Huber+Suhner 33_SMA_N-50-1/1-UE or Fairview Microwave SM4241	Test system characterization  Verifying absolute amplitude accuracy  Adjusting absolute amplitude accuracy	Frequency range: DC to 2 GHz  Impedance: 50 Ω  Return loss: ≥23 dB
SMA (f)-to-N (f) adapter	Huber+Suhner 31_3-SMA-50-1/1-UE or Fairview Microwave SM4236	Test system characterization	Frequency range: DC to 2 GHz  Impedance: 50 Ω  Return loss: ≥23 dB
3.5 mm (m)-to-3.5 mm (m) adapter	Huber+Suhner 32_PC35-50-0-2/199_NE or Fairview Microwave SM4960	Test system characterization  Verifying absolute amplitude accuracy  Adjusting absolute amplitude accuracy	Frequency range: DC to 2 GHz  Impedance: 50 Ω  Return loss: ≥30 dB

Instrument	Recommended Model	Where Used	Requirements
3.5 mm (f)-to-3.5 mm (f) adapter	Huber+Suhner 31_PC35-50-0-1/199_UE	Test system characterization	Frequency range: DC to 2 GHz Impedance: 50 $\Omega$ Return loss: $\geq 28$ dB
Frequency reference source*	Symmetricon 8040C rubidium frequency standard	All test steps	Frequency: 10 MHz Frequency Accuracy: $\leq 1 \times 10^{-9}$



**Note** \* A frequency reference source is recommended if the PXIe-5624 module is part of a PXIe-5668 vector signal analyzer. Otherwise this instrument is not needed, and you can select "unsupported instrument" in the Calibration Executive Setup Wizard with the details of the signal generator.

## Test Conditions

The following setup and environmental conditions are required to ensure the PXIe-5624 meets published specifications.

- Keep cabling as short as possible. Long cables and wires act as antennas, picking up extra noise that can affect measurements.
- Verify that all connections, including front panel connections and screws, are secure. Maintain an ambient temperature of  $23\text{ }^{\circ}\text{C} \pm 5\text{ }^{\circ}\text{C}$ .
- Keep the relative humidity between 10% and 90%, noncondensing.
- Ensure that the PXI/PXI Express chassis fan speed is set to HIGH and that the empty slots contain filler panels. For more information about maintaining adequate air circulation in your PXI/PXI Express chassis, refer to the ***Maintain Forced-Air Cooling Note to Users*** document available at [ni.com/docs](http://ni.com/docs).
- Allow a warm-up time of at least 20 minutes after the chassis is powered on, the NI LabVIEW Instrument Design Libraries for IF Digitizers software is loaded by the host, and the host recognizes the NI 5624R. The warm-up time ensures that the NI 5624R and test instrumentation are at a stable operating temperature.
- Perform self-calibration on the NI 5624R.

- Plug the PXI Express chassis and the test equipment into the same power strip to avoid ground loops.
- Use a torque wrench appropriate for the type of RF connector that you are using. NI recommends a 0.565 N · m (5 lb · in.) wrench for SMA connectors and an 0.90 N · m (8 lb · in.) wrench for 2.9 mm connectors.
- In each verification procedure, insert a delay between configuring all devices and acquiring the measurement. Adjust this delay depending on the instruments used but make sure it is at least 5,000 ms for the first iteration and 10 ms for each other iteration.

## Device Setup

Refer to the ***NI PXIe-5624R Getting Started Guide*** for information about how to install the software and hardware and how to configure the device in Measurement & Automation Explorer (MAX).

1. Install the NI 5624R in the PXI Express chassis according to the instructions in the NI RF Signal Generators Getting Started Guide and the PXIe-5668 Getting Started Guide.
2. Configure the hardware using Measurement & Automation Explorer (MAX). You must create a MAX association between the hardware modules to control them as a single RF device before you can program the device. Complete the following steps to make this association.
  - a. In MAX, select the NI 5606 RF downconverter in the configuration tree.
  - b. In the Associated Devices section, select the appropriate module from each system component drop-down listbox.

For NI 5668R, you must associate the NI 5624R IF digitizer module and the NI 5653 LO source module with the NI 5606 RF downconverter.



**Note** Device associations are lost when you move modules to different chassis slots.

- c. Click **Save** in the MAX toolbar.
3. Launch the Calibration Executive procedure. Calibration Executive guides you through the required connections.

## Connection Diagram

The following figure illustrates the connections necessary for characterizing the power splitter reference output. In the figure, components 2, 7, 6 and 5 create a splitter filter fixture with attenuator. Do not alter connections inside this assembly during procedure execution.



**Note** Once the power sensor (9) is connected to the SMA (f)-to-N (m) adaptor (8), it is recommended to keep them connected. This improves test time and decreases wear on the connectors.

**Figure 4.** Connection Diagram for Measuring at Splitter Output

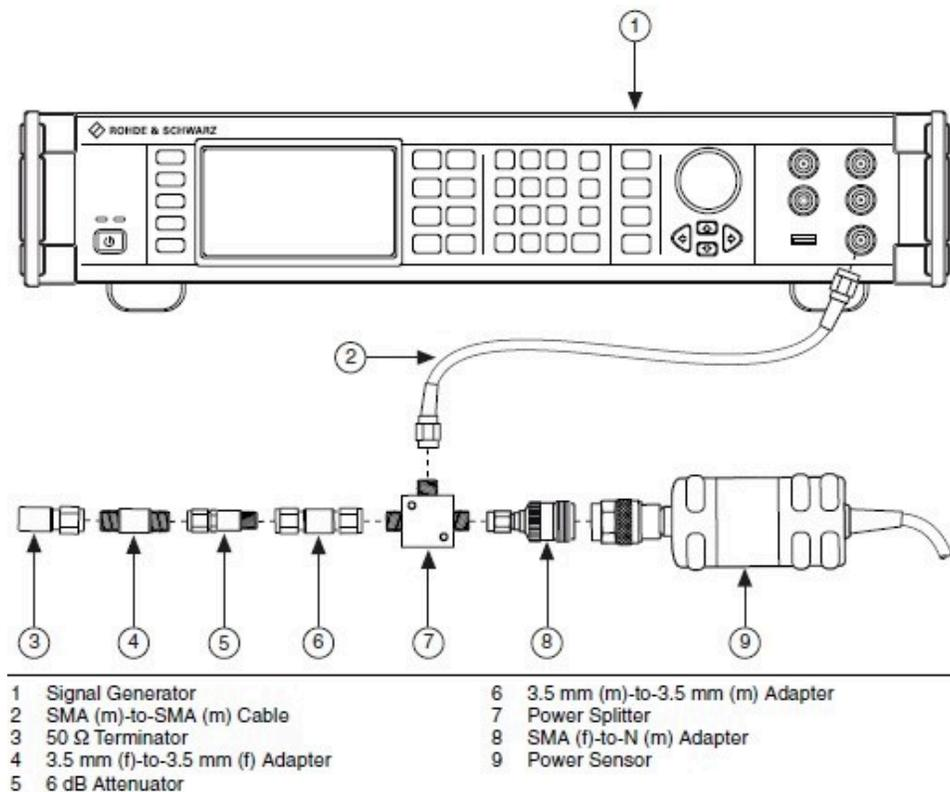

### Related concepts:

- [Launching a Calibration Procedure](#)

## NI 5922 Calibration Procedure

Calibrate the NI 5922 using Calibration Executive.



## Calibration Executive Procedure Features

Verify Only ✓	Verify & Adjust ✓	Manual Mode ✓	Optional Adjust ✗
---------------	-------------------	---------------	-------------------

### Approximate Test Time

15 minutes

### Test Equipment

The following table lists the test equipment required to calibrate the NI 5922.

**Table 312.** Test equipment for calibrating the NI 5922

Instrument	Recommended Model	Requirements
Signal Generator	Fluke 9500B, Wavetek 9500 (with high-stability reference option)	—
Active Head	Fluke 9510	—
DC Source	Fluke 5700A	If this instrument is unavailable, use a high-precision voltage source that measures voltage gain with a DC accuracy of $<\pm 50$ ppm into 1 M $\Omega$ .
Chassis	PXI-1042, PXI-1042Q	Use with PXI modules.
BNC Cable	—	Use a 50 $\Omega$ BNC cable.



**Note** The Calibration Executive procedure runs in automated mode if you use IVI-supported instruments.

### Test Conditions

The following setup and environmental conditions are required to ensure the NI 5922 meets published specifications.

- Always connect the calibrator test head directly to the input BNC of the digitizer, or use a short 50  $\Omega$  BNC coaxial cable if necessary. Long cables and wires act as

antennas, picking up extra noise that can affect measurements.

- Keep relative humidity between 10 and 90% non-condensing, or consult the digitizer hardware documentation for the optimum relative humidity.
- Maintain a temperature of  $23 \pm 5$  °C.
- Allow a warm-up time of at least 15 minutes to ensure that the measurement circuitry of the device is at a stable operating temperature.
- Plug the PXI chassis or PC and the calibrator into the same power strip to avoid ground loops.
- (PXI) Ensure that the PXI chassis fan speed is set to HIGH, that the fan filters are clean, and that the empty slots contain filler panels.

## Device Setup

1. Install the NI 5922 in the PXI chassis according to the instructions in the NI High-Speed Digitizers Getting Started Guide.
2. Configure the hardware using Measurement & Automation Explorer (MAX).
3. Launch the Calibration Executive procedure. Calibration Executive guides you through the required connections.
4. Enter the NI-DAQmx device name, which is assigned by MAX.
5. Follow any additional connection prompts from Calibration Executive.



**Note** The Fluke 9500B/Wavetek 9500 is the only oscilloscope calibrator currently supported through GPIB control. You can run the calibration procedure in manual mode if you have another type of oscilloscope calibrator.



**Note** If the NI 5922 fails verification after the adjustment, return it to NI for repair or replacement.

## Test Limit Equations

The following test limits are derived from the published specifications.

Table 211. NI 5922 Test Limit Equations

Equation Type	Equation
Vertical Gain	$\text{TestLimits} = \text{TestValue} \pm 500 \text{ ppm (0.05\%)}$ <ul style="list-style-type: none"> <li>• 1 M<math>\Omega</math> input impedance</li> <li>• Within <math>\pm 5</math> °C of self-calibration temperature</li> </ul>
Vertical Offset	<p>2 V<sub>pk-pk</sub> Range</p> <ul style="list-style-type: none"> <li>• <math>\text{TestLimits} = \text{TestValue} \pm 50 \mu\text{V}</math> <ul style="list-style-type: none"> <li>◦ 1 M<math>\Omega</math> input impedance</li> <li>◦ Within <math>\pm 5</math> °C of self-calibration temperature</li> </ul> </li> </ul> <p>10 V<sub>pk-pk</sub> Range</p> <ul style="list-style-type: none"> <li>• <math>\text{TestLimits} = \text{TestValue} \pm 100 \mu\text{V}</math> <ul style="list-style-type: none"> <li>◦ 1 M<math>\Omega</math> input impedance</li> <li>◦ Within <math>\pm 5</math> °C of self-calibration temperature</li> </ul> </li> </ul>
Timing	$\text{TestLimits} = \text{TestValue} \pm 50 \text{ ppm}$ <ul style="list-style-type: none"> <li>• Not Phase-Locked to Reference Clock</li> </ul>
Input Bias Current	$\text{TestLimits} = \text{TestValue} \pm 500 \text{ nA}$ <ul style="list-style-type: none"> <li>• Within <math>\pm 5</math> °C of self-calibration temperature</li> </ul>

**Related concepts:**

- [Automated Mode Versus Manual Mode](#)
- [Launching a Calibration Procedure](#)

## Power Measurement Conditioners

Calibrate your power measurement conditioners with Calibration Executive.

## RM-26999 Calibration Procedure

Calibrate the RM-26999 using Calibration Executive.



**Hazardous Voltage** The RM-26999 calibration procedure involves voltages that can be hazardous to users ( $\pm 1000$  VDC). It is the responsibility of the system designer, integrator, installer, maintenance personnel, and service personnel to make sure that the module is used safely.

### Calibration Executive Procedure Features

Verify Only ✓	Adjust Only ✓	Verify & Adjust ✓	Manual Mode ✓	Optional Adjust ✓
---------------	---------------	-------------------	---------------	-------------------

### Approximate Test Time

Verify Only	Adjust Only	Verify & Adjust
95 minutes	20 minutes	205 minutes

The RM-26999 requires a 60-minute warmup period, which is not included in the test time estimates.

### Test Equipment

The following table lists the test equipment required to calibrate the RM-26999.

**Table 212.** Test equipment for calibrating the RM-26999

Instrument	Recommended Model	Where Used	Minimum Requirements
Calibrator	Fluke 5730A	Verifications: <ul style="list-style-type: none"> <li>DC gain</li> <li>AC gain</li> </ul>	DC Range: $\pm 1000$ V DC Accuracy: $\pm 20$ $\mu$ V/V AC Range: $\pm 1000$ V AC Accuracy: <ul style="list-style-type: none"> <li>&lt;100kHz: <math>\pm 0.3\%</math></li> <li>&lt;1MHz: <math>\pm 1.5\%</math></li> </ul>
Calibrator Amp	Fluke 5725A	Verifications:	AC Range: $\pm 1000$ V AC Accuracy:

Instrument	Recommended Model	Where Used	Minimum Requirements
		<ul style="list-style-type: none"> <li>AC gain</li> </ul>	<ul style="list-style-type: none"> <li>&lt;100kHz: <math>\pm 0.3\%</math></li> <li>&lt;1MHz: <math>\pm 1.5\%</math></li> </ul>
DMM	Keysight 3458A	Verifications: <ul style="list-style-type: none"> <li>DC gain</li> <li>AC gain</li> </ul>	DC Range: $\pm 10$ V DC Accuracy: $\pm 20$ $\mu$ V/V AC Range: $\pm 10$ V AC Accuracy: <1MHz: $\pm 0.02\%$
Low Thermal EMF Cable with Banana Plugs	Fluke 5730A-7002	Verifications: <ul style="list-style-type: none"> <li>DC gain</li> <li>AC gain</li> </ul>	—
BNC (f) to Banana Plug Adaptor	Pomona Model 1269	Verifications: <ul style="list-style-type: none"> <li>DC gain</li> <li>AC gain</li> </ul>	—
Power Supply	NI PS-16	Verifications: <ul style="list-style-type: none"> <li>DC gain</li> <li>AC gain</li> </ul>	24 V DC, 5 A
BNC (m) to BNC (m) cable	—	Verifications: <ul style="list-style-type: none"> <li>DC gain</li> <li>AC gain</li> </ul>	—
Calibrator Amp Cable	Fluke 842901	Verifications: <ul style="list-style-type: none"> <li>AC gain</li> </ul>	No substitution
SMIO (DAQ) Module	PXIe-6366, PXIe-6368, PXIe-6376, or PXIe-6378	Verifications: <ul style="list-style-type: none"> <li>DC gain</li> <li>AC gain</li> </ul>	Sampling rate: 2 MS/s

Instrument	Recommended Model	Where Used	Minimum Requirements
DAQ Device Cable	NI SH68F-68F-EPM and SHC68-68-EPM	—	—
Terminal Block	BNC-2090A	Verifications: <ul style="list-style-type: none"> <li>• DC gain</li> <li>• AC gain</li> </ul>	—

## Test Conditions

The following setup and environmental conditions are required to ensure the RM-26999 meets published specifications.

- Keep cabling as short as possible. Long cables act as antennas, picking up extra noise that can affect measurements.
- Verify that all connections to the RM-26999 are secure.
- Allow adequate warm up time for all components of the calibration system.
- Make all connections as shown in diagrams.
- Use shielded copper wire for all cable connections to the RM-26999.
- Use twisted-pair wires to eliminate noise and thermal offsets.
- Ensure that the PXI chassis fan speed is set to HIGH, that the fan filters are clean, and that the empty slots contain filler panels. For more information about cooling, refer to the Maintain Forced-Air Cooling Note to Users document available at [ni.com/docs](http://ni.com/docs).
- Maintain an ambient temperature of  $23\text{ }^{\circ}\text{C} \pm 5\text{ }^{\circ}\text{C}$ .
- Keep relative humidity between 20% and 80%, non-condensing.
- Follow the manufacturers' specific usage requirements of the DMM that affect the accuracy of the function used. Not following the manufacturers' requirements results in a worse Test Uncertainty Ratio (TUR). For the Keysight 3458A, refer to [ni.com/docs](http://ni.com/docs) for important information about device setup, connection procedures, and safety guidance.

## Device Setup

1. Before you set up the RM-26999, find and record the serial number of the device.

- The serial number is located on a label on the device.
2. Install the RM-26999 device according to the instructions in the RM-26999 User Manual.
  3. Install the PS-16 power supply according to the instructions in the NI PS-16 Power Supply User Manual available at [ni.com/docs](http://ni.com/docs).
  4. Configure BNC-2090A for Differential Measurements. Refer to the BNC-2090A Quick Start Guide at [ni.com/docs](http://ni.com/docs) for important information.

Figure 1. Connection Diagram for Initial Measurement of DC Gain

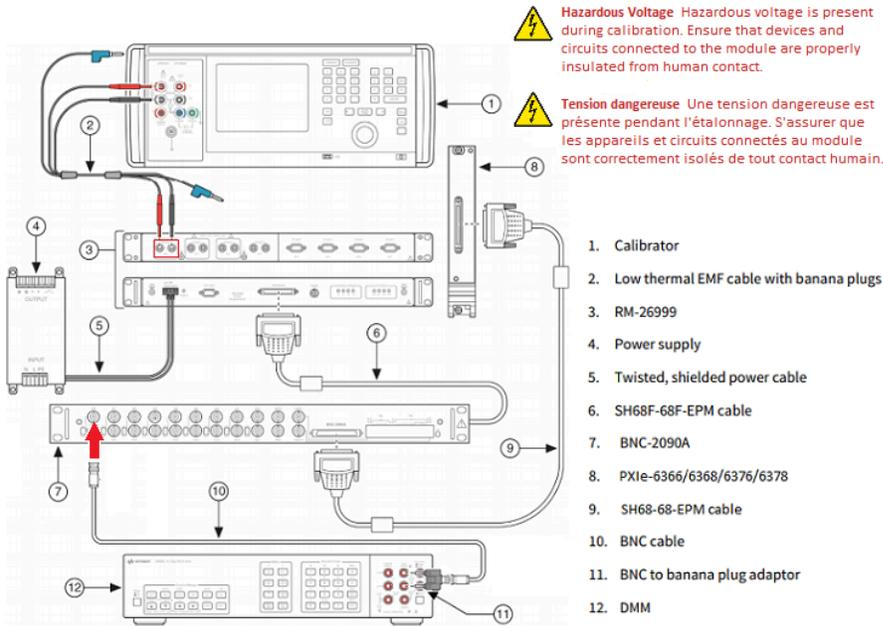

Figure 1. Connection Diagram for Initial Measurement of AC Gain

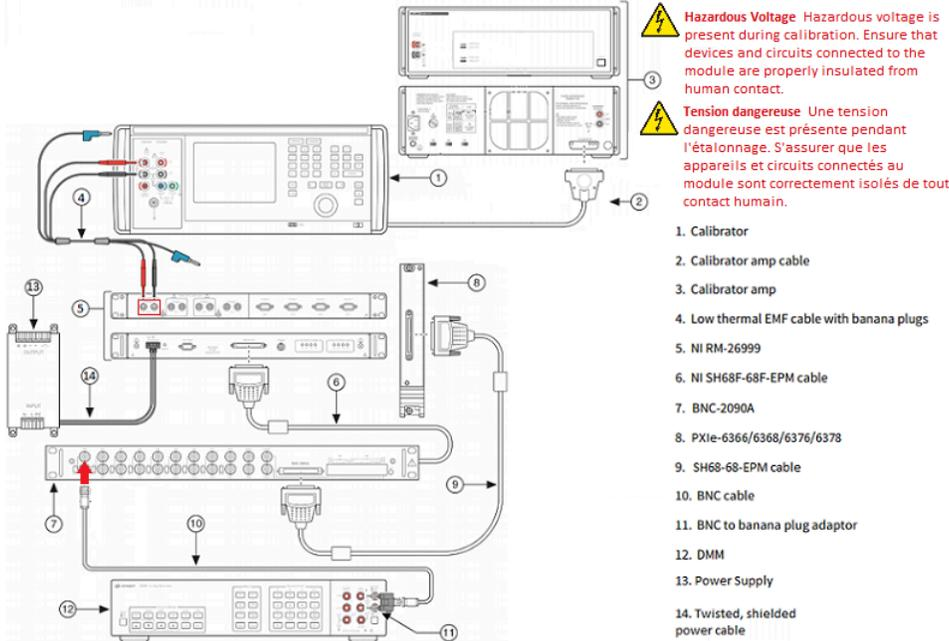

Figure 1. Connection Diagram for DC Gain and Offset Adjustment

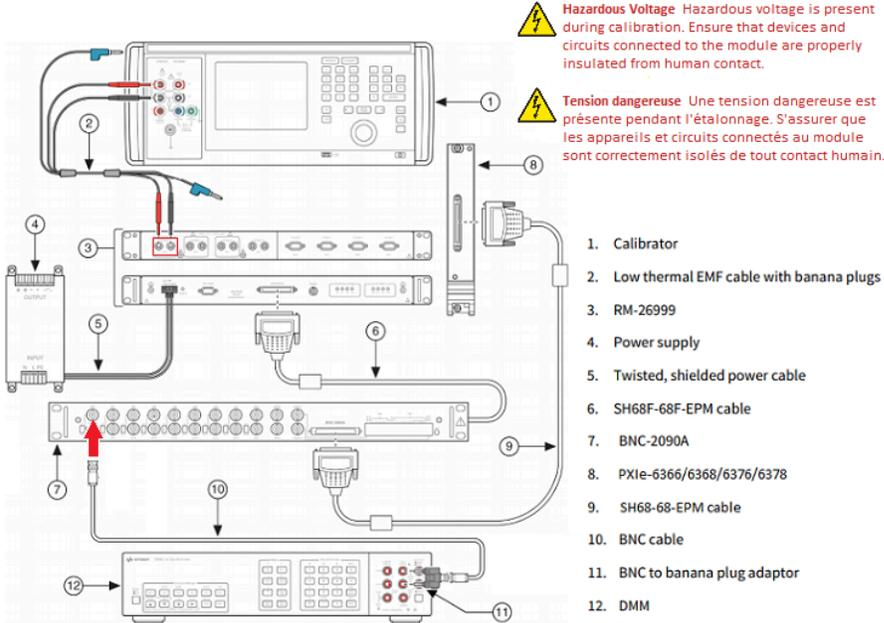



Figure 1. Connection Diagram for AC Gain Adjustment Initial Setup

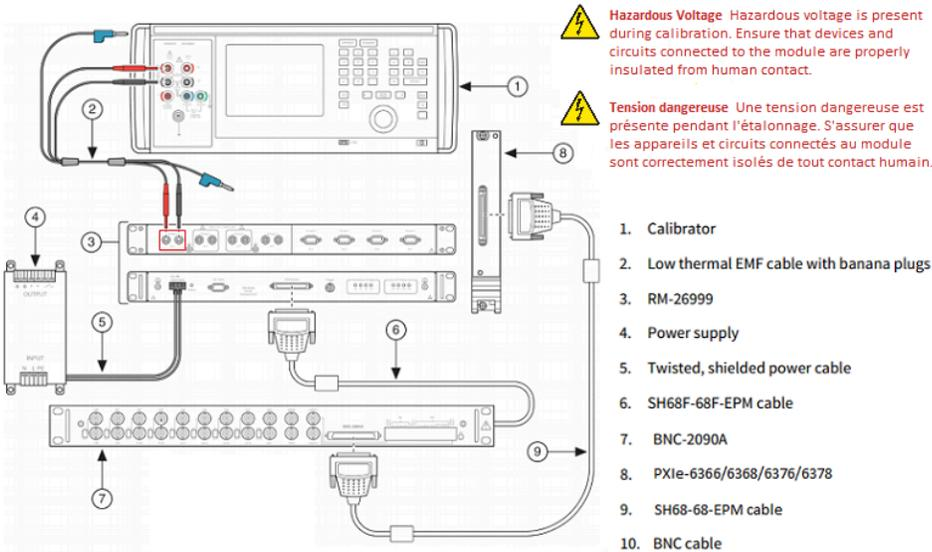
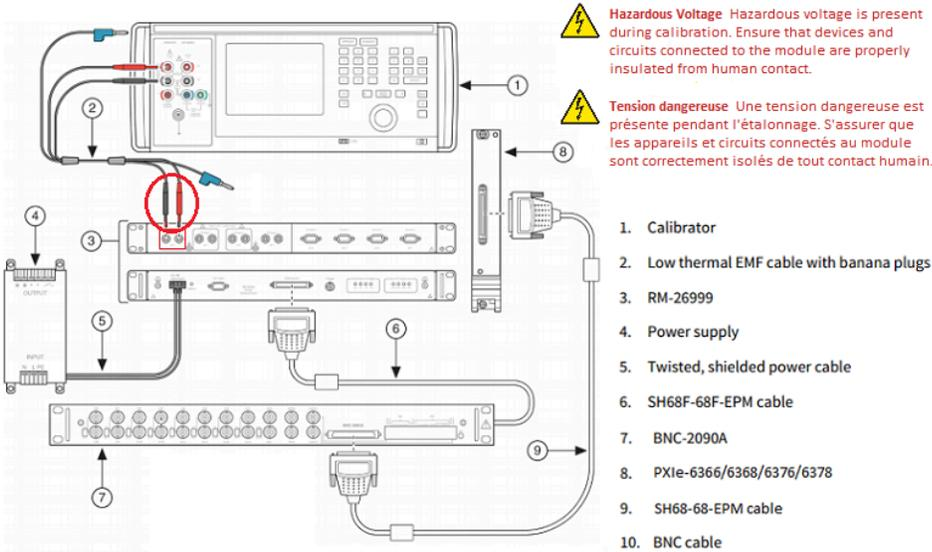

Figure 1. Connection Diagram for AC Gain Adjustment Connection Change



### Test Limit Equations

The following As-Found test limits are derived from the published specifications.

$$\text{DC Gain Test Limit} = \pm[(\text{Test Value} \times \text{Accuracy}) + (\text{DC Offset} \times \text{Attenuation})]$$

AC Gain Test Limits =  $\pm[(\text{Test Value} \times \text{Accuracy}) + \text{Noise Contribution}]$

## Considerations for the Keysight 3458A Digital Multimeter

Follow the manufacturer's specific usage requirements for the Keysight 3458A DMM to ensure the accuracies of the measurements are sufficient for the calibration procedure. Refer to the Keysight documentation for more details.

Calibration Executive manages many of the Keysight 3458A measurement settings automatically, however you must check the following conditions manually prior to using the device.

- Autocal must be performed every 24 hours and if the internal temperature of the DMM changes more than 1 °C from the internal temperature of last Autocal.
- The internal temperature must be within  $\pm 5$  °C of last external calibration temperature ( $T_{\text{cal}}$ ).

The following tables list various temperatures, their requirements, and the SCPI commands you can use to query their values. Use the VISA Interactive Control tool included in NI MAX to query using the SCPI commands.

**Table 226.** SCPI commands to query Keysight 3458A internal and Autocal temperatures

Definition	Notes	SCPI Command	Requirement
Internal instrument temperature	Dynamic, Immediate	TEMP?	—
Autocal	—, approximately 18 minutes	ACAL ALL	—

**Table 227.** SCPI commands to query Keysight 3458A  $T_{\text{cal}}$  temperatures

Definition	Notes	SCPI Command	Requirement
'Cal 0 temperature'	Fixed at time of adjust	CAL? 58	within $\pm 5$ °C of TEMP?
'Cal 10 temp' or 10 VDC $T_{\text{cal}}$ temperature	Fixed at time of adjust	CAL? 59	within $\pm 5$ °C of TEMP?
'Cal 10k temp' or 10 k $\Omega$ $T_{\text{cal}}$ temperature	Fixed at time of adjust	CAL? 60	within $\pm 5$ °C of TEMP?

**Table 228.** SCPI commands to query Keysight 3458A ACAL temperatures

Definition	Notes	SCPI Command	Requirement
'ACAL DCV temperature'	Changes after ACAL cmd	CAL? 175	within $\pm 1$ °C of TEMP?
'ACAL OHM temperature'	Changes after ACAL cmd	CAL? 176	within $\pm 1$ °C of TEMP?
'ACAL ACV temperature'	Changes after ACAL cmd	CAL? 177	within $\pm 1$ °C of TEMP?

## Power Supplies and SMUs

Calibrate your power supplies and SMUs with Calibration Executive.

### PXI-4110 Calibration Procedure

Calibrate the PXI-4110 using Calibration Executive.

### Calibration Executive Procedure Features

Verify Only ✓	Verify & Adjust ✓	Manual Mode ✓	Optional Adjust ✗
---------------	-------------------	---------------	-------------------

### Approximate Test Time

70 minutes

### Test Equipment

The following table lists the test equipment required for calibrating the PXI-4110.

**Table 312.** Test equipment for calibrating the PXI-4110

Instrument	Recommended Model	Requirements
DMM	PXI-4071, PXIe-4081	Voltage: $\leq \pm 50$ ppm accuracy, $\leq 30$ $\mu$ V resolution; Current: $\leq \pm 0.04\%$ accuracy, $\leq 50$ nA resolution
External Load	IET Labs HPRS-F-6-1	Power resistor decade box with a range of 3 to 25,000 $\Omega$ and an accuracy of $\pm 10\%$ , and a minimum power rating of 40 W per decade

Instrument	Recommended Model	Requirements
Chassis	PXI-1042, PXI-1042Q	—
Auxiliary power supply	NI APS-4100	11 V to 15.5 V, 5 A
Twisted pair, shielded cabling wire	—	18 AWG to 22 AWG
Variable power supply	Xantrex HPD 30-10 or RMX-4102 (Manual Mode only)	Variable between 11 V and 15.5 V, 5 A*



**Note** \*If using the RMX-4102, it must be a model variant that supports at least 5 A current.

## Test Conditions

The following setup and environmental conditions are required to ensure the PXI-4110 meets published specifications.

- Keep cabling wire as short as possible. Long cables and wires act as antennas, picking up extra noise that can affect measurement. To further reduce noise, twist signal/common wires together.
- Verify that all connections, including front panel connections, are secure.
- Keep relative humidity between 10 and 90%, non-condensing.
- Maintain an ambient temperature of  $23\text{ }^{\circ}\text{C} \pm 5\text{ }^{\circ}\text{C}$ .
- Allow a warm-up time of at least 15 minutes after the NI-DCPower driver is loaded. Unless manually disabled, the NI-DCPower driver automatically loads with the operating system and enables the device. The warm-up time ensures that the measurement circuitry of the PXI-4110 is at a stable operating temperature.
- Ensure that the PXI chassis fan speed is set to HIGH, that the fan filters are clean, and that the empty slots contain filler panels.

## Device Setup

1. Install the PXI-4110 in the PXI chassis according to the instructions in the **NI DC**

### ***Power Supplies and SMUs Getting Started Guide.***

2. Configure the hardware using Measurement & Automation Explorer (MAX).
3. Launch the Calibration Executive procedure and complete the setup wizard.



**Note** If the PXI-4110 module fails after calibration, return it to NI for repair or replacement.

## Test Limit Equations

The following test limits are derived from the published specifications.

**Table 217.** PXI-4110 Test Limit Equations

Equation Type	Equation
Voltage Programming Accuracy	$\text{TestLimits} = \text{TestValue} \pm \text{AbsoluteAccuracy}$ <ul style="list-style-type: none"> <li>• <math>\text{AbsoluteAccuracy} = \text{TestValue} \times \text{GainError} (\%) + \text{Range} \times \text{OffsetError} (V)</math></li> </ul>
Voltage Measurement Accuracy	$\text{TestLimits} = \text{TestValue} \pm \text{AbsoluteAccuracy}$ <ul style="list-style-type: none"> <li>• <math>\text{AbsoluteAccuracy} = \text{TestValue} \times \text{GainError} (\%) + \text{Range} \times \text{OffsetError} (V)</math></li> </ul>
Current Output Accuracy	$\text{TestLimits} = \text{TestValue} \pm \text{AbsoluteAccuracy}$ <ul style="list-style-type: none"> <li>• <math>\text{AbsoluteAccuracy} = \text{TestValue} \times \text{GainError} (\%) + \text{Range} \times \text{OffsetError} (V)</math></li> </ul>
Current Measurement Accuracy	$\text{TestLimits} = \text{TestValue} \pm \text{AbsoluteAccuracy}$ <ul style="list-style-type: none"> <li>• <math>\text{AbsoluteAccuracy} = \text{TestValue} \times \text{GainError} (\%) + \text{Range} \times \text{OffsetError} (V)</math></li> </ul>
Voltage Load Regulation	<p>(in case of channel 0)</p> <ul style="list-style-type: none"> <li>• <math>\text{VoltageChangeLimit} = \pm(I_1 - I_2) \times 0.0252</math></li> </ul> <p>(in case of channel 1 and 2)</p>

Equation Type	Equation
	<ul style="list-style-type: none"> <li>• <math>\text{VoltageChangeLimit} = \pm(I_1 - I_2) \times 0.02</math></li> </ul> <p>where</p> <ul style="list-style-type: none"> <li>• <math>I_1</math> is the current measurement taken with the first specified resistance</li> <li>• <math>I_2</math> is the current measurement taken with the second specified resistance</li> </ul>
Current Load Regulation	<p>(in case of channel 0, and 1 A current range)</p> <ul style="list-style-type: none"> <li>• <math>\text{CurrentChangeLimit} = \pm 2.00 \times 10^{-4} \times (V_1 - V_2)</math></li> </ul> <p>(in case of channel 1 and 2, and 20 mA current range)</p> <ul style="list-style-type: none"> <li>• <math>\text{CurrentChangeLimit} = \pm 6.00 \times 10^{-7} \times (V_1 - V_2)</math></li> </ul> <p>(in case of channel 1 and 2, and 1 A current range)</p> <ul style="list-style-type: none"> <li>• <math>\text{CurrentChangeLimit} = \pm 7.00 \times 10^{-5} \times (V_1 - V_2)</math></li> </ul> <p>where</p> <ul style="list-style-type: none"> <li>• <math>V_1</math> is the voltage measurement taken with the first specified resistance</li> <li>• <math>V_2</math> is the voltage measurement taken with the second specified resistance</li> </ul>
Voltage Line Regulation	<p>(in case of channel 1 and 2)</p> <ul style="list-style-type: none"> <li>• <math>\text{VoltageChangeLimit} = \pm ((V_1 \times 1.00 \times 10^{-4}) + 1.00 \times 10^{-3}) \times (V_{\text{ext}1} - V_{\text{ext}2})</math></li> <li>• where</li> </ul>

Equation Type	Equation
	<ul style="list-style-type: none"> <li>◦ <math>V_1</math> is the voltage measurement across the output of the specified channel</li> <li>◦ <math>V_{\text{ext}1}</math> is the first specified voltage generated by the external variable power supply (15.5 V)</li> <li>◦ <math>V_{\text{ext}2}</math> is the second specified voltage generated by the external variable power supply (11 V)</li> </ul>
Current Line Regulation	<p>in case of channel 1 and 2, and 20 mA current range)</p> <ul style="list-style-type: none"> <li>• <math>\text{CurrentChangeLimit} = \pm((I_1 \times 1.00 \times 10^{-4}) + 4.00 \times 10^{-6}) \times (V_{\text{ext}1} - V_{\text{ext}2})</math></li> </ul> <p>(in case of channel 1 and 2, and 1 A current range)</p> <ul style="list-style-type: none"> <li>• <math>\text{CurrentChangeLimit} = \pm((I_1 \times 1.00 \times 10^{-4}) + 2.00 \times 10^{-4}) \times (V_{\text{ext}1} - V_{\text{ext}2})</math></li> </ul> <p>where</p> <ul style="list-style-type: none"> <li>• <math>I_1</math> is the current measurement across the output of the specified channel</li> <li>• <math>V_{\text{ext}1}</math> is the first specified voltage generated by the external variable power supply (15.5 V)</li> <li>• <math>V_{\text{ext}2}</math> is the second specified voltage generated by the external variable power supply (11 V)</li> </ul>

### Related concepts:

- [Launching a Calibration Procedure](#)

## PXIe-4112/4113 Calibration Procedure

Calibrate the PXIe-4112/4113 using Calibration Executive.

### Calibration Executive Procedure Features

Verify Only ✓	Verify & Adjust ✓	Manual Mode ✓	Optional Adjust ✗
---------------	-------------------	---------------	-------------------

### Approximate Test Time

<b>Warmup</b>	<b>Verify &amp; Adjust</b>
30 minutes	40 minutes

### Test Equipment

The following table lists the test equipment required for calibrating the PXIe-4112.

**Table 312.** Test Equipment for calibrating the PXIe-4112

Instrument	Recommended Model	Parameter Measured	Minimum Requirements
Auxiliary power source	Auxiliary power source for PXIe-411x, part number 154978A-01	—	—
Two (2) DMMs	PXI-4071	All parameters	Voltage: better than $\pm 200$ ppm accuracy and better than $30 \mu\text{V}$ resolution Current: better than $\pm 0.05\%$ accuracy and better than $4 \mu\text{A}$ resolution
Programmable electronic load	Agilent N3302A or Sorensen SLM-60-30-150	Load regulation	Constant Current (CC) and Constant Voltage (CV) modes: sink at least 1 A at 60 V and 6 A at 10 V
Two (2) $1 \Omega$ resistors	Vishay RS02C1R000BBB12	Load regulation, remote sense output	0.1% tolerance, 2.5 W



Instrument	Recommended Model	Parameter Measured	Minimum Requirements
Two (2) 50 $\Omega$ resistors	Vishay PTF5650R000BZED	Load regulation, remote sense output	0.1% tolerance, 1/8 W
Two (2) 100 $\Omega$ resistors	Vishay PTF65100R00BYEK	Load regulation, remote sense output	0.1% tolerance, 1/4 W
1 k $\Omega$ resistor	Vishay PTF651K0000BYEK	Load regulation, remote sense output	0.1% tolerance, 1/4 W

The following table lists the test equipment required for calibrating the PXIe-4113.

**Table 312.** Test Equipment for calibrating the PXIe-4113

Instrument	Recommended Model	Parameter Measured	Minimum Requirements
Auxiliary power source	Auxiliary power source for PXIe-411x, part number 154978A-01	—	—
Two (2) DMMs	PXI-4071	All parameters	Voltage: better than $\pm 200$ ppm accuracy and better than 30 $\mu\text{V}$ resolution  Current: better than $\pm 0.05\%$ accuracy and better than 4 $\mu\text{A}$ resolution
Programmable electronic load	Agilent N3302A	Load regulation	Constant Current (CC) and Constant Voltage (CV) modes: sink at least 1 A at 60 V and 6 A at 10 V
100 m $\Omega$ precision current shunt	Guildline 9230A-15R or Ohm Labs Cs10	Current output and measurement, remote sense output	$\pm 50$ ppm stability, $\pm 5$ ppm/C temperature coefficient

Instrument	Recommended Model	Parameter Measured	Minimum Requirements
			Minimum current: 10 A
Two (2) 0.15 $\Omega$ resistors	Vishay RH010R1500FC02	Load regulation, remote sense output	1% tolerance, 12.5 W
Two (2) 50 $\Omega$ resistors	Vishay PTF5650R000BZED	Load regulation, remote sense output	0.1% tolerance, 1/8 W
1 k $\Omega$ resistor	Vishay PTF651K0000BYEK	Load regulation, remote sense output	0.1% tolerance, 1/4 W

## Test Conditions

The following setup and environmental conditions are required to ensure the PXIe-4112/4113 meets published specifications.

- Keep connections to the device as short as possible. Long cables and wires act as antennas, picking up extra noise that can affect measurements.
- Verify that all connections to the device, including front panel connections, are secure.
- Ensure that the PXI Express chassis fan speed is set to HI, that the fan filters are clean, and that the empty slots contain filler panels. For more information, refer to the ***Maintain Forced-Air Cooling Note to Users*** document available at [ni.com/docs](http://ni.com/docs).
- For verification procedures, maintain an ambient temperature of 23 °C  $\pm$ 5 °C. For adjustment procedures, maintain an ambient temperature of 23 °C  $\pm$ 1 °C. The NI 4113 temperature will be greater than the ambient temperature.
- Keep relative humidity between 10% and 70%, noncondensing.
- Allow the PXIe-4112/4113 to warm up for at least 30 minutes after the NI-DCPower driver is loaded. Unless manually disabled, the NI-DCPower driver automatically loads with the operating system and enables the device.
- Allow the DMM to warm up for its recommended warm up interval.
- Set the NI-DCPower Aperture Time property/attribute to 1PLC.

- Use shielded copper wire for all cable connections to the device. Use twisted-pair wire to eliminate noise and thermal offsets.
- Plug the chassis and the instrument standard into the same power strip to avoid ground loops.



**Note** For Revision F and later versions of the device, NI-DCPower 15.0 or later is required to perform calibration.

## Device Setup

1. Install the PXIe-4112/4113 in the PXI chassis according to the instructions in the ***NI DC Power Supplies and SMUs Getting Started Guide***.
2. Configure the hardware using Measurement & Automation Explorer (MAX).
3. Launch the Calibration Executive procedure and complete the setup wizard.



**Note** If the PXIe-4112/4113 module fails after calibration, return it to NI for repair or replacement.

## Test Limit Equations

The following test limits are derived from the published specifications.

**Table 220.** PXIe-4112 Test Limit Equations

Equation Type	Equation
Voltage Output and Measurement Verification	$\text{TestLimits} = \text{TestLimit} \pm \text{MeasurementTestLimit}$ <ul style="list-style-type: none"> <li>• where           <ul style="list-style-type: none"> <li>◦ <math>\text{MeasurementTestLimit} = \text{ABS}(\text{TestPoint} * \text{Scale}) + \text{Offset}</math> <ul style="list-style-type: none"> <li>▪ Scale = 0.1%</li> <li>▪ Offset = 50 mV</li> </ul> </li> </ul> </li> </ul>
Current Output and Measurement Verification	$\text{TestLimits} = \text{TestLimit} \pm \text{MeasurementTestLimit}$ <ul style="list-style-type: none"> <li>• where           <ul style="list-style-type: none"> <li>◦ <math>\text{MeasurementTestLimit} = \text{ABS}(\text{TestPoint}</math></li> </ul> </li> </ul>

Equation Type	Equation
	<ul style="list-style-type: none"> <li>* Scale) + Offset                             <ul style="list-style-type: none"> <li>▪ Scale = 0.15%</li> <li>▪ Offset = 4 mV</li> </ul> </li> </ul>
Voltage Load Regulation	$\text{VoltageChangeLimit} = \pm(I1 - I2) * 0.012 \text{ V/A}$ <ul style="list-style-type: none"> <li>• where                             <ul style="list-style-type: none"> <li>◦ I1 is the current measurement taken with the first specified resistance</li> <li>◦ I2 is the current measurement taken with the second specified resistance</li> </ul> </li> </ul>
Current Load Regulation Verification	$\text{CurrentChangeLimit} = (V1 - V2) * 0.000032 \text{ A/V}$ <ul style="list-style-type: none"> <li>• where                             <ul style="list-style-type: none"> <li>◦ V1 is the voltage measurement taken with the first specified resistance</li> <li>◦ V2 is the voltage measurement taken with the second specified resistance</li> </ul> </li> </ul>
Voltage Remote Sense Accuracy Verification	$\text{TestLimits} = \text{TestValue} \pm \text{MeasurementTestLimit}$ <ul style="list-style-type: none"> <li>• MeasurementTestLimit = ABS(TestPoint * Scale) + Offset                             <ul style="list-style-type: none"> <li>◦ Scale = 0.12%</li> <li>◦ Offset = 55 mV</li> </ul> </li> </ul>
Current Remote Sense Accuracy Verification	$\text{TestLimits} = \text{TestValue} \pm \text{MeasurementTestLimit}$ <ul style="list-style-type: none"> <li>• MeasurementTestLimit = ABS(TestPoint * Scale) + Offset                             <ul style="list-style-type: none"> <li>◦ Scale = 0.15%</li> <li>◦ Offset = 10 mV</li> </ul> </li> </ul>

**Table 221.** PXIe-4113 Test Limit Equations

Equation Type	Equation
Voltage Output and Measurement Verification	$\text{TestLimits} = \text{TestLimit} \pm \text{MeasurementTestLimit}$

Equation Type	Equation
	<ul style="list-style-type: none"> <li>• where               <ul style="list-style-type: none"> <li>◦ <math>\text{MeasurementTestLimit} = \text{ABS}(\text{TestPoint} * \text{Scale}) + \text{Offset}</math> <ul style="list-style-type: none"> <li>▪ <math>\text{Scale} = 0.1\%</math></li> <li>▪ <math>\text{Offset} = 15 \text{ mV}</math></li> </ul> </li> </ul> </li> </ul>
Current Output and Measurement Verification	$\text{TestLimits} = \text{TestLimit} \pm \text{MeasurementTestLimit}$ <ul style="list-style-type: none"> <li>• where               <ul style="list-style-type: none"> <li>◦ <math>\text{MeasurementTestLimit} = \text{ABS}(\text{TestPoint} * \text{Scale}) + \text{Offset}</math> <ul style="list-style-type: none"> <li>▪ <math>\text{Scale} = 0.15\%</math></li> <li>▪ <math>\text{Offset} = 20 \text{ mV}</math></li> </ul> </li> </ul> </li> </ul>
Voltage Load Regulation	$\text{VoltageChangeLimit} = \pm(I1 - I2) * 0.0005 \text{ V/A}$ <ul style="list-style-type: none"> <li>• where               <ul style="list-style-type: none"> <li>◦ I1 is the current measurement taken with the first specified resistance</li> <li>◦ I2 is the current measurement taken with the second specified resistance</li> </ul> </li> </ul>
Current Load Regulation Verification	$\text{CurrentChangeLimit} = (V1 - V2) * 0.00025 \text{ A/V}$ <ul style="list-style-type: none"> <li>• where               <ul style="list-style-type: none"> <li>◦ V1 is the voltage measurement taken with the first specified resistance</li> <li>◦ V2 is the voltage measurement taken with the second specified resistance</li> </ul> </li> </ul>
Voltage Remote Sense Accuracy Verification	$\text{TestLimits} = \text{TestValue} \pm \text{MeasurementTestLimit}$ <ul style="list-style-type: none"> <li>• <math>\text{MeasurementTestLimit} = \text{ABS}(\text{TestPoint} * \text{Scale}) + \text{Offset}</math> <ul style="list-style-type: none"> <li>◦ <math>\text{Scale} = 0.1\%</math></li> <li>◦ <math>\text{Offset} = 15 \text{ mV}</math></li> </ul> </li> </ul>
Current Remote Sense Accuracy Verification	$\text{TestLimits} = \text{TestValue} \pm \text{MeasurementTestLimit}$

Equation Type	Equation
	<ul style="list-style-type: none"> <li>• MeasurementTestLimit = ABS(TestPoint * Scale) + Offset <ul style="list-style-type: none"> <li>◦ Scale = 0.15%</li> <li>◦ Offset = 20 mV</li> </ul> </li> </ul>

### Related concepts:

- [Launching a Calibration Procedure](#)

## PXI-4130 Calibration Procedure

Calibrate the NI PXI-4130 using Calibration Executive.

### Calibration Executive Procedure Features

Verify Only ✓	Verify & Adjust ✓	Manual Mode ✓	Optional Adjust ✗
---------------	-------------------	---------------	-------------------

### Approximate Test Time

70 minutes

### Test Equipment

The following table lists the test equipment required for calibrating the PXI-4130.

**Table 312.** Test equipment for calibrating the PXI-4130

Instrument	Recommended Model	Requirements
DMM	NI 4071	Voltage: better than $\pm 50$ ppm accuracy, better than $\pm 30$ $\mu$ V resolution; Current: better than $\pm 0.04\%$ accuracy, better than 1 $\mu$ A resolution
External load	IET Labs HPRS-F-6-1	Power resistor decade box with a range of 4 to

Instrument	Recommended Model	Requirements
		48,000 $\Omega$ and an accuracy of $\pm 10\%$
External calibrator	Fluke 5700A/5720A/5730A	—
Chassis	PXI-1042, PXI-1042Q	—
Auxiliary power supply	NI APS-4100	11 V to 15.5 V, 5 A
Variable power supply	Xantrex HPD 30-10 or RMX-4102 (Manual Mode only)	Variable between 11 V and 15.5 V, 5 A*
Twisted pair, shielded cabling wire	Belden 83319E 009100	18 AWG to 22 AWG
Resistors	—	Two 50 $\Omega$ , 1/4 W $\pm 10\%$ resistors, and one 1 k $\Omega$ , 1/4 W $\pm 10\%$ resistor



**Note** \*If using the RMX-4102, it must be a model variant that supports at least 5 A current.



**Note** The NI 4071 is the only DMM supported in automated mode.

The following table lists the calibration equipment configuration for voltage programming and measurement verification/adjustment.

PXI-4130	DMM*			
Channel(s)	Range	Function	Range	Input Impedance†
0	6 V	DC Voltage	10 V	10 G $\Omega$
1	6 V		10 V	10 G $\Omega$
	20 V		100 V	10 M $\Omega$



**Note**

- \*Use the highest resolution available on the DMM. The DMM should have a minimum of 6.5 digit resolution.
- †Assumes an NI 4071 DMM. For all other DMMs, use the range and input impedance closest to the values listed in this table.

The following table lists the calibration equipment configuration for current programming and measurement verification/adjustment.

PXI-4130		DMM*				Calibrator Resistance
Channel	Range	Function	Range	Input Impedance	Resolution in Digits	
0	1 A	DC Current	1 A	N/A	6.5	N/A
1	200 $\mu$ A	DC Voltage	10 V	10 G $\Omega$	7.5	10 k $\Omega$
	2 mA	DC Voltage	10 V	10 G $\Omega$	7.5	1 k $\Omega$
	20 mA	DC Voltage	10 V	10 G $\Omega$	7.5	100 $\Omega$
	200 mA	DC Voltage	10 V	10 G $\Omega$	7.5	10 $\Omega$
	2 A	DC Current	3 A	N/A	6.5	N/A



**Note** \*Use the highest resolution available on the DMM.

## Test Conditions

The following setup and environmental conditions are required to ensure the PXI-4130 meets published specifications.

- Keep cabling wire as short as possible. Long cables and wires act as antennas,



picking up extra noise that can affect measurement. To further reduce noise, twist signal/common wires together.

- Verify that all connections, including front panel connections, are secure.
- Keep relative humidity between 10 and 90%, non-condensing.
- Maintain an ambient temperature of  $23 \pm 5$  °C.
- Allow a warm-up time of at least 30 minutes after the NI-DCPower driver is loaded. Unless manually disabled, the NI-DCPower driver automatically loads with the operating system and enables the device. The warm-up time ensures that the measurement circuitry of the PXI-4130 is at a stable operating temperature.
- Ensure that the PXI chassis fan speed is set to HIGH, that the fan filters are clean, and that the empty slots contain filler panels.

## Device Setup

1. Install the PXI-4130 in the PXI chassis according to the instructions in the NI DC Power Supplies and SMUs Getting Started Guide.
2. Configure the hardware using Measurement & Automation Explorer (MAX).
3. Launch the Calibration Executive procedure and complete the setup wizard.



**Note** If the PXI-4130 module fails after calibration, return it to NI for repair or replacement. In the PXI-4130 calibration report, the Low and High Limit columns list the error limits and the Reading column lists the actual Test Point error/accuracy.

## Test Limit Equations

The following test limits are derived from the published specifications.

**Table 223.** PXIe-4120 Test Limit Equations

Equation Type	Equation
Voltage Programming Accuracy, Voltage Measurement Accuracy, Current Programming Accuracy, Current Measurement Accuracy	$\text{TestLimits} = \text{TestValue} \pm [\text{abs}(\text{TestValue}) * \% \text{ of reading} + \text{offset}]$
Voltage Load Regulation	(in case of channel 0) <ul style="list-style-type: none"> <li>• <math>\text{VoltageChangeLimit} = \pm(I1 - I2) * 0.0252</math></li> </ul>

Equation Type	Equation
	<p>(in case of channel 1)</p> <ul style="list-style-type: none"> <li>• <math>\text{VoltageChangeLimit} = \pm(I1 - I2) * 0.02</math></li> </ul> <p>where</p> <ul style="list-style-type: none"> <li>• I1 is the current measurement taken with the first specified resistance</li> <li>• I2 is the current measurement taken with the second specified resistance</li> </ul>
Current Load Regulation	<p>(in case of channel 0 and 1 A current range)</p> <ul style="list-style-type: none"> <li>• <math>\text{CurrentChangeLimit} = \pm 2.00 * 10^{-4} * (V1 - V2)</math></li> </ul> <p>(in case of channel 1 and 200 <math>\mu\text{A}</math> current range)</p> <ul style="list-style-type: none"> <li>• <math>\text{CurrentChangeLimit} = \pm 2.00 * 10^{-8} * (V1 - V2)</math></li> </ul> <p>(in case of channel 1 and 2 mA current range)</p> <ul style="list-style-type: none"> <li>• <math>\text{CurrentChangeLimit} = \pm 2.00 * 10^{-7} * (V1 - V2)</math></li> </ul> <p>(in case of channel 1 and 20 mA current range)</p> <ul style="list-style-type: none"> <li>• <math>\text{CurrentChangeLimit} = \pm 2.00 * 10^{-6} * (V1 - V2)</math></li> </ul> <p>(in case of channel 1 and 200 mA current range)</p> <ul style="list-style-type: none"> <li>• <math>\text{CurrentChangeLimit} = \pm 2.00 * 10^{-5} * (V1 - V2)</math></li> </ul> <p>(in case of channel 1 and 2 A current range)</p> <ul style="list-style-type: none"> <li>• <math>\text{CurrentChangeLimit} = \pm 2.00 * 10^{-4} * (V1 - V2)</math></li> </ul> <p>where</p> <ul style="list-style-type: none"> <li>• V1 is the voltage measurement taken with the first specified resistance</li> <li>• V2 is the voltage measurement taken with</li> </ul>

Equation Type	Equation
	the second specified resistance
Voltage Line Regulation	<p>(in case of channel 1)</p> <ul style="list-style-type: none"> <li>• <math>\text{VoltageChangeLimit} = \pm((V1 * 1.00 * 10^{-4}) + 0.001) * (Vext1 - Vext2)</math> <ul style="list-style-type: none"> <li>◦ where           <ul style="list-style-type: none"> <li>▪ V1 is the voltage measurement across the output of the specified channel</li> <li>▪ Vext1 is the first specified voltage generated by the external variable power supply (15.5 V)</li> <li>▪ Vext2 is the second specified voltage generated by the external variable power supply (11 V)</li> </ul> </li> </ul> </li> </ul>
Current Line Regulation	<p>(in case of channel 1 and 200 <math>\mu\text{A}</math> current range)</p> <ul style="list-style-type: none"> <li>• <math>\text{CurrentChangeLimit} = \pm((I1 * 1.00 * 10^{-4}) + 4.00 * 10^{-8}) * (Vext1 - Vext2)</math></li> </ul> <p>(in case of channel 1 and 2 mA current range)</p> <ul style="list-style-type: none"> <li>• <math>\text{CurrentChangeLimit} = \pm((I1 * 1.00 * 10^{-4}) + 4.00 * 10^{-7}) * (Vext1 - Vext2)</math></li> </ul> <p>(in case of channel 1 and 20 mA current range)</p> <ul style="list-style-type: none"> <li>• <math>\text{CurrentChangeLimit} = \pm((I1 * 1.00 * 10^{-4}) + 4.00 * 10^{-6}) * (Vext1 - Vext2)</math></li> </ul> <p>(in case of channel 1 and 200 mA current range)</p> <ul style="list-style-type: none"> <li>• <math>\text{CurrentChangeLimit} = \pm((I1 * 1.00 * 10^{-4}) + 4.00 * 10^{-5}) * (Vext1 - Vext2)</math></li> </ul>

Equation Type	Equation
	<p>(in case of channel 1 and 2 A current range)</p> <ul style="list-style-type: none"> <li>• <math>\text{CurrentChangeLimit} = \pm((I1 * 1.00 * 10^{-4}) + 4.00 * 10^{-4}) * (\text{Vext1} - \text{Vext2})</math></li> </ul> <p>where</p> <ul style="list-style-type: none"> <li>• I1 is the current measurement across the output of the specified channel</li> <li>• Vext1 is the first specified voltage generated by the external variable power supply (15.5 V)</li> <li>• Vext2 is the second specified voltage generated by the external variable power supply (11 V)</li> </ul>
Remote Sense Output	<p><math>\text{LoadVoltageLimit} = 10 \text{ V} \pm (0.0052 \text{ V} + (0.000120 \text{ V} * (\text{HILeadDrop} + \text{LOLeadDrop})))</math></p> <ul style="list-style-type: none"> <li>• where <ul style="list-style-type: none"> <li>◦ HILeadDrop is the value measured by DMM Measurement 1</li> <li>◦ LOLeadDrop is the value measured by DMM Measurement 3</li> </ul> </li> </ul>

**Related concepts:**

- [Launching a Calibration Procedure](#)

PXI-4132 Calibration Procedure

Calibrate the PXI-4132 using Calibration Executive.

**Calibration Executive Procedure Features**

Verify Only ✓	Verify & Adjust ✓	Manual Mode ✓	Optional Adjust ✗
---------------	-------------------	---------------	-------------------

## Approximate Test Time

35 minutes

## Test Equipment

The following table lists the test equipment required for calibrating the PXI-4132.

**Table 312.** Test equipment for calibrating the PXI-4132

Instrument	Recommended Model	Parameter Measured	Requirements
DMM	Keysight 3458A (using at least 7.5 digits)	All Parameters	Voltage: better than $\pm 50$ ppm accuracy and better than 500 nV resolution; Current: better than $\pm 75$ ppm accuracy and better than 5 pA resolution
External Resistive Load	IET Labs HPRS-F-6-1	Load Regulation	Power resistor decade box with a range of 10 $\Omega$ to 900 k $\Omega$ and a tolerance of $\pm 10\%$ , >1 W
Two 50 $\Omega$ Resistors	Vishay PTF5650R000BZEK	Remote Sense Output	0.1% tolerance, 1/8 W
1 k $\Omega$ resistor	Vishay PTF651K0000BYBF	Remote Sense Output	0.1% tolerance, 1/8 W
Chassis	PXI-1042,PXI-1042Q	All Parameters	—

## Test Conditions

The following setup and environmental conditions are required to ensure the PXI-4132 meets published specifications.

- Keep connections to the device as short as possible. Long cables and wires act as antennas, picking up extra noise that can affect measurements.
- Verify that all connections, including front panel connections, are secure.

- Ensure that the PXI chassis fan speed is set to HIGH, that the fan filters are clean, and that the empty slots contain filler panels.
- Keep relative humidity between 10 and 70%, non-condensing.
- Allow a warm-up time of at least 30 minutes after the NI-DCPower driver is loaded. Unless manually disabled, the NI-DCPower driver automatically loads with the operating system and enables the device. The warm-up time ensures that the measurement circuitry of the PXI-4132 is at a stable operating temperature.
- Perform all measurements with the niDCPower Auto Zero property/attribute set to **On** and measurement aperture set to 1 PLC.
- Perform all measurements using Local Sense unless otherwise noted.
- Use shielded copper wire for all cable connections to the device. Use twisted-pair wire to eliminate noise and thermal offsets.
- Plug the chassis and the instrument standard into the same power strip to avoid ground loops.
- The lower magnitude DC Current functions on some DMMs are typically specified due to the increased influence of parasitics. If your DMM is typically specified (usually denoted by asterisk in specifications) for the range needed, ensure your DMM is sufficiently calibrated by a traceable, accredited laboratory to maintain traceability for this parameter.
- Follow the manufacturers' specific usage requirements of the DMM that affect the accuracy of the function used. Not following the manufacturers' requirements results in a worse Test Uncertainty Ratio (TUR). For the Keysight 3458A, refer to Considerations for the Keysight 3458A Digital Multimeter.

## Device Setup

1. Install the PXI-4132 in the PXI chassis according to the instructions in the ***NI DC Power Supplies and SMUs Getting Started Guide***.
2. Configure the hardware using Measurement & Automation Explorer (MAX).
3. Launch the Calibration Executive procedure and complete the setup wizard.



**Note** If the PXI-4132 module fails after calibration, return it to NI for repair or replacement. In the PXI-4132 calibration report, the Low and High Limit columns list the error limits and the Reading column lists the actual Test Point error/accuracy.

## Test Limit Equations

The following test limits are derived from the published specifications.

**Table 225.** PXIe-4132 Test Limit Equations

Equation Type	Equation
Voltage Programming Accuracy, Voltage Measurement Accuracy, Current Programming Accuracy and Current Measurement Accuracy	$\text{TestLimits} = \text{TestValue} \pm [\text{abs}(\text{TestValue}) * \% \text{ of reading} + \text{offset}]$
Voltage Load Regulation	0.5 mV per mA of output load using Local Sense
Current Load Regulation	0.01% of range per volt of output change
Remote Sense	Add 0.5% of HI lead drop to voltage accuracy specification

### Related concepts:

- [Considerations for the Keysight 3458A Digital Multimeter](#)
- [Launching a Calibration Procedure](#)

### Considerations for the Keysight 3458A Digital Multimeter

Follow the manufacturer's specific usage requirements for the Keysight 3458A DMM to ensure the accuracies of the measurements are sufficient for the calibration procedure. Refer to the Keysight documentation for more details.

Calibration Executive manages many of the Keysight 3458A measurement settings automatically, however you must check the following conditions manually prior to using the device.

- Autocal must be performed every 24 hours and if the internal temperature of the DMM changes more than 1 °C from the internal temperature of last Autocal.
- The internal temperature must be within  $\pm 5$  °C of last external calibration temperature ( $T_{\text{cal}}$ ).

The following tables list various temperatures, their requirements, and the SCPI commands you can use to query their values. Use the VISA Interactive Control tool

included in NI MAX to query using the SCPI commands.

**Table 226.** SCPI commands to query Keysight 3458A internal and Autocal temperatures

Definition	Notes	SCPI Command	Requirement
Internal instrument temperature	Dynamic, Immediate	TEMP?	—
Autocal	—, approximately 18 minutes	ACAL ALL	—

**Table 227.** SCPI commands to query Keysight 3458A  $T_{cal}$  temperatures

Definition	Notes	SCPI Command	Requirement
'Cal 0 temperature'	Fixed at time of adjust	CAL? 58	within $\pm 5$ °C of TEMP?
'Cal 10 temp' or 10 VDC $T_{cal}$ temperature	Fixed at time of adjust	CAL? 59	within $\pm 5$ °C of TEMP?
'Cal 10k temp' or 10 k $\Omega$ $T_{cal}$ temperature	Fixed at time of adjust	CAL? 60	within $\pm 5$ °C of TEMP?

**Table 228.** SCPI commands to query Keysight 3458A ACAL temperatures

Definition	Notes	SCPI Command	Requirement
'ACAL DCV temperature'	Changes after ACAL cmd	CAL? 175	within $\pm 1$ °C of TEMP?
'ACAL OHM temperature'	Changes after ACAL cmd	CAL? 176	within $\pm 1$ °C of TEMP?
'ACAL ACV temperature'	Changes after ACAL cmd	CAL? 177	within $\pm 1$ °C of TEMP?

## PXIe-4135 and PXIe-4135 (40W) Calibration Procedure

Calibrate the PXIe-4135 or PXIe-4135 (40W) using Calibration Executive.



**Hazardous Voltage** The PXIe-4135 and PXIe-4135 (40W) are capable of generating voltages that can be hazardous to users ( $\pm 200$  VDC). It is the responsibility of the system designer, integrator, installer, maintenance personnel, and service personnel to make sure that the module is used safely.



In this procedure, PXIe-4135 refers to the PXIe-4135 (20W). This referencing is consistent with Measurement & Automation Explorer (MAX), where MAX shows NI PXIe-4135 (40W) for the PXIe-4135 (40W) and NI PXIe-4135 for the PXIe-4135 (20W).

## Calibration Executive Procedure Features

Verify only ✓	Verify & Adjust ✓	Manual Mode ✓	Optional Adjust ✗
---------------	-------------------	---------------	-------------------

## Approximate Test Time

<b>Verify Only</b>	<b>Verify &amp; Adjust</b>
20 minutes	40 minutes

## Test Equipment

The following table lists the test instruments required for calibrating the PXIe-4135 or PXIe-4135 (40W) device.

**Table 312.** Test equipment for calibrating the PXIe-4135 or PXIe-4135 (40W)

Instrument	Recommended Model	Minimum Requirements
Digital Multimeter	Agilent 3458A	Voltage: < ±9 ppm accuracy and <100 nV resolution. Current: < ±25 ppm accuracy and <10 pA resolution.
100 MΩ Current Shunt	IET Labs SRL-100M/ Pom5219	<10 ppm accuracy, <5 ppm/°C tempco.
1 MΩ Current Shunt	IET Labs SRL-1M/1Triax	<4 ppm accuracy, <0.2 ppm/°C tempco.
1 Ω Current Shunt	Ohm Labs CS-1	<65 ppm accuracy, <5 ppm/°C tempco.
HI Sense Verification Assembly	143229A-01	—
LO Sense Verification Assembly	143230A-01	—
Output Shorting Assembly	144574A-01	—

Instrument	Recommended Model	Minimum Requirements
Triax Cable (x2)	—	—
Triax-to-Banana Cable (x2)	—	—
PXI Express Chassis	PXIe-1062Q, PXIe-1075	Any NI PXI Express chassis meets requirements.
PXIe-4135 SMU Connector Kit	784484-01	—

## Test Conditions

The following setup and environmental conditions are required to ensure the PXIe-4135 or PXIe-4135 (40W) meets published specifications.

- Ensure that the safety interlock terminal is open during verification procedures unless specifically required. Ensure proper operator safety procedures when using the PXIe-4135 or PXIe-4135 (40W) with the interlock closed.
- Keep connections to the device as short as possible. Long cables and wires act as antennas, picking up extra noise that can affect measurements.
- Verify that all connections, including front panel connections and screws, are secure.
- Ensure that the PXI Express chassis fan speed is set to HIGH, that the fan filters are clean, and that the empty slots contain slot blockers and filler panels. For more information, refer to the Maintain Forced-Air Cooling Note to Users document available at [ni.com/docs](http://ni.com/docs).
- Allow a warm-up time of at least 30 minutes after the chassis is powered on and NI-DCPower is loaded and recognizes the device. The warm-up time ensures that the device and test instrumentation are at a stable operating temperature.
- Use low noise triax cabling for all HI and HI Sense connections. For LO and LO Sense connections, use shielded twisted pair copper wire for all cable connections to the device.
- To ensure the system has had adequate time to settle, wait one second after requesting a new current or voltage or after changing a load before taking a measurement.
- When taking measurements, configure the following aperture time-related settings:
  - Set the **niDCPower Aperture Time** property or

- NIDCPOWER\_ATTR\_APERTURE\_TIME attribute to 2 power-line cycles (PLCs) on the device.
- Set the **niDCPower Aperture Time Units** property or NIDCPOWER\_ATTR\_APERTURE\_TIME\_UNITS to power line cycles.
  - Set the **niDCPower Configure Power Line Frequency** property or the NIDCPOWER\_ATTR\_POWER\_LINE\_FREQUENCY attribute to either 50 or 60 depending on the frequency of the AC power line in your location.
- Do not use the NI-DCPower Soft Front Panel (SFP) to request test points for any adjustment functions because you cannot set aperture time using the SFP.
  - Ensure that properties or attributes for the device that are not specified in calibration procedures are set to their default values.
  - When taking measurements, configure any specified digital multimeters (DMMs) with the best available ranges and measurement settings for each specified test point.
  - Keep the relative humidity between 10% and 70%, noncondensing.
  - (Verification procedures) Maintain an ambient temperature of  $23\text{ }^{\circ}\text{C} \pm 5\text{ }^{\circ}\text{C}$ . Maintain an internal device temperature range of  $T_{\text{cal}} \pm 1\text{ }^{\circ}\text{C}$ .
  - (Adjustment procedures) Maintain an ambient temperature of  $23\text{ }^{\circ}\text{C} \pm 1\text{ }^{\circ}\text{C}$ . The PXIe-4135 or PXIe-4135 (40W) internal temperature is greater than the ambient temperature.

## Considerations for Testing at High Voltage

The following conditions help ensure that the PXIe-4135 or PXIe-4135 (40W) module can be used safely at high voltage.

- Operate the PXIe-4135 or PXIe-4135 (40W) following safety regulatory standards for testing at  $\pm 200\text{ VDC}$  sourcing up to 1 mA of current.
- Use shrouded connectors and safety enclosures for all high voltage test points.
- Ensure that the safety interlock terminal is closed for test points in the 200 V range during the Verify Voltage Measurement and Output procedure. For more information about the safety interlock terminal, visit [ni.com/info](http://ni.com/info) and enter the Info Code [ni.com/docs](http://ni.com/docs).

## Safety Interlock

The PXIe-4135 or PXIe-4135 (40W) includes a safety interlock circuit that places the

outputs of the SMU in a safe state, regardless of the programmed state of the device. When you are using the PXIe-4135 to output voltages >40 V, it is recommended that you use an enclosure to cover the outputs, components, and conductors. Relays should be installed in the door(s) of the enclosure so that the safety interlock circuit is complete only when the doors are closed. This ensures that if the doors are open to access the module, its high voltage capabilities are temporarily disabled until the doors are closed again. For more information about the safety interlock terminal, visit [ni.com/info](http://ni.com/info) and enter the Info Code `exg3kh` to view the support document ***Safety Interlock***.

## Device Setup

1. Install the PXIe-4135 or PXIe-4135 (40W) in the PXI Express chassis according to the instructions in the PXIe-4135 Getting Started Guide.
2. Determine which version of the device you have by locating the device name in MAX or on the front panel of the device.
  - In MAX, the PXIe-4135 (40W) is named NI PXIe-4135 (40W) and the PXIe-4135 (20W) is named NI PXIe-4135.
  - On the front panel, the PXIe-4135 (40W) is named PXIe-4135 40W System SMU, and the PXIe-4135 (20W) is named PXIe-4135 Precision System SMU.
3. Configure the hardware using Measurement & Automation Explorer (MAX).
4. Launch the Calibration Executive procedure, and complete the setup wizard.



**Note** If the PXIe-4135 or PXIe-4135 (40W) module fails after calibration, return it to NI for repair or replacement.

## Test Limit Equations

The following test limits are derived from the published specifications.

**Table 312.** PXIe-4135/PXIe-4135 (40W) Test Limit Equations

Equation Type	Equation
Voltage Measurement and Output	Test Limits = TestValue $\pm$ ( Test Point  * % of Voltage + Offset)
Voltage Remote Sense	Test Limits = TestValue $\pm$ (Remote Sense Error)

Equation Type	Equation
	<ul style="list-style-type: none"> <li>• where Remote Sense Error = <math> V1-V2 </math></li> <li>• V1 and V2 are the taken voltage measurements using the PXIe-4135 or PXIe-4135 (40W) with different connections</li> </ul>
Current Measurement and Output	<p>Range: 10 nA to 1 <math>\mu</math>A</p> <ul style="list-style-type: none"> <li>• Current Measurement Test Limits = DMM Measured Current <math>\pm</math> (<math> </math>DMM Measured Current<math> </math> * % of Current + Offset)</li> </ul> <p>Range: 100 <math>\mu</math>A to 100 mA</p> <ul style="list-style-type: none"> <li>• Current Measurement Test Limits = Test Point <math>\pm</math> (<math> </math>Test Point<math> </math> * % of Current + Offset)</li> </ul> <p>Range: 1 A and 3 A</p> <ul style="list-style-type: none"> <li>• Current Measurement Test Limits = Test Point <math>\pm</math> (<math> </math>Test Point<math> </math> * % of Current + Offset)</li> </ul>
Current Offset	<p>Current Offset Measurement Test Limits = Test Point <math>\pm</math> (<math> </math>Test Point<math> </math> * % of Current + Offset)</p> <p>Current Offset Null Measurement Test Limits = Test Point <math>\pm</math> (<math> </math>Test Point<math> </math> * % of Current + Offset)</p>



**Note** Current Offset Null Accuracy specifications are typical for Revision E and earlier of the PXIe-4135.

## PXIe-4136/4137 and PXIe-4137 (40W) Calibration Procedure

Calibrate the PXIe-4136/4137 or PXIe-4137 (40W) using Calibration Executive.

In this procedure, PXIe-4137 refers to the PXIe-4137 (20W). This referencing is consistent with Measurement & Automation Explorer (MAX), where MAX shows NI

PXIe-4137 (40W) for the PXIe-4137 (40W) and NI PXIe-4137 for the PXIe-4137 (20W).

## Calibration Executive Procedure Features

Verify Only ✓	Verify & Adjust ✓	Manual Mode ✓	Optional Adjust ⓧ
---------------	-------------------	---------------	-------------------

## Approximate Test Time

Verify Only	Verify & Adjust
15 minutes	40 minutes



**Hazardous Voltage** The PXIe-4136/4137 and PXIe-4137 (40W) are capable of generating voltages that can be hazardous to users ( $\pm 200$  VDC). It is the responsibility of the system designer, integrator, installer, maintenance personnel, and service personnel to make sure that the module is used safely.

## Test Equipment

The following table lists the test instruments required for calibrating the PXIe-4136/4137 or PXIe-4137 (40W) devices.

**Table 312.** Test equipment for calibrating the PXIe-4136/4137 or PXIe-4137 (40W)

Instrument	Recommended Model	Minimum Requirements
Digital Multimeter	Agilent 3458A	Voltage: $< \pm 9$ ppm accuracy and $< 100$ nV resolution. Current: $< \pm 25$ ppm accuracy and $< 10$ pA resolution.
1 M $\Omega$ Current Shunt	IET Labs SRL-1M/ 1Triax	SRL Series Resistance Standard, $< 4$ ppm accuracy, $< 0.2$ ppm/ $^{\circ}\text{C}$ tempco.
1 $\Omega$ Current Shunt	Ohm Labs CS-1	CS1 Precision Shunt, $< 65$ ppm accuracy, $< 5$ ppm/ $^{\circ}\text{C}$ tempco.
3 k $\Omega$ Resistor	Vishay PTF563K0000BYEB	0.1% 250 mW

## Test Conditions

The following setup and environmental conditions are required to ensure the PXIe-4136/4137 or PXIe-4137 (40W) meets published specifications.

- Keep connections to the device as short as possible. Long cables and wires act as antennas, picking up extra noise that can affect measurements.
- Ensure that the PXI Express chassis fan speed is set to HIGH, that the fan filters are clean, and that the empty slots contain slot blockers and filler panels. For more information, refer to the ***Maintain Forced-Air Cooling Note to Users*** document available at [ni.com/docs](http://ni.com/docs).
- Allow a warm-up time of at least 30 minutes after the chassis is powered on and NI-DCPower is loaded and recognizes the PXIe-4136/4137 or PXIe-4137 (40W). The warm-up time ensures that the PXIe-4136/4137 or PXIe-4137 (40W) and test instrumentation are at a stable operating temperature.
- Use shielded copper wire for all cable connections to the device. Use twisted-pair wire to eliminate noise and thermal offsets.
- Keep the relative humidity between 10% and 70%, noncondensing.
- (Verification procedures) Maintain an ambient temperature of  $23\text{ }^{\circ}\text{C} \pm 5\text{ }^{\circ}\text{C}$ . Maintain an internal device temperature range of  $T_{\text{cal}} \pm 1\text{ }^{\circ}\text{C}$ .
- (Adjustment procedures) Maintain an ambient temperature of  $23\text{ }^{\circ}\text{C} \pm 1\text{ }^{\circ}\text{C}$ . The PXIe-4136/4137 or PXIe-4137 (40W) internal temperature is greater than the ambient temperature.

## Considerations for Testing at High Voltage

The following conditions help ensure that the PXIe-4136/4137 or PXIe-4137 (40W) module can be used safely at high voltage.

- Operate the PXIe-4136/4137 or PXIe-4137 (40W) following safety regulatory standards for testing at  $\pm 200\text{ VDC}$  sourcing up to 1 mA of current.
- Use shrouded connectors and safety enclosures for all high voltage test points.
- Ensure that the safety interlock terminal is closed for test points in the 200 V range during the Verify Voltage Measurement and Output procedure. For more information about the safety interlock terminal, visit [ni.com/info](http://ni.com/info) and enter the Info Code `exg3kh` to view the support document Safety Interlock.
- To ensure safe operation of the PXIe-4136/4137 or PXIe-4137 (40W), periodically

test the safety interlock for proper functionality. The recommended test interval is at least once per day of continuous usage. For more information on testing the safety interlock circuit, refer to the **NI PXIe-4136/4137 Getting Started Guide**, available at [ni.com/docs](http://ni.com/docs).

## Safety Interlock

The PXIe-4136/4137 or PXIe-4137 (40W) includes a safety interlock circuit that places the outputs of the SMU in a safe state, regardless of the programmed state of the device. When you are using the PXIe-4136/4137 or PXIe-4137 (40W) to output voltages >40 V, it is recommended that you use an enclosure to cover the outputs, components, and conductors. Relays should be installed in the door(s) of the enclosure so that the safety interlock circuit is complete only when the doors are closed. This ensures that if the doors are open to access the module, its high voltage capabilities are temporarily disabled until the doors are closed again. For more information about the safety interlock terminal, visit [ni.com/info](http://ni.com/info) and enter the Info Code `exg3kh` to view the support document **Safety Interlock**.

## Device Setup

1. Install the PXIe-4136/4137 or PXIe-4137 (40W) in the PXI Express chassis according to the instructions in the NI PXIe-4136/4137 Getting Started Guide.
2. Determine which version of the device you have by locating the device name in MAX or on the front panel of the device.
  - In MAX, the PXIe-4137 (40W) is named NI PXIe-4137 (40W) and the PXIe-4137 (20W) is named NI PXIe-4137.
  - On the front panel, the PXIe-4137 (40W) is named PXIe-4137 40W System SMU, and the PXIe-4137 (20W) is named PXIe-4137 Precision System SMU.
3. Configure the hardware using Measurement & Automation Explorer (MAX).
4. Launch the Calibration Executive procedure, and complete the setup wizard.



**Note** If the PXIe-4136/4137 or PXIe-4137 (40W) module fails after calibration, return it to NI for repair or replacement.



## Test Limit Equations

The following test limits are derived from the published specifications.

**Table 232.** PXIe-4136/4137 and PXIe-4137 (40W) Test Limit Equations

Equation Type	Equation
Voltage Measurement and Output	Test Limits = TestValue $\pm$ ( Test Point  * % of Voltage + Offset)
Voltage Remote Sense	Test Limits = TestValue $\pm$ (Remote Sense Error) <ul style="list-style-type: none"> <li>• where Remote Sense Error = <math> V1-V2 </math></li> <li>• V1 and V2 are the taken voltage measurements using the PXIe-4136/4137 or PXIe-4137 (40W) with different connections</li> </ul>
Current Measurement and Output	Range: 1 $\mu$ A to 10 $\mu$ A <ul style="list-style-type: none"> <li>• Current Measurement Test Limits = DMM Measured Current <math>\pm</math> ( DMM Measured Current  * % of Current + Offset)</li> </ul> Range: 100 $\mu$ A to 100 mA <ul style="list-style-type: none"> <li>• Current Measurement Test Limits = Test Point <math>\pm</math> ( Test Point  * % of Current + Offset)</li> </ul> Range: 1 A and 3 A <ul style="list-style-type: none"> <li>• Current Measurement Test Limits = Test Point <math>\pm</math> ( Test Point  * % of Current + Offset)</li> </ul>

## PXIe-4138/4139 and PXIe-4139 (40W) Calibration Procedure

Calibrate the PXIe-4138/4139 or PXIe-4139 (40W) using Calibration Executive.

In this procedure, PXIe-4139 refers to the PXIe-4139 (20W). This referencing is consistent with Measurement & Automation Explorer (MAX), where MAX shows NI PXIe-4139 (40W) for the PXIe-4139 (40W) and NI PXIe-4139 for the PXIe-4139 (20W).

## Calibration Executive Procedure Features

Verify Only ✓	Verify & Adjust ✓	Manual Mode ✓	Optional Adjust ✗
---------------	-------------------	---------------	-------------------

## Approximate Test Time

Verify Only	Verify & Adjust
8 minutes	24 minutes

## Test Equipment

The following table lists the test instruments required for calibrating the PXIe-4138/4139 and PXIe-4139 (40W) devices.

**Table 312.** Test equipment for calibrating the PXIe-4138/4139 and PXIe-4139 (40W)

Instrument	Recommended Model	Minimum Requirements
Digital Multimeter	Agilent 3458A	Voltage: < $\pm 9$ ppm accuracy and < 100 nV resolution Current: < $\pm 25$ ppm accuracy and < 10 pA resolution
1 M $\Omega$ Current Shunt	IET Labs SRL-1M/1Triax	SRL Series Resistance Standard, < 4 ppm accuracy, < 0.2 ppm/ $^{\circ}$ C tempco
1 $\Omega$ Current Shunt	Ohm Labs CS-1	Cs1 Precision Shunt, < 65 ppm accuracy, < 5 ppm/ $^{\circ}$ C tempco
333 m $\Omega$ Current Shunt	Ohm Labs CS-3	CS-3-1 Precision Shunt, < 120 ppm accuracy, < 5 ppm/ $^{\circ}$ C tempco This shunt is only available on request; use the following format: CS-3-1 = 3A, 1V, 0.333 Ohm
3 k $\Omega$ Resistor	Vishay PTF563K0000BYEB	3 k $\Omega$ 0.1% metal film resistors, through-hole resistors, 250 mW, 10 ppm
Triax Adapter SA-413T	NI P/N 784000-01	Triax adapter used for connecting a triax cable from the PXIe-4138/4139 or PXIe-4139 (40W) to the 1 M $\Omega$ current shunt

Instrument	Recommended Model	Minimum Requirements
Low thermal test leads	Fluke 5440	Shielded, twisted-pair copper cables with copper or gold-plated copper banana plugs
PXI Express Chassis	PXIe-1065	If this chassis is unavailable, use another PXI Express chassis with HIGH fan speed option

## Test Conditions

The following setup and environmental conditions are required to ensure the PXIe-4138/4139 and PXIe-4139 (40W) meet published specifications.

- Keep connections to the device as short as possible. Long cables and wires act as antennas, picking up extra noise that can affect measurements.
- Verify that all connections to the device, including front panel connections and screws, are secure.
- Use shielded copper wire for all cable connections to the device. Use twisted-pair wire to eliminate noise and thermal offsets.
- Ensure that the PXI Express chassis fan speed is set to HIGH, that the fan filters are clean, and that the empty slots contain slot blockers and filler panels. For more information, refer to the Maintain Forced-Air Cooling Note to Users document available at [ni.com/docs](http://ni.com/docs).
- Keep the relative humidity between 10% and 70%, noncondensing.
- Allow a warm-up time of at least 30 minutes after the chassis is powered on and niDCPower is loaded and recognizes the PXIe-4138/4139 or PXIe-4139 (40W). Allow adequate warm-up time for all other instruments and equipment according to the manufacturer instructions. The warm-up time ensures that the PXIe-4138/4139 or PXIe-4139 (40W) and test instrumentation are at a stable operating temperature.
- When making measurements, configure any specified digital multimeters (DMMs) with the best available levels and limits for each specified test point.
- (Verification procedures) Maintain an ambient temperature of  $23\text{ }^{\circ}\text{C} \pm 5\text{ }^{\circ}\text{C}$ . Maintain an internal device temperature range of  $T_{\text{cal}} \pm 5\text{ }^{\circ}\text{C}$ .1.
- (Adjustment procedures) Maintain an ambient temperature of  $23\text{ }^{\circ}\text{C} \pm 1\text{ }^{\circ}\text{C}$ . The PXIe-4138/4139 or PXIe-4139 (40W) internal temperature will be greater than the ambient temperature.

## Device Setup

1. Install the PXIe-4138/4139 or PXIe-4139 (40W) in the PXI Express chassis according to the instructions in the NI DC Power Supplies and SMUs Getting Started Guide.
2. Determine which version of the device you have by locating the device name in MAX or on the front panel of the device.
  - In MAX, the PXIe-4139 (40W) is named NI PXIe-4139 (40W) and the PXIe-4139 (20W) is named NI PXIe-4139.
  - On the front panel, the PXIe-4139 (40W) is named PXIe-4139 40W System SMU and the PXIe-4139 (20W) is named NI PXIe-4139 Precision System SMU.
3. Configure the device in MAX.
4. Launch the Calibration Executive procedure and complete the setup wizard.



**Note** If the PXI-4138/4139 or PXIe-4139 (40W) module fails after calibration, return it to NI for repair or replacement.

## Test Limit Equations

The following test limits are derived from the published specifications.

**Table 234.** PXIe-4138/4139 and PXIe-4139 (40W) Test Limit Equations

Equation	Equation Type
Voltage Measurement and Output	Test Limits = TestValue $\pm$ ( Test Point  * % of Voltage + Offset)
Voltage Remote Sense	Test Limits = TestValue $\pm$ (Remote Sense Error) <ul style="list-style-type: none"> <li>• where Remote Sense Error =  V1-V2 </li> <li>• V1 and V2 are the taken voltage measurements using the PXIe-4138/4139 or PXIe-4139 (40W) with different connections</li> </ul>
Current Measurement and Output	Range: 1 $\mu$ A to 10 $\mu$ A <ul style="list-style-type: none"> <li>• Current Measurement Test Limits = DMM Measured Current <math>\pm</math> ( DMM Measured</li> </ul>

Equation	Equation Type
	$\text{Current} \pm ( \text{Test Point}  * \% \text{ of Current} + \text{Offset})$ <p>Range: 100 <math>\mu</math>A to 100 mA</p> <ul style="list-style-type: none"> <li>Current Measurement Test Limits = Test Point <math>\pm</math> ( Test Point  * % of Current + Offset)</li> </ul> <p>Range: 1 A and 3 A</p> <ul style="list-style-type: none"> <li>Current Measurement Test Limits = Test Point <math>\pm</math> ( Test Point  * % of Current + Offset)</li> </ul>

## PXIe-4140/4141/4142/4143 Calibration Procedure

Calibrate the PXIe-4140/4141/4142/4143 using Calibration Executive.

### Calibration Executive Procedure Features

Verify Only ✓	Verify & Adjust ✓	Manual Mode ✓	Optional Adjust ✗
---------------	-------------------	---------------	-------------------

### Approximate Test Time

Verify Only	Verify & Adjust
20 minutes	40 minutes

### Equipment Characterization: Resistors

### Test Equipment

The following table lists the test instruments required for calibrating the PXIe-4140/4141/4142/4143 devices.

**Table 312.** Test equipment for calibrating the PXIe-4140/4141/4142/4143

Instrument	Recommended Model	Specification	Value
DMM	Agilent 3458A	All Parameters	Voltage: better than $\pm 26$ ppm accuracy and better than $1 \mu\text{V}$ resolution
Cabling and Resistor Box*	Contact NI and reference NI P/N 538612B-00	Characterization	—
Screw Terminal Connector Kit for PXIe-414x SMUs†	Contact NI and reference NI P/N 781974-01	Characterization	—
50 $\Omega$ Resistor (x2)†	Vishay PTF5650R000BZEK	Remote Sense Output	0.1% tolerance, 1/8 W
10 $\Omega$ Resistor†	Vishay CMF5510R000BEEK	Current Remote Sense	0.1% tolerance, 1/4 W
100 $\Omega$ Resistor†	Vishay PTF65100R00BYEK	Current Remote Sense	0.1% tolerance, 1/4 W
1 k $\Omega$ Resistor†	Vishay PTF651K0000BYEK	Remote Sense Output	0.1% tolerance, 1/4 W
10 k $\Omega$ Resistor†	Vishay PTF6510K000BYEK	Current Remote Sense	0.1% tolerance, 1/4 W
100 k $\Omega$ Resistor†	Vishay PTF65100K00BYEK	Current Remote Sense	0.1% tolerance, 1/4 W



## Note

- \*An NI Cabling and Resistor Box (538612B-00) is recommended when calibrating this module.
- †Screw Terminal Connector Kit (781974-01) and resistors are not necessary if you use the NI Cabling and Resistor Box. If you choose instead to use individual resistors, you must closely follow the connections outlined in the PXIe-4140, PXIe-4141, PXIe-4142 or

PXIe-4143 Calibration Procedure while running the procedure.



**Note** To take measurements in the 10  $\mu\text{A}$  range with the Agilent 3458A, you must send your device to the Agilent Primary Standards Lab for a special calibration to verify the 10  $\mu\text{A}$ , 1  $\mu\text{A}$ , and 100 nA ranges.

## Test Conditions

The following setup and environmental conditions are required to ensure the PXIe-4140/4141/4142/4143 devices meet published specifications.

- Keep connections to the device as short as possible. Long cables and wires act as antennas, picking up extra noise that can affect measurements.
- Verify that all connections to the device, including front panel connections, are secure.
- Use shielded copper wire for all cable connections to the device. Use twisted-pair wire to eliminate noise and thermal offsets.
- Ensure that the PXI Express chassis fan speed is set to HIGH, that the fan filters are clean, and that the empty slots contain filler panels. For more information, refer to the ***Maintain Forced-Air Cooling Note to Users*** document available at [ni.com/docs](http://ni.com/docs).
- Keep the relative humidity between 10% and 70%, noncondensing.
- Allow a warm-up time of at least 30 minutes after NI-DCPower is loaded. Unless manually disabled, the NI-DCPower driver automatically loads with the operating system and enables the device.
- Allow the Agilent 3458A to warm up for at least 4 hours.
- (Verification procedures) Maintain an ambient temperature of  $23\text{ }^{\circ}\text{C} \pm 5\text{ }^{\circ}\text{C}$ . Maintain an internal device temperature range of  $T_{\text{cal}} \pm 5\text{ }^{\circ}\text{C}$ .  $T_{\text{cal}}$  is the internal device temperature recorded by the DUT at the completion of the last self-calibration. Use the niDCPower Get Self Cal Last Temp VI to query  $T_{\text{cal}}$  from the DUT.
- (Adjustment procedures) Maintain an ambient temperature of  $23\text{ }^{\circ}\text{C} \pm 1\text{ }^{\circ}\text{C}$ . The NI 4141 internal temperature will be greater than the ambient temperature.
- Plug the chassis and the instrument standard into the same power strip to avoid

ground loops.

## Device Setup

1. Install the PXIe-4140/4141/4142/4143 in the PXI Express chassis according to the instructions in the NI DC Power Supplies and SMUs Getting Started Guide.
2. Configure the hardware using Measurement & Automation Explorer (MAX).
3. Launch the Calibration Executive procedure. Calibration Executive guides you through the required connections.



**Note** The resistors used in this procedure must be characterized prior to executing the procedure. Follow the instructions in Resistor Characterization for performing this characterization.

## Test Limit Equations

The following test limits are derived from the published specifications.

**Table 236.** PXIe-4140 Test Limit Equations

Equation Type	Equation
Voltage Output and Measurement Verification	$\text{TestLimits} = \text{TestLimit} \pm \text{MeasurementTestLimit}$ <ul style="list-style-type: none"> <li>• <math>\text{MeasurementTestLimit} = \text{abs}(\text{TestPoint} * \text{Scale}) + \text{Offset}</math></li> </ul>
Current Output and Measurement Verification	$\text{TestLimits} = \text{TestLimit} \pm \text{Measurement TestLimit}$ <ul style="list-style-type: none"> <li>• <math>\text{MeasurementTestLimit} = \text{abs}(\text{TestPoint} * \text{Scale}) + \text{Offset}</math></li> </ul>
Voltage Remote Sense Accuracy Verification	$\text{LoadVoltageLimit} = 10 \text{ V} \pm (\text{V1} + \text{LOLeadDrop} * 0.001)$ <ul style="list-style-type: none"> <li>• <math>\text{V1} = 0.015 \text{ V}</math></li> <li>• LOLeadDrop is measured with DMM Measurement 1</li> </ul>



Equation Type	Equation
Current Remote Sense Accuracy Verification	$\text{AccuracyLimit} = \text{TestPoint} \pm [\text{BaseLimit} + (\text{TotalLeadDrop} * x\% \text{ of I Range})]$ <ul style="list-style-type: none"> <li>• <math>\text{TotalLeadDrop} = \text{LeadDrop 1} + \text{LeadDrop 2}</math> <ul style="list-style-type: none"> <li>◦ where LeadDrop 1 and 2 are the values measured by the DMM on all of the resistors <ul style="list-style-type: none"> <li>▪ <math>x = 0.02\%</math></li> </ul> </li> </ul> </li> </ul>

Table 237. PXIe-4141 Test Limit Equations

Equation Type	Equation
Voltage Output and Measurement Verification	$\text{TestLimits} = \text{TestLimit} \pm \text{MeasurementTestLimit}$ <ul style="list-style-type: none"> <li>• <math>\text{MeasurementTestLimit} = \text{abs}(\text{TestPoint} * \text{Scale}) + \text{Offset}</math></li> </ul>
Current Output and Measurement Verification	$\text{TestLimits} = \text{TestLimit} \pm \text{Measurement TestLimit}$ <ul style="list-style-type: none"> <li>• <math>\text{MeasurementTestLimit} = \text{abs}(\text{TestPoint} * \text{Scale}) + \text{Offset}</math></li> </ul>
Voltage Remote Sense Accuracy Verification	$\text{LoadVoltageLimit} = 10 \text{ V} \pm (V1 + \text{LOLeadDrop} * 0.001)$ <ul style="list-style-type: none"> <li>• <math>V1 = 0.0021 \text{ V}</math></li> <li>• LOLeadDrop is measured with DMM Measurement 1</li> </ul>
Current Remote Sense Accuracy Verification	$\text{AccuracyLimit} = \text{TestPoint} \pm [\text{BaseLimit} + (\text{TotalLeadDrop} * x\% \text{ of I Range})]$ <ul style="list-style-type: none"> <li>• <math>\text{TotalLeadDrop} = \text{LeadDrop 1} + \text{LeadDrop 2}</math> <ul style="list-style-type: none"> <li>◦ where LeadDrop 1 and 2 are the values measured by the DMM on all of the resistors <ul style="list-style-type: none"> <li>▪ <math>x = 0.02\%</math></li> </ul> </li> </ul> </li> </ul>

Table 238. PXIe-4142 Test Limit Equations

Equation Type	Equation
Voltage Output and Measurement Verification	$\text{TestLimits} = \text{TestLimit} \pm \text{MeasurementTestLimit}$ <ul style="list-style-type: none"> <li>• <math>\text{MeasurementTestLimit} = \text{abs}(\text{TestPoint} * \text{Scale}) + \text{Offset}</math></li> </ul>
Current Output and Measurement Verification	$\text{TestLimits} = \text{TestLimit} \pm \text{Measurement TestLimit}$ <ul style="list-style-type: none"> <li>• <math>\text{MeasurementTestLimit} = \text{abs}(\text{TestPoint} * \text{Scale}) + \text{Offset}</math></li> </ul>
Voltage Remote Sense Accuracy Verification	$\text{LoadVoltageLimit} = 10 \text{ V} \pm (\text{V1} + \text{LOLeadDrop} * 0.001)$ <ul style="list-style-type: none"> <li>• <math>\text{V1} = 0.02 \text{ V}</math></li> <li>• LOLeadDrop is measured with DMM Measurement 1</li> </ul>
Current Remote Sense Accuracy Verification	$\text{AccuracyLimit} = \text{TestPoint} \pm [\text{BaseLimit} + (\text{TotalLeadDrop} * x\% \text{ of I Range})]$ <ul style="list-style-type: none"> <li>• <math>\text{TotalLeadDrop} = \text{LeadDrop 1} + \text{LeadDrop 2}</math> <ul style="list-style-type: none"> <li>◦ where LeadDrop 1 and 2 are the values measured by the DMM on all of the resistors <ul style="list-style-type: none"> <li>▪ <math>x = 0.03\%</math></li> </ul> </li> </ul> </li> </ul>

Table 239. PXIe-4143 Test Limit Equations

Equation Type	Equation
Voltage Output and Measurement Verification	$\text{TestLimits} = \text{TestLimit} \pm \text{MeasurementTestLimit}$ <ul style="list-style-type: none"> <li>• <math>\text{MeasurementTestLimit} = \text{abs}(\text{TestPoint} * \text{Scale}) + \text{Offset}</math></li> </ul>
Current Output and Measurement Verification	$\text{TestLimits} = \text{TestLimit} \pm \text{Measurement TestLimit}$

Equation Type	Equation
	<ul style="list-style-type: none"> <li>MeasurementTestLimit = abs(TestPoint * Scale) + Offset</li> </ul>
Voltage Remote Sense Accuracy Verification	$LoadVoltageLimit = 10\text{ V} \pm (V1 + LOLeadDrop * 0.001)$ <ul style="list-style-type: none"> <li>V1 = 0.0027 V</li> <li>LOLeadDrop is measured with DMM Measurement 1</li> </ul>
Current Remote Sense Accuracy Verification	$AccuracyLimit = TestPoint \pm [BaseLimit + (TotalLeadDrop * x\% \text{ of I Range})]$ <ul style="list-style-type: none"> <li>TotalLeadDrop = LeadDrop 1 + LeadDrop 2                             <ul style="list-style-type: none"> <li>where LeadDrop 1 and 2 are the values measured by the DMM on all of the resistors                                     <ul style="list-style-type: none"> <li>x = 0.03%</li> </ul> </li> </ul> </li> </ul>

**Related concepts:**

- [PXIe-414x Resistor Box Characterization](#)

## PXIe-4144/4145 Calibration Procedure

Calibrate the PXIe-4144/4145 devices using Calibration Executive.

### Calibration Executive Procedure Features

Verify Only ✓	Verify & Adjust ✓	Manual Mode ✓	Optional Adjust ✗
---------------	-------------------	---------------	-------------------

### Approximate Test Time

Verify Only	Verify & Adjust
10 minutes	20 minutes

## Equipment Characterization: Resistors

### Test Equipment

The following table lists the test equipment required for calibrating PXIe-4144/4145 modules.

**Table 312.** Test equipment for calibrating the PXIe-4144/4145

Instrument	Recommended Model	Specification	Requirements
DMM	Agilent 3458A	All Parameters	Voltage: better than $\pm 26$ ppm accuracy and better than $1 \mu\text{V}$ resolution
Cabling and Resistor Box*	Contact NI and reference NI P/N 538612B-00	Characterization	—
Screw Terminal Connector Kit for PXIe-414x SMUs <sup>†</sup>	Contact NI and reference NI P/N 781974-01	Characterization	—
50 $\Omega$ Resistor (x2) <sup>†</sup>	Vishay PTF5650R000BZEK	Remote Sense Accuracy Verification	0.1% tolerance, 1/8 W
500 $\Omega$ Resistor <sup>†</sup>	Vishay PTF56500R00BYEK	Remote Sense Accuracy Verification	0.1% tolerance, 1/4 – 1/8 W



### Note

- \*An NI Cabling and Resistor Box (538612B-00) is recommended when calibrating this module.
- <sup>†</sup>Screw Terminal Connector Kit (781974-01) and resistors are not necessary if you use the NI Cabling and Resistor Box. If you choose instead to use individual resistors, you must closely follow the connections outlined in the PXIe-4144 or PXIe-4145 Calibration Procedure while running the procedure.



**Note** To ensure the accuracy of measurements made in the 10  $\mu\text{A}$  range with the Agilent 3458A, send the device to the Agilent Primary Standards Lab for a special calibration to verify the 10  $\mu\text{A}$ , 1  $\mu\text{A}$ , and 100 nA ranges.

## Test Conditions

The following setup and environmental conditions are required to ensure the PXIe-4144/4145 devices meet published specifications.

- Keep connections to the devices as short as possible. Long cables and wires act as antennas, picking up extra noise that can affect measurements.
- Verify that all connections to the device, including front panel connections, are secure.
- Use shielded copper wire for all cable connections to the device. Use twisted-pair wire to eliminate noise and thermal offsets.
- Ensure that the PXI Express chassis fan speed is set to HI, that the fan filters are clean, and that the empty slots contain filler panels. For more information, refer to the ***Maintain Forced-Air Cooling Note to Users*** document available at [ni.com/docs](http://ni.com/docs).
- Keep relative humidity between 10% and 70%, noncondensing.
- Allow the device to warm up for at least 30 minutes after the NI-DCPower driver is loaded. Unless manually disabled, the NI-DCPower driver automatically loads with the operating system and enables the device.
- Allow the DMM to warm up for its recommended warm up interval.
- Set the niDCPower Aperture Time property/attribute to 2 PLCs.
- Perform self-calibration after allowing the device to warm up and before starting the verification or adjustment procedure. For example, during a full calibration, perform self-calibration before initial verification, adjustment, and re-verification.
- Use shielded copper wire for all cable connections to the device. Use twisted-pair wire to eliminate noise and thermal offsets.
- (Verification procedures) Maintain an ambient temperature of  $23\text{ }^{\circ}\text{C} \pm 5\text{ }^{\circ}\text{C}$ . Maintain an internal device temperature range of  $T_{\text{cal}} \pm 5\text{ }^{\circ}\text{C}$ .  $T_{\text{cal}}$  is the internal device temperature recorded by the DUT at the completion of the last self-calibration. Use the niDCPower Get Self Cal Last Temp VI to query  $T_{\text{cal}}$  from the DUT.
- (Adjustment procedures) Maintain an ambient temperature of  $23\text{ }^{\circ}\text{C} \pm 1\text{ }^{\circ}\text{C}$ . The NI

4144 internal temperature will be greater than the ambient temperature.

- Plug the chassis and the instrument standard into the same power strip to avoid ground loops.

## Device Setup

1. Install the PXIe-4144/4145 module in the PXI Express chassis according to the instructions in the NI DC Power Supplies and SMUs Getting Started Guide.
2. Configure the hardware using Measurement & Automation Explorer (MAX).
3. Launch the Calibration Executive procedure. Calibration Executive guides you through the required connections.



**Note** The resistors used in this procedure must be characterized prior to executing the procedure. Follow the instructions in Resistor Characterization for performing this characterization.

## Test Limit Equations

The following test limits are derived from the published specifications.

**Table 241.** PXIe-4144/4145 Test Limit Equations

Equation Type	Equation
Voltage Output and Measurement Verification	$\text{TestLimits} = \text{TestLimit} \pm \text{MeasurementTestLimit}$ <ul style="list-style-type: none"> <li>• <math>\text{MeasurementTestLimit} = \text{abs}(\text{TestPoint} * \text{Scale}) + \text{Offset}</math></li> </ul>
Current Output and Measurement Verification	$\text{TestLimits} = \text{TestLimit} \pm \text{Measurement TestLimit}$ <ul style="list-style-type: none"> <li>• <math>\text{MeasurementTestLimit} = \text{abs}(\text{TestPoint} * \text{Scale}) + \text{Offset}</math></li> </ul>
Voltage Remote Sense Accuracy Verification	$\text{Load Voltage Limit} = 5 \text{ V} \pm (0.00135 \text{ V} + \text{LO Lead Drop} * 0.001)$

**Related concepts:**

- [PXIe-414x Resistor Box Characterization](#)

## PXIe-414x Resistor Box Characterization

Complete the following resistor characterization procedures using a high-precision DMM before running the PXIe-4140/4141/4142/4143 or PXIe-4144/4145 calibration procedures.

You must use the same cable(s) used in this characterization for the Voltage and Current Remote Sense Verification tests.

These characterization instructions only use the channel 0 cable connection to make the lead resistance measurements.

Verify that the difference in lead resistance between all four channels is  $<1$  m $\Omega$ . For all measurements, configure the DMM for 4-wire resistance mode, and at least 6.5 digits of precision.



**Note** The following Current Remote Sense Characterizations are for the PXIe-4140/4141/4142/4143 devices only.

### Current Remote Sense HI/R1 Characterization

Refer to Figure 1 for connection details.

1. Connect Ch0 to the 100k resistor in the R1(HI) location as shown in Figure 1.
2. Place the LO and LO Sense DMM leads on pin 14 of the Db25 DSUB connector and place the HI and HI Sense DMM leads at appropriate lead of the R1 resistor according to Figure 1.
3. Wait one second for the DMM to settle.
4. Record the resistance to six digits of precision and enter the value in the appropriate text box on the **Verify Resistor Values** dialog box, displayed at the beginning of the PXIe-4140/4141/4142/4143 Calibration Procedure.
5. Repeat steps 1-4 for the following R1 resistance values: 10k, 1k, 100, 10.

**Figure 1. Current Remote Sense R1 Characterization**

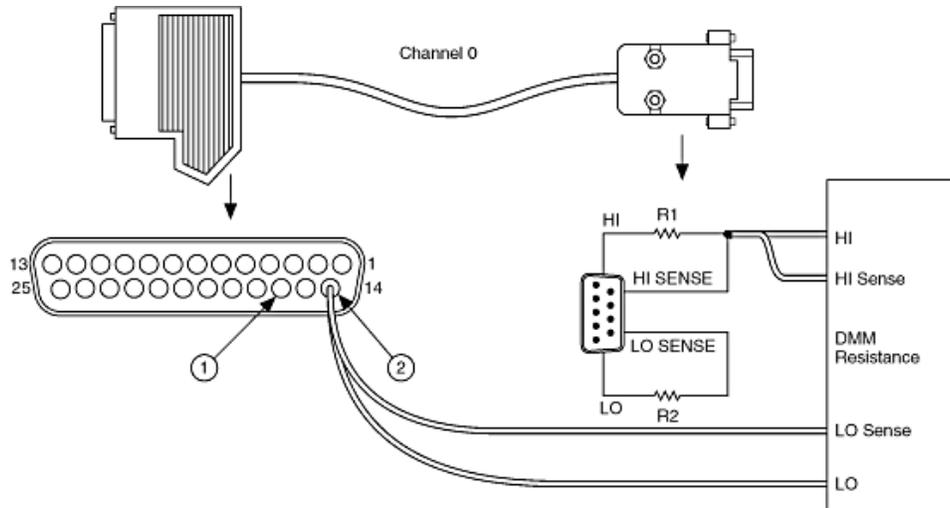

1. Ch0 Output LO (Pin 16)
2. Ch0 Output HI (Pin 14)

## Current Remote Sense LO/R2 Characterization

Refer to Figure 2 for connection details.

1. Connect Ch0 to the 100k resistor in the R2 / LO location as shown in Figure 2.
2. Place the LO and LO Sense DMM leads on pin 16 of the Db25 DSUB connector and place the HI and HI Sense DMM leads at appropriate lead of the R2 resistor according to Figure 2.
3. Wait one second for the DMM to settle.
4. Record the resistance to six digits of precision and enter the value in the appropriate text box on the **Verify Resistor Values** dialog box, displayed at the beginning of the PXIe-4140/4141/4142/4143 Calibration Procedure.
5. Repeat steps 1-4 for the following R2 resistance values: 10k, 1k, 100, 10.

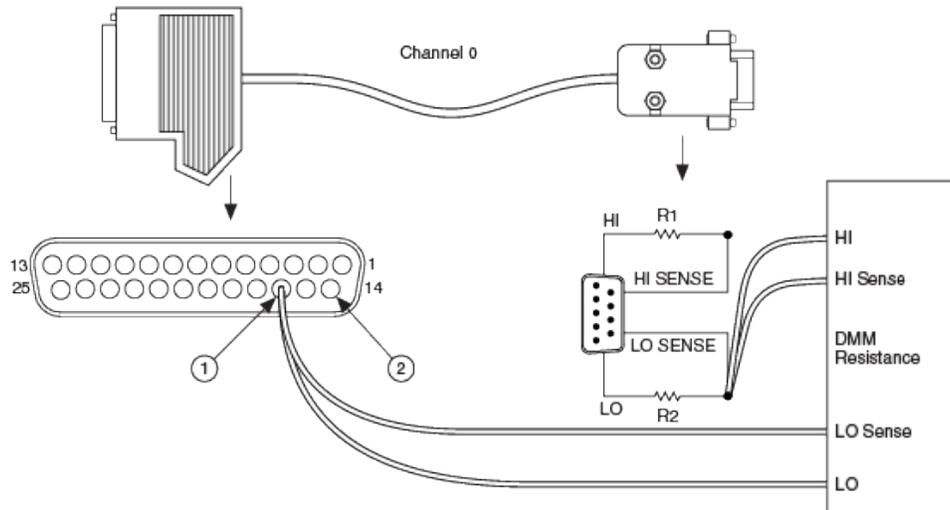

**Figure 1. Current Remote Sense LO/R2 Characterization**

1. 1 Ch0 Output LO (Pin 16)
2. Ch0 Output HI (Pin 14)

## Voltage Remote Sense Accuracy 50 $\Omega$ HI Resistor Characterization

Refer to Figure 3 for connection details.

1. Place the DMM LO and LO Sense leads on pin 14 of the Db25 DSUB connector and place the DMM HI and HI Sense leads on the appropriate resistor lead according to Figure 3.
2. Wait one second for the DMM to settle.
3. Record the resistance to six digits of precision and enter the value in the appropriate text box on the **Verify Resistor Values** dialog box, displayed at the beginning of the PXIe-4140/4141/4142/4143 and PXIe-4144/4145 Calibration Procedures.

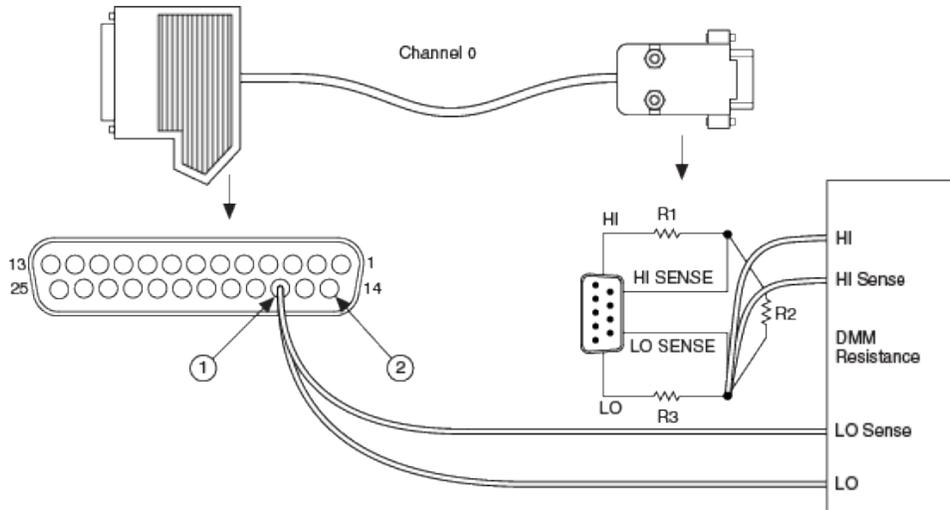

**Figure 1. Voltage Remote Sense LO/R3 Characterization**

1. Ch0 Output LO (Pin 16)
2. Ch0 Output HI (Pin 14)

## Voltage Remote Sense Accuracy 1K $\Omega$ Resistor Characterization

Refer to Figure 5 for connection details. the Voltage Remote Sense Accuracy 1K  $\Omega$  Resistor Characterization applies only to PXIe-4140/4141/4142/4143 devices.

1. Connect the DMM HI and HI Sense leads to one end of the 1k  $\Omega$  resistor and connect the DMM LO and LO Sense leads to the other end of the resistor.
2. Wait one second for the DMM to settle.
3. Record the resistance to six digits of precision and enter the value in the appropriate text box on the **Verify Resistor Values** dialog box, displayed at the beginning of the PXIe-4140/4141/4142/4143 Calibration Procedure.

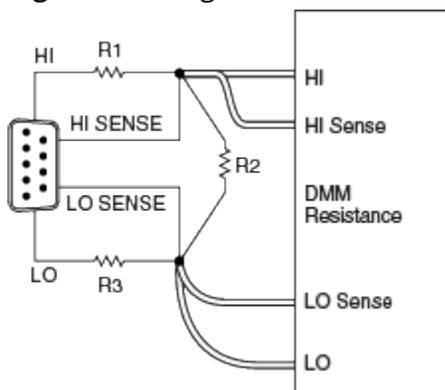
**Figure 1. Voltage Remote Sense R2/1k Resistor Characterization**

## Voltage Remote Sense Accuracy 500 $\Omega$ Resistor Characterization

Refer to Figure 6 for connection details. The Voltage Remote Sense Accuracy 500  $\Omega$  Resistor Characterization applies only to PXIe-4144/4145 devices.

1. Connect the DMM HI and HI Sense leads to one end of the 500  $\Omega$  resistor and connect the DMM LO and LO Sense leads to the other end of the resistor.
2. Wait one second for the DMM to settle.
3. Record the resistance to six digits of precision and enter the value in the appropriate text box on the **Verify Resistor Values** dialog box, displayed at the beginning of the PXIe-4144/4145 Calibration Procedure.

**Figure 1.** Voltage Remote Sense R2/500 Resistor Characterization

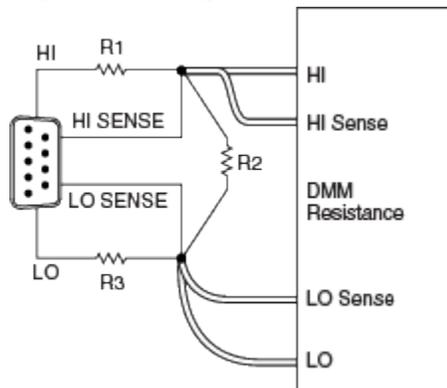

### Related concepts:

- [PXIe-4140/4141/4142/4143 Calibration Procedure](#)

## PXIe-4147 Calibration Procedure

Calibrate the PXIe-4147 using Calibration Executive.

### Calibration Executive Procedure Features

Verify Only ✓	Adjust Only ✓	Verify & Adjust ✓	Manual Mode ✓	Optional Adjust ✗
---------------	---------------	-------------------	---------------	-------------------

## Approximate Test Time

Run Options	Warmup	As-found Verify Steps	Adjust Steps	As-left Verify Steps	Total
Verify Only	30 minutes	35 minutes	—	—	1 hour 5 minutes
Adjust Only	30 minutes	—	10 minutes	—	40 minutes
Verify & Adjust	30 minutes	35 minutes	15 minutes	35 minutes	2 hours

## Test Equipment

The following table lists the test equipment required for calibrating the PXIe-4147.

**Table 312.** Test equipment for calibrating the PXIe-4147

Instrument	Recommended Model	Where Used	Requirements
DMM	Keysight 3458A	Voltage Measurement and Output Accuracy, Remote Sense Voltage Offset Accuracy, Current Measurement and Output Accuracy	—
1 M $\Omega$ current shunt	IET Labs SRL-1M/1-Triax	1 $\mu$ A and 10 $\mu$ A Current Measurement and Output	—
333 m $\Omega$ current shunt	Ohm Labs CS-3	1 A and 3 A Current Measurement and Output	Only available on request; use the following format: CS-3-1 = 3 A, 1 V, 0.333 $\Omega$ .
Low Thermal EMF Copper Cables	Fluke 5440A-7003, 24 inch	1 $\mu$ A and 10 $\mu$ A Current Measurement and Output and 1 A and 3 A Current Measurement and Output	Low Thermal Copper EMF Plug-In Cables, Spade Connectors
PXI Express Chassis	PXIe-1095	—	If this chassis is unavailable, use a PXI Express chassis with $\geq$ 58 W slot cooling capacity.

Instrument	Recommended Model	Where Used	Requirements
PXIe-4147 Calibration Accessories Kit	NI part number 787792-01. Kit includes: <ul style="list-style-type: none"> <li>• DB25 to Low-Thermal EMF Spade Lug Assembly</li> <li>• DB25 to Triax/Spade Lug Assembly</li> <li>• HI Sense Verification Assembly</li> <li>• LO Sense Verification Assembly</li> <li>• Output Shorting Assembly</li> </ul>	All parameters	—

## Test Conditions

The following setup and environmental conditions are required to ensure the PXIe-4147 meets published specifications.

- For maximum accuracy, perform the ACAL function of the digital multimeter (DMM) prior to calibration if it has not been performed within the last 24 hours or when the multimeter's temperature changes by  $\pm 1$  °C from the last autocalibration. Always disconnect any input signals before performing autocalibration.
- Maintain an ambient temperature of  $23$  °C  $\pm 5$  °C for Verification and  $23$  °C  $\pm 1$  °C for Adjustment.
- Ensure that all connections to the DUT, including front panel connections and screws, are secure.

- Conduct tests with only one DUT in the chassis. Ensure all remaining slots are empty and contain filler panels.
- If the DUT fails reverification after adjustment, ensure that the Test Conditions have been met before returning the DUT to NI.

## Device Setup

1. Install the PXIe-4147 in the PXIe chassis according to the instructions in the **NI DC Power Supplies and SMUs Getting Started Guide**.
2. Configure the hardware using Measurement & Automation Explorer (MAX).
3. Launch the Calibration Executive procedure and complete the setup wizard.



**Note** If the PXIe-4147 module fails after calibration, return it to NI for repair or replacement. In the PXIe-4147 calibration report, the Low and High Limit columns list the error limits and the Reading column lists the actual Test Point error/accuracy.

## Test Limit Equations

The following test limits are derived from the published specifications.

**Table 243.** PXIe-4147 Test Limit Equations

Equation Type	Equation
Voltage Measurement and Output Verification	Voltage Measurement Test Limits = $\pm ( \text{Test Point}  * \% \text{ of Voltage} + \text{Offset})$
Voltage Remote Sense Verification	Remote Sense Error = $ V2 - V1 $ , <ul style="list-style-type: none"> <li>• where               <ul style="list-style-type: none"> <li>◦ V1 is the voltage measured when the test point is 0 mA and</li> <li>◦ V2 is the voltage measured when the test point is 1 mA.</li> </ul> </li> </ul>
1 $\mu\text{A}$ and 10 $\mu\text{A}$ Current Measurement and Output Verification	Current Measurement Test Limits = $\pm ( \text{DMM Measured Current}  * \% \text{ of Current} + \text{Offset})$

Equation Type	Equation
	<ul style="list-style-type: none"> <li>where DMM Measured Current is the voltage measured across the shunt and divided by the shunt calibrated value</li> </ul>
100 µA and 100 mA Current Measurement and Output Verification, 3 A Current Measurement and Output Verification	Current Measurement Test Limits = $\pm ( \text{Test Point}  * \% \text{ of Current} + \text{Offset})$
Remote Sense Voltage Offset Verification, Current Offset Verification, Load Regulation Verification	TestLimits = $\pm \text{AbsoluteAccuracy}$

Refer to the PXIe-4147 Calibration Procedure on [ni.com/docs](http://ni.com/docs) for specific values used for the as-found and as-left limits.

**Related concepts:**

- [Launching a Calibration Procedure](#)

## PXIe-4154 Calibration Procedure

Calibrate the PXIe-4154 using Calibration Executive.

### Calibration Executive Procedure Features

Verify only ✓	Verify & Adjust ✓	Manual Mode <ul style="list-style-type: none"> <li>• DMM ✓</li> <li>• External Current Source ✓</li> <li>• Programmable Electronic Load ✓</li> <li>• Digital Oscilloscope ✗</li> </ul>	Optional Adjust ✗
---------------	-------------------	--	-------------------

### Approximate Test Time

100 minutes



## Test Equipment

The following table lists the test instruments required for calibrating the PXIe-4154.

**Table 312.** Test equipment for calibrating the PXIe-4154

Instrument	Recommended Model	Specification	Value
DMM (x2)	PXI-4071	All Parameters	<p><b>DC Voltage</b></p> <p>0.1 V Range/1 V Range: Accuracy better than <math>\pm 50</math> ppm of Reading + 18 <math>\mu\text{V}</math> of Offset and a resolution better than 1 <math>\mu\text{V}</math></p> <p>resolution10 V Range: Accuracy better than <math>\pm 50</math> ppm of Reading + 60 <math>\mu\text{V}</math> of Offset and a resolution better than 10 <math>\mu\text{V}</math> resolution</p>
100 m $\Omega$ Precision Current Shunt	Guildline 9230A-15R, Ohm Labs Cs10	Current Output and Measurement	$\pm 100$ ppm tolerance, $\pm 50$ ppm stability, $\pm 5$ ppm/ $^{\circ}\text{C}$ temperature coefficient, Minimum current 10 A, 4-wire kelvin sense
100 $\Omega$ Precision Current Shunt	Vishay Y1453100R000T9L	Current Output and Measurement	$\pm 100$ ppm tolerance, $\pm 50$ ppm stability, $\pm 5$ ppm/ $^{\circ}\text{C}$ temperature coefficient, Minimum power rating 0.5 W
External Current Source	Fluke 5500A, Fluke 5520A, Fluke 5522A	Current Measurement	Current output of at least 3 A. Less than 8 $\mu\text{A}$ RMS Normal Mode Current Noise.
Programmable Electronic Load with Dynamic Current Capability	Agilent N3302A	Load Regulation, Transient Response, Output Resistance	Constant Current mode with the ability to sink at least 3 A and dynamic mode capable of doing a 0.1 A to 1.5 A step with a period of 5 mS and slew rate of at least 200 mA/ $\mu\text{S}$ .
Digital Oscilloscope	PXI-5124	Transient Response	Sampling rate of at least 200 MS/s and edge triggering capability
22.6 $\Omega$ Resistor	Vishay	Remote	1% tolerance, 1/4 W, $\pm 10$ ppm/ $^{\circ}\text{C}$

Instrument	Recommended Model	Specification	Value
(x2)	PTF22R600FYBF	Sense Output	
200 $\Omega$ Resistor	Vishay PTF65200R00AZEB	Remote Sense Output	0.05% tolerance, 1/4 W, $\pm 10$ ppm/ $^{\circ}$ C
Cable (x2)	Belden 8760-BEL	Transient Response	3 ft., 18 AWG, twisted-pair

## Test Conditions

The following setup and environmental conditions are required to ensure the PXIe-4154 meets published specifications.

- Keep connections to the device as short as possible. Long cables and wires act as antennas, picking up extra noise that can affect measurements
- Verify that all connections to the device, including front panel connections, are secure.
- Ensure that the PXI Express chassis fan speed is set to HIGH, that the fan filters are clean, and that the empty slots contain filler panels. For more information, refer to the ***Maintain Forced-Air Cooling Note to Users*** document available at [ni.com/docs](http://ni.com/docs).
- Keep the relative humidity between 10% and 70%, noncondensing.
- Allow a warm-up time of at least 30 minutes after NI-DCPower is loaded. Unless manually disabled, the NI-DCPower driver automatically loads with the operating system and enables the device. Allow the recommended warm-up time for all additional test equipment.
- Use characterized values in all instances where precision shunt resistance is measured.
- Use shielded copper wire for all cable connections to the device. Use twisted-pair wire to eliminate noise and thermal offsets. Use separate twisted-pair wires for Output + and Output - pins and Sense + and Sense - pins. The following figure shows an example of this connection.

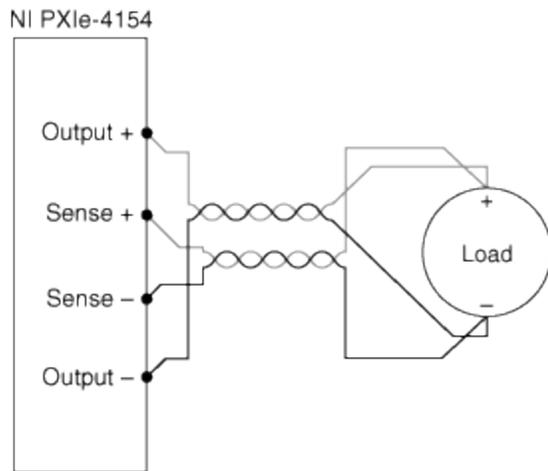

- Plug the chassis and the instrument standard into the same power strip to avoid ground loops.

## Device Setup

1. Install the PXIe-4154 in the PXI Express chassis according to the instructions in the ***NI DC Power Supplies and SMUs Getting Started Guide***.
2. Configure the hardware using Measurement & Automation Explorer (MAX).
3. Launch the Calibration Executive procedure. Calibration Executive guides you through the required connections.



**Note** For the transient response tests, the connecting cable must be built properly. Use one 3-foot, 18 AWG twisted-pair cable to connect Output + and Output - to the electronic load, and another 3-foot, 18 AWG twisted-pair cable to connect Sense + and Sense - to the electronic load. To ensure signal integrity, the cable shields should be terminated to the ground.

## Test Limit Equations

The following test limits are derived from the published specifications.

**Table 251.** PXIe-4154 Test Limit Equations

Equation Type	Equation
Voltage Output Accuracy	Test Limit = TestValue $\pm$ [abs(TestValue) * % of reading + offset]
Voltage Measurement Accuracy	Test Limit = TestValue $\pm$ [abs(TestValue) * % of

Equation Type	Equation
	reading + offset]
Current Output Accuracy	Test Limit = TestValue $\pm$ [abs(TestValue) * % of reading + offset]
Current Measurement Accuracy	Test Limit = TestValue $\pm$ [abs(TestValue) * % of reading + offset]
Output Resistance	Test Limit = TestValue $\pm$ [abs(TestValue) * % of reading + offset]
Current Load Regulation	Test Limit = $\pm$ [0.01% * Current Range * (V1 - V2)] <ul style="list-style-type: none"> <li>where V1 and V2 are the measured voltage output levels specified by the calibration procedure</li> </ul>
Voltage Load Regulation	Test Limit (Ch0) = $\pm$ [(I1 - I2) * 3mV] Test Limit (Ch1) = $\pm$ [(I1 - I2) * 1mV] <ul style="list-style-type: none"> <li>where I1 and I2 are the measured current output levels specified by the calibration procedure</li> </ul>
Remote Sense Accuracy	Test Limit = TestValue $\pm$ [abs(TestValue) * % of reading + offset] + [Remote Sense Error]
Transient Response (Dip Level)	Test Limit = 0 < Reading < Max Dip Level
Transient Response (Response Recovery Time)	Test Limit = 0 < Reading < Response Recovery Time

## PXIe-4162/4163 Calibration Procedure

Calibrate the PXIe-4162 or PXIe-4163 using Calibration Executive.

### Calibration Executive Procedure Features

Verify Only ✓	Adjust Only ✓	Verify & Adjust ✓	Manual Mode ✗	Optional Adjust ✗
---------------	---------------	-------------------	---------------	-------------------

## Approximate Test Time

**Table 250.** Approximate Test Times for the PXIe-4162

Run Options	Warm-up	As-Found Verify Steps	Adjust Steps	As-Left Verify Steps	Total
Verify Only	30 minutes	30 minutes	—	—	1 hour
Adjust Only	30 minutes	—	20 minutes	—	50 minutes
Verify & Adjust	30 minutes	30 minutes	20 minutes	30 minutes	1 hour 50 minutes

**Table 247.** Approximate Test Times for the PXIe-4163

Run Options	Warm-up	As-Found Verify Steps	Adjust Steps	As-Left Verify Steps	Total
Verify Only	30 minutes	35 minutes	—	—	1 hour 5 minutes
Adjust Only	30 minutes	—	30 minutes	—	1 hour
Verify & Adjust	30 minutes	35 minutes	30 minutes	35 minutes	2 hours 10 minutes

## Test Equipment

The following table lists the test instruments required for calibrating the PXIe-4162/4163.

**Table 312.** Test equipment for calibrating the PXIe-4162/4163

Required Equipment	Recommended Model	Parameter Measured	Minimum Requirements
PXIe-4162/4163 Calibration Accessories Kit	NI part number 787490-01 kit includes: <ul style="list-style-type: none"> <li>CAL-4162/63 Calibration Switch</li> </ul>	All Parameters	<ul style="list-style-type: none"> <li>Thermal EMF: <math>\pm 20 \mu\text{V}</math></li> <li>2-Wire path resistance: <math>\leq 5 \Omega</math></li> <li>4-Wire path resistance: <math>\leq 1 \Omega</math></li> </ul>

Required Equipment	Recommended Model	Parameter Measured	Minimum Requirements
	Fixture SHDB62M-DB62M-LL <ul style="list-style-type: none"> <li>• 62-Pin D-SUB cable for SMUs, low leakage</li> <li>• 1 M Type LV4-BAN4 cable assembly</li> <li>• 1 M Male-to-Male Triax cable assembly, 300 V isolation, low noise, low leakage</li> <li>• 1 M PXIe-4162/4163 output shorting assembly</li> </ul>		$\Omega$ <ul style="list-style-type: none"> <li>• 3 k<math>\Omega</math> resistor: <math>\pm 3 \Omega</math></li> <li>• 1 M<math>\Omega</math> measurement path (functional verification): <math>\pm 300 \Omega</math> (IET Labs SRL-1M/1 Triax value)</li> <li>• Leakage verification (functional verification): <math>&gt; 5 \text{ G}\Omega</math></li> </ul>
Digital Multimeter (DMM)	PXIe-4081	All parameters except load regulation verification and remote sense accuracy	<ul style="list-style-type: none"> <li>• Voltage accuracy: <math>\pm(50 \text{ ppm} + 500 \mu\text{V})</math></li> <li>• Voltage resolution: 100 <math>\mu\text{V}</math></li> <li>• Current accuracy:                             <ul style="list-style-type: none"> <li>◦ 100 <math>\mu\text{A}</math> to 10 mA range: <math>\pm(200 \text{ ppm} + 40 \text{ ppm of range})</math></li> <li>◦ 100 mA range: <math>\pm(200 \text{ ppm} + 20 \text{ ppm of range})</math></li> </ul> </li> <li>• Current resolution: 1 ppm of range</li> </ul>
PXI Relay Module	PXI-2520	All parameters	You must use the PXI-2520
1 M $\Omega$ current shunt	IET Labs SRL-1M/1 Triax	1 $\mu\text{A}$ /10 $\mu\text{A}$ current accuracy	<ul style="list-style-type: none"> <li>• Accuracy: <math>\pm 150 \text{ ppm}</math></li> <li>• Tempco: 10 ppm/<math>^{\circ}\text{C}</math></li> </ul>
Low thermal test leads	Fluke 5440	1 $\mu\text{A}$ /10 $\mu\text{A}$ current accuracy	Shielded, twisted pair copper cables with copper or gold-plated copper banana plugs

Required Equipment	Recommended Model	Parameter Measured	Minimum Requirements
Banana plug patch cord	Pomona B-4	1 $\mu$ A/10 $\mu$ A current accuracy	—
PXI Express Chassis	PXIe-1092 or PXIe-1095	—	If these chassis are unavailable, use a PXI Express chassis with $\geq 58$ W slot cooling capacity.

## Test Conditions

The following setup and environmental conditions are required to ensure the PXIe-4162/4163 meets published specifications.

- To ensure proper operation of the CAL-4162/63 and its connection to the PXI-2520, you must periodically test its performance. Consider the conditions specific to your test setup, including how often the relays are used, to determine how frequently to execute the switch fixture assembly performance test. Refer to ***CAL-4162/4163 with PXI-2520 Switch Fixture Assembly Performance Test*** for more information.
- Keep connections to the device as short as possible. Long cables and wires act as antennas, picking up extra noise that can affect measurements
- Verify that all connections to the device, including front panel connections and screws, are secure.
- Ensure that the PXI Express chassis fan filters are clean and that the empty slots contain filler panels. For more information, refer to the ***Maintain Forced-Air Cooling Note to Users*** document available at [ni.com/docs](http://ni.com/docs).
- Keep the relative humidity between 10% and 70%, noncondensing.
- Allow a warm-up time of at least 30 minutes after the chassis is powered on and NI-DCPower is loaded and recognizes the PXIe-4162/4163. The warm-up time ensures that the PXIe-4162/4163 and test instrumentation are at a stable operating temperature.
- Use shielded copper wire for all cable connections to the device. Use twisted-pair wire to eliminate noise and thermal offsets.
- For verification procedures, maintain an ambient temperature of  $23\text{ }^{\circ}\text{C} \pm 5\text{ }^{\circ}\text{C}$ .
- For adjustment procedures, maintain an ambient temperature of  $23\text{ }^{\circ}\text{C} \pm 1\text{ }^{\circ}\text{C}$ . The

PXIe-4162/4163 internal temperature is greater than the ambient temperature.

## Device Setup

1. Install the PXIe-4162/4163 in the PXI Express chassis according to the instructions in the ***NI DC Power Supplies and SMUs Getting Started Guide***.
2. Configure the hardware using Measurement & Automation Explorer (MAX).
3. Launch the Calibration Executive procedure and complete the setup wizard.



### Note

- In the PXIe-4162/4163 calibration report, the **Low Limit** and **High Limit** columns list the error limits and the **Reading** column lists the test point error/accuracy.
- If the PXIe-4162/4163 fails after calibration, return it to NI for repair or replacement.

## Test Limit Equations

The following test limits are derived from the published specifications.

**Table 251.** PXIe-4162/4163 Test Limit Equations

Equation Type	Equation
Voltage Measurement and Output Verification	<p>Voltage Measurement Test Limits = <math>\pm ( \text{Test Point}  * \% \text{ of Voltage} + \text{Offset})</math></p> <p>Voltage Output Test Limits = <math>\pm ( \text{DMM Measured Voltage}  * \% \text{ of Voltage} + \text{Offset})</math></p>
Verifying Voltage Remote Sense	Ideal Voltage Output = $(1 \text{ mA} * \text{DMM Measured Fixture Load (Nominal } 3 \text{ k}\Omega))$
1 $\mu\text{A}$ and 10 $\mu\text{A}$ Current Measurement and Output Verification	DMM Measured Current is the DMM measured voltage, measured across the shunt, and is divided by the shunt calibrated value.



Equation Type	Equation
Verifying Load Regulation (Functional Test)	<p>Load regulation Error = <math>V_2 - V_1</math></p> <p><math>V_1</math> is PXIe-4162/4163 measured value at 0 mA</p> <p><math>V_2</math> is PXIe-4162/4163 measured value at 10 mA</p>
Adjusting Resistor Reference	<p><math>R = (1/((1/R_{ref}) - (1/R_{10M}))) - R_{gnd}</math></p> <p><math>R_{ref}</math> = DMM measured resistance value with Internal Reference set to 100 k<math>\Omega</math></p> <p><math>R_{gnd}</math> = DMM measured resistance value with Internal Reference set to GND</p> <p><math>R_{10M}</math> = DMM measured resistance value with Internal Reference set to None</p>
Adjusting Voltage Measurement and Output	<p><math>V = V_{ref} * (1 + (20 \text{ k}\Omega/R_{10M})) - V_{gnd}</math></p> <p><math>V_{ref}</math> = DMM Measured Voltage with Internal Reference set to 5V</p> <p><math>R_{10M}</math> = DMM Measured resistance value from Adjusting Resistor Reference with Internal Reference set to None</p> <p><math>V_{gnd}</math> = DMM Measured Voltage with Internal Reference set to GND</p>

Refer to the **PXIe-4162/4163 Calibration Procedure** on [ni.com/docs](http://ni.com/docs) for specific values used for the as-found and as-left limits.

### CAL-4162/4163 with PXI-2520 Switch Fixture Assembly Performance Test

Verify the performance of the CAL-4162/4163 using Calibration Executive.

## Calibration Executive Procedure Features

Verify Only 	Adjust Only 	Verify & Adjust 	Manual Mode 	Optional Adjust 
---	---	---	---	---

## Approximate Test Time

Run Options	Warm-up	As-Found Verify Steps	Adjust Steps	As-Left Verify Steps	Total
Verify Only	30 minutes	30 minutes	—	—	1 hour

## Test Equipment

The following table lists the test instruments required for calibrating the CAL-4162/4163.

**Table 312.** Test equipment for calibrating the CAL-5501 the CAL-4162/4163 with PXI-2520 switch fixture assembly

Required Equipment	Recommended Model	Parameter Measured	Minimum Requirements
PXIe-4162/4163 Calibration Accessories Kit	NI part number 787490-01 kit includes: <ul style="list-style-type: none"> <li>CAL-4162/63 Calibration Switch Fixture SHDB62M-DB62M-LL</li> <li>62-Pin D-SUB cable for SMUs, low leakage</li> <li>1 M Type LV4-BAN4 cable assembly</li> <li>1 M Male-to-Male Triax cable assembly, 300 V isolation, low noise, low leakage</li> <li>1 M PXIe-4162/4163 output shorting assembly</li> </ul>	All Parameters	<ul style="list-style-type: none"> <li>Thermal EMF: <math>\pm 20 \mu\text{V}</math></li> <li>2-Wire path resistance: <math>\leq 5 \Omega</math></li> <li>4-Wire path resistance: <math>\leq 1 \Omega</math></li> <li>3 k<math>\Omega</math> resistor: <math>\pm 3 \Omega</math></li> <li>1 M<math>\Omega</math> measurement path (functional verification): <math>\pm 300 \Omega</math> (IET Labs SRL-1M/1 Triax value)</li> <li>Leakage verification (functional verification): <math>&gt; 5 \text{ G}\Omega</math></li> </ul>

Required Equipment	Recommended Model	Parameter Measured	Minimum Requirements
Digital Multimeter (DMM)	PXIe-4081	All parameters except load regulation verification and remote sense accuracy	<ul style="list-style-type: none"> <li>• Voltage accuracy: <math>\pm(50 \text{ ppm} + 500 \mu\text{V})</math></li> <li>• Voltage resolution: 100 <math>\mu\text{V}</math></li> <li>• Current accuracy: <ul style="list-style-type: none"> <li>◦ 100 <math>\mu\text{A}</math> to 10 mA range: <math>\pm(200 \text{ ppm} + 40 \text{ ppm of range})</math></li> <li>◦ 100 mA range: <math>\pm(200 \text{ ppm} + 20 \text{ ppm of range})</math></li> </ul> </li> <li>• Current resolution: 1 ppm of range</li> </ul>
PXI Relay Module	PXI-2520	All parameters	You must use the PXI-2520
1 M $\Omega$ current shunt	IET Labs SRL-1M/1 Triax	1 $\mu\text{A}$ /10 $\mu\text{A}$ current accuracy	<ul style="list-style-type: none"> <li>• Accuracy: <math>\pm 150 \text{ ppm}</math></li> <li>• Tempco: 10 ppm/<math>^{\circ}\text{C}</math></li> </ul>
Low thermal test leads	Fluke 5440	1 $\mu\text{A}$ /10 $\mu\text{A}$ current accuracy	Shielded, twisted pair copper cables with copper or gold-plated copper banana plugs
Banana plug patch cord	Pomona B-4	1 $\mu\text{A}$ /10 $\mu\text{A}$ current accuracy	—

## Test Conditions

The following setup and environmental conditions are required to ensure the CAL-4162/4163 meets functional requirements.

- Keep connections to the device as short as possible. Long cables and wires act as antennas, picking up extra noise that can affect measurements
- Verify that all connections to the device, including front panel connections and screws, are secure.
- Keep the relative humidity between 10% and 70%, noncondensing.

- Maintain an ambient temperature of  $23\text{ }^{\circ}\text{C} \pm 5\text{ }^{\circ}\text{C}$ . The CAL-4162/4163 internal temperature is greater than the ambient temperature.

## Device Setup

1. Install the CAL-4162/4163 in the PXI Express chassis..
2. Launch the Calibration Executive procedure and complete the setup wizard.



### Note

- In the CAL-4162/4163 calibration report, the **Low Limit** and **High Limit** columns list the error limits and the **Reading** column lists the test point error/accuracy.
- If the CAL-4162/4163 fails after calibration, return it to NI for repair or replacement.

## Test Limits

The following test limits are derived from the published specifications.

**Table 251.** PXIe-4162/4163 Test Limits

Measurement	Limit
Thermal EMF	$\pm 20\text{ }\mu\text{V}$
2-Wire path resistance	$\leq 5\text{ }\Omega$
4-Wire path resistance	$\leq 1\text{ }\Omega$
3 k $\Omega$ resistor	$\pm 3\text{ }\Omega$
1 M $\Omega$ measurement path (functional verification)	IET Labs SRL-1M/1 Triax value: $\pm 300\text{ }\Omega$
Leakage verification (functional verification)	$> 5\text{ G}\Omega$

## RMX-412x Calibration Procedure

Calibrate the RMX-4124 and RMX-4125 using Calibration Executive.



**Hazardous Voltage** The RMX-412x devices are capable of generating voltages that can be hazardous to users ( $\pm 200$  VDC). It is the responsibility of the system designer, integrator, installer, maintenance personnel, and service personnel to make sure that the module is used safely.

## Calibration Executive Procedure Features

Verify Only ✓	Verify & Adjust ✓	Manual Mode ✓	Optional Adjust ⓧ
---------------	-------------------	---------------	-------------------

## Approximate Test Time

Verify Only	Adjust Only	Verify & Adjust
10 minutes	15 minutes	35 minutes

## Test Equipment

The following table lists the test instruments and equipment required for calibrating the RMX-4124 and RMX-4125 devices.



**Note** Alternate equipment may be used as long as the necessary accuracy and resolution requirements are met.

**Table 312.** Test equipment for calibrating the RMX-4124 and RMX-4125

Equipment	Recommended Model	Devices	Minimum Requirements
Digital Multimeter	PXI-4071	All	Multiranging 7 1/2-digit DMM
200 A Current Shunt	Ohm Labs, CS-200	RMX-4124/ 4125	0.02% Accuracy
Welding cable (x2)	Crimp Supply, P/N: 20A19001/20A19002	RMX-4125	75 A rating, 6 AWG
6-gauge lug (x2)	Grainger 23YY88	RMX-4125	3/8-inch stud
6-gauge lug (x2)	Grainger 23YY87	RMX-4125	5/16-inch stud
Welding cable (x2)	Crimp Supply, P/N:	RMX-4124	150 A rating, 1/0 AWG

Equipment	Recommended Model	Devices	Minimum Requirements
	20A19009/20A19010		
1/0-gauge lug (x4)	Grainger 23ZA12	RMX-4124	3/8-inch stud
Spade lug-to-shrouded banana jack (x2)	Pomona 6203	All	Operating Voltage: 1000 V <sub>rms</sub>
Retractable sheath banana plug (each end) patch cord (x2)	Pomona 4911A-24	All	Operating Voltage: 1000 V <sub>rms</sub> IEC 1010-2-31, Category III
USB Type A-to-Type B cable	—	All	—
M8 bolt set	M8 bolt with washer and nut	RMX-4124/ 4125	—
RMX Output Terminal Cover	Safety cover for the RMX output terminals.	All	—
RMX Connector Safety Cover	Safety cover for the sensing J1 and J2 connectors.	All	—



## Note

- \*Required equipment varies according to DUT; refer to the "Devices" column for the specific RMX-412x devices you are calibrating.
- †The RMX-412x device ships with a fully assembled cable, but users can assemble their own cable using the part numbers from table.
- ‡RMX devices ship with the required safety covers. Contact NI if you require replacement or spare covers.

## Test Conditions

The following setup and environmental conditions are required to ensure the RMX-412x devices meet published specifications.

- Keep connections to the device as short as possible. Long cables and wires act as antennas, picking up extra noise that can affect measurements.
- Verify that all connections, including front panel connections and screws, are

secure.

- Maintain an ambient temperature of  $23\text{ }^{\circ}\text{C} \pm 5\text{ }^{\circ}\text{C}$ . The device temperature will be greater than the ambient temperature.
- Keep the relative humidity below 80%, noncondensing.
- Warm up the RMX programmable power supply for at least 30 minutes before calibration.

## Considerations for Testing at High Voltage

The following conditions help ensure that the RMX-412x devices can be used safely at high voltage.

- Always power off the RMX device prior to touching the output terminals.
- Use shrouded connectors and safety enclosures for all high voltage test points.
- Before executing this procedure, refer to the RMX Programmable Power Supplies User Manual, available at [ni.com/docs](http://ni.com/docs), for specific instructions on installing the cables and safety enclosures to ensure the safety of the connections.

## Device Setup

Refer to the RMX Programmable Power Supplies User Manual and the RMX Programmable Power Supplies Safety Information and Installation Guide, available at [ni.com/docs](http://ni.com/docs), for important information about device setup, connection procedures, and safety guidance.

1. Install RMX-412x device according to the instructions in the RMX Programmable Power Supplies Safety Information and Installation Guide.
2. Configure the hardware using Measurement & Automation Explorer (MAX).
3. Launch the Calibration Executive procedure, and complete the setup wizard.



**Note** In some cases, Windows does not find the correct device driver for the RMX-412x, and the RMX device appears in MAX as an unknown device. For information about resolving this issue, refer to USB Device Missing In NI MAX but Is Present In Windows Device Manager on [ni.com](http://ni.com).

## Connect Your Signal to the RMX Output Terminal

During the calibration of the RMX, the cables need to be changed when transitioning from Voltage to Current Verification/Adjustment. Refer to the RMX Programmable Power Supplies User Manual and the following when changing the connections.



**Hazardous Voltage** Risk of electric shock and damage to internal circuits.

Turn the POWER switch off before you touch the OUTPUT terminals. Even if you turn the output off or turn the POWER switch off, if the bleeder on/off setting (CF11) is set to OFF, the voltage that was present when the output was on will remain at the output terminals.

Calibration Executive changes the bleeder setting to ON before the verification/adjustment procedure begins. If Calibration Executive is unable to set the bleeder to ON, it stops running the procedure and displays an error message.



**Note** Regardless of whether load cables are connected to the output terminals, be sure to attach the OUTPUT terminal cover before turning the POWER switch on.

## Configure Local Sensing

The RMX calibration requires the DUT to be configured for Local Sensing. Refer to "Sensing" in the RMX Programmable Power Supplies User Manual to configure the sensing for the DUT.

## Test Limit Equations

Test limits are derived from specifications published in the RMX Programmable Power Supplies User Manual.

### Related concepts:

- [Launching a Calibration Procedure](#)



**Related information:**

- [USB Device Missing In NI MAX but Is Present In Windows Device Manager](#)

## RF Devices

Calibrate your RF devices with Calibration Executive.

### PXIe-5601 Calibration Procedure

Calibrate the PXIe-5601 using Calibration Executive.

### Calibration Executive Procedure Features

Verify Only ✓	Verify & Adjust ✓	Manual Mode ✓	Optional Adjust ✗
---------------	-------------------	---------------	-------------------

### Approximate Test Time

Verify Only	Verify & Adjust
50 minutes	180 minutes



**Note** The PXIe-5601, PXIe-5622 IF digitizer, and PXI-5652 RF signal generator compose the PXIe-5663 RF vector signal analyzer.

### Test Equipment

The following table lists the test instruments required for calibrating the PXIe-5601.

**Table 312.** Test equipment for calibrating the PXIe-5601

Instrument	Recommended Model	Specification	Value
Power Meter	Anritsu ML2438A	Display Resolution	<0.01 dB
		Settling	<0.1%
		Instrument Accuracy	<0.5%
		Noise	<0.5% full-scale

Instrument	Recommended Model	Specification	Value	
			(lowest range)	
		Zero Set and Drift	<0.5% full-scale (lowest range)	
		Reference Power Uncertainty	<0.9%	
		Reference Output VSWR	<1.04:1	
(2) Power Sensors	Anritsu MA2473D	Input VSWR	10 MHz to 50 MHz	<1.9:1
			50 MHz to 150 MHz	<1.17:1
			150 MHz to 2 GHz	<1.12:1
			2 GHz to 12.4 GHz	<1.22:1
		Linearity	-70 dBm to 20 dBm	<1.8%
		Rise Time		<4 $\mu$ s
		Calibration Factor Uncertainty	50 MHz	<1.48%
			100 MHz	<1.37%
			300 MHz	<1.42%
			500 MHz	<0.96%
			1 GHz	<0.99%
			2 GHz	<1.04%
			3 GHz	<1.05%
			4 GHz	<1.64%
5 GHz	<1.39%			
6 GHz	<1.45%			
7 GHz	<1.26%			
Signal Generator (LO Source)	PXI-5652	—	—	

Instrument	Recommended Model	Specification	Value	
Signal Generator (RF Source)	Anritsu MG3692B	Frequency Range	10 MHz to 6.6 GHz	
		Power Level	-60 dBm to 20 dBm	
Spectrum Analyzer	Rohde & Schwarz FSU26	Frequency Range	10 MHz to 6.6 GHz	
		Power Level	-60 dBm to 20 dBm	
		Resolution Bandwidth	10 Hz to 1 MHz	
		Phase Noise	100 Hz	-100 dBc/Hz
			1 kHz	-120 dBc/Hz
			10 kHz	-130 dBc/Hz
100 kHz	-130 dBc/Hz			
1 MHz	-142 dBc/Hz			
Chassis	PXIe-1065, PXIe-1075	—	—	
Chassis Controller	NI MXI-Express Kit	—	—	
SMA (m) to SMA (f) Right Angle Adapter	Huber+Suhner 53_SMA-50-0-2/111_N	—	—	
3.5 mm (m) to 3.5 mm (m) Adapter	Huber+Suhner 32_Pc35-50-0-2/199_NE	—	—	
(2) 50 $\Omega$ Terminators	NI SMA 50 $\Omega$ Termination Plug	—	—	
3.5 mm (f) Power Splitter (2 Resistor Type)	Aeroflex 1593	—	—	
(2) 36 in SMA (m) to SMA (m) Cables	Huber+Suhner ST-18/SMAm/36	—	—	
3.5 mm (m) to 3.5 mm (f) 30 dB Attenuator	Huber+Suhner 6630_SMA-50-1/199_NE	—	—	
SMA Torque Wrench	Agilent 8710-1582	—	5 in/lb	

Instrument	Recommended Model	Specification	Value
3.5 mm Torque Wrench	Agilent 8710-1765	—	8 in/lb



**Note** NI strongly recommends using the instruments specified above when calibrating the PXIe-5601 module. Substitution of instruments is permitted by Calibration Executive software, but NI cannot guarantee that unsupported instruments meet the specifications required for calibration.

## Test Conditions

The following setup and environmental conditions are required to ensure the PXIe-5601 meets published specifications.

- Maintain an ambient temperature of  $23\text{ °C} \pm 5\text{ °C}$ .
- Keep the relative humidity between 10% and 90%, noncondensing.
- Ensure that the PXI Express chassis fan speed is set to HIGH, that the fan filters are clean, and that the empty slots contain filler panels. For more information, refer to the ***Maintain Forced-Air Cooling Note to Users*** document available at [ni.com/docs](http://ni.com/docs).
- Allow a warm-up time of at least 30 minutes after NI-RFSA is loaded and recognizes the PXIe-5601. The warm-up time ensures that the measurement circuitry of the PXIe-5601 is at a stable operating temperature.
- Use an SMA torque wrench (5 in/lb, Agilent 8710-1582 or equivalent) to tighten any connection with an SMA connector.
- Use a 3.5mm torque wrench (8 in/lb, Agilent 8710-1765 or equivalent) to tighten 3.5mm or 2.92mm (K) connections without an SMA connector.
- All tests assume a PXI-5652 as the LO source for the PXIe-5601.
- Lock all test equipment to the same reference frequency. Refer to the NI 5663 Timing Configuration topic in the NI RF Vector Signal Analyzers Help.

## Device Setup

1. Install the PXIe-5601 in the PXI Express chassis according to the instructions in the NI RF Vector Signal Analyzers Getting Started Guide.
2. Configure the hardware using Measurement & Automation Explorer (MAX).
3. Launch the Calibration Executive procedure. Calibration Executive guides you

through the required connections.

### Related concepts:

- [Launching a Calibration Procedure](#)

## PXIe-5606 Calibration Procedure

Calibrate the PXIe-5606 using Calibration Executive.

The PXIe-5606 RF Signal Downconverter, PXIe-5624 IF Digitizer, and PXIe-5653 RF Synthesizer are components of the PXIe-5668 Vector Signal Analyzer.

### Calibration Executive Procedure Features

Verify Only 	Adjust Only 	Verify & Adjust 	Manual Mode 	Optional Adjust 
---	---	---	---	---

### Approximate Test Time

160 minutes (adjust only)

### Test Equipment

The following table lists the test instruments required for calibrating the PXIe-5606. Refer also to test equipment tables for PXIe-5624, PXIe-5653, and PXIe-5668.

**Table 254.** Test equipment for calibrating the PXIe-5606

Instrument	Recommended Model	Where Used	Requirements
Power meter	Anritsu ML2438A	IF Gain Adjustment Lowband RF Response Highband RF Response	Display resolution: $\leq 0.01$ dB Settling: $\pm 0.1\%$ Instrumentation accuracy: $< \pm 0.5\%$ Noise, Zero Set, and Drift: $\leq$

Instrument	Recommended Model	Where Used	Requirements
		LO Output Power  Test system characterization	$\pm 0.5\%$ full-scale (lowest range)  Reference power uncertainty: $\leq \pm 1.2\%$  Reference output VSWR: $< 1.12 : 1$
Power sensor (x2)	Anritsu SC7413	IF Gain Adjustment  Lowband RF Response  Highband RF Response  LO Output Power  Test system characterization	Power range: -35 dBm to 5 dBm  Frequency range: 0.1 MHz to 26.9 GHz  Input VSWR: <ul style="list-style-type: none"> <li>• 0.1 MHz to <math>&lt; 10</math> MHz: <math>&lt; 1.04 : 1</math></li> <li>• 10 MHz to <math>&lt; 150</math> MHz: <math>&lt; 1.17 : 1</math></li> <li>• 150 MHz to <math>&lt; 2</math> GHz: <math>&lt; 1.08 : 1</math></li> <li>• 2 GHz to <math>&lt; 12.4</math> GHz: <math>&lt; 1.16 : 1</math></li> <li>• 12.4 GHz to <math>&lt; 18</math> GHz: <math>&lt; 1.21 : 1</math></li> <li>• 18 GHz to <math>&lt; 26.9</math> GHz: <math>&lt; 1.29 : 1</math></li> </ul> Linearity: <ul style="list-style-type: none"> <li>• <math>\leq 18</math> GHz: <math>&lt; 1.8\%</math></li> <li>• <math>&gt; 18</math> GHz to <math>&lt; 26.9</math> GHz: <math>&lt; 2.5\%</math></li> </ul> Calibration factor uncertainty ( $2\sigma$ ): Refer to PXIe-5606 documentation.
Signal generator	Anritsu MG3694C	IF Gain Adjustment	Frequency range: 16 kHz to

Instrument	Recommended Model	Where Used	Requirements
	<p>Options 1A, 2B, 4, 22, and 28B</p> <p>Note: Do not use option 15</p>	<p>Low Band Calibration</p> <p>High Band Calibration</p> <p>Test system characterization</p>	<p>26.9 GHz</p> <p>Leveled power: -30 dBm to 10 dBm</p> <p>Power accuracy: <math>\pm 1.5</math> dB</p> <p>Harmonics:</p> <ul style="list-style-type: none"> <li>• 16 kHz to <math>\leq 10</math> MHz: <math>&lt; -30</math> dBc</li> <li>• <math>&gt; 10</math> MHz to <math>\leq 100</math> MHz: <math>&lt; -40</math> dBc</li> <li>• <math>&gt; 100</math> MHz to <math>\leq 2.2</math> GHz: <math>&lt; -50</math> dBc</li> <li>• <math>&gt; 2.2</math> GHz to <math>\leq 20</math> GHz: <math>&lt; -60</math> dBc</li> <li>• <math>&gt; 20</math> GHz to <math>\leq 26.9</math> GHz: <math>&lt; -40</math> dBc</li> </ul> <p>Nonharmonic spurious:</p> <ul style="list-style-type: none"> <li>• 16 kHz to <math>\leq 10</math> MHz: <math>&lt; -30</math> dBc</li> <li>• <math>&gt; 10</math> MHz to <math>\leq 2.2</math> GHz: <math>&lt; -60</math> dBc</li> <li>• <math>&gt; 2.2</math> GHz to <math>\leq 26.9</math> GHz: <math>&lt; -60</math> dBc</li> </ul> <p>Output VSWR: <math>&lt; 2.0 : 1</math></p>
PXI Express chassis	PXIe-1075 or PXIe-1085	All test steps	—
PXI Express controller	PXIe-8133 or PXIe-8135	All test steps	—
50 $\Omega$ terminations (x4)*	NI 778353-01	All test steps	—
SMA-to-SMA cable, labeled U†	NI 152637A-01	All test steps	—

Instrument	Recommended Model	Where Used	Requirements
SMA-to-SMA cable, labeled V†	NI 152638A-01	All test steps	—
SMA-to-SMA cable, labeled W†	NI 152639A-01	All test steps	—
SMA-to-SMA cable, labeled X†	NI 152640A-01	All test steps	—
SMA-to-SMA cable, labeled Y†	NI 152641A-01	All test steps	—
2.92 mm (m)-to-2.92 mm (m) cables (36 in.) (x2)	Florida RF Labs KMS-160-36.0-KMS	IF Gain Adjustment  Lowband RF Response  Highband RF Response  Test system characterization	Frequency Range: 16 kHz to 26.9 GHz  Insertion Loss: ≤30 dB/100 ft at 5 GHz  Impedance: 50 Ω
2.92 mm (m)-to-2.92 mm (m) cables (12 in.) (x2)	Florida RF Labs KMS-160-12.0-KMS	LO Output Power	Frequency Range: 16 kHz to 26.9 GHz  Insertion Loss: ≤30 dB/100 ft at 5 GHz  Impedance: 50 Ω
2.92 mm (m)-to-2.92 mm (m) adaptor	Anritsu K220B	IF Gain Adjustment  Lowband RF Response  Highband RF Response  Test system characterization	Frequency range: 10 MHz to 26.9 GHz  Impedance: 50 Ω  VSWR: <1.12:1



Instrument	Recommended Model	Where Used	Requirements
2.92 mm (f)-to-2.92 mm (f) adaptor (x2)	Fairview Microwave SM4953	LO Output Power Test system characterization	Frequency range: 16 kHz to 26.9 GHz Impedance: 50 $\Omega$ VSWR: <1.15:1
Power splitter (two-resistor type)	Api Weinschel 1534	IF Gain Adjustment Lowband RF Response Highband RF Response Test system characterization	Frequency range: 10 MHz to 26.9 GHz Amplitude tracking: <0.50 dB Phase tracking: <4° Insertion loss: $\leq$ 10.5 dB Power rating: 1 W Impedance: 50 $\Omega$ VSWR: <ul style="list-style-type: none"> <li>• 10 MHz to 18 GHz <math>\leq</math>1.25 : 1</li> <li>• 18 to 26.5 GHz <math>\leq</math>1.4 : 1</li> <li>• 26.5 to 26.9 GHz <math>\leq</math>1.6 : 1</li> </ul> Equivalent output VSWR: <ul style="list-style-type: none"> <li>• 10 MHz to 26.5 GHz: <math>\leq</math>1.35 : 1</li> <li>• 26.5 GHz to 26.9 GHz: <math>\leq</math>1.6 : 1</li> </ul> Connectors: 2.92 mm (f)
Frequency reference source	Symmetricon 8040C rubidium frequency standard	All test steps	Frequency: 10 MHz Frequency Accuracy: $\leq 1 \times 10^{-9}$
Torque wrench	—	—	Refer to <b>Test Conditions</b> for torque wrench specifications.



## Note

- \*Three terminators are included in the PXIe-5668R cable accessory kit.
- †Included in the PXIe-5668R cable accessory kit.

## Test Conditions

The following setup and environmental conditions are required to ensure the PXIe-5606 meets published specifications.

- Keep cabling as short as possible. Long cables and wires act as antennas, picking up extra noise that can affect measurements.
- Verify that all connections, including front panel connections and screws, are secure.
- Maintain an ambient temperature of  $23\text{ }^{\circ}\text{C} \pm 5\text{ }^{\circ}\text{C}$ .
- Keep the relative humidity between 10% and 90%, noncondensing.
- Ensure that the PXI/PXI Express chassis fan speed is set to HIGH and that the empty slots contain filler panels. For more information about maintaining adequate air circulation in your PXI/PXI Express chassis, refer to the ***Maintain Forced-Air Cooling Note to Users*** document available at [ni.com/docs](http://ni.com/docs).
- Allow a warm-up time of at least 30 minutes after NI-RFSA is loaded and recognizes the NI 5606. The warm-up time ensures that the measurement circuitry of the NI 5606 is at a stable operating temperature.
- Use a torque wrench appropriate for the type of RF connector that you are using. NI recommends a  $0.565\text{ N}\cdot\text{m}$  (5 lb · in.) wrench for SMA connectors and an  $0.90\text{ N}\cdot\text{m}$  (8 lb · in.) wrench for 3.5 mm connectors.
- Connect the frequency reference source to the REF IN connector on the PXI Express chassis with a standard BNC (m)-to-BNC (m) cable. This connection replaces the connection from the NI 5653 REF OUT (10 MHz) connector to the PXI Express chassis REF IN connector, if present.
- Lock all test equipment to the REF OUT signal on the back of the Reference Frequency source. Refer to the ***NI 5668R Timing Configurations*** topic in the ***NI RF Vector Signal Analyzers Help*** for more information about configuring clocking sources.

## Device Setup

Refer to the ***PXIe-5668 Getting Started Guide*** for information about how to install the software and hardware and how to configure the device in Measurement & Automation Explorer (MAX).



**Note** A warmup begins when the procedure initializes. Warmup may cause indeterminate delay at the YTF Self Alignment step.

1. Install the hardware according to the instructions in the ***PXIe-5668R Getting Started Guide***.
2. Configure the hardware using Measurement & Automation Explorer (MAX). You must create a MAX association between the hardware modules to control them as a single RF device before you can program the device. Complete the following steps to make this association.
  - a. In MAX, select the NI 5606 RF downconverter in the configuration tree.
  - b. In the Associated Devices section, select the appropriate module from each system component drop-down listbox.

For NI 5668R, you must associate the NI 5624R IF digitizer module and the NI 5653 LO source module with the NI 5606 RF downconverter.



**Note** Device associations are lost when you move modules to different chassis slots.

- c. Click **Save** in the MAX toolbar.
3. Launch the Calibration Executive procedure. Calibration Executive guides you through the required connections.

## Connection Diagram

The following diagram shows the equipment and connections required for Test System Characterization. Components 2, 4, and 8 in the diagram create a "splitter fixture" that is handled as a single component. Do not alter connections inside this assembly during procedure execution.



**Note** Once Power Sensor B (5) is connected to the 2.92 (f)-to-2.92 (f) adaptor (7), it is recommended to keep them connected. This improves test time and decreases wear on the connectors.

Power meter (6) connected to RF source (1)

**Figure 16.** Connections for Test System Characterization

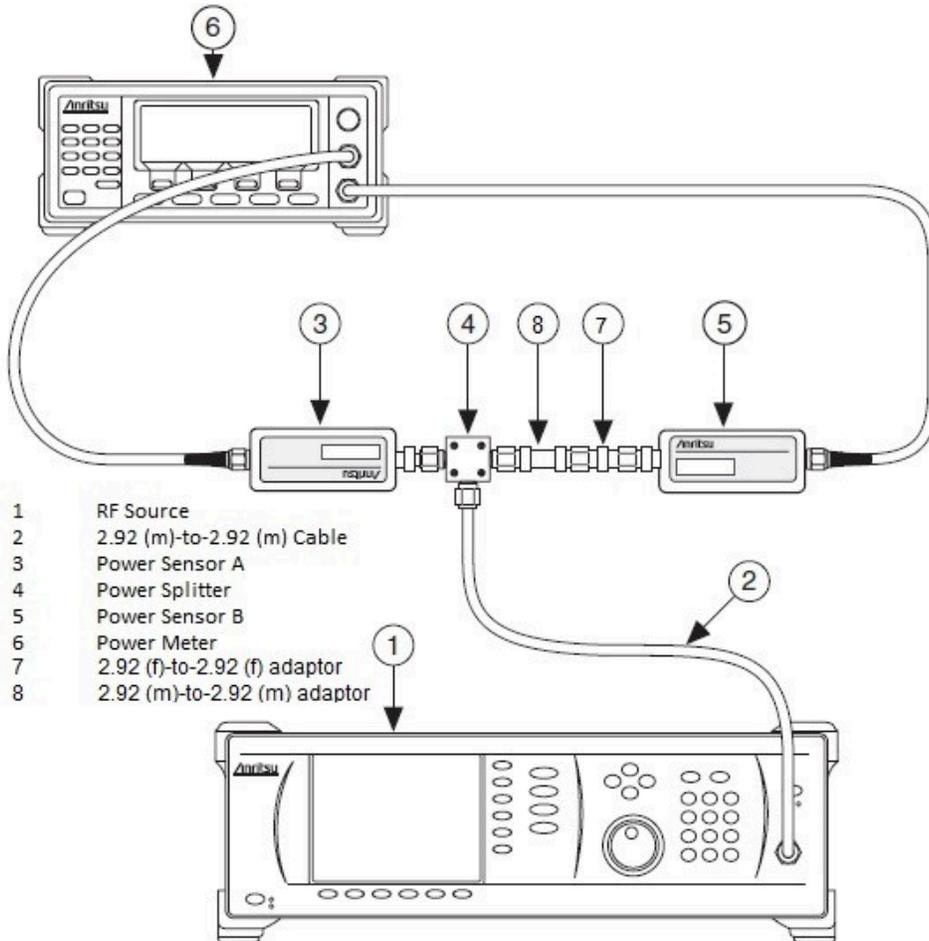

#### Related concepts:

- [Launching a Calibration Procedure](#)

#### Related information:

- [Getting Started with the PXI-5661](#)

## PXIe-5611 Calibration Procedure

Calibrate the PXIe-5611 using Calibration Executive.

### Calibration Executive Procedure Features

Verify Only ✓	Verify & Adjust ✓	Manual Mode ✓	Optional Adjust ✗
---------------	-------------------	---------------	-------------------

### Approximate Test Time

Verify Only	Verify & Adjust
45 minutes	180 minutes

### Test Equipment

The following table lists the test instruments required for calibrating the PXIe-5611.

**Table 312.** Test equipment for calibrating the PXIe-5611

Instrument	Recommended Model	Requirements
Spectrum Analyzer	Rohde & Schwarz FSU Spectrum Analyzer with high-frequency preamplifier option (B23)	Frequency Range: 50 MHz to 6.6 GHz Noise Floor: <-152 dBm/Hz to 6.6 GHz
Power Meter	Anritsu ML2438A with a Ma2472 diode sensor	Range: -50 dBm to +10 dBm Frequency range: 50 MHz to 6.6 GHz Accuracy: 0.5%
NI 5450	NI 5450	This device must be fully calibrated before calibrating the PXIe-5611
NI 5652	NI 5652	This device must be fully calibrated before calibrating the PXIe-5611

Instrument	Recommended Model	Requirements
Power Splitter	Aeroflex/Weinschel 1593	SWR: 1.25 Amplitude tracking: <0.25 dB
6 dB Attenuator	Anritsu 41KB-6	Frequency Range: DC to 12 GHz SWR: 1.1
50 $\Omega$ Terminator	NI SMA 50 $\Omega$ Termination Plug	—
Type N(f) to SMA(m) Adapter	S.M. Electronics Sm4241	VSWR: 1.15: 1
SMA Adapter Plug/Plug	Huber+Suhner 32_N-SMA-50-1/11-_NE	VSWR: 1.05: 1
SMA Torque Wrench	NI RF Torque Wrench	1 N · m
Connection Accessory	PXIe-5673 Cable Accessory Kit	(4) Matched-Length I/Q Semi-Rigid SMA Cable (1) LO Semi-Rigid SMA Cable (1) RF Flexible SMA Cable
BNC(m) to BNC(m) Cable	—	Use a cable that is 36 inches in length.
Chassis	PXIe-1065, PXIe-1075	—
Chassis Controller	NI MXI-Express Kit	—



**Note** NI strongly recommends using the instruments specified above when calibrating the PXIe-5611. Substitution of instruments is permitted by Calibration Executive software, but NI cannot guarantee that unsupported instruments meet the specifications required for calibration.

## Test Conditions

The following setup and environmental conditions are required to ensure the PXIe-5611 meets published specifications.

- Verify that the PXIe-5611, PXIe-5450, and the NI 5652 are properly connected as indicated in the NI RF Signal Generators Getting Started Guide.
- Verification limits are defined assuming the same PXIe-5611, PXIe-5450, and NI 5652 are used during verification and adjustment.
- Keep cabling as short as possible. Long cables act as antennas, picking up extra noise that can affect measurements.
- Verify that all connections, including front panel connections and screws, are secure.
- Ensure that the PXI Express chassis fan speed is set to HIGH, that the fan filters are clean, and that the empty slots contain filler panels. For more information, refer to the ***Maintain Forced-Air Cooling Note to Users*** document available at [ni.com/docs](http://ni.com/docs).
- Keep relative humidity between 10% and 90%, noncondensing.
- Maintain an ambient temperature of  $23 \pm 5$  °C.
- Allow a warm-up time of at least 30 minutes after the chassis is powered on. The warm-up time ensures that the PXIe-5611 is at a stable operating temperature.



**Notice** Incorrect torque at SMA connections can degrade signal fidelity, PLL performance, and insertion loss. Use an SMA torque wrench or torque screwdriver to ensure all SMA connections are properly torqued to 1 N · m.

## Device Setup

1. Install the PXIe-5611 in the PXI Express chassis according to the instructions in the NI RF Signal Generators Getting Started Guide.
2. Configure the hardware using Measurement & Automation Explorer (MAX).
3. Launch the Calibration Executive procedure. Calibration Executive guides you through the required connections.

### Related concepts:

- [Launching a Calibration Procedure](#)

## PXIe-5644R/5646R Calibration Procedure

Calibrate the PXIe-5644R/5646R using Calibration Executive.

### Calibration Executive Procedure Features

Verify Only ✓	Adjust Only ✓	Verify & Adjust ✓	Manual Mode ✓	Optional Adjust ✗
---------------	---------------	-------------------	---------------	-------------------

### Approximate Test Time

Device	Verify Only	Adjust Only	Verify & Adjust
PXIe-5644R	56 minutes	80 minutes	200 minutes
PXIe-5646R	60 minutes	100 minutes	220 minutes



**Notice** Do not disconnect the cable that connects CAL IN to CAL OUT. Removing the cable from or tampering with the CAL IN or CAL OUT front panel connectors voids the product calibration, and specifications are no longer warranted.

### Test Equipment

The following table lists the test instruments required for calibrating the PXIe-5644R/5646R.

**Table 312.** Test equipment for calibrating the PXIe-5644R/5646R

Instrument	Recommended Model	Specification	Minimum Requirements	
Frequency reference	Symmetricom 8040 Rubidium Frequency Standard	Verifications: <ul style="list-style-type: none"> <li>• Internal frequency reference,</li> <li>• Nonharmonic spurs,</li> <li>• Spectral</li> </ul>	Frequency	10 MHz
			Frequency accuracy	$\pm 1E-9$



Instrument	Recommended Model	Specification	Minimum Requirements	
		<p>purity,</p> <ul style="list-style-type: none"> <li>• IMD3,</li> <li>• IMD2,</li> <li>• Output noise density,</li> <li>• Output second harmonics</li> </ul> <p>Adjustments:</p> <ul style="list-style-type: none"> <li>• Absolute amplitude accuracy,</li> <li>• Output power level accuracy</li> </ul>		
Power sensor	Rohde & Schwarz NRP-Z91 with NRP-Z4 USB adapter	<p>Verifications:</p> <ul style="list-style-type: none"> <li>• Absolute amplitude accuracy,</li> <li>• Frequency response,</li> <li>• Output power level accuracy,</li> <li>• LO OUT (RF IN 0 and RF OUT 0)</li> </ul> <p>Adjustments:</p> <ul style="list-style-type: none"> <li>• Absolute amplitude accuracy,</li> <li>• Output power level</li> </ul>	Range	-67 dBm to +23 dBm
			Frequency range	65 MHz to 6 GHz
			Accuracy	0.5%
			VSWR	<1.2 at 6 GHz

Instrument	Recommended Model	Specification	Minimum Requirements	
		accuracy, <ul style="list-style-type: none"> <li>• LO OUT (RF IN 0 and RF OUT 0)</li> </ul>		
Vector signal generator (Source 1)	PXIe-5673E (NI 5673)	Verifications: <ul style="list-style-type: none"> <li>• Internal frequency reference,</li> <li>• Absolute amplitude accuracy,</li> <li>• Frequency response,</li> <li>• Input nonharmonic spurs,</li> <li>• Input IMD3,</li> <li>• Input EVM,</li> <li>• Input IMD2</li> </ul> Adjustments: <ul style="list-style-type: none"> <li>• Internal frequency reference,</li> <li>• Absolute amplitude accuracy,</li> <li>• LO OUT (RF IN 0 and RF OUT 0)</li> </ul>	Frequency range	65 MHz to 6 GHz
			Frequency resolution	<5 Hz
			Amplitude range	-30 dBm to 0 dBm
			Instantaneous bandwidth	50 MHz
Spectrum analyzer or vector signal analyzer*	PXIe-5668 (NI 5668) or PXIe-5665 (NI 5665)	Verifications: <ul style="list-style-type: none"> <li>• Spectral purity,</li> </ul>	Frequency range	65 MHz to 6 GHz
			Noise floor at 6 GHz	<-158 dBm/Hz

Instrument	Recommended Model	Specification	Minimum Requirements	
		<ul style="list-style-type: none"> <li>• Output power level accuracy,</li> <li>• Output frequency response,</li> <li>• Output noise density,</li> <li>• Output second harmonics,</li> <li>• Output nonharmonic spurs,</li> <li>• Output IMD3,</li> <li>• Output EVM</li> </ul> <p>Adjustment:</p> <ul style="list-style-type: none"> <li>• Output power level accuracy</li> </ul>	Instantaneous bandwidth	50 MHz
			Phase noise at 20 kHz offset	<-125 dBm/Hz
Preamplifier	PXI-5691 (NI 5691)	Output noise density verification	Frequency range	65 MHz to 6 GHz
			Noise floor at 6 GHz	<-158 dBm/Hz
			Instantaneous bandwidth	50 MHz
			Phase noise at 20 kHz offset	<-125 dBm/Hz
Power splitter	Aeroflex/Weinschel 1593	<p>Verifications:</p> <ul style="list-style-type: none"> <li>• Frequency response,</li> <li>• Absolute</li> </ul>	VSWR	1.25 at 18 GHz
			Amplitude tracking	<0.25 dB

Instrument	Recommended Model	Specification	Minimum Requirements	
		amplitude accuracy, • Output power level accuracy  Adjustments: • Absolute amplitude accuracy, • Output power level accuracy		
6 dB attenuator (x2)	Anritsu 41KB-6 or Mini-Circuits	Verifications: • Frequency response, • Absolute amplitude accuracy, • Output power level accuracy  Adjustments: • Absolute amplitude accuracy, • Output power level accuracy	Frequency range	DC to 6 GHz
50 Ω SMA terminator	—	Average noise density	VSWR	1.1
			Frequency range	DC to 6 GHz

Instrument	Recommended Model	Specification	Minimum Requirements	
SMA (m)-to-SMA (m) cable	—	All	Frequency range	DC to 6 GHz
			Impedance	50 Ω
SMA (m)-to-N (f) adapter	Huber+Suhner 32_SMA_N-50-1/1-_UE	Verifications: <ul style="list-style-type: none"> <li>• Frequency response</li> <li>• Absolute amplitude accuracy,</li> <li>• Output power level accuracy,</li> <li>• LO OUT (FR IN 0 and RF OUT 0)</li> </ul> Adjustments: <ul style="list-style-type: none"> <li>• Absolute amplitude accuracy,</li> <li>• Output power level accuracy,</li> <li>• LO OUT (RF IN 0 and RF OUT 0)</li> </ul>	Frequency range	DC to 6 GHz
			Impedance	50 Ω
			Return loss	DC to 6 GHz ≥23 dB
SMA (f)-to-N (f) adapter	Huber+Suhner 31_N-SMA-50-1/1-_UE	All	Frequency range	DC to 6 GHz
			Impedance	50 Ω
			Return loss	DC to 6 GHz ≥23 dB
3.5 mm (m)-to-3.5 mm (m) adapter	Huber+Suhner 32_Pc35-50-0-2/199_NE	Verifications: <ul style="list-style-type: none"> <li>• Frequency</li> </ul>	Frequency range	DC to 6 GHz
			Impedance	50 Ω

Instrument	Recommended Model	Specification	Minimum Requirements	
		response, • Absolute amplitude accuracy, • Output power level accuracy  Adjustments:  • Absolute amplitude accuracy  Output power level accuracy	Return loss	DC to 6 GHz ≥30 dB



**Note** \*In Calibration Executive, the connection diagrams for the spectrum analyzer depict a PXIe-5665. Refer to the **PXIe-5668 Getting Started** documentation for connecting to and using the PXIe-5668.

## Test Conditions

The following setup and environmental conditions are required to ensure the PXIe-5644R/5646R meets published specifications.

- Keep cabling as short as possible. Long cables act as antennas, picking up extra noise that can affect measurements.
- Verify that all connections, including front panel connections and screws, are secure.
- Maintain an ambient temperature of  $23\text{ }^{\circ}\text{C} \pm 5\text{ }^{\circ}\text{C}$ .
- Keep the relative humidity between 10% and 90%, noncondensing.
- Allow a warm-up time of at least 30 minutes after the chassis is powered on and the Instrument Design Libraries are loaded and recognize the PXIe-5644R/5646R.

The warm-up time ensures that the PXIe-5644R/5646R and test instrumentation are at a stable operating temperature.

- Ensure that the PXI Express chassis fan speed is set to HIGH, that the fan filters (if present) are clean, and that the empty slots contain filler panels and slot blockers. For more information about chassis cooling, refer to the Maintain Forced-Air Cooling Note to Users document available at [ni.com/docs](http://ni.com/docs).

## Device Setup

1. Install the PXIe-5644R/5646R in the PXI Express chassis according to the instructions in the NI RF Signal Generators Getting Started Guide.
2. Configure the hardware using Measurement & Automation Explorer (MAX).
3. Launch the Calibration Executive procedure. Calibration Executive guides you through the required connections. Connection diagrams to the spectrum analyzer show connections to an NI 5665. Refer to the PXIe-5668 user manual for connections and usage of the preferred NI 5668.

## Test Limit Equations

The following test limits are derived from the published specifications.

**Table 257.** PXIe-5644R/5646R Test Limit Equations

Equation Type	Equation
Internal Frequency Reference Accuracy	$\text{TestLimits} = (\text{InitialAccuracy} + \text{TemperatureStability}) + \text{Aging}$

## PXIe-5645R Calibration Procedure

Calibrate the PXIe-5645R using Calibration Executive.

## Calibration Executive Procedure Features

Verify Only ✓	Adjust Only ✓	Verify & Adjust ✓	Manual Mode ✓	Optional Adjust ✓
---------------	---------------	-------------------	---------------	-------------------

## Approximate Test Time

Verify Only	Adjust Only	Verify & Adjust
90 minutes	120 minutes	300 minutes

## Test Equipment

The following tables list the test equipment required for calibrating PXIe-5645R modules.

**Table 312.** Test equipment for calibrating the PXIe-5645R

Instrument	Recommended Model	Where Used	Requirements
Frequency reference	Symmetricon 8040 Rubidium Frequency Standard	Verifications <ul style="list-style-type: none"> <li>• Internal frequency reference</li> <li>• Nonharmonic spurs</li> <li>• Spectral purity</li> <li>• IMD3</li> <li>• IMD2</li> <li>• Output noise density</li> <li>• Output second harmonics</li> </ul> Adjustments: <ul style="list-style-type: none"> <li>• Absolute amplitude accuracy</li> <li>• Output power level accuracy</li> </ul>	Frequency: 10 MHz Frequency accuracy: $\leq \pm 1E-9$ Output mode: sinusoid
(2x) Power	Rohde & Schwarz	Test RF and I/Q	Range: -67 dBm to +23 dBm



Instrument	Recommended Model	Where Used	Requirements
sensor	NRP-Z91 with NRP-Z4 USB adapter	<p>system characterization</p> <p>Verifications:</p> <ul style="list-style-type: none"> <li>• Absolute amplitude accuracy</li> <li>• Frequency response</li> <li>• Output power level accuracy</li> <li>• LO OUT (RF IN 0 and RF OUT 0)</li> <li>• I/Q verifications</li> </ul> <p>Adjustments:</p> <ul style="list-style-type: none"> <li>• Absolute amplitude accuracy</li> <li>• Output power level accuracy</li> <li>• LO OUT (RF IN 0 and RF OUT 0)</li> <li>• I/Q adjustments</li> </ul>	<p>Frequency range: 65 MHz to 6 GHz</p> <p>Accuracy: <math>\leq 0.5\%</math></p> <p>VSWR: <math>&lt; 1.2:1</math> at 6 GHz</p>
Vector signal generator	PXIe-5673E (NI 5673)	<p>Test system characterization</p> <p>Verifications</p> <ul style="list-style-type: none"> <li>• Internal frequency</li> </ul>	<p>Frequency range: 65 MHz to 6 GHz</p> <p>Frequency resolution: <math>&lt; 5</math> Hz</p> <p>Amplitude range: -70 dBm to 5 dBm</p> <p>Instantaneous bandwidth: 50 MHz</p>

Instrument	Recommended Model	Where Used	Requirements
		<p>reference</p> <ul style="list-style-type: none"> <li>• Absolute amplitude accuracy</li> <li>• Frequency response</li> <li>• Input nonharmonic spurs</li> <li>• Input IMD3</li> <li>• Input EVM</li> <li>• Input IMD2</li> </ul> <p>Adjustments:</p> <ul style="list-style-type: none"> <li>• Internal frequency reference</li> <li>• Absolute amplitude accuracy</li> <li>• LO OUT (RF IN 0 and RF OUT 0)</li> </ul>	
<p>Spectrum analyzer or vector signal analyzer *</p>	<p>PXIe-5668 (NI 5668) or PXIe-5665 (NI 5665)</p>	<p>Test system characterization</p> <p>Verifications:</p> <ul style="list-style-type: none"> <li>• Spectral purity</li> <li>• Output power level accuracy</li> <li>• Output frequency response</li> <li>• Output noise</li> </ul>	<p>Frequency range: 65 MHz to 12 GHz</p> <p>Instantaneous bandwidth: 50 MHz</p> <p>Phase noise at 20 kHz offset: &lt;-125 dBm/Hz</p>

Instrument	Recommended Model	Where Used	Requirements
		density <ul style="list-style-type: none"> <li>• Output second harmonics</li> <li>• Output nonharmonic spurs</li> <li>• Output IMD3</li> <li>• Output EVM</li> </ul> Adjustments: <ul style="list-style-type: none"> <li>• Output power level accuracy</li> </ul>	
Preamplifier	PXI-5691 (NI 5691)	Output noise density verification	Frequency range: 65 MHz to 12 GHz Noise floor at 6 GHz: <-158 dBm/Hz Instantaneous bandwidth: 50 MHz Phase noise at 20 kHz offset: <-125 dBm/Hz
(2x) calibration fixtures; one for verifications, one for adjustments	PXIe-5645R I/Q Calibration Fixture (calibration fixture), 782452-01	I/Q test system characterization I/Q verifications I/Q adjustments	—
Source measure unit (SMU)	PXI-4130 (NI 4130)	I/Q test system characterization I/Q verifications I/Q adjustments	DC voltage: 6 V DC current: 2A

Instrument	Recommended Model	Where Used	Requirements
Relay driver	PXI-2567 (NI 2567)	I/Q test system characterization I/Q verifications I/Q adjustments	—
DMM	PXI-4072 (NI 4072)	I/Q test system characterization I/Q verifications I/Q adjustments	Digits of precision: 6 1/2
Power splitter	Aeroflex/Weinschel 1593	Test system characterization Verifications: <ul style="list-style-type: none"> <li>• Frequency response</li> <li>• Absolute amplitude accuracy</li> <li>• Output power level accuracy</li> </ul> Adjustments: <ul style="list-style-type: none"> <li>• Absolute amplitude accuracy</li> <li>• Output power level accuracy</li> </ul>	VSWR: $\leq 1.25:1$ at 18 GHz Amplitude tracking: $< 0.25$ dB
(2x) 6 dB attenuators	Anritsu 41KB-6 or Mini-Circuits	Test system characterization	Frequency range: DC to 6 GHz

Instrument	Recommended Model	Where Used	Requirements
		<p>Verifications:</p> <ul style="list-style-type: none"> <li>• Frequency response</li> <li>• Absolute amplitude accuracy</li> <li>• Output power level accuracy</li> </ul> <p>Adjustments:</p> <ul style="list-style-type: none"> <li>• Absolute amplitude accuracy</li> <li>• Output power level accuracy</li> </ul>	<p>VSWR: <math>\leq 1.1:1</math></p>
50 $\Omega$ SMA terminator	—	<p>Test system characterization</p> <p>Average noise density verification</p>	<p>Frequency range: DC to 6 GHz</p> <p>VSWR: <math>\leq 1.1:1</math></p>
SMA (m)-to-SMA (m) cable	—	All procedures	<p>Frequency range: DC to 6 GHz</p> <p>Impedance: 50 <math>\Omega</math></p>
SMA (m)-to-N (f) adapter	Huber+Suhner 32_SMA_N-50-1/1_UE	<p>Test system characterization</p> <p>Verifications:</p> <ul style="list-style-type: none"> <li>• Frequency response</li> </ul>	<p>Frequency range: DC to 6 GHz</p> <p>Impedance: 50 <math>\Omega</math></p> <p>Return loss: <math>\geq 23</math> dB</p>

Instrument	Recommended Model	Where Used	Requirements
		<ul style="list-style-type: none"> <li>• Absolute amplitude accuracy</li> <li>• Output power level accuracy</li> <li>• LO OUT (RF IN 0 and RF OUT 0)</li> </ul> <p>Adjustments:</p> <ul style="list-style-type: none"> <li>• Absolute amplitude accuracy</li> <li>• Output power level accuracy</li> <li>• LO OUT (RF IN 0 and RF OUT 0)</li> </ul>	
SMA (f)-to-N (f) adapter	Huber+Suhner 31_N-SMA-50-1/1_UE	Test system characterization	<p>Frequency range: DC to 6 GHz</p> <p>Impedance: 50 Ω</p> <p>Return loss: ≥23 dB</p>
3.5 mm (m)-to-3.5 mm (m) adapter	Huber+Suhner 32_Pc35-50-0-2/199_NE	<p>Test system characterizations</p> <p>Verifications:</p> <ul style="list-style-type: none"> <li>• Frequency response</li> <li>• Absolute amplitude accuracy</li> </ul>	<p>Frequency range: DC to 6 GHz</p> <p>Impedance: 50 Ω</p> <p>Return loss: ≥30 dB</p>

Instrument	Recommended Model	Where Used	Requirements
		<ul style="list-style-type: none"> <li>• Output power level accuracy</li> </ul> <p>Adjustments:</p> <ul style="list-style-type: none"> <li>• Absolute amplitude accuracy</li> <li>• Output power level accuracy</li> </ul>	
(8x) MCX (m)-to-SMA (m) cables	188377-01	<p>I/Q test system characterization</p> <p>I/Q verifications</p> <p>I/Q adjustments</p>	<p>Frequency range: DC to 6 GHz</p> <p>Impedance: 50 Ω</p> <div style="border: 1px solid #ccc; padding: 5px; margin-top: 10px;">  <p><b>Note</b> All eight MCX cables used to connect the I/Q Calibration Fixture to the PXIe-5645 must be the same length and specifications, including any adapters used. If different cables are used, the API will report out-of-bounds errors during characterization.</p> </div>
78-pin DSUB cable	Included with relay driver module	<p>I/Q test system characterization</p> <p>I/Q verifications</p> <p>I/Q adjustments</p>	—
(2x) SMA (m)-to-N (f) adapter	Huber+Suhner 32_SMA_N-50-1/1-_UE	I/Q test system characterization	<p>Frequency range: DC to 6 GHz</p> <p>Impedance: 50 Ω</p>

Instrument	Recommended Model	Where Used	Requirements
		I/Q verifications I/Q adjustments	Return loss: $\geq 23$ dB
(3x) MCX terminations	Johnson Components 133-3801-801	I/Q test system characterization I/Q verifications I/Q adjustments	Impedance: 50 $\Omega$ Frequency range: DC to 1 GHz



**Note** \* In Calibration Executive, the connection diagrams for the spectrum analyzer depict a PXIe-5665. Refer to the PXIe-5668 Getting Started documentation for connecting to and using the PXIe-5668.

## Test Conditions

The following setup and environmental conditions are required to ensure the PXIe-5645R meets published specifications.

- Keep cabling as short as possible. Long cables and wires act as antennas, picking up extra noise that can affect measurements.
- Verify that all connections, including front panel connections and screws, are secure.
- Maintain an ambient temperature of  $23\text{ }^{\circ}\text{C} \pm 5\text{ }^{\circ}\text{C}$ .
- Keep relative humidity between 10% and 90%, noncondensing.
- Allow a warm-up time of at least 30 minutes after the chassis is powered on and the PXIe-5644R/5645R Instrument Design Libraries software is loaded and recognizes the PXIe-5645R. The warm-up time ensures that the PXIe-5645R and test instrumentation are at a stable operating temperature.
- Ensure that the chassis fan speed is set to HIGH, that the fan filters, if present, are clean, and that the empty slots contain filler panels. For more information about cooling, refer to the Maintain Forced-Air Cooling Note to Users document available at [ni.com/docs](http://ni.com/docs).



- Ensure the DMM has been self-calibrated according to manufacturer's specifications.



**Note** Do not connect power to the I/Q Calibration Fixture until you are ready to begin the I/Q portion of calibration. In addition, keep the I/Q fixture away from any heat sources such as your chassis.

## Device Setup

To set up the PXIe-5645R for calibration, complete the following steps:

1. Install the PXIe-5645R in the PXI Chassis according to the instructions in the NI PXIe-5645R Getting Started Guide.
2. Configure the hardware using Measurement & Automation Explorer (MAX). Refer to the Measurement & Automation Explorer Help for DAQ for more configuration information.
3. Launch the Calibration Executive procedure. Calibration Executive guides you through the required connections. Connection diagrams to the spectrum analyzer show connections to an NI 5665. Refer to the PXIe-5668 user manual for connections and usage of the preferred NI 5668.

## Test Limit Equations

The following test limits are derived from the published specifications.

**Table 259.** PXIe-5645R Test Limit Equations

Equation Type	Equation
Frequency Reference Accuracy	Limit = (Initial Value + Temperature Stability) + 1ppm * (# years since last adjustment)

## NI 5650/5651/5652 Calibration Procedure

Calibrate the NI PXI/PXIe-5650/5651/5652 using Calibration Executive.

## Calibration Executive Procedure Features

Verify Only ✓	Verify & Adjust ✓	Manual Mode ✓	Optional Adjust ✗
---------------	-------------------	---------------	-------------------

## Approximate Test Time

Verify Only	Adjust Only	Verify & Adjust
30 minutes	60 minutes	110 minutes



**Note** NI recommends performing adjustment every calibration cycle to ensure that the device is operating within specification. Devices must be adjusted prior to re-verification in order to reset the calibration cycle.

## Test Equipment

The following table lists the test instruments required for calibrating the NI 5650/5651/5652.

**Table 312.** Test equipment for calibrating the NI 5650/5651/5652

Instrument	Recommended Model	Requirements
Spectrum Analyzer	Rohde & Schwarz FSU Spectrum Analyzer with required options FSU-B23 (20 dB preamplifier) and FSU-B25 (electronic attenuator).	Frequency range: 500 kHz to 13.2 GHz  Noise floor: <-150 dBm/Hz
6 dB precision attenuator	Anritsu 41KB-6	Frequency range: 500 kHz to 6.6 GHz  Power rating: 2 W  Impedance: 50 Ω  VSWR: ≤1.1:1

Instrument	Recommended Model	Requirements
Power Meter	Anritsu ML2438A with an Anritsu Sc7400 thermal sensor	Range: -55 dBm to 20 dBm Frequency range: 100 kHz to 18 GHz
Frequency Reference	Symmetricon 8040C Rubidium Frequency Standard	Frequency: 10 MHz Frequency Accuracy: $\leq \pm 1E-9$
BNC (m)-to-BNC (m) cable	Pomona 5697	—
SMA (m)-to-BNC (m) cable	Pasternack Enterprises Pe3696-36	—
SMA (m)-to-SMA (m) cable	MegaPhase G916-S1S1-36	Frequency range: DC to 6.6 GHz Insertion loss: $\leq 1.2$ dB at 6.6 GHz Impedance: 50 $\Omega$ VSWR: $\leq 1.25 : 1$ at 6.6 GHz
N (m)-to-SMA (f) adapter	Radiall R191.329.000	Frequency range: DC to 11 GHz Impedance: 50 $\Omega$
SMA Torque Wrench	NI RF Torque Wrench	1 N · m
PXI Express Chassis	PXIe-1065 or PXIe-1075	—



**Note** NI strongly recommends using the instruments specified above when calibrating the NI 5650/5651/5652 module. Substitution of instruments is permitted by Calibration Executive software, but NI cannot guarantee that unsupported instruments meet the specifications required for calibration.

## Test Conditions

The following setup and environmental conditions are required to ensure the NI 5650/5651/5652 meets published specifications.

- Keep cabling as short as possible. Long cables act as antennas, picking up extra noise that can affect measurements.
- Verify that all connections, including front panel connections and screws, are secure.
- Ensure that the PXI chassis fan speed is set to HIGH, that the fan filters are clean, and that the empty slots contain filler panels. For more information, refer to the ***Maintain Forced-Air Cooling Note to Users*** document available at [ni.com/docs](http://ni.com/docs).
- Keep relative humidity between 10% and 90%, noncondensing.
- Maintain an ambient temperature of  $23\text{ }^{\circ}\text{C} \pm 5\text{ }^{\circ}\text{C}$ .
- Allow a warm-up time of at least 30 minutes after the chassis is powered on. The warm-up time ensures that the NI 5650/5651/5652 is at a stable operating temperature.



**Notice** Incorrect torque at SMA connections can degrade signal fidelity, PLL performance, and insertion loss. Use an SMA torque wrench or torque screwdriver to ensure all SMA connections are properly torqued to  $1\text{ N} \cdot \text{m}$ .

## Device Setup

1. Install the NI 5650/5651/5652 in the PXI chassis according to the instructions in the NI RF Signal Generators Getting Started Guide.
2. Configure the hardware using Measurement & Automation Explorer (MAX).
3. Launch the Calibration Executive procedure. Calibration Executive guides you through the required connections.

## Understanding Validate ALC Limits Table Results

During the calibration procedure, the 565x ALC Limits Table is validated to ensure the device is operating properly. Validation consists of two test cases:

- ALC Limits Table Present
- ALC Limits Validation

ALC Limits Table Present verifies that the ALC Limits Table is present on the device EEPROM. A failure of this test indicates that the ALC Limits Table is not present and that the NI 565x device requires adjustment to populate the table.

ALC Limits Validation validates the data in the ALC Limits Table. If the ALC Limits Table is present but the validation test fails, then the device specifications are not warranted over temperature at these limits. If this test continues to fail after adjustment, the NI 565x device requires repair.

## Test Limit Equations

Refer to published NI PXI-5650/5651/5652 Specifications or NI PXIe-5650/5651/5652 Specifications for detailed specifications and test limit equations.

### Related concepts:

- [Launching a Calibration Procedure](#)

## PXIe-5653 Calibration Procedure

Calibrate the PXIe-5653 using Calibration Executive.

### Calibration Executive Procedure Features

Verify Only ✓	Verify & Adjust ✓	Manual Mode ✓	Optional Adjust ✗
---------------	-------------------	---------------	-------------------

## Approximate Test Time

Verify	Verify & Adjust
25 minutes	60 minutes

## Test Equipment

The following table lists the test instruments required for calibrating the PXIe-5653.

**Table 312.** Test equipment for calibrating the PXIe-5653

Instrument	Recommended Model	Specification	Minimum Requirements	
Signal source analyzer	Rohde & Schwarz FSUP Signal Source Analyzer	Verifications: <ul style="list-style-type: none"> <li>• 10 MHz reference frequency accuracy,</li> <li>• 100 MHz reference frequency accuracy,</li> <li>• Lo1 frequency accuracy,</li> <li>• Lo1 phase noise,</li> <li>• Lo2 phase noise,</li> <li>• Lo3 phase noise</li> </ul> Adjustments: <ul style="list-style-type: none"> <li>• Reference accuracy,</li> <li>• YIG frequency accuracy</li> </ul>	Frequency range	9 MHz to 10 GHz
			Frequency accuracy	1 ppb over the frequency range 900 MHz to 9 GHz
			Noise floor	<-152 dBm/Hz
			Phase noise measurement using cross-correlation	
			Frequency counter marker	
			Spectrum analysis capabilities	
Frequency reference	Symmetricom 8040C Rubidium Frequency Standard	Verifications: <ul style="list-style-type: none"> <li>• 10 MHz</li> </ul>	Frequency	10 MHz
			Frequency accuracy	$\pm 1E-9$

Instrument	Recommended Model	Specification	Minimum Requirements	
		reference frequency accuracy, • 100 MHz reference frequency accuracy, • Lo1 frequency accuracy  Adjustments:  • Reference accuracy, • YIG frequency accuracy		
Power meter	Anritsu ML2438A with a MA247xD Series Diode Sensor	Verifications:  • 10 MHz reference amplitude accuracy, • 100 MHz reference amplitude accuracy, • Lo1 amplitude accuracy, • Lo2 amplitude accuracy, • Lo3 amplitude accuracy  Adjustments:  • Lo1, Lo2, and Lo3 output power	Range	0 dBm to +20 dBm
			Frequency range	9 MHz to 8.3 GHz
			Accuracy	0.5%
			Linearity	Up to +15 dBm (Ma2475 only)

Instrument	Recommended Model	Specification	Minimum Requirements	
SMA (m)-to-SMA (m) cable	—	Verifications: <ul style="list-style-type: none"> <li>• 10 MHz reference amplitude accuracy,</li> <li>• 100 MHz reference amplitude accuracy,</li> <li>• Lo1 frequency accuracy,</li> <li>• Lo1 phase noise,</li> <li>• Lo2 phase noise,</li> <li>• Lo3 phase noise</li> </ul> Adjustments: <ul style="list-style-type: none"> <li>• Reference accuracy,</li> <li>• YIG frequency accuracy,</li> <li>• Lo1, Lo2, and Lo3 output power</li> </ul>	Length	36 in



**Note** If using a Rohde & Schwarz FSUP as one of the standards, select it as both **Spectrum Analyzer** and **Signal Source Analyzer**. If not, select **Unsupported Instrument** for the **Signal Source Analyzer**.

## Test Conditions

The following setup and environmental conditions are required to ensure the PXIe-5653 meets published specifications.

- Keep cabling as short as possible. Long cables act as antennas, picking up extra



noise that can affect measurements.

- Verify that all connections, including front panel connections and screws, are secure.
- Maintain an ambient temperature of  $23\text{ }^{\circ}\text{C} \pm 5\text{ }^{\circ}\text{C}$ .
- Keep the relative humidity between 10% and 90%, noncondensing.
- Allow a warm-up time of at least 30 minutes after the chassis is powered on. The warm-up time ensures that the PXIe-5653 is at a stable operating temperature.
- Plug the PXI/PXI Express chassis and the calibrator into the same power strip to avoid ground loops.
- Use a torque wrench appropriate for the type of RF connector that you are using. NI recommends a  $0.565\text{ N}\cdot\text{m}$  (5 lb·in.) wrench for SMA connectors and an  $0.90\text{ N}\cdot\text{m}$  (8 lb·in.) wrench for 3.5 mm connectors.
- Connect the frequency reference source to the REF IN connector on the back of the PXI Express chassis with a standard BNC (m)-to BNC (m) cable. This connection replaces the connection from the PXIe-5653 REF OUT (10 MHz) connector to the PXI Express chassis REF IN connector, if present.
- Ensure that the PXI Express chassis fan speed is set to HIGH, that the fan filters are clean, and that the empty slots contain filler panels. For more information, refer to the ***Maintain Forced-Air Cooling Note to Users*** document available at [ni.com/docs](http://ni.com/docs).

## Test Limit Equations

The following test limits are derived from the published specifications.

**Table 262.** PXIe-5653 Test Limit Equations

Equation Type	Equation
Reference Frequency Accuracy	$\text{TestLimits} = \text{TestValue} \pm (\text{InitialAccuracy} + \text{Aging} + \text{TemperatureStability})$ <ul style="list-style-type: none"> <li>• InitialAccuracy = 50 ppb</li> <li>• Aging = 100 ppb/year</li> <li>• TemperatureStability = 10 ppb</li> </ul> <p>As-found: 260 ppb</p> <p>As-left: 60 ppb</p>

## PXIe-5654 Calibration Procedure

Calibrate the National Instruments PXIe-5654 using Calibration Executive in a 64-bit Windows environment.

### Calibration Executive Procedure Features

Verify Only ✓	Verify & Adjust ✓	Manual Mode ✗	Optional Adjust ✗
---------------	-------------------	---------------	-------------------

### Approximate Test Time

Device	Verify Only	Adjust Only	Verify & Adjust
PXIe-5654 (20 GHz)	12 minutes	53 minutes	72 minutes
PXIe-5654 (10 GHz)	10 minutes	43 minutes	58 minutes

All devices require a 30-minute warmup period, which is not included in the test time estimates.

### Test Equipment

The following table lists the test equipment required for calibrating the PXIe-5654 module.

**Table 312.** Test equipment for calibrating the PXIe-5654

Instrument	Recommended Model	Where Used	Requirements
Signal source analyzer	Rohde & Schwarz FSUP26 Signal Source Analyzer	Verifications: <ul style="list-style-type: none"> <li>• 10 MHz reference amplitude accuracy</li> <li>• 100 MHz reference amplitude accuracy</li> <li>• RF OUT frequency accuracy</li> <li>• RF OUT phase noise</li> <li>• PULSE IN operation</li> </ul>	Frequency range: 0.25 MHz to 20 GHz Frequency counter resolution: 0.1 Hz Phase noise measurement using cross-correlation Frequency counter marker feature

Instrument	Recommended Model	Where Used	Requirements
		Adjustments: <ul style="list-style-type: none"> <li>• Frequency reference accuracy</li> </ul>	Spectrum analysis capabilities
Frequency reference	Symmetricon 8040C Rubidium Frequency Standard	Verifications: <ul style="list-style-type: none"> <li>• 10 MHz reference amplitude accuracy</li> <li>• 100 MHz reference amplitude accuracy</li> <li>• RF OUT frequency accuracy</li> </ul> Adjustments: <ul style="list-style-type: none"> <li>• Frequency reference accuracy</li> </ul>	Frequency: 10 MHz Frequency accuracy: $\pm 1 \times 10^{-9}$
Power meter	Anritsu ML2438A	Verifications: <ul style="list-style-type: none"> <li>• 10 MHz reference amplitude accuracy</li> <li>• 100 MHz reference amplitude accuracy</li> <li>• RF OUT amplitude accuracy</li> <li>• RF OUT maximum power</li> <li>• RF OUT minimum power</li> </ul> Adjustments: <ul style="list-style-type: none"> <li>• RF OUT power</li> </ul>	Frequency range: 250 kHz to 20.8 GHz Dynamic range: -15 dBm to +20 dBm Accuracy: $< \pm 4.0\%$
Power sensor	Anritsu SC7413A	Verifications: <ul style="list-style-type: none"> <li>• 10 MHz reference</li> </ul>	Frequency range: 250 kHz to 20.8 GHz

Instrument	Recommended Model	Where Used	Requirements
		amplitude accuracy <ul style="list-style-type: none"> <li>• 100 MHz reference amplitude accuracy</li> <li>• RF OUT amplitude accuracy</li> <li>• RF OUT maximum power</li> <li>• RF OUT minimum power</li> </ul> Adjustments: <ul style="list-style-type: none"> <li>• RF OUT power</li> </ul>	Dynamic range: -15 dBm to +20 dBm  VSWR: <1.04, 100 KHz to 10 MHz <1.17, 10 MHz to 150 MHz <1.08, 150 MHz to 2 GHz <1.16, 2 GHz to 12.4 GHz <1.21, 12.4 GHz to 18 GHz <1.29, 18 GHz to 20.8 GHz  Accuracy: $\leq 4\%$
K(m)-to-K(m) cable	Florida RF Labs KMS-160-36.0-KMS	Verifications: <ul style="list-style-type: none"> <li>• RF OUT frequency accuracy</li> <li>• RF OUT phase noise</li> </ul> Adjustments: <ul style="list-style-type: none"> <li>• Frequency reference accuracy</li> </ul>	Length: 36 in.  Loss: <0.7 dB/ft. (typical) at 20 GHz  Impedance: 50 $\Omega$

## Test Conditions

The following setup and environmental conditions are required to ensure the PXIe-5654 meets published specifications.

- Keep connections to the device short. Long cables and wires act as antennas, picking up noise that can affect measurements.

- Verify that all connections to the module, including front panel connections and screws, are secure.
- Keep relative humidity between 10% and 90% noncondensing.
- Maintain an ambient temperature of  $23\text{ °C} \pm 5\text{ °C}$ .
- Allow a warm-up time of at least 30 minutes after powering on all hardware, loading the operating system, and, if necessary, enabling the device. Unless manually disabled, the NI-RFSG driver automatically loads with the operating system and enables the device. The warm-up time brings the measurement circuitry of the device to a stable operating temperature.
- Use an appropriate torque wrench to tighten all module RF connectors (SMA, 3.5 mm, or K). NI recommends a  $0.565\text{ N} \cdot \text{m}$  (5 lb · in.) wrench for SMA connectors and a  $0.90\text{ N} \cdot \text{m}$  (8 lb · in.) wrench for 3.5 mm or K connectors.
- Connect the frequency reference source to the signal source analyzer REF IN back panel connector using a BNC(m)-to-BNC(m) cable, and connect the signal source analyzer REF OUT connector to the module's REF IN connector using a BNC(m)-to-SMA(m) cable.
- Ensure that the PXI Express chassis fan speed is set to HI, that the fan filters, if included, are clean, and that the empty slots contain filler panels.
- Plug the PXI Express chassis and the calibrator into the same power strip to avoid ground loops.



**Note** The PXIe-5654 Calibration Procedure is supported only in a 64-bit Windows environment.



**Note** Frequencies less than and equal to 10 GHz apply to both the 10 GHz and 20 GHz variants; frequencies above 10 GHz apply only to the 20 GHz module.

## Device Setup

1. Install the modules in the PXI Express chassis according to the instructions in the PXIe-5654 Getting Started Guide.
2. Configure the hardware using Measurement & Automation Explorer (MAX).
3. Launch the Calibration Executive procedure and complete the setup wizard.

## Test Limit Equations

Table 268. PXIe-5654 Test Limit Equations

Equation Type	Equation
Frequency Accuracy	<p>As-left Calculation: Initial Accuracy + Temperature Stability</p> <p>As-found Calculation: Initial Accuracy + Aging + Temperature Stability</p> <ul style="list-style-type: none"> <li>• where           <ul style="list-style-type: none"> <li>◦ Initial Accuracy = <math>\pm 0.1</math> ppm</li> <li>◦ Temperature Stability (15 °C to 35 °C) = <math>\pm 0.2</math> ppm</li> <li>◦ 10-year aging = 1.25 ppm</li> </ul> </li> </ul>

### Related concepts:

- [Launching a Calibration Procedure](#)

## PXIe-5654 with PXIe-5696 Calibration Procedure

Calibrate the PXIe-5654 when you use it with the PXIe-5696 using Calibration Executive in a Windows 64-bit environment.

### Calibration Executive Procedure Features

Verify Only ✓	Verify & Adjust ✓	Manual Mode ✗	Optional Adjust ✗
---------------	-------------------	---------------	-------------------

### Approximate Test Time

Device	Verify Only	Adjust Only	Verify & Adjust
PXIe-5654 (20 GHz)	23 minutes	97 minutes	135 minutes
PXIe-5654 (10 GHz)	19 minutes	87 minutes	Unsupported

All devices require a 30-minute warmup period, which is not included in the test time estimates.

## Test Equipment

The following table lists the test equipment required for calibrating the PXIe-5654/PXIe-5696 system.

**Table 312.** Test equipment for calibrating the PXIe-5654/PXIe-5696 system

Instrument	Recommended Model	Where Used	Requirements
Signal generator *	PXIe-5654 20 GHz variant	—	Adjustment
Signal source analyzer	Rohde & Schwarz FSUP26 Signal Source Analyzer	Verifications: <ul style="list-style-type: none"> <li>RF OUT frequency accuracy</li> <li>RF OUT phase noise</li> <li>RF OUT amplitude accuracy</li> <li>RF OUT maximum power</li> <li>PULSE IN operation</li> </ul> Adjustments: <ul style="list-style-type: none"> <li>Frequency reference accuracy</li> </ul>	Frequency range: 0.25 MHz to 20 GHz Frequency counter resolution: 0.1 Hz Phase noise measurement using cross-correlation Frequency counter marker feature Spectrum analysis capabilities
Frequency reference	Symmetricon 8040C Rubidium Frequency Standard	Verifications: <ul style="list-style-type: none"> <li>RF OUT frequency accuracy</li> <li>RF OUT maximum power</li> <li>PULSE IN operation</li> </ul> Adjustments: <ul style="list-style-type: none"> <li>Frequency</li> </ul>	Frequency: 10 MHz Frequency accuracy: $\pm 1 \times 10^{-9}$

Instrument	Recommended Model	Where Used	Requirements
		reference accuracy	
Power meter	Anritsu ML2438A	Verifications: <ul style="list-style-type: none"> <li>• RF OUT amplitude accuracy</li> <li>• RF OUT maximum power</li> </ul> Adjustments: <ul style="list-style-type: none"> <li>• RF OUT power</li> <li>• RF attenuator accuracy</li> <li>• Amplitude accuracy (low harmonic paths)</li> <li>• Amplitude accuracy (high power paths)</li> <li>• Automatic Level Control (ALC)</li> </ul>	Frequency range: 250 kHz to 20.8 GHz  Dynamic range: -40 dBm to +20 dBm  Accuracy: < ±4.0%
Power sensor <sup>†</sup>	Anritsu SC7413A	Verifications: <ul style="list-style-type: none"> <li>• 10 MHz reference amplitude accuracy</li> <li>• 100 MHz reference amplitude accuracy</li> <li>• RF OUT amplitude accuracy</li> <li>• RF OUT maximum power</li> <li>• RF OUT minimum power</li> </ul> Adjustments:	Frequency range: 250 kHz to 20.8 GHz  Dynamic range: -40 dBm to +20 dBm  VSWR: <ul style="list-style-type: none"> <li>&lt;1.04, 100 KHz to 10 MHz</li> <li>&lt;1.17, 10 MHz to 150 MHz</li> <li>&lt;1.08, 150 MHz to 2 GHz</li> <li>&lt;1.16, 2 GHz to 12.4 GHz</li> <li>&lt;1.21, 12.4 GHz to 18 GHz</li> </ul>



Instrument	Recommended Model	Where Used	Requirements
		<ul style="list-style-type: none"> <li>RF OUT power</li> </ul>	<p>&lt;1.29, 18 GHz to 20.8 GHz</p> <p>Accuracy: <math>\leq 4\%</math></p>
K(m)-to-K(m) cable (x2)	Florida RF Labs KMS-160-36.0-KMS	<p>Verifications:</p> <ul style="list-style-type: none"> <li>RF OUT frequency accuracy</li> <li>RF OUT phase noise</li> <li>RF OUT amplitude accuracy</li> </ul> <p>Adjustments:</p> <ul style="list-style-type: none"> <li>Frequency reference accuracy</li> </ul>	<p>Length: 36 in.</p> <p>Loss: &lt;0.7 dB/ft. (typical) at 20 GHz</p> <p>Impedance: 50 <math>\Omega</math></p>
K(m)-to-K(m) cable (x2)	Florida RF Labs KMS-160-12.0-KMS	<p>Verifications:</p> <ul style="list-style-type: none"> <li>RF OUT amplitude accuracy</li> <li>RF OUT maximum power</li> </ul> <p>Adjustments:</p> <ul style="list-style-type: none"> <li>RF attenuator path</li> </ul>	<p>Length: 12 in.</p> <p>Loss: &lt;0.5 dB/ft. (typical) at 20 GHz</p> <p>Impedance: 50 <math>\Omega</math></p>
K(m)-to-K(f) 20 dB attenuator	Anritsu 41KB-20	<p>Adjustments:</p> <ul style="list-style-type: none"> <li>RF attenuator path</li> </ul>	<p>Frequency range: DC to 20 GHz</p> <p>VSWR: &lt;1.18</p> <p>Accuracy: <math>\leq \pm 0.5</math> dB</p> <p>Impedance: 50 <math>\Omega</math></p>

Instrument	Recommended Model	Where Used	Requirements
K(m)-to-K(f) 6 dB attenuator (x2)	Anritsu 41KB-6	Test system verification  Verifications: <ul style="list-style-type: none"> <li>RF OUT amplitude accuracy</li> <li>RF OUT maximum power</li> </ul>	Frequency range: DC to 20 GHz  VSWR: <1.18  Accuracy: $\leq \pm 0.5$ dB  Impedance: 50 $\Omega$
Power splitter	Aeroflex/Weinschel 1593	Test system verification  Verifications: <ul style="list-style-type: none"> <li>RF OUT amplitude accuracy</li> <li>RF OUT maximum power</li> </ul>	Frequency range: DC to 20 GHz  VSWR: <1.35  Insertion loss: <8.5 dB  Impedance: 50 $\Omega$



### Note

- \* The PXIe-5654 20 GHz standard is required to adjust a PXIe-5654 10 GHz module as DUT.
- † NI recommends that, while using Calibration Executive, you do not use an adapter to extend the power sensor connection.

## Test Conditions

The following setup and environmental conditions are required to ensure the PXIe-5654 and PXIe-5696 meet published specifications.

- Keep connections to the device short. Long cables and wires act as antennas, picking up noise that can affect measurements.
- Verify that all connections to the PXIe-5654 and PXIe-5696 modules, including front panel connections and screws, are secure.
- Keep relative humidity between 10% and 90% noncondensing.

- Maintain an ambient temperature of  $23\text{ }^{\circ}\text{C} \pm 5\text{ }^{\circ}\text{C}$ .
- Allow a warm-up time of at least 30 minutes after powering on all hardware, loading the operating system, and, if necessary, enabling the device. Unless manually disabled, the NI-RFSG driver automatically loads with the operating system and enables the device. The warm-up time brings the measurement circuitry of the devices to a stable operating temperature.
- Use an appropriate torque wrench to tighten all module RF connectors (SMA, 3.5 mm, or K). NI recommends a  $0.565\text{ N}\cdot\text{m}$  ( $5\text{ lb}\cdot\text{in.}$ ) wrench for SMA connectors and a  $0.90\text{ N}\cdot\text{m}$  ( $8\text{ lb}\cdot\text{in.}$ ) wrench for 3.5 mm or K connectors.
- Connect the frequency reference source to the signal source analyzer REF IN back panel connector using a BNC(m)-to-BNC(m) cable, and connect the signal source analyzer REF OUT connector to the module's REF IN connector using a BNC(m)-to-SMA(m) cable.
- Ensure that the PXI Express chassis fan speed is set to HI, that the fan filters, if included, are clean, and that the empty slots contain filler panels.
- Plug the PXI Express chassis and the calibrator into the same power strip to avoid ground loops.
- Frequencies less than and equal to 10 GHz apply to the 10 GHz and 20 GHz PXIe-5654 module; frequencies above 10 GHz apply only to the 20 GHz PXIe-5654.
- The PXIe-5654 must be verified as a stand-alone device using the PXIe-5654 Calibration Procedure before performing this procedure.



**Note** Do not disconnect the rigid cable on the PXIe-5696 connecting RF AMP OUT to ATTN IN. This cable must be in place before calibration; disconnect the cable only during an adjustment procedure, when prompted by Calibration Executive.



**Note** The PXIe-5654 with PXIe-5696 Calibration Procedure is supported only in a 64-bit Windows environment.



**Note** Frequencies less than and equal to 10 GHz apply to both the 10 GHz and 20 GHz variants; frequencies above 10 GHz apply only to the 20 GHz module.

## Device Setup

1. Install the modules in the PXI Express chassis according to the instructions in the PXIe-5654 Getting Started Guide and the PXIe-5696 Getting Started Guide.
2. Configure the hardware using Measurement & Automation Explorer (MAX).
3. Launch the Calibration Executive procedure and complete the setup wizard.

## Calibrating the 10 GHz Variant

To verify and adjust the PXIe-5654 10 GHz signal generator with the PXIe-5696 amplitude extender, you must run verify only (VO) and adjust only (AO) procedures separately (VO + AO + VO). A PXIe-5654 20 GHz variant is a required standard to run the adjustment procedure.

Perform the following steps to verify and adjust the PXIe-5654 10 GHz module with the PXIe-5696.

1. With the PXIe-5654 10 GHz DUT and the PXIe-5696 module installed in the chassis, run the **Verify Only** procedure.
2. When the verification procedure has completed, power down the host computer.
3. Install the PXIe-5654 20 GHz module in the chassis slot adjacent to and on the left side of the PXIe-5696.



**Note** The PXIe-5654 10 GHz DUT must remain present in the chassis for the adjustment but can change slots to accommodate the standard, which must be installed in the slot just to the left of the PXIe-5696

4. Connect the PXIe-5654 20 GHz standard to the PXIe-5696 module.
5. With the three modules installed in the chassis, run the **Adjust Only** procedure.
6. When the adjustment procedure has completed, power down the host computer.
7. Remove the PXIe-5654 20 GHz standard from the chassis, and connect the PXIe-5654 10 GHz DUT to the PXIe-5696.
8. Run the **Verify Only** procedure again to verify results for the as-left status.

## Test Limit Equations

Table 266. PXIe-5654 with PXIe-5696 Test Limit Equations

Equation Type	Equation
Frequency Accuracy	<p>As-left Calculation: Initial Accuracy + Temperature Stability</p> <p>As-found Calculation: Initial Accuracy + Aging + Temperature Stability</p> <ul style="list-style-type: none"> <li>• where           <ul style="list-style-type: none"> <li>◦ Initial Accuracy = <math>\pm 0.1</math> ppm</li> <li>◦ Temperature Stability (15 °C to 35 °C) = <math>\pm 0.2</math> ppm</li> <li>◦ 10-year aging = 1.25 ppm</li> </ul> </li> </ul>

### Related concepts:

- [Launching a Calibration Procedure](#)

## PXIe-5655 Calibration Procedure

Calibrate the PXIe-5655 using Calibration Executive. This procedure supports PXIe-5655 variants with SMA or MMPX connection types.

### Calibration Executive Procedure Features

Verify Only ✓	Verify & Adjust ✓	Manual Mode ✓	Optional Adjust ⓧ
---------------	-------------------	---------------	-------------------

### Approximate Test Time

Warm Up	Verify Only	Adjust Only	Verify & Adjust
30 minutes	5 minutes	85 minutes	95 minutes

All devices require a 30-minute warmup period, which is not included in the test time estimates.

## Test Equipment

The following table lists the test equipment required for calibrating the PXIe-5655.

**Table 312.** Test equipment for calibrating the PXIe-5655

Instrument	Recommended Model	Where Used	Requirements
Signal source analyzer	Rohde & Schwarz FSWP26 Signal Source Analyzer (PLL and Cross-Correlation)	Verifications: <ul style="list-style-type: none"> <li>• Spectral purity</li> <li>• Internal frequency accuracy</li> </ul> Adjustments: <ul style="list-style-type: none"> <li>• Spectral purity</li> <li>• Frequency reference RF Out</li> </ul>	Functions: <ul style="list-style-type: none"> <li>• Frequency range: 50 MHz to 7.2 GHz</li> <li>• Frequency counter resolution: 0.1 Hz</li> <li>• Phase noise measurement using cross-correlation</li> <li>• Frequency counter marker feature</li> <li>• Spectrum analysis capabilities</li> </ul>
Frequency reference	Symmetricon 8040C Rubidium Frequency Standard	Verifications: <ul style="list-style-type: none"> <li>• Spectral purity</li> <li>• Internal frequency accuracy</li> </ul> Adjustments: <ul style="list-style-type: none"> <li>• Spectral purity</li> <li>• Frequency reference RF Out</li> </ul>	Frequency accuracy: $\leq \pm 1 \times 10^{-9}$ (Stability after warm-up)
Power sensor	Rohde & Schwarz NRP33S 3.5 mm (USB)	Verification: <ul style="list-style-type: none"> <li>• Amplitude</li> </ul>	Absolute power measurement accuracy should not exceed 0.15 dB including mismatch and linearity.

Instrument	Recommended Model	Where Used	Requirements
		<p>accuracy</p> <p>Adjustment:</p> <ul style="list-style-type: none"> <li>• Amplitude accuracy</li> </ul>	
RF SMA (m)-to-SMA (m) cable	Any brand	<p>Verifications:</p> <ul style="list-style-type: none"> <li>• Spectral purity</li> <li>• Internal frequency accuracy</li> </ul> <p>Adjustments:</p> <ul style="list-style-type: none"> <li>• Spectral purity</li> <li>• Frequency reference RF Out</li> </ul>	Used for connecting the FSWP26 to the DUT. Must be a precision grade cable.
BNC (m)-to-BNC (m) cable	Any brand	<p>Verifications:</p> <ul style="list-style-type: none"> <li>• Spectral purity</li> <li>• Internal frequency accuracy</li> </ul> <p>Adjustments:</p> <ul style="list-style-type: none"> <li>• Spectral purity</li> <li>• Frequency reference RF Out</li> </ul>	Used for 10 MHz clock signal
SMA (m)-	Huber+Suhner 33_SMA-	Verifications:	

Instrument	Recommended Model	Where Used	Requirements
to-N-Type (f) adapter	N-50-51/1--_UE	<ul style="list-style-type: none"> <li>• Spectral purity</li> <li>• Internal frequency accuracy</li> </ul> <p>Adjustments:</p> <ul style="list-style-type: none"> <li>• Spectral purity</li> <li>• Frequency reference RF Out</li> </ul>	
MMPX (m)-to-SMA (f) adapter	Huber+Suhner 33_MMPX-SK-50-1/199_N	<p>Verifications:</p> <ul style="list-style-type: none"> <li>• Amplitude accuracy</li> </ul> <p>Adjustments:</p> <ul style="list-style-type: none"> <li>• Amplitude accuracy</li> </ul>	For DUT with MMPX connectors
3.5 mm (m)-to-3.5 mm (f) adapter	Huber+Suhner 33_PC35-50-0-2/199_NE	<p>Verifications:</p> <ul style="list-style-type: none"> <li>• Amplitude accuracy</li> </ul> <p>Adjustments:</p> <ul style="list-style-type: none"> <li>• Amplitude accuracy</li> </ul>	For DUT with SMA connectors
3.5 mm (f)-to-3.5 mm (f) adapter	Maury Microwave CC-A-35-FF	<p>Verifications:</p> <ul style="list-style-type: none"> <li>• Frequency accuracy</li> <li>• Phase</li> </ul>	Used to convert the FSWP 3.5 mm (m) connector to a 3.5 mm (f) connector. Required for 3.5 mm (m) cables.



Instrument	Recommended Model	Where Used	Requirements
		noise  Adjustments:  <ul style="list-style-type: none"> <li>• Frequency accuracy</li> </ul>	

## Test Conditions

The following setup and environmental conditions are required to ensure the PXIe-5655 meets published specifications.

- Keep cabling as short as possible. Long cables act as antennas, picking up extra noise that can affect measurements.
- Ensure that all connections to the DUT are secure.
- Allow adequate Warm-Up time for all components of the calibration system.
- Make all connections as shown in diagrams.
- Use shielded copper wire for all cable connections to the DUT.
- Use twisted-pair wires to eliminate noise and thermal offsets.
- Ensure that the PXI/PXI Express chassis fan speed is set to HIGH, that the fan filters are clean, and that the empty slots contain filler panels. For more information, refer to the ***Maintain Forced-Air Cooling Note to Users*** document available at [ni.com/docs](http://ni.com/docs).
- If a DUT fails reverification after adjustment, ensure that the Test Conditions have been met before returning the DUT to NI.
- Locate a lab jack for supporting power sensor connection to the PXIe-5655 test port. The power sensor might cause strain on the PXIe-5655 test port connector due to tight spacing between the chassis and the DUT. Exercise care when making a connection.
- Coaxial connectors used in this procedure are mechanically compatible. Using adapters to convert between different families of connectors may be unavoidable but should be minimized. Adapters should convert directly and not be stacked. Also be wary of mating between dissimilar connectors. For example, APC-3.5 and SMA look very similar but have different mechanical interfaces. The use of a precision adapter or connection saver is recommended between APC-3.5 and SMA

connectors.

- Use a torque wrench for consistency and apply appropriate torque values. When tightening screw-type connectors, use a torque wrench to avoid over- or under-tightening the connector. This will ensure there is little variation in tightness when another operator takes over.
- Inspect, clean, and gauge the pin depth before using any coaxial connectors or cables. Recess might reduce electrical performance. Protrusion would damage the connectors.

## Device Setup

1. Install the modules in the PXI Express chassis. Refer to ***Installing the PXIe-5841*** and ***Connecting the PXIe-5655 Analog Signal Generator to the PXIe-5841*** in the ***PXIe-5841 Getting Started Guide***.
2. Configure the hardware using Measurement & Automation Explorer (MAX).
3. Launch the Calibration Executive procedure and complete the setup wizard.

## Test Limit Equations

Table 268. PXIe-5655 Test Limit Equations

Equation Type	Equation
Internal Frequency Reference	<p>Calculate the deviation:</p> $\Delta f = \left( \frac{f_{\text{measured}} - 7.2\text{GHz}}{7.2\text{GHz}} \right) \times 10^9$ <p>Compare the deviation calculated against the test limits:</p> <ul style="list-style-type: none"> <li>• As-left Calculation: Initial Accuracy + Temperature Stability</li> <li>• As-found Calculation: Initial Accuracy + Aging + Temperature Stability</li> <li>• where <ul style="list-style-type: none"> <li>◦ Initial Accuracy = <math>\pm 6 \times 10^{-8}</math> Hz/Hz</li> <li>◦ Temperature Stability (15 °C to 35 °C) = <math>\pm 3 \times 10^{-8}</math> Hz/Hz</li> <li>◦ Aging after 30 days of continuous operation = <math>\pm 1.6 \times 10^{-7}</math> Hz/Hz per year</li> </ul> </li> </ul>

## PXIe-5663/5663E Calibration Procedure

Calibrate the the PXIe-5663/5663E using Calibration Executive.

### Calibration Executive Procedure Features

Verify Only ✓	Adjust Only ✓	Verify & Adjust ✓	Manual Mode ✓	Optional Adjust ✗
---------------	---------------	-------------------	---------------	-------------------

### Approximate Test Time

Verify Only	Adjust Only	Verify & Adjust
30 minutes	150 minutes	210 minutes



**Note** The PXIe-5663 consists of a PXIe-5601 RF downconverter module, PXIe-5622 IF digitizer module, and PXI-5652 RF signal generator module (used as an LO source). The PXIe-5663E also consists of a PXIe-5601 and PXIe-5622, but uses a PXIe-5652 RF signal generator module instead. There are no physical devices named PXIe-5663 and PXIe-5663E.

### Test Equipment

The following table lists the test instruments required for calibrating the PXIe-5663/5663E.

**Table 312.** Test equipment for calibrating the PXIe-5663/5663E

Instrument	Recommended Model	Specification	Value	Verification Parameter Measured	Run Modes
Spectrum Analyzer	Rohde & Schwarz FSU26 Spectrum Analyzer with required options FSU-B23 (20 dB preamplifier) and FSU-B25 (electronic attenuator)	Frequency range	500 kHz to 6.6 GHz	—	Verify & Adjust, Adjust Only
		Power level	–60 dBm to 20 dBm		
		Resolution bandwidth	10 Hz to		

Instrument	Recommended Model	Specification	Value	Verification Parameter Measured	Run Modes
			1 MHz		
		Phase noise (1 GHz, typical)	100 Hz	-100 dBc/Hz	
			1 kHz	-120 dBc/Hz	
			10 kHz	-130 dBc/Hz	
			100 kHz	-130 dBc/Hz	
			1 MHz	-142 dBc/Hz	
Power Meter	Anritsu ML2438A	Display resolution	<0.01 dB	Absolute accuracy, LO output power, Sideband spurs, Phase noise	Verify Only, Verify & Adjust, Adjust Only
		Settling	<0.1%		
		Instrument accuracy	<0.5%		
		Noise	<0.5% full-scale (lowest range)		
		Zero set and drift	<0.5% full-scale (lowest range)		
		Reference power uncertainty	<0.9%		
		Reference output VSWR	<1.04:1		
Diode Power Sensor (Connected to Port A of the Anritsu Power Meter)	Anritsu Ma2472 diode sensor	Range	-55 dBm to +20 dBm	Absolute accuracy,	Verify Only,
		Frequency range	10 MHz to 6.6 GHz	LO output power,	Verify &

Instrument	Recommended Model	Specification	Value	Verification Parameter Measured	Run Modes	
		Input VSWR	10 MHz to 50 MHz	<1.9:1	Sideband spurs, Phase noise	Adjust, Adjust Only
			50 MHz to 150 MHz	<1.17:1		
			150 MHz to 2 GHz	<1.12:1		
			2 GHz to 12.4 GHz	<1.22:1		
		Linearity		-55 dBm to 20 dBm <1.8%		
		Rise time		<4 $\mu$ s		
		Calibration Factor Uncertainty	50 MHz	<1.48%		
			100 MHz	<1.37%		
			300 MHz	<1.42%		
			500 MHz	<0.96%		
			1 GHz	<0.99%		
			2 GHz	<1.04%		
			3 GHz	<1.05%		
			4 GHz	<1.64%		
			5 GHz	<1.39%		
		6 GHz	<1.45%			
		7 GHz	<1.26%			
Diode Power Sensor (Connected to Port B of	Sc7400 diode sensor	Range		-55 dBm to +20 dBm	LO output power	Verify Only,
		Frequency range		10 MHz to		

Instrument	Recommended Model	Specification	Value	Verification Parameter Measured	Run Modes		
the Anritsu Power Meter)			6.6 GHz		Verify & Adjust, Adjust Only		
		Input VSWR	10 MHz to 50 MHz	<1.9:1			
			50 MHz to 150 MHz	<1.17:1			
			150 MHz to 2 GHz	<1.12:1			
			2 GHz to 12.4 GHz	<1.22:1			
		Linearity		-55 dBm to 20 dBm		<1.8%	
		Rise time				<4 μs	
		Calibration Factor Uncertainty	50 MHz	<1.48%			
			100 MHz	<1.37%			
			300 MHz	<1.42%			
			500 MHz	<0.96%			
			1 GHz	<0.99%			
			2 GHz	<1.04%			
			3 GHz	<1.05%			
4 GHz	<1.64%						
5 GHz	<1.39%						
6 GHz	<1.45%						
7 GHz	<1.26%						
USB Power Meter/Sensor	Rohde & Schwarz NRP-Z91 with NRP-Z4 USB adapter	Frequency range	900 kHz to 820 MHz	—	Verify & Adjust,		

Instrument	Recommended Model	Specification	Value	Verification Parameter Measured	Run Modes	
		Power measurement range	-4 dBm to 3 dBm		Adjust Only	
		Maximum VSWR	1.11 (23 ±5 °C)			
		Absolute power measurement uncertainty	0.1 dB (23 ±5 °C)			
		Relative power measurement uncertainty	0.05 dB (23 ±5 °C)			
Signal Generator (RF Source)	Anritsu MG3692B	Frequency range	10 MHz to 6.6 GHz	Absolute accuracy, LO output power, Sideband spurs	Verify Only, Verify & Adjust, Adjust Only	
		Power level	-60 dBm to 20 dBm			
Signal Generator (PN Source)	Rohde & Schwarz SMA100A base unit with required frequency option SMA-B103	Frequency range	1 GHz	Phase noise	Verify Only, Verify & Adjust, Adjust Only	
		Power level	0 dBm			
		Phase noise (1 GHz)	100 Hz			-107 dBc/Hz
			1 kHz			-125 dBc/Hz
			10 kHz			-137 dBc/Hz
			100 kHz			-137 dBc/Hz
1 MHz	-150 dBc/Hz					

Instrument	Recommended Model	Specification	Value	Verification Parameter Measured	Run Modes
Frequency Reference	Datum 8040 Rubidium Frequency Standard	Frequency	10 MHz	—	—
		Frequency Accuracy	1 ppb (typically $\pm 5E-11$ )		
Chassis	PXIe-1065, PXIe-1075	—	—	—	—
Chassis Controller	NI MXI-Express Kit	—	—	—	—
Connection Accessory	PXIe-5663/5663E Cable Accessory Kit	—	—	—	—
(2) 50 $\Omega$ Terminators	NI SMA 50 $\Omega$ Termination Plug	—	—	—	—
SMA (m) to SMA (f) Right Angle Adapter	Huber+Suhner 53_SMA-50-0-2/111_N	—	—	—	—
3.5 mm (m) to 3.5 mm (m) Adapter	Huber+Suhner 32_Pc35-50-0-2/199_NE	—	—	—	—
3.5 mm (f) Power Splitter (2 Resistor Type)	Aeroflex 1593	—	—	—	—
36 in SMA (m) to SMA (m) Cable	Huber+Suhner ST-18/SMAm/36	—	—	—	—
3.5 mm (m) to 3.5 mm (f) 30 dB Attenuator	Huber+Suhner 6630_SMA-50-1/199_NE	—	—	—	—
SMA Torque Wrench	Agilent 8710-1582	—	5 in/lb	—	—
3.5 mm	Agilent 8710-1765	—	8 in/lb	—	—



Instrument	Recommended Model	Specification	Value	Verification Parameter Measured	Run Modes
Torque Wrench					



**Note** NI strongly recommends using the instruments specified above when calibrating the PXIe-5663/5663E module. Substitution of instruments is permitted by Calibration Executive software, but NI cannot guarantee that unsupported instruments meet the specifications required for calibration.

## Test Conditions

The following setup and environmental conditions are required to ensure the PXIe-5663/5663E meets published specifications.

- Maintain an ambient temperature of  $23\text{ °C} \pm 5\text{ °C}$ .
- Keep the relative humidity between 10% and 90%, noncondensing.
- Ensure that the PXI Express chassis fan speed is set to HIGH, that the fan filters are clean, and that the empty slots contain filler panels. For more information, refer to the ***Maintain Forced-Air Cooling Note to Users*** document available at [ni.com/docs](http://ni.com/docs).
- Allow a warm-up time of at least 30 minutes after NI-RFSA is loaded and recognizes the PXIe-5663/5663E. The warm-up time ensures that the measurement circuitry of the PXIe-5663/5663E is at a stable operating temperature.
- Use an SMA torque wrench (5 in/lb, Agilent 8710-1582 or equivalent) to tighten any connection with an SMA connector.
- Use a 3.5 mm torque wrench (8 in/lb, Agilent 8710-1765 or equivalent) to tighten 3.5 mm or 2.92 mm (K) connections without an SMA connector.
- Lock all test equipment to the same reference frequency. Refer to the NI 5663/5663E Timing Configurations topic in the NI RF Vector Signal Analyzers Getting Started Guide.

## Device Setup

1. Install the PXIe-5663/5663E in the PXI Express chassis according to the instructions

in the NI RF Signal Generators Getting Started Guide.

2. Configure the hardware using Measurement & Automation Explorer (MAX). You must create a MAX association between the NI 5601 RF downconverter module and both the NI 5622 IF digitizer module and the NI 5652 LO source module to control the hardware modules as a single RF vector signal analyzer. Complete the following steps to make this association.
  - a. Right-click **PXIe-5601** and select **Properties**.
  - b. In the NI 5601 Device Properties dialog box, use the Digitizer drop-down listbox to specify the NI 5622 IF digitizer and the LO drop-down listbox to specify the NI 5652 LO source modules that are connected to the NI 5601 by front panel coaxial cables. Refer to the Interconnecting the NI 5663/5663E Modules section of the NI RF Vector Signal Analyzers Getting Started Guide for more information about connecting the modules.
  - c. Click **OK** to exit the dialog box.
3. Launch the Calibration Executive procedure. Calibration Executive guides you through the required connections.



**Tip** If you rename the NI 5622 and NI 5652 modules after association, you must repeat the association. Association between PXIe-5663/5663E hardware modules is lost when the previously associated IF digitizer and LO source modules are renamed.



**Note** During the calibration procedure, the 565x ALC Limits Table is validated to ensure the device is operating properly. Refer to ***Understanding Validate ALC Limits Table Results*** for information about ALC Limits Table validation.

#### Related concepts:

- [Launching a Calibration Procedure](#)
- [NI 5650/5651/5652 Calibration Procedure](#)

## PXIe-5665 (3.6 GHz) Calibration Procedure

Calibrate the PXIe-5665 3.6 GHz using Calibration Executive.

## Calibration Executive Procedure Features

Verify Only ✓	Verify & Adjust ✓	Manual Mode ✗	Optional Adjust ✗
---------------	-------------------	---------------	-------------------

### Approximate Test Time

Verify Only	Verify & Adjust
50 minutes	135 minutes



**Note** The PXIe-5665 3.6 GHz is comprised of the PXIe-5603 RF downconverter module, the PXIe-5622 IF digitizer module, and the PXI-5653 synthesizer/LO source. There is no physical device named PXIe-5665.

### Test Equipment

The following table lists the test instruments required for calibrating the PXIe-5665.

**Table 270.** Test equipment for calibrating the PXIe-5665 3.6 GHz

Instrument	Recommended Model	Specification	Value
Power Meter	Anritsu ML2438A	Display Resolution	<0.01 dB
		Settling	±0.1%
		Instrument Accuracy	<±0.5%
		Noise, Zero Set, and Drift	<±0.5% full-scale (lowest range)
		Reference Power Uncertainty	<±0.9%
		Reference Output VSWR	<1.04:1
Power Sensor A	Anritsu MA2473D	Power Range	-60 dBm to 20 dBm
		Frequency Range	10 MHz to 18 GHz
		Input VSWR	10 MHz to <1.90:1

Instrument	Recommended Model	Specification		Value		
			50 MHz			
			50 MHz to 2 GHz	<1.12:1		
			2 GHz to 12.4 GHz	<1.22:1		
			12.4 GHz to 18 GHz	<1.25:1		
		Linearity			-60 dBm to 20 dBm <1.8%	
		Calibration Factor Uncertainty	50 MHz	<1.48%		
			10 MHz to 50 MHz	<1.9%		
			50 MHz to 500 MHz	<1.5%		
			500 MHz to 7 GHz	<1.5%		
			7 GHz to 12.4 GHz	<1.9%		
			12.4 GHz to 18 GHz	<2.3%		
		Power Sensor B	Anritsu Ma2421	Power Range		-50 dBm to 20 dBm
				Frequency Range		100 kHz to 18 GHz
Input VSWR	10 MHz to 50 MHz			<1.90:1		
	50 MHz to 2 GHz			<1.12:1		
	2 GHz to 12.4 GHz			<1.22:1		
	12.4 GHz to			<1.25:1		

Instrument	Recommended Model	Specification		Value
			18 GHz	
		Linearity		-60 dBm to 20 dBm <1.8%
		Calibration Factor Uncertainty	50 MHz	<1.48%
			10 MHz to 50 MHz	<1.9%
			50 MHz to 500 MHz	<1.5%
			500 MHz to 7 GHz	<1.5%
			7 GHz to 12.4 GHz	<1.9%
			12.4 GHz to 18 GHz	<2.3%
Signal Generator (RF Source 1)	Anritsu MG3692C Options 2A, 3, 4, 15A, and 22	Frequency Range		8 MHz to 20 GHz
		Leveled Power		-115 dBm to 18 dBm
		Power Accuracy		$\pm 1.5$ dB
		Harmonics (typical)	0.1 MHz to $\leq 10$ MHz	<-30 dBc
			>10 MHz to $\leq 100$ MHz	<-40 dBc
			>100 MHz to $\leq 2.2$ GHz	<-50 dBc
			>2.2 GHz to $\leq 20$ GHz	<-30 dBc
		Nonharmonic Spurious	0.1 MHz to $\leq 10$ MHz	<-30 dBc
			>10 MHz to $\leq 2.2$ GHz	<-60 dBc

Instrument	Recommended Model	Specification		Value
			>2.2 GHz to ≤20 GHz	<-60 dBc
		Output VSWR		<2.0:1 (typical)
Signal Generator (RF Source 2)	Anritsu MG3692C Options 2A, 3, 4, 15A, and 22	Frequency Range		0.1 Hz to 20 GHz
		Leveled Power		-115 dBm to 18 dBm
		Power Accuracy		±1.5 dB
		Harmonics (typical)	0.1 MHz to ≤10 MHz	<-30 dBc
			>10 MHz to ≤100 MHz	<-40 dBc
			>100 MHz to ≤2.2 GHz	<-50 dBc
			>2.2 GHz to ≤20 GHz	<-30 dBc
		Nonharmonic Spurious	0.1 MHz to ≤10 MHz	<-30 dBc
			>10 MHz to ≤2.2 GHz	<-60 dBc
			>2.2 GHz to ≤20 GHz	<-60 dBc
Output VSWR		<2.0:1 (typical)		
Spectrum Analyzer	Rohde & Schwarz FSUP26 Options B60 and B61	Frequency Range		10 MHz to 24 GHz
		Noise Floor		<-152 dBm/Hz
		Phase noise measurement using cross-correlation		—
		Frequency counter marker		—

Instrument	Recommended Model	Specification	Value	
		feature		
		Spectrum analysis capabilities	—	
50 $\Omega$ Terminators (three are included in the PXIe-5665 kit)	NI SMA 50 $\Omega$ Termination Plug	—	—	
PXI Express Chassis	PXIe-1065, PXIe-1075	—	—	
PXI Express Controller	PXIe-8105, PXIe-8133	—	—	
Connection Accessory	PXIe-5665 Cable Accessory Kit	—	—	
36 in SMA (m) to SMA (m) Cable (x3)	MegaPhase G916-SISI-36	Frequency Range	DC to 18 GHz	
		Insertion Loss	$\leq 2$ dB at 18 GHz	
		Impedance	50 $\Omega$	
		VSWR	$\leq 1.35:1$ at 18 GHz	
3.5 mm (m) to 3.5 mm (m) Adapter	Huber+Suhner 32_Pc35-50-0-2/199_NE	Frequency Range	DC to 33 GHz	
		Impedance	50 $\Omega$	
		Return Loss	DC to 1.5 GHz	$\geq 35$ dB
			1.5 GHz to 6.0 GHz	$\geq 30$ dB
6.0 GHz to 18.0 GHz	$\geq 20$ dB			
3.5 mm (f) to 3.5 mm (f) Adapter	Huber+Suhner 31_Pc35-50-0-2/199_N	Frequency Range	DC to 18 GHz	
		Impedance	50 $\Omega$	
		Return Loss	DC to 1.5 GHz	$\geq 35$ dB
			1.5 GHz to 6.0 GHz	$\geq 30$ dB
6.0 GHz to	$\geq 20$ dB			

Instrument	Recommended Model	Specification	Value
		18.0 GHz	
SMA (m) to SMA (f) 10 dB Attenuator	Huber+Suhner 6610_SMA-50-1/199N	Frequency Range	DC to 18 GHz
		Attenuation	10 dB (nominal)
		Power Rating	2 W average
		Impedance	50 Ω
		VSWR	DC to 4 GHz
4 GHz to 8 GHz	≤1.20:1		
8 GHz to 12.4 GHz	≤1.25:1		
12.4 GHz to 18 GHz	≤1.35:1		
SMA (m) to SMA (f) 20 dB Attenuator	Huber+Suhner 6620_SMA-50-1/199N	Frequency Range	DC to 18 GHz
		Attenuation	20 dB (nominal)
		Power Rating	2 W average
		Impedance	50 Ω
		VSWR	DC to 4 GHz
4 GHz to 8 GHz	≤1.20:1		
8 GHz to 12.4 GHz	≤1.25:1		
12.4 GHz to 18 GHz	≤1.35:1		
Power Splitter (Two-Resistor Type)	Aeroflex/Weinschel 1593	Frequency Range	DC to 26.5 GHz
		Amplitude Tracking	<0.25 dB
		Phase Tracking	<4°
		Insertion Loss	≤8.5 dB (6 dB,



Instrument	Recommended Model	Specification	Value	
			nominal)	
		Power Rating	1 W	
		Impedance	50 $\Omega$	
		VSWR	DC to 26.5 GHz	$\leq 1.25:1$
		Equivalent Output VSWR	DC to 18 GHz	$\leq 1.25:1$
			18 GHz to 26.5 GHz	$\leq 1.35:1$
Connectors	3.5 mm (f)			
Anti-Distortion Fixture	NI-5665 Anti-Distortion Fixture (PN: 166375)	—	—	
Frequency Reference Source	Datum 8040 Rubidium Frequency Standard	Frequency	10 MHz	
		Frequency Accuracy	$\pm 1 \times 10^{-9}$	
Torque Wrench	—	Refer to the <b>Test Conditions</b> section for torque wrench specifications	—	



**Note** If using a Rohde & Schwarz FSUP as one of the standards, select it as both **Spectrum Analyzer** and **Signal Source Analyzer**. If not, select **Unsupported Instrument** for the **Signal Source Analyzer**.

## Test Conditions

The following setup and environmental conditions are required to ensure the PXIe-5665 meets published specifications.

- Maintain an ambient temperature of  $23\text{ }^{\circ}\text{C} \pm 5\text{ }^{\circ}\text{C}$ .
- Keep the relative humidity between 10% and 90%, noncondensing.
- Ensure that the PXI Express chassis fan speed is set to HIGH, that the fan filters are

clean, and that the empty slots contain filler panels. For more information, refer to the ***Maintain Forced-Air Cooling Note to Users*** document available at [ni.com/docs](http://ni.com/docs).

- Allow a warm-up time of at least 30 minutes after NI-RFSA is loaded and recognizes the PXIe-5665. The warm-up time ensures that the measurement circuitry of the PXIe-5665 is at a stable operating temperature.
- Use a torque wrench appropriate for the type of RF connector that you are using. NI recommends a 0.565 N · m (5 lb · in.) wrench for SMA connectors and an 0.90 N · m (8 lb · in.) wrench for 3.5 mm connectors.
- Connect the frequency reference source to the REF IN connector on the back of the PXI Express chassis with a standard BNC (m)-to BNC (m) cable. This connection replaces the connection from the NI 5653 REF OUT (10 MHz) connector to the PXI Express chassis REF IN connector, if present.
- Lock all test equipment to the same reference frequency. Refer to the NI 5665 Timing Configuration topic in the NI RF Vector Signal Analyzers Getting Started Guide.
- Self-calibration for the PXIe-5665 should be performed before running the verification test procedures.

## Device Setup

1. Install the PXIe-5665 in the PXI Express chassis according to the instructions in the NI RF Signal Generators Getting Started Guide.
2. Configure the hardware using Measurement & Automation Explorer (MAX). You must create a MAX association between the NI 5603 RF downconverter module and both the NI 5622 IF digitizer module and the NI 5653 LO source module to control the hardware modules as a single RF vector signal analyzer. Complete the following steps to make this association.
  - a. Right-click **NI PXIe-5603** and select **Properties**.
  - b. In the NI 5603 Device Properties dialog box, use the Digitizer drop-down list to specify the NI 5622 IF digitizer and the LO drop-down list to specify the NI 5653 LO source modules that are connected to the NI 5603 by front panel coaxial cables. Refer to the Interconnecting the NI 5665 Modules section of the NI RF Vector Signal Analyzers Getting Started Guide for more information about connecting the modules.



**Tip** If you rename the NI 5622 and NI 5653 modules after association,

you must repeat the association. Association between PXIe-5665 hardware modules is lost when the previously associated IF digitizer and LO source modules are renamed.

- c. Click **OK** to exit the dialog box.
- 3. Launch the Calibration Executive procedure. Calibration Executive guides you through the required connections.

## Test Limit Equations

Table 271. PXIe-5665 (3.6 GHz) Test Limit Equations

Equation Type	Equation
Verify Reference Frequency Accuracy	$\text{TestLimits} = \text{TestValue} \pm (\text{InitialAccuracy} + \text{Aging} + \text{TemperatureStability})$ <ul style="list-style-type: none"> <li>• InitialAccuracy = 50 ppb</li> <li>• Aging = 100 ppb/year</li> <li>• TemperatureStability = 10 ppb</li> </ul>

## PXIe-5665 (14 GHz) Calibration Procedure

Calibrate the PXIe-5665 14 GHz using Calibration Executive.

### Calibration Executive Procedure Features

Verify Only ✓	Verify & Adjust ✓	Manual Mode ✗	Optional Adjust ✗
---------------	-------------------	---------------	-------------------

### Approximate Test Time

Verify Only	Verify & Adjust
90 minutes	160 minutes



**Note** The PXIe-5665 14 GHz is comprised of the PXIe-5605 RF downconverter module, the PXIe-5622 IF digitizer module, and the PXI-5653 synthesizer/LO

source. There is no physical device named PXIe-5665.

## Test Equipment

The following table lists the test instruments required for calibrating the PXIe-5665.

**Table 272.** Test equipment for calibrating the PXIe-5665 14 GHz

Instrument	Recommended Model	Specification	Value	
Power Meter	Anritsu ML2438A	Display Resolution	<0.01 dB	
		Settling	±0.1%	
		Instrument Accuracy	<±0.5%	
		Noise, Zero Set, and Drift	<±0.5% full-scale (lowest range)	
		Reference Power Uncertainty	<±0.9%	
		Reference Output VSWR	<1.04:1	
Power Sensor A	Anritsu MA2473D	Power Range	–60 dBm to 20 dBm	
		Frequency Range	10 MHz to 18 GHz	
		Input VSWR	10 MHz to 50 MHz	<1.90:1
			50 MHz to 2 GHz	<1.12:1
			2 GHz to 12.4 GHz	<1.22:1
			12.4 GHz to 18 GHz	<1.25:1
		Linearity	–60 dBm to 20 dBm	<1.8%
		Calibration Factor Uncertainty	50 MHz	<1.48%
			10 MHz to	<1.9%

Instrument	Recommended Model	Specification		Value
			50 MHz	
			50 MHz to 500 MHz	<1.5%
			500 MHz to 7 GHz	<1.5%
			7 GHz to 12.4 GHz	<1.9%
			12.4 GHz to 18 GHz	<2.3%
Power Sensor B	Anritsu Ma2421	Power Range		-50 dBm to 20 dBm
		Frequency Range		100 kHz to 18 GHz
		Input VSWR	10 MHz to 50 MHz	<1.90:1
			50 MHz to 2 GHz	<1.12:1
			2 GHz to 12.4 GHz	<1.22:1
			12.4 GHz to 18 GHz	<1.25:1
		Linearity		-60 dBm to 20 dBm<1.8%
		Calibration Factor Uncertainty	50 MHz	<1.48%
			10 MHz to 50 MHz	<1.9%
			50 MHz to 500 MHz	<1.5%
			500 MHz to 7 GHz	<1.5%
			7 GHz to 12.4 GHz	<1.9%

Instrument	Recommended Model	Specification		Value
			12.4 GHz to 18 GHz	<2.3%
Signal Generator (RF Source 1)	Anritsu MG3692C Options 2A, 3, 4, 15A, and 22	Frequency Range		8 MHz to 20 GHz
		Leveled Power		-115 dBm to 18 dBm
		Power Accuracy		$\pm 1.5$ dB
		Harmonics (typical)	0.1 MHz to $\leq 10$ MHz	<-30 dBc
			>10 MHz to $\leq 100$ MHz	<-40 dBc
			>100 MHz to $\leq 2.2$ GHz	<-50 dBc
			>2.2 GHz to $\leq 20$ GHz	<-30 dBc
		Nonharmonic Spurious	0.1 MHz to $\leq 10$ MHz	<-30 dBc
			>10 MHz to $\leq 2.2$ GHz	<-60 dBc
			>2.2 GHz to $\leq 20$ GHz	<-60 dBc
Output VSWR		<2.0:1 (typical)		
Signal Generator (RF Source 2)	Anritsu MG3692C Options 2A, 3, 4, 15A, and 22	Frequency Range		0.1 Hz to 20 GHz
		Leveled Power		-115 dBm to 18 dBm
		Power Accuracy		$\pm 1.5$ dB
		Harmonics	0.1 MHz to	<-30 dBc

Instrument	Recommended Model	Specification	Value	
		(typical)	≤10 MHz	
			>10 MHz to ≤100 MHz	<-40 dBc
			>100 MHz to ≤2.2 GHz	<-50 dBc
			>2.2 GHz to ≤20 GHz	<-30 dBc
		Nonharmonic Spurious	0.1 MHz to ≤10 MHz	<-30 dBc
			>10 MHz to ≤2.2 GHz	<-60 dBc
			>2.2 GHz to ≤20 GHz	<-60 dBc
		Output VSWR		
Spectrum Analyzer	Rohde & Schwarz FSUP26 Options B60 and B61	Frequency Range	10 MHz to 24 GHz	
		Noise Floor	<-152 dBm/Hz	
		Phase noise measurement using cross-correlation	—	
		Frequency counter marker feature	—	
		Spectrum analysis capabilities	—	
50 Ω Terminators (three are included in the PXIe-5665 kit)	NI SMA 50 Ω Termination Plug	—	—	
PXI Express Chassis	PXIe-1065, PXIe-1075	—	—	
PXI Express Controller	PXIe-8105, PXIe-8133	—	—	

Instrument	Recommended Model	Specification	Value	
Connection Accessory	PXIe-5665 Cable Accessory Kit	—	—	
36 in SMA (m) to SMA (m) Cable (x3)	MegaPhase G916-SISI-36	Frequency Range	DC to 18 GHz	
		Insertion Loss	≤2 dB at 18 GHz	
		Impedance	50 Ω	
		VSWR	≤1.35:1 at 18 GHz	
3.5 mm (m) to 3.5 mm (m) Adapter	Huber+Suhner 32_Pc35-50-0-2/199_NE	Frequency Range	DC to 33 GHz	
		Impedance	50 Ω	
		Return Loss	DC to 1.5 GHz	≥35 dB
			1.5 GHz to 6.0 GHz	≥30 dB
6.0 GHz to 18.0 GHz	≥20 dB			
3.5 mm (f) to 3.5 mm (f) Adapter	Huber+Suhner 31_Pc35-50-0-2/199_N	Frequency Range	DC to 18 GHz	
		Impedance	50 Ω	
		Return Loss	DC to 1.5 GHz	≥35 dB
			1.5 GHz to 6.0 GHz	≥30 dB
6.0 GHz to 18.0 GHz	≥20 dB			
SMA (m) to SMA (f) 10 dB Attenuator	Huber+Suhner 6610_SMA-50-1/199N	Frequency Range	DC to 18 GHz	
		Attenuation	10 dB (nominal)	
		Power Rating	2 W average	
		Impedance	50 Ω	
		VSWR	DC to 4 GHz	≤1.15:1
			4 GHz to	≤1.20:1



Instrument	Recommended Model	Specification	Value	
		8 GHz		
		8 GHz to 12.4 GHz	≤1.25:1	
		12.4 GHz to 18 GHz	≤1.35:1	
SMA (m) to SMA (f) 20 dB Attenuator	Huber+Suhner 6620_SMA-50-1/199N	Frequency Range	DC to 18 GHz	
		Attenuation	20 dB (nominal)	
		Power Rating	2 W average	
		Impedance	50 Ω	
		VSWR	DC to 4 GHz	≤1.15:1
			4 GHz to 8 GHz	≤1.20:1
			8 GHz to 12.4 GHz	≤1.25:1
			12.4 GHz to 18 GHz	≤1.35:1
Power Splitter (Two-Resistor Type)	Aeroflex/Weinschel 1593	Frequency Range	DC to 26.5 GHz	
		Amplitude Tracking	<0.25 dB	
		Phase Tracking	<4°	
		Insertion Loss	≤8.5 dB (6 dB, nominal)	
		Power Rating	1 W	
		Impedance	50 Ω	
		VSWR	DC to 26.5 GHz	≤1.25:1
		Equivalent Output VSWR	DC to 18 GHz	≤1.25:1
18 GHz to 26.5 GHz	≤1.35:1			

Instrument	Recommended Model	Specification	Value
		Connectors	3.5 mm (f)
Anti-Distortion Fixture	NI-5665 Anti-Distortion Fixture (PN: 166375)	—	—
Frequency Reference Source	Datum 8040 Rubidium Frequency Standard	Frequency	10 MHz
		Frequency Accuracy	$\pm 1 \times 10^{-9}$
Torque Wrench	—	Refer to the section for torque wrench specifications	—



**Note** If using a Rohde & Schwarz FSUP as one of the standards, select it as both **Spectrum Analyzer** and **Signal Source Analyzer**. If not, select **Unsupported Instrument** for the **Signal Source Analyzer**.

## Test Conditions

The following setup and environmental conditions are required to ensure the PXIe-5665 meets published specifications.

- Maintain an ambient temperature of  $23\text{ }^{\circ}\text{C} \pm 5\text{ }^{\circ}\text{C}$ .
- Keep the relative humidity between 10% and 90%, noncondensing.
- Ensure that the PXI Express chassis fan speed is set to HIGH, that the fan filters are clean, and that the empty slots contain filler panels. For more information, refer to the ***Maintain Forced-Air Cooling Note to Users*** document available at [ni.com/docs](http://ni.com/docs).
- Allow a warm-up time of at least 30 minutes after NI-RFSA is loaded and recognizes the PXIe-5665. The warm-up time ensures that the measurement circuitry of the PXIe-5665 is at a stable operating temperature.
- Use a torque wrench appropriate for the type of RF connector that you are using. NI recommends a  $0.565\text{ N}\cdot\text{m}$  ( $5\text{ lb}\cdot\text{in.}$ ) wrench for SMA connectors and an  $0.90\text{ N}\cdot\text{m}$  ( $8\text{ lb}\cdot\text{in.}$ ) wrench for 3.5 mm connectors.
- Connect the frequency reference source to the REF IN connector on the back of the PXI Express chassis with a standard BNC (m)-to BNC (m) cable. This connection replaces the connection from the NI 5653 REF OUT (10 MHz) connector to the PXI

Express chassis REF IN connector, if present.

- Lock all test equipment to the same reference frequency. Refer to the NI 5665 Timing Configuration topic in the NI RF Vector Signal Analyzers Getting Started Guide.
- Self-calibration for the PXIe-5665 should be performed before running the verification test procedures.

## Device Setup

1. Install the PXIe-5665 in the PXI Express chassis according to the instructions in the NI RF Signal Generators Getting Started Guide.
2. Configure the hardware using Measurement & Automation Explorer (MAX). You must create a MAX association between the NI 5605 RF downconverter module and both the NI 5622 IF digitizer module and the NI 5653 LO source module to control the hardware modules as a single RF vector signal analyzer. Complete the following steps to make this association.
  - a. Right-click **NI PXIe-5605** and select **Properties**.
  - b. In the NI 5605 Device Properties dialog box, use the Digitizer drop-down list to specify the NI 5622 IF digitizer and the LO drop-down list to specify the NI 5653 LO source modules that are connected to the NI 5605 by front panel coaxial cables. Refer to the Interconnecting the NI 5665 Modules section of the NI RF Vector Signal Analyzers Getting Started Guide for more information about connecting the modules.



**Tip** If you rename the NI 5622 and NI 5653 modules after association, you must repeat the association. Association between PXIe-5665 hardware modules is lost when the previously associated IF digitizer and LO source modules are renamed.

- c. Click **OK** to exit the dialog box.
3. Launch the Calibration Executive procedure. Calibration Executive guides you through the required connections.

## Test Limit Equations

Table 273. PXIe-5665 (14 GHz) Test Limit Equations

Equation Type	Equation
Reference Frequency Accuracy	$\text{TestLimits} = \text{TestValue} \pm (\text{InitialAccuracy} + \text{Aging} + \text{TemperatureStability})$ <ul style="list-style-type: none"> <li>InitialAccuracy = 50 ppb</li> <li>Aging = 100 ppb/year</li> <li>TemperatureStability = 10 ppb</li> </ul>

## PXIe-5668R Calibration Procedure

Calibrate the PXIe-5668R vector signal analyzer (VSA) using Calibration Executive. In this procedure, **NI 5668R** refers to both the PXIe-5668R 26.5 GHz VSA and the PXIe-5668R 14 GHz VSA unless otherwise specified. The PXIe-5668R is composed of the PXIe-5606 RF Downconverter, the PXIe-5624 IF Digitizer and the PXIe-5653 RF Synthesizer.

## Calibration Executive Procedure Features

Verify Only ✓	Adjust Only ✓	Verify & Adjust ✗	Manual Mode ✗	Optional Adjust ✗
---------------	---------------	-------------------	---------------	-------------------

## Approximate Test Time

Verify Only	Adjust Only
85 minutes	180 minutes

## Test Equipment

- Verification Only Test Equipment
- Adjust Only Test Equipment

## Test Conditions

The following setup and environmental conditions are required to ensure the NI 5668R meets published specifications.

- Keep cabling as short as possible. Long cables and wires act as antennas, picking up extra noise that can affect measurements.
- Verify that all connections, including front panel connections and screws, are secure.
- Maintain an ambient temperature of  $23\text{ }^{\circ}\text{C} \pm 5\text{ }^{\circ}\text{C}$ .
- Keep the relative humidity between 10% and 90%, noncondensing.
- Ensure that the PXI/PXI Express chassis fan speed is set to HIGH and that the empty slots contain filler panels. For more information about maintaining adequate air circulation in your PXI/PXI Express chassis, refer to the Maintain Forced-Air Cooling Note to Users document available at [ni.com/manuals](http://ni.com/manuals).
- Allow a warm-up time of at least 30 minutes after NI-RFSA is loaded and recognizes the NI 5668R. The warm-up time ensures that the measurement circuitry of the NI 5668R is at a stable operating temperature.
- Use a torque wrench appropriate for the type of RF connector that you are using. NI recommends a  $0.565\text{ N}\cdot\text{m}$  ( $5\text{ lb}\cdot\text{in.}$ ) wrench for SMA connectors and an  $0.90\text{ N}\cdot\text{m}$  ( $8\text{ lb}\cdot\text{in.}$ ) wrench for 2.9 mm connectors.
- Connect the frequency reference source to the REF IN connector on the PXI Express chassis with a standard BNC (m)-to-BNC (m) cable. This connection replaces the connection from the NI 5653 REF OUT (10 MHz) connector to the PXI Express chassis REF IN connector, if present.
- Lock all test equipment to the REF OUT signal on the back of the PXI Express chassis. Refer to the NI 5668R Timing Configurations topic in the NI RF Vector Signal Analyzers Help for more information about configuring clocking sources.

## Device Setup

Refer to the PXIe-5668 Getting Started Guide for information about how to install the software and hardware and how to configure the device in Measurement & Automation Explorer (MAX).



**Note** A warmup begins when the procedure initializes. Warmup may cause

indeterminate delay at the YTF Self Alignment step.

1. Install the NI 5668R in the PXI Express chassis according to the instructions in the NI RF Signal Generators Getting Started Guide.
2. Configure the hardware using Measurement & Automation Explorer (MAX). You must create a MAX association between the hardware modules to control them as a single RF device before you can program the device. Complete the following steps to make this association.
  - a. In MAX, select the NI 5606 RF downconverter in the configuration tree.
  - b. In the Associated Devices section, select the appropriate module from each system component drop-down listbox.

For NI 5668R, you must associate the NI 5624R IF digitizer module and the NI 5653 LO source module with the NI 5606 RF downconverter.



**Note** Device associations are lost when you move modules to different chassis slots.

- c. Click **Save** in the MAX toolbar.
3. Launch the Calibration Executive procedure. Calibration Executive guides you through the required connections.

#### Related concepts:

- [PXIe-5624 Calibration Procedure](#)
- [PXIe-5653 Calibration Procedure](#)
- [Launching a Calibration Procedure](#)

#### Related information:

- [Getting Started with the PXI-5661](#)

#### PXIe-5668R Test Equipment (Adjust Only)

The following table lists the test equipment required for calibrating the NI 5668R in Adjust Only mode.

Refer to **Test Equipment (Verification Only)** table for a list of test equipment required for calibrating the NI 5668R in Verification Only mode. Refer also to test equipment tables for PXIe-5606, PXIe-5624 and PXIe-5653.

## Test Equipment (Adjust Only)

**Table 275.** Test equipment for calibrating the PXIe-5668R in Adjust Only mode

Instrument	Recommended Model	Where Used	Requirements
Instrument	Recommended Model	Where Used	Requirements
Signal source analyzer	Rohde & Schwarz (R&S) FSUP Signal Source Analyzer	Adjust Reference accuracy  Adjust YIG frequency accuracy	Frequency range: 9 MHz to 10 GHz  Frequency accuracy: 1 ppb over the frequency range, 900 MHz to 9 GHz recommended  Noise floor: < -152 dBm/Hz  Phase noise measurement using cross-correlation  Frequency counter marker feature  Spectrum analysis capabilities
Power meter	Anritsu ML2438A	Adjust LO1, LO2, LO3 output power  IF Gain Adjustment  Lowband RF Response  Highband RF Response  LO Output Power  Test system characterization	Display resolution: $\leq 0.01$ dB  Settling: $\pm 0.1\%$  Instrumentation accuracy: $< \pm 0.5\%$  Noise, zero set, and drift: $< \pm 0.5\%$ full-scale (lowest range)  Reference power uncertainty: $< \pm 0.9\%$  Reference output VSWR: $< 1.04 : 1$

Instrument	Recommended Model	Where Used	Requirements
Power sensor (x2)	Anritsu SC7413	<p>Adjust LO1, LO2, LO3 output power</p> <p>IF Gain Adjustment</p> <p>Lowband RF Response</p> <p>Highband RF Response</p> <p>LO Output Power</p> <p>Test system characterization</p>	<p>Power range: -55 dBm to 20 dBm</p> <p>Frequency range: 100 kHz to 26.5 GHz</p> <p>Input VSWR:</p> <ul style="list-style-type: none"> <li>• &lt;150 MHz: &lt;1.17 : 1</li> <li>• 150 MHz to &lt;2 GHz: &lt;1.08 : 1</li> <li>• 2 GHz to &lt;12.4 GHz: &lt;1.16 : 1</li> <li>• 12.4 GHz to &lt;18 GHz: &lt;1.21 : 1</li> <li>• 18 GHz to &lt;32 GHz: &lt;1.29 : 1</li> </ul> <p>Linearity:</p> <ul style="list-style-type: none"> <li>• &lt;18 GHz: &lt;1.8%</li> <li>• &lt;27 GHz: &lt;2.5%</li> </ul> <p>Refer to the <b>NI PXIe-5668R Calibration Procedure</b> for calibration factor uncertainty (2 <math>\sigma</math>) specifications.</p>
Signal generator (RF source 1)*	Rohde & Schwarz SMA100A base unit with required frequency option SMA-B103	<p>Splitter balance characterization</p> <p>Adjusting internal frequency reference</p> <p>Adjusting absolute amplitude accuracy</p>	<p>Frequency range: 4 MHz to 2.005 GHz</p> <p>Amplitude range: -10 dBm to 10 dBm</p> <p>Frequency accuracy: <math>\leq \pm 3.5 \times 10^{-8}</math></p>
Signal generator (RF source 2)*	Anritsu MG3694C Options 1A, 2B, 4, 22, and 28B	<p>IF Gain Adjustment</p> <p>Low Band Calibration</p> <p>High Band Calibration</p>	<p>Frequency range: 16 kHz to 26.9 GHz</p> <p>Leveled power: -30 dBm to 10</p>



Instrument	Recommended Model	Where Used	Requirements
	Note: Do not use option 15	Test system characterization	<p>dBm</p> <p>Power accuracy: <math>\pm 1.5</math> dB</p> <p>Harmonics:</p> <ul style="list-style-type: none"> <li>• 16 kHz to <math>\leq 10</math> MHz: <math>&lt; -30</math> dBc</li> <li>• <math>&gt; 10</math> MHz to <math>\leq 100</math> MHz: <math>&lt; -40</math> dBc</li> <li>• <math>&gt; 100</math> MHz to <math>\leq 2.2</math> GHz: <math>&lt; -50</math> dBc</li> <li>• <math>&gt; 2.2</math> GHz to <math>\leq 20</math> GHz: <math>&lt; -60</math> dBc</li> <li>• <math>&gt; 20</math> GHz to <math>\leq 26.9</math> GHz: <math>&lt; -40</math> dBc</li> </ul> <p>Nonharmonic spurious:</p> <ul style="list-style-type: none"> <li>• 16 kHz to <math>\leq 10</math> MHz: <math>&lt; -30</math> dBc</li> <li>• <math>&gt; 10</math> MHz to <math>\leq 2.2</math> GHz: <math>&lt; -60</math> dBc</li> <li>• <math>&gt; 2.2</math> GHz to <math>\leq 26.9</math> GHz: <math>&lt; -60</math> dBc</li> </ul> <p>Output VSWR: <math>&lt; 2.0 : 1</math></p>
Frequency reference source	Symmetricon 8040C rubidium frequency standard	All test steps	Frequency: 10 MHz Frequency accuracy: $\leq 1 \times 10^{-9}$
Torque wrench	—	—	Refer to <b>Test Conditions</b> for torque wrench specifications.
PXI Express chassis	PXIe-1075 or PXIe-1085	All test steps	—
PXI Express controller	PXIe-8133 or PXIe-8135	All test steps	—
50 $\Omega$	NI 778353-01	IF Gain Adjustment	—

Instrument	Recommended Model	Where Used	Requirements
terminations (x4)†		Lowband RF Response Highband RF Response LO Output Power Splitter balance characterization Factory Self Calibration steps	
SMA-to-SMA cable, labeled U‡	NI 152637A-01	All test steps	—
SMA-to-SMA cable, labeled V‡	NI 152638A-01	All test steps	—
SMA-to-SMA cable, labeled W‡	NI 152639A-01	All test steps	—
SMA-to-SMA cable, labeled X‡	NI 152640A-01	All test steps	—
SMA-to-SMA cable, labeled Y‡	NI 152641A-01	All test steps	—
2.92 mm (m)-to-2.92 mm (m) cables (36 in.) (x2)	Florida RF Labs KMS-160-36.0-KMS	IF Gain Adjustment Lowband RF Response Highband RF Response Test system characterization Adjust Reference	Frequency Range: 16 kHz to 26.9 GHz Insertion Loss: ≤30 dB/100 ft at 5 GHz Impedance: 50 Ω

Instrument	Recommended Model	Where Used	Requirements
		accuracy  Adjust YIG frequency accuracy	
2.92 mm (m)-to-2.92 mm (m) cables (12 in.) (x2)	Florida RF Labs KMS-160-12.0-KMS	LO Output Power	Frequency Range: 16 kHz to 26.9 GHz  Insertion Loss: $\leq 30$ dB/100 ft at 5 GHz  Impedance: 50 $\Omega$
2.92 mm (m)-to-2.92 mm (m) adaptor	Anritsu K220B	IF Gain Adjustment  Lowband RF Response  Highband RF Response  Test system characterization	Frequency range: 10 MHz to 26.9 GHz  Impedance: 50 $\Omega$  VSWR: $< 1.12 : 1$
2.92 mm (f)-to-2.92 mm (f) adaptor (x2)	Fairview Microwave SM4953	LO Output Power Test system characterization	Frequency range: 16 kHz to 26.9 GHz  Impedance: 50 $\Omega$  VSWR: $< 1.15 : 1$
Power splitter (two-resistor type)	Api Weinschel 1534	IF Gain Adjustment  Lowband RF Response  Highband RF Response  Test system characterization	Frequency range: 10 MHz to 26.9 GHz  Amplitude tracking: $< 0.50$ dB  Phase tracking: $< 4^\circ$  Insertion loss: $\leq 10.5$ dB  Power rating: 1 W

Instrument	Recommended Model	Where Used	Requirements
			<p>Impedance: 50 <math>\Omega</math></p> <p>VSWR:</p> <ul style="list-style-type: none"> <li>• 10 MHz to 18 GHz: <math>\leq 1.25 : 1</math></li> <li>• 18 to 26.5 GHz: <math>\leq 1.4 : 1</math></li> <li>• 26.5 to 26.9 GHz: <math>\leq 1.6 : 1</math></li> </ul> <p>Equivalent output VSWR:</p> <ul style="list-style-type: none"> <li>• 10 MHz to 26.5 GHz: <math>\leq 1.35 : 1</math></li> <li>• 26.5 GHz to 26.9 GHz: <math>\leq 1.6 : 1</math></li> </ul> <p>Connectors: 2.92 mm (f)</p>
Power splitter (two-resistor type)	Aeroflex/Weinschel 1593	Splitter balance characterization Adjusting absolute amplitude accuracy	<p>Frequency range: DC to 2 GHz</p> <p>Amplitude tracking: <math>&lt; 0.25</math> dB</p> <p>Maximum input power: <math>&lt; 10</math> dBm CW</p>
6 dB attenuator	Anritsu 41KB-6 or Mini-Circuits BW-S6W2	Splitter balance characterization Adjusting absolute amplitude accuracy	<p>Frequency range: DC to 2 GHz</p> <p>VSWR: <math>&lt; 1.2</math></p>
SMA (m)-to-SMA (m) cable (x2)	—	<p>Splitter balance characterization</p> <p>Adjusting internal frequency reference</p> <p>Adjusting absolute amplitude accuracy</p>	<p>Frequency range: DC to 2 GHz</p> <p>Impedance: 50 <math>\Omega</math></p> <p>Maximum length: 1 meter</p>
SMA (f)-to-N (m) adapter	Fairview Microwave SM4226	Splitter balance characterization	Frequency range: DC to 2 GHz

Instrument	Recommended Model	Where Used	Requirements
		Adjusting internal frequency reference  Adjusting absolute amplitude accuracy	Impedance: 50 $\Omega$  Return loss: $\geq 23$ dB
SMA (m)-to-N (f) adapter	Huber+Suhner 33_SMA_N-50-1/1-_UE or Fairview Microwave SM4241	Splitter balance characterization Adjusting absolute amplitude accuracy	Frequency range: DC to 2 GHz  Impedance: 50 $\Omega$  Return loss: $\geq 23$ dB
SMA (f)-to-N (f) adapter	Huber+Suhner 31_3-SMA-50-1/1-_UE or Fairview Microwave SM4236	Splitter balance characterization	Frequency range: DC to 2 GHz  Impedance: 50 $\Omega$  Return loss: $\geq 23$ dB
3.5 mm (m)-to-3.5 mm (m) adapter	Huber+Suhner 32_PC35-50-0-2/199_NE or Fairview Microwave SM4960	Splitter balance characterization Adjusting absolute amplitude accuracy	Frequency range: DC to 2 GHz  Impedance: 50 $\Omega$  Return loss: $\geq 30$ dB
3.5 mm (f)-to-3.5 mm (f) adapter	Huber+Suhner 31_PC35-50-0-1/199_UE	Splitter balance characterization	Frequency range: DC to 2 GHz  Impedance: 50 $\Omega$  Return loss: $\geq 28$ dB



## Note

- \*Options other than those specified are not supported by NI.
- †Three terminators are included in the PXIe-5668R cable accessory kit.
- ‡Included in the PXIe-5668R cable accessory kit.

## Test Conditions

The following setup and environmental conditions are required to ensure the NI 5668R meets published specifications.

- Keep cabling as short as possible. Long cables and wires act as antennas, picking up extra noise that can affect measurements.
- Verify that all connections, including front panel connections and screws, are secure.
- Maintain an ambient temperature of  $23\text{ }^{\circ}\text{C} \pm 5\text{ }^{\circ}\text{C}$ .
- Keep the relative humidity between 10% and 90%, noncondensing.
- Ensure that the PXI/PXI Express chassis fan speed is set to HIGH and that the empty slots contain filler panels. For more information about maintaining adequate air circulation in your PXI/PXI Express chassis, refer to the **Maintain Forced-Air Cooling Note to Users** document available at [ni.com/docs](http://ni.com/docs).
- Allow a warm-up time of at least 30 minutes after NI-RFSA is loaded and recognizes the NI 5668R. The warm-up time ensures that the measurement circuitry of the NI 5668R is at a stable operating temperature.
- Use a torque wrench appropriate for the type of RF connector that you are using. NI recommends a  $0.565\text{ N}\cdot\text{m}$  (5 lb·in.) wrench for SMA connectors and an  $0.90\text{ N}\cdot\text{m}$  (8 lb·in.) wrench for 2.9 mm connectors.
- Connect the frequency reference source to the REF IN connector on the PXI Express chassis with a standard BNC (m)-to-BNC (m) cable. This connection replaces the connection from the NI 5653 REF OUT (10 MHz) connector to the PXI Express chassis REF IN connector, if present.
- Lock all test equipment to the REF OUT signal on the back of the PXI Express chassis. Refer to the **NI 5668R Timing Configurations** topic in the **NI RF Vector Signal Analyzers Help** for more information about configuring clocking sources.

## Device Setup

Refer to the **PXIe-5668 Getting Started Guide** for information about how to install the software and hardware and how to configure the device in Measurement & Automation Explorer (MAX).



**Note** A warmup begins when the procedure initializes. Warmup may cause indeterminate delay at the YTF Self Alignment step.

1. Install the NI 5668R in the PXI Express chassis according to the instructions in the ***NI RF Signal Generators Getting Started Guide***.
2. Configure the hardware using Measurement & Automation Explorer (MAX). You must create a MAX association between the hardware modules to control them as a single RF device before you can program the device. Complete the following steps to make this association.
  - a. In MAX, select the NI 5606 RF downconverter in the configuration tree.
  - b. In the Associated Devices section, select the appropriate module from each system component drop-down listbox.

For NI 5668R, you must associate the NI 5624R IF digitizer module and the NI 5653 LO source module with the NI 5606 RF downconverter.



**Note** Device associations are lost when you move modules to different chassis slots.

- c. Click **Save** in the MAX toolbar.
3. Launch the Calibration Executive procedure. Calibration Executive guides you through the required connections.

## Connection Diagrams

The following diagram, Figure 1, shows the equipment and connections required for Test System Characterization. Components 2, 4, and 8 in the diagram create a "splitter fixture" that is handled as a single component. Do not alter connections inside this assembly during procedure execution.



**Note** Once Power Sensor B (5) is connected to the 2.92 (f)-to-2.92 (f) adaptor (7), it is recommended to keep them connected. This improves test time and decreases wear on the connectors.

Figure 1. Connections for Test System Characterization

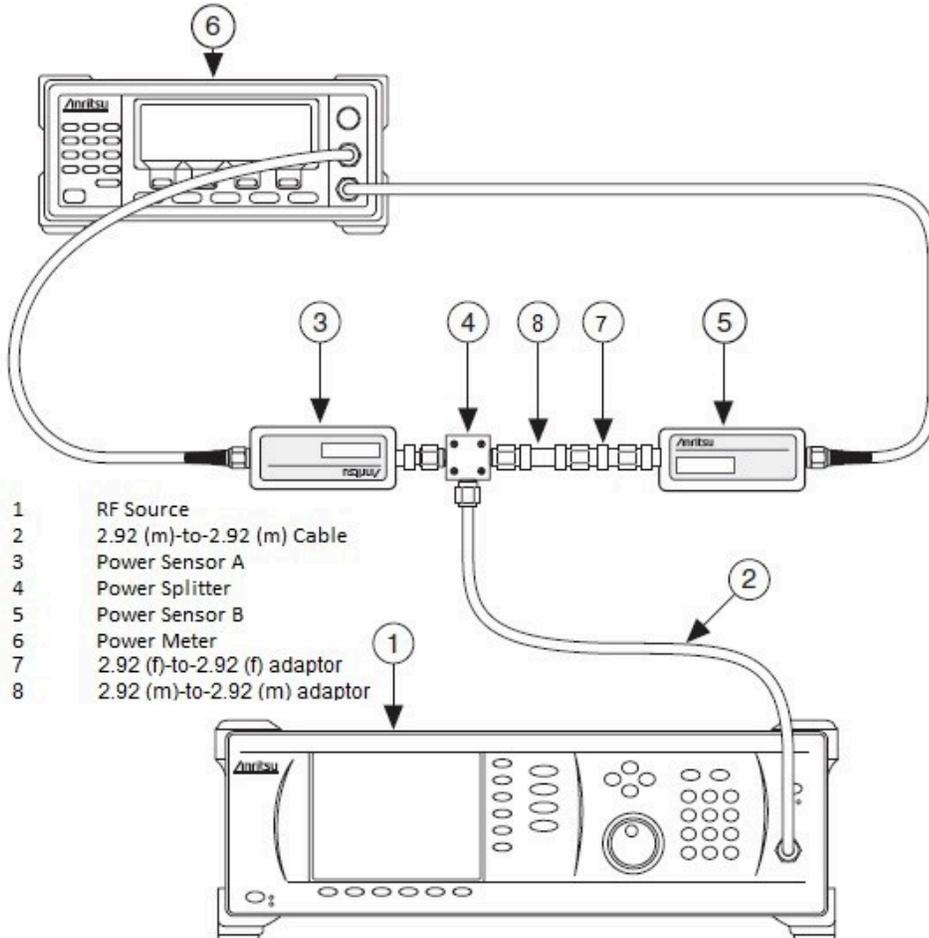

Figure 2 illustrates the connections necessary for characterizing the power splitter reference output. In the figure, components 2, 7, 6 and 5 create a splitter filter fixture with attenuator. Do not alter connections inside this assembly during procedure execution.



**Note** Once the power sensor (9) is connected to the SMA (f)-to-N (m) adaptor (8), it is recommended to keep them connected. This improves test time and decreases wear on the connectors.



**Figure 1.** Connection Diagram for Measuring at Splitter Output

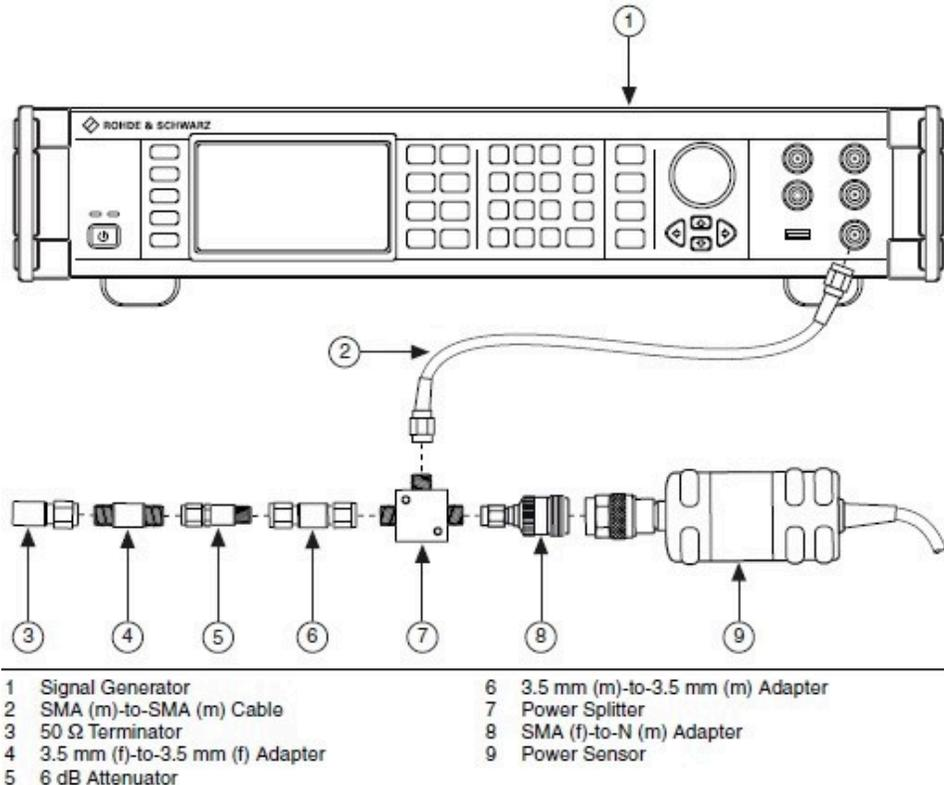

### Related concepts:

- [PXIe-5606 Calibration Procedure](#)
- [PXIe-5624 Calibration Procedure](#)
- [PXIe-5653 Calibration Procedure](#)
- [PXIe-5668R Calibration Procedure](#)

### PXIe-5668R Test Equipment (Verification Only)

The following table lists the test equipment required for calibrating the NI 5668R in Verify Only mode.

Refer to **Test Equipment (Adjust Only)** table for a list of test equipment required for calibrating the NI 5668R in Adjust Only mode. Refer also to test equipment tables for PXIe-5606, PXIe-5624 and PXIe-5653.

## Test Equipment (Verify Only)

**Table 275.** Test equipment for calibrating the PXIe-5668R in Verify Only mode

Instrument	Recommended Model	Where Used	Requirements
Signal source analyzer	Rohde & Schwarz (R&S) FSUP Signal Source Analyzer		<p>Frequency range: 9 MHz to 10 GHz</p> <p>Frequency accuracy: 1 ppb over the frequency range, 900 MHz to 9 GHz recommended</p> <p>Noise floor: &lt; -152 dBm/Hz</p> <p>Phase noise measurement using cross-correlation</p> <p>Frequency counter marker feature</p> <p>Spectrum analysis capabilities</p>
Power meter	Anritsu ML2438A	Verifying absolute amplitude accuracy	<p>Display resolution: <math>\leq 0.01</math> dB</p> <p>Settling: <math>\pm 0.1\%</math></p> <p>Instrumentation accuracy: <math>\leq \pm 0.5\%</math></p> <p>Noise, zero set, and drift: <math>\leq \pm 0.5\%</math> full-scale (lowest range)</p> <p>Reference power uncertainty: <math>\leq \pm 0.12\%</math></p> <p>Reference output VSWR: <math>&lt; 1.12 : 1</math></p>
Power sensor (x2)	Anritsu SC7413	Verifying absolute amplitude accuracy	<p>Power range: -55 dBm to 20 dBm</p> <p>Frequency range: 100 kHz to 26.5 GHz</p> <p>Input VSWR:</p> <ul style="list-style-type: none"> <li>• &lt;150 MHz: <math>&lt; 1.17 : 1</math></li> <li>• 150 MHz to &lt;2 GHz: <math>&lt; 1.08 : 1</math></li> <li>• 2 GHz to &lt;12.4 GHz: <math>&lt; 1.16 : 1</math></li> <li>• 12.4 GHz to &lt;18 GHz: <math>&lt; 1.21 : 1</math></li> </ul>

Instrument	Recommended Model	Where Used	Requirements
			<ul style="list-style-type: none"> <li>• 18 GHz to &lt;32 GHz: &lt;1.29 : 1</li> </ul> <p>Linearity:</p> <ul style="list-style-type: none"> <li>• &lt;18 GHz: &lt;1.8%</li> <li>• &lt;27 GHz: &lt;2.5%</li> </ul> <p>Refer to the <b><i>NI PXIe-5668R Calibration Procedure</i></b> for calibration factor uncertainty (2 <math>\sigma</math>) specifications.</p>
Signal generator (RF source 1)*	<p>Anritsu MG3694C</p> <p>Options 1A, 2B, 4, 22, and 28B</p> <p>Note: Do not use option 15</p>	<p>Verifying third-order intermodulation distortion</p> <p>Verifying gain compression</p> <p>Verifying second harmonic intercept</p>	<p>Frequency range: 10 MHz to 26.5 GHz</p> <p>Leveled power: -50 dBm to 14 dBm</p> <p>Power accuracy: <math>\pm 1.0</math> dB</p> <p>Harmonics:</p> <ul style="list-style-type: none"> <li>• &gt;10 MHz to <math>\leq 100</math> MHz: &lt;-40 dBc</li> <li>• &gt;100 MHz to <math>\leq 2.2</math> GHz: &lt;-50 dBc</li> <li>• &gt;2.2 GHz to <math>\leq 16</math> GHz: &lt;-60 dBc</li> </ul> <p>Nonharmonic spurious:</p> <ul style="list-style-type: none"> <li>• &gt;10 MHz to <math>\leq 2.2</math> GHz: &lt;-60 dBc</li> <li>• &gt;2.2 GHz to <math>\leq 16</math> GHz: &lt;-60 dBc</li> </ul> <p>Output VSWR: &lt;2.0 : 1</p>
Signal generator (RF source 2)*	<p>Anritsu MG3694C</p> <p>Options 1A, 2B, 4, 22, and 28B</p> <p>Note: Do not use option 15</p>	<p>Verifying absolute amplitude accuracy</p> <p>Verifying image rejection</p> <p>Verifying third-</p>	<p>Frequency range: 10 MHz to 26.5 GHz</p> <p>Leveled power: -50 dBm to 9 dBm</p> <p>Power accuracy: <math>\pm 1.0</math> dB</p> <p>Harmonics:</p> <ul style="list-style-type: none"> <li>• &gt;10 MHz to <math>\leq 100</math> MHz: &lt;-40 dBc</li> </ul>

Instrument	Recommended Model	Where Used	Requirements
		<p>order intermodulation distortion</p> <p>Verifying second harmonic intercept</p> <p>Verifying gain compression</p>	<ul style="list-style-type: none"> <li>&gt;100 MHz to ≤2.2 GHz: &lt;-50 dBc</li> <li>&gt;2.2 GHz to ≤20 GHz: &lt;-60 dBc</li> </ul> <p>Nonharmonic spurious:</p> <ul style="list-style-type: none"> <li>&gt;10 MHz to ≤2.2 GHz: &lt;-60 dBc</li> <li>&gt;2.2 GHz to ≤26.9 GHz: &lt;-60 dBc</li> </ul> <p>Output VSWR: &lt;2.0 : 1</p>
50 Ω terminations (x4)†	NI 778353-01	All test steps	<p>Frequency: 18 GHz</p> <div style="border: 1px solid #ccc; padding: 5px; background-color: #f9f9f9;">  <p><b>Note</b> The termination load prevents input port leakage and does not contribute to measurement uncertainty.</p> </div>
PXI Express chassis	PXIe-1075 or PXIe-1085	All test steps	—
PXI Express controller	PXIe-8133 or PXIe-8135	All test steps	—
SMA-to-SMA cable, labeled U†	NI 152637A-01	All test steps	—
SMA-to-SMA cable, labeled V†	NI 152638A-01	All test steps	—
SMA-to-SMA cable, labeled W†	NI 152639A-01	All test steps	—
SMA-to-SMA cable, labeled X†	NI 152640A-01	All test steps	—
SMA-to-SMA	NI 152641A-01	All test steps	—

Instrument	Recommended Model	Where Used	Requirements
cable, labeled Y†			
2.92 mm (m)-to-2.92 mm (m) cables (24 in.) (x3)	—	—	<p>Frequency Range: DC to 26.5 GHz</p> <p>Insertion Loss: <math>\leq 10</math> dB at 26.5 GHz</p> <p>Impedance: 50 <math>\Omega</math></p> <p>VSWR: <math>&lt; 2.0 : 1</math></p>
2.92 mm (m)-to-2.92 mm (m) adaptor	Anritsu K220B	<p>IF Gain Adjustment</p> <p>Lowband RF Response</p> <p>Highband RF Response</p> <p>Test system characterization</p>	<p>Frequency range: DC to 26.5 GHz</p> <p>Impedance: 50 <math>\Omega</math></p> <p>VSWR: <math>&lt; 1.12 : 1</math></p> <p>Return loss:</p> <ul style="list-style-type: none"> <li>DC to 1.5 GHz: <math>\geq 35</math> dB</li> <li>1.5 GHz to 6.0 GHz: <math>\geq 30</math> dB</li> <li>6.0 GHz to 18.0 GHz: <math>\geq 20</math> dB</li> </ul>
2.92 mm (f)-to-2.92 mm (f) adaptor	Fairview Microwave SM4953	<p>LO Output Power</p> <p>Test system characterization</p>	<p>Frequency range: DC to 26.5 GHz</p> <p>Impedance: 50 <math>\Omega</math></p> <p>VSWR: <math>&lt; 1.15 : 1</math></p>
2.92 mm (m)-to-2.92 mm (f) 20 dB attenuator	Anritsu 41KC-20	—	<p>Frequency range: DC to 26.5 GHz</p> <p>Attenuation: 20 dB (nominal)</p> <p>Power rating: 2 W average</p> <p>Impedance: 50 <math>\Omega</math></p> <p>VSWR:</p> <ul style="list-style-type: none"> <li>DC to 12 GHz: <math>\leq 1.1 : 1</math></li> </ul>

Instrument	Recommended Model	Where Used	Requirements
			<ul style="list-style-type: none"> <li>• 12 GHz to 18 GHz: <math>\leq 1.15 : 1</math></li> <li>• 18 GHz to 26.5 GHz: <math>\leq 1.2 : 1</math></li> </ul>
Power splitter (two-resistor type)	Aeroflex/ Weinschel 1534	IF Gain Adjustment  Lowband RF Response  Highband RF Response  Test system characterization	Frequency range: DC to 26.5 GHz  Amplitude tracking: $< 0.3$ dB  Phase tracking: $< 2^\circ$  Insertion loss: $\leq 8.0$ dB (6 dB, nominal)  Power rating: 1 W  Impedance: 50 $\Omega$  VSWR: <ul style="list-style-type: none"> <li>• DC to 26.5 GHz: <math>\leq 1.4 : 1</math></li> </ul> Equivalent output VSWR: <ul style="list-style-type: none"> <li>• DC to 26.5 GHz: <math>\leq 1.35 : 1</math></li> </ul> Connectors: 2.92 mm (f)
Anti-distortion test fixture	NI 538381A-01	Verifying third-order intermodulation distortion  Verifying second harmonic intercept  Verifying gain compression	Refer to the <b>PXIe-5668R Calibration Procedure</b> for anti-distortion test fixture specifications. <div style="border: 1px solid #ccc; padding: 5px; margin-top: 10px;">  <p><b>Note</b> The anti-distortion test fixture requires an external +15 V/75W supply and USB interface. Contact NI for programming details.</p> </div>
Frequency reference source	Symmetricom 8040C rubidium frequency	All test steps	Frequency: 10 MHz Frequency accuracy: $\leq 1 \times 10^{-9}$

Instrument	Recommended Model	Where Used	Requirements
	standard		
Torque wrench	—	—	Refer to <b>Test Conditions</b> for torque wrench specifications.



## Note

- \*Options other than those specified are not supported by NI.
- †Included in the PXIe-5668R cable accessory kit.

## Test Conditions

The following setup and environmental conditions are required to ensure the NI 5668R meets published specifications.

- Keep cabling as short as possible. Long cables and wires act as antennas, picking up extra noise that can affect measurements.
- Verify that all connections, including front panel connections and screws, are secure.
- Maintain an ambient temperature of  $23\text{ °C} \pm 5\text{ °C}$ .
- Keep the relative humidity between 10% and 90%, noncondensing.
- Ensure that the PXI/PXI Express chassis fan speed is set to HIGH and that the empty slots contain filler panels. For more information about maintaining adequate air circulation in your PXI/PXI Express chassis, refer to the **Maintain Forced-Air Cooling Note to Users** document available at [ni.com/docs](http://ni.com/docs).
- Allow a warm-up time of at least 30 minutes after NI-RFSA is loaded and recognizes the NI 5668R. The warm-up time ensures that the measurement circuitry of the NI 5668R is at a stable operating temperature.
- Use a torque wrench appropriate for the type of RF connector that you are using. NI recommends a  $0.565\text{ N} \cdot \text{m}$  (5 lb · in.) wrench for SMA connectors and an  $0.90\text{ N} \cdot \text{m}$  (8 lb · in.) wrench for 2.9 mm connectors.
- Connect the frequency reference source to the REF IN connector on the PXI Express chassis with a standard BNC (m)-to-BNC (m) cable. This connection replaces the connection from the NI 5653 REF OUT (10 MHz) connector to the PXI Express

chassis REF IN connector, if present.

- Lock all test equipment to the REF OUT signal on the back of the PXI Express chassis. Refer to the ***NI 5668R Timing Configurations*** topic in the ***NI RF Vector Signal Analyzers Help*** for more information about configuring clocking sources.

## Device Setup

Refer to the ***PXIe-5668 Getting Started Guide*** for information about how to install the software and hardware and how to configure the device in Measurement & Automation Explorer (MAX).



**Note** A warmup begins when the procedure initializes. Warmup may cause indeterminate delay at the YTF Self Alignment step.

1. Install the NI 5668R in the PXI Express chassis according to the instructions in the ***NI RF Signal Generators Getting Started Guide***.
2. Configure the hardware using Measurement & Automation Explorer (MAX). You must create a MAX association between the hardware modules to control them as a single RF device before you can program the device. Complete the following steps to make this association.
  - a. In MAX, select the NI 5606 RF downconverter in the configuration tree.
  - b. In the Associated Devices section, select the appropriate module from each system component drop-down listbox.

For NI 5668R, you must associate the NI 5624R IF digitizer module and the NI 5653 LO source module with the NI 5606 RF downconverter.



**Note** Device associations are lost when you move modules to different chassis slots.

- c. Click **Save** in the MAX toolbar.
3. Launch the Calibration Executive procedure. Calibration Executive guides you through the required connections.

**Related concepts:**



- [PXIe-5606 Calibration Procedure](#)
- [PXIe-5624 Calibration Procedure](#)
- [PXIe-5653 Calibration Procedure](#)
- [PXIe-5668R Calibration Procedure](#)

## PXIe-5667 Calibration Procedure

Calibrate the PXIe-5667 3.6 GHz and 7 GHz modules using Calibration Executive.

### Calibration Executive Procedure Features

Verify Only ✓	Verify & Adjust ✓	Manual Mode ✗	Optional Adjust ✗
---------------	-------------------	---------------	-------------------

### Approximate Test Time

Device	Verify Only	Verify & Adjust
PXIe-5667 (3.6 GHz)	10 minutes	110 minutes
PXIe-5667 (7 GHz)	10 minutes	140 minutes

### Test Equipment

The following table lists the test equipment required for calibrating PXIe-5667 modules.

**Table 276.** Test equipment for calibrating the PXIe-5667

Instrument	Recommended Model	Requirements
Power meter	Anritsu ML2438A	Display resolution: $\leq 0.01$ dB Settling: $\pm 0.1\%$ Instrumentation accuracy: $< \pm 0.5\%$ Noise, zero set, and drift: $< \pm 0.5\%$ full-scale (lowest range) Reference power uncertainty: $< \pm 0.9\%$

Instrument	Recommended Model	Requirements
		Reference output VSWR: <1.04
Power sensor A	Anritsu MA2473D	<p>Power sensor</p> <p>Power range: -60 dBm to 20 dBm</p> <p>Frequency range: 10 MHz to 18 GHz</p> <p>Input VSWR:</p> <ul style="list-style-type: none"> <li>• 10 MHz to 50 MHz: &lt;1.90</li> <li>• 50 MHz to 2 GHz: &lt;1.12</li> <li>• 2 GHz to 8 GHz: &lt;1.22</li> </ul> <p>Linearity: -60 dBm to 20 dBm: &lt;1.8%</p> <p>Calibration factor uncertainty:</p> <ul style="list-style-type: none"> <li>• 10 MHz to 50 MHz: &lt;1.9%</li> <li>• 50 MHz to 500 MHz: &lt;1.5%</li> <li>• 500 MHz to 7 GHz: &lt;1.5%</li> <li>• 7 GHz to 8 GHz: &lt;1.9%</li> </ul>
Power sensor B	Anritsu Ma2421	<p>Power sensor</p> <p>Power range: -50 dBm to 20 dBm</p> <p>Frequency range: 100 kHz to 18 GHz</p> <p>Input VSWR:</p> <ul style="list-style-type: none"> <li>• 10 MHz to 50 MHz: &lt;1.90</li> <li>• 50 MHz to 2 GHz: &lt;1.12</li> <li>• 2 GHz to 8 GHz: &lt;1.22</li> </ul> <p>Linearity:</p> <ul style="list-style-type: none"> <li>• -60 dBm to 20 dBm: &lt;1.8%</li> <li>• Calibration factor uncertainty:</li> <li>• 10 MHz to 50 MHz: &lt;1.9%</li> </ul>

Instrument	Recommended Model	Requirements
		<ul style="list-style-type: none"> <li>• 50 MHz to 500 MHz: &lt;1.5%</li> <li>• 500 MHz to 7 GHz: &lt;1.5%</li> <li>• 7 GHz to 8 GHz: &lt;1.9%</li> </ul>
Spectrum Analyzer	Rohde & Schwarz FSUP26	Frequency Range: 10 MHz to 10 GHz
Signal generator (RF source)	<p>Anritsu MG3692C</p> <p>Options 2A, 3, 4, 15A, and 22</p>	<p>Frequency range: 7 MHz to 8 GHz</p> <p>Frequency accuracy: &lt;0.2 ppm</p> <p>Leveled power: -115 dBm to 18 dBm</p> <p>Power accuracy: <math>\pm 1.5</math> dB</p> <p>Harmonics:</p> <ul style="list-style-type: none"> <li>• 0.1 MHz to <math>\leq 10</math> MHz: &lt;-30 dBc</li> <li>• &gt;10 MHz to <math>\leq 100</math> MHz: &lt;-40 dBc</li> <li>• &gt;100 MHz to <math>\leq 2.2</math> GHz: &lt;-50 dBc</li> <li>• &gt;2.2 GHz to <math>\leq 8</math> GHz: &lt;-30 dBc</li> </ul> <p>Nonharmonic spurious:</p> <ul style="list-style-type: none"> <li>• 0.1 MHz to <math>\leq 10</math> MHz: &lt;-30 dBc</li> <li>• &gt;10 MHz to <math>\leq 2.2</math> GHz: &lt;-60 dBc</li> <li>• &gt;2.2 GHz to <math>\leq 8</math> GHz: &lt;-60 dBc</li> <li>• Output VSWR: &lt;2.0</li> </ul>
Three SMA (m)-to-SMA (m) semi-rigid cables*	NI 151611A-01	—
SMA (m)-to-SMA (m) semi-rigid cable	<p>NI 154049A-01 (if using PXIe-5667 3.6 GHz)</p> <p>NI 154050A-01 (if using PXIe-5667 7 GHz)</p>	—
Two SMA (m)-to-SMA (m) semi-rigid cables	NI 154048A-01	—
Two SMA (m)-to-SMA (m) semi-flexible cables	NI 763282-07	—

Instrument	Recommended Model	Requirements
SMA (m)-to-BNC (m) cable	NI 151890A-1R25	—
SMA (m)-to-SMA (m) cable (36 in.)	MegaPhase G916-SISI-36	<p>Frequency range: DC to 8 GHz</p> <p>Insertion loss: <math>\leq 2</math> dB at 8 GHz</p> <p>Impedance: 50 <math>\Omega</math></p> <p>VSWR: <math>\leq 1.35</math> at 8 GHz</p>
3.5 mm (m)-to-3.5 mm (m) adapter	Huber+Suhner 32_Pc35-50-0-2/199_NE	<p>Frequency range: DC to 8 GHz</p> <p>Impedance: 50 <math>\Omega</math></p> <p>Return loss:</p> <ul style="list-style-type: none"> <li>• DC to 1.5 GHz: <math>\geq 35</math> dB</li> <li>• 1.5 GHz to 6 GHz: <math>\geq 30</math> dB</li> <li>• 6 GHz to 8 GHz: <math>\geq 20</math> dB</li> </ul>
3.5 mm (f)-to-3.5 mm (f) adapter	Huber+Suhner 31_Pc35-50-0-2/199_N	<p>Frequency range: DC to 8 GHz</p> <p>Impedance: 50 <math>\Omega</math></p> <p>Return loss:</p> <ul style="list-style-type: none"> <li>• DC to 1.5 GHz: <math>\geq 35</math> dB</li> <li>• 1.5 GHz to 6 GHz: <math>\geq 30</math> dB</li> <li>• 6 GHz to 8 GHz: <math>\geq 20</math> dB</li> </ul>
SMA (m)-to-SMA (f) 20 dB attenuator	Huber+Suhner 6620_SMA-50-1/199N	<p>Frequency range: DC to 8 GHz</p> <p>Attenuation: 20 dB (nominal)</p> <p>Power rating: 2 W average</p> <p>Impedance: 50 <math>\Omega</math></p> <p>VSWR:</p> <ul style="list-style-type: none"> <li>• DC to 4 GHz: <math>\leq 1.15</math></li> </ul>

Instrument	Recommended Model	Requirements
		<ul style="list-style-type: none"> <li>4 GHz to 8 GHz: <math>\leq 1.20</math></li> </ul>
Power splitter (two-resistor type)	Aeroflex/Weinschel 1593	Frequency range: DC to 8 GHz Amplitude tracking: $< 0.25$ dB Phase tracking: $< 4^\circ$ Insertion loss: $\leq 8.5$ dB (6 dB, nominal) Power rating: 1 W Impedance: 50 $\Omega$ VSWR: DC to 8 GHz: $\leq 1.25$ Equivalent output VSWR: <ul style="list-style-type: none"> <li>DC to 8 GHz: <math>\leq 1.25</math></li> <li>Connectors: 3.5 mm (f)</li> </ul>
Torque wrench	—	Refer to <b>Test Conditions</b> for torque wrench specifications.



**Note** \*Included in the PXIe-5667 cable accessory kit.

## Test Conditions

The following setup and environmental conditions are required to ensure the NI 9263 meets published specifications.

- Keep cabling as short as possible. Long cables and wires act as antennas, picking up extra noise that can affect measurements.
- Verify that all connections, including front panel connections and screws, are secure.
- Maintain an ambient temperature of  $23\text{ }^\circ\text{C} \pm 5\text{ }^\circ\text{C}$ .
- Keep the relative humidity between 10% and 90%, noncondensing.

- Ensure that the PXI/PXI Express chassis fan speed is set to HIGH and that the empty slots contain filler panels. For more information about maintaining adequate air circulation in your PXI/PXI Express chassis, refer to the ***Maintain Forced-Air Cooling Note to Users*** document available at [ni.com/docs](http://ni.com/docs).
- Allow a warm-up time of at least 30 minutes after NI-RFSA is loaded and recognizes the PXIe-5667. The warm-up time ensures that the measurement circuitry of the PXIe-5667 is at a stable operating temperature.
- Use a torque wrench appropriate for the type of RF connector that you are using. NI recommends a 0.565 N · m (5 lb · in.) wrench for SMA connectors and an 0.90 N · m (8 lb · in.) wrench for 3.5 mm connectors.
- Connect the Signal Generator Reference Out to the REF IN connector on the back of the PXI Express chassis with a standard BNC (m)-to-BNC (m) cable.
- Perform self-calibration on the PXIe-5667.

## Device Setup

Refer to the NI 5667 (3.6 GHz) Spectrum Monitoring Receiver Getting Started Guide or the NI 5667 (7 GHz) Spectrum Monitoring Receiver Getting Started Guide for information about how to install the software and hardware and how to configure the device in Measurement & Automation Explorer (MAX).

1. Install the PXIe-5667 in the PXI Express chassis according to the instructions in the NI RF Signal Generators Getting Started Guide.
2. Configure the hardware using Measurement & Automation Explorer (MAX). You must create a MAX association between the hardware modules to control them as a single RF device before you can program the device. Complete the following steps to make this association.
  - a. Right-click the RF downconverter or the PXIe-5667 in MAX and select **Configure**.
  - b. In the **Configuration** dialog box, select the appropriate module from each system component listbox.
3. Launch the Calibration Executive procedure. Calibration Executive guides you



**Note** Device associations are lost when you move modules to different chassis slots.

- c. Click **OK** to exit the dialog box.

through the required connections.

### Related concepts:

- [Launching a Calibration Procedure](#)

## PXIe-5673/5673E Calibration Procedure

Calibrate the PXIe-5673/5673E using Calibration Executive.

### Calibration Executive Procedure Features

Verify Only ✓	Adjust Only ✓	Verify & Adjust ✓	Manual Mode ✓	Optional Adjust ✗
---------------	---------------	-------------------	---------------	-------------------

### Approximate Test Time

Verify Only	Adjust Only	Verify & Adjust
45 minutes	270 minutes	280 minutes



**Note** Verify Only is the only supported run mode for the 3.3 GHz version of the PXIe-5673E.



**Note** Calibration Executive only supports PXIe-5673/5673E devices that consist of an NI 5611, NI 5450, and NI 5652.

### Test Equipment

The following table lists the test instruments required for calibrating the PXIe-5673/5673E.

**Table 277.** Test equipment for calibrating the PXIe-5673/5673E

Instrument	Recommended Model	Requirements	Verification Parameter Measured	Run Modes
Spectrum	Rohde & Schwarz FSU Spectrum	Frequency	Modulation	Verify

Instrument	Recommended Model	Requirements	Verification Parameter Measured	Run Modes
Analyzer	Analyzer with required options FSU-B23 (20 dB preamplifier) and FSU-B25 (electronic attenuator).	range: 500 kHz to 19.8 GHz  Noise floor: <-152 dBm/Hz to 6.6 GHz	impairments  Modulation bandwidth and impairments,  Output power level accuracy,  Output intermodulation products,  Noise floor, RF harmonics,  Baseband linearity-related spurs,  Single-sideband phase noise,  Frequency accuracy	Only, Verify & Adjust, Adjust Only
Frequency Reference	Datum 8040 Rubidium Frequency Standard	Frequency: 10 MHz  Frequency accuracy: 1 ppb (typically $\pm 5E-11$ )	—	—
Power Meter	Anritsu ML2438A	Accuracy: 0.5%	LO output power,  Output power level accuracy	Verify Only, Verify & Adjust, Adjust



Instrument	Recommended Model	Requirements	Verification Parameter Measured	Run Modes
				Only
Diode Power Sensor (Connected to Port A of the Anritsu Power Meter)	Ma2472 diode sensor	Range: -70 dBm to +20 dBm  Frequency range: 10 MHz to 6.6 GHz	LO output power  Output power level,  Accuracy	Verify Only, Verify & Adjust, Adjust Only
Thermal Power Sensor (Connected to Port B of the Anritsu Power Meter)	Ma2421 thermal sensor	Range: -30 dBm to +20 dBm  Frequency range: 500 kHz to 10 MHz	—	Verify & Adjust, Adjust Only
USB Power Meter/ Sensor (x2)	Rohde & Schwarz NRP-Z91 with NRP-Z4 USB adapter	VSWR (50 kHz to 120 MHz): $\leq 1.11$  Relative Power Accuracy: $\leq 0.022$ dB	—	Verify & Adjust, Adjust Only
DMM	PXI-4071	DCV Accuracy: $\leq 0.05\%$ DCV  Input Impedance: $\geq 1$ G $\Omega$ ACV  Accuracy: $\leq 0.13\%$ ACV	—	Verify & Adjust, Adjust Only

Instrument	Recommended Model	Requirements	Verification Parameter Measured	Run Modes
		Input Impedance: $\geq 10$ M $\Omega$ Bandwidth: $\geq 100$ kHz		
Power Splitter	Aeroflex/Weinschel 1593	SWR: 1.25 Amplitude tracking: $< 0.25$ dB	—	—
7 dB Attenuator (x2)	Mini-Circuits VAT-7-1+ Attenuators	VSWR (50 kHz to 120 MHz): 1.02:1 Flatness (50 kHz to 60 MHz): 0.05 dB Flatness (60 MHz to 120 MHz): 0.07 dB	—	Verify & Adjust, Adjust Only
6 dB Attenuator	Anritsu 41KB-6	Frequency Range: DC to 12 GHz SWR: 1.1	—	—
50 $\Omega$ Terminator	NI SMA 50 $\Omega$ Termination Plug (778353-01)	—	—	—
Type N(f) to SMA(m) Adapter	S.M. Electronics Sm4241	VSWR: 1.15: 1	—	—

Instrument	Recommended Model	Requirements	Verification Parameter Measured	Run Modes
SMA Adapter Plug/Plug	Huber+Suhner 32_N-SMA-50-1/11-_NE	VSWR: 1.05: 1	—	—
SMA Torque Wrench	NI RF Torque Wrench	1 N · m	—	—
Connection Accessory	PXIe-5673/5673E Cable Accessory Kit	—	—	—
BNC(m) to BNC(m) Cable	—	Use a cable that is 36 inches in length	—	—
BNC(m) to SMA(m) Cable	—	Use a cable that is 36 inches in length	—	—
Chassis	PXIe-1065, PXIe-1075	—	—	—
Chassis Controller	NI MXI-Express Kit	—	—	—



**Note** NI strongly recommends using the instruments specified above when calibrating the PXIe-5673/5673E module. Substitution of instruments is permitted by Calibration Executive software, but NI cannot guarantee that unsupported instruments meet the specifications required for calibration.

## Test Conditions

The following setup and environmental conditions are required to ensure the PXIe-5673/5673E meets published specifications.

- Verify that the NI 5611, NI 5450, and NI 5652 are properly connected as indicated in the NI RF Signal Generators Getting Started Guide.
- Keep cabling as short as possible. Long cables act as antennas, picking up extra noise that can affect measurements.
- Verify that all connections, including front panel connections and screws, are secure.

- Ensure that the PXI Express chassis fan speed is set to HIGH, that the fan filters are clean, and that the empty slots contain filler panels. For more information, refer to the Maintain Forced-Air Cooling Note to Users document available at [ni.com/docs](http://ni.com/docs).
- Keep relative humidity between 10% and 90%, noncondensing.
- Maintain an ambient temperature of  $23 \pm 5$  °C.
- Allow a warm-up time of at least 30 minutes after the chassis is powered on. The warm-up time ensures that the PXIe-5673/5673E is at a stable operating temperature.



**Notice** Incorrect torque at SMA connections can degrade signal fidelity, PLL performance, and insertion loss. Use an SMA torque wrench or torque screwdriver to ensure all SMA connections are properly torqued to 1 N · m.

## Device Setup

1. Install the PXIe-5673/5673E in the PXI Express chassis according to the instructions in the NI RF Signal Generators Getting Started Guide.
2. Configure the hardware using Measurement & Automation Explorer (MAX). You must create a MAX association between the NI 5611 I/Q modulator module, the NI 5450 AWG module, and the NI 5650/5651/5652 LO source module to control all three hardware modules as a single NI RF vector signal generator. Complete the following steps to make this association.
  - a. Right-click **NI PXIe-5611** and select **Properties**.
  - b. In the NI 5611 Device Properties dialog box, use the AWG drop-down listbox to select the NI 5450 module that is connected to the NI 5611 by front panel coaxial cables.
  - c. In the NI 5611 Device Properties dialog box, use the drop-down LO listbox to specify the NI 5650/5651/5652 module that is connected to the NI 5611 by front panel coaxial cables.



**Note** NI RF vector signal generators allow the use of an LO other than the NI 5650/5651/5652 or daisy-chaining the same LO signal from one NI 5611 to another NI 5611. These exceptions are referred to as an external LO. Refer to the NI RF Signal Generators Help for more information about configuring and using an external LO.

- Launch the Calibration Executive procedure. Calibration Executive guides you through the required connections.



**Note** During the calibration procedure, the 565x ALC Limits Table is validated to ensure the device is operating properly. Refer to Understanding Validate ALC Limits Table Results for information about ALC Limits Table validation.

### Related concepts:

- [Launching a Calibration Procedure](#)
- [NI 5650/5651/5652 Calibration Procedure](#)

## PXIe-5693 Calibration Procedure

Calibrate the PXIe-5693 using Calibration Executive.

### Calibration Executive Procedure Features

Verify Only ✓	Verify & Adjust ✓	Manual Mode ✗	Optional Adjust ✗
---------------	-------------------	---------------	-------------------

### Approximate Test Time

Verify Only	Verify & Adjust
40 minutes	140 minutes

### Test Equipment

The following table lists the test equipment required for calibrating PXIe-5693 modules.

**Table 312.** Test equipment for calibrating the PXIe-5693

Instrument	Recommended Model	Where Used	Requirements
Noise source	NoiseCom NC346B Precision	Noise figure verification	Frequency: 10 MHz to 8 GHz

Instrument	Recommended Model	Where Used	Requirements
			Output ENR: 14 dB to 16 dB  VSWR: 1.25
Spectrum analyzer	Rohde & Schwarz FSU26 with required options FSU-B23 (20 dB preamplifier) and FSU-B25 (electronic attenuator)	Test system characterization  Verifications: <ul style="list-style-type: none"> <li>• Noise figure</li> <li>• In-band third order intercept</li> <li>• Out-of-band third order intercept</li> <li>• Reverse isolation</li> </ul>	Frequency range: 20 MHz to 8 GHz  Internal preamplifier  Noise source control (28 V supply, BNC connector)
Power meter	Anritsu ML2438A	Test system characterization  Verifications: <ul style="list-style-type: none"> <li>• In-band third order intercept</li> <li>• Out-of-band third order intercept</li> <li>• Reverse isolation</li> <li>• Calibration signal amplitude</li> </ul>	Display resolution: ≤0.01 dB  Settling: ±0.1%  Instrumentation accuracy: <±0.5%  Noise, zero set, and drift: ≤±0.5% full-scale (lowest range)  Reference power uncertainty: ≤±0.9%

Instrument	Recommended Model	Where Used	Requirements
		<p>accuracy</p> <p>Adjustments:</p> <ul style="list-style-type: none"> <li>• RF gain</li> <li>• Calibration tone power accuracy</li> </ul>	<p>Reference output VSWR: &lt;1.04</p>
<p>Power sensor A</p> <p>Power sensor B</p>	<p>Anritsu MA2473D</p>	<p>Test system characterization</p> <p>Verifications:</p> <ul style="list-style-type: none"> <li>• In-band third order intercept</li> <li>• Out-of-band third order intercept</li> <li>• Reverse isolation</li> <li>• Calibration signal amplitude accuracy</li> </ul> <p>Adjustments:</p> <ul style="list-style-type: none"> <li>• RF gain</li> <li>• Calibration tone power accuracy</li> </ul>	<p>Power sensor</p> <p>Power range: -55 dBm to 20 dBm</p> <p>Frequency range: 10 MHz to 8 GHz</p> <p>Input VSWR:</p> <ul style="list-style-type: none"> <li>• 10 MHz to 50 MHz: &lt;1.90</li> <li>• 50 MHz to 2 GHz: &lt;1.12</li> <li>• 2 GHz to 8 GHz: &lt;1.22</li> </ul> <p>Linearity:</p> <ul style="list-style-type: none"> <li>• -60 dBm to 20 dBm: &lt;1.8%</li> </ul> <p>Calibration factor uncertainty:</p> <ul style="list-style-type: none"> <li>• 10 MHz to 50 MHz: &lt;1.9%</li> <li>• 50 MHz to</li> </ul>

Instrument	Recommended Model	Where Used	Requirements
			<p>500 MHz: &lt;1.5%</p> <ul style="list-style-type: none"> <li>• 500 MHz to 7 GHz: &lt;1.5%</li> <li>• 7 GHz to 8 GHz: &lt;1.9%</li> </ul>
<p>Signal generator (RF source 1) (RF source 2)</p>	<p>Anritsu MG3692C Options 2A, 3, 4, 15A, and 22</p>	<p>Test system characterization</p> <p>Verifications:</p> <ul style="list-style-type: none"> <li>• In-band third order intercept</li> <li>• Out-of-band third order intercept</li> <li>• Reverse isolation</li> <li>• Calibration signal amplitude accuracy</li> </ul> <p>Adjustments:</p> <ul style="list-style-type: none"> <li>• RF gain</li> <li>• Calibration tone power accuracy</li> </ul>	<p>Frequency range: 8 MHz to 8 GHz</p> <p>Leveled power: -115 dBm to 18 dBm</p> <p>Power accuracy: ±1.5 dB</p> <p>Harmonics:</p> <ul style="list-style-type: none"> <li>• 0.1 MHz to ≤10 MHz: &lt;-30 dBc</li> <li>• &gt;10 MHz to ≤100 MHz: &lt;-40 dBc</li> <li>• &gt;100 MHz to ≤2.2 GHz: &lt;-50 dBc</li> <li>• &gt;2.2 GHz to ≤8 GHz: &lt;-30 dBc</li> </ul> <p>Nonharmonic Spurious:</p> <ul style="list-style-type: none"> <li>• 0.1 MHz to ≤10 MHz: &lt;-30 dBc</li> <li>• &gt;10 MHz to ≤2.2 GHz:</li> </ul>



Instrument	Recommended Model	Where Used	Requirements
			<p>&lt;-60 dBc</p> <ul style="list-style-type: none"> <li>• &gt;2.2 GHz to ≤8 GHz: &lt;-60 dBc</li> </ul> <p>Output VSWR: &lt;2.0</p>
Four SMA (m)-to-SMA (m) cables (36 in.)	MegaPhase G916-SISI-36	—	<p>Frequency range: DC to 8 GHz</p> <p>Insertion loss: ≤2 dB at 8 GHz</p> <p>Impedance: 50 Ω</p> <p>VSWR: ≤1.35 at 8 GHz</p>
SMA (f)-to-SMA (m) semi-rigid cable (1.08 in. with slight angle bend)	Rosenberger 166782A-01	—	Frequency range: DC to 8 GHz
Two BNC (m)-to-BNC (m) cables (36 in.)	NI 763485-01	Noise figure verification	—
Two BNC (m)-to-BNC (m) cables	—	—	—
SMA (m)-to-SMA (m) adapter	Huber+Suhner 32_SMA-50-0-52/199_NE	<p>Verifications:</p> <ul style="list-style-type: none"> <li>• In-band third order intercept</li> <li>• Out-of-band third order intercept</li> <li>• Reverse isolation</li> </ul>	<p>Frequency range: DC to 8 GHz</p> <p>VSWR: &lt;1.14</p>

Instrument	Recommended Model	Where Used	Requirements
		<ul style="list-style-type: none"> <li>• Calibration signal amplitude accuracy</li> </ul> <p>Adjustments:</p> <ul style="list-style-type: none"> <li>• RF gain</li> <li>• Calibration tone power accuracy</li> </ul>	
SMA (f)-to-SMA (f) adapter	Huber+Suhner 31_SMA-50-0-1/111_NE	Noise figure verification	Frequency range: DC to 8 GHz
SMA (m)-to-SMA (f) 10 dB attenuator	Huber+Suhner 6610_SMA-50-1/199N	<p>Test system characterization</p> <p>Verifications:</p> <ul style="list-style-type: none"> <li>• In-band third order intercept</li> <li>• Out-of-band third order intercept</li> <li>• Reverse isolation</li> </ul>	<p>Frequency range: DC to 8 GHz</p> <p>Attenuation: 10 dB (nominal)</p> <p>Power rating: 2 W average</p> <p>Impedance: 50 Ω</p> <p>VSWR:</p> <ul style="list-style-type: none"> <li>• DC to 4 GHz: ≤1.15</li> <li>• 4 GHz to 8 GHz: ≤1.20</li> </ul>
SMA (m)-to-SMA (f) 20 dB attenuator	Huber+Suhner 6620_SMA-50-1/199N	<p>Test system characterization</p> <p>Verifications:</p> <ul style="list-style-type: none"> <li>• In-band third order</li> </ul>	<p>Frequency range: DC to 8 GHz</p> <p>Attenuation: 20 dB (nominal)</p> <p>Power rating: 2 W</p>

Instrument	Recommended Model	Where Used	Requirements
		intercept • Out-of-band third order intercept intercept • Reverse isolation • Calibration signal amplitude accuracy	average Impedance: 50 Ω VSWR: • DC to 4 GHz: ≤1.15 • 4 GHz to 8 GHz: ≤1.20
SMA (m)-to-SMA (f) 6 dB attenuator	Anritsu 41KB-6	Test system characterization  Calibration signal amplitude accuracy verification  Adjustments: • RF gain • Calibration tone power accuracy	Frequency range: DC to 8 GHz Attenuation: 6 dB Power rating: 2 W average
Power splitter (Two-Resistor Type)	Aeroflex/Weinschel 1593	Test system characterization  Verifications: • In-band third order intercept • Out-of-band third	Frequency range: DC to 8 GHz Amplitude tracking: <0.25 dB Phase tracking: <4° Insertion loss: ≤8.5 dB (6 dB,

Instrument	Recommended Model	Where Used	Requirements
		<p>order intercept</p> <ul style="list-style-type: none"> <li>• Reverse isolation</li> <li>• Calibration signal amplitude accuracy</li> </ul> <p>Adjustments:</p> <ul style="list-style-type: none"> <li>• RF gain</li> <li>• Calibration tone power accuracy</li> </ul>	<p>nominal)</p> <p>Power rating: 1 W</p> <p>Impedance: 50 Ω</p> <p>VSWR:</p> <ul style="list-style-type: none"> <li>• DC to 8 GHz: ≤1.25</li> </ul> <p>Equivalent output VSWR:</p> <ul style="list-style-type: none"> <li>• DC to 8 GHz: ≤1.25</li> </ul> <p>Connectors: 3.5 mm (f)</p>
<p>Low frequency power combiner</p>	<p>Mini Circuits ZFSC-2-5-S+</p>	<p>Test system characterization</p> <p>Verifications:</p> <ul style="list-style-type: none"> <li>• In-band third order intercept</li> <li>• Out-of-band third order intercept</li> </ul>	<p>Frequency range: 10 MHz to 1.5 GHz</p> <p>Isolation:</p> <ul style="list-style-type: none"> <li>• 10 MHz to 100 MHz: ≥15 dB</li> <li>• 100 MHz to 750 MHz: ≥20 dB</li> <li>• 750 MHz to 1.5 GHz: ≥18 dB</li> </ul> <p>Insertion loss:</p> <ul style="list-style-type: none"> <li>• 10 MHz to 100 MHz: ≤3.6 dB</li> <li>• 100 MHz to</li> </ul>

Instrument	Recommended Model	Where Used	Requirements
			750 MHz: $\leq 4.0$ dB <ul style="list-style-type: none"> <li>750 MHz to 1.5 GHz:  <math>\leq 4.5</math> dB</li> </ul> Connectors: SMA (f)
High frequency power combiner	Agilent 87302C	Test system characterization  Verifications: <ul style="list-style-type: none"> <li>In-band third order intercept</li> <li>Out-of-band third order intercept</li> </ul>	Frequency range: 500 MHz to 8 GHz Isolation: <ul style="list-style-type: none"> <li>500 MHz to 8 GHz: <math>\geq 19</math> dB</li> </ul> Insertion loss: <ul style="list-style-type: none"> <li>500 MHz to 8 GHz:  <math>\leq 4.5</math> dB</li> </ul> Connectors: 3.5 mm (f)
Torque wrench	—	—	Refer to for torque wrench specifications.

## Test Conditions

The following setup and environmental conditions are required to ensure the PXIe-5693 meets published specifications.

- Keep cabling as short as possible. Long cables and wires act as antennas, picking up extra noise that can affect measurements.
- Verify that all connections, including front panel connections and screws, are secure.

- Maintain an ambient temperature of  $23\text{ }^{\circ}\text{C} \pm 5\text{ }^{\circ}\text{C}$ .
- Keep the relative humidity between 10% and 90%, noncondensing.
- Ensure that the PXI Express chassis fan speed is set to HIGH, that the fan filters, if present, are clean, and that the empty slots contain filler panels. For more information about maintaining adequate air circulation in your PXI/PXI Express chassis, refer to the **Maintain Forced-Air Cooling Note to Users** document available at [ni.com/docs](http://ni.com/docs).
- Allow a warm-up time of at least 30 minutes after the chassis is powered on and NI-RFSA is loaded and recognizes the PXIe-5693. The warm-up time ensures that the PXIe-5693 and test instrumentation are at a stable operating temperature.
- Use a torque wrench appropriate for the type of RF connector that you are using. NI recommends a  $0.565\text{ N}\cdot\text{m}$  ( $5\text{ lb}\cdot\text{in.}$ ) wrench for SMA connectors and an  $0.90\text{ N}\cdot\text{m}$  ( $8\text{ lb}\cdot\text{in.}$ ) wrench for 3.5 mm connectors.
- Lock all test equipment to the REF OUT signal on the back of the PXI Express chassis. Refer to the NI 5667 Timing Configurations topic in the NI RF Vector Signal Analyzers Help for more information about configuring clocking sources.

## Noise Source Setup

The recommended noise source is not programmable and instead should have ENR and Frequency values written on its label based on its last calibration. When the procedure runs, you will be prompted to fill in an ENR table. This table should be filled in so that it exactly matches the values on your noise source, and then saved using the dialog.

## PXIe-5698 Calibration Procedure

Calibrate the PXIe-5698 using Calibration Executive.

### Calibration Executive Procedure Features

Verify Only ✓	Verify & Adjust ⓧ	Manual Mode ⓧ	Optional Adjust ⓧ
---------------	-------------------	---------------	-------------------

## Approximate Test Time

Warmup	Characterization	Verify Only
30 minutes	22 minutes (+ warmup)	10 minutes (+ warmup + characterization)

## Test Equipment

The following table lists the test equipment required for calibrating PXIe-5698 modules.

**Table 312.** Test equipment for calibrating the PXIe-5698

Instrument	Recommended Model	Where Used	Requirements
Power Meter	Anritsu ML2438A	All	Display resolution: $\leq 0.01$ dB Settle per reading: 0.10% Instrumentation accuracy: $< \pm 0.5\%$ Reference power uncertainty: 1.2%/year Reference output VSWR: $< 1.04 : 1$
Power Sensors (x2)	Anritsu SC7413	All	Power range: -55 dBm to -20 dBm Frequency range: 10 MHz to 26.5 GHz Input VSWR: <ul style="list-style-type: none"> <li>• &lt;150 MHz: <math>&lt; 1.17 : 1</math></li> <li>• 150 MHz to &lt;2 GHz: <math>&lt; 1.08 : 1</math></li> <li>• 2 GHz to &lt;12.4 GHz: <math>&lt; 1.16 : 1</math></li> <li>• 12.4 GHz to &lt;18 GHz: <math>&lt; 1.21 : 1</math></li> <li>• 18 GHz to &lt;26.5 GHz: <math>&lt; 1.29 : 1</math></li> </ul> Linearity: <ul style="list-style-type: none"> <li>• &lt;18 GHz: <math>&lt; 1.8\%</math></li> <li>• 18 GHz to &lt;26.5 GHz: <math>&lt; 2.5\%</math></li> </ul>

Instrument	Recommended Model	Where Used	Requirements
RF source	Anritsu MG3694C Options 2B, 4, and 28B	All	<p>Frequency range: 10 MHz to 26.5 GHz</p> <p>Level power: -15 dBm</p> <p>Harmonics:</p> <ul style="list-style-type: none"> <li>• 10 MHz to <math>\leq 100</math> MHz: <math>&lt; -40</math> dBc</li> <li>• <math>&gt; 100</math> MHz to <math>\leq 2.2</math> GHz: <math>&lt; -50</math> dBc</li> <li>• <math>&gt; 2.2</math> GHz to 26.5 GHz: <math>&lt; -30</math> dBc</li> </ul> <p>Nonharmonic spurious:</p> <ul style="list-style-type: none"> <li>• 10 MHz to <math>\leq 2.2</math> GHz: <math>&lt; -60</math> dBc</li> <li>• <math>&gt; 2.2</math> GHz to <math>\leq 26.5</math> GHz: <math>\leq -60</math> dBc</li> </ul>
PXI Express Chassis	PXIe-1075 or PXIe-1085	All	—
PXI Express Controller	PXIe-8133 or PXIe-8135	All	—
Spectrum analyzer	PXIe-5668, 26.5 GHz variant with the 765 MHz instantaneous bandwidth	Gain	<p>Frequency range: 10 MHz to 26.5 GHz</p> <p>Reference level: -50 dBm to 0 dBm</p> <p>Amplitude accuracy: <math>\pm 1.5</math> dB</p>
5698 to 5668R semi-rigid cable, AMP OUT to RF IN	NI PN: 159289A-01	Verification	—
2.92 mm (m)-to-2.92 mm (m) cables (24 in.) (x3)	—	—	<p>Frequency range: 10 MHz to 26.5 GHz</p> <p>Insertion loss: <math>\leq 5</math> dB at 26.5 GHz</p> <p>Impedance: 50 <math>\Omega</math></p>
2.92 mm (m)-to-2.92 mm (m) adaptor	Anritsu K220B		<p>Frequency range: 10 MHz to 26.5 GHz</p> <p>Impedance: 50 <math>\Omega</math></p>



Instrument	Recommended Model	Where Used	Requirements
			VSWR: <ul style="list-style-type: none"> <li>10 MHz to <math>\leq 26.5</math> GHz: <math>&lt;1.12 : 1</math></li> </ul>
Attenuator	Anritsu 41KC-20	—	Frequency range: 10 MHz to 26.5 GHz Attenuation: 20 dB (nominal) Power rating: 2 W average Impedance: 50 $\Omega$ VSWR: <ul style="list-style-type: none"> <li>10 MHz to 12 GHz: <math>\leq 1.10 : 1</math></li> <li>12 GHz to 18 GHz: <math>\leq 1.15 : 1</math></li> <li>18 GHz to 26.5 GHz: <math>\leq 1.18 : 1</math></li> </ul>
Power splitter (two-resistor type)	Weinschel 1534		Frequency range: 10 MHz to 26.9 GHz Insertion loss: $\leq 10.5$ dB (6 dB, nominal) Power rating: 1 W Output VSWR: $\leq 1.35 : 1$ <div style="border: 1px solid black; padding: 5px; margin-top: 10px;">  <p><b>Note</b> Ensure that the equivalent splitter output SWR meets the above requirement between 10 MHz and 26.5 GHz.</p> </div>
Torque wrench	NI 781615-01	—	1 N · m (9 lb · in)

## Test Conditions

The following setup and environmental conditions are required to ensure the PXIe-5698 meets published specifications.

- Keep cabling as short as possible. Long cables and wires act as antennas, picking up extra noise that can affect measurements.
- Verify that all connections, including front panel connections and screws, are secure.
- Use an appropriate torque wrench or torque screwdriver and SMA driver bit to tighten all module RF connectors (SMA or 2.92 mm). NI recommends use of  $1 \text{ N} \cdot \text{m}$  ( $9 \text{ lb} \cdot \text{in}.$ ).
- Maintain an ambient temperature of  $23 \text{ }^\circ\text{C} \pm 5 \text{ }^\circ\text{C}$ .
- Keep the relative humidity between 10% and 90%, noncondensing.
- Ensure that the PXI Express chassis fan speed is set to HIGH, that the fan filters, if present, are clean, and that the empty slots contain filler panels. For more information about maintaining adequate air circulation in your PXI/PXI Express chassis, refer to the Maintain Forced-Air Cooling Note to Users document available at [ni.com/docs](http://ni.com/docs).
- Allow a warm-up time of at least 30 minutes after the chassis is powered on and NI-RFSA is loaded and recognizes the PXIe-5698. The warm-up time ensures that the PXIe-5698 and test instrumentation are at a stable operating temperature.
- In each verification procedure, insert a delay between configuring all devices and acquiring the measurement. Adjust this delay depending on the instruments used but make sure it is at least 1,000 ms for the first iteration and 100 ms for each other iteration.
- Lock all test equipment to the REF OUT signal on the back of the PXI Express chassis.

## Device Setup

1. Install the PXIe-5698 in the PXI chassis according to the instructions in the ***PXIe-5698 Getting Started*** documentation.



**Note** The PXIe-5698 must be installed in the chassis slot adjacent to and on the left side of the PXIe-5668R.

2. Configure the hardware using Measurement & Automation Explorer (MAX).
3. Launch the Calibration Executive procedure. Calibration Executive guides you through the required connections.

## Related concepts:

- [Launching a Calibration Procedure](#)

## PXIe-5840 Calibration Procedure

Calibrate the PXIe-5840 using Calibration Executive.

### Calibration Executive Procedure Features

Verify Only ✓	Verify & Adjust ⓧ	Manual Mode ⓧ	Optional Adjust ⓧ
---------------	-------------------	---------------	-------------------

### Approximate Test Time

Self-Calibration	Verify Only
25 minutes	30 minutes

### Test Equipment

The following table lists the test equipment required to calibrate PXIe-5840.

**Table 280.** Test equipment for calibrating the PXIe-5840

Instrument	Recommended Model	Where Used	Minimum Requirements
Frequency reference	Symmetricon 8040 Rubidium Frequency Standard	Verifications: <ul style="list-style-type: none"> <li>• Internal frequency reference</li> <li>• Spectral purity</li> </ul>	Frequency: 10 MHz Frequency accuracy: $\leq \pm 1E-9$ Output mode: sinusoid
Power sensor	Rohde & Schwarz NRP-Z91 with NRP-Z4 USB adapter	Test system characterization Verifications: <ul style="list-style-type: none"> <li>• Absolute amplitude accuracy</li> <li>• Output power level accuracy</li> </ul>	Range: -60 dBm to +20 dBm Frequency range: 10 MHz to 6 GHz Absolute

Instrument	Recommended Model	Where Used	Minimum Requirements
			uncertainty: 0.15 dB  Power linearity: <0.17 dB  VSWR: <1.22:1 up to 6 GHz
Spectrum analyzer or vector signal analyzer	PXIe-5665	Test system characterization Verifications: <ul style="list-style-type: none"> <li>• Spectral purity</li> <li>• Output power level accuracy</li> <li>• Output frequency response</li> </ul>	Frequency range: 10 MHz to 12 GHz  Instantaneous bandwidth: 50 MHz  Phase noise at 20 kHz offset: <-125 dBm/Hz
Power splitter (x2)	Aeroflex/Weinschel 1593	Test system characterization Verifications: <ul style="list-style-type: none"> <li>• Frequency response</li> <li>• Absolute amplitude accuracy</li> <li>• Output power level accuracy</li> </ul>	VSWR: $\leq 1.25:1$ up to 18 GHz  Amplitude tracking: <0.25 dB
6 dB attenuator (x4)	Anritsu 41KB-6 or Mini-Circuits	Test system characterization Verifications: <ul style="list-style-type: none"> <li>• Frequency response</li> <li>• Absolute amplitude accuracy</li> <li>• Output power level accuracy</li> </ul>	Frequency range: DC to 6 GHz  VSWR: $\leq 1.1:1$
50 $\Omega$ SMA terminator	—	Test system characterization Average noise density verification	Frequency range: DC to 6 GHz

Instrument	Recommended Model	Where Used	Minimum Requirements
			VSWR: $\leq 1.1:1$
SMA (m)-to-SMA (m) cable (x3)	—	All procedures	Frequency range: DC to 6 GHz  Impedance: 50 $\Omega$
SMA (m)-to-MMPX (m) cable (x2)	NI P/N 786000-12	All procedures	—
SMA (m)-to-N (f) adapter (x3)	33_SMA-N-50-1/1-_UE	Test system characterization	Frequency range: DC to 6 GHz  Impedance: 50 $\Omega$  Return loss: $\geq 23$ dB
SMA (f)-to-N (f) adapter	Huber+Suhner 31_N-SMA-50-1/1-_UE	Test system characterization	Frequency range: DC to 6 GHz  Impedance: 50 $\Omega$  Return loss: $\geq 23$ dB
3.5 mm (m)-to-3.5 mm (m) adapter (x2)	Huber+Suhner 32_PC35-50-0-2/199_NE	Test system characterization Verifications: <ul style="list-style-type: none"> <li>• Frequency response</li> <li>• Absolute amplitude accuracy</li> <li>• Output power level accuracy</li> </ul>	Frequency range: DC to 6 GHz  Impedance: 50 $\Omega$  Return loss: $\geq 30$ dB
3.5 mm (f)-to-3.5 mm (f) adapter	Huber+Suhner 31_PC35-50-0-1/199_UE	Test system characterization	Frequency range: DC to 6 GHz  Impedance: 50 $\Omega$

Instrument	Recommended Model	Where Used	Minimum Requirements
			Return loss: $\geq 30$ dB

## Test Conditions

The following setup and environmental conditions are required to ensure the PXIe-5840 meets published specifications.

- Ensure that the PXI chassis fan speed is set to HIGH, that the fan filters are clean, and that the empty slots contain filler panels. For more information about cooling, refer to the Maintain Forced-Air Cooling Note to Users document available at [ni.com/docs](http://ni.com/docs).
- Allow a warm-up time of at least 30 minutes after the chassis is powered on and NI-RFSA/G Instrument Design Libraries are loaded and recognize the PXIe-5840. The warm-up time ensures that the PXIe-5840 and test instrumentation are at a stable operating temperature.
- Maintain an ambient temperature of  $23\text{ }^{\circ}\text{C} \pm 5\text{ }^{\circ}\text{C}$ .
- Keep relative humidity between 10% and 90%, noncondensing.
- Keep cabling as short as possible. Long cables act as antennas, picking up extra noise that can affect measurements.
- Verify that all connections to the PXIe-5840, including front panel connections and screws, are secure.

## Device Setup

1. Install the PXIe-5840 in the PXI chassis according to the instructions in the PXIe-5840 Getting Started Guide, which is available at [ni.com/docs](http://ni.com/docs).
2. Configure the hardware using Measurement & Automation Explorer (MAX).
3. Perform a self-calibration before running the Verification Only procedure.
4. Launch the Calibration Executive procedure and complete the setup wizard.

## Self-Calibration

You can skip the self-calibration at the beginning of the procedure if both the

PXIe-5840 and the external transceiver meet the following conditions:

- The device temperature is within  $\pm 5$  °C of the last self-calibration temperature.
- The device has not been power-cycled since the last self-calibration.

Otherwise, Calibration Executive automatically performs self-calibration for both the PXIe-5840 and the external transceiver simultaneously. If either self-calibration is unsuccessful, Calibration Executive retires each self-calibration sequentially to avoid signal interactions between the devices. This can increase the test time for the automated calibration procedure.



**Note** If you are using the same device as the DUT and external transceiver, Calibration Executive will only perform the self-calibration on the DUT.

If the self-calibration of the PXIe-5840 fails, verify that the device is meeting the test conditions, including ambient temperature stability and chassis fan speed, and restart the procedure. If the self-calibration failure cannot be resolved, the device may need to be repaired.

## Fixture Characterization Considerations

Characterize each fixture at the beginning of the procedure. Calibration Executive does not support saving characterization data between separate procedure runs. For a characterization to maintain its validity during calibration, ensure that no portion of the fixture is disconnected or modified during the procedure run. Avoid re-torquing any part of the fixture.

The following figures indicate the portion of the fixtures that must remain intact during use.

Figure 1. Input Accuracy Fixture

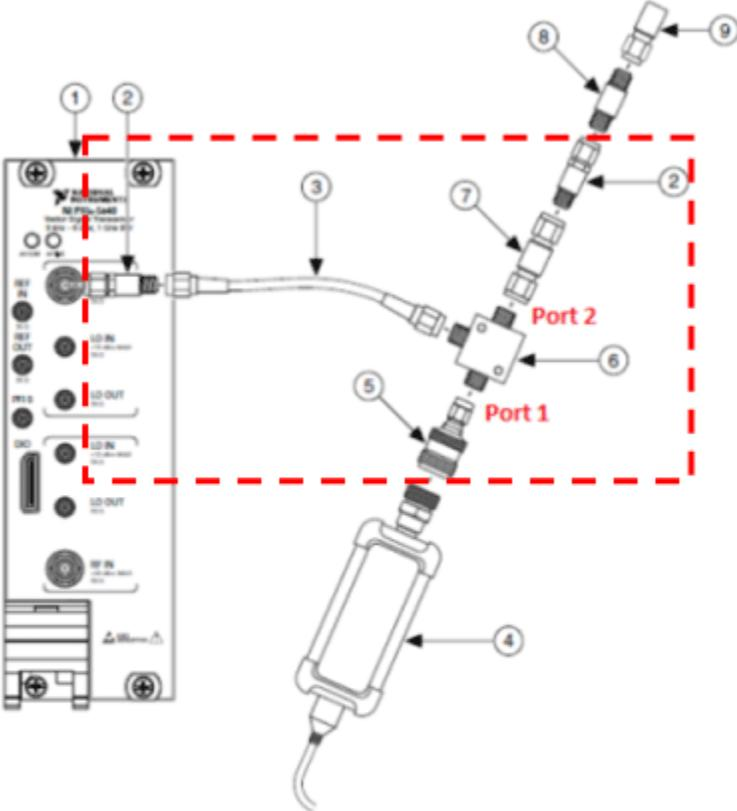

- 
- |                             |                                     |
|-----------------------------|-------------------------------------|
| 1. DUT (PXIe-5840)          | 6. Power Splitter                   |
| 2. 6 dB Attenuator          | 7. 3.5 mm (m)-to-3.5 mm (m) Adapter |
| 3. SMA (m)-to-SMA (m) Cable | 8. 3.5 mm (f)-to-3.5 mm (f) Adapter |
| 4. Power Sensor             | 9. 50 $\Omega$ Terminator           |
| 5. SMA (m)-to-N (f) Adapter |                                     |
-



Figure 1. Output Accuracy Fixture

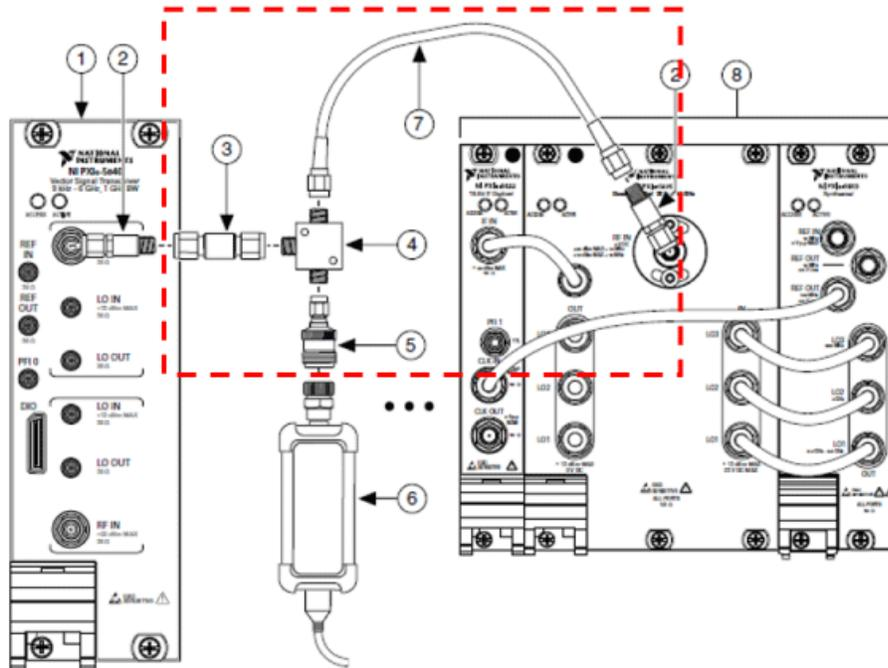

- |                               |                             |
|-------------------------------|-----------------------------|
| 1. DUT (PXIe-5840)            | 5. SMA (m)-to-N (f) Adapter |
| 2. 6 dB Attenuator            | 6. Power Sensor             |
| 3. SMA (m)-to-SMA (m) Adapter | 7. SMA (m)-to-SMA (m) Cable |
| 4. Power Splitter             | 8. Spectrum Analyzer        |

## RF Signal Generator

The PXIe-5840 calibration procedure is designed to use the RF Out of the DUT to perform the splitter characterization and the input accuracy tests. If RF Out is not functional, you can use a separate PXIe-5840 module instead to complete the verification of these tests. Prior to starting the procedure, the operator can select a separate PXIe-5840 module in the setup wizard, on the DUT Selection screen.

## Test Limit Equations

Table 281. PXIe-5840 Test Limit Equations

Equation Type	Equations
Internal Frequency Reference Accuracy	<p>As-Found Test Limit = <math>\pm[(\text{Initial adjustment accuracy} + \text{Temperature stability}) + (\text{Aging} \times 1 \text{ year})]</math></p> <p>As-Left Test Limits = <math>\pm(\text{Initial adjustment}</math></p>

Equation Type	Equations
	accuracy + Temperature stability)
2-Year Calibration Interval	<p>When you run the PXIe-5840 verification procedure using a 2-year interval, the Internal Frequency Reference Accuracy limit uses two years for aging instead of one year, and 0.2 dB is added to the as-found test limits for the following tests:</p> <ul style="list-style-type: none"> <li>• RF Input Absolute Amplitude Accuracy</li> <li>• RF Input Frequency Response</li> <li>• RF Output Power Level Accuracy</li> <li>• RF Output Frequency Response</li> </ul>

### Related concepts:

- [Launching a Calibration Procedure](#)

## PXIe-5841 Calibration Procedure

Calibrate the PXIe-5841 using Calibration Executive. This procedure supports the PXIe-5841, the PXIe-5841 Analyzer Only, and PXIe-5841 Generator Only procedures.

### Calibration Executive Procedure Features

Verify Only ✓	Adjust Only ✓	Verify & Adjust ✓	Manual Mode ✗	Optional Adjust ✗
---------------	---------------	-------------------	---------------	-------------------

## Approximate Test Time

**Table 282.** Approximate Test Time for the PXIe-5841

Run Options	Warm-up 30 minutes <sup>1</sup>	Self-Calibration 25-75 minutes <sup>2</sup>	Characterization 15 minutes	As-found Verify Steps 60 minutes	Adjust Steps 250 minutes	As-left Verify Steps 60 minutes	Total
Verify Only	X	X	X	X	—	—	130 to 180 minutes
Adjust Only	X	X <sup>3</sup>	X	—	X	—	320 minutes
Verify & Adjust	X	X	X	X	X	X	440 to 490 minutes

**Table 283.** Approximate Test Time for the PXIe-5841 Analyzer Only

Run Options	Warm-up 30 minutes <sup>1</sup>	Self-Calibration 25-75 minutes <sup>2</sup>	Characterization 15 minutes	As-found Verify Steps 45 minutes	Adjust Steps 250 minutes	As-left Verify Steps 45 minutes	Total
Verify Only	X	X	X	X	—	—	115 to 165 minutes
Adjust Only	X	X <sup>3</sup>	X	—	X	—	320 minutes
Verify & Adjust	X	X	X	X	X	X	410 to 460 minutes

**Table 284.** Approximate Test Time for the PXIe-5841 Generator Only

Run Options	Warm-up 30 minutes <sup>1</sup>	Self-Calibration 25-75 minutes <sup>2</sup>	Characterization 15 minutes	As-found Verify Steps 15 minutes	Adjust Steps 250 minutes	As-left Verify Steps 15 minutes	Total
Verify Only	X	X	X	X	—	—	85 to 135 minutes
Adjust Only	X	X <sup>3</sup>	X	—	X	—	320 minutes
Verify & Adjust	X	X	X	X	X	X	350 to 400 minutes



## Note

- <sup>1</sup> Warm-up time is based on when the DUT was powered on. Warm-up can be skipped if not applicable for a specific calibration run.
- <sup>2</sup> Self-calibration can be skipped if the PXIe-5841 devices have not been power-cycled and if the internal temperature is maintained to  $\pm 5$  °C of the last self-calibration.
- <sup>3</sup> Self-calibration for Adjust Only is 25 minutes because only the external transceiver needs to be self-calibrated.

## Test Equipment

The following table lists the test equipment required to calibrate PXIe-5841.

**Table 290.** Test equipment for calibrating the PXIe-5841

Instrument	Recommended Model	Where Used	Minimum Requirements
Frequency reference	Symmetricon 8040 Rubidium Frequency Standard	Verifications:	Frequency: 10 MHz

Instrument	Recommended Model	Where Used	Minimum Requirements
		<ul style="list-style-type: none"> <li>Internal frequency reference</li> <li>Spectral purity</li> </ul>	Frequency accuracy: $\leq \pm 1E-9$  Output mode: sinusoid
Power sensor	Rohde & Schwarz NRP-18A	Test system characterization Verifications: <ul style="list-style-type: none"> <li>Input absolute amplitude accuracy</li> <li>Frequency response</li> <li>Output power level accuracy</li> </ul>	Range: -60 dBm to +20 dBm  Frequency range: 10 MHz to 6.5 GHz  Absolute uncertainty: <0.097 dB  Power linearity: <0.097 dB  VSWR: <1.20:1 up to 6.5 GHz
Vector signal analyzer	PXIe-5668R	Test system characterization RF output IMD3 functional performance test Adjustments: <ul style="list-style-type: none"> <li>RF internal frequency reference</li> <li>LO gain</li> </ul>	Frequency range: 10 MHz to 6.5 GHz  Instantaneous bandwidth: 50 MHz  Phase noise at 20 kHz offset: <-125 dBc/Hz
RF Signal Generator #1	PXIe-5654 with PXIe-5696	RF input IMD3 functional performance test Adjustment: <ul style="list-style-type: none"> <li>LO gain</li> </ul>	Output amplitude range: +5 dBm to -55 dBm  Frequency range:

Instrument	Recommended Model	Where Used	Minimum Requirements
			70 MHz to 6.5 GHz
RF Signal Generator #2	PXIe-5654 with PXIe-5696*  or  Anritsu MG3692C Options 2A, 4 and 28A   <b>Note</b> Do not use Option 15.	RF input IMD3 functional performance test	Output amplitude range: +5 dBm to -55 dBm  Frequency range: 70 MHz to 6.5 GHz
Power splitter (x3)	Aeroflex/Weinschel 1593	Used in the following fixtures for test system characterization: <ul style="list-style-type: none"> <li>• RF input power splitter assembly (x1)</li> <li>• RF output power splitter assembly (x1)</li> <li>• LO splitter assembly (x1)</li> </ul> Verifications: <ul style="list-style-type: none"> <li>• Frequency response</li> <li>• Input absolute amplitude accuracy</li> <li>• Output power level accuracy</li> </ul> Adjustments: <ul style="list-style-type: none"> <li>• Input absolute amplitude accuracy</li> <li>• Output power level accuracy</li> <li>• LO gain</li> </ul>	VSWR: $\leq 1.25:1$ up to 18 GHz  Amplitude tracking: $< 0.25$ dB

Instrument	Recommended Model	Where Used	Minimum Requirements
Power Combiner	Mini Circuits ZFRSC-123-S+	Input/Output IMD3 functional performance test	Impedance: 50 $\Omega$ Frequency: DC to 12 GHz Isolation: 19.5 dB
6 dB attenuator (x3)	Anritsu 41KB-6 or Mini-Circuits BW-S6-2W263+	Used in the following fixtures for test system characterization: <ul style="list-style-type: none"> <li>• RF input power splitter assembly (x1)</li> <li>• LO splitter assembly (x1)</li> </ul> Used as a part of the characterization (x1): <ul style="list-style-type: none"> <li>• RF output power splitter assembly</li> <li>• LO MMPX cable loss assembly</li> </ul> Adjustments: <ul style="list-style-type: none"> <li>• Input absolute amplitude accuracy</li> <li>• Output power level accuracy</li> </ul>	Frequency range: DC to 6.5 GHz VSWR: $\leq 1.1:1$
12 dB attenuator	Mini Circuits BW-S12W2+	Used in the following fixtures for test system characterization: <ul style="list-style-type: none"> <li>• RF output power splitter assembly</li> </ul> Verification: <ul style="list-style-type: none"> <li>• Output power level accuracy</li> </ul> Adjustment: <ul style="list-style-type: none"> <li>• LO gain</li> </ul>	VSWR: $\leq 1.25:1$ Frequency range: DC to 6.5 GHz

Instrument	Recommended Model	Where Used	Minimum Requirements
20 dB attenuator	Anritsu 41KC-20	Used in the following fixture: <ul style="list-style-type: none"> <li>LO MMPX cable loss assembly</li> </ul> Adjustment: <ul style="list-style-type: none"> <li>LO gain</li> </ul>	VSWR: $\leq 1.1:1$ Frequency range: DC to 6.5 GHz
50 $\Omega$ SMA terminator	—	Test system characterization	Frequency range: DC to 6.5 GHz VSWR: $\leq 1.1:1$
SMA (m)-to-SMA (m) cable (x7)	—	All procedures	Frequency range: DC to 6.5 GHz Impedance: 50 $\Omega$
SMA (m)-to-MMPX (m) cable (x3)	NI P/N 786000-12	Used in the following fixtures for test system characterization: <ul style="list-style-type: none"> <li>LO MMPX cable loss assembly (x1)</li> <li>LO splitter assembly (x1)</li> </ul> Used in the following steps (x1): Verifications: <ul style="list-style-type: none"> <li>RF input spectral purity</li> <li>RF output spectral purity</li> </ul> Adjustment: <ul style="list-style-type: none"> <li>Adjusting LO gain (RF IN and RF OUT)</li> </ul>	Frequency range: DC to 6.5 GHz Impedance: 50 $\Omega$
MMPX (m)-to-BNC (m) cable (x3)	NI P/N 763771-01	All procedures	—



Instrument	Recommended Model	Where Used	Minimum Requirements
MMCX (f)-to-SMA (f) adapter	—	Test system characterization	—
SMA (f)-to-N (f) adapter	Huber+Suhner 31_N-SMA-50-1/1-_UE	Test system characterization	Frequency range: DC to 6.5 GHz  Impedance: 50 Ω  Return loss: ≥23 dB
SMA (m)-to-N (f) adapter (x4)	33_SMA-N-50-1/1-_UE	Used in the following fixtures for test system characterization: <ul style="list-style-type: none"> <li>• RF input power splitter assembly (x1)</li> <li>• RF output power splitter assembly (x1)</li> <li>• LO splitter assembly (x1)</li> </ul> Used in test system characterization tests (x1)	Frequency range: DC to 6.5 GHz  Impedance: 50 Ω  Return loss: ≥23 dB
3.5 mm (m)-to-3.5 mm (m) adapter (x2)	Huber+Suhner 32_PC35-50-0-2/199_NE	Used in the following fixtures for test system characterization: <ul style="list-style-type: none"> <li>• RF input power splitter assembly (x1)</li> <li>• RF output power splitter assembly (x1)</li> </ul> Verifications: <ul style="list-style-type: none"> <li>• Frequency response</li> <li>• Absolute amplitude accuracy</li> <li>• Output power level accuracy</li> </ul> Adjustments: <ul style="list-style-type: none"> <li>• Input absolute amplitude accuracy</li> </ul>	Frequency range: DC to 6.5 GHz  Impedance: 50 Ω  Return loss: ≥30 dB

Instrument	Recommended Model	Where Used	Minimum Requirements
		<ul style="list-style-type: none"> <li>Output power level accuracy</li> </ul>	
3.5 mm (f)-to-3.5 mm (f) adapter	Huber+Suhner 31_PC35-50-0-1/ 199_UE	Test system characterization	Frequency range: DC to 6.5 GHz  Impedance: 50 $\Omega$  Return loss: $\geq 30$ dB
External transceiver	PXIe-5841	Test system characterization Adjustments/Verifications: <ul style="list-style-type: none"> <li>Input absolute amplitude accuracy</li> <li>Frequency response</li> <li>Power level accuracy</li> </ul>	Frequency range: 10 MHz to 6.5 GHz  RF input reference range: -40 dB to 20 dB  RF output power range: -20 dBm to 4 dBm  Digital gain linearity: <0.054 dB
Chassis	PXIe-1095	All procedures	—



**Note** \*If you are using a PXIe-5654 with a PXIe-5696 as RF Signal Generator #2, you may need to use an additional chassis with an MXI controller.

## Test Conditions

The following setup and environmental conditions are required to ensure the PXIe-5841 meets published specifications.

- Ensure that the PXI chassis fan speed is set to HIGH, that the fan filters are clean, and that the empty slots contain filler panels. For more information about cooling,

refer to the Maintain Forced-Air Cooling Note to Users document available at [ni.com/docs](http://ni.com/docs).

- Allow a warm-up time of at least 30 minutes after the chassis is powered on and NI-RFSA/G Instrument Design Libraries are loaded and recognize the PXIe-5841. The warm-up time ensures that the PXIe-5841 and test instrumentation are at a stable operating temperature.
- Maintain an ambient temperature of  $23\text{ }^{\circ}\text{C} \pm 5\text{ }^{\circ}\text{C}$ .
- Keep relative humidity between 10% and 90%, noncondensing.
- Keep cabling as short as possible. Long cables act as antennas, picking up extra noise that can affect measurements.
- Verify that all connections to the PXIe-5841, including front panel connections and screws, are secure.

## Device Setup

1. Install the PXIe-5841 in the PXI chassis according to the instructions in the PXIe-5841 Getting Started Guide, which is available at [ni.com/docs](http://ni.com/docs).
2. Configure the hardware using Measurement & Automation Explorer (MAX).
3. Perform a self-calibration before running the Verification Only procedure.
4. Launch the Calibration Executive procedure and complete the setup wizard.
  - a. On the DUT Selection page, designate the external transceiver in the **NI 5841 External Transceiver** drop-down list.
  - b. Select the **DUT** checkbox for the device you want to calibrate and de-select the **DUT** checkbox for the device you designated as the external transceiver.
5. Connect the reference frequency standard to the DUT, standard PXIe-5841 devices, and other standards.

## Self-Calibration

You can skip the self-calibration at the beginning of the procedure if both the PXIe-5841 and the external transceiver meet the following conditions:

- The device temperature is within  $\pm 5\text{ }^{\circ}\text{C}$  of the last self-calibration temperature.
- The device has not been power cycled since the last self-calibration.

Otherwise, Calibration Executive automatically performs self-calibration for both the PXIe-5841 and the external transceiver simultaneously. If either self-calibration is unsuccessful, Calibration Executive retries each self-calibration sequentially to avoid

signal interactions between the devices. This can increase the test time for the automated calibration procedure.

If the self-calibration of the PXIe-5841 fails, verify that the device is meeting the test conditions, including ambient temperature stability and chassis fan speed, and restart the procedure. Additionally, NI recommends performing an Adjust Only run to resolve self-calibration errors. If the self-calibration failure cannot be resolved, the device may need to be repaired.

For Adjust Only run mode, Calibration Executive performs self-calibration of the external transceiver only at the beginning of the procedure.

### **External Transceiver IMD3 Failure Consideration**

Calibration Executive executes the IMD3 characterization of the external transceiver at the beginning of the calibration procedure. These characterization results are not shown on the calibration report. The external transceiver must pass the IMD3 characterization before you can use it for calibration. If the external transceiver device fails the IMD3 characterization repeatedly, repair the device or replace it with another module.

### **Fixture Characterization Considerations**

Characterize each fixture at the beginning of the procedure. Calibration Executive does not support saving characterization data between separate procedure runs. For a characterization to maintain its validity during calibration, ensure that no portion of the fixture is disconnected or modified during the procedure run. Avoid re-torquing any part of the fixture.

The following figures indicate the portion of the fixtures that must remain intact during use.

Figure 1. RF Input Power Splitter Assembly

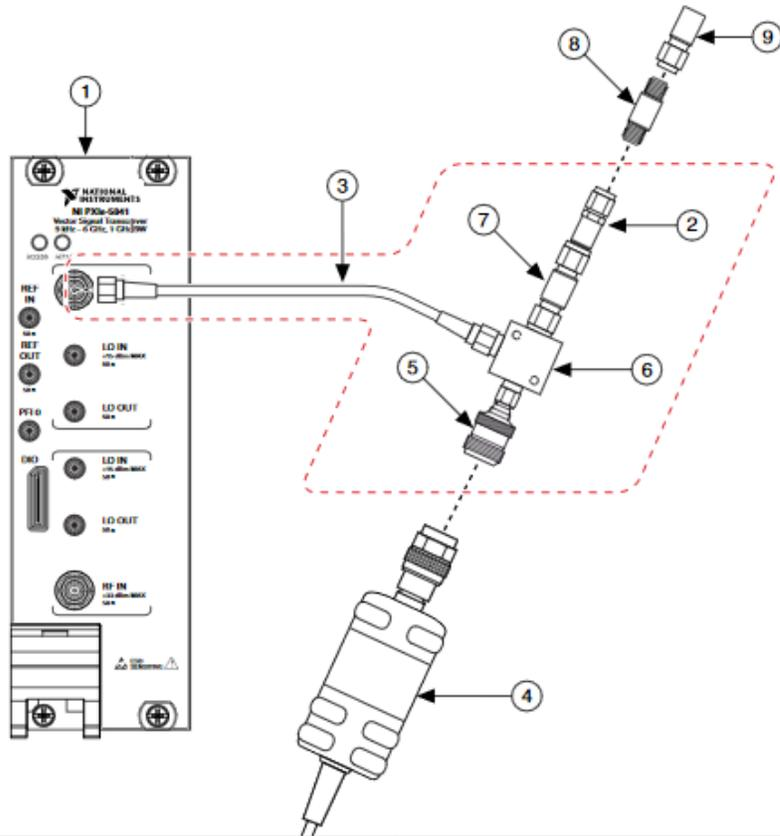

- |                             |                                     |
|-----------------------------|-------------------------------------|
| 1. External Transceiver     | 6. Power Splitter                   |
| 2. 6 dB Attenuator          | 7. 3.5 mm (m)-to-3.5 mm (m) Adapter |
| 3. SMA (m)-to-SMA (m) Cable | 8. 3.5 mm (f)-to-3.5 mm (f) Adapter |
| 4. Power Sensor             | 9. 50 $\Omega$ Terminator           |
| 5. SMA (m)-to-N (f) Adapter |                                     |

Figure 1. RF Output Power Splitter Assembly

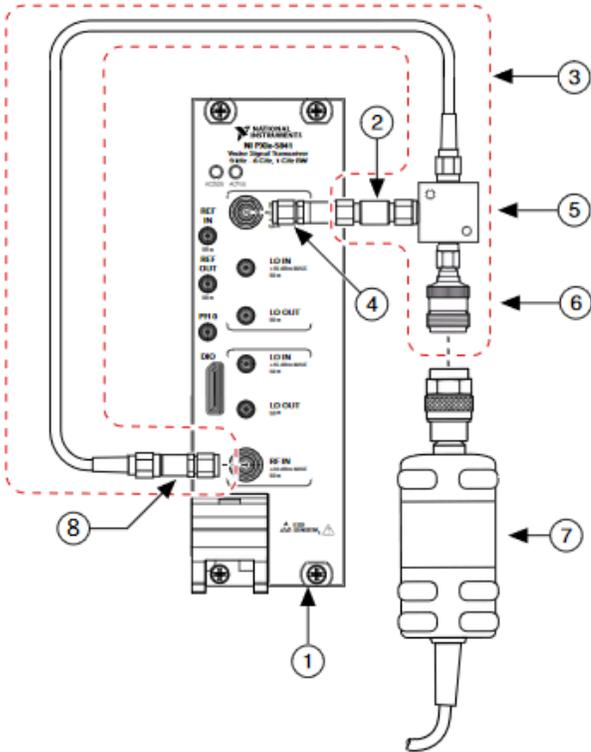

- 1. External Transceiver
- 2. SMA (m)-to-SMA (m) Adapter
- 3. SMA (m)-to-SMA (m) Cable
- 4. 6 dB Attenuator
- 5. Power Splitter
- 6. SMA (m)-to-N (f) Adapter
- 7. Power Sensor
- 8. 12 dB Attenuator

Figure 1. LO Splitter Assembly

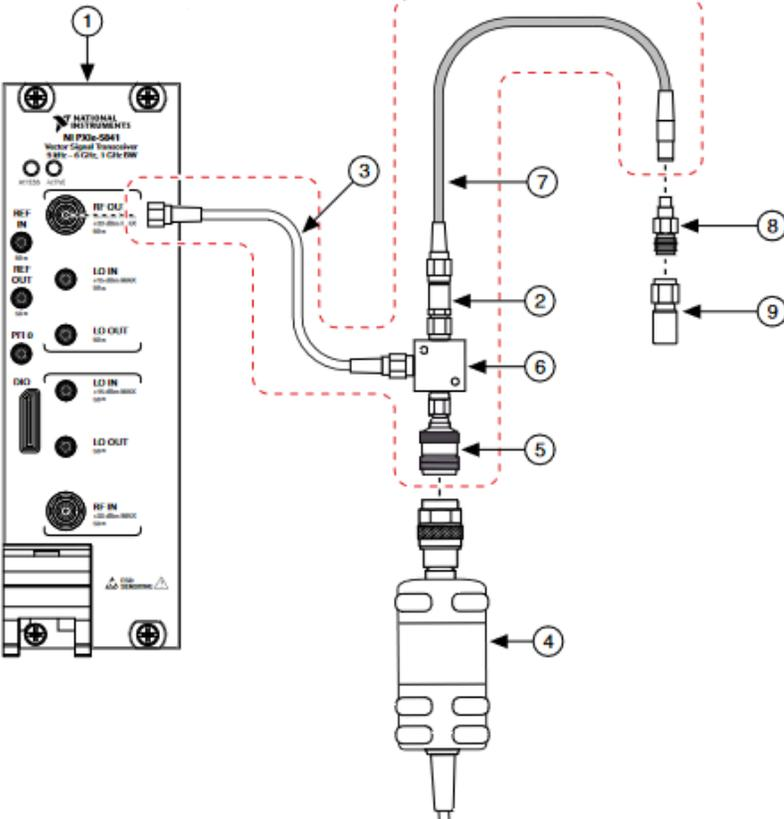

- 1. External Transceiver
- 2. 6 dB Attenuator
- 3. SMA (m)-to-SMA (m) Cable
- 4. Power Sensor
- 5. SMA (m)-to-N (f) Adapter
- 6. Power Splitter
- 7. SMA (m)-to-MMPX (m) Cable
- 8. MMPX (f)-to-SMA (f) Adapter
- 9. 50 Ω Terminator

Figure 1. LO MMPX Cable Loss Assembly

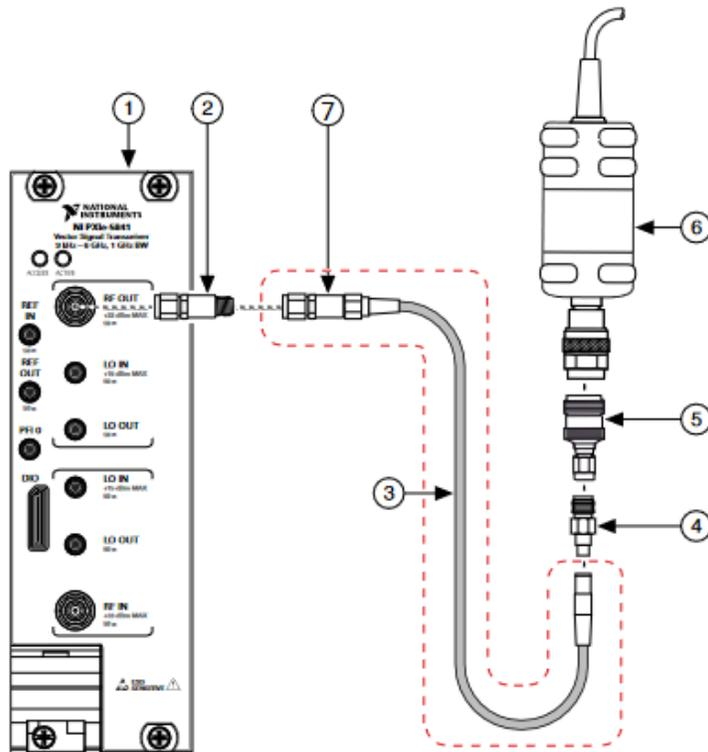

- |                              |                                |
|------------------------------|--------------------------------|
| 1. External Transceiver      | 4. MMPX (f)-to-SMA (f) Adapter |
| 2. 6 dB Attenuator           | 5. SMA (m)-to-N (f) Adapter    |
| 3. SMA (m)-to-MMPX (m) Cable | 6. Power Sensor                |
|                              | 7. 20 dB Attenuator            |

## Adjustment Considerations

Perform all adjustment steps, including the Adjust Self Calibrate step, without significant idle time between connection changes.

If you encounter an error during an adjustment step, re-run Adjust Only to resolve the problem. If the adjustment step repeatedly causes an error, repair the PXIe-5841 or replace it with another module.

## Test Limit Equations

The following test limits are derived from the published specifications.



Table 286. PXIe-5841 Test Limit Equations

Equation Type	Equation
Internal Frequency Reference Accuracy	<p>As-found Test Limit = <math>\pm[(\text{Initial adjustment accuracy} + \text{Temperature stability}) + (\text{Aging} \times 1 \text{ year})]</math></p> <p>As-left Test Limits = <math>\pm(\text{Initial adjustment accuracy} + \text{Temperature stability})</math></p>
2-Year Calibration Interval	<p>When you run the PXIe-5841 verification procedure using a 2-year interval, the Internal Frequency Reference Accuracy limit uses two years for aging instead of one year, and 0.2 dB is added to the as-found test limits for the following tests:</p> <ul style="list-style-type: none"> <li>• RF Input Absolute Amplitude Accuracy</li> <li>• RF Input Frequency Response</li> <li>• RF Output Power Level Accuracy</li> <li>• RF Output Frequency Response</li> </ul>

**Related concepts:**

- [Launching a Calibration Procedure](#)

## PXIe-5842 Calibration Procedure

Calibrate the PXIe-5842 using Calibration Executive.

The PXIe-5842 composite device consists of the PXIe-5655 and PXIe-5842 modules. Therefore, the PXIe-5655 that is associated with PXIe-5842 under test will be verified and adjusted as a part of this procedure along with the PXIe-5842 module.

### Calibration Executive Procedure Features

Verify Only ✓	Adjust Only ✓	Verify & Adjust ✓	Manual Mode ✗	Optional Adjust ✓
---------------	---------------	-------------------	---------------	-------------------

## Approximate Test Time



**Note** Test times are listed as Verify & Adjust / Verify Only and include calibration of both the PXIe-5842 and PXIe-5655. Test times do not include 30 minutes of warm-up time.

**Table 287.** Test Times for Analysis Only of the PXIe-5842 and PXIe-5655

Bandwidth	Frequency Range			
	26.5 GHz	18 GHz	12 GHz	8 GHz
2 GHz	7 hrs 50 mins / 2 hrs 50 mins	6 hrs 55 mins / 2 hrs 10 mins	6 hrs 15 mins / 1 hr 35 mins	5 hrs 45 mins / 1 hr 15 mins
1 GHz	7 hrs 15 mins / 2 hrs 40 mins	6 hrs 25 mins / 2 hrs	5 hrs 50 mins / 1 hr 30 mins	5 hrs 20 mins / 1 hr 10 mins
500 MHz	6 hrs 55 mins / 2 hrs 30 mins	6 hrs 5 mins / 1 hr 55 mins	5 hrs 30 mins / 1 hr 25 mins	5 hrs 5 mins / 1 hr 5 mins

**Table 288.** Test Times for Generation Only of the PXIe-5842 and PXIe-5655

Bandwidth	Frequency Range			
	26.5 GHz	18 GHz	12 GHz	8 GHz
2 GHz	7 hrs 5 mins / 2 hrs 30 mins	6 hrs 15 mins / 1 hr 50 mins	5 hrs 35 mins / 1 hr 20 mins	5 hrs 5 mins / 1 hr
1 GHz	6 hrs 35 mins / 2 hrs 20 mins	5 hrs 45 mins / 1 hr 45 min	5 hrs 10 mins / 1 hr 15 mins	4 hrs 45 mins / 1 hr
500 MHz	6 hrs 15 mins / 2 hrs 10 mins	5 hrs 30 mins / 1 hr 40 mins	4 hrs 55 mins / 1 hr 15 mins	4 hrs 30 mins / 55 mins

**Table 289.** Test Times for Analysis and Generation of the PXIe-5842 and PXIe-5655

Bandwidth	Frequency Range			
	26.5 GHz	18 GHz	12 GHz	8 GHz
2 GHz	11 hrs 35 mins / 4 hrs 25 mins	9 hrs 50 mins / 3 hrs 25 mins	8 hrs 30 mins / 2 hrs 40 mins	7 hrs 35 mins / 2 hrs 10 mins
1 GHz	10 hrs 50 mins / 4 hrs 5 mins	9 hrs 10 mins / 3 hrs 10 min	7 hrs 55 mins / 2 hrs 30 mins	7 hrs 5 mins / 2 hrs

	Frequency Range			
Bandwidth	26.5 GHz	18 GHz	12 GHz	8 GHz
500 MHz	10 hrs 15 mins / 3 hrs 55 mins	8 hrs 40 mins / 3 hrs	7 hrs 30 mins / 2 hr 20 mins	6 hrs 40 mins / 1 hr 55 mins

## Test Equipment

The following table lists the test equipment required to calibrate PXIe-5842.

**Table 290.** Test equipment for calibrating the PXIe-5841

Instrument	Recommended Model	Where Used	Minimum Requirements
Chassis	PXIe-1095, NI part number 785971-01	All	Timing sync option
Controller	PXIe-8881, NI part number 786636-01	All	16GB RAM/500GB SSD
Phase noise and Spectrum analyzer	Rohde & Schwarz FSWP26	<ul style="list-style-type: none"> <li>RF Input third-order intermodulation verification</li> <li>RF Output average noise density verification</li> <li>RF Output harmonic spurs verification</li> <li>RF Output third-order intermodulation verification</li> </ul>	See table below for options needed.
Power sensor #1	Rohde & Schwarz NRP33S	<ul style="list-style-type: none"> <li>Receiver fixture characterization</li> <li>Cable loss characterization</li> <li>RF Input absolute amplitude accuracy verification</li> <li>RF Input power linearity</li> </ul>	—

Instrument	Recommended Model	Where Used	Minimum Requirements
		accuracy verification <ul style="list-style-type: none"> <li>• Input frequency response verification</li> </ul>	
Power sensor #2	Rohde & Schwarz NRP33S	<ul style="list-style-type: none"> <li>• Receiver fixture characterization</li> <li>• Cable loss characterization</li> <li>• RF Output absolute amplitude verification</li> <li>• RF Output frequency response verification</li> <li>• Reference clock gain adjustment</li> <li>• RF transmission LO Output adjustment</li> <li>• RF receiver LO Output adjustment</li> </ul>	—
Signal generator (2x)	Rohde & Schwarz SMA100B 31.8 GHz See table below for options needed.	<ul style="list-style-type: none"> <li>• Receiver fixture characterization</li> <li>• Cable loss characterization</li> <li>• RF Input third-order intermodulation verification</li> <li>• RF Input absolute amplitude accuracy verification</li> <li>• RF Input power linearity accuracy verification</li> <li>• RF Input frequency response verification</li> </ul>	—
10 MHz Rb Reference standard	Microchip 8040	All	Reference clock routing

Instrument	Recommended Model	Where Used	Minimum Requirements
GPIB to USB Adapter (x3)	NI part number 783368-01	All	—
SMA (m) to BNC (m) cable	Fairview Microwave FMC0208315-36	All	<ul style="list-style-type: none"> <li>• Length: <math>\leq 1</math> meter or 36 inches</li> <li>• Reference clock routing</li> </ul>
BNC (m) to BNC (m) cable (3x)	Fairview Microwave FMC0808058-36	All	<ul style="list-style-type: none"> <li>• Length: <math>\leq 1</math> meter or 36 inches</li> <li>• Reference clock routing</li> </ul>
3.5 mm (m) to (m) cable (5x)	Maury Microwave SP-35MM-36-LP	<ul style="list-style-type: none"> <li>• Receiver fixture characterization</li> <li>• Cable loss characterization</li> <li>• RF Input third-order intermodulation verification</li> <li>• RF Input absolute amplitude accuracy verification</li> <li>• RF Input power linearity accuracy verification</li> <li>• RF Input frequency response verification</li> <li>• RF Output average noise density verification</li> <li>• RF Output harmonic spurs verification</li> <li>• RF Output third-order intermodulation verification</li> </ul>	Length: $\leq 1$ meter or 36 inches

Instrument	Recommended Model	Where Used	Minimum Requirements
3.5 mm power splitter (two-resistor type)	Keysight 11667B	<ul style="list-style-type: none"> <li>Receiver fixture characterization</li> <li>RF Input absolute amplitude accuracy verification</li> <li>RF Input power linearity accuracy verification</li> <li>RF Input frequency response verification</li> </ul>	VSWR: $\leq 1.22$
LF Power combiner	Mini Circuits ZFRSC-123-S+	RF Input third-order intermodulation verification	Frequency: DC to 12 GHz
HF 2.92 mm Power combiner	Mini Circuits ZC2PD-K0144+	RF Input third-order intermodulation verification	Frequency: 1 GHz to 26 GHz
45-degree SMA (m) to SMA (f) adapter	CentricRF C3243	<ul style="list-style-type: none"> <li>Receiver fixture characterization</li> <li>RF Input absolute amplitude accuracy verification</li> <li>RF Input power linearity accuracy verification</li> <li>RF Input frequency response verification</li> </ul>	VSWR: $\leq 1.12$
3.5 mm (f) to 3.5 mm (f) adapter (2x)	Maury Microwave CC-A-35-FF	<ul style="list-style-type: none"> <li>Receiver fixture characterization</li> <li>Cable loss characterization</li> <li>RF Output average noise density verification</li> <li>RF Output harmonic spurs verification</li> <li>RF Output third-order intermodulation verification</li> </ul>	VSWR: $\leq 1.12$

Instrument	Recommended Model	Where Used	Minimum Requirements
3.5 mm (m) to 3.5 mm (m) adapter	Maury Microwave CC-A-35-MM	<ul style="list-style-type: none"> <li>Receiver fixture characterization</li> <li>RF Input absolute amplitude accuracy verification</li> </ul>	VSWR: $\leq 1.12$
3.5 mm (m) 50 $\Omega$ terminator	Pasternack PE6TR1109	RF Input average noise density verification	VSWR: $\leq 1.15$
Laboratory Mini Scissor Lift Jack	—	Support power sensors	—

**Table 291.** Options for the Rohde & Schwarz FSWP26

Option	Description	Part Number
FSWP26	Phase noise analyzer and VCO tester 1 MHz to 26.5 GHz optionally with cross correlation and spectrum analyzer	1322.8003.26
FSWP-B1	Signal and spectrum analyzer 10 Hz to 26 GHz for Rohde & Schwarz FSWP26 (hardware option, retrofittable in factory)	1322.9997.26
FSWP-B4	High stability OCXO with low phase noise (hardware option)	1325.3890.02
FSWP-B24	RF Preamplifier, 20 dB 100 kHz to 26 GHz for Rohde & Schwarz FSWP26 option Rohde & Schwarz FSWP-B1 required (hardware option)	1325.3725.26
FSWP-B61	Cross correlation for phase noise analyzer Rohde & Schwarz FSWP26 from 1 MHz to 26 GHz (hardware option)	1322.9800.26

Table 292. Options for the SMA-100B

Option	Description	Part Number
SMAB-B131	Frequency range: 8 kHz to 31.8 GHz, not installable post factory (hardware option)	1420.8888.02
SMAB-B35	High output power 31.8/40 GHz, frequency option (Rohde & Schwarz SMAB-B131/B140/B140N) and 3HU option (Rohde & Schwarz SMAB-B93) required, not installable post factory (hardware option)	1420.7500.02
SMAB-K36	Ultra high output power 31.8/40 GHz, frequency option (Rohde & Schwarz SMAB-B131/B140(N)) and high-power option (Rohde & Schwarz SMAB-B35) required (software license)	1420.9178.02
SMAB-B86	Remote control GPIB/USB, retrofittable in Rohde & Schwarz service w/ UCS (hardware Option)	1420.6562.02
SMA100B	Signal Generator Base Unit, frequency option (Rohde & Schwarz SMAB-B103/B106/B112/B120/B131/B140/B140N/B150/B150N/B167/B167N) and height unit option (Rohde & Schwarz SMAB-B92/B93) required	1419.8888.02

## Test Conditions

The following setup and environmental conditions are required to ensure the PXIe-5842 meets published specifications.

- Maintain an ambient temperature of 22.5 °C  $\pm$ 2.5 °C.
- During adjustment, the internal device temperature must maintain  $\pm$ 2 °C stability



for the duration of the adjustment.

- Keep relative humidity between 10% and 90%, noncondensing.
- Allow a warm-up time of at least 30 minutes after powering on the chassis and NI-RFSA Instrument Design Libraries are loaded and recognize the PXIe-5842. The warm-up time ensures that the PXIe-5842 and test instrumentation are at a stable operating temperature.
- Allow proper warm up time for all instrumentation that you will use for verification and adjustment steps. See the respective specifications documents for the instrumentation for more details.
- Use a torque wrench appropriate for the type of RF connector that you are using. NI recommends a 0.565 N · m (5 lb · in.) wrench for SMA connectors and an 0.90 N · m (8 lb · in.) wrench for 2.92 mm connectors.
- Ensure that the PXI/PXI Express chassis fan speed is set to AUTO, that the fan filters are clean, and that the empty slots contain filler panels. For more information about cooling, refer to the ***Maintain Forced-Air Cooling Note to Users*** document available at [ni.com/docs](http://ni.com/docs).

## Device Setup

1. Install the PXIe-5842 along with the PXIe-5655 LO in the PXI Express chassis.
2. Verify that all connections, including front panel connections and screws, are secure.
3. Configure the PXIe-5655 as the Associated LO for the PXIe-5842 in Measurement & Automation Explorer (MAX).
4. Connect the frequency reference source to the REF IN connector on the PXI Express chassis with a standard SMA (m) to BNC (m) cable. Connect all instruments REF IN connections to the same reference source.
5. Launch the Calibration Executive procedure. Calibration Executive guides you through the required connections.

## Hardware Licensing Considerations

Calibration Executive will automatically detect the licensed functionality associated with the PXIe-5842 under test. The verification test points will be limited to only the functionality included with the license of the device.

## External SMA-100B IMD3 Failure Considerations

At the beginning of the procedure, Calibration Executive characterizes the IMD3 performance of the two SMA-100B signal generators and associated fixtures that you use for the PXIe-5842 RF Input IIP3 verification. Calibration Executive does not include these characterization results in the calibration report. The IMD3 characterization must pass to proceed with the PXIe-5842 verification. If the IMD3 characterization fails repeatedly, check the connections, and evaluate if the devices or fixtures require repair or replacement.

## Fixture Characterization Considerations

The RF Input and Output tests require fixtures that are characterized at the beginning of the procedure. Calibration Executive does not support saving characterization data between separate procedure runs. For a characterization to maintain its validity during calibration, ensure that no portion of the fixture is disconnected or modified during the procedure run. Avoid re-torquing any part of the fixture.

The following figures indicate the portion of the fixtures that must remain intact during use.

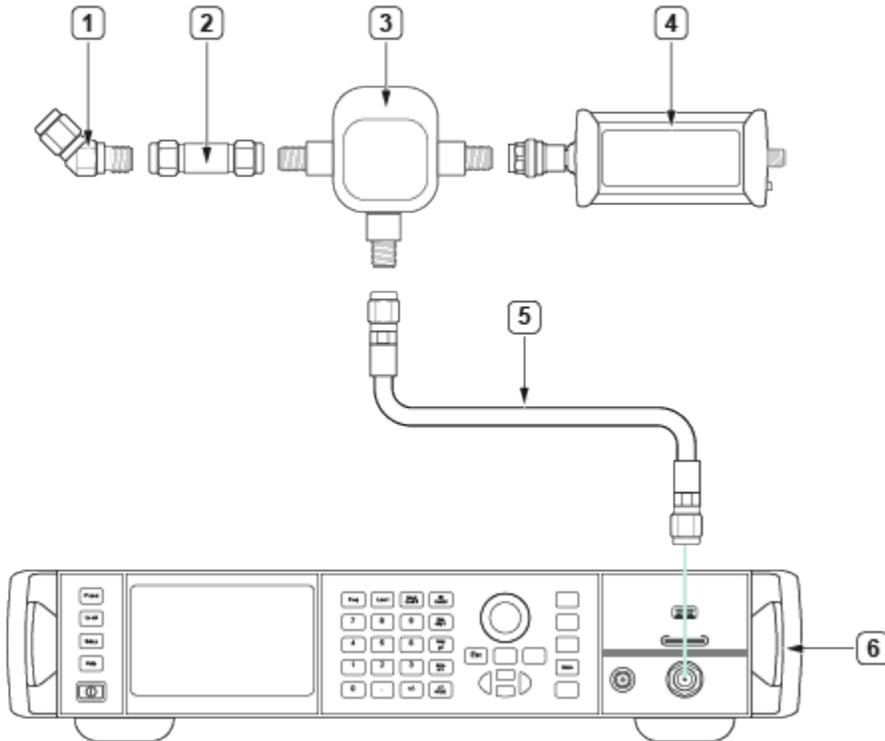
**Figure 1.** Initial Connection for Receiver Fixture Characterization

1. 45-degree SMA (m) to SMA (f) adapter
2. 3.5 mm (m) to 3.5 mm (m) adapter
3. 3.5 mm power splitter (two-resistor type)
4. Power Sensor #1
5. 3.5 mm (m) to (m) cable
6. Signal Generator

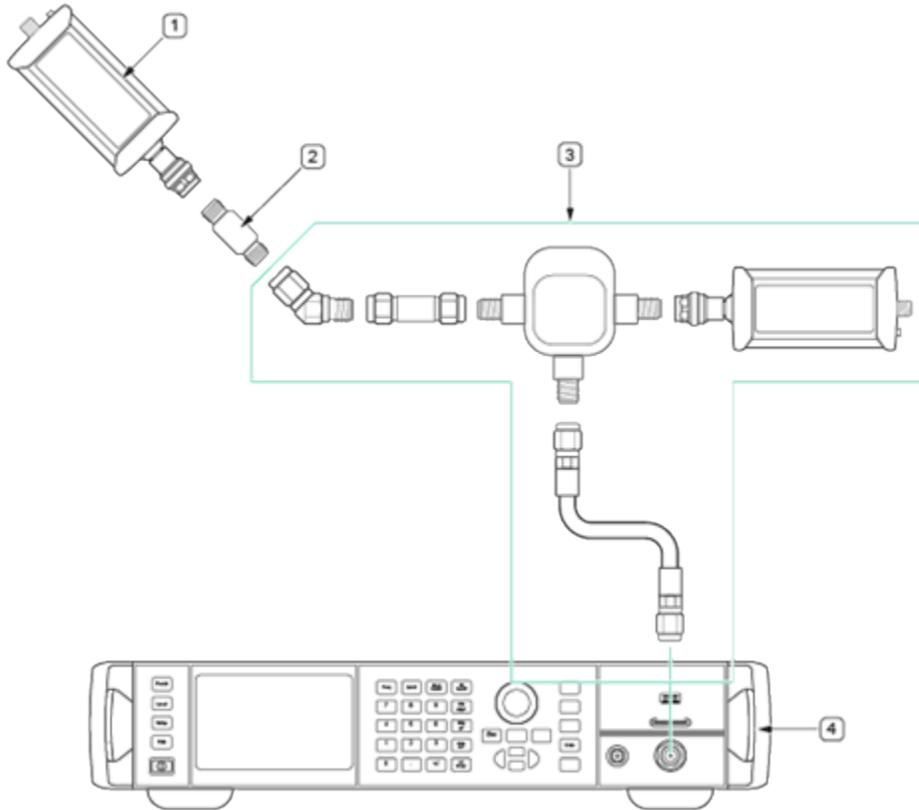
**Figure 1.** Final Measurement Connections for Receiver Fixture Characterization

1. Power Sensor #2
2. 3.5 mm (f) to 3.5 mm (f) adapter
3. Receiver Fixture from Figure 1
4. Signal Generator

**Figure 1.** Connection for Transmit Cable Loss Characterization

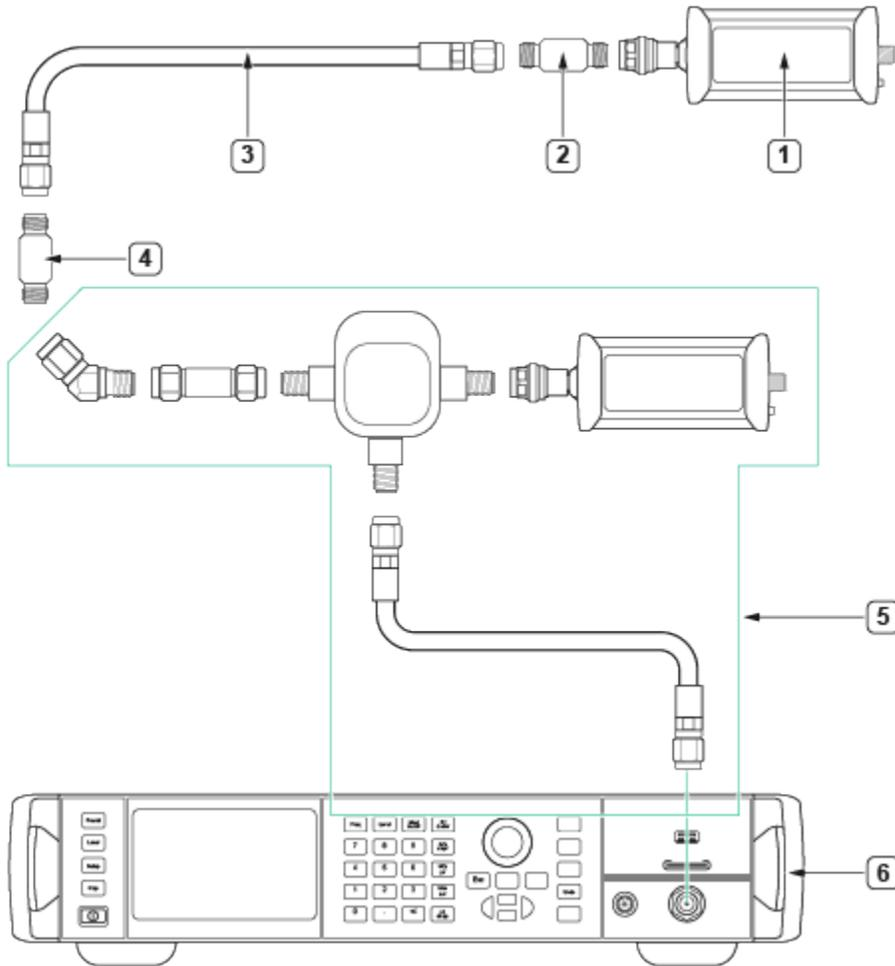

1. Power Sensor #2
2. 3.5 mm (f) to 3.5 mm (f) adapter
3. 3.5 mm (m) to (m) cable
4. SMA (f) to SMA (f) adapter
5. Receiver Fixture from Figure 1
6. Signal Generator

## Adjustment Considerations

Perform all adjustments steps without significant idle time between connection changes. The internal device temperature must maintain  $\pm 2$  °C stability for the duration of the adjustment. If the device does not maintain stability, or if you encounter an error during an adjustment step, retry or re-run Adjustment Only to resolve the problem. If the adjustment step repeatedly causes an error, repair the

PXIe-5842 or replace it with another module.

## NI Wireless Test System (WTS) Calibration Procedure

Calibrate the NI Wireless Test System (WTS) using Calibration Executive.

### Calibration Executive Procedure Features

Verify Only ✓	Adjust Only ✓	Verify & Adjust ✓	Manual Mode ✗	Optional Adjust ✗
---------------	---------------	-------------------	---------------	-------------------

### Approximate Test Time

Device	Verify Only	Adjust Only	Verify & Adjust
WTS-01, -02, -03, -04	80 minutes	80 minutes	240 minutes
WTS-05	160 minutes	160 minutes	480 minutes

### Test Equipment

The following table lists the test instruments required for calibrating the WTS.

**Table 312.** Test equipment for calibrating the NI Wireless Test System

Instrument	Recommended Model	Minimum Requirements
Frequency reference	Symmetricon 8040 Rubidium Frequency Standard	Frequency: 10 MHz Frequency accuracy: $\pm 1E-9$
Power sensor	Rohde & Schwarz NRP-Z91 with NRP-Z4 USB adapter	Range: -67 dBm to +23 dBm Frequency range: 65 MHz to 6 GHz Accuracy: 0.5% VSWR: <1.2 at 6 GHz

Instrument	Recommended Model	Minimum Requirements
Vector signal generator	PXIe-5673E (NI 5673)	<p>Frequency range: 65 MHz to 6 GHz</p> <p>Frequency resolution: &lt;5 Hz</p> <p>Amplitude range: -60 dBm to 0 dBm</p> <p>Instantaneous bandwidth: 50 MHz</p>
Spectrum analyzer or vector signal analyzer	PXIe-5665 (NI 5665)	<p>Frequency range: 65 MHz to 6 GHz</p> <p>Noise floor at 6 GHz: &lt;-158 dBm/Hz</p> <p>Instantaneous bandwidth: 50 MHz</p> <p>Phase noise at 20 kHz offset: &lt;-125 dBm/Hz</p>
Preamplifier	PXI-5691 (NI 5691) (x2)	<p>Frequency range: 65 MHz to 6 GHz</p> <p>Noise floor at 6 GHz: &lt;-158 dBm/Hz</p> <p>Instantaneous bandwidth: 50 MHz</p> <p>Phase noise at 20 kHz offset: &lt;-125 dBm/Hz</p>
6 dB attenuator (x3)	Anritsu 41KB-6 or Mini-Circuits	<p>Frequency range: DC to 6 GHz</p> <p>VSWR: 1.1</p>

Instrument	Recommended Model	Minimum Requirements
Cables/Adapters: <ul style="list-style-type: none"> <li>• SMA (m)-to-SMA (m) cables</li> <li>• SMA (f)-to-N (m) adapters</li> <li>• SMA (m)-to-N (f) adapter</li> </ul>	—	Frequency range: DC to 6 GHz  Impedance: 50 $\Omega$
Type N torque wrench*	Fairview Type N Fixed Torque Wrench in Click Type, pre-set to 13 in-lbs	Type N torque wrench pre-set to 13 in-lbs



**Note** \*Choose the bit size of the torque wrench based on the size of the N-type adapter.

## Test Conditions

The following setup and environmental conditions are required to ensure the NI WTS meets published specifications.

- Keep cabling as short as possible. Long cables act as antennas, picking up extra noise that can affect measurements.
- Verify that all connections, including front panel connections and screws, are secure.
- Maintain an ambient temperature of  $23\text{ }^{\circ}\text{C} \pm 5\text{ }^{\circ}\text{C}$ .
- Keep the relative humidity between 10% and 90%, noncondensing.
- Allow a warm-up time of at least 30 minutes after the WTS and instrument chassis are powered on. The warm-up time ensures that the NI WTS and test instrumentation are at a stable operating temperature.
- Ensure that the NI WTS and PXI Express chassis fan speeds are set to HIGH, that the fan filters (if present) are clean, and that the empty slots contain filler panels and slot blockers. For more information about chassis cooling, refer to the ***Maintain Forced-Air Cooling Note to Users*** document available at [ni.com/docs](http://ni.com/docs).



## Device Setup

1. Use a monitor, a USB keyboard, and a mouse, and confirm that the WTS device is logged in and that the software is loaded. The WTS Instrument software must be loaded in order for external communication to be established with the device.
2. Ensure that the WTS is connected to the same subnet as the system running Calibration Executive. Note that Ethernet port 2 on the WTS is configured for DHCP by default
3. Configure the hardware using Measurement & Automation Explorer (MAX). Refer to the NI Wireless Test System Getting Started Guide, available at [ni.com/docs](http://ni.com/docs), for troubleshooting information.
4. Launch the Calibration Executive procedure. Calibration Executive guides you through the required connections.



**Note** You must have at least 4 GB of memory on your system to run this procedure.



**Notice** Using this command incorrectly can render your computer inoperable. Refer to Microsoft documentation on the `BCDEdit /set` command for more details. This command reduces the kernel address space available for Windows from 2 GB to 1 GB.

## Test Limit Equations

The following test limits are derived from the published specifications.

**Table 294.** NI Wireless Test System (WTS) Test Limit Equations

Equation Type	Equation
Internal Frequency Reference Accuracy	$\text{TestLimits} = (\text{InitialAccuracy} + \text{TemperatureStability}) + \text{Aging}$

If Calibration Executive detects that the WTS device under test has not previously been adjusted, then the as found performance of the device will not be considered warranted, and the as found limits will reflect the unadjusted performance of the device. For more information, go to [ni.com/info](http://ni.com/info) and enter the Info Code `WTScalibrate`.

**Related information:**

- ["Not Warranted" Message in Calibration Report for WTS Device](#)

## Signal Generators

Calibrate your signal generators with Calibration Executive.

### NI 5402/5406 Calibration Procedure

Calibrate the NI 5402/5406 using Calibration Executive.

### Calibration Executive Procedure Features

Verify Only ✓	Verify & Adjust ✓	Manual Mode ✓	Optional Adjust ✗
---------------	-------------------	---------------	-------------------

### Approximate Test Time

10 minutes

### Test Equipment

The following table lists the test equipment required for calibrating NI 5402/5406 modules.

**Table 312.** Test equipment for calibrating the NI 5402/5406

Instrument	Recommended Model	Requirements
DMM	NI 4070, Agilent 34401A	If these instruments are unavailable, use a DMM with a DC accuracy of $\leq \pm 50$ ppm and resolution $\leq 1$ $\mu$ V.
Frequency Counter	Agilent 53131A with timebase option 010	If this instrument is unavailable, use a frequency counter with the ability to measure 10 MHz or higher sine waves and a frequency accuracy of $\pm 500$ ppb.
Power Meter	Agilent E4419B with Agilent E9304A	If these instruments are unavailable, use a power meter with a power accuracy of $\pm 0.10$ dB that can measure flatness from

Instrument	Recommended Model	Requirements
	power sensor	50 kHz to 50 MHz.
Chassis	PXI-1042, PXI-1042Q	Use with PXI modules.
BNC to SMB Cable	—	Use a 50 $\Omega$ male BNC to female SMB cable.
BNC to Banana Plug Adapter	—	Use a female BNC to male banana plug adapter.

## Test Conditions

The following setup and environmental conditions are required to ensure the NI 5402/5406 meets published specifications.

- Keep connections to the NI 5402/5406 short. Long cables and wires act as antennas, picking up extra noise that can affect measurements.
- Keep relative humidity between 10 and 90% non-condensing.
- Maintain a temperature between 18 and 28 °C.
- Allow a warm-up time of at least 15 minutes to ensure that the measurement circuitry of the device is at a stable operating temperature.
- Plug the PXI chassis or PC and the calibrator into the same power strip to avoid ground loops.
- (PXI) Ensure that the PXI chassis fan speed is set to HIGH, that the fan filters are clean, and that the empty slots contain filler panels.

## Device Setup

The device must be configured in Measurement & Automation Explorer (MAX) to communicate with NI-FGEN.

1. Install the NI-FGEN driver software.
2. Power off the computer or chassis that will hold the device and install the device in

an available slot.

3. Power on the computer or chassis and launch MAX.
4. Configure the device identifier and select **Self-Test** to ensure that the device is working properly.
5. Launch the Calibration Executive procedure and complete the setup wizard.



## Note

- When a device is configured with MAX, it is assigned a device identifier. This device identifier is used to open an NI-FGEN session. For more information about configuring and testing your device in MAX, refer to the ***NI Signal Generators Getting Started Guide***.
- If the NI 5402/5406 module fails after calibration, return it to NI for repair or replacement.

## Test Limit Equations

The following test limits are derived from the published specifications.

**Table 296.** NI 5402/5406 Test Limit Equations

Equation Type	Equation
Oscillator Frequency	$\text{TestLimits} = \text{Test Frequency} \pm [\text{Test Frequency} * \text{Frequency Accuracy}(\text{ppm})]$
DC Gain and Offset	$\text{TestLimits} = \text{TestValue} \pm (0.5\% \text{ of Offset} + 2 \text{ mV} + 0.5\% \text{ of Amplitude})$
Square Wave Gain and Offset	$\text{TestLimits} = \text{TestValue} \pm (0.5\% \text{ of Offset} + 2 \text{ mV} + 0.5\% \text{ of Amplitude})$
Sine Wave Flatness	$\text{TestLimits} = \text{TestValue} \pm (\text{TestValue} * 0.4\text{dB})$ <ul style="list-style-type: none"> <li>• Specification for passband flatness is +/- 0.4 dB relative to 50 kHz</li> </ul>

**Related concepts:**

- [Launching a Calibration Procedure](#)

## PXI-5404 Calibration Procedure

Calibrate the PXI-5404 using Calibration Executive.

### Calibration Executive Procedure Features

Verify Only ✓	Verify & Adjust ⓧ	Manual Mode ✓	Optional Adjust ⓧ
---------------	-------------------	---------------	-------------------

### Approximate Test Time

5 minutes

### Test Equipment

The following table lists the test equipment required for calibrating PXI-5404 modules.

**Table 312.** Test equipment for calibrating the PXI-5405

Instrument	Recommended Model	Parameter Measured	Requirements
DMM	NI 4070, Agilent 34401A, Keithley 2000	SINE Out Amplitude Accuracy	AC amplitude accuracy better than $\pm 0.1\%$ at 50 kHz at 4 V <sub>pk-pk</sub>
Frequency Counter	Agilent 53131A, Agilent 53132A with timebase option 010	Frequency Accuracy	Bandwidth >150 MHz, Frequency accuracy to $\pm 500$ ppb
Oscilloscope	Tektronix TDS3054	CLOCK Out Duty Cycle Accuracy	Bandwidth $\geq 500$ MHz, Timebase Accuracy: $\leq 200$ ppm
Power Meter and Thermal Power Sensor	Rohde & Schwarz NRP-Zxx Meter Rohde & Schwarz NRP-	SINE Out Amplitude Passband Flatness	$\pm 0.12$ dB accuracy for flatness measurements from 9 kHz to 105 MHz

Instrument	Recommended Model	Parameter Measured	Requirements
	Z91 with NRP-Z4 USB adapter		
BNC (f) to Double Banana Plug Adapter	—	SINE Out Amplitude Accuracy	—
BNC (m) to SMB (f) Cable	—	SINE Out Amplitude Accuracy	50 $\Omega$
SMA (m) to SMB (f) Cable	—	Frequency Accuracy	—
BNC (m) to SMB (f) Cable	—	CLOCK Out Duty Cycle Accuracy	—
N-Type (f) to SMB (f) Cable	—	SINE Out Amplitude Passband Flatness	50 $\Omega$
Chassis	PXI-1042, PXI-1042Q	All Parameters	—

## Test Conditions

The following setup and environmental conditions are required to ensure the PXI-5404 meets published specifications.

- Keep connections to the device as short as possible. Long cables and wires act as antennas, picking up extra noise that can affect measurements.
- Keep relative humidity below 80%.
- Maintain a temperature between 18 and 28 °C.
- Ensure that the PXI chassis fan speed is set to HIGH, that the fan filters are clean, and that the empty slots contain filler panels.

## Device Setup

The device must be configured in Measurement & Automation Explorer (MAX) to

communicate with NI-FGEN.

1. Install the NI-FGEN driver software.
2. Power off the chassis that will hold the device.
3. Install the device in an available slot.
4. Power on the chassis and launch MAX.
5. Configure the device identifier and select **Self-Test** to ensure that the device is working properly.
6. Launch the Calibration Executive procedure and complete the setup wizard.



**Note** When a device is configured with MAX, it is assigned a device identifier. This device identifier is used to open an NI-FGEN session. For more information about configuring and testing your device in MAX, refer to the NI Signal Generators Getting Started Guide. If the PXI-5404 module fails after calibration, return it to NI for repair or replacement.

## Test Limit Equations

The following test limits are derived from the published specifications.

**Table 298.** PXIe-5404 Test Limit Equations

Equation Type	Equation
Frequency Accuracy	$\text{TestLimits} = \text{TestValue} (10 \text{ MHz}) \pm \text{Absolute Accuracy} (60 \text{ Hz})$ <ul style="list-style-type: none"> <li>• Absolute Accuracy = <math>\pm 25</math> ppm</li> </ul>
SINE Out Amplitude Accuracy	$\text{TestLimits} = \text{TestValue} (1.41421 V_{\text{rms}}) \pm \text{Absolute Accuracy} (0.0141421 V_{\text{rms}})$ <ul style="list-style-type: none"> <li>• Absolute Accuracy = <math>\pm 1\%</math> or <math>0.0141421 V_{\text{rms}}</math> <ul style="list-style-type: none"> <li>◦ <math>\pm 1\%</math> at 50 kHz</li> </ul> </li> </ul>
SINE Out Amplitude Passband Flatness	$\text{TestLimits} = \pm 0.2 \text{ dB}$ <ul style="list-style-type: none"> <li>• <math>\pm 0.2</math> dB relative to the amplitude at 50 kHz</li> </ul>

Equation Type	Equation
CLOCK Out Duty Cycle Accuracy	$\text{TestLimits} = \text{TestValue} (50\%) \pm \text{Absolute Accuracy} (2\%)$ <ul style="list-style-type: none"> <li>Absolute Accuracy = <math>\pm 2\%</math></li> </ul>

### Related concepts:

- [Launching a Calibration Procedure](#)

## NI 5412/5421/5422/5441/5442 Calibration Procedure

Calibrate the NI 5412/5421/5422/5441/5442 using Calibration Executive.

### Calibration Executive Procedure Features

Verify Only ✓	Verify & Adjust ✓	Manual Mode ✓	Optional Adjust ✗
---------------	-------------------	---------------	-------------------

### Approximate Test Time

Device	Test Time
PCI-5412/PXI-5412	25 minutes
PCI-5421/PXI-5421/PXI-5441	40 minutes
PXI-5422/PXIe-5442	30 minutes

### Test Equipment

The following table lists the test equipment required for calibrating NI 5412/5421/5422/5441/5442 devices.

**Table 312.** Test equipment for calibrating the NI 5412/5421/5422/5441/5442

Instrument	Recommended Model	Specification	Requirements
Chassis	PXI-1042, PXI-1042Q	All	Use with PXI modules



Instrument	Recommended Model	Specification	Requirements
	PXIe-1062Q	All	Use with PXI Express modules
Digital multimeter (DMM)	PXI-4070	AC accuracy, DC gain and offset, Frequency accuracy	DCV accuracy: $\leq 0.05\%$ DC input impedance: $\geq 1 \text{ G}\Omega$ ACV accuracy: $\leq 0.16\%$ AC input impedance: $\geq 1 \text{ M}\Omega$ Bandwidth: $\geq 100 \text{ kHz}$ DC Accuracy: $\leq \pm 50 \text{ ppm}$ Resolution: $\leq 1 \mu\text{V}$
Banana(m)-to-BNC(f) adapter	—		—
BNC(m)-to-SMB(f) cable	—		50 $\Omega$ , RG-233
Frequency counter or frequency meter	Agilent/HP 53131A or HP 53132A with timebase option 001, 010, or 012	Frequency accuracy	Ability to measure 10 MHz or higher sine waves Frequency accuracy to $\pm 500 \text{ ppb}$
Power meter/sensor	Rohde & Schwarz NRP-Z91 with NRP-Z4 USB adapter	Frequency response (flatness)	VSWR: (50 kHz to 120 MHz) $\leq 1.11$ Relative power accuracy: $\leq 0.022 \text{ dB}$

Instrument	Recommended Model	Specification	Requirements
Type N(f)-to-SMB plug adapter	Pasternack PE9316		VSWR: 1.3

## Test Conditions

The following setup and environmental conditions are required to ensure the NI 5412/5421/5422/5441/5442 meets published specifications.

- Keep connections to the device as short as possible. Long cables and wires act as antennas, picking up extra noise that can affect measurements.
- Keep relative humidity below 80%.
- Maintain a temperature between 18 °C and 28 °C.
- Allow a warm-up time of at least 15 minutes to ensure that the measurement circuitry of the device is at a stable operating temperature.
- Allow the DMM to warm up for its recommended warm-up interval.
- (PXI/PXI Express) Ensure that the PXI/PXI Express chassis fan speed is set to HIGH, that the fan filters are clean, and that the empty slots contain filler panels. For more information, refer to the Maintain Forced-Air Cooling Note to Users documents available at [ni.com/docs](http://ni.com/docs).

## Device Setup

1. Install the NI hardware in the PXI chassis or the PC according to the instructions in the .
2. Configure the hardware using Measurement & Automation Explorer (MAX).
3. Launch the Calibration Executive procedure and complete the setup wizard.



**Note** If the device fails after calibration, return it to NI for repair or replacement.

## Test Limit Equations

The following test limits are derived from the published specifications for individual models.

Table 300. NI 5412/5421/5422/5441/5442 Test Limit Equations

Equation Type	Equation
Oscillator Frequency	$\text{TestLimits} = \text{TestFrequency} \pm [\text{TestFrequency} * \text{FrequencyAccuracy} (25 \text{ ppm})]$
DC Gain and Offset	<p>Main Analog Path Gain</p> <ul style="list-style-type: none"> <li>• <math>\text{TestLimits} = \text{TestValue} \pm (0.2\% \text{ of Amplitude} + 500 \mu\text{V})</math></li> </ul> <p>Main Analog Path Offset</p> <ul style="list-style-type: none"> <li>• <math>\text{TestLimits} = \text{TestValue} \pm (0.05\% \text{ of Offset} + 500 \mu\text{V} + 0.2\% \text{ of Amplitude})</math></li> </ul> <p>Direct Path Gain</p> <ul style="list-style-type: none"> <li>• <math>\text{TestLimits} = \text{TestValue} \pm (0.2\% \text{ of Amplitude})</math></li> </ul> <p>Direct Path Offset (Verification Only)</p> <ul style="list-style-type: none"> <li>• <math>\text{TestLimits} = \text{TestValue} \pm (\text{TestValue} * 0.03 \text{ V})</math></li> </ul>
AC Voltage Amplitude	<p><math>\text{TestLimits}_* = (+2.0\% + 1 \text{ mV}), (-1.0\% - 1 \text{ mV}), (+0.8\% + 0.5 \text{ mV}), (-0.2\% - 0.5 \text{ mV})</math></p> <ul style="list-style-type: none"> <li>• * With a 50 kHz sine wave and terminated with high impedance.</li> </ul>
Frequency Response (Flatness)	Limits taken from specifications.



**Note** Flatness test limits were updated in this procedure to match the PXIe-5442 Specifications (372127D-01) document.

#### Related concepts:

- [Launching a Calibration Procedure](#)

## PXIe-5413/5423/5433 Calibration Procedure

Calibrate the PXIe-5413/5423/5433 using Calibration Executive.

### Calibration Executive Procedure Features

Verify Only ✓	Verify & Adjust ✓	Manual Mode ✓	Optional Adjust ✗
---------------	-------------------	---------------	-------------------

### Approximate Test Time

Warmup	Verify Only	Verify & Adjust
15 minutes	15 minutes	50 minutes

### Test Equipment

The following table lists the test equipment required for calibrating PXIe-5413/5423/5433 modules.

**Table 312.** Test equipment for calibrating the PXIe-5413/5423/5433

Instrument	Recommended Model	Minimum Requirements
Oscilloscope*	PXIe-5162	Frequency resolution: 0.1 Hz Ability to measure sine waves $\geq 10$ MHz with amplitudes of $2 V_{pk-pk}$ to $5 V_{pk-pk}$ with $50 \Omega$ input impedance.
SMA (m)-to-SMA (m) cable	—	Frequency range: DC to 100 MHz Impedance: $50 \Omega$ Length: $< 1$ m
Precision frequency reference	PXIe-6674T or Rubidium reference	Frequency accuracy: 100 ppb Ability to PLL lock to the oscilloscope.
DMM	PXI-4071	DC voltage range: $\pm 5$ V

Instrument	Recommended Model	Minimum Requirements
		DC voltage accuracy: <40 ppm AC voltage accuracy: $\pm 0.1\%$ of reading at 50 kHz AC Input Range: 0.05 $V_{RMS}$ to 5 $V_{RMS}$ AC Input Impedance: $\geq 10\text{ M}\Omega$ Bandwidth: $\geq 100\text{ kHz}$
Double banana plug-to-BNC (f)	Pasternack PE9008	Impedance: 50 $\Omega$
SMA (m)-to-BNC (m) cable	—	Frequency range: DC to 1 MHz Impedance: 50 $\Omega$ Length: <1 m
Power sensor	Rohde & Schwarz NRP-Z91	Range: -30 dBm to 23 dBm Frequency range: 50 kHz to 100 MHz Absolute Power Accuracy: <0.048 dB for <100 MHz Relative Power Accuracy: <0.022 dB for <100 MHz VSWR: <1.11
SMA (m)-to-N (f) adapter	—	Frequency range: DC to 100 MHz Impedance: 50 $\Omega$



**Note** \*The Oscilloscope standard cannot be used in manual mode.

## Test Conditions

The following setup and environmental conditions are required to ensure the PXIe-5413/5423/5433 meets published specifications.

- Keep cabling as short as possible. Long cables and wires act as antennas, picking up extra noise that can affect measurements.
- Allow the PXIe-5413/5423/5433 to warm up for 15 minutes at ambient temperature. Warmup begins after the chassis is powered and the module is recognized by the host and configured using NI-FGEN.
- Allow all test instruments to warm up for at least the period of time stated in the documentation for each instrument. The warm-up time ensures that the test instruments are at a stable operating temperature.
- Verify that all connections, including front panel connections and screws, are secure.
- Use shielded copper wire for all cable connections to the device. Use twisted-pair wire to eliminate noise and thermal offsets.
- Maintain a temperature of  $23^{\circ}\text{C} \pm 3^{\circ}\text{C}$ .
- Keep relative humidity between 10% and 90%, noncondensing.
- Ensure that the PXI chassis fan speed is set to HIGH, that the fan filters are clean, and that the empty slots contain filler panels. For more information, refer to the ***Maintain Forced-Air Cooling Note to Users*** documents available at [ni.com/docs](http://ni.com/docs).
- Plug the PXI chassis and any other instrument standards into the same power strip to avoid ground loops.

## Device Setup

1. Install the NI 5413/5423/5433 in the PXI chassis according to the instructions in the Getting Started Guide.
2. Configure the hardware using Measurement & Automation Explorer (MAX).
3. Launch the Calibration Executive procedure and complete the setup wizard.



**Note** If the NI 54xx module fails after calibration, return it to NI for repair or replacement.

## Test Limit Equations

The following test limits are derived from the published specifications.

**Table 302.** PXIe-5413/5423/5433 Test Limit Equations

Equation Type	Equation
Timebase Accuracy	<p>1.5 ppm <math>\pm</math> Time Drift, warranted</p> <p>Time Drift = 1 ppm per year, warranted (where time drift starts at the latest external calibration date)</p> <div style="border-left: 2px solid black; padding-left: 10px; margin-top: 10px;">  <p><b>Note</b> If locked to an external Reference Clock source, timebase accuracy is equal to the external Reference Clock accuracy.</p> </div>
DC Accuracy	<p>Within <math>\pm 5</math> °C of self-calibration temperature</p> <p><math>\pm 0.35\%</math> of Amplitude Range <math>\pm 0.35\%</math> of Offset Requested <math>\pm 500</math> <math>\mu</math>V, warranted</p>
AC Amplitude Accuracy	<p>Within <math>\pm 5</math> °C of self-calibration temperature</p> <p><math>\pm 1.0\% \pm 1</math> mV<sub>pk-pk</sub>, warranted</p>
Passband Flatness	<p>Refer to the PXIe-5413 Specifications, PXIe-5423 Specifications, or PXIe-5433 Specifications as appropriate for information about passband flatness.</p>

### Related concepts:

- [Launching a Calibration Procedure](#)

## PXIe-5450 Calibration Procedure

Calibrate the PXIe-5450 using Calibration Executive.

### Calibration Executive Procedure Features

Verify Only ✓	Verify & Adjust ✓	Manual Mode ✓	Optional Adjust ✗
---------------	-------------------	---------------	-------------------

### Approximate Test Time

180 minutes

### Test Equipment

The following table lists the test equipment required for calibrating PXIe-5450 modules.

**Table 312.** Test equipment for calibrating the PXIe-5450

Instrument	Recommended Model	Parameter Measured	Requirements
DMM	PXI-4071	DC Amplitude Accuracy, DC Amplitude AC Amplitude Channel-to-Channel Relative Accuracy, Differential Offset, Common Mode Offset, AC Amplitude Accuracy, Channel-to-Channel Relative Accuracy,	DCV Accuracy: $\leq 0.05\%DCV$ Input Impedance: $\geq 1\text{ G}\Omega ACV$ Accuracy: $\leq 0.13\%ACV$ Input Impedance: $\geq 10\text{ M}\Omega$ Bandwidth: $\geq 100\text{ kHz}$



Instrument	Recommended Model	Parameter Measured	Requirements
		DC ADC and Reference Adjustment	
Digital Oscilloscope (DPO)	Tektronix DPO7104C	Channel-to-Channel Timing Alignment Accuracy	Analog Bandwidth: $\geq 4$ GHz ( $-3$ dB) Real-Time Sample Rate: 25 GS/s Jitter Noise Floor: $\leq 450$ fs
Power Meter/Sensor (x2)	Rohde & Schwarz NRP-Z91 with NRP-Z4 USB adapter	Frequency Response (Flatness) Accuracy, Channel-to-Channel Frequency Response (Flatness) Matching Accuracy, Frequency Response (Flatness) Adjustment	VSWR (50 kHz to 120 MHz): $\leq 1.11$ Relative Power Accuracy: $\leq 0.022$ dB
Fixed 7 dB SMA Attenuator (x2)	Mini-Circuits VAT-7-1+	Frequency Response (Flatness) Accuracy, Channel-to-Channel Frequency Response (Flatness) Matching Accuracy, Frequency Response (Flatness) Adjustment	VSWR (50 kHz to 120 MHz): 1.02:1 Flatness (50 kHz to 60 MHz): 0.05 dB Flatness (60 MHz to 120 MHz): 0.07 dB

Instrument	Recommended Model	Parameter Measured	Requirements
Semi-Rigid Coaxial Cable (x2)	Anritsu K120MF-5CM	Frequency Response (Flatness) Accuracy, Channel-to-Channel Frequency Response (Flatness) Matching Accuracy, Frequency Response (Flatness) Adjustment	2 in (m)(f) 50 Ω ±2 Ω Attenuation: ≤ 1.6 dB/m at 1 GHz Flatness (50 kHz to 120 MHz): 0.001 dB
Spectrum Analyzer	R&S FSU26 with FSU-B23 20 dB Preamplifier	Average Noise Density, Internal Reference Clock Frequency Accuracy	Frequency Accuracy: ≤ 100 Hz Requirements for the following parameters must be better than or equal to the equipment recommended for f ≤ 200 MHz: <ul style="list-style-type: none"> <li>• Total Level Measurement Uncertainty</li> <li>• Displayed Average Noise Level SSB Phase Noise ( 1 Hz)</li> <li>• Intermodulation Distortion</li> <li>• Total Harmonic Distortion</li> <li>• Spurious Free Dynamic Range</li> <li>• Reference Frequency</li> <li>• RF Input VSWR</li> </ul>
BALUN	Picosecond 5320B	Average Noise Density, Internal Reference Clock Frequency Accuracy	BW ≥ 500 MHz Impedance: 50 Ω (100 Ω Differential) Differential Balance ≤ 0.2 dB Return Loss > 20 dB Rise Time < 500 ps
SMA 50 Ω High Quality Cables (x4)	—	—	Maximum Length: 1 ft

Instrument	Recommended Model	Parameter Measured	Requirements
			Matching Length: $\leq \pm 1$ ps at 200 MHz
SMA Torque Wrench	—	—	Coupling Torque: 56 N-cm (5 in/lb)
Chassis	PXIe-1062Q	—	—

## Test Conditions

The following setup and environmental conditions are required to ensure the PXIe-5450 meets published specifications.

- Keep connections to the PXIe-5450 short. Long cables and wires act as antennas, picking up extra noise that can affect measurements.
- Keep relative humidity between 10% and 90% noncondensing.
- Maintain a temperature between 18 and 28 °C.
- Allow a warm-up time of at least 30 minutes after powering on all hardware, loading the operating system, and, if necessary, enabling the device. Unless manually disabled, the NI-FGEN driver automatically loads with the operating system and enables the device. The warm-up time brings the measurement circuitry of the PXIe-5450 to a stable operating temperature.
- Ensure that the PXI Express chassis fan speed is set to HIGH, that the fan filters are clean, and that the empty slots contain filler panels.
- Plug the PXI Express chassis and the calibrator into the same power strip to avoid ground loops.

## Device Setup

1. Install the PXIe-5450 in the PXI Express chassis according to the instructions in the NI Signal Generators Getting Started Guide.
2. Configure the hardware using Measurement & Automation Explorer (MAX).
3. Launch the Calibration Executive procedure and complete the setup wizard.



**Note** If the PXIe-5450 module fails after calibration, return it to NI for repair

or replacement.

### Related concepts:

- [Launching a Calibration Procedure](#)

## PXIe-5451 Calibration Procedure

Calibrate the PXIe-5451 using Calibration Executive.

### Calibration Executive Procedure Features

Verify Only ✓	Verify & Adjust ✓	Manual Mode ✗	Optional Adjust ✗
---------------	-------------------	---------------	-------------------

### Approximate Test Time

Verify Only	Verify & Adjust
90 minutes	240 minutes

### Test Equipment

The following table lists the test equipment required for calibrating the PXIe-5451 module.

**Table 312.** Test equipment for calibrating the PXIe-5451

Instrument	Recommended Model	Specifications	Requirements
Digital Multimeter (DMM)	PXI-4071	<ul style="list-style-type: none"> <li>• DC Amplitude/AC Amplitude Channel-to-Channel Relative Accuracy</li> <li>• Differential and Single-Ended Offset</li> </ul>	DCV accuracy: $\leq 0.05\%$ DCV input impedance: $\geq 1 \text{ G}\Omega$ ACV accuracy: $\leq 0.13\%$ ACV input impedance: $\geq 10 \text{ M}\Omega$ Bandwidth: $\geq 100 \text{ kHz}$

Instrument	Recommended Model	Specifications	Requirements
		<ul style="list-style-type: none"> <li>Common Mode Offset</li> <li>AC Amplitude Accuracy</li> </ul>	
Digital Oscilloscope (DPO)	Tektronix DPO7104C	<ul style="list-style-type: none"> <li>Channel-to-Channel Timing Alignment Accuracy</li> </ul>	Analog bandwidth: $\geq 4$ GHz (-3 dB) Real-time sample rate: 25 GS/s Jitter noise floor: $\leq 450$ fs
Power Meter/Sensor (x2)	Rohde & Schwarz NRP-Z91 with NRP-Z4 USB adapter	<ul style="list-style-type: none"> <li>Frequency Response (Flatness) Accuracy</li> <li>Channel-to-Channel Frequency Response (Flatness) Matching Accuracy</li> </ul>	VSWR: (50 kHz to 120 MHz) $\leq 1.11$ Relative power accuracy: $\leq 0.022$ dB
Type N(f) to SMA(m) Adapter	Maury 8816B		VSWR: (DC to 4 GHz) $< 1.05$
Fixed 7 dB SMA attenuator (x2)	Mini-Circuits VAT-7-1+		VSWR (50 kHz to 120 MHz): 1.02:1 Flatness (50 kHz to 60 MHz): 0.05 dB Flatness (60 MHz to 120 MHz): 0.07 dB
Semi-Rigid Coaxial Cable K(m)-K(f) 5 cm (x2)	Anritsu K120MF-5CM		2 in (m)(f) $50 \Omega \pm 2 \Omega$ Attenuation $\leq 1.6$ dB/m at 1 GHz Flatness (50 kHz to 120 MHz): 0.001 dB
Spectrum Analyzer	Rohde & Schwarz FSU26 or FSUP  Required options:		<ul style="list-style-type: none"> <li>Average Noise Density</li> <li>Internal Reference Clock Frequency Accuracy</li> </ul>

Instrument	Recommended Model	Specifications	Requirements
	<ul style="list-style-type: none"> <li>FSU-B23 20 dB preamplifier</li> <li>FSU-B25 electronic attenuator</li> </ul>		<ul style="list-style-type: none"> <li>Total level measurement uncertainty</li> <li>Displayed average noise level SSB phase noise (1 Hz)</li> <li>Intermodulation Distortion</li> <li>Total harmonic distortion</li> <li>Spurious free dynamic range</li> <li>Reference frequency</li> <li>RF input VSWR</li> </ul>
BALUN	Picosecond 5320B	<ul style="list-style-type: none"> <li>Average Noise Density</li> <li>Internal Reference Clock Frequency Accuracy</li> </ul>	<p>BW <math>\geq</math> 500 MHz</p> <p>Impedance: 50 <math>\Omega</math> (100 <math>\Omega</math> differential)</p> <p>Differential balance <math>\leq</math> 0.2 dB</p> <p>Return loss &gt; 20 dB</p> <p>Rise time &lt; 500 ps</p>
SMA torque wrench	—	—	Coupling torque: 56 N-cm (5 lb · in.)
SMA 50 $\Omega$ high quality cables (x4)	—	—	<p>1 foot maximum length</p> <p>Matching length <math>\leq</math> <math>\pm</math> 1 ps at 200 MHz</p>

## Test Conditions

The following setup and environmental conditions are required to ensure the PXle-5451 meets published specifications.

- Keep connections to the device short. Long cables and wires act as antennas, picking up noise that can affect measurements.
- Keep the device outputs balanced at all times during measurements.
- Keep relative humidity between 10% and 90% noncondensing.
- Maintain a temperature between 18 °C and 28 °C.

- Allow a warm-up time of at least 30 minutes after powering on all hardware, loading the operating system, and, if necessary, enabling the device. Unless manually disabled, the NI-FGEN driver automatically loads with the operating system and enables the device. The warm-up time brings the measurement circuitry of the device to a stable operating temperature.
- Perform self-calibration on the device. Do not perform self-calibration until the device has completed the 30-minute warm up.
- Ensure that the PXI Express chassis fan speed is set to HI, that the fan filters, if included, are clean, and that the empty slots contain filler panels.
- Plug the PXI Express chassis and the calibrator into the same power strip to avoid ground loops.

## Device Setup

1. Install the module in the PXI Express chassis according to the instructions in the NI Signal Generators Getting Started Guide.
2. Configure the hardware using Measurement & Automation Explorer (MAX).
3. Launch the Calibration Executive procedure and complete the setup wizard.

## Test Limit Equations

**Table 312.** PXIe-5451 Test Limit Equations

Equation Type	Equation
Verifying DC Voltage Amplitude Absolute Accuracy	$\text{Accuracy} = (\text{Differential Output Range} \times \text{Gain Error \%}) + \text{Gain Error Path:}$ <ul style="list-style-type: none"> <li>• Single-Ended Main               <ul style="list-style-type: none"> <li>◦ Gain Error (% of Output Range): 0.4%</li> <li>◦ Gain Error (V): 0.0005</li> </ul> </li> <li>• Differential Main               <ul style="list-style-type: none"> <li>◦ Gain Error (% of Output Range): 0.6%</li> <li>◦ Gain Error (V): 0.001</li> </ul> </li> <li>• Differential Direct               <ul style="list-style-type: none"> <li>◦ Gain Error (% of Output Range): 0.2%</li> <li>◦ Gain Error (V): 0</li> </ul> </li> </ul>
Verifying DC Voltage Offset Accuracy	$\text{Accuracy} = (\text{Differential Output Range} \times \text{Gain Error \%}) + (\text{Differential Offset} \times \text{Offset Error \%}) + \text{Offset Error Path:}$

Equation Type	Equation
	<ul style="list-style-type: none"> <li>• Single-Ended Main               <ul style="list-style-type: none"> <li>◦ Gain Error (% of Output Range): 0.04%</li> <li>◦ Offset Error (% of Output Range): 0.15%</li> <li>◦ Offset Error (V): 0.00125</li> </ul> </li> <li>• Differential Main               <ul style="list-style-type: none"> <li>◦ Gain Error (% of Output Range): 0.01%</li> <li>◦ Offset Error (% of Output Range): 0.30%</li> <li>◦ Offset Error (V): 0.00200</li> </ul> </li> <li>• Differential Direct               <ul style="list-style-type: none"> <li>◦ Gain Error (% of Output Range): 0%</li> <li>◦ Offset Error (% of Output Range): 0%</li> <li>◦ Offset Error (V): 0.00100</li> </ul> </li> </ul>
Verifying DC Voltage Common Mode Offset Accuracy	<p>Accuracy = (Common Mode Offset × % of Offset) + Offset Error Path:</p> <ul style="list-style-type: none"> <li>• Differential Main               <ul style="list-style-type: none"> <li>◦ % of Offset (%): 0.3%</li> <li>◦ Gain Error (V): 0.00200</li> </ul> </li> <li>• Differential Direct               <ul style="list-style-type: none"> <li>◦ % of Offset (%): 0%</li> <li>◦ Gain Error (V): 0.00035</li> </ul> </li> </ul>
Verifying DC Voltage Channel-to-Channel Relative Accuracy	<p>Accuracy = (Differential Output Range (V) × Error %) + Error Offset</p> <ul style="list-style-type: none"> <li>• Differential Main               <ul style="list-style-type: none"> <li>◦ Error (% of Output Range): 0.66%</li> <li>◦ Error Offset(<math>V_{pk-pk}</math>): 0.00175</li> </ul> </li> <li>• Differential Direct               <ul style="list-style-type: none"> <li>◦ Error (% of Output Range): 0.08%</li> <li>◦ Error Offset(<math>V_{pk-pk}</math>): 0</li> </ul> </li> </ul>
Verifying AC Voltage Amplitude Absolute Accuracy	<p>Accuracy = (Differential Output Range (V) × Error %) + Error Offset Path:</p> <ul style="list-style-type: none"> <li>• Single-Ended Main               <ul style="list-style-type: none"> <li>◦ Error (% of Output Range): 0.8%</li> <li>◦ Error Offset (<math>V_{rms}</math>): 0.0010</li> </ul> </li> <li>• Differential Main</li> </ul>



Equation Type	Equation
	<ul style="list-style-type: none"> <li>◦ Error (% of Output Range): 0.8%</li> <li>◦ Error Offset (<math>V_{rms}</math>): 0.0015</li> <li>• Differential Direct               <ul style="list-style-type: none"> <li>◦ Error (% of Output Range): 0.5%</li> <li>◦ Error Offset (<math>V_{rms}</math>): 0</li> </ul> </li> </ul>
Verifying Differential Direct Path AC Voltage Amplitude Channel-to-Channel Relative Accuracy	<p>Accuracy = Differential Output Range (V) × Error %</p> <ul style="list-style-type: none"> <li>• Error % = 0.2%</li> <li>• Differential Output Range = 2 V</li> </ul>
Verifying Channel-to-Channel Timing Alignment Accuracy	$\epsilon = V_{DMM} - V_{Expected}$
Verifying Frequency Response (Flatness)	<p>Path:</p> <ul style="list-style-type: none"> <li>• Single-Ended Main               <math display="block">Flatness_{Ref} = 10 \times \log \left[ \frac{W_{f(+)}}{W_{Ref(+)}} \right]</math> </li> <li>• Differential Main               <math display="block">Flatness_{Ref} = 10 \times \log \left[ \frac{W_{f(+)} + W_{f(-)} + 2 \times \sqrt{W_{f(+)} \times W_{f(-)}}}{W_{Ref(+)} + W_{Ref(-)} + 2 \times \sqrt{W_{Ref(+)} \times W_{Ref(-)}}} \right]</math> </li> </ul>
Verifying Average Noise Density	$\epsilon_{0,1} = V_{Ch0} - V_{Ch1}$
Verifying Internal Reference Clock Frequency Accuracy	$\epsilon = \frac{f_{meas} - 10M}{10M} \times 100$

### Related concepts:

- [Launching a Calibration Procedure](#)

## PXI Chassis Calibration Procedures

Calibrate your PXI chassis with Calibration Executive.

## PXIe-1092 Calibration Procedure

Calibrate the PXIe-1092 with Timing and Synchronization option using Calibration Executive.

### Calibration Executive Procedure Features

Verify Only ✓	Verify & Adjust ✓	Manual Mode ✓	Optional Adjust ✗
---------------	-------------------	---------------	-------------------

### Approximate Test Time

Warmup	Verify Only	Verify & Adjust
24 hours	2.5 minutes	5 minutes

### Test Equipment

The following table lists the test equipment required for calibrating the PXIe-1092 with Timing and Synchronization option.

**Table 312.** Test equipment for calibrating the PXIe-1092 with Timing and Synchronization option

Instrument	Recommended Model	Requirements
Frequency reference	Symmetricon 8040C	Output Frequency: 10 MHz Accuracy: $\leq 1 \times 10^{-10}$
Frequency counter	Keysight Technologies 53220A or Keysight/Agilent 53131A	Frequency Range: > 10 MHz Frequency Resolution: $\leq 0.001$ Hz at 10 MHz
BNC (m)-to-BNC (m) cable	—	—
BNC (f)-to-SMA (m) cable	—	—

## Test Conditions

The following setup and environmental conditions are required to ensure the PXIe-1092 meets published specifications.

- Keep cabling wire as short as possible. Long cables and wires act as antennas, picking up extra noise that can affect measurement.
- Verify that all connections, including front panel connections and screws, are secure.
- Maintain an ambient temperature of  $23\text{ }^{\circ}\text{C} \pm 5\text{ }^{\circ}\text{C}$ .
- Keep relative humidity below 80%, non-condensing.
- Ensure that the PXIe-1092 chassis has been powered on continuously for at least 24 hours prior to calibration to allow the 10 MHz oscillator frequency to stabilize.
- Ensure that the Frequency Reference has been powered on continuously as specified in its user documentation to meet the minimum requirements for frequency range and resolution noted in .

## Device Setup

1. Connect the PXIe-1092 chassis to your system using an appropriate MXI-Express or Thunderbolt cable.
2. Configure the hardware using Measurement & Automation Explorer (MAX).
3. Launch the Calibration Executive procedure and complete the setup wizard.

## Test Limit Equations

1 year limits are calculated as follows:

$$\text{TestLimit} = \text{TestValue} \pm (\text{TestValue} \cdot \text{Accuracy})$$

### Related concepts:

- [Launching a Calibration Procedure](#)

## PXIe-1095 Calibration Procedure

Calibrate the PXIe-1095 with Timing and Synchronization option using Calibration Executive.

## Calibration Executive Procedure Features

Verify Only ✓	Verify & Adjust ✓	Manual Mode ✓	Optional Adjust ⓧ
---------------	-------------------	---------------	-------------------

## Approximate Test Time

Warmup	Verify Only	Verify & Adjust
24 hours	2.5 minutes	5 minutes

## Test Equipment

The following table lists the test equipment required for calibrating the PXIe-1095 with Timing and Synchronization option.

**Table 312.** Test equipment for calibrating the PXIe-1095 with Timing and Synchronization option

Instrument	Recommended Model	Requirements
Frequency reference	Symmetricon 8040C	Output Frequency: 10 MHz Accuracy: $\leq 1 \times 10^{-10}$
Frequency counter	Keysight Technologies 53220A or Keysight/ Agilent 53131A	Frequency Range: > 10 MHz Frequency Resolution: $\leq$ 0.001 Hz at 10 MHz
BNC (m)-to-BNC (m) cable	—	—
BNC (f)-to-SMA (m) cable	—	—

## Test Conditions

The following setup and environmental conditions are required to ensure the PXIe-1095 meets published specifications.

- Keep cabling wire as short as possible. Long cables and wires act as antennas,

picking up extra noise that can affect measurement.

- Verify that all connections, including front panel connections and screws, are secure.
- Maintain an ambient temperature of  $23\text{ }^{\circ}\text{C} \pm 5\text{ }^{\circ}\text{C}$ .
- Keep relative humidity below 80%, non-condensing.
- Ensure that the PXIe-1095 chassis has been powered on continuously for at least 24 hours prior to calibration to allow the 10 MHz oscillator frequency to stabilize.
- Ensure that the Frequency Reference has been powered on continuously as specified in its user documentation to meet the minimum requirements for frequency range and resolution noted in .

## Device Setup

1. Connect the PXIe-1095 chassis to your system using an appropriate MXI-Express or Thunderbolt cable.
2. Configure the hardware using Measurement & Automation Explorer (MAX).
3. Launch the Calibration Executive procedure and complete the setup wizard.

## Test Limit Equations

1 year limits are calculated as follows:

$$\text{TestLimit} = \text{TestValue} \pm (\text{TestValue} \cdot \text{Accuracy})$$

## Related concepts:

- [Launching a Calibration Procedure](#)

# Semiconductor Test System Calibration Procedures

Calibrate your Semiconductor Test System (STS) with Calibration Executive.

## STS-DIO-01 Timing CLB Calibration Procedure

Calibrate the STS-DIO-01 Timing Calibration Load Board (CLB) using Calibration Executive.

## Calibration Executive Procedure Features

Verify Only ✓	Verify & Adjust ✓	Manual Mode ✗	Optional Adjust ✗
---------------	-------------------	---------------	-------------------

## Approximate Test Time

<b>Verify Only</b>	<b>Verify &amp; Adjust</b>
35 minutes	70 minutes

## Test Equipment

The following table lists the test equipment required to calibrate the STS-DIO-01 Timing CLB.

**Table 308.** Test equipment for calibrating the STS-DIO-01 Timing CLB

Instrument	Recommended Model	Where Used	Requirements
Oscilloscope with TDR Module	Tektronix DSA8300 and Tektronix 80E04	Cable Characterization Relative Signal Path Skew Verification Relative Signal Path Skew Adjustment	Bandwidth: >20 MHz Absolute Accuracy: <17.5 ps Relative Accuracy: <3 ps
External reference timebase	PXIe-6674T or Rubidium Symmetricom 8400	Cable Characterization Relative Signal Path Skew Verification Relative Signal Path Skew Adjustment	10 MHz Reference: <0.1 $\mu\text{Hz}/\text{Hz}$
2.92 mm cable	Maury Microwave Stability Plus Cable SP-292-MM-24	Cable Characterization	Length: <24 in Velocity of Prop:

Instrument	Recommended Model	Where Used	Requirements
		Relative Signal Path Skew Verification Relative Signal Path Skew Adjustment	>70% Attenuation: <0.15 dB @ 1 GHz
STS T1 M2	NI P/N 866286-01	Relative Signal Path Skew Verification Relative Signal Path Skew Adjustment	—
BNC-to-2.92 mm adapter	—	Cable Characterization Relative Signal Path Skew Verification Relative Signal Path Skew Adjustment	—
Air source	—	Relative Signal Path Skew Verification Relative Signal Path Skew Adjustment	90–100 psi
5/16-inch torque wrench for 2.92 mm connections	—	Cable Characterization Relative Signal Path Skew Verification Relative Signal Path Skew Adjustment	8 in-lbs ± 0.5 in-lbs
Calibration Executive controller	—	—	Dedicated Ethernet port

Instrument	Recommended Model	Where Used	Requirements
			Configured as described

## Test Conditions

The following setup and environmental conditions are required to ensure the STS-DIO-01 Timing CLB meets published specifications.

- Keep cabling as short as possible. Long cables and wires act as antennas, picking up extra noise that can affect measurements.
- Use shielded copper wire for all cable connections to the DUT. Use twisted-pair wire to eliminate noise and thermal offsets.
- Verify that all connections, including front panel connections and screws, are secure.
- Maintain an ambient temperature of  $23\text{ }^{\circ}\text{C} \pm 5\text{ }^{\circ}\text{C}$ .
- Keep relative humidity below 80%, non-condensing.
- Allow a warm-up time of at least 30 minutes after the DUT is connected to the STS T1M2 frame and powered on. The warm-up time ensures that measurement circuitry is at a stable operating temperature.
- Ensure that the PXI chassis fan speed is set to HIGH, that the fan filters are clean, and that the empty slots contain filler panels. For more information, refer to the ***Maintain Forced-Air Cooling Note to Users*** document available at [ni.com/docs](http://ni.com/docs).

## First Time Setup

The STS and the Calibration Executive controller must be configured to communicate directly over an Ethernet connection.

## STS System

Follow the instructions to configure the system for autologin and static IP.

1. Disconnect the Ethernet connection between the STS and the Calibration Executive controller.



2. Use a USB flash drive to copy the following to the STS: C:\Program Files\National Instruments\Calibration Executive\UserResources\STS Timing CLB\Test Fixture
3. On the STS, right-click TimingCLBFixture.bat and select **Run as administrator**.
4. Accept UAC Permissions to launch as administrator.
5. When prompted, enter the user name and password for the current login. This will

configure autologin.

```

C:\WINDOWS\System32\cmd.exe

=====
Running Admin shell
=====
1 file(s) copied.
1 file(s) copied.
Enter the local user ID: username
Enter the Password:
    
```

6. When prompted, connect the Ethernet cable between the CalExec controller and

the STS, and press a key.

```

C:\WINDOWS\System32\cmd.exe

=====
Running Admin shell
=====
1 file(s) copied.
1 file(s) copied.
Enter the local user ID:
Enter the Password:
connected devices found:
Ethernet
Ethernet 2
connect the STS Fixture into the Cal-exec ethernet port
Press any key to continue . . .
    
```

7. Once the new connection is detected, the connection will be displayed.
8. Once the IP address is set, close the command window. The batch file sets the STS

IP address to 10.0.20.30.

```

Administrator: C:\WINDOWS\System32\cmd.exe

=====
Running Admin shell
=====
1 file(s) copied.
1 file(s) copied.
Enter the local user ID:
Enter the Password:
connected devices found:
Ethernet
Ethernet 2
New connection found
Ethernet
will be set to static IP press ctrl+C to cancel
Press any key to continue . . .
IP address set
    
```

## Calibration Executive Controller

Follow the instructions to set the Ethernet port to static IP.

1. Disconnect the Ethernet connection between the STS and the Calibration Executive controller.
2. On the CalExec system, execute the following script, accepting elevated permissions:  
`C:\Program Files\National Instruments\Calibration Executive\UserResources\STS Timing CLB\CalExec System\CalExecSystemOneTimeSetup.bat`
3. When prompted, connect the STS to the CalExec Ethernet port and press a key to

continue.

```

C:\WINDOWS\System32\cmd.exe
=====
Running Admin shell
=====
connected devices found:
Ethernet 2
connect the STS Fixture into the Cal-exec ethernet port
Press any key to continue . . .

```

4. When prompted, press any key to accept static IP, and then close the command window. The script sets the return IP address for the Calibration Executive

controller to 10.10.0.20.5.

```

C:\WINDOWS\System32\cmd.exe
=====
Running Admin shell
=====
connected devices found:
Ethernet 2
connect the STS Fixture into the Cal-exec ethernet port
Press any key to continue . . .
connected devices found:
Ethernet 2
New connection found
Ethernet
will be set to static IP press ctrl+C to cancel
Press any key to continue . . .

```

## Device Setup

1. Connect the 10 MHz clk reference from the timebase to the back of the oscilloscope.
2. Connect the TDR module to the first block on the front of the oscilloscope.
3. Power on the STS system.
4. Check that air is connected to the STS. Follow "Air Setup Requirements" in the **STS**

**Site Preparation and Bring Up Manual.** If necessary, contact NI support to obtain a copy of the **STS Site Preparation and Bring Up Manual** (P/N 377702x-01).

- a. Install STS-DIO-01 Timing CLB on the top of the STS, respecting proper orientation.
  - b. There are two buttons on either side of the front of the STS, approximately two arm-lengths apart, and located towards the top. Press the two buttons simultaneously. You should hear and see the STS-DIO-01 device interface board (DIB) lock with air.
5. Connect the STS-DIO-01 Timing CLB to your system using an Ethernet cable.
  6. Launch the Calibration Executive procedure and complete the setup wizard.
  7. Connect CH 0 of the TDR module to the channel on the STS Timing CLB that is prompted by Calibration Executive.

**Figure 1.** STS-DIO-01 Timing CLB Initial Test Connections

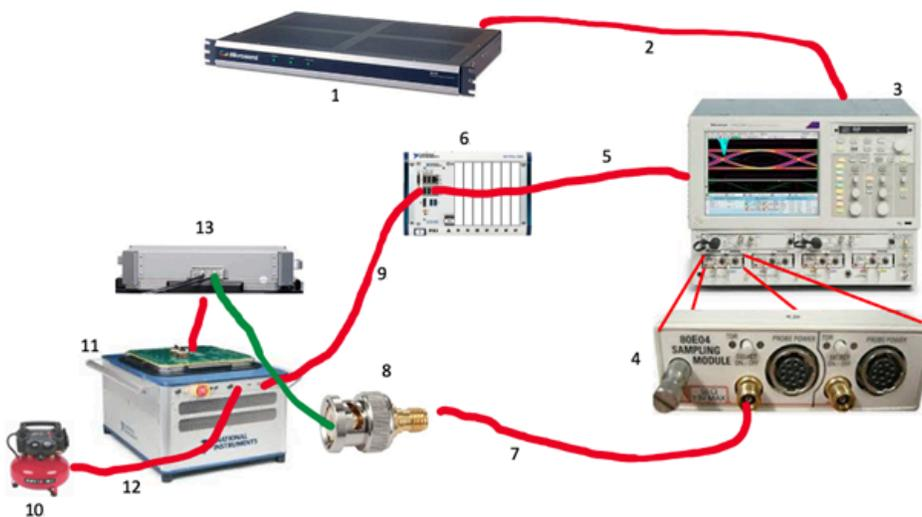

1. External reference timebase
2. BNC-to-BNC cable
3. Oscilloscope (Tektronix DSA8300)
4. TDR Module (Tektronix 80E04)
5. GPIB cable
6. Calibration Executive controller
7. 2.92 mm cable
8. BNC-to-2.92 mm adapter
9. Ethernet cable

10. Air source
11. Semiconductor Test System (STS)
12. Airhose cable
13. DUT

## Test Limit Equations

**Table 309.** STS-DIO-01 Timing CLB Test Limit Equations

Equation Type	Equation
Absolute Signal Path Delay Functional Test	Test Limits = Nominal $\pm$ 500 ps
Relative Signal Path Skew	Test Limits = 0 ps to 30 ps
Reference Path Repeatability	Test Limits = $\pm$ 3 ps

## Related concepts:

- [Launching a Calibration Procedure](#)

# TestScale Module Calibration Procedures

Calibrate your TestScale modules with Calibration Executive.

## TS-15000/15010 Calibration Procedure

Calibrate the TS-15000 or TS-15010 using Calibration Executive.

## Calibration Executive Procedure Features

Verify Only ✓	Adjust Only ✗	Verify & Adjust ✗	Manual Mode ✗	Optional Adjust ✗
---------------	---------------	-------------------	---------------	-------------------

## Approximate Test Time

Warm-up	Verify Only
10 minutes	2 minutes

## Test Equipment

The following table lists the test equipment required for calibrating the TS-15000/15010.

**Table 312.** Test equipment for calibrating the TS-15000/15010

Instrument	Recommended Model	Where Used	Functional Requirements
Counter	Keysight 53220A	All tests	Counter input
TestScale Core Module (the module used with the backplane under test)	TS-15050	All tests	—
37-Pin DSUB Terminal Block	NI-9923	All tests	—
37-Pin DSUB to 37-Pin DSUB cable	NI 778621-01	All tests	—
BNC to leads cable	Pomona Electronic 4970	All tests	—

## Test Conditions

The following setup and environmental conditions are required to ensure the TS-15000/15010 meets published specifications.

- Keep connections to the device as short as possible. Long cables and wires act as antennas, picking up extra noise that can affect measurements.
- Verify that all connections to the device are secure.
- Allow a warm-up time for all of the instruments and equipment according to the manufacturer instructions.
- Use shielded copper wire for all cable connections to the device.

## Device Setup

1. Install the hardware as described in ***TestScale Features***.
2. Configure the hardware using Measurement & Automation Explorer (MAX).
3. Launch the Calibration Executive procedure. Calibration Executive guides you through the required connections.



**Note** There is no adjustment procedure for the TS-15000/15010. If the TS-15000/15010 verification does not fall within the desired specifications, ensure that the test conditions have been met before returning to NI for repair.

## Test Limit Equations

The test limits are derived from the ***TS-15000/15010 Calibration Procedure***. Refer to the ***TS-15000/15010 Calibration Procedure*** for the accuracy under calibration conditions, and formulas used to determine the limits.

### Related information:

- [TestScale Features](#)

## TS-15100 Calibration Procedure

Calibrate the TS-15100 using Calibration Executive.

### Calibration Executive Procedure Features

Verify Only ✓	Adjust Only ✓	Verify & Adjust ✓	Manual Mode ✗	Optional Adjust ✓
---------------	---------------	-------------------	---------------	-------------------

### Approximate Test Time

Warm-up	Verify Only	Adjust Only	Verify & Adjust
10 minutes	4 minutes	2 minutes	6 minutes

### Test Equipment

The following table lists the test equipment required for calibrating TS-15100.

**Table 312.** Test equipment for calibrating the TS-15100

Instrument	Recommended Model	Where Used	Functional Requirements
Calibrator	Fluke 5730A	All tests	<ul style="list-style-type: none"> <li>• DC voltage output</li> <li>• Voltage range: up to 10 V</li> </ul>
TestScale Backplane and Core Module Calibration Kit	NI 788650-02	All tests	—
37-Pin DSUB Terminal Block	NI-9923	All tests	—
37-Pin DSUB to 37-Pin DSUB cable	NI 778621-01	All tests	—
Banana Plugs (x2)	Multicomp Pro PE000038 (Red)  Multicomp Pro PE000037 (Black)	All tests	—
Twisted-pair wire	—	—	—

## Test Conditions

The following setup and environmental conditions are required to ensure the TS-15100 meets published specifications.

- Keep connections to the device as short as possible. Long cables and wires act as antennas, picking up extra noise that can affect measurements.
- Verify that all connections to the device are secure.
- Allow a warm-up time for all of the instruments and equipment according to the manufacturer instructions.
- Use shielded copper wire for all cable connections to the device.
- Use twisted-pair wire to eliminate noise and thermal offsets.

# Connecting the Hardware

Figure 1. Functional Test Connections for the TS-15100

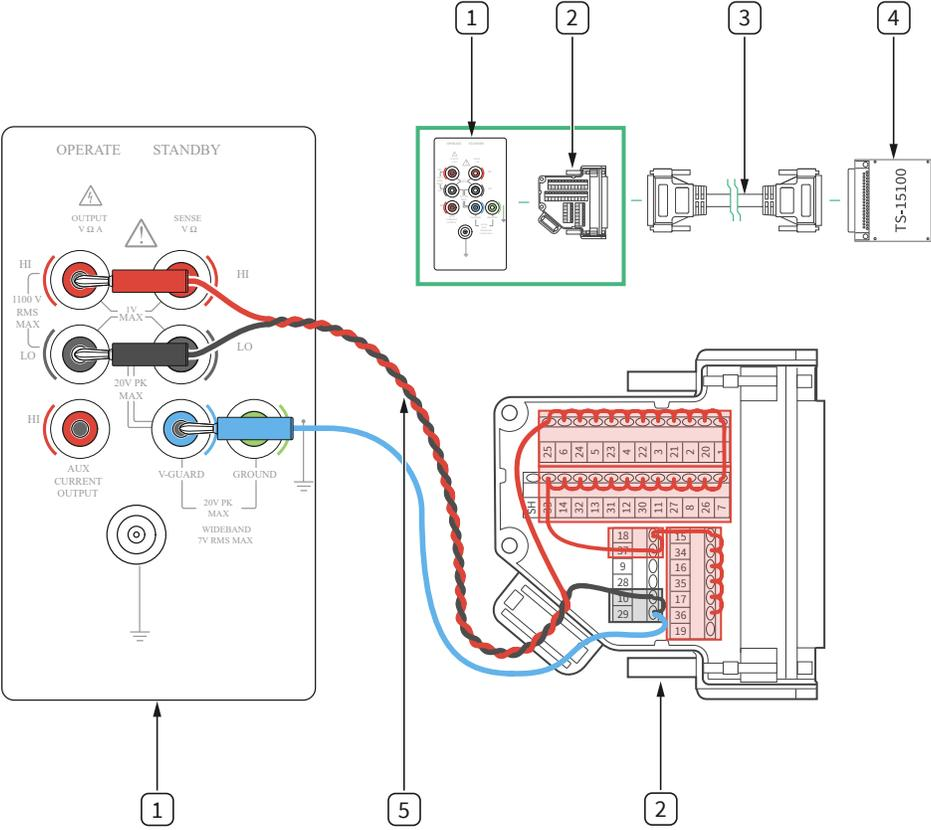

- 1. Calibrator
- 2. NI 9923
- 3. 37-pin DSUB to 37-pin DSUB cable
- 4. TS-15100
- 5. Twisted-pair wire

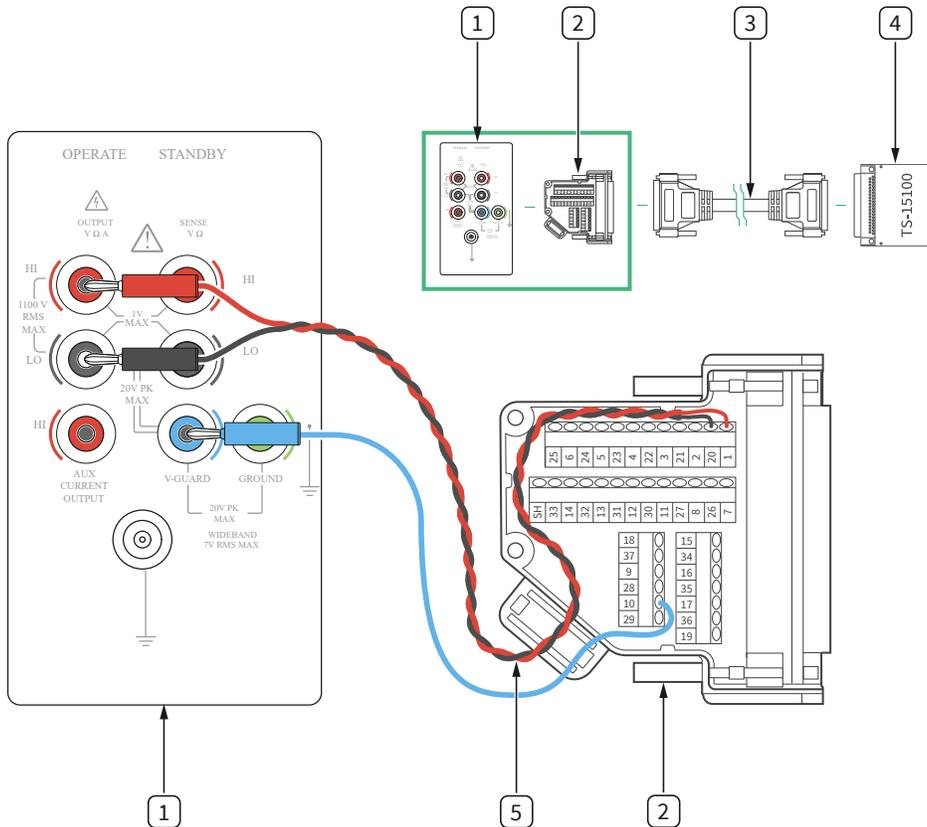

**Figure 1.** Verification and Adjust Test Connections for the TS-15100

1. Calibrator
2. NI 9923
3. 37-pin DSUB to 37-pin DSUB cable
4. TS-15100
5. Twisted-pair wire

### Device Setup

1. Install the hardware as described in the ***TS-15100 Feature Guide***.
2. Based on the type of test you want to perform, connect the hardware as shown in the ***Connecting the Hardware*** section of this procedure.
3. Configure the hardware using Measurement & Automation Explorer (MAX).
4. Launch the Calibration Executive procedure. Calibration Executive guides you through the required connections.

### Test Limit Equations

The test limits are derived from the ***TS-15100 Calibration Procedure***. Refer to the

**TS-15100 Calibration Procedure** for the accuracy under calibration conditions, and formulas used to determine the limits.

### Related information:

- [TS-15100 Calibration Procedure](#)

## TS-15110 Calibration Procedure

Calibrate the TS-15110 using Calibration Executive.

### Calibration Executive Procedure Features

Verify Only ✓	Adjust Only ✓	Verify & Adjust ✓	Manual Mode ✗	Optional Adjust ✓
---------------	---------------	-------------------	---------------	-------------------

### Approximate Test Time

Warm-up	Verify Only	Adjust Only	Verify & Adjust
10 minutes	3 minutes	5 minutes	11 minutes

### Test Equipment

The following table lists the test equipment required for calibrating TS-15110.

**Table 312.** Test equipment for calibrating the TS-15110

Instrument	Recommended Model	Where Used	Functional Requirements
Digital multimeter (DMM)	PXIe-4081	All tests	<ul style="list-style-type: none"> <li>• DC voltage output</li> <li>• Voltage range: up to 10 V</li> </ul>
TestScale Backplane and Core Module Calibration Kit	NI 788650-02	All tests	—
37-Pin DSUB Terminal Block	NI-9923	All tests	—

Instrument	Recommended Model	Where Used	Functional Requirements
37-Pin DSUB to 37-Pin DSUB cable	NI 778621-01	All tests	—
Banana Plugs (x2)	Multicomp Pro PE000038 (Red)  Multicomp Pro PE000037 (Black)	All tests	—
Twisted-pair wire	—	—	—

## Test Conditions

The following setup and environmental conditions are required to ensure the TS-15110 meets published specifications.

- Keep connections to the device as short as possible. Long cables and wires act as antennas, picking up extra noise that can affect measurements.
- Verify that all connections to the device are secure.
- Allow a warm-up time for all of the instruments and equipment according to the manufacturer instructions.
- Use shielded copper wire for all cable connections to the device.
- Use twisted-pair wire to eliminate noise and thermal offsets.

## Device Setup

1. Install the hardware as described in the ***TS-15110 Feature Guide***.
2. Configure the hardware using Measurement & Automation Explorer (MAX).
3. Launch the Calibration Executive procedure. Calibration Executive guides you through the required connections.

## Test Limit Equations

The test limits are derived from the ***TS-15110 Calibration Procedure***. Refer to the ***TS-15110 Calibration Procedure*** for the accuracy under calibration conditions, and formulas used to determine the limits.

**Related information:**

- [TS-15110 Calibration Procedure](#)

## DMM Instrument Standard Considerations

The PXI-4070/4071/4072 digital multimeter (DMM) is a recommended instrument standard for the following devices. Do not substitute the PXIe-4080/4081/4082 as DMM to calibrate these devices; doing so can cause the Calibration Executive procedure to produce errors or terminate.

- USB-5132/5133
- NI 5402/5406
- NI 5412/5421/5441
- PXIe-5645R
- NI 6731/6733
- NI 6711/6713
- NI 6722/6723
- NI 9218
- NI 9219
- NI 9260
- NI 9269

**Related concepts:**

- [USB-5132/5133 Calibration Procedure](#)
- [NI 5402/5406 Calibration Procedure](#)
- [NI 5412/5421/5422/5441/5442 Calibration Procedure](#)
- [PXIe-5645R Calibration Procedure](#)
- [NI 671x/672x/673x Calibration Procedure](#)
- [NI 9218 Calibration Procedure](#)
- [NI 9219 Calibration Procedure](#)
- [NI 9260 Calibration Procedure](#)
- [NI 9269 Calibration Procedure](#)