

## COMPREHENSIVE SERVICES

We offer competitive repair and calibration services, as well as easily accessible documentation and free downloadable resources.

## SELL YOUR SURPLUS

We buy new, used, decommissioned, and surplus parts from every NI series. We work out the best solution to suit your individual needs.

 Sell For Cash    Get Credit    Receive a Trade-In Deal

## OBSOLETE NI HARDWARE IN STOCK & READY TO SHIP

We stock **New**, **New Surplus**, **Refurbished**, and **Reconditioned** NI Hardware.



*Bridging the gap between the manufacturer and your legacy test system.*

 1-800-915-6216

 [www.apexwaves.com](http://www.apexwaves.com)

 [sales@apexwaves.com](mailto:sales@apexwaves.com)

*All trademarks, brands, and brand names are the property of their respective owners.*

**Request a Quote**

 **CLICK HERE**

**TB-2631**

# INSTALLATION INSTRUCTIONS

# NI TB-2631

## Terminal Block for the NI PXI-2530

このドキュメントには、日本語ページも含まれています。

This guide describes how to install and connect signals to the National Instruments TB-2631 terminal block to configure the PXI-2530 as a:

- 4x32 1-wire matrix
- 4x16 2-wire matrix

Refer to the *NI Switches Getting Started Guide* to determine when to install the terminal block.

## Introduction

---

The TB-2631 terminal block installs in front of the PXI-2530 switch module. The TB-2631 has screw terminals to connect signals to the switch. Screw terminals for the trigger input and trigger output signals also are available.

## Conventions

---

The following conventions are used in this guide:

»

The » symbol leads you through nested menu items and dialog box options to a final action. The sequence **File»Page Setup»Options** directs you to pull down the **File** menu, select the **Page Setup** item, and select **Options** from the last dialog box.



This icon denotes a note, which alerts you to important information.



This icon denotes a caution, which advises you of precautions to take to avoid injury, data loss, or a system crash.

<b>bold</b>	Bold text denotes items that you must select or click in the software, such as menu items and dialog box options. Bold text also denotes parameter names.
<i>italic</i>	Italic text denotes variables, emphasis, a cross reference, or an introduction to a key concept. This font also denotes text that is a placeholder for a word or value that you must supply.
monospace	Text in this font denotes text or characters that you should enter from the keyboard, sections of code, programming examples, and syntax examples. This font is also used for the proper names of disk drives, paths, directories, programs, subprograms, subroutines, device names, functions, operations, variables, filenames and extensions, and code excerpts.

## 1. Unpack the Terminal Block

---

To avoid damage when you handle the terminal block, take the following precautions:



**Caution** *Never* touch the exposed pins of connectors.

- Ground yourself using a grounding strap or by touching a grounded object.
- Touch the antistatic package to a metal part of the chassis before you remove the terminal block from the package.

Remove the terminal block from the package and inspect the terminal block for loose components or any sign of damage. Notify NI if the terminal block appears damaged in any way. Do *not* install a damaged terminal block on a switch module.

Store the terminal block in the antistatic package when not in use.

## 2. Verify the Components

---

Make sure you have the following:

- TB-2631 terminal block
- PXI chassis
- PXI-2530 switch module
- 1/8 inch flathead screwdriver

# 3. Connect Signals

---

To connect signals to the terminal block, complete the following steps:

1. Remove the terminal block top cover screws with a flathead screwdriver.
2. Gently lift the terminal block top cover off the terminal block.
3. Loosen the two screws on the strain-relief bar, leaving plenty of space for the signal cables.
4. Prepare the signal cable by stripping the insulation no more than 3/16 of an inch.
5. Pull the signal cables through the strain-relief opening shown in Figure 1.
6. Connect the cables to the terminals by inserting the stripped end of the cable into the terminal. Secure the connection by tightening the screw for each terminal. When connecting the signals, refer to the connection diagram in Figure 2.



**Note** When connecting signals to the TB-2631, refer to Tables 1 and 2 to determine where to connect signals for the chosen topology.

7. Tighten the two screws on the strain-relief bar, securing the signal cables.
8. Replace the terminal block top cover to the terminal block.
9. Secure the terminal block top cover with the top cover screws.

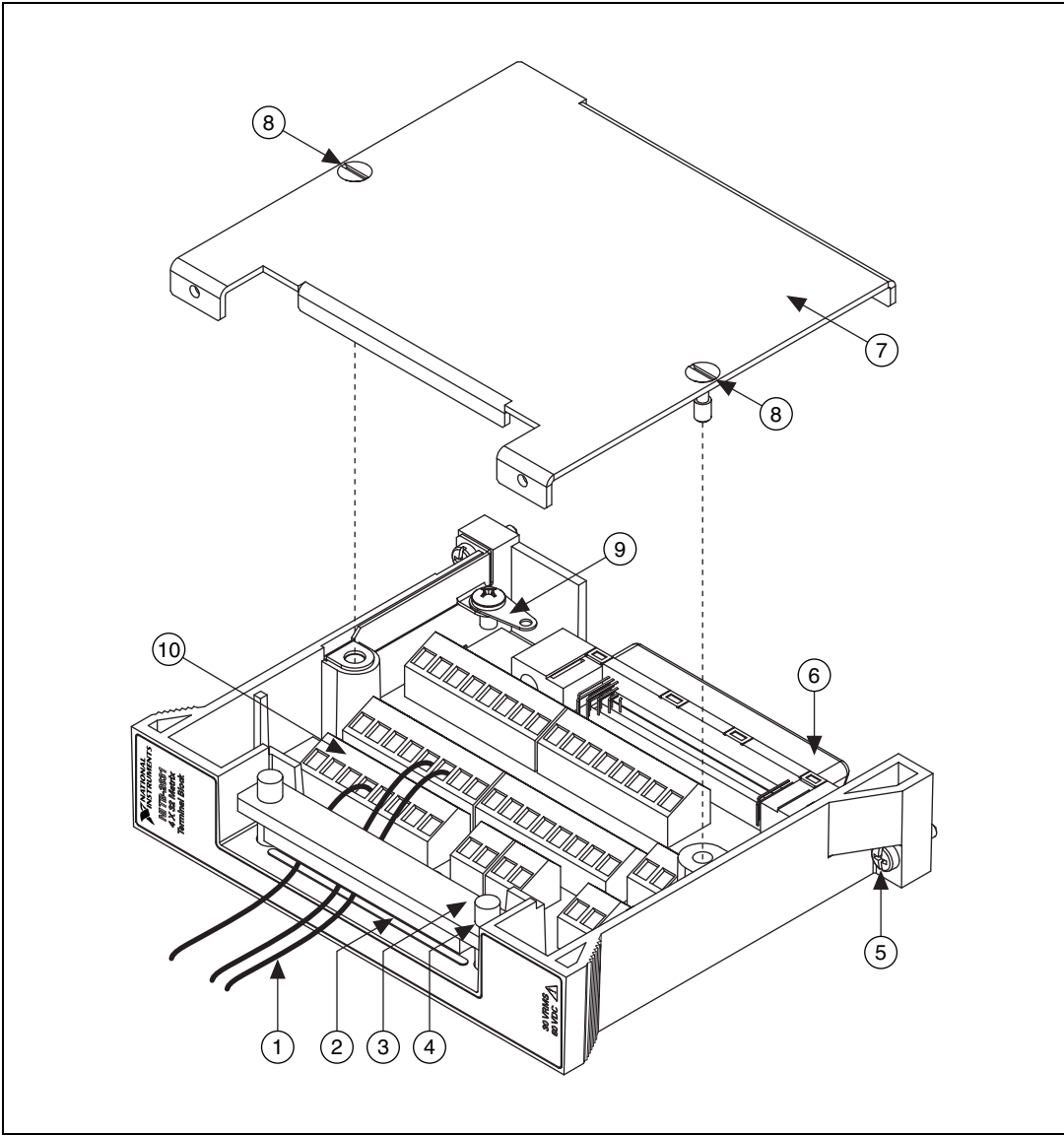

- |   |                       |    |                          |
|---|-----------------------|----|--------------------------|
| 1 | Signal Cables         | 6  | Rear Connector           |
| 2 | Strain-Relief Opening | 7  | Terminal Block Top Cover |
| 3 | Strain-Relief Bar     | 8  | Top Cover Screws         |
| 4 | Strain-Relief Screw   | 9  | Safety Ground Lug        |
| 5 | Chassis Screws        | 10 | Screw Terminals          |

**Figure 1.** TB-2631 Terminal Block

NI TB-2631 Screw Terminal Reference

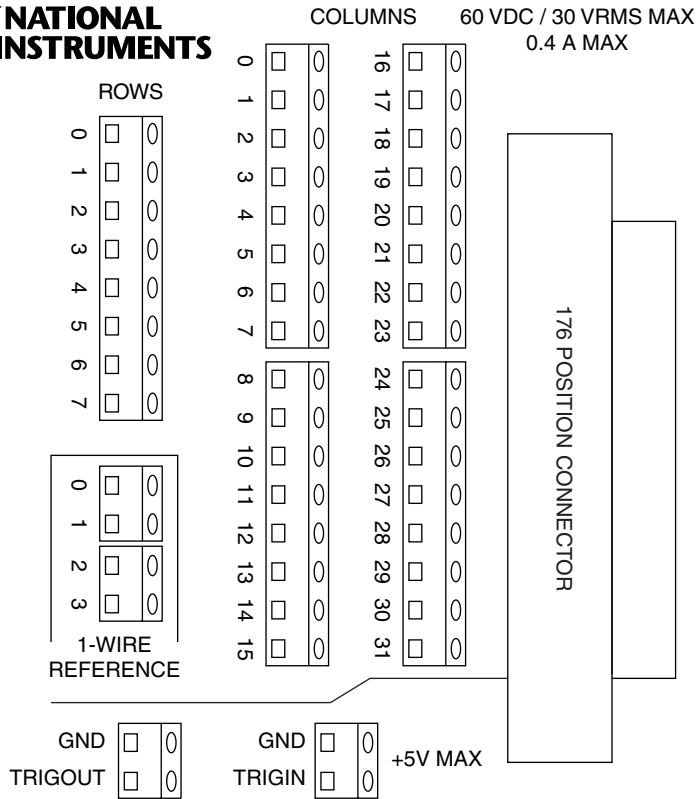

**Figure 2.** TB-2631 Terminal Reference

**Table 1.** 4x32, 1-Wire Topology Terminal Mapping

<b>Software Name</b>	<b>Hardware Name</b>
r0	ROW 0
r1	ROW 2
r2	ROW 4
r3	ROW 6
c0	COLUMN 0
c1	COLUMN 1
c2	COLUMN 2
c3	COLUMN 3
c4	COLUMN 4
c5	COLUMN 5
c6	COLUMN 6
c7	COLUMN 7
c8	COLUMN 8
c9	COLUMN 9
c10	COLUMN 10
c11	COLUMN 11
c12	COLUMN 12
c13	COLUMN 13

<b>Software Name</b>	<b>Hardware Name</b>
c14	COLUMN 14
c15	COLUMN 15
c16	COLUMN 16
c17	COLUMN 17
c18	COLUMN 18
c19	COLUMN 19
c20	COLUMN 20
c21	COLUMN 21
c22	COLUMN 22
c23	COLUMN 23
c24	COLUMN 24
c25	COLUMN 25
c26	COLUMN 26
c27	COLUMN 27
c28	COLUMN 28
c29	COLUMN 29
c30	COLUMN 30
c31	COLUMN 31

**Table 2.** 4x16, 2-Wire Topology Terminal Mapping

Software Name	Hardware Name	
	+	-
r0	ROW 0	ROW 1
r1	ROW 2	ROW 3
r2	ROW 4	ROW 5
r3	ROW 6	ROW 7
c0	COLUMN 0	COLUMN 16
c1	COLUMN 1	COLUMN 17
c2	COLUMN 2	COLUMN 18
c3	COLUMN 3	COLUMN 19
c4	COLUMN 4	COLUMN 20
c5	COLUMN 5	COLUMN 21

Software Name	Hardware Name	
	+	-
c6	COLUMN 6	COLUMN 22
c7	COLUMN 7	COLUMN 23
c8	COLUMN 8	COLUMN 24
c9	COLUMN 9	COLUMN 25
c10	COLUMN 10	COLUMN 26
c11	COLUMN 11	COLUMN 27
c12	COLUMN 12	COLUMN 28
c13	COLUMN 13	COLUMN 29
c14	COLUMN 14	COLUMN 30
c15	COLUMN 15	COLUMN 31



## 4. Install the Terminal Block

To connect the TB-2631 terminal block to the PXI-2530 front panel, complete the following steps (the PXI-2530 should already be installed in a PXI chassis):

1. Plug the TB-2631 on to the front connector of the PXI-2530.
2. Tighten the top and bottom chassis screws on the back of the terminal block rear panel to hold it securely in place.

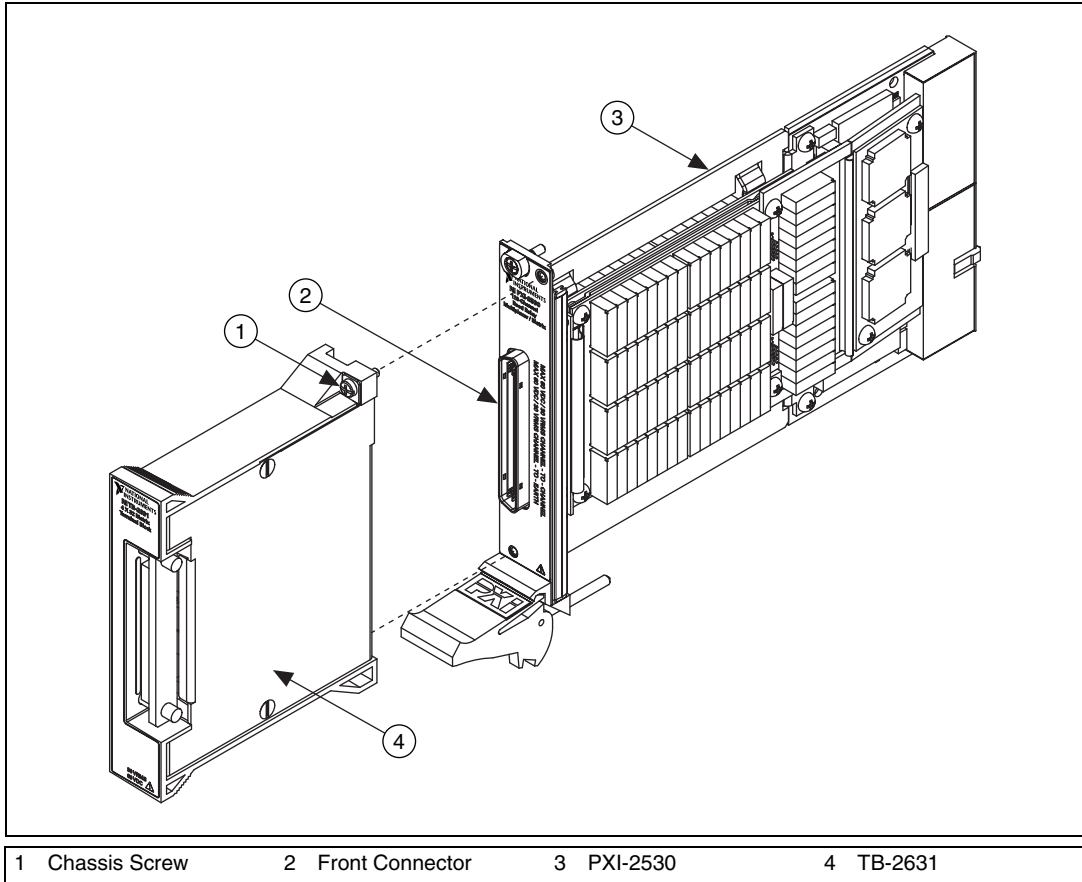

**Figure 3.** Installing the TB-2631 Terminal Block

# Compliance and Certifications

---

## Safety

This product is designed to meet the requirements of the following standards of safety for electrical equipment for measurement, control, and laboratory use:

- IEC 61010-1, EN 61010-1
- UL 3111-1, UL 61010B-1
- CAN/CSA C22.2 No. 1010.1



**Note** For UL and other safety certifications, refer to the product label, or visit [ni.com/certification](http://ni.com/certification), search by model number or product line, and click the appropriate link in the Certification column.

## Electromagnetic Compatibility

Emissions .....	EN 55011 Class A at 10 m FCC Part 15A above 1 GHz
Immunity .....	EN 61326:1997 + A2:2001, Table 1
EMC/EMI.....	CE, C-Tick, and FCC Part 15 (Class A) Compliant



**Note** For EMC compliance, you *must* operate this device with shielded cabling.

## CE Compliance

This product meets the essential requirements of applicable European Directives, as amended for CE marking, as follows:

Low-Voltage Directive (safety) .....	73/23/EEC
Electromagnetic Compatibility Directive (EMC) .....	89/336/EEC



**Note** Refer to the Declaration of Conformity (DoC) for this product for any additional regulatory compliance information. To obtain the DoC for this product, visit [ni.com/certification](http://ni.com/certification), search by model number or product line, and click the appropriate link in the Certification column.

National Instruments, NI, ni.com, and LabVIEW are trademarks of National Instruments Corporation. Refer to the *Terms of Use* section on [ni.com/legal](http://ni.com/legal) for more information about National Instruments trademarks. Other product and company names mentioned herein are trademarks or trade names of their respective companies. For patents covering National Instruments products, refer to the appropriate location: **Help»Patents** in your software, the `patents.txt` file on your CD, or [ni.com/patents](http://ni.com/patents).