

COMPREHENSIVE SERVICES

We offer competitive repair and calibration services, as well as easily accessible documentation and free downloadable resources.

SELL YOUR SURPLUS

We buy new, used, decommissioned, and surplus parts from every NI series. We work out the best solution to suit your individual needs.

 Sell For Cash  Get Credit  Receive a Trade-In Deal

OBSOLETE NI HARDWARE IN STOCK & READY TO SHIP

We stock **New**, **New Surplus**, **Refurbished**, and **Reconditioned** NI Hardware.



Bridging the gap between the manufacturer and your legacy test system.

 1-800-915-6216

 www.apexwaves.com

 sales@apexwaves.com

All trademarks, brands, and brand names are the property of their respective owners.

Request a Quote

 **CLICK HERE**

NI-9215

GETTING STARTED GUIDE

NI 9215

± 10 V, 100 kS/s/ch, 16-Bit, Simultaneous Input,
4-Channel C Series Voltage Input Module

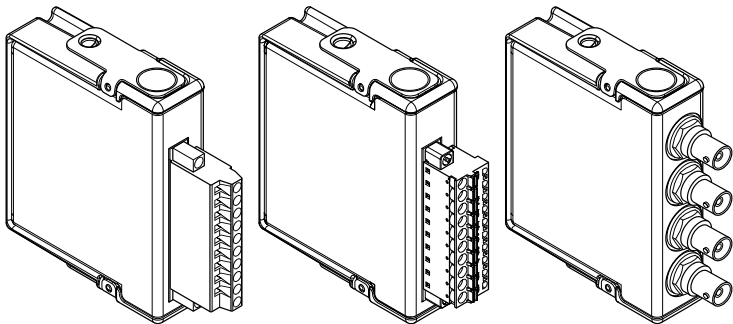

This document explains how to connect to the NI 9215. In this document, the NI 9215 with screw terminal, NI 9215 with spring terminal, and NI 9215 with BNC are referred to inclusively as the NI 9215.



Note Before you begin, complete the software and hardware installation procedures in your chassis documentation.



Note The guidelines in this document are specific to the NI 9215. The other components in the system might not meet the same safety ratings. Refer to the documentation for each component in the system to determine the safety and EMC ratings for the entire system.

Safety Guidelines

Operate the NI 9215 only as described in this document.



Caution Do not operate the NI 9215 in a manner not specified in this document. Product misuse can result in a hazard. You can compromise the safety protection built into the product if the product is damaged in any

way. If the product is damaged, return it to NI for repair.

NI 9215 with Screw Terminal and NI 9215 with Spring Terminal Safety Voltages

Connect only voltages that are within the following limits.

Channel-to-COM	± 30 V maximum
Isolation	
Channel-to-channel	None
Channel-to-earth ground	
Continuous	250 Vrms, Measurement Category II
Withstand	2,300 Vrms, verified by a 5 s dielectric withstand test

Measurement Category II is for measurements performed on circuits directly connected to the electrical distribution system. This category refers to local-level electrical distribution, such as that provided by a standard wall outlet, for example, 115 V for U.S. or 230 V for Europe.



Caution Do not connect the NI 9215 to signals or use for measurements within Measurement Categories III or IV.

NI 9215 with BNC Safety Voltages

Connect only voltages that are within the following limits.

AI+-to-AI- ± 30 V maximum

Isolation

Channel-to-channel None

Channel-to-earth ground

Continuous 60 VDC,
Measurement Category I

Withstand 1,500 Vrms, verified by a 5 s
dielectric withstand test

Measurement Category I is for measurements performed on circuits not directly connected to the electrical distribution system referred to as *MAINS* voltage. MAINS is a hazardous live electrical supply system that powers equipment. This category is for measurements of voltages from specially protected secondary circuits. Such voltage measurements include signal levels, special

equipment, limited-energy parts of equipment, circuits powered by regulated low-voltage sources, and electronics.



Note Measurement Categories CAT I and CAT O are equivalent. These test and measurement circuits are not intended for direct connection to the MAINS building installations of Measurement Categories CAT II, CAT III, or CAT IV.



Caution Do not connect the NI 9215 to signals or use for measurements within Measurement Categories II, III, or IV.

Safety Guidelines for Hazardous Voltages

You can connect hazardous voltages only to the NI 9215 with screw terminal and the NI 9215 with spring terminal. Do not connect hazardous voltages to the NI 9215 with BNC.

If hazardous voltages are connected to the device, take the following precautions. A hazardous voltage is a voltage greater than $42.4 V_{pk}$ voltage or 60 V DC to earth ground.



Caution Ensure that hazardous voltage wiring is performed only by qualified personnel adhering to local electrical standards.



Caution Do not mix hazardous voltage circuits and human-accessible circuits on the same module.



Caution Ensure that devices and circuits connected to the module are properly insulated from human contact.



Caution When module terminals are hazardous voltage LIVE ($>42.4 V_{pk}/60 V DC$), you must ensure that devices and circuits connected to the module are properly insulated from human contact. You must use the NI 9927 connector backshell kit with the NI 9215 with screw terminal and the NI 9981 connector backshell kit with the NI 9215 with spring terminal to ensure that the terminals are not accessible.

Safety Guidelines for Hazardous Locations

The NI 9215 is suitable for use in Class I, Division 2, Groups A, B, C, D, T4 hazardous locations; Class I, Zone 2, AEx nA IIC T4 and Ex nA IIC T4 hazardous locations; and nonhazardous locations only. Follow these guidelines if you are installing the NI 9215 in a potentially explosive environment. Not following these guidelines may result in serious injury or death.



Caution Do not disconnect I/O-side wires or connectors unless power has been switched off or the area is known to be nonhazardous.



Caution Do not remove modules unless power has been switched off or the area is known to be nonhazardous.



Caution Substitution of components may impair suitability for Class I, Division 2.



Caution For Division 2 and Zone 2 applications, install the system in an enclosure rated to at least IP54 as defined by IEC/EN 60079-15.



Caution For Division 2 and Zone 2 applications, connected signals must be within the following limits.

Capacitance

0.2 μ F maximum

Special Conditions for Hazardous Locations Use in Europe and Internationally

The NI 9215 has been evaluated as Ex nA IIC T4 Gc equipment under DEMKO 03 ATEX 0324020X and is IECEx UL 14.0089X certified. Each NI 9215 is marked  II 3G and is suitable for use

in Zone 2 hazardous locations, in ambient temperatures of $-40\text{ }^{\circ}\text{C} \leq T_a \leq 70\text{ }^{\circ}\text{C}$. If you are using the NI 9215 in Gas Group IIC hazardous locations, you must use the device in an NI chassis that has been evaluated as Ex nC IIC T4, Ex IIC T4, Ex nA IIC T4, or Ex nL IIC T4 equipment.



Caution You must make sure that transient disturbances do not exceed 140% of the rated voltage.



Caution The system shall only be used in an area of not more than Pollution Degree 2, as defined in IEC 60664-1.



Caution The system shall be mounted in an ATEX/IECEx-certified enclosure with a minimum ingress protection rating of at least IP54 as defined in IEC/EN 60079-15.



Caution The enclosure must have a door or cover accessible only by the use of a tool.

Safety Compliance and Hazardous Locations Standards

This product is designed to meet the requirements of the following electrical equipment safety standards for measurement, control, and laboratory use:

- IEC 61010-1, EN 61010-1
- UL 61010-1, CSA C22.2 No. 61010-1
- EN 60079-0, EN 60079-15
- IEC 60079-0: Ed 6, IEC 60079-15; Ed 4
- UL 60079-0; Ed 6, UL 60079-15; Ed 4
- CSA C22.2 No. 60079-0, CSA C22.2 No. 60079-15



Note For UL and other safety certifications, refer to the product label or the *Product Certifications and Declarations* section.

CE Compliance

This product meets the essential requirements of applicable European Directives, as follows:

- 2014/35/EU; Low-Voltage Directive (safety)
- 2014/30/EU; Electromagnetic Compatibility Directive (EMC)
- 2014/34/EU; Potentially Explosive Atmospheres (ATEX)

Electromagnetic Compatibility Guidelines

This product was tested and complies with the regulatory requirements and limits for electromagnetic compatibility (EMC) stated in the product specifications. These requirements and limits provide reasonable protection against harmful interference when the product is operated in the intended operational electromagnetic environment.

This product is intended for use in industrial locations. However, harmful interference may occur in some installations, when the product is connected to a peripheral device or test object, or if the product is used in residential or commercial areas. To minimize

interference with radio and television reception and prevent unacceptable performance degradation, install and use this product in strict accordance with the instructions in the product documentation.

Furthermore, any changes or modifications to the product not expressly approved by National Instruments could void your authority to operate it under your local regulatory rules.



Caution To ensure the specified EMC performance, operate this product only with shielded cables and accessories.



Caution Electrostatic Discharge (ESD) can damage the NI 9215. To prevent damage, use industry-standard ESD prevention measures during installation, maintenance, and operation.

Special Conditions for Marine Applications

Some models are approved for marine (shipboard) applications. To verify marine approval certification for a model, visit ni.com/product-certifications, search by model number, and click the appropriate link.



Notice In order to meet the EMC requirements for marine applications, install the model in a shielded enclosure with shielded and/or filtered power and input/output ports. In addition, take precautions when designing, selecting, and installing measurement probes and cables to ensure that the desired EMC performance is attained.

Physical Characteristics

If you need to clean the module, wipe it with a dry towel.



Tip For two-dimensional drawings and three-dimensional models of the C Series module and connectors, visit ni.com/dimensions and search by module number.

Screw-terminal wiring

Gauge	0.2 mm ² to 2.5 mm ² (26 AWG to 14 AWG) copper conductor wire
Wire strip length	13 mm (0.51 in.)

Temperature rating	90 °C minimum
Torque for screw terminals	0.5 N · m to 0.6 N · m (4.4 lb · in. to 5.3 lb · in.)
Wires per screw terminal	One wire per screw terminal; two wires per screw terminal using a 2-wire ferrule
Ferrules	0.25 mm ² to 2.5 mm ² (26 AWG to 14 AWG)
Spring-terminal wiring	
Gauge	0.2 mm ² to 2.5 mm ² (26 AWG to 14 AWG) copper conductor wire
Wire strip length	10 mm (0.39 in.)
Temperature rating	90 °C minimum
Wires per spring terminal	One wire per spring terminal; two wires per spring terminal using a 2-wire ferrule
Ferrules	0.25 mm ² to 2.5 mm ² (26 AWG to 14 AWG)

Connector securement

Securement type	Screw flanges provided
Torque for screw flanges	0.2 N · m (1.80 lb · in.)

Weight

NI 9215 with screw terminal	150 g (5.3 oz)
NI 9215 with spring terminal	138 g (4.9 oz)
NI 9215 with BNC	173 g (6.1 oz)

Preparing the Environment

Ensure that the environment in which you are using the NI 9215 meets the following specifications.

Operating temperature (IEC 60068-2-1, IEC 60068-2-2)	-40 °C to 70 °C
---	-----------------

Operating humidity (IEC 60068-2-78)	10% RH to 90% RH, noncondensing
--	------------------------------------

Pollution Degree	2
------------------	---

Maximum altitude	2,000 m
------------------	---------

Indoor use only.



Note Refer to the device datasheet on ni.com/manuals for complete specifications.

NI 9215 Pinout

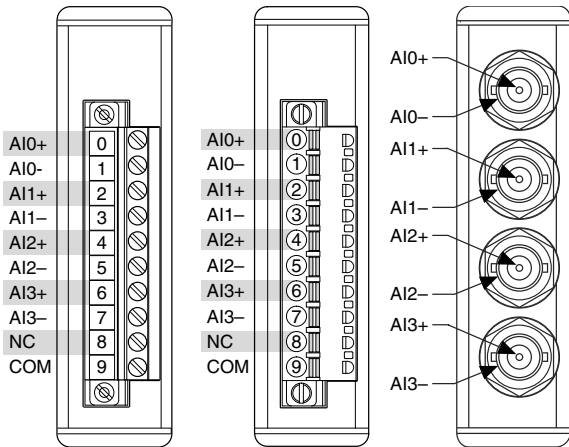
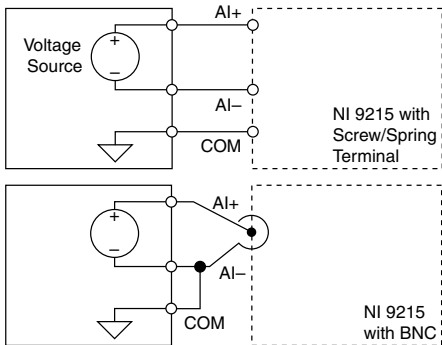

Table 1. Signal Descriptions

Signal	Description
AI+	Positive analog input signal connection
AI-	Negative analog input signal connection
COM	Common reference connection to isolated ground
NC	No connection

Grounded Differential Connections



Floating Differential Connections

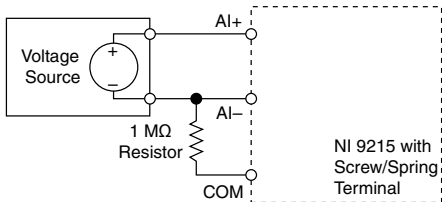

- Connect the negative lead to COM through a 1 M Ω resistor to keep the signal source within the common-mode voltage range.
- The NI 9215 with screw terminal and the NI 9215 with spring terminal does not read data accurately if the signal source is outside of the common-mode voltage range.

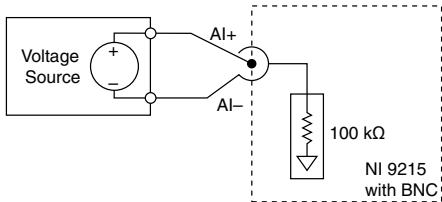

The NI 9215 with BNC has internal circuitry that maintains the common mode voltage range.

Single-Ended Connections

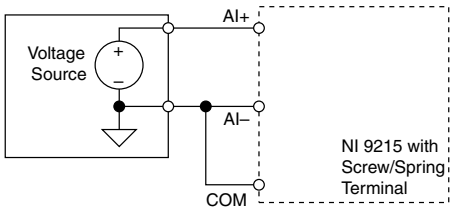

Connect the ground signal to COM to keep the signal source within the common-mode voltage range.

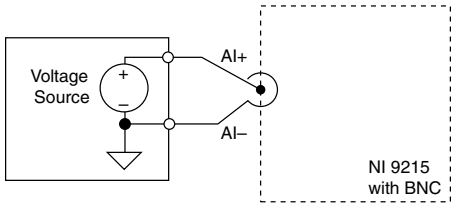

The NI 9215 with BNC has internal circuitry that maintains the common mode voltage range.

Connection Guidelines

- Make sure that devices you connect to the NI 9215 are compatible with the module specifications.
- You must use 2-wire ferrules to create a secure connection when connecting more than one wire to a single terminal on the NI 9215 with screw terminal or NI 9215 with spring terminal.

High-Vibration Application Connections

If your application is subject to high vibration, NI recommends that you follow these guidelines to protect connections to the NI 9215 with screw terminal or the NI 9215 with spring terminal:

- Use ferrules to terminate wires to the detachable connector.
- Use the NI 9927 backshell kit with the NI 9215 with screw terminal or the NI 9981 backshell kit with the NI 9215 with spring terminal.

Overvoltage Protection

The NI 9215 provides overvoltage protection for each channel.



Note Refer to the device datasheet on ni.com/manuals for more information about overvoltage protection.

Where to Go Next

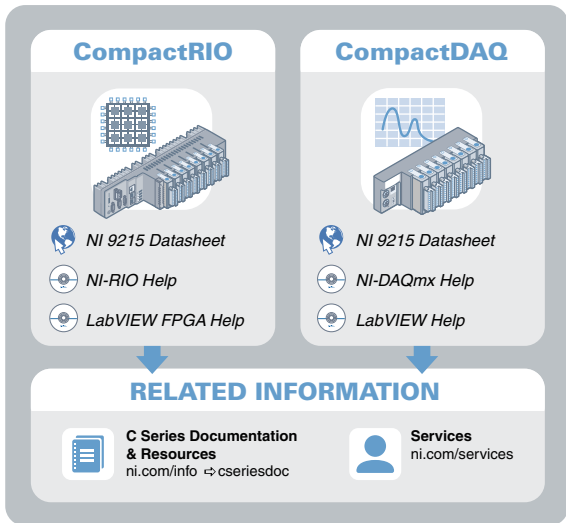

Located at ni.com/manuals



Installs with the software

Product Certifications and Declarations

Refer to the product Declaration of Conformity (DoC) for additional regulatory compliance information. To obtain product certifications and the DoC for NI products, visit ni.com/product-certifications, search by model number, and click the appropriate link.

Worldwide Support and Services

The NI website is your complete resource for technical support. At ni.com/support, you have access to everything from troubleshooting and application development self-help resources to email and phone assistance from NI Application Engineers.

Visit ni.com/services for information about the services NI offers.

Visit ni.com/register to register your NI product. Product registration facilitates technical support and ensures that you receive important information updates from NI.

NI corporate headquarters is located at 11500 North Mopac Expressway, Austin, Texas, 78759-3504. NI

also has offices located around the world. For support in the United States, create your service request at ni.com/support or dial 1 866 ASK MYNI (275 6964). For support outside the United States, visit the *Worldwide Offices* section of ni.com/niglobal to access the branch office websites, which provide up-to-date contact information.

Information is subject to change without notice. Refer to the *NI Trademarks and Logo Guidelines* at ni.com/trademarks for information on NI trademarks. Other product and company names mentioned herein are trademarks or trade names of their respective companies. For patents covering NI products/technology, refer to the appropriate location: **Help»Patents** in your software, the `patents.txt` file on your media, or the *National Instruments Patent Notice* at ni.com/patents. You can find information about end-user license agreements (EULAs) and third-party legal notices in the readme file for your NI product. Refer to the *Export Compliance Information* at ni.com/legal/export-compliance for the NI global trade compliance policy and how to obtain relevant HTS codes, ECCNs, and other import/export data. NI MAKES NO EXPRESS OR IMPLIED WARRANTIES AS TO THE ACCURACY OF THE INFORMATION CONTAINED HEREIN AND SHALL NOT BE LIABLE FOR ANY ERRORS. U.S. Government Customers: The data contained in this manual was developed at private expense and is subject to the applicable limited rights and restricted data rights as set forth in FAR 52.227-14, DFAR 252.227-7014, and DFAR 252.227-7015.

© 2004—2019 National Instruments. All rights reserved.

373779H-01 June 9, 2019