

COMPREHENSIVE SERVICES

We offer competitive repair and calibration services, as well as easily accessible documentation and free downloadable resources.

SELL YOUR SURPLUS

We buy new, used, decommissioned, and surplus parts from every NI series. We work out the best solution to suit your individual needs.

 Sell For Cash  Get Credit  Receive a Trade-In Deal

OBSOLETE NI HARDWARE IN STOCK & READY TO SHIP

We stock **New**, **New Surplus**, **Refurbished**, and **Reconditioned** NI Hardware.



Bridging the gap between the manufacturer and your legacy test system.

 1-800-915-6216

 www.apexwaves.com

 sales@apexwaves.com

All trademarks, brands, and brand names are the property of their respective owners.

Request a Quote

 **CLICK HERE**

PXI-1044

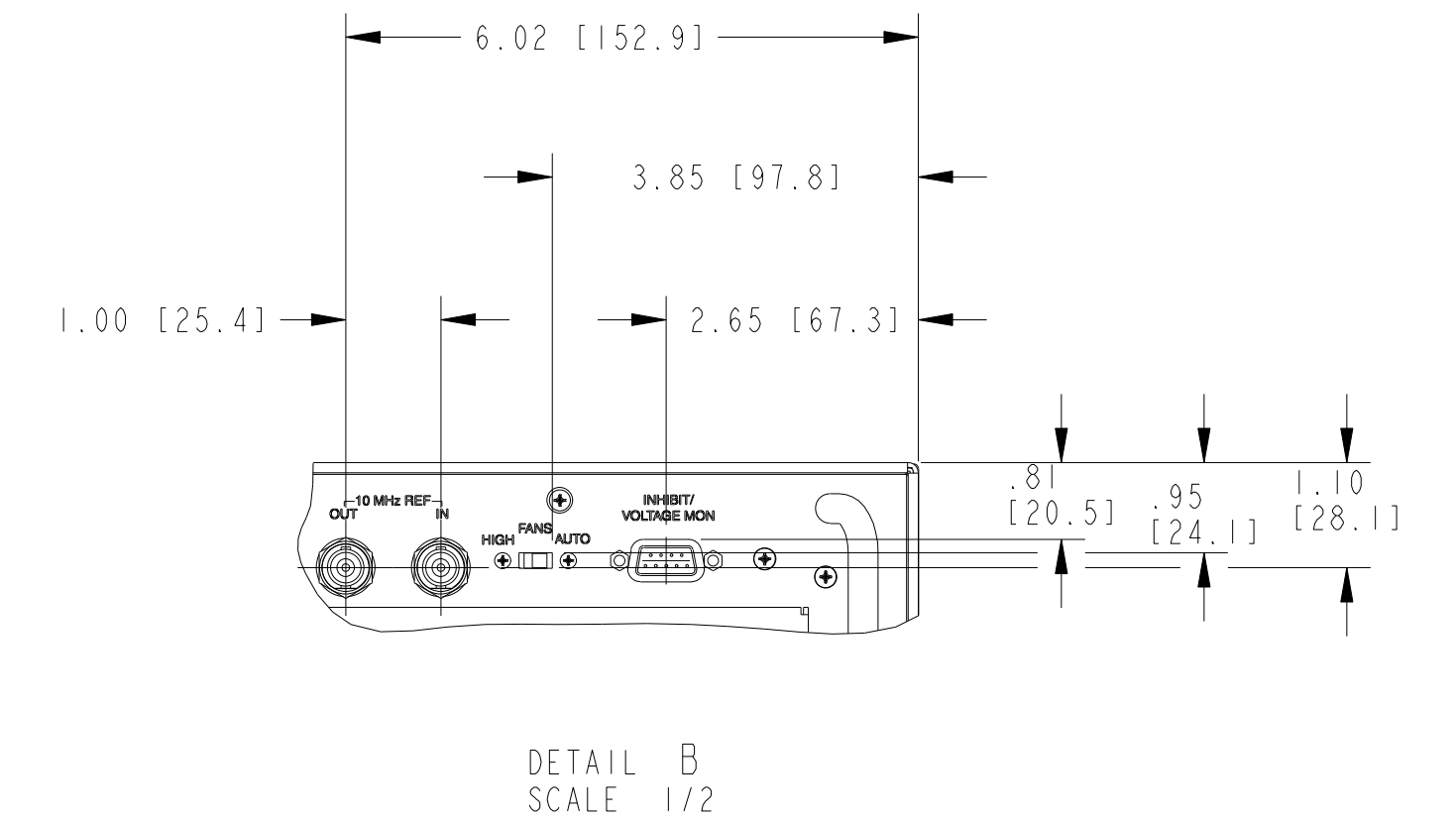
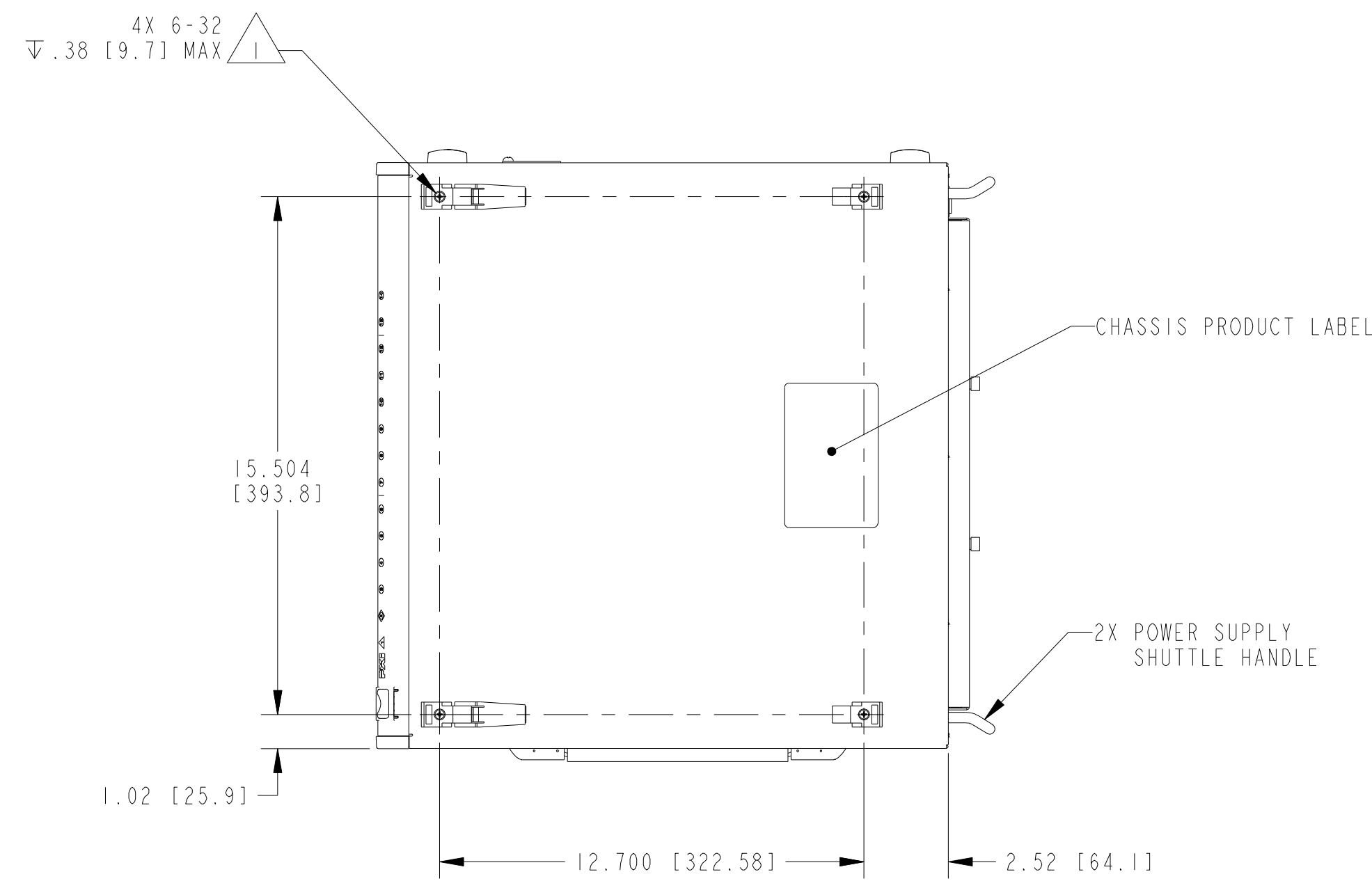
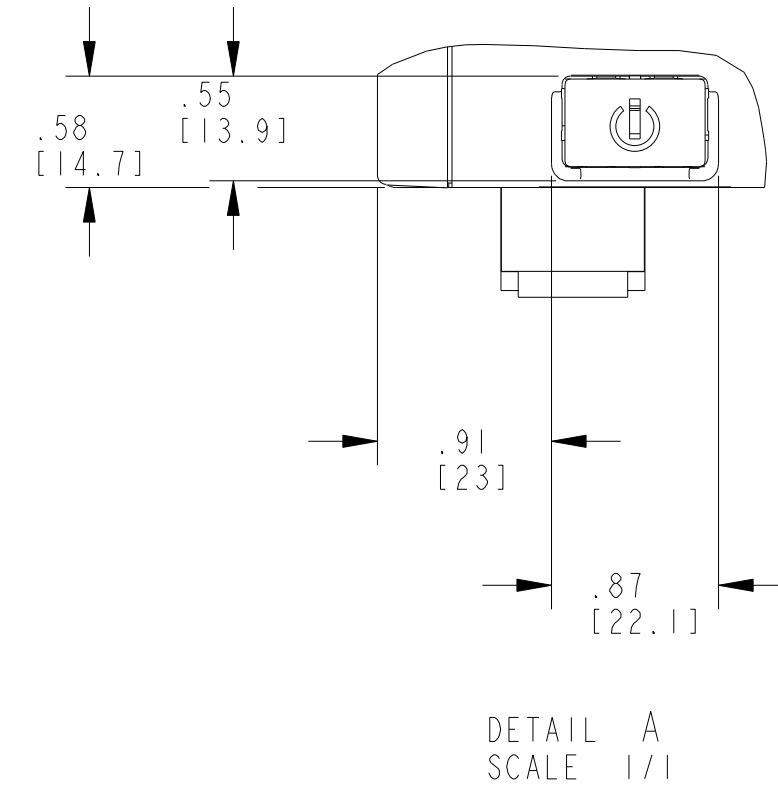
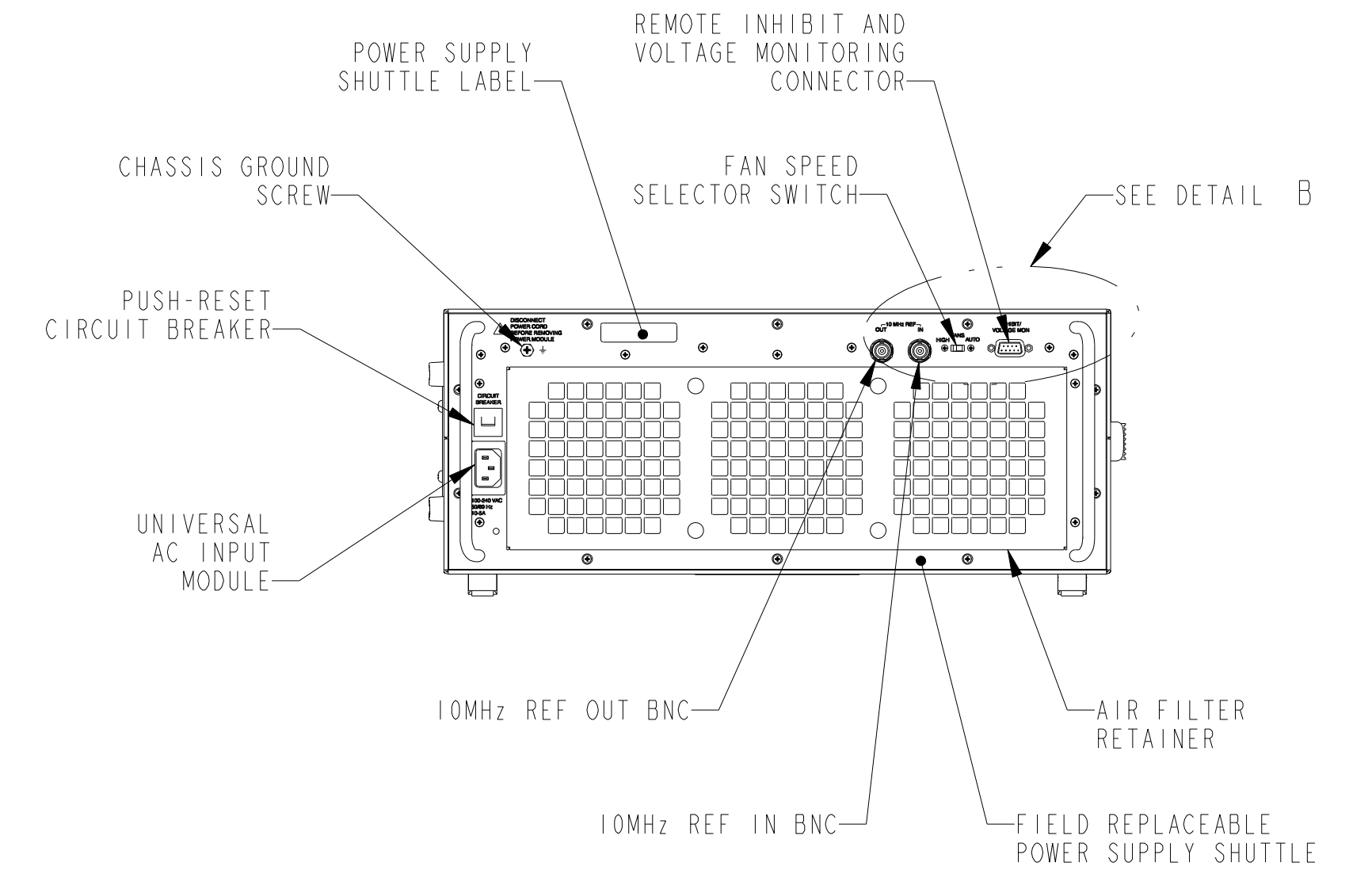
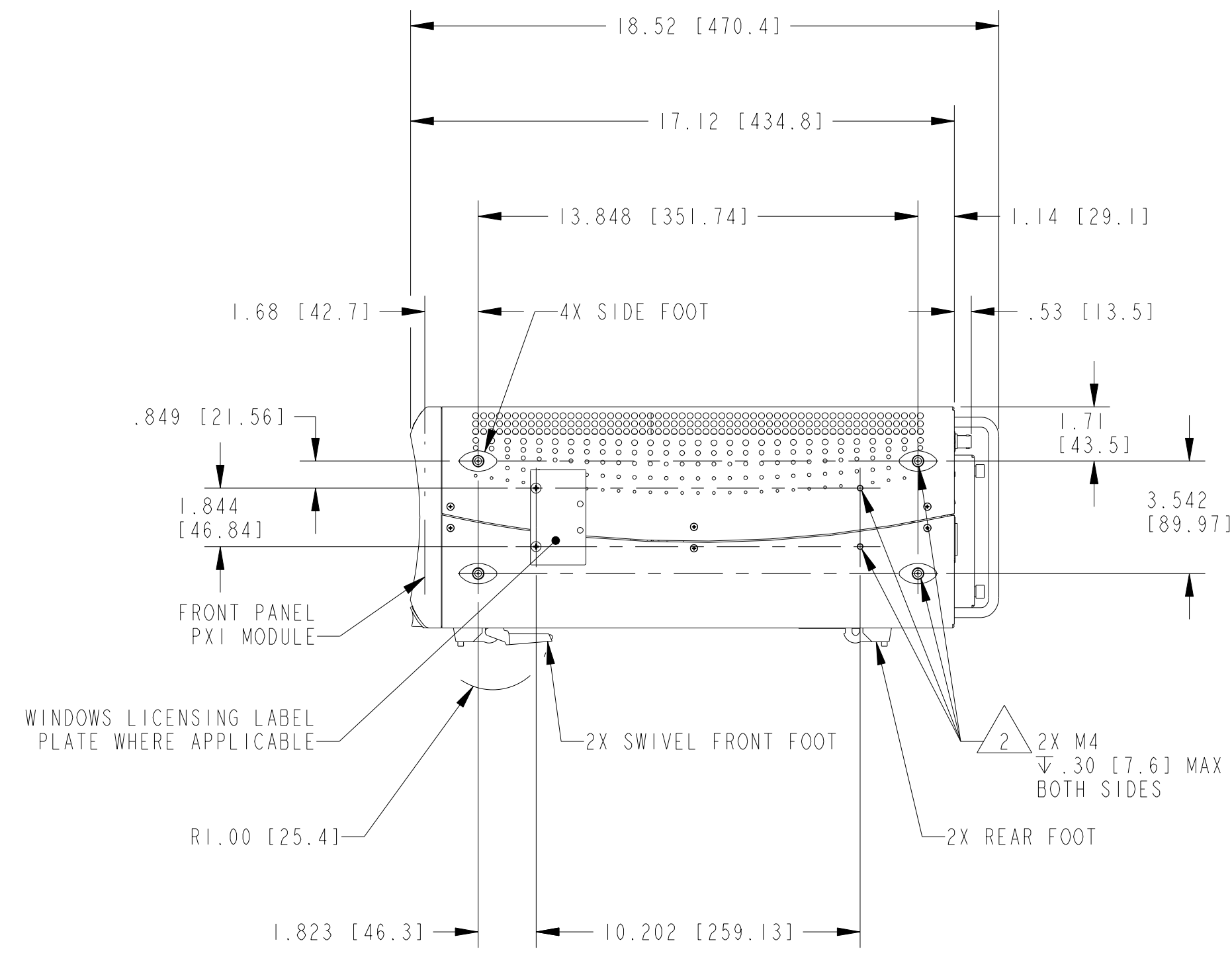
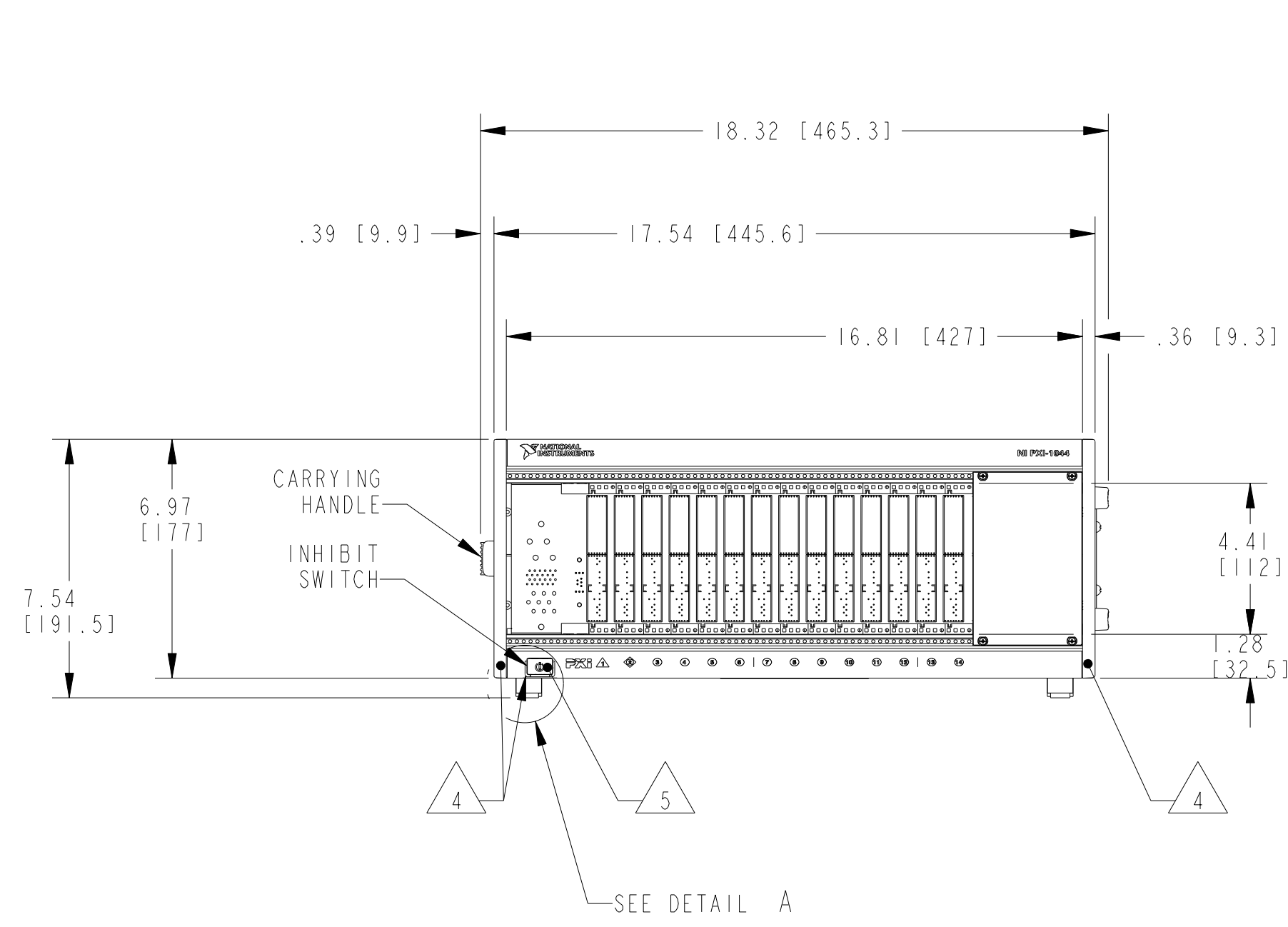

7. REFER TO PRODUCT MANUAL ON NI.COM FOR MORE DETAILS.
6. USER MUST PROVIDE MINIMUM COOLING/VENTING CLEARANCE AS SHOWN. FAILURE TO PROVIDE THIS CLEARANCE MAY RESULT IN CHASSIS OR MODULE THERMAL RELATED FAILURES.
5. WHITE PC-ABS COLOR.
4. NI COMPASS BLUE PC-ABS COLOR.
3. NI COMPASS WHITE COLOR.
2. THERE ARE FOUR HOLES ON EACH SIDE OF CHASSIS FOR OPTIONAL RACK MOUNT KIT.
1. FOUR M4 THREAD BOTTOM FEET MOUNTING HOLES MAY BE USED FOR MOUNTING CHASSIS IN CUSTOM APPLICATIONS.

NOTES: UNLESS OTHERWISE SPECIFIED.

UNLESS OTHERWISE SPECIFIED DIMENSIONS ARE IN INCHES AND [MILLIMETERS].	NATIONAL INSTRUMENTS® AUSTIN, TEXAS	
	TITLE CUSTOMER DRAWING, CHASSIS ASSEMBLY, PXI-1044	
DO NOT SCALE DRAWING THIRD ANGLE PROJECTION	SIZE CODE IDENT NO MM/DD/YYYY D 7U296 02/04/2008	
	SCALE: 1/4	SHEET 1 OF 2

COOLING AIR
 EXHAUST VENT

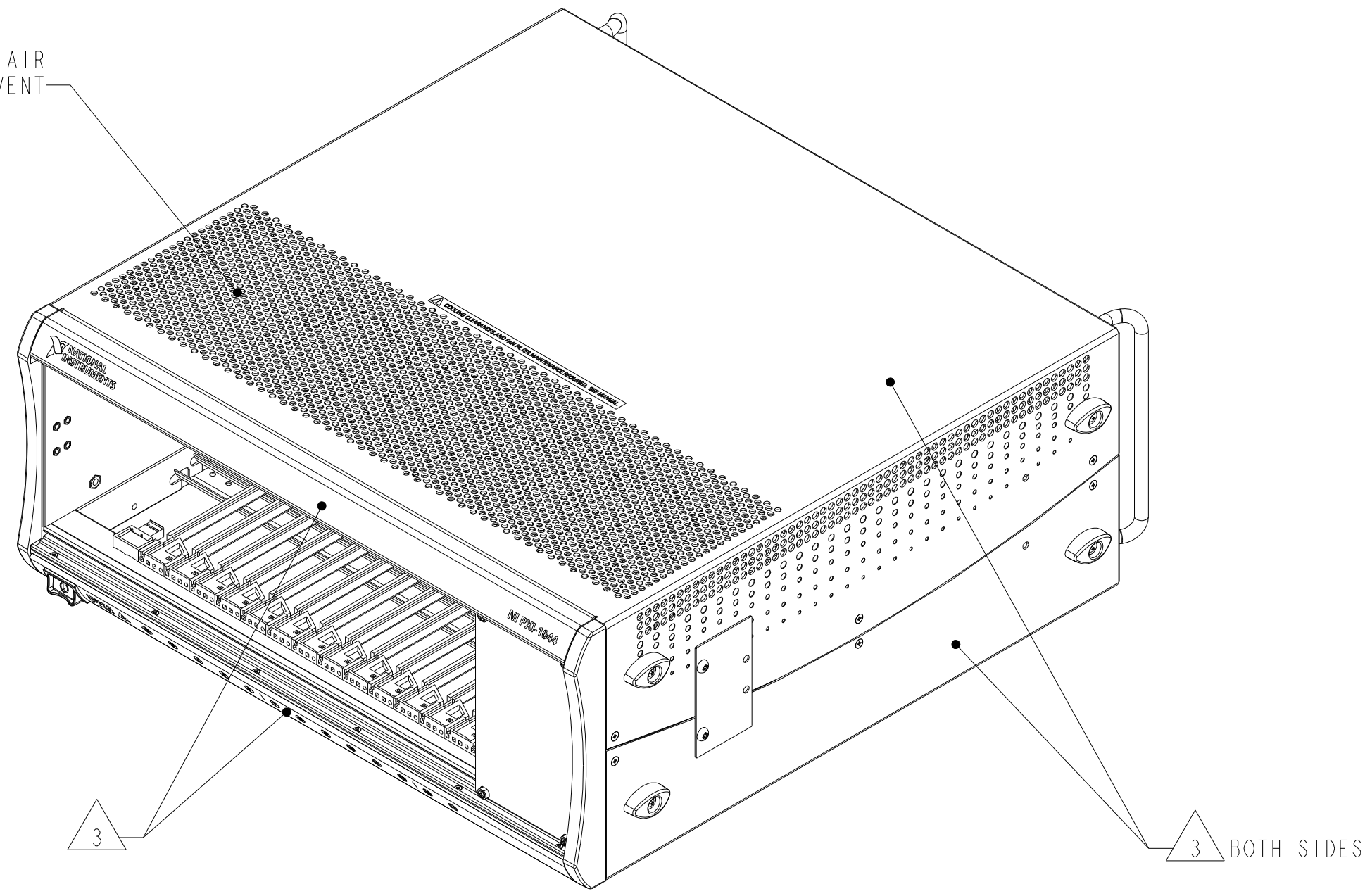

6 COOLING ENVELOPE
 ON BOTH SIDES AND TOP

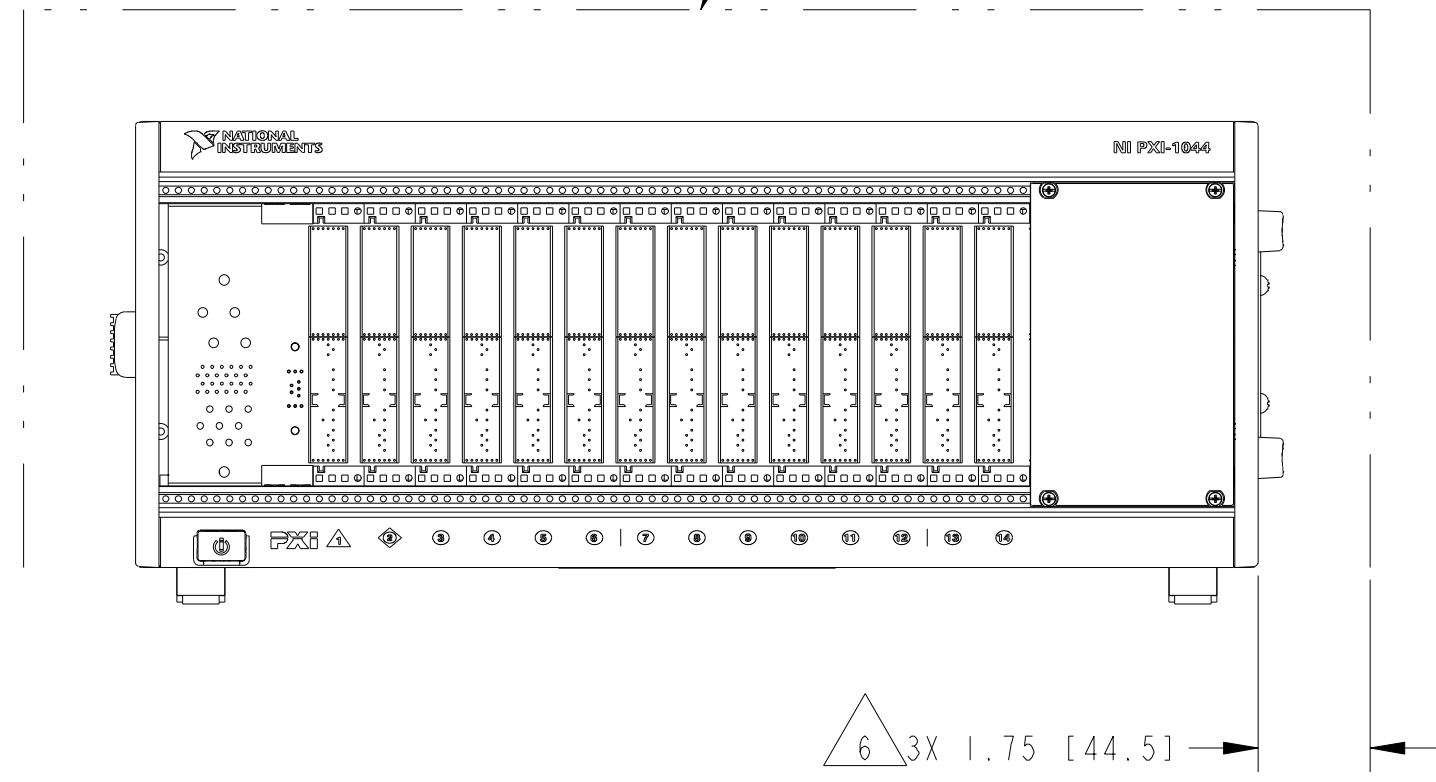

6 TOP COOLING ENVELOPE, REF

COOLING AIR INLET/EXHAUST VENT
 ON BOTH SIDES

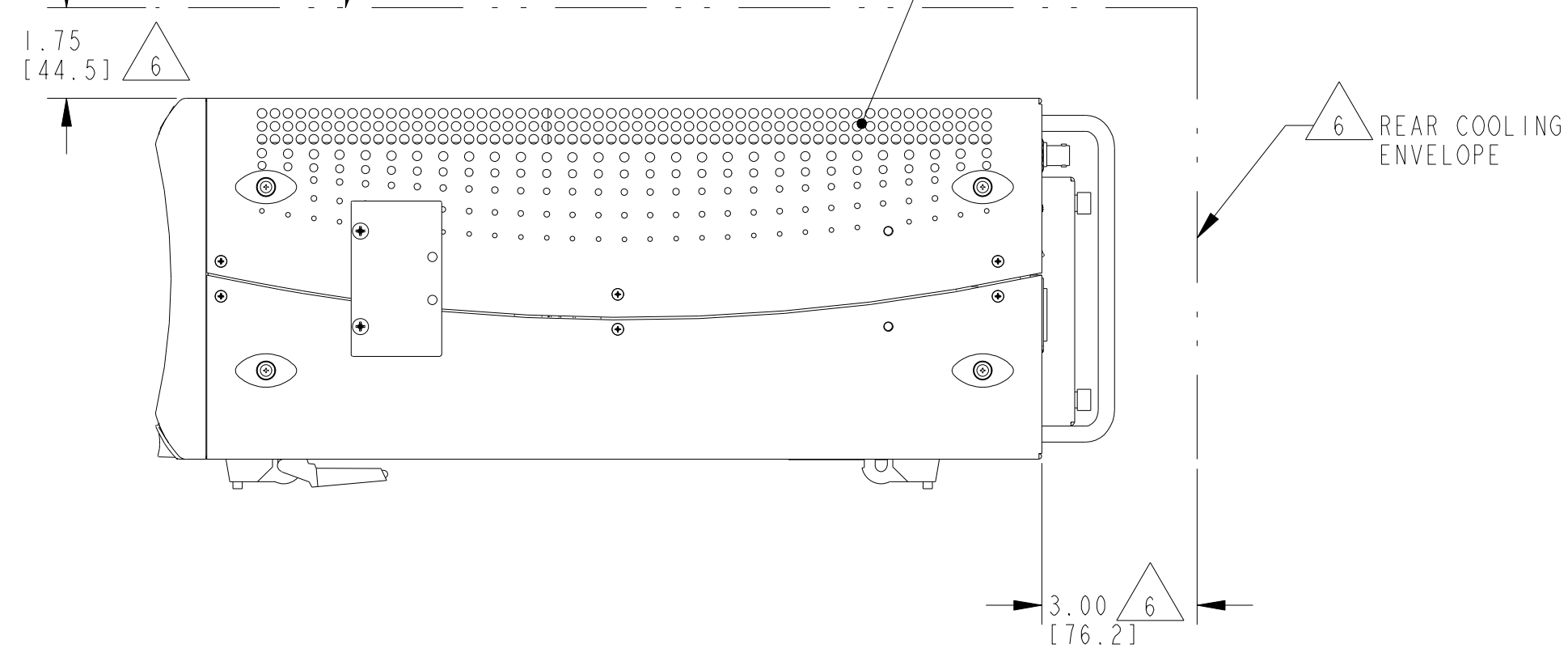

COOLING (FILTERED)
 AIR INLET VENT

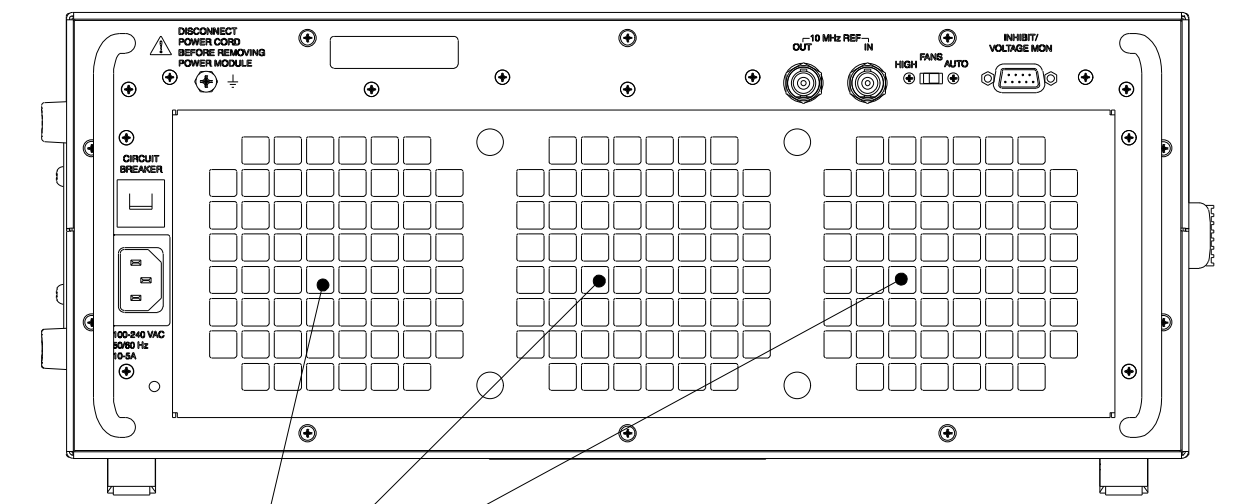

COOLING INFORMATION