

NI cRIO-9012/9014

Intelligent Real-Time Embedded Controllers for CompactRIO

Figure 1. CompactRIO cRIO-9012/9014

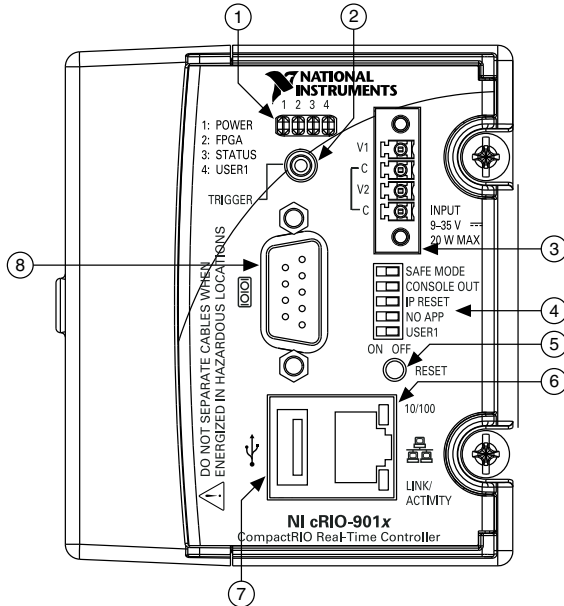

- | | |
|--------------------|------------------------|
| 1. LEDs | 5. Reset Button |
| 2. SMB Connector | 6. RJ-45 Ethernet Port |
| 3. Power Connector | 7. USB Port |
| 4. DIP Switches | 8. RS-232 Serial Port |

This document describes how to connect the cRIO-9012/9014 to a network and how to use the features of the cRIO-9012/9014. This document also contains specifications for the controllers.

Safety Guidelines for Hazardous Locations

The cRIO-9012/9014 is suitable for use in Class I, Division 2, Groups A, B, C, D, T4 hazardous locations; Class I, Zone 2, AEx nA IIC T4 and Ex nA IIC T4 hazardous locations;

and nonhazardous locations only. Follow these guidelines if you are installing the cRIO-9012/9014 in a potentially explosive environment. Not following these guidelines may result in serious injury or death.



Caution Do not disconnect the power supply wires and connectors from the controller unless power has been switched off.



Caution Do not install or remove the controller unless power has been switched off.



Caution Substitution of components may impair suitability for Class I, Division 2.



Caution For Division 2 and Zone 2 applications, install the system in an enclosure rated to at least IP54 as defined by IEC/EN 60079-15.

Special Conditions for Hazardous Locations Use in Europe and Internationally

The cRIO-9012/9014 has been evaluated as Ex nA IIC T4 Gc equipment under DEMKO Certificate No. 03 ATEX 0324020X and is IECEx UL 14.0089X certified. Each cRIO-9012/9014 is marked Ⓢ II 3G and is suitable for use in Zone 2 hazardous locations, in ambient temperatures of $-40\text{ °C} \leq T_a \leq 70\text{ °C}$. If you are using the cRIO-9012/9014 in Gas Group IIC hazardous locations, you must use the device in an NI chassis that has been evaluated as Ex nC IIC T4, Ex IIC T4, Ex nA IIC T4, or Ex nL IIC T4 equipment.



Caution You must make sure that transient disturbances do not exceed 140% of the rated voltage.



Caution The system shall only be used in an area of not more than Pollution Degree 2, as defined in IEC 60664-1.



Caution The system shall be mounted in an ATEX/IECEx-certified enclosure with a minimum ingress protection rating of at least IP54 as defined in IEC/EN 60079-15.



Caution The enclosure must have a door or cover accessible only by the use of a tool.

Electromagnetic Compatibility Guidelines

This product was tested and complies with the regulatory requirements and limits for electromagnetic compatibility (EMC) stated in the product specifications. These requirements and limits provide reasonable protection against harmful interference when the product is operated in the intended operational electromagnetic environment.

This product is intended for use in industrial locations. However, harmful interference may occur in some installations, when the product is connected to a peripheral device or test object, or if the product is used in residential or commercial areas. To minimize interference with

radio and television reception and prevent unacceptable performance degradation, install and use this product in strict accordance with the instructions in the product documentation.

Furthermore, any changes or modifications to the product not expressly approved by National Instruments could void your authority to operate it under your local regulatory rules.

Special Conditions for Marine Applications

Some products are Lloyd's Register (LR) Type Approved for marine (shipboard) applications. To verify Lloyd's Register certification for a product, visit ni.com/certification and search for the LR certificate, or look for the Lloyd's Register mark on the product.



Caution In order to meet the EMC requirements for marine applications, install the product in a shielded enclosure with shielded and/or filtered power and input/output ports. In addition, take precautions when designing, selecting, and installing measurement probes and cables to ensure that the desired EMC performance is attained.

Installing the Controller on the Chassis

The following figure shows the dimensions of the cRIO-9012/9014.

Figure 2. cRIO-9012/9014, Front and Bottom View with Dimensions

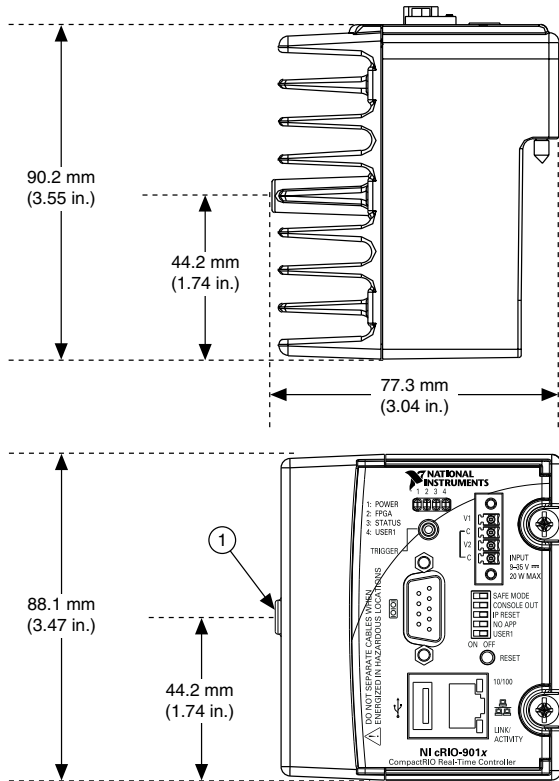

1. M4 Thread

Complete the following steps to install the controller on the chassis.

1. Make sure that no power is connected to the controller or the chassis.
2. Align the controller with the chassis as shown in the following figure.

Figure 3. Installing the cRIO-9012/9014 in the Chassis

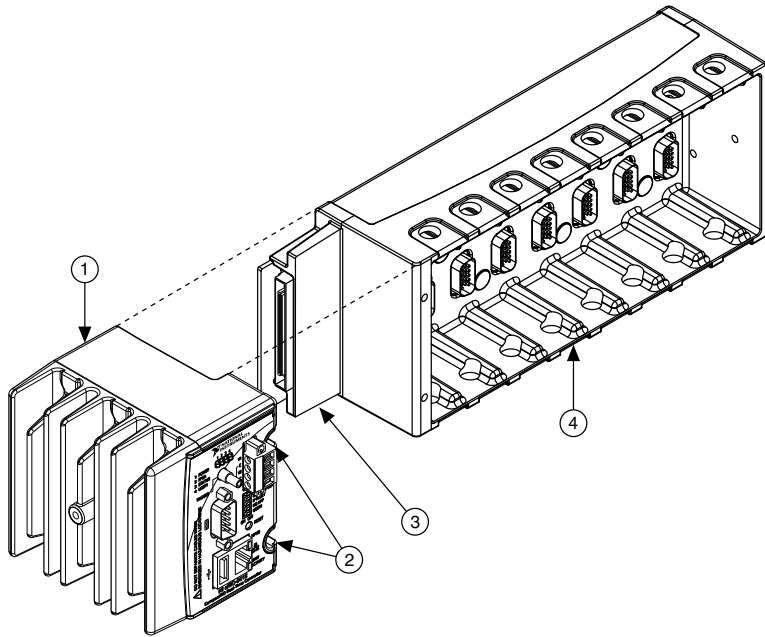

- | | |
|-------------------|------------------------------------|
| 1. Controller | 3. Controller Slot |
| 2. Captive Screws | 4. Reconfigurable Embedded Chassis |

3. Slide the controller onto the controller slot on the chassis. Press firmly to ensure the chassis connector and the controller connector are mated.
4. Using a number 2 Phillips screwdriver, tighten the two captive screws on the front of the controller to 1.3 N · m (11.5 lb · in.) of torque.

Connecting the Controller to a Network

Connect the controller to an Ethernet network using the RJ-45 Ethernet port on the controller front panel. Use a standard Category 5 (CAT-5) or better shielded, twisted-pair Ethernet cable to connect the chassis to an Ethernet hub, or use an Ethernet crossover cable to connect the chassis directly to a computer.



Caution To prevent data loss and to maintain the integrity of your Ethernet installation, do not use a cable longer than 100 m. If you are using 100 Mbps Ethernet, National Instruments recommends using a CAT-5 or better shielded twisted-pair Ethernet cable.

If you need to build your own cable, refer to the [Cabling](#) section for more information about Ethernet cable wiring connections.

The host computer communicates with the controller over a standard Ethernet connection. If the host computer is on a network, you must configure the controller on the same subnet as the

host computer. If neither the host computer nor the CompactRIO controller is connected to a network, you can connect the two directly using a crossover cable.

If you want to use the controller on a subnet other than the one the host computer is on, first connect the controller on the same subnet as the host computer. Use DHCP to assign an IP address or reassign a static IP address for the subnet where you want it to be and physically move it to the other subnet. The first time you configure the controller, you must also install software on it. Refer to the *Measurement & Automation Explorer Help* for more information about configuring the controller in Measurement & Automation Explorer (MAX). Contact your network administrator if you need assistance configuring the host computer and controller on the same subnet.

Wiring Power to the Controller



Caution You must install the controller on a CompactRIO chassis and tighten the captive screws before you apply power to the controller. Installing the controller while power is applied to it can cause damage to the chassis.

The cRIO-9012/9014 requires an external power supply that meets the specifications in the *Power Requirements* section. The cRIO-9012/9014 filters and regulates the supplied power and provides power for all of the I/O modules in the chassis. You must connect a power supply to at least one pair of V and C terminals. Optionally, you can connect a power supply to the other pair of V and C terminals. The controller draws power from the power supply with the higher voltage. The cRIO-9012/9014 has one layer of reverse-voltage protection. Complete the following steps to connect a power supply to the chassis.

1. Connect the positive lead of the power supply to the V1 or V2 terminal of the power connector shipped with the cRIO-9012/9014, and tighten the terminal screw. The following figure shows the terminal screws, which secure the wires in the screw terminals, and the connector screws, which secure the power connector on the controller.

Figure 4. Power Connector

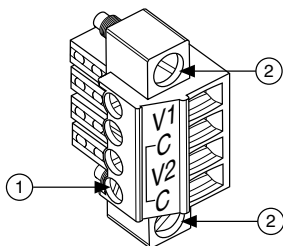

1. Terminal Screws
2. Connector Screws

2. Connect the negative lead of the power supply to one of the C terminals of the power connector and tighten the terminal screw.

- Optionally, you can connect the positive lead of another power supply to the other V terminal and the negative lead to one of the C terminals. You must install the ferrite across both pairs of wires.
- Install the power connector on the front panel of the cRIO-9012/9014 and tighten the connector screws.



Note The controller draws power from either V1 or V2 depending on which terminal has a higher voltage. It does not draw power from both terminals. The controller switches between V1 and V2 without affecting operation.



Caution The C terminals are internally connected to each other. If you use two power supplies, make sure that they share a common ground.



Caution The C terminals are internally connected to the controller chassis to prevent a faulty ground connection from causing the chassis ground to float. If you reverse the input voltage, the positive input voltage is connected directly to the chassis. The controller has built-in reversed-voltage protection, but reversed voltage can damage connected peripherals if the chassis ground is not reliably connected to earth ground.



Caution Do not tighten or loosen the terminal screws on the power connector while the power connector is plugged into the controller or while the power supply is on.

Powering On the cRIO-9012/9014

When you apply power to the cRIO-9012/9014, the controller runs a power-on self test (POST). During the POST, the Power and Status LEDs turn on. The Status LED turns off, indicating that the POST is complete.

You can configure the cRIO-9012/9014 to launch an embedded stand-alone application each time you boot the controller.

Connecting Serial Devices to the cRIO-9012/9014

The cRIO-9012/9014 has an RS-232 serial port to which you can connect devices such as displays or input devices. Use the Serial VIs to read from and write to the serial port from a LabVIEW Real-Time application. For more information about the Serial VIs, refer to the *LabVIEW Help*.

Figure 5. Controller Serial Port

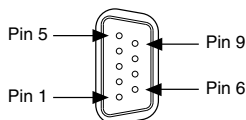

Table 1. DB-9 Pin Descriptions

Pin	Signal
1	DCD
2	RXD
3	TXD
4	DTR
5	GND
6	DSR
7	RTS
8	CTS
9	RI

Using the Internal Real-Time Clock

The system clock of the cRIO-9012/9014 is synchronized with the internal high-precision real-time clock at startup. This synchronization provides timestamp data to the controller. For information about using the internal real-time clock to correct drift of the system clock, go to ni.com/info and enter the Info Code `crioclock`. Refer to the *Specifications* section for the accuracy specifications of the real-time clock.

Using the SMB Connector for Digital I/O

You can use the SMB connector of the cRIO-9012/9014 to connect digital devices to the controller. For example, if you connect the pulse-per-second output of a GPS device to the SMB connector of the cRIO-9012/9014, you can use the GPS device to correct for drift of the system clock.

For software that supports GPS drift-correction and other digital I/O through the SMB connector, go to ni.com/info and enter the Info Code `criosmb`.

Connecting USB Mass-Storage Devices to the Controller

The cRIO-9012/9014 supports common USB mass-storage devices such as USB Flash drives and USB-to-IDE adapters formatted with FAT16 and FAT32 file systems. Storage size is limited only by the file system. The cRIO-9012/9014 does not support other types of USB devices. You can connect USB mass-storage devices to the cRIO-9012/9014 while the controller is operating. In order to avoid data loss or corruption, do not connect or disconnect

USB mass-storage devices while the controller is communicating with them. USB devices are mapped to the U: drive in LabVIEW.

Configuring DIP Switches

Figure 6. DIP Switches

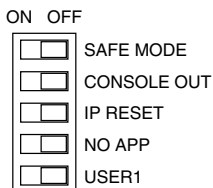

All of the DIP switches are in the OFF position when the chassis is shipped from National Instruments.

SAFE MODE Switch

The position of the SAFE MODE switch determines whether the embedded LabVIEW Real-Time engine launches at startup. If the switch is in the OFF position, the LabVIEW Real-Time engine launches. Keep this switch in the OFF position during normal operation. If the switch is in the ON position at startup, the cRIO-9012/9014 launches only the essential services required for updating its configuration and installing software. The LabVIEW Real-Time engine does not launch.

If the software on the controller is corrupted, you must put the controller into safe mode and reformat the controller drive. You can put the controller into safe mode by powering it up either with the SAFE MODE switch in the ON position or with no software installed on the drive. Refer to the *Measurement & Automation Explorer Help* for more information about installing software on a controller and reformatting the drive on the controller.

CONSOLE OUT Switch

With a serial-port terminal program, you can use the CONSOLE OUT switch to read the IP address and firmware version of the controller. Use a null-modem cable to connect the serial port on the chassis to a computer. Push the switch to the ON position. Make sure that the serial-port terminal program is configured to the following settings:

- 9,600 bits per second
- Eight data bits
- No parity
- One stop bit
- No flow control

The serial-port terminal program displays the IP address and firmware version of the controller, and alerts you when you connect an unsupported USB device to the controller. Keep this switch in the OFF position during normal operation.

IP RESET Switch

Push the IP RESET switch to the ON position and reboot the controller to reset the IP address and other TCP/IP settings of the controller to the factory defaults. Refer to the *Troubleshooting Network Communication* section for more information about resetting the IP address. You also can push this switch to the ON position to unlock a chassis that was previously locked in MAX.

NO APP Switch

Push the NO APP switch to the ON position to prevent a LabVIEW Real-Time startup application from running at startup. If you want to permanently disable a LabVIEW Real-Time application from running at startup, you must disable it in LabVIEW. To run an application at startup, push the NO APP switch to the OFF position, create an application using the LabVIEW Application Builder, and configure the application in LabVIEW to launch at startup. If you already have an application configured to launch at startup and you push the NO APP switch from ON to OFF, the startup application is automatically enabled. For more information about automatically launching VIs at startup and disabling VIs from launching at startup, refer to the *LabVIEW Help*.

USER1 Switch

You can define the USER1 switch for your application. To define the purpose of this switch in your embedded application, use the RT Read Switch VI in your LabVIEW Real-Time embedded VI. For more information about the RT Read Switch VI, refer to the *LabVIEW Help*.

Using the RESET Button

Pressing the RESET button resets the processor in the same manner as cycling power.

Understanding LED Indications

Figure 7. cRIO-9012/9014 LEDs

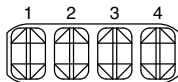

-
- | | |
|----------|-----------|
| 1. POWER | 3. STATUS |
| 2. FPGA | 4. USER1 |
-

POWER LED

The POWER LED is lit while the cRIO-9012/9014 is powered on. This LED indicates that the power supply connected to the chassis is adequate.

This LED is a bi-color LED. When the controller is powered from V1, the POWER LED is lit green. When the controller is powered from V2, the POWER LED is lit yellow.

FPGA LED

You can use the FPGA LED to help debug your application or easily retrieve application status. Use the LabVIEW FPGA Module and NI-RIO software to define the FPGA LED to meet the needs of your application. Refer to *LabVIEW Help* for information about programming this LED.

STATUS LED

The STATUS LED is off during normal operation. The cRIO-9012/9014 indicates specific error conditions by flashing the STATUS LED a certain number of times every few seconds, as shown in the following table

Number of Flashes Every Few Seconds	Indication
1	The controller is unconfigured. Use MAX to configure the controller. Refer to the <i>Measurement & Automation Explorer Help</i> for information about configuring the controller.
2	The controller has detected an error in its software. This usually occurs when an attempt to upgrade the software is interrupted. Reinstall software on the controller. Refer to the <i>Measurement & Automation Explorer Help</i> for information about installing software on the controller.
3	The controller is in safe mode because the SAFE MODE DIP switch is in the ON position or there is no software installed on the controller. Refer to the <i>Configuring DIP Switches</i> section for information about the SAFE MODE DIP switch.
4	The software has crashed twice without rebooting or cycling power between crashes. This usually occurs when the controller runs out of memory. Review your RT VI and check the memory usage. Modify the VI as necessary to solve the memory usage issue.
Continuously blinking or solid	The controller has detected an unrecoverable error. Contact NI.

USER1 LED

You can define the USER1 LED to meet the needs of your application. To define the LED, use the RT LEDs VI in LabVIEW. For more information about the RT LEDs VI, refer to the *LabVIEW Help*.

Resetting the Network Configuration of the Controller

If the controller is not able to communicate with the network, you can manually restore the unit to the factory network settings. When you reset the controller, the IP address, subnet mask, DNS address, gateway, and Time Server IP are set to 0 . 0 . 0 . 0. Resetting does not affect power-on defaults, watchdog settings, or VIs.

Complete the following steps to reset the controller.

1. Move the IP Reset DIP switch to the ON position.
2. Push the Reset button to cycle power to the controller. The Status LED flashes once, indicating that the controller IP address is unconfigured.
3. Move the IP Reset switch to the OFF position.

The network settings are restored. You can reconfigure the settings in MAX from a computer on the same subnet. Refer to the *Measurement & Automation Explorer Help* for more information about configuring the controller.



Note If the controller is restored to the factory network settings, the LabVIEW run-time engine does not load. You must reconfigure the network settings and restart the controller for the LabVIEW run-time engine to load.

cRIO-9012/9014 Specifications

The following specifications are typical for the range -40 °C to 70 °C unless otherwise noted.



Caution Do not operate the cRIO-9012/9014 in a manner not specified in this document. Product misuse can result in a hazard. You can compromise the safety protection built into the product if the product is damaged in any way. If the product is damaged, return it to NI for repair.

Network

Network interface	10Base-T and 100Base-TX Ethernet
Compatibility	IEEE 802.3
Communication rates	10 Mbps, 100 Mbps, auto-negotiated
Maximum cabling distance	100 m/segment

RS-232 Serial Port

Maximum baud rate	115,200 bps
Data bits	5, 6, 7, 8
Stop bits	1, 2

Parity	Odd, Even, Mark, Space
Flow control	RTS/CTS, XON/XOFF, DTR/DSR

SMB Connector

Output Characteristics

Logic high	3.3 V
Logic low	0 V
Driver type	CMOS
Sink/source current	±50 mA
3-state output leakage current	±5 µA

Input Characteristics

Minimum input voltage	-500 mV
Minimum low-level input voltage	990 mV
Maximum high-level input voltage	2.31 V
Maximum input voltage	5.5 V
Typical input capacitance	2.5 pF
Typical resistive strapping	1 kΩ to 3.3 V

USB Port

Maximum data rate	12 Mb/s
Maximum current	500 mA

Memory

Nonvolatile

cRIO-9012	128 MB minimum
cRIO-9014	2 GB

For information about the life span of the nonvolatile memory and about best practices for using nonvolatile memory, go to ni.com/info and enter the Info Code SSDBP.

DRAM

cRIO-9012	64 MB
cRIO-9014	128 MB

Internal Real-Time Clock

Accuracy	200 ppm; 35 ppm at 25 °C
----------	--------------------------

MTBF

The following MTBF specifications apply to the cRIO-9012/9014.

MTBF 330,481 hours at 25 °C; Bellcore Issue Level II

Power Requirements

Voltage input range

On powerup 9 V to 35 V

After powerup 6 V to 35 V



Note The cRIO-9012/9014 is guaranteed to power up when 9 V is applied to V and C. After powerup, it can operate on as little as 6 V.

Maximum power input 20 W

Maximum power consumption

Controller only 6 W

Controller supplying power to eight CompactRIO modules 20 W

Physical Characteristics

If you need to clean the module, wipe it with a dry towel.



Tip For two-dimensional drawings and three-dimensional models of the C Series module and connectors, visit ni.com/dimensions and search by module number.

Screw-terminal wiring

Gauge 0.2 mm² to 2.1 mm² (24 AWG to 14 AWG) copper conductor wire

Wire strip length 6 mm (0.24 in.) of insulation stripped from the end

Temperature rating 85 °C

Torque for screw terminals 0.20 N · m to 0.25 N · m (1.8 lb · in. to 2.2 lb · in.)

Wires per screw terminal One wire per screw terminal

Connector securement

Securement type Screw flanges provided

Torque for screw flanges 0.3 N · m to 0.4 N · m (2.7 lb · in. to 3.5 lb · in.)

Dimensions	90.2 mm × 77.3 mm × 88.1 mm (3.6 in. × 3.0 in. × 3.5 in.)
Weight	488 g (17.2 oz)

Safety Voltages

Connect only voltages that are within the following limits:

V terminal to C terminal	35 V maximum, Measurement Category I
--------------------------	--------------------------------------

Measurement Category I is for measurements performed on circuits not directly connected to the electrical distribution system referred to as *MAINS* voltage. MAINS is a hazardous live electrical supply system that powers equipment. This category is for measurements of voltages from specially protected secondary circuits. Such voltage measurements include signal levels, special equipment, limited-energy parts of equipment, circuits powered by regulated low-voltage sources, and electronics.



Note Measurement Categories CAT I and CAT O are equivalent. These test and measurement circuits are not intended for direct connection to the MAINS building installations of Measurement Categories CAT II, CAT III, or CAT IV.



Caution Do not connect the cRIO-9012/9014 to signals or use for measurements within Measurement Categories II, III, or IV.

Hazardous Locations

U.S. (UL)	Class I, Division 2, Groups A, B, C, D, T4; Class I, Zone 2, AEx nA IIC T4
Canada (C-UL)	Class I, Division 2, Groups A, B, C, D, T4; Class I, Zone 2, Ex nA IIC T4
Europe (ATEX) and International (IECEx)	Ex nA IIC T4 Gc

Safety and Hazardous Locations Standards

This product is designed to meet the requirements of the following electrical equipment safety standards for measurement, control, and laboratory use:

- IEC 61010-1, EN 61010-1
- UL 61010-1, CSA 61010-1
- EN 60079-0:2012, EN 60079-15:2010
- IEC 60079-0: Ed 6, IEC 60079-15; Ed 4
- UL 60079-0; Ed 5, UL 60079-15; Ed 3
- CSA 60079-0:2011, CSA 60079-15:2012



Note For UL and other safety certifications, refer to the product label or the [Online Product Certification](#) section.

Electromagnetic Compatibility

This product meets the requirements of the following EMC standards for sensitive electrical equipment for measurement, control, and laboratory use:

- EN 61326 (IEC 61326): Class A emissions; Industrial immunity
- EN 55011 Emissions; Group 1, Class A
- CE, C-Tick, ICES, and FCC Part 15 Emissions; Class A



Note For EMC compliance, operate this device with double-shielded cables.

CE Compliance

This product meets the essential requirements of applicable European Directives, as follows:

- 2014/35/EU; Low-Voltage Directive (safety)
- 2014/30/EU; Electromagnetic Compatibility Directive (EMC)
- 94/9/EC; Potentially Explosive Atmospheres (ATEX)

Online Product Certification

Refer to the product Declaration of Conformity (DoC) for additional regulatory compliance information. To obtain product certifications and the DoC for this product, visit ni.com/certification, search by model number or product line, and click the appropriate link in the Certification column.

Shock and Vibration

To meet these specifications, you must panel mount the system.

Operating vibration

Random (IEC 60068-2-64)	5 g _{rms} , 10 Hz to 500 Hz
Sinusoidal (IEC 60068-2-6)	5 g, 10 Hz to 500 Hz
Operating shock (IEC 60068-2-27)	30 g, 11 ms half sine; 50 g, 3 ms half sine; 18 shocks at 6 orientations

Environmental

Refer to the manual for the chassis you are using for more information about meeting these specifications.

Operating temperature (IEC 60068-2-1, IEC 60068-2-2)	-40 °C to 70 °C
---	-----------------

Storage temperature (IEC 60068-2-1, IEC 60068-2-2)	-40 °C to 85 °C
---	-----------------

Ingress protection	IP40
Operating humidity (IEC 60068-2-78)	10% RH to 90% RH, noncondensing
Storage humidity (IEC 60068-2-78)	5% RH to 95% RH, noncondensing
Pollution Degree	2
Maximum altitude	5,000 m

Indoor use only.

Environmental Management

NI is committed to designing and manufacturing products in an environmentally responsible manner. NI recognizes that eliminating certain hazardous substances from our products is beneficial to the environment and to NI customers.

For additional environmental information, refer to the *Minimize Our Environmental Impact* web page at ni.com/environment. This page contains the environmental regulations and directives with which NI complies, as well as other environmental information not included in this document.

Waste Electrical and Electronic Equipment (WEEE)



EU Customers At the end of the product life cycle, all NI products must be disposed of according to local laws and regulations. For more information about how to recycle NI products in your region, visit ni.com/environment/weee.

电子信息产品污染控制管理办法（中国 RoHS）



中国客户 National Instruments 符合中国电子信息产品中限制使用某些有害物质指令 (RoHS)。关于 National Instruments 中国 RoHS 合规性信息, 请登录 ni.com/environment/rohs_china。(For information about China RoHS compliance, go to ni.com/environment/rohs_china.)

Cabling

The following table shows the standard Ethernet cable wiring connections for both normal and crossover cables.

Table 2. Ethernet Cable Wiring Connections

Pin	Connector 1	Connector 2 (Normal)	Connector 2 (Crossover)
1	white/orange	white/orange	white/green
2	orange	orange	green
3	white/green	white/green	white/orange
4	blue	blue	blue

Table 2. Ethernet Cable Wiring Connections (Continued)

Pin	Connector 1	Connector 2 (Normal)	Connector 2 (Crossover)
5	white/blue	white/blue	white/blue
6	green	green	orange
7	white/brown	white/brown	white/brown
8	brown	brown	brown

Figure 8. Ethernet Connector Pinout

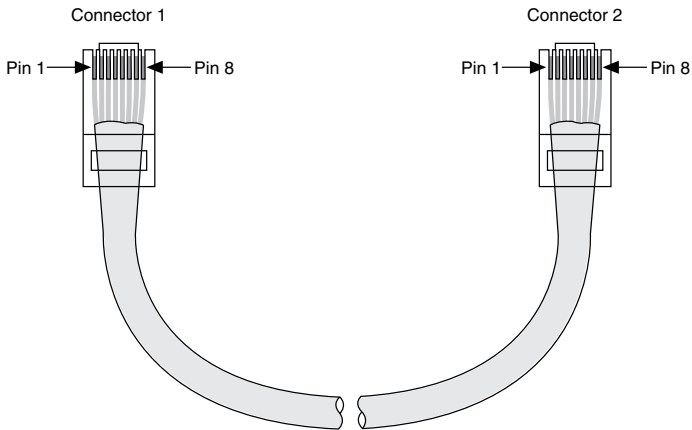

Worldwide Support and Services

The NI website is your complete resource for technical support. At ni.com/support, you have access to everything from troubleshooting and application development self-help resources to email and phone assistance from NI Application Engineers.

Visit ni.com/services for NI Factory Installation Services, repairs, extended warranty, and other services.

Visit ni.com/register to register your NI product. Product registration facilitates technical support and ensures that you receive important information updates from NI.

A Declaration of Conformity (DoC) is our claim of compliance with the Council of the European Communities using the manufacturer's declaration of conformity. This system affords the user protection for electromagnetic compatibility (EMC) and product safety. You can obtain the DoC for your product by visiting ni.com/certification. If your product supports calibration, you can obtain the calibration certificate for your product at ni.com/calibration.

NI corporate headquarters is located at 11500 North Mopac Expressway, Austin, Texas, 78759-3504. NI also has offices located around the world. For telephone support in the United States, create your service request at ni.com/support or dial 1 866 ASK MYNI (275 6964). For telephone support outside the United States, visit the *Worldwide Offices* section of ni.com/niglobal to access the branch office websites, which provide up-to-date contact information, support phone numbers, email addresses, and current events.

Refer to the *NI Trademarks and Logo Guidelines* at ni.com/trademarks for information on NI trademarks. Other product and company names mentioned herein are trademarks or trade names of their respective companies. For patents covering NI products/technology, refer to the appropriate location: **Help»Patents** in your software, the `patents.txt` file on your media, or the *National Instruments Patent Notice* at ni.com/patents. You can find information about end-user license agreements (EULAs) and third-party legal notices in the readme file for your NI product. Refer to the *Export Compliance Information* at ni.com/legal/export-compliance for the NI global trade compliance policy and how to obtain relevant HTS codes, ECCNs, and other import/export data. NI MAKES NO EXPRESS OR IMPLIED WARRANTIES AS TO THE ACCURACY OF THE INFORMATION CONTAINED HEREIN AND SHALL NOT BE LIABLE FOR ANY ERRORS. U.S. Government Customers: The data contained in this manual was developed at private expense and is subject to the applicable limited rights and restricted data rights as set forth in FAR 52.227-14, DFAR 252.227-7014, and DFAR 252.227-7015.

© 2006—2016 National Instruments. All rights reserved.

374126G-01 Mar16