

## COMPREHENSIVE SERVICES

We offer competitive repair and calibration services, as well as easily accessible documentation and free downloadable resources.

## SELL YOUR SURPLUS

We buy new, used, decommissioned, and surplus parts from every NI series. We work out the best solution to suit your individual needs.

 Sell For Cash    Get Credit    Receive a Trade-In Deal

## OBSOLETE NI HARDWARE IN STOCK & READY TO SHIP

We stock **New**, **New Surplus**, **Refurbished**, and **Reconditioned** NI Hardware.



*Bridging the gap between the manufacturer and your legacy test system.*

 1-800-915-6216

 [www.apexwaves.com](http://www.apexwaves.com)

 [sales@apexwaves.com](mailto:sales@apexwaves.com)

*All trademarks, brands, and brand names are the property of their respective owners.*

**Request a Quote**

 **CLICK HERE**

**PXI-1033**

# PXI

## NI PXI-1033 User Manual

## **Worldwide Technical Support and Product Information**

[ni.com](http://ni.com)

## **Worldwide Offices**

Visit [ni.com/niglobal](http://ni.com/niglobal) to access the branch office Web sites, which provide up-to-date contact information, support phone numbers, email addresses, and current events.

## **National Instruments Corporate Headquarters**

11500 North Mopac Expressway Austin, Texas 78759-3504 USA Tel: 512 683 0100

For further support information, refer to the *Technical Support and Professional Services* appendix. To comment on National Instruments documentation, refer to the National Instruments Web site at [ni.com/info](http://ni.com/info) and enter the Info Code feedback.

# Important Information

---

## Warranty

The PXI-1033 is warranted against defects in materials and workmanship for a period of one year from the date of shipment, as evidenced by receipts or other documentation. National Instruments will, at its option, repair or replace equipment that proves to be defective during the warranty period. This warranty includes parts and labor.

The media on which you receive National Instruments software are warranted not to fail to execute programming instructions, due to defects in materials and workmanship, for a period of 90 days from date of shipment, as evidenced by receipts or other documentation. National Instruments will, at its option, repair or replace software media that do not execute programming instructions if National Instruments receives notice of such defects during the warranty period. National Instruments does not warrant that the operation of the software shall be uninterrupted or error free.

A Return Material Authorization (RMA) number must be obtained from the factory and clearly marked on the outside of the package before any equipment will be accepted for warranty work. National Instruments will pay the shipping costs of returning to the owner parts which are covered by warranty.

National Instruments believes that the information in this document is accurate. The document has been carefully reviewed for technical accuracy. In the event that technical or typographical errors exist, National Instruments reserves the right to make changes to subsequent editions of this document without prior notice to holders of this edition. The reader should consult National Instruments if errors are suspected. In no event shall National Instruments be liable for any damages arising out of or related to this document or the information contained in it.

EXCEPT AS SPECIFIED HEREIN, NATIONAL INSTRUMENTS MAKES NO WARRANTIES, EXPRESS OR IMPLIED, AND SPECIFICALLY DISCLAIMS ANY WARRANTY OF MERCHANTABILITY OR FITNESS FOR A PARTICULAR PURPOSE. CUSTOMER'S RIGHT TO RECOVER DAMAGES CAUSED BY FAULT OR NEGLIGENCE ON THE PART OF NATIONAL INSTRUMENTS SHALL BE LIMITED TO THE AMOUNT THEREFORE PAID BY THE CUSTOMER. NATIONAL INSTRUMENTS WILL NOT BE LIABLE FOR DAMAGES RESULTING FROM LOSS OF DATA, PROFITS, USE OF PRODUCTS, OR INCIDENTAL OR CONSEQUENTIAL DAMAGES, EVEN IF ADVISED OF THE POSSIBILITY THEREOF. This limitation of the liability of National Instruments will apply regardless of the form of action, whether in contract or tort, including negligence. Any action against National Instruments must be brought within one year after the cause of action accrues. National Instruments shall not be liable for any delay in performance due to causes beyond its reasonable control. The warranty provided herein does not cover damages, defects, malfunctions, or service failures caused by owner's failure to follow the National Instruments installation, operation, or maintenance instructions; owner's modification of the product; owner's abuse, misuse, or negligent acts; and power failure or surges, fire, flood, accident, actions of third parties, or other events outside reasonable control.

## Copyright

Under the copyright laws, this publication may not be reproduced or transmitted in any form, electronic or mechanical, including photocopying, recording, storing in an information retrieval system, or translating, in whole or in part, without the prior written consent of National Instruments Corporation.

National Instruments respects the intellectual property of others, and we ask our users to do the same. NI software is protected by copyright and other intellectual property laws. Where NI software may be used to reproduce software or other materials belonging to others, you may use NI software only to reproduce materials that you may reproduce in accordance with the terms of any applicable license or other legal restriction.

## End-User License Agreements and Third-Party Legal Notices

You can find end-user license agreements (EULAs) and third-party legal notices in the following locations:

- Notices are located in the <National Instruments>\\_Legal Information and <National Instruments> directories.
- EULAs are located in the <National Instruments>\Shared\MDF\Legal\license directory.
- Review <National Instruments>\\_Legal Information.txt for more information on including legal information in installers built with NI products.

## Trademarks

LabVIEW, National Instruments, NI, ni.com, the National Instruments corporate logo, and the Eagle logo are trademarks of National Instruments Corporation. Refer to the *Trademark Information* at [ni.com/trademarks](http://ni.com/trademarks) for other National Instruments trademarks. Other product and company names mentioned herein are trademarks or trade names of their respective companies.

Members of the National Instruments Alliance Partner Program are business entities independent from National Instruments and have no agency, partnership, or joint-venture relationship with National Instruments.

## Patents

For patents covering National Instruments products/technology, refer to the appropriate location: **Help»Patents** in your software, the `patents.txt` file on your media, or the *National Instruments Patent Notice* at [ni.com/patents](http://ni.com/patents).

## Export Compliance Information

Refer to the *Export Compliance Information* at [ni.com/legal/export-compliance](http://ni.com/legal/export-compliance) for the National Instruments global trade compliance policy and how to obtain relevant HTS codes, ECCNs, and other import/export data.

## WARNING REGARDING USE OF NATIONAL INSTRUMENTS PRODUCTS

(1) NATIONAL INSTRUMENTS PRODUCTS ARE NOT DESIGNED WITH COMPONENTS AND TESTING FOR A LEVEL OF RELIABILITY SUITABLE FOR USE IN OR IN CONNECTION WITH SURGICAL IMPLANTS OR AS CRITICAL COMPONENTS IN ANY LIFE SUPPORT SYSTEMS WHOSE FAILURE TO PERFORM CAN REASONABLY BE EXPECTED TO CAUSE SIGNIFICANT INJURY TO A HUMAN.

(2) IN ANY APPLICATION, INCLUDING THE ABOVE, RELIABILITY OF OPERATION OF THE SOFTWARE PRODUCTS CAN BE IMPAIRED BY ADVERSE FACTORS, INCLUDING BUT NOT LIMITED TO FLUCTUATIONS IN ELECTRICAL POWER SUPPLY, COMPUTER HARDWARE MALFUNCTIONS, COMPUTER OPERATING SYSTEM SOFTWARE FITNESS, FITNESS OF COMPILERS AND DEVELOPMENT SOFTWARE USED TO DEVELOP AN APPLICATION, INSTALLATION ERRORS, SOFTWARE AND HARDWARE COMPATIBILITY PROBLEMS, MALFUNCTIONS OR FAILURES OF ELECTRONIC MONITORING OR CONTROL DEVICES, TRANSIENT FAILURES OF ELECTRONIC SYSTEMS (HARDWARE AND/OR SOFTWARE), UNANTICIPATED USES OR MISUSES, OR ERRORS ON THE PART OF THE USER OR APPLICATIONS DESIGNER (ADVERSE FACTORS SUCH AS THESE ARE HEREAFTER COLLECTIVELY TERMED "SYSTEM FAILURES"). ANY APPLICATION WHERE A SYSTEM FAILURE WOULD CREATE A RISK OF HARM TO PROPERTY OR PERSONS (INCLUDING THE RISK OF BODILY INJURY AND DEATH) SHOULD NOT BE RELIANT SOLELY UPON ONE FORM OF ELECTRONIC SYSTEM DUE TO THE RISK OF SYSTEM FAILURE. TO AVOID DAMAGE, INJURY, OR DEATH,

THE USER OR APPLICATION DESIGNER MUST TAKE REASONABLY PRUDENT STEPS TO PROTECT AGAINST SYSTEM FAILURES, INCLUDING BUT NOT LIMITED TO BACK-UP OR SHUT DOWN MECHANISMS. BECAUSE EACH END-USER SYSTEM IS CUSTOMIZED AND DIFFERS FROM NATIONAL INSTRUMENTS' TESTING PLATFORMS AND BECAUSE A USER OR APPLICATION DESIGNER MAY USE NATIONAL INSTRUMENTS PRODUCTS IN COMBINATION WITH OTHER PRODUCTS IN A MANNER NOT EVALUATED OR CONTEMPLATED BY NATIONAL INSTRUMENTS, THE USER OR APPLICATION DESIGNER IS ULTIMATELY RESPONSIBLE FOR VERIFYING AND VALIDATING THE SUITABILITY OF NATIONAL INSTRUMENTS PRODUCTS WHENEVER NATIONAL INSTRUMENTS PRODUCTS ARE INCORPORATED IN A SYSTEM OR APPLICATION, INCLUDING, WITHOUT LIMITATION, THE APPROPRIATE DESIGN, PROCESS AND SAFETY LEVEL OF SUCH SYSTEM OR APPLICATION.

# Compliance

---

## Electromagnetic Compatibility Information

This hardware has been tested and found to comply with the applicable regulatory requirements and limits for electromagnetic compatibility (EMC) as indicated in the hardware's Declaration of Conformity (DoC)<sup>1</sup>. These requirements and limits are designed to provide reasonable protection against harmful interference when the hardware is operated in the intended electromagnetic environment. In special cases, for example when either highly sensitive or noisy hardware is being used in close proximity, additional mitigation measures may have to be employed to minimize the potential for electromagnetic interference.

While this hardware is compliant with the applicable regulatory EMC requirements, there is no guarantee that interference will not occur in a particular installation. To minimize the potential for the hardware to cause interference to radio and television reception or to experience unacceptable performance degradation, install and use this hardware in strict accordance with the instructions in the hardware documentation and the DoC<sup>1</sup>.

If this hardware does cause interference with licensed radio communications services or other nearby electronics, which can be determined by turning the hardware off and on, you are encouraged to try to correct the interference by one or more of the following measures:

- Reorient the antenna of the receiver (the device suffering interference).
- Relocate the transmitter (the device generating interference) with respect to the receiver.
- Plug the transmitter into a different outlet so that the transmitter and the receiver are on different branch circuits.

Some hardware may require the use of a metal, shielded enclosure (windowless version) to meet the EMC requirements for special EMC environments such as, for marine use or in heavy industrial areas. Refer to the hardware's user documentation and the DoC<sup>1</sup> for product installation requirements.

When the hardware is connected to a test object or to test leads, the system may become more sensitive to disturbances or may cause interference in the local electromagnetic environment.

Operation of this hardware in a residential area is likely to cause harmful interference. Users are required to correct the interference at their own expense or cease operation of the hardware.

Changes or modifications not expressly approved by National Instruments could void the user's right to operate the hardware under the local regulatory rules.



Caution To ensure the specified EMC performance, operate this product only with shielded cables and accessories.

---

<sup>1</sup> The Declaration of Conformity (DoC) contains important EMC compliance information and instructions for the user or installer. To obtain the DoC for this product, visit [ni.com/certification](http://ni.com/certification), search by model number or product line, and click the appropriate link in the Certification column.

# Contents

---

## About This Manual

Conventions .....	viii
Related Documentation.....	ix

## Chapter 1 Getting Started

Unpacking .....	1-1
What You Need to Get Started .....	1-1
Key Features .....	1-2
Chassis Description.....	1-3
Optional Equipment .....	1-5
EMC Filler Panels .....	1-5
Rack Mount Kit .....	1-5
Handle/Feet Kit .....	1-5
NI PXI-1033 Backplane Overview .....	1-6
Interoperability with CompactPCI .....	1-6
MXI Interface .....	1-6
Star Trigger Slot .....	1-6
Peripheral Slots.....	1-7
Local Bus .....	1-7
Trigger Bus .....	1-8
System Reference Clock.....	1-8

## Chapter 2 Installation and Configuration

Safety Information .....	2-1
Chassis Cooling Considerations .....	2-2
Providing Adequate Clearance .....	2-2
Setting Fan Speed .....	2-3
Installing Filler Panels .....	2-3
Rack Mounting .....	2-4
Connecting Safety Ground.....	2-4
Connecting to Power Source.....	2-4
Getting Started With The System .....	2-4
Unpacking The MXI-Express Host Card.....	2-5
Hardware Installation.....	2-5
Installing an NI ExpressCard Module .....	2-5
Installing an NI PCI Express Host Card.....	2-7

Cabling .....	2-9
Powering Up the MXI-Express System .....	2-10
Powering Down the MXI-Express System .....	2-10
Checking LEDs for Status.....	2-11
Functional Overview .....	2-11
MXI-Express Cable Options .....	2-12
Installing PXI Modules.....	2-12
PXI System Configuration with MAX.....	2-13
Basic PXI System Configuration .....	2-14
Trigger Configuration in MAX.....	2-15
Using System Configuration and Initialization Files .....	2-16

## **Chapter 3**

### **Maintenance**

Service Interval.....	3-1
Preparation.....	3-1
Cleaning.....	3-1
Interior Cleaning .....	3-2
Exterior Cleaning .....	3-2
Cleaning and Replacing the Fan Filter .....	3-2

## **Appendix A**

### **Specifications**

## **Appendix B**

### **Pinouts**

## **Appendix C**

### **Technical Support and Professional Services**

## **Glossary**

## **Index**



# About This Manual

---

The *NI PXI-1033 User Manual* contains information about installing, configuring, using, and maintaining the NI PXI-1033 chassis.

## Conventions

---

The following conventions are used in this manual:

»

The » symbol leads you through nested menu items and dialog box options to a final action. The sequence **Options»Settings»General** directs you to pull down the **Options** menu, select the **Settings** item, and select **General** from the last dialog box.



This icon denotes a note, which alerts you to important information.



This icon denotes a caution, which advises you of precautions to take to avoid injury, data loss, or a system crash. When this symbol is marked on a product, refer to the *Read Me First: Safety and Electromagnetic Compatibility* document, shipped with the product, for precautions to take.

**bold**

Bold text denotes items that you must select or click in the software, such as menu items and dialog box options. Bold text also denotes parameter names.

*italic*

Italic text denotes variables, emphasis, a cross-reference, or an introduction to a key concept. Italic text also denotes text that is a placeholder for a word or value that you must supply.

monospace

Text in this font denotes text or characters that you should enter from the keyboard, sections of code, programming examples, and syntax examples. This font is also used for the proper names of disk drives, paths, directories, programs, subprograms, subroutines, device names, functions, operations, variables, filenames, and extensions.

## Related Documentation

---

The following documents contain information that you might find helpful as you read this manual:

- *CompactPCI Specification PICMG 2.0 R 3.0*
- *PXI Hardware Specification*
- *PXI Software Specification*
- IEEE 1101.1-1991, *IEEE Standard for Mechanical Core Specifications for Microcomputers Using IEC 603-2 Connectors*
- IEEE 1101.10, *IEEE Standard for Additional Mechanical Specifications for Microcomputers Using IEEE 1101.1 Equipment Practice*

---

# Getting Started

This chapter describes the key features of the NI PXI-1033 chassis, and lists the kit contents and optional equipment you can order from National Instruments.

## Unpacking

---

Carefully inspect the shipping container and the chassis for damage. Check for visible damage to the metal work. Check to make sure all handles, hardware, and switches are undamaged. Inspect the inner chassis for any possible damage, debris, or detached components. If damage appears to have been caused during shipment, file a claim with the carrier. Retain the packing material for possible inspection and/or reshipment.

## What You Need to Get Started

---

- NI PXI-1033 chassis
- Filler panels
- AC power cable—refer to Table 1-1 for AC power cables
- NI PXI-1033 User Manual*
- Read Me First: Safety and Electromagnetic Compatibility*
- Driver CD-ROM containing NI PXI chassis software
- Chassis number labels
- MXI-Express x1 cable
- MXI-Express x1 host controller card

**Table 1-1.** AC Power Cables

<b>Power Cable</b>	<b>Reference Standards</b>
Standard 120 V (USA)	NEMA 5-15
Switzerland 220 V	SEV
Australia 240 V	AS C112
Universal Euro 230 V	CEE (7), II, IV, VII IEC83
North America 240 V	NEMA 6-15
United Kingdom 230 V	BS 1363/IEC83
Japan 100 V	JIS C8303

If you are missing any of the items listed in Table 1-1, or if you have the incorrect AC power cable, contact National Instruments.

## Key Features

---

The NI PXI-1033 combines a 5-slot PXI backplane with a structural design that has been optimized for maximum usability in a wide range of applications.

The key features of the chassis include the following:

- Accepts 3U PXI and CompactPCI (PICMG 2.0 R 3.0) modules
- 5 peripheral slots in a rugged, compact chassis with universal AC input, and automatic voltage/frequency ranging
- Integrated MXI-Express controller
- On/Off (Standby) power switch on the front panel for easy access
- AUTO/HIGH temperature-controlled fan speed based on air-intake temperature to minimize audible noise
- Carrying handle for portability (Optional)
- Rack mountable

# Chassis Description

Figure 1-1 and Figure 1-2 show the key features of the NI PXI-1033 chassis front and rear panels. Figure 1-1 shows the front view of the NI PXI-1033. Figure 1-2 shows the rear view of the NI PXI-1033. Figure 1-3 shows the bottom of the chassis.

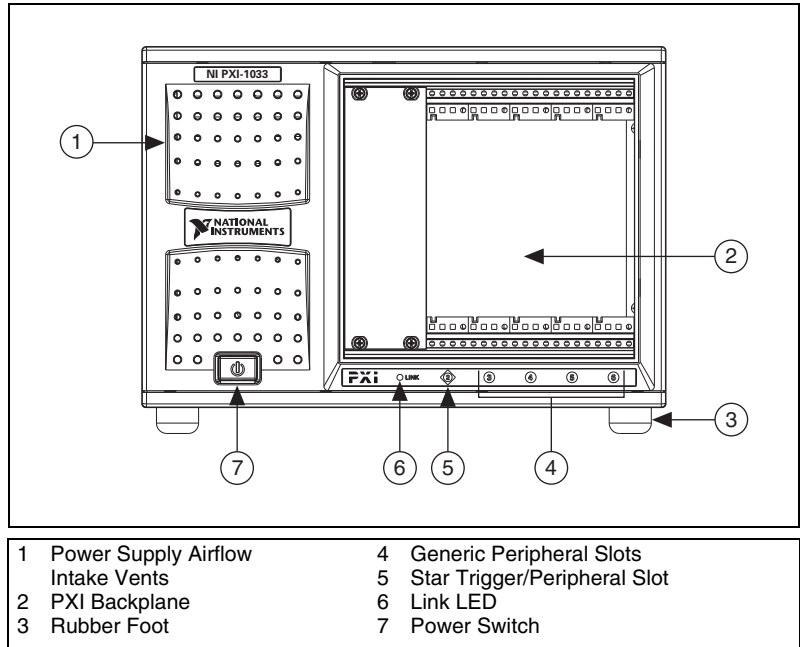

**Figure 1-1.** Front View of the NI PXI-1033 Chassis

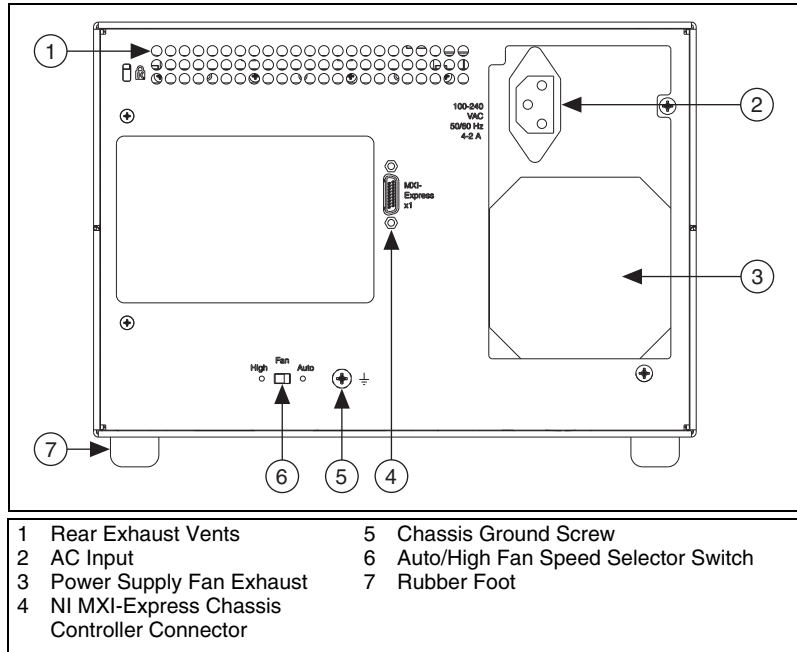

**Figure 1-2.** Rear View of the NI PXI-1033 Chassis

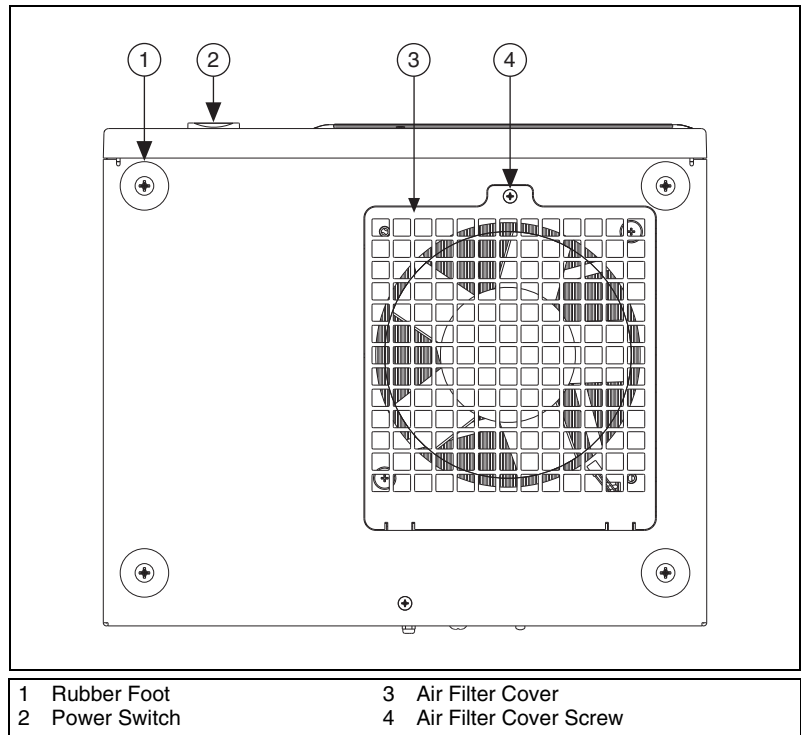

**Figure 1-3.** Bottom View of the NI PXI-1033 Chassis

## Optional Equipment

Contact National Instruments to order the following options for the NI PXI-1033 chassis.

### EMC Filler Panels

Optional EMC filler panel kits are available from National Instruments.

### Rack Mount Kit

A rack mount kit option is available for mounting the NI PXI-1033 chassis into a 19 in. instrument cabinet.

### Handle/Feet Kit

An optional side handle and rubber feet kit is available from National Instruments to provide a handle for portability.

# NI PXI-1033 Backplane Overview

---

## Interoperability with CompactPCI

The NI PXI-1033 backplane is interoperable with 5 V and universal PXI-compatible products and standard CompactPCI products. This is an important feature, because some PXI systems may require components that do not implement PXI-specific features. For example, you may want to use a standard CompactPCI network interface card in a PXI chassis.

The signals on the backplane P1 connectors meet the requirements of the CompactPCI specification for both peripheral and system modules. Refer to Appendix B, *Pinouts*, for pinout information.

The PXI-specific signals are on the backplane P2 connectors and are found only on those signal lines reserved or not used in the CompactPCI 64-bit specification. Therefore, all modules that meet the requirements of the CompactPCI 64-bit specification will function in the NI PXI-1033. Refer to Appendix B, *Pinouts*, for pinout information.



**Note** The NI PXI-1033 backplane is 32-bit PCI. 64-bit CompactPCI cards will operate in 32-bit mode in this chassis.

The chassis backplane has +5 V V(I/O). Refer to the *CompactPCI Specification PICMG 2.0 R 3.0* for details regarding V(I/O).

## MXI Interface

The NI PXI-1033 chassis has a built-in x1 MXI-Express interface that can be accessed through the MXI-Express chassis controller connector on the back of the chassis, as shown in Figure 1-2.

The MXI interface can be cabled to a remote system with a host card using a x1 MXI-Express cable to provide control of the NI PXI-1033 chassis.

## Star Trigger Slot

The star trigger (ST) slot is slot 2. This slot has dedicated equal-length trigger lines between slot 2 and peripheral slots 3 through 6 (refer to Figure 1-4). Slot 2 is intended for modules with ST functionality that can provide individual triggers to all other peripheral modules. However, if you do not require advanced trigger functionality, you can install any standard peripheral module in this slot.



The star trigger slot can also be used to provide a PXI\_CLK10 signal to the backplane. For more information regarding PXI\_CLK10, refer to the [System Reference Clock](#) section.

## Peripheral Slots

There are five peripheral slots, including the star trigger slot.

## Local Bus

The PXI backplane local bus is a daisy-chained bus that connects each peripheral slot with adjacent peripheral slots to the left and right (refer to Figure 1-4). For example, the right local bus of slot 2 connects to the left local bus of slot 3, and so on.

The left local bus signal lines on slot 2 are used for star trigger. The right local bus signal lines on slot 6 are not routed anywhere.

Each local bus is 13 lines wide and can pass analog signals up to 42 V between cards or provide a high-speed TTL side-band digital communication path that does not reduce the PXI bus bandwidth.

Initialization software uses the configuration information specific to adjacent peripheral modules to evaluate local bus compatibility.

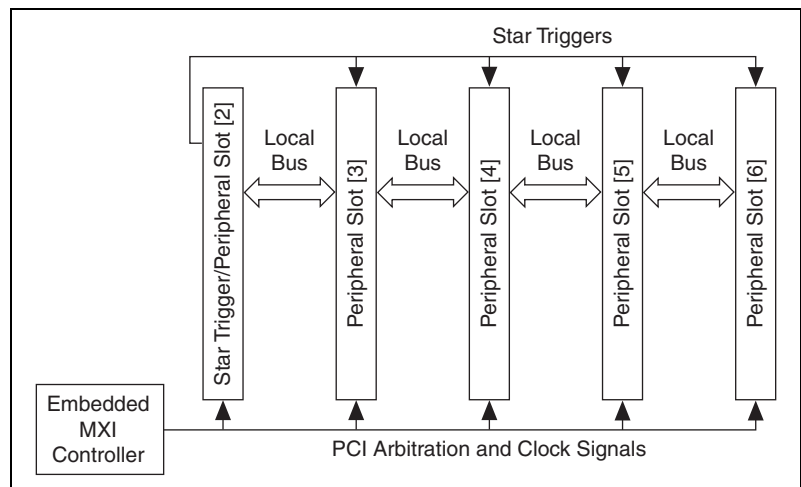

**Figure 1-4.** PXI Star Trigger and Local Bus Routing

## Trigger Bus

All slots share eight PXI trigger lines. You can use these trigger lines in a variety of ways. For example, you can use triggers to synchronize the operation of several different PXI peripheral modules. In other applications, one module located in slot 2 can control carefully timed sequences of operations performed on other modules in the system. Modules can pass triggers to one another, allowing precisely timed responses to asynchronous external events the system is monitoring or controlling.

## System Reference Clock

The NI PXI-1033 supplies the PXI 10 MHz system clock signal (PXI\_CLK10) independently to each peripheral slot. An independent buffer (having a source impedance matched to the backplane and a skew of less than 250 ps between slots) drives the clock signal to each peripheral slot. You can use this common reference clock signal to synchronize multiple modules in a measurement or control system. You can drive PXI\_CLK10 from an external source through the PXI\_CLK10\_IN pin on the P2 connector of the star trigger slot. Refer to Table B-2, [P2 \(J2\) Connector Pinout for the Star Trigger Slot](#). You must manually switch S1 on the chassis backplane to enable or disable routing an external clock to peripheral slots.

---

# Installation and Configuration

This chapter describes how to install, configure, and use the NI PXI-1033 chassis.

Before connecting the chassis to a power source, read this chapter and the *Read Me First: Safety and Electromagnetic Compatibility* document included with your chassis.

---

## Safety Information



**Caution** Before undertaking any troubleshooting, maintenance, or exploratory procedure, carefully read the following caution notices.

This equipment contains voltage hazardous to human life and safety, and is capable of inflicting personal injury.

- **Chassis Grounding**—The chassis requires a connection from the premise wire safety ground to the chassis ground. The earth safety ground must be connected during use of this equipment to minimize shock hazards. Refer to the [Connecting Safety Ground](#) section for instructions on connecting safety ground.
- **Live Circuits**—Operating personnel and service personnel *must not* remove protective covers when operating or servicing the chassis. Adjustments and service to internal components must be undertaken by qualified service technicians. During service of this product, the mains connector to the premise wiring must be disconnected. Dangerous voltages may be present under certain conditions; use extreme caution.
- **Explosive Atmosphere**—Do *not* operate the chassis in conditions where flammable gases are present. Under such conditions, this equipment is unsafe and may ignite the gases or gas fumes.

- **Part Replacement**—Only service this equipment with parts that are exact replacements, both electrically and mechanically. Contact National Instruments for replacement part information. Installation of parts with those that are not direct replacements may cause harm to personnel operating the chassis. Furthermore, damage or fire may occur if replacement parts are unsuitable.
- **Modification**—Do *not* modify any part of the chassis from its original condition. Unsuitable modifications may result in safety hazards.

## Chassis Cooling Considerations

---

The chassis is designed to operate on a bench or in an instrument rack. Determine how you want to use the chassis and follow the appropriate installation instructions.

### Providing Adequate Clearance

Apertures in the top, bottom, front, rear, and along the right side of the chassis facilitate power supply and module cooling. Air enters through filters and fan inlet in the bottom of the chassis for module cooling. It then exits through the upper sections at the right side, back, and through the top, as shown in Figure 2-1. Air cooling the power supply enters the front of the chassis, which is shown in Figure 1-1, [Front View of the NI PXI-1033 Chassis](#), then exits through the rear of the chassis, which is shown in Figure 1-2, [Rear View of the NI PXI-1033 Chassis](#). Place the chassis on a bench top or in an instrument rack so that the fans (air inlets) and the air outlet apertures along the right side, the top, and the back of the chassis have adequate ventilation. Provide at least 44.5 mm (1.75 in.) clearance above, behind, and on the sides of the unit for adequate venting. High-power applications may require additional clearance.

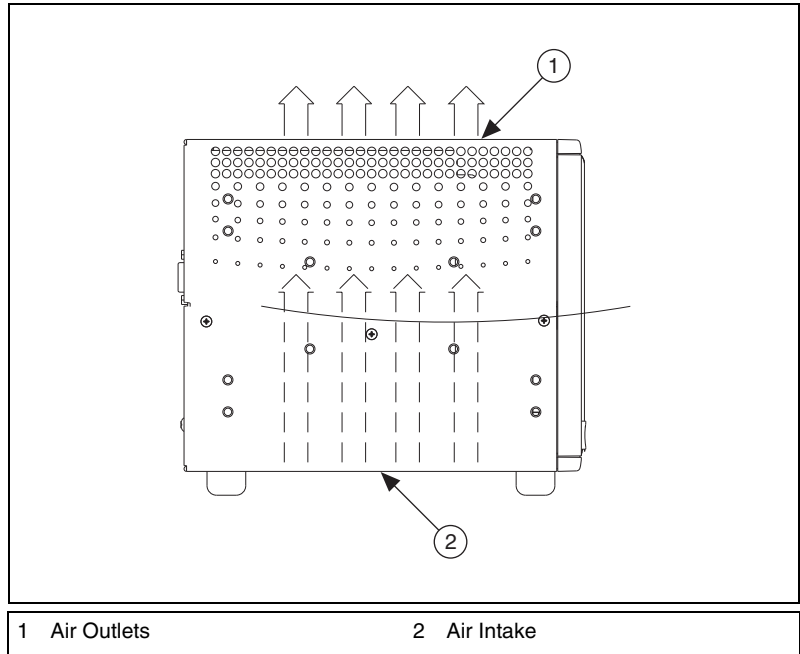

**Figure 2-1.** NI PXI-1033 Module Cooling Airflow Side View

Install the chassis so that you can easily access the bottom panel. This simplifies replacing the air filters, if necessary.

## Setting Fan Speed

The AUTO/HIGH fan-speed selector switch is on the rear panel of the NI PXI-1033. Refer to Figure 1-2, *Rear View of the NI PXI-1033 Chassis*, to locate the fan-speed selector switch. Select HIGH for maximum cooling performance (recommended) or AUTO for quieter operation. The fan speed is determined by chassis intake air temperature when set to AUTO.

## Installing Filler Panels

To improve module cooling performance, install filler panels (provided with the chassis) in unused or empty slots. Secure with the captive mounting screws provided.

## Rack Mounting

---

Rack mount applications require the optional rack mount kits available from National Instruments. Refer to Figure A-3, [NI PXI-1033 Rack Mount Kit Components](#), and the instructions supplied with the rack mount kits to install your chassis in an instrument rack.



**Note** You may want to remove the feet from the chassis when rack mounting. To do so, remove the screws holding the feet in place.

## Connecting Safety Ground

---



**Caution** The NI PXI-1033 chassis is designed with a three-position inlet that connects the cord set ground line to the chassis ground. To minimize shock hazard, make sure the electrical power outlet you use to power the chassis has an appropriate earth safety ground.

## Connecting to Power Source

---



**Cautions** Do *not* install modules prior to performing the following power-on test.

To completely remove power, you *must* disconnect the power cable.

Attach input power through the rear AC inlet using the appropriate AC power cable supplied. Refer to Figure 1-2, [Rear View of the NI PXI-1033 Chassis](#), to locate the AC inlet.

The power switch allows you to power on the chassis or place it in standby mode. Press the power switch to the On position (if not already on). Observe that all fans become operational.

## Getting Started With The System

---

To set up and use your MXI-Express cards, you need the following:

- One NI MXI-Express x1 host card (PCI Express or ExpressCard) and one NI PXI-1033
- A MXI-Express x1 cable
- A host PC with an available x1 (or wider) PCI Express slot or a laptop with an available ExpressCard slot

# Unpacking The MXI-Express Host Card

---

Your MXI-Express card is shipped in antistatic packages to prevent electrostatic damage (ESD) to the devices. ESD can damage several components on the device.



**Caution** *Never* touch the exposed pins of connectors. Doing so may damage the device.

To avoid such damage in handling the device, take the following precautions:

- Ground yourself using a grounding strap or by holding a grounded object.
- Touch the antistatic package to a metal part of the computer chassis before removing the device from the package.

Remove the device from the package and inspect the device for loose components or any sign of damage. Notify NI if the device appears damaged in any way. Do *not* install a damaged device into the computer or PXI/CompactPCI chassis.

Store the device in the antistatic envelope when not in use.

## Hardware Installation

---

The following are general instructions for installing the MXI-Express card. Consult your computer user manual or technical reference manual for specific instructions and warnings.



**Note** The software for your MXI-Express kit is included with the current NI driver CD, and is installed with the PXI platform software included as part of NI-VISA and other NI driver software products.

## Installing an NI ExpressCard Module

Because a laptop is not grounded, follow this procedure to safely connect it to your PXI system:

1. Install the NI ExpressCard module as directed in the previous section.
2. Touch the NI ExpressCard module and a metal part of the PXI chassis simultaneously.

3. Connect the cable to the NI ExpressCard module and the NI PXI-1033 chassis.
4. Plug the NI ExpressCard module into an available ExpressCard slot.

If your computer is already running (or hibernating) when you install NI ExpressCard module, you must reboot to detect the PXI system. Otherwise, the PXI system is detected when you start your computer.

Figure 2-2 shows how to insert the NI ExpressCard module and connect the cable.

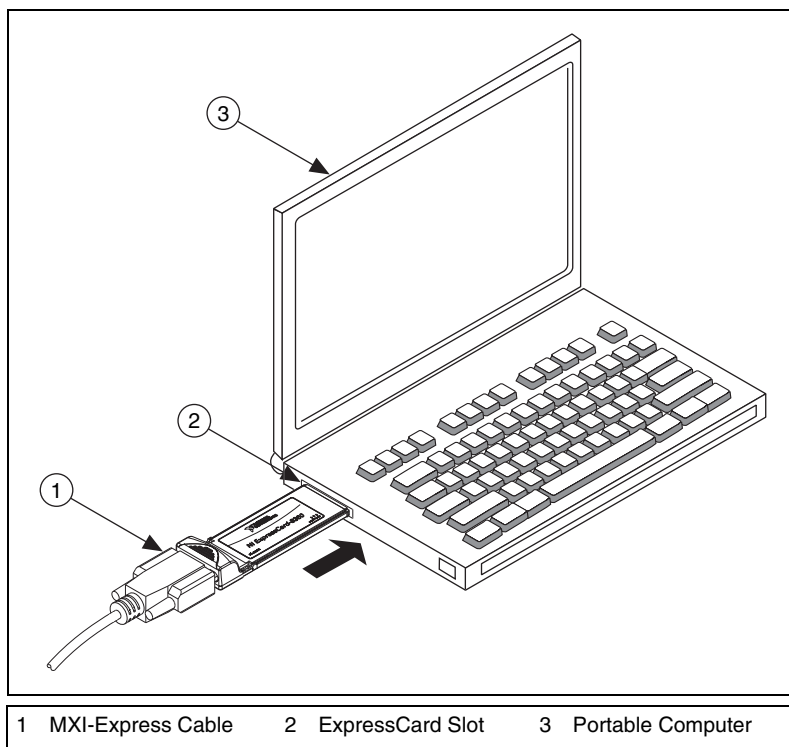

**Figure 2-2.** Installing the NI ExpressCard Module



## Installing an NI PCI Express Host Card

The following steps detail the process of installing an NI PCI Express host card. Refer to Figure 2-3 to assist you in completing this procedure.

1. Power off your computer, but leave it plugged in while installing the NI PCI Express host card. The power cord grounds the chassis and protects it from electrical damage while you install the card.



**Caution** To protect both yourself and the computer from electrical hazards, your computer should remain off until you finish installing the NI PCI Express host card.

2. Remove the top cover or access port to the PCI Express bus.
3. Select any available PCI Express expansion slot (x1 or wider).



**Note** The BIOS or motherboard may not support the NI PCI Express host card in a slot intended for a graphics card.

4. Locate the metal bracket that covers the cut-out in the back panel of the computer for the slot you have selected. Remove and save the bracket-retaining screw and the bracket cover.
5. Touch the metal part of the power supply case inside the computer to discharge any static electricity that might be on your clothes or body.
6. Line up the NI PCI Express host card with the slot on the back panel. Slowly push down on the top of the NI PCI Express host card until its card-edge connector is resting on the expansion slot receptacle. Using slow, evenly distributed pressure, press the NI PCI Express host card straight down until it seats in the expansion slot.
7. Reinstall the bracket-retaining screw to secure the NI PCI Express host card to the back panel rail.
8. Replace the computer cover.

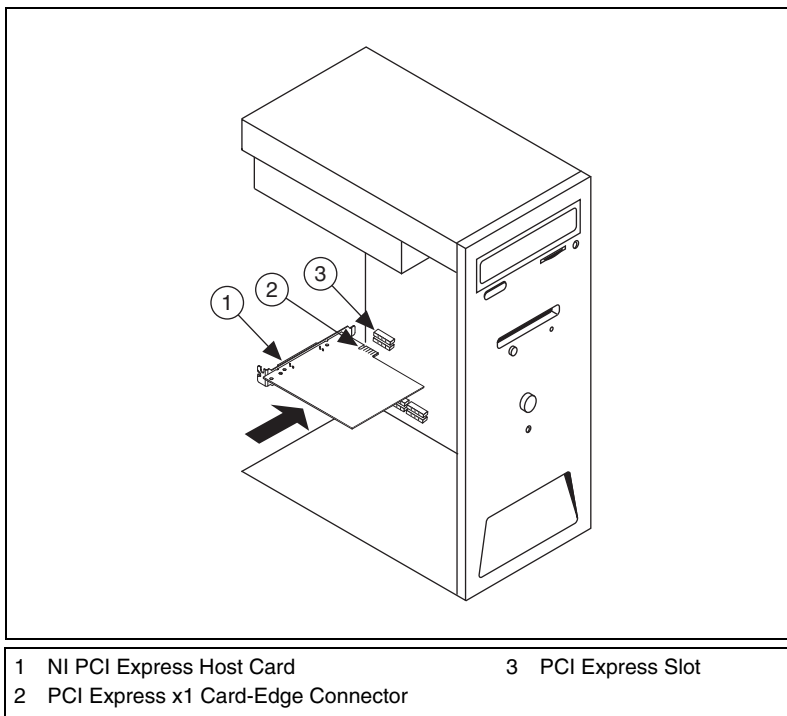

**Figure 2-3.** Installing the NI PCI Express Host Card

Figure 2-4 shows the cable connection with which a PCI Express host card controls the NI PXI-1033 chassis.

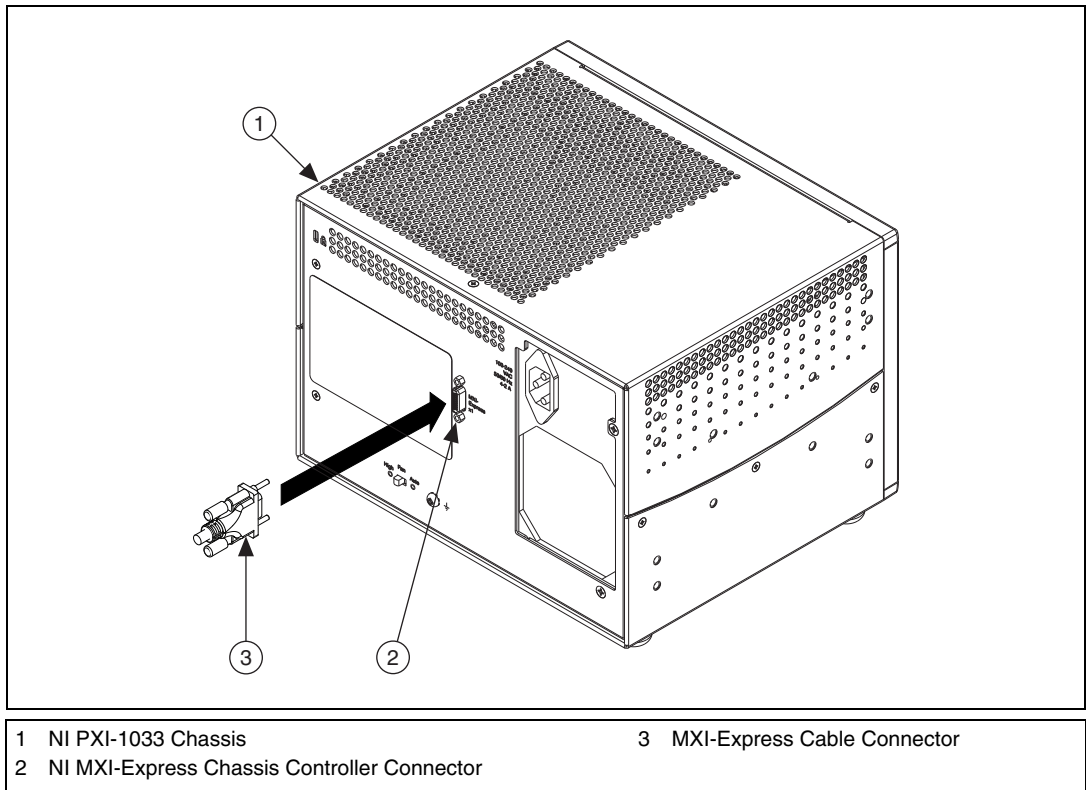

**Figure 2-4.** NI PCI Express Host Card Cable Connection

## Cabling

1. Connect the appropriate MXI-Express cable to the NI PCI Express card and NI PXI-1033 chassis. The cables have no polarity, so either end may be connected to either connector.



**Caution** Do *not* remove the cable after the system is powered on. Doing so can hang or cause errors in applications communicating with devices behind MXI-Express. If a cable becomes unplugged, plug it back into the system.



**Note** For more information about cables, refer to the [MXI-Express Cable Options](#) section of this chapter.

## Powering Up the MXI-Express System

1. Power on the chassis.
2. Power on the host.

Typical PCI-PCI bridges are used to add PCI devices to a PCI hierarchy in which all the bridges and devices are contained within a single chassis. Because of this, BIOSes and operating systems make the assumption that all PCI devices in the entire hierarchy will be available as soon as code execution begins at power-up time. This assumption means that all of the expansion chassis must be turned on before the host PC for the BIOS and OS to correctly configure a MXI-Express system.



**Notes** You may add additional chassis using MXI-3 or MXI-4. When using MXI-4, there are no restrictions on chassis power-on order, except that the host must be powered on last. When using MXI-3, you must power up the chassis in order, beginning furthest from the host and ending with the host. Refer to the MXI-3 or MXI-4 documentation for further details.

The NI PXI-1033 chassis will assert a wake signal on power up. The host PC also will power on if it supports this functionality.

## Powering Down the MXI-Express System

Because operating systems and drivers commonly make the assumption that PCI devices will be present in the system from power-up to power-down, it is important not to power off the expansion chassis until after the host PC is powered off. Powering off the expansion chassis while the host is still on can cause crashes or hangs. The order in which expansion chassis are powered off, relative to each other, is not important.

## Checking LEDs for Status

After powering on the NI PXI-1033 chassis you should check the LEDs for status to ensure that all connected systems have linked. The following table defines the LED states.

**Table 2-1.** LED Status for the NI PXI-1033 Chassis

LED	Color	Meaning
PWR	Off	No power
	Green	Power is within spec
	Red	Power is out of spec
LINK	Off	Link not established
	Green	Link established
	Alternating Green and Red	Link established and activity present on the PCI bus
	Red	Link corrupted due to MXI sideband signals
	Blinking Red	Link corrupted due to missing PCI Express Reference Clock

## Functional Overview

MXI-Express is based on PCI Express technology. A MXI-Express kit uses a PCI Express switch and PCI Express-to-PCI bridge to enable control of a PXI or CompactPCI chassis from a PC with an available PCI Express slot. The PCI Express-to-PCI bridge architecture is transparent to device drivers, so no additional software is needed to support using PXI and CompactPCI devices in a chassis connected using MXI-Express.

The link between the PC and the chassis is a x1 cabled PCI Express link. This link is a dual-simplex communication channel comprised of a low-voltage, differentially driven signal pair. The link can transmit at a rate of 2.5 Gbps in each direction simultaneously.

## MXI-Express Cable Options

---

MXI-Express is available with cables of various lengths. Table 2-2 shows the cables available from National Instruments.

**Table 2-2.** National Instruments MXI-Express Cables

Cable Length (Meters)	Description
1 m	MXI-Express copper cable
3 m	MXI-Express copper cable
7 m	MXI-Express copper cable

## Installing PXI Modules

---

Complete the following steps to install a module.

1. Make sure the power switch is in the Off (Standby) position.
2. Install a module into a chassis slot by first placing the module card edges into the front module guides (top and bottom), as shown in Figure 2-5. Slide the module to the rear of the chassis, making sure that the injector/ejector handle is pushed down as shown in Figure 2-5.
3. When you begin to feel resistance, push up on the injector/ejector handle to fully inject the module into the chassis frame. Secure the module front panel to the chassis using the module front-panel mounting screws.



**Note** You must install the driver software provided on the NI Driver CD supplied with your kit before you can use the modules in the chassis.

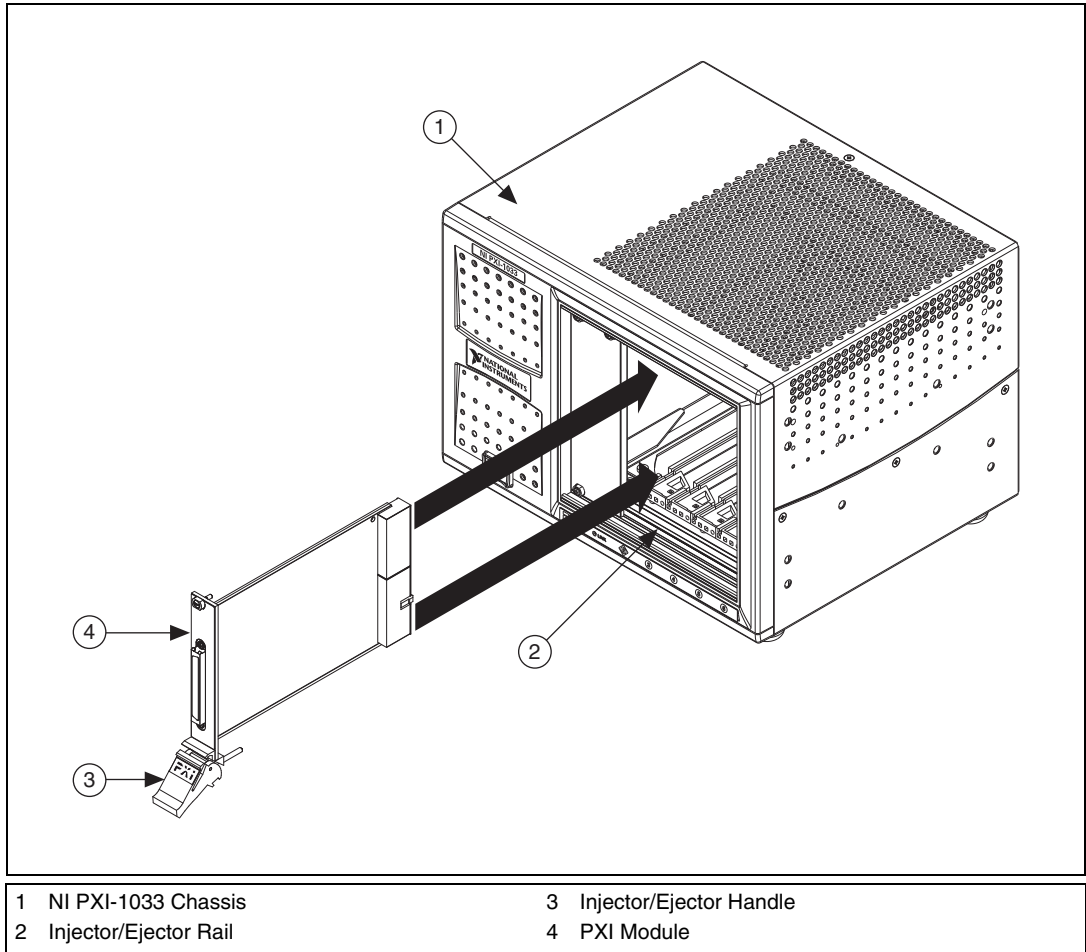

Figure 2-5. Installing PXI or CompactPCI Modules

## PXI System Configuration with MAX

Configuration of the PXI system is handled through Measurement & Automation Explorer (MAX), included on the NI Driver CD-ROM packaged with your kit. MAX creates the `pxisys.ini` file that defines the layout and parameters of your PXI system. After installing the software on the NI Driver CD-ROM, the MAX icon will be present on the desktop. The configuration steps for single or multiple chassis systems are the same.

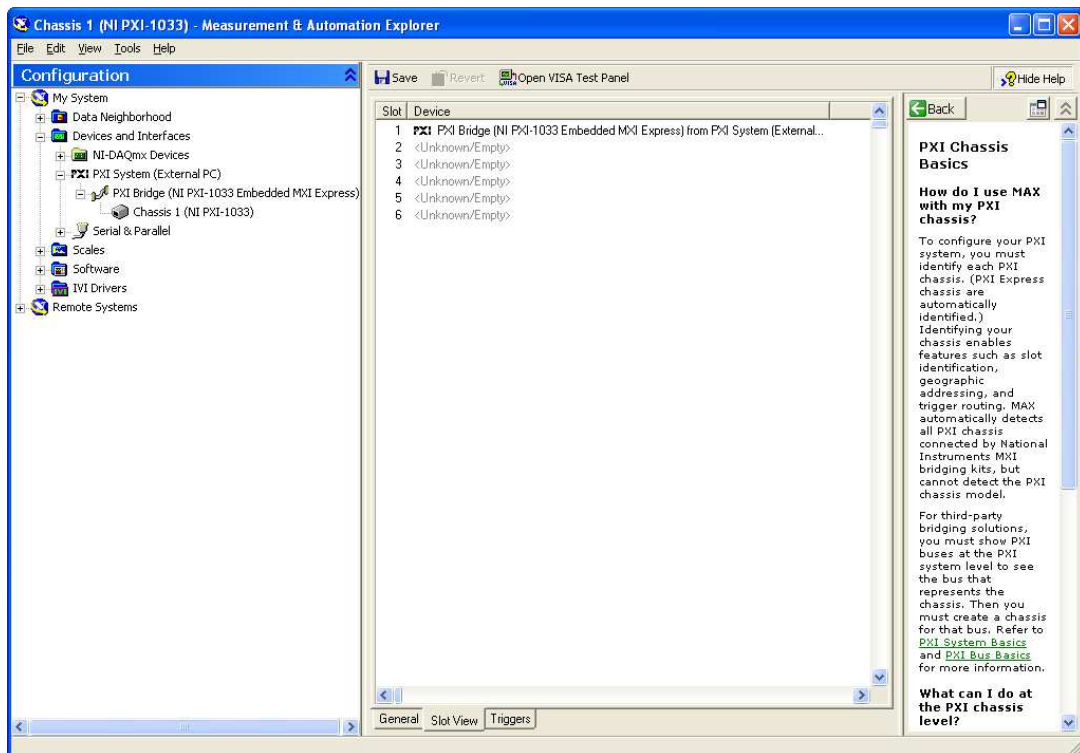

Figure 2-6. Chassis Configuration in MAX

## Basic PXI System Configuration

The *Platform Services 2.1* (or higher) software provided on the NI Driver CD-ROM will automatically detect your NI PXI-1033 chassis. To manually configure your chassis follow the steps outlined below. Refer to Figure 2-6 while completing the following steps:

1. Launch MAX.
2. In the **Configuration** tree, click the **Devices and Interfaces** branch to expand it.
3. If the PXI system controller has not yet been configured, it will be labeled **PXI System (Unidentified)**. Right-click this entry to display the context menu and then select the appropriate controller model from the **Identify As** submenu.



4. Click the **PXI System** controller, and the chassis (or multiple chassis, in a multi-chassis configuration) will be listed below it. Identify each chassis by right-clicking its entry and then selecting **External PC** through the **Identify As** submenu. Further expanding the **PXI System** branch will show all of the devices in the system that can be recognized by NI-VISA. After your controller and all of your chassis have been identified, the required `pxisys.ini` file will be complete.
5. Apply the chassis number labels (shown in Figure 2-7) included with your kit to each chassis in your PXI system, and write in the chassis number accordingly in the white space.



Figure 2-7. Chassis Number Label

## Trigger Configuration in MAX

Each chassis has one or more trigger buses, each with eight lines numbered 0 through 7 that can be reserved and routed statically or dynamically. Static reservation “pre-allocates” a trigger line to prevent its configuration by a user program. Dynamic reservation/routing/deallocation is performed *on the fly* within a user program based upon National Instruments APIs such as NI-DAQmx. Static reservation of trigger lines can be implemented by the user in MAX through the **Triggers** tab. Reserved trigger lines will not be used by PXI modules dynamically configured by programs such as NI-DAQmx. This prevents the instruments from double-driving the trigger lines, possibly damaging devices in the chassis.

Complete the following steps to reserve these trigger lines in MAX.

1. In the **Configuration** tree, click the PXI chassis branch you want to configure.
2. Click the **Triggers** tab at the bottom of the right-hand pane.
3. Select which trigger lines you want to statically reserve.
4. Click the **Apply** button.



**Note** For more information about routing and reserving PXI triggers refer to KnowledgeBase **3TJDOND8** at [ni.com/support](http://ni.com/support).

## Using System Configuration and Initialization Files

---

The PXI specification allows many combinations of PXI chassis and system modules. To assist system integrators, the manufacturers of PXI chassis and system modules must document the capabilities of their products. The minimum documentation requirements are contained in `.ini` files, which consist of ASCII text. System integrators, configuration utilities, and device drivers can use these `.ini` files.

The capability documentation for the NI PXI-1033 chassis is contained in the `chassis.ini` file on the software media that comes with the chassis. The information in this file is combined with information about the system controller to create a single system initialization file called `pxisys.ini` (PXI System Initialization). The system controller manufacturer either provides a `pxisys.ini` file for the particular chassis model that contains the system controller or provides a utility that can read an arbitrary `chassis.ini` file and generate the corresponding `pxisys.ini` file. System controllers from National Instruments use MAX to generate the `pxisys.ini` file from the `chassis.ini` file.

Device drivers and other utility software read the `pxisys.ini` file to obtain system information. Device drivers should have no need to directly read the `chassis.ini` file. For detailed information regarding initialization files, refer to the PXI specification at [www.pxisa.org](http://www.pxisa.org).

---

# Maintenance

This chapter describes basic maintenance procedures you can perform on the NI PXI-1033 chassis.



**Caution** Disconnect the power cables prior to servicing the chassis.

---

## Service Interval

Clean the chassis fan filter at a maximum interval of six months. Depending on the amount of use and ambient dust levels in the operating environment, the filter may require more frequent cleaning.

Clean dust from the chassis exterior (and interior) as needed, based on the operating environment. Periodic cleaning increases reliability.

---

## Preparation

The information in this chapter is designed for use by qualified service personnel. Read the *Read Me First: Safety and Radio-Frequency Interference* document included with your kit before attempting any procedures in this chapter.



**Caution** Many components within the chassis are susceptible to static discharge damage. Service the chassis only in a static-free environment. Observe standard handling precautions for static-sensitive devices while servicing the chassis. Always wear a grounded wrist strap or equivalent while servicing the chassis.

---

## Cleaning



**Caution** Always disconnect the AC power cable before cleaning or servicing the chassis.

Cleaning procedures consist of exterior and interior cleaning of the chassis and cleaning the fan filter. Refer to your module user documentation for information on cleaning individual CompactPCI or PXI modules.

## Interior Cleaning

Use a dry, low-velocity stream of air to clean the interior of the chassis.  
Use a soft-bristle brush for cleaning around components.

## Exterior Cleaning



**Cautions** Avoid getting moisture inside the chassis during exterior cleaning, especially through the top vents. Use just enough moisture to dampen the cloth.

Do *not* wash the front- or rear-panel connectors or switches. Cover these components while cleaning the chassis.

Do *not* use harsh chemical cleaning agents; they may damage the chassis. Avoid chemicals that contain benzene, toluene, xylene, acetone, or similar solvents.

Clean the exterior surfaces of the chassis with a dry lint-free cloth or a soft-bristle brush. If any dirt remains, wipe with a cloth moistened in a mild soap solution. Remove any soap residue by wiping with a cloth moistened with clear water. Do *not* use abrasive compounds on any part of the chassis.

## Cleaning and Replacing the Fan Filter

---

A dirty fan filter can dramatically reduce the cooling performance of the chassis. Clean the filter whenever it becomes visibly dirty. You can easily remove the chassis air filter from the bottom of the chassis by removing the filter cover. To remove the filter cover, loosen the retainer screw. The filter cover is shown in Figure 1-3, *Bottom View of the NI PXI-1033 Chassis*.

Clean the fan filter by washing it in a mild soap solution and then vacuuming or blowing air through it. Rinse the filter with water and allow it to dry before reinstalling it on the chassis.

You can replace the fan filter with part number 150139-C from Air Filtration Products, Inc., Tucson, AZ 85705, if necessary.

---

## Specifications



**Caution** If the NI PXI-1033 chassis is used in a manner inconsistent with the instructions or specifications listed by National Instruments, the protective features of the chassis may be impaired.



**Note** Specifications are subject to change without notice.

This appendix contains specifications for the NI PXI-1033 chassis.

### Electrical

#### AC Input

Input voltage range.....	100–240 VAC
Operating voltage range <sup>1</sup> .....	90–264 VAC
Input frequency .....	50/60 Hz
Operating frequency range <sup>1</sup> .....	47–63 Hz
Input current rating.....	4–2 A
Efficiency .....	>70% at full load, normal input voltage
Power disconnect .....	The AC power cable provides main power disconnect. The front-panel power switch controls the internal chassis power supply that provides DC power to the CompactPCI/PXI backplane.

---

<sup>1</sup> The operating range is guaranteed by design.

## DC Output

DC current capacity ( $I_{MP}$ )

Voltage	0–50 °C
+3.3 V	10 A
+5 V	15 A
+12 V	2.5 A
–12 V	0.8 A

Over-current protection .....All outputs protected from short circuit

Over-voltage protection

Over-voltage at	Active Range	
	Minimum	Maximum
+3.3 V	3.76 V	4.3 V
+5 V	5.74 V	7.0 V
+12 V	13.4 V	15.6 V

## Chassis Cooling

Per slot cooling capacity.....25 W

Slot airflow direction .....P1 to P2, bottom of module to top of module

Module cooling

System .....Forced air circulation (positive pressurization) through a 101.1 CFM fan with High/Auto speed selector

Intake .....Bottom of chassis

Exhaust .....Along rear, right side, and top of chassis

Power supply cooling	
System.....	Forced air circulation through integrated fan
Intake .....	Front side of chassis
Exhaust.....	Rear side of chassis

## Environmental

Maximum altitude ..... 2,000 m (800 mbar)  
(at 25 °C ambient)

Measurement Category ..... II

Pollution Degree ..... 2

For indoor use only.

## Operating Environment

Ambient temperature range..... 0 to 50 °C  
(Tested in accordance with IEC-60068-2-1 and IEC-60068-2-2. Meets MIL-PRF-28800F Class 3 low temperature limit and high temperature limit.)

Relative humidity range ..... 20 to 80%, noncondensing  
(Tested in accordance with IEC-60068-2-56.)

## Storage Environment

Ambient temperature range..... -40 to 85 °C  
(Tested in accordance with IEC-60068-2-1 and IEC-60068-2-2. Meets MIL-PRF-28800F Class 3 limits.)

Relative humidity range ..... 10 to 95%, noncondensing  
(Tested in accordance with IEC-60068-2-56.)

## Shock and Vibration

Operational shock .....20 g peak, half-sine, 11 ms pulse  
(Tested in accordance with  
IEC-60068-2-27. Meets  
MIL-PRF-28800F Class 2 limits.)

## Random Vibration

Operating .....5 to 500 Hz, 0.3 g<sub>rms</sub>

Nonoperating .....5 to 500 Hz, 2.4 g<sub>rms</sub>  
(Tested in accordance with  
IEC-60068-2-64. Nonoperating  
test profile exceeds the  
requirements of  
MIL-PRF-28800F, Class 3.)

## Acoustic Emissions

### Sound Pressure Level (at Operator Position)

Tested in accordance with ISO 7779. Meets MIL-PRF-28800F requirements.

NI PXI-1033

Auto fan (at 25 °C ambient) .....37.4 dBA

High fan .....51.5 dBA

### Sound Power

Tested in accordance with ISO 7779.

NI PXI-1033

Auto fan (at 25 °C ambient) .....43.8 dBA

High fan .....60.9 dBA



## Safety

This product is designed to meet the requirements of the following standards of safety for information technology equipment:

- IEC 61010-1, EN 61010-1
- UL 61010-1, CSA 61010-1



**Note** For UL and other safety certifications, refer to the product label or the [Online Product Certification](#) section.

## Electromagnetic Compatibility

This product meets the requirements of the following EMC standards for electrical equipment for measurement, control, and laboratory use:

- EN 61326-1 (IEC 61326-1): Class A emissions; Basic immunity
- EN 55011 (CISPR 11): Group 1, Class A emissions
- AS/NZS CISPR 11: Group 1, Class A emissions
- FCC 47 CFR Part 15B: Class A emissions
- ICES-001: Class A emissions



**Note** In the United States (per FCC 47 CFR), Class A equipment is intended for use in commercial, light-industrial, and heavy-industrial locations. In Europe, Canada, Australia and New Zealand (per CISPR 11) Class A equipment is intended for use only in heavy-industrial locations.



**Note** Group 1 equipment (per CISPR 11) is any industrial, scientific, or medical equipment that does not intentionally generate radio frequency energy for the treatment of material or inspection/analysis purposes.



**Note** For EMC declarations and certifications, and additional information, refer to the [Online Product Certification](#) section.

## CE Compliance

This product meets the essential requirements of applicable European Directives as follows:

- 2006/95/EC; Low-Voltage Directive (safety)
- 2004/108/EC; Electromagnetic Compatibility Directive (EMC)

## Online Product Certification

To obtain product certifications and the Declaration of Conformity (DoC) for this product, visit [ni.com/certification](http://ni.com/certification), search by model number or product line, and click the appropriate link in the Certification column.

## Environmental Management

NI is committed to designing and manufacturing products in an environmentally responsible manner. NI recognizes that eliminating certain hazardous substances from our products is beneficial to the environment and to NI customers.

For additional environmental information, refer to the *NI and the Environment* Web page at [ni.com/environment](http://ni.com/environment). This page contains the environmental regulations and directives with which NI complies, as well as other environmental information not included in this document.

### Waste Electrical and Electronic Equipment (WEEE)



**EU Customers** At the end of the product life cycle, all products must be sent to a WEEE recycling center. For more information about WEEE recycling centers, National Instruments WEEE initiatives, and compliance with WEEE Directive 2002/96/EC on Waste Electrical and Electronic Equipment, visit [ni.com/environment/weee](http://ni.com/environment/weee).

### 电子信息产品污染控制管理办法（中国 RoHS）



**中国客户** National Instruments 符合中国电子信息产品中限制使用某些有害物质指令 (RoHS)。关于 National Instruments 中国 RoHS 合规性信息，请登录 [ni.com/environment/rohs\\_china](http://ni.com/environment/rohs_china)。(For information about China RoHS compliance, go to [ni.com/environment/rohs\\_china](http://ni.com/environment/rohs_china).)

## Backplane

Size .....3U-sized; integrated controller and 5 peripheral slots.  
 Compliant with IEEE 1101.10 mechanical packaging.  
*PXI Hardware Specification, Revision 2.2* compliant. Accepts both PXI and CompactPCI 3U modules.

V(I/O)<sup>1</sup> .....+5 V

<sup>1</sup> V(I/O) is connected to the +5 V DC power plane, so the same specifications apply to V(I/O) and +5 V.

Backplane bare-board material .....	UL 94 V-0 recognized
Backplane connectors .....	Conform to IEC 917 and IEC 1076-4-101, and are UL 94 V-0 rated

## 10 MHz System Reference Clock (10 MHz REF)

Maximum clock skew between slots .....	250 ps
Built-in 10 MHz clock Accuracy .....	$\pm 25$ ppm (guaranteed over the operating temperature range)

## DMA Support

For more information about this chassis' support of hardware modules with 64-bit DMA and/or 32-bit DMA with PAE mode, please visit [ni.com/info](http://ni.com/info) and enter the Info Code `PXI64HANG`.

## Mechanical

Overall dimensions (standard chassis) Height.....	177 mm (6.97 in.)
--	-------------------



**Note** 12.7 mm (0.50 in.) is added to height when feet are installed.

Width .....	257.1 mm (10.12 in.)
Depth.....	212.8 mm (8.38 in.)
Weight.....	5 kg (11.0 lbs)
Chassis materials.....	Sheet Aluminum, Extruded Aluminum, Cold Rolled Steel, Nylon
Finish.....	Clear Chromate Conversion Coat on Aluminum Electrodeposited Nickel Plate Plate on Cold Rolled Steel Polyester Urethane Powder Paint

Figure A-1 and Figure A-2 show the NI PXI-1033 dimensions. The holes shown are for the installation of the optional rack-mount kits as shown in Figure A-3. Notice that the front and rear rack mounting holes (size M4) are symmetrical.

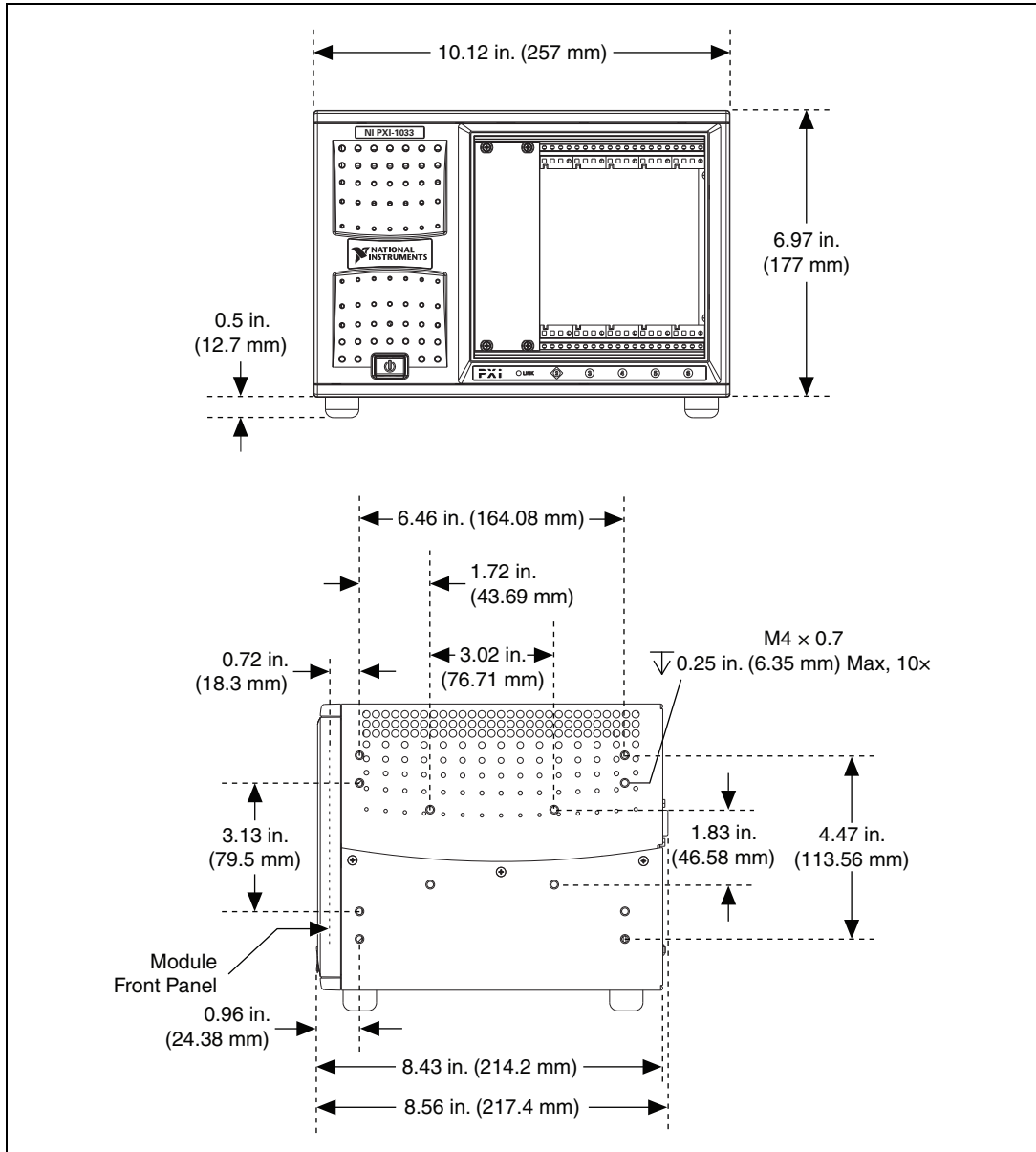
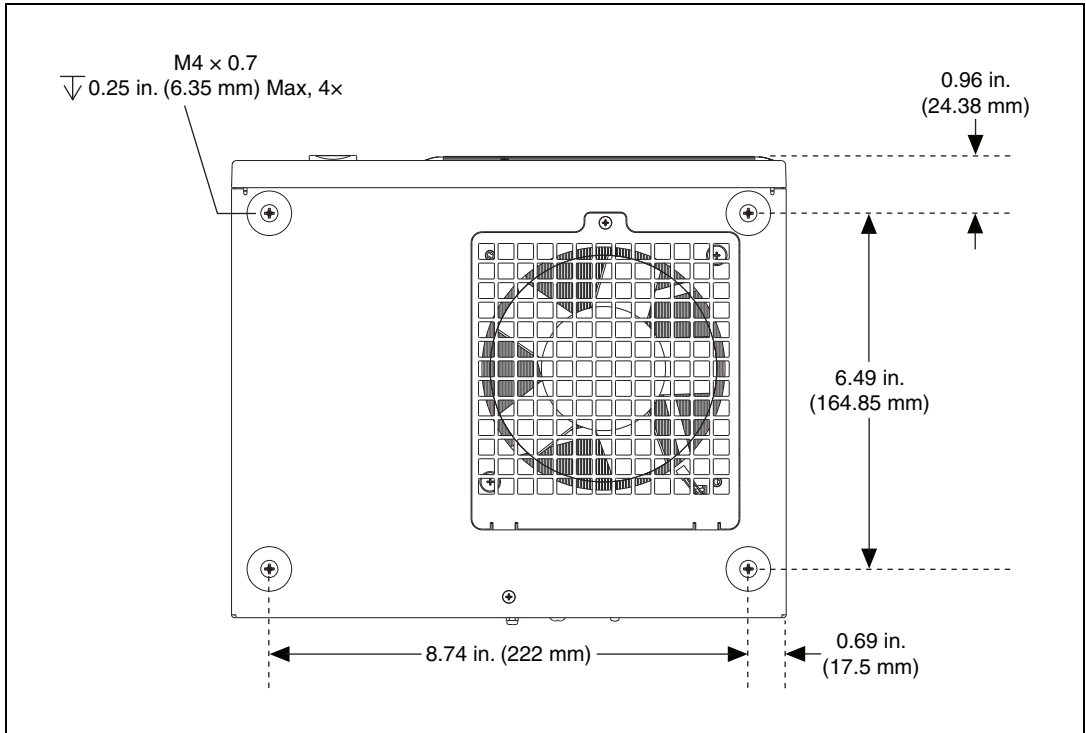
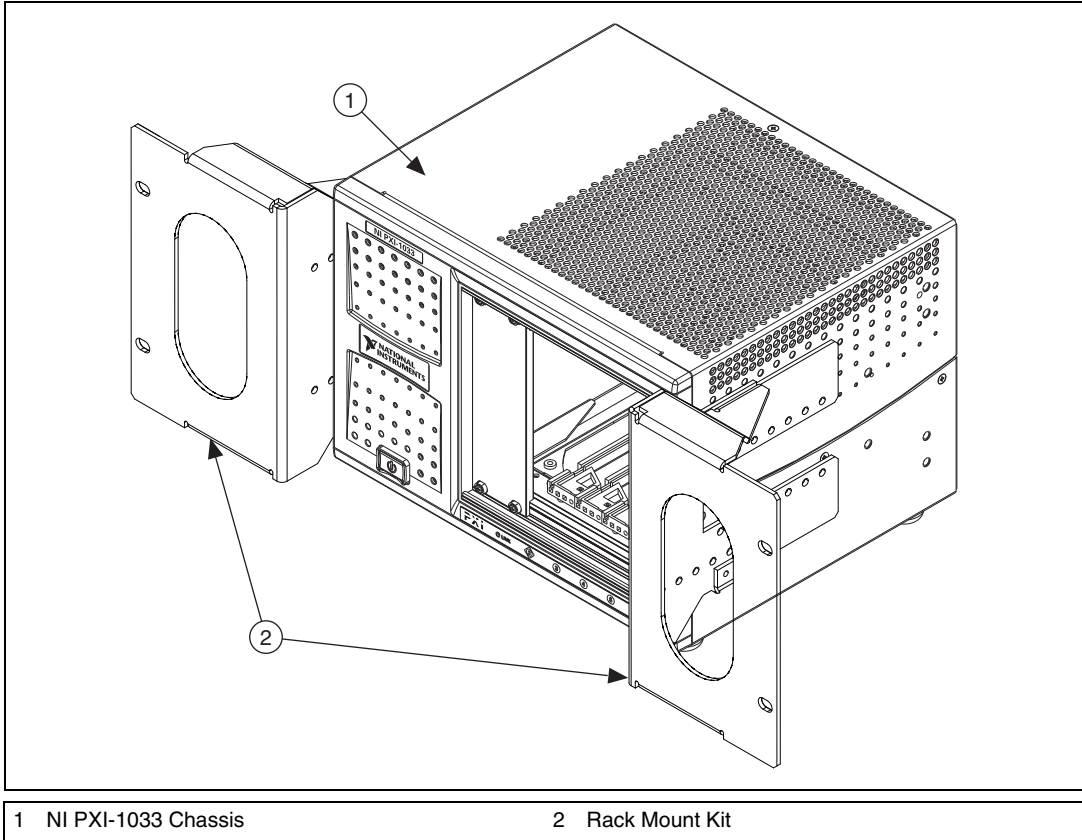

Figure A-1. NI PXI-1033 Dimensions (Front and Side)



**Figure A-2.** NI PXI-1033 Dimensions (Bottom)

Figure A-3 shows the NI PXI-1033 rack mount kit components.



**Figure A-3.** NI PXI-1033 Rack Mount Kit Components

---

## Pinouts

This appendix describes the P1 and P2 connector pinouts for the NI PXI-1033/NI PXI-1033 backplane.

Table B-1 shows the P1 (J1) Connector Pinout for the star trigger slot.

Table B-2 shows the P2 (J2) Connector Pinout for the star trigger slot.

Table B-3 shows the P1 (J1) Connector Pinout for the peripheral slots.

Table B-4 shows the P2 (J2) Connector Pinout for the peripheral slots.



**Note** PXI signals are shown in bold.

**Table B-1.** P1 (J1) Connector Pinout for the Star Trigger Slot

Pin	Z	A	B	C	D	E	F
25	GND	5V	REQ64#	ENUM#	3.3V	5V	GND
24	GND	AD[1]	5V	V(I/O)	AD[0]	ACK64#	GND
23	GND	3.3V	AD[4]	AD[3]	5V	AD[2]	GND
22	GND	AD[7]	GND	3.3V	AD[6]	AD[5]	GND
21	GND	3.3V	AD[9]	AD[8]	M66EN	C/BE[0]#	GND
20	GND	AD[12]	GND	V(I/O)	AD[11]	AD[10]	GND
19	GND	3.3V	AD[15]	AD[14]	GND	AD[13]	GND
18	GND	SERR#	GND	3.3V	PAR	C/BE[1]#	GND
17	GND	3.3V	IPMB_SCL	IPMB_SDA	GND	PERR#	GND
16	GND	DEVSEL#	GND	V(I/O)	STOP#	LOCK#	GND
15	GND	3.3V	FRAME#	IRDY#	BD_SEL#	TRDY#	GND
12–14	Key Area						
11	GND	AD[18]	AD[17]	AD[16]	GND	C/BE[2]#	GND
10	GND	AD[21]	GND	3.3V	AD[20]	AD[19]	GND
9	GND	C/BE[3]#	IDSEL	AD[23]	GND	AD[22]	GND
8	GND	AD[26]	GND	V(I/O)	AD[25]	AD[24]	GND
7	GND	AD[30]	AD[29]	AD[28]	GND	AD[27]	GND
6	GND	REQ#	GND	3.3V	CLK	AD[31]	GND
5	GND	BRSVP1A5	BRSVP1B5	RST#	GND	GNT#	GND
4	GND	IPMB_PWR	HEALTHY#	V(I/O)	INTP	INTS	GND
3	GND	INTA#	INTB#	INTC#	5V	INTD#	GND
2	GND	TCK	5V	TMS	TDO	TDI	GND
1	GND	5V	-12V	TRST#	+12V	5V	GND



**Table B-2.** P2 (J2) Connector Pinout for the Star Trigger Slot

Pin	Z	A	B	C	D	E	F
22	GND	GA4	GA3	GA2	GA1	GA0	GND
21	GND	<b>PXI_LBR0</b>	RSV	<b>PXI_LBR1</b>	<b>PXI_LBR2</b>	<b>PXI_LBR3</b>	GND
20	GND	<b>PXI_LBR4</b>	<b>PXI_LBR5</b>	<b>PXI_STAR0</b>	GND	<b>PXI_STAR1</b>	GND
19	GND	<b>PXI_STAR2</b>	RSV	<b>PXI_STAR3</b>	<b>PXI_STAR4</b>	<b>PXI_STAR5</b>	GND
18	GND	<b>PXI_TRIG3</b>	<b>PXI_TRIG4</b>	<b>PXI_TRIG5</b>	GND	<b>PXI_TRIG6</b>	GND
17	GND	<b>PXI_TRIG2</b>	GND	RSV	<b>PXI_CLK10_IN</b>	<b>PXI_CLK10</b>	GND
16	GND	<b>PXI_TRIG1</b>	<b>PXI_TRIG0</b>	RSV	GND	<b>PXI_TRIG7</b>	GND
15	GND	<b>PXI_BRSVA15</b>	GND	RSV	<b>PXI_STAR6</b>	<b>PXI_LBR6</b>	GND
14	GND	RSV	RSV	RSV	GND	RSV	GND
13	GND	RSV	GND	V(I/O)	RSV	RSV	GND
12	GND	RSV	RSV	RSV	GND	RSV	GND
11	GND	RSV	GND	V(I/O)	RSV	RSV	GND
10	GND	RSV	RSV	RSV	GND	RSV	GND
9	GND	RSV	GND	V(I/O)	RSV	RSV	GND
8	GND	RSV	RSV	RSV	GND	RSV	GND
7	GND	RSV	GND	V(I/O)	RSV	RSV	GND
6	GND	RSV	RSV	RSV	GND	RSV	GND
5	GND	RSV	GND	V(I/O)	RSV	RSV	GND
4	GND	V(I/O)	<b>PXI_BRSVB4</b>	RSV	GND	RSV	GND
3	GND	<b>PXI_LBR7</b>	GND	<b>PXI_LBR8</b>	<b>PXI_LBR9</b>	<b>PXI_LBR10</b>	GND
2	GND	<b>PXI_LBR11</b>	<b>PXI_LBR12</b>	UNC	<b>PXI_STAR7</b>	<b>PXI_STAR8</b>	GND
1	GND	<b>PXI_STAR9</b>	GND	<b>PXI_STAR10</b>	<b>PXI_STAR11</b>	<b>PXI_STAR12</b>	GND

**Table B-3.** P1 (J1) Connector Pinout for the Generic Peripheral Slot

Pin	Z	A	B	C	D	E	F
25	GND	5V	REQ64#	ENUM#	3.3V	5V	GND
24	GND	AD[1]	5V	V(I/O)	AD[0]	ACK64#	GND
23	GND	3.3V	AD[4]	AD[3]	5V	AD[2]	GND
22	GND	AD[7]	GND	3.3V	AD[6]	AD[5]	GND
21	GND	3.3V	AD[9]	AD[8]	M66EN	C/BE[0]#	GND
20	GND	AD[12]	GND	V(I/O)	AD[11]	AD[10]	GND
19	GND	3.3V	AD[15]	AD[14]	GND	AD[13]	GND
18	GND	SERR#	GND	3.3V	PAR	C/BE[1]#	GND
17	GND	3.3V	IPMB_SCL	IPMB_SDA	GND	PERR#	GND
16	GND	DEVSEL#	GND	V(I/O)	STOP#	LOCK#	GND
15	GND	3.3V	FRAME#	IRDY#	BD_SEL#	TRDY#	GND
12–14	Key Area						
11	GND	AD[18]	AD[17]	AD[16]	GND	C/BE[2]#	GND
10	GND	AD[21]	GND	3.3V	AD[20]	AD[19]	GND
9	GND	C/BE[3]#	IDSEL	AD[23]	GND	AD[22]	GND
8	GND	AD[26]	GND	V(I/O)	AD[25]	AD[24]	GND
7	GND	AD[30]	AD[29]	AD[28]	GND	AD[27]	GND
6	GND	REQ#	GND	3.3V	CLK	AD[31]	GND
5	GND	BRSVP1A5	BRSVP1B5	RST#	GND	GNT#	GND
4	GND	IPMB_PWR	HEALTHY#	V(I/O)	INTP	INTS	GND
3	GND	INTA#	INTB#	INTC#	5V	INTD#	GND
2	GND	TCK	5V	TMS	TDO	TDI	GND
1	GND	5V	-12V	TRST#	+12V	5V	GND

**Table B-4.** P2 (J2) Connector Pinout for the Generic Peripheral Slot

Pin	Z	A	B	C	D	E	F
22	GND	GA4	GA3	GA2	GA1	GA0	GND
21	GND	<b>PXI_LBR0</b>	RSV	<b>PXI_LBR1</b>	<b>PXI_LBR2</b>	<b>PXI_LBR3</b>	GND
20	GND	<b>PXI_LBR4</b>	<b>PXI_LBR5</b>	<b>PXI_LBL0</b>	GND	<b>PXI_LBL1</b>	GND
19	GND	<b>PXI_LBL2</b>	RSV	<b>PXI_LBL3</b>	<b>PXI_LBL4</b>	<b>PXI_LBL5</b>	GND
18	GND	<b>PXI_TRIG3</b>	<b>PXI_TRIG4</b>	<b>PXI_TRIG5</b>	GND	<b>PXI_TRIG6</b>	GND
17	GND	<b>PXI_TRIG2</b>	GND	RSV	<b>PXI_STAR</b>	<b>PXI_CLK10</b>	GND
16	GND	<b>PXI_TRIG1</b>	<b>PXI_TRIG0</b>	RSV	GND	<b>PXI_TRIG7</b>	GND
15	GND	<b>PXI_BRSVA15</b>	GND	RSV	<b>PXI_LBL6</b>	<b>PXI_LBR6</b>	GND
14	GND	RSV	RSV	RSV	GND	RSV	GND
13	GND	RSV	GND	V(I/O)	RSV	RSV	GND
12	GND	RSV	RSV	RSV	GND	RSV	GND
11	GND	RSV	GND	V(I/O)	RSV	RSV	GND
10	GND	RSV	RSV	RSV	GND	RSV	GND
9	GND	RSV	GND	V(I/O)	RSV	RSV	GND
8	GND	RSV	RSV	RSV	GND	RSV	GND
7	GND	RSV	GND	V(I/O)	RSV	RSV	GND
6	GND	RSV	RSV	RSV	GND	RSV	GND
5	GND	RSV	GND	V(I/O)	RSV	RSV	GND
4	GND	V(I/O)	64EN#	RSV	GND	RSV	GND
3	GND	<b>PXI_LBR7</b>	GND	<b>PXI_LBR8</b>	<b>PXI_LBR9</b>	<b>PXI_LBR10</b>	GND
2	GND	<b>PXI_LBR11</b>	<b>PXI_LBR12</b>	UNC	<b>PXI_LBL7</b>	<b>PXI_LBL8</b>	GND
1	GND	<b>PXI_LBL9</b>	GND	<b>PXI_LBL10</b>	<b>PXI_LBL11</b>	<b>PXI_LBL12</b>	GND



---

# Technical Support and Professional Services

Log in to your National Instruments [ni.com](http://ni.com) User Profile to get personalized access to your services. Visit the following sections of [ni.com](http://ni.com) for technical support and professional services:

- **Support**—Technical support at [ni.com/support](http://ni.com/support) includes the following resources:
  - **Self-Help Technical Resources**—For answers and solutions, visit [ni.com/support](http://ni.com/support) for software drivers and updates, a searchable KnowledgeBase, product manuals, step-by-step troubleshooting wizards, thousands of example programs, tutorials, application notes, instrument drivers, and so on. Registered users also receive access to the NI Discussion Forums at [ni.com/forums](http://ni.com/forums). NI Applications Engineers make sure every question submitted online receives an answer.
  - **Standard Service Program Membership**—This program entitles members to direct access to NI Applications Engineers via phone and email for one-to-one technical support, as well as exclusive access to eLearning training modules at [ni.com/elearning](http://ni.com/elearning). All customers automatically receive a one-year membership in the Standard Service Program (SSP) with the purchase of most software products and bundles including NI Developer Suite. NI also offers flexible extended contract options that guarantee your SSP benefits are available without interruption for as long as you need them. Visit [ni.com/ssp](http://ni.com/ssp) for more information.

For information about other technical support options in your area, visit [ni.com/services](http://ni.com/services), or contact your local office at [ni.com/contact](http://ni.com/contact).

- **Training and Certification**—Visit [ni.com/training](http://ni.com/training) for training and certification program information. You can also register for instructor-led, hands-on courses at locations around the world.
- **System Integration**—If you have time constraints, limited in-house technical resources, or other project challenges, National Instruments

Alliance Partner members can help. To learn more, call your local NI office or visit [ni.com/alliance](http://ni.com/alliance).

- **Declaration of Conformity (DoC)**—A DoC is our claim of compliance with the Council of the European Communities using the manufacturer’s declaration of conformity. This system affords the user protection for electromagnetic compatibility (EMC) and product safety. You can obtain the DoC for your product by visiting [ni.com/certification](http://ni.com/certification).
- **Calibration Certificate**—If your product supports calibration, you can obtain the calibration certificate for your product at [ni.com/calibration](http://ni.com/calibration).

You also can visit the Worldwide Offices section of [ni.com/niglobal](http://ni.com/niglobal) to access the branch office Web sites, which provide up-to-date contact information, support phone numbers, email addresses, and current events.

# Glossary

---

Symbol	Prefix	Value
p	pico	$10^{-12}$
n	nano	$10^{-9}$
$\mu$	micro	$10^{-6}$
m	milli	$10^{-3}$
k	kilo	$10^3$
M	mega	$10^6$
G	giga	$10^9$
T	tera	$10^{12}$

## Symbols

°	Degrees
≥	Equal or greater than
≤	Equal or less than
%	Percent
Ω	Ohms

## A

A	Amperes
AC	Alternating current
ANSI	American National Standards Institute
AUTO	Automatic fan speed control
AWG	American Wire Gauge

## B

backplane An assembly, typically a printed circuit board, with connectors and signal paths that bus the connector pins

## C

C Celsius

cfm Cubic feet per minute

CFR Code of Federal Regulations

cm Centimeters

CompactPCI An adaptation of the Peripheral Component Interconnect (PCI) Specification 2.1 or later for industrial and/or embedded applications requiring a more robust mechanical form factor than desktop PCI. It uses industry standard mechanical components and high-performance connector technologies to provide an optimized system intended for rugged applications. It is electrically compatible with the PCI Specification, which enables low-cost PCI components to be utilized in a mechanical form factor suited for rugged environments.

CSA Canadian Standards Association

## D

daisy-chain A method of propagating signals along a bus, in which the devices are prioritized on the basis of their position on the bus

DC Direct current

DoC Declaration of Conformity

## E

efficiency Ratio of output power to input power, expressed as a percentage

EIA Electronic Industries Association

**embedded system controller** A module configured for installation in slot 1 of a PXI chassis. This device is unique in the PXI system in that it performs the system controller functions, including clock sourcing and arbitration for data transfers across the backplane. Installing such a device into any other slot can damage the device, the PXI backplane, or both.

**EMC** Electromagnetic Compatibility

**EMI** Electromagnetic Interference

## F

**FCC** Federal Communications Commission

**filler panel** A blank module front panel used to fill empty slots in the chassis

## G

**g** (1) grams; (2) a measure of acceleration approximately equal to  $9.8 \text{ m/s}^2$

**GPIB** General Purpose Interface Bus (IEEE 488)

**$g_{\text{rms}}$**  A measure of random vibration; the root mean square of acceleration levels in a random vibration test profile

## H

**hr** Hours

**Hz** Hertz—Cycles per second

## I

**IEC** International Electrotechnical Commission—An organization that sets international electrical and electronics standards

**IEEE** Institute of Electrical and Electronics Engineers

**$I_{\text{MP}}$**  Mainframe peak current



in. Inches

inhibit To turn off

## **J**

jitter A measure of the small, rapid variations in clock transition times from their nominal regular intervals. Units: seconds RMS.

## **K**

kg Kilograms

km Kilometers

## **L**

lb Pounds

load regulation The maximum steady-state percentage that a DC voltage output will change as a result of a step change from no-load to full-load output current

## **M**

m Meters

MAX NI Measurement & Automation Explorer, the utility that allows you to configure and test your PXI system

MHz Megahertz—One million Hertz; one Hertz equals one cycle per second

ms Millisecond—One thousandth of a second ( $10^{-3}$ )

## **N**

NEMA National Electrical Manufacturers Association

NI National Instruments

NI-DAQmx	National Instruments driver that controls the operation of National Instruments data acquisition (DAQ) devices
NI-VISA	National Instruments implementation of the VISA (Virtual Instrument System Architecture) I/O standard. NI-VISA provides support for the VISA API, and also provides VISAIC, a utility for instrument configuration and I/O function execution.
ns	Nanosecond—One billionth of a second ( $10^{-9}$ )
<b>P</b>	
ppm	Parts-per-million
PXI	PCI eXtensions for Instrumentation. PXI is an implementation of CompactPCI with added electrical features that meet the high performance requirements of instrumentation applications by providing triggering, local buses, and system clock capabilities.
PXI_CLK10	10 MHz PXI system reference clock
<b>R</b>	
RMS	Root mean square
<b>S</b>	
s	Seconds
skew	Deviation in signal transmission times
slot blocker	An assembly installed into an empty slot to improve the airflow in adjacent slots
ST	Star trigger
standby	The backplane is unpowered (off), but the chassis is still connected to AC power mains

star trigger slot                      This slot is located at slot 2 and has a dedicated trigger line between each peripheral slot. Use this slot for a module with ST functionality that can provide individual triggers to all other peripherals.

system reference clock                A 10 MHz clock, also called PXI\_CLK10, that is distributed to all peripheral slots in the chassis. The system reference clock can be used for synchronization of multiple modules in a measurement or control system. The PXI backplane specification defines implementation guidelines for PXI\_CLK10.

## **T**

TTL                                        Transistor-transistor logic

## **U**

UL                                         Underwriter's Laboratories

## **V**

V    Volts

VAC                                        Volts alternating current, or  $V_{\text{rms}}$

$V_{\text{pp}}$                                         Peak-to-peak voltage

## **W**

W    Watts

# Index

---

## Numerics

10 MHz system reference clock, A-7

## A

AC power cables (table), 1-2

## B

backplane

interoperability with CompactPCI, 1-6

local bus, 1-7

overview, 1-6

peripheral slots, 1-7

specifications, A-6

star trigger (ST) slot, 1-6

system reference clock, 1-8

trigger bus, 1-8

## C

cable options (table), 2-12

cables, power (table), 1-2

calibration certificate (NI resources), C-2

CE compliance specifications, A-5

chassis initialization file, 2-16

chassis number label (figure), 2-15

checking LEDs for status, 2-11

CompactPCI

installing modules (figure), 2-13

interoperability with NI PXI-1033

backplane, 1-6

configuration. *See* installation, configuration, and operation

connecting to the power supply, 2-4

conventions used in the manual, *viii*

cooling

air cooling of NI PXI-1033, 2-2

air intake (figure), 2-3

filler panel installation, 2-3

setting fan speed, 2-3

## D

Declaration of Conformity (NI resources), C-2

diagnostic tools (NI resources), C-1

dimensions (figure), A-8, A-9

documentation

conventions used in manual, *viii*

NI resources, C-1

related documentation, *ix*

drivers (NI resources), C-1

## E

electromagnetic compatibility

specifications, A-5

EMC filler panel kit, 1-5

environmental management specifications, A-6

examples (NI resources), C-1

## F

fan, setting speed, 2-3

filler panel installation, 2-3

## G

getting started, 2-4

ground, connecting, 2-4

## H

- handle/feet kit, 1-5
- help, technical support, C-1

## I

- installation
  - cabling, 2-9
  - hardware, 2-5
  - of an NI ExpressCard module, 2-5
  - of an NI PCI Express host card, 2-7
  - powering down the MXI-Express system, 2-10
  - powering up the MXI-Express system, 2-10
- installation, configuration, and operation
  - chassis initialization file, 2-16
  - configuration in MAX (figure), 2-14
  - connecting safety ground, 2-4
  - filler panel installation, 2-3
  - module installation, 2-12
    - CompactPCI or PXI modules (figure), 2-13
  - PXI configuration in MAX, 2-13
    - trigger configuration, 2-15
  - rack mounting, 2-4
  - setting fan speed, 2-3
  - site considerations, 2-2
  - testing power up, 2-4
  - unpacking, 1-1
- instrument drivers (NI resources), C-1
- interoperability with CompactPCI, 1-6

## K

- key features, 1-2
- KnowledgeBase, C-1

## L

- local bus
  - routing (figure), 1-7
  - star trigger and local bus routing (figure), 1-7

## M

- maintenance of NI PXI-1033, 3-1
  - cleaning
    - exterior cleaning, 3-2
    - fan filter, 3-2
    - interior cleaning, 3-2
  - preparation, 3-1
  - service interval, 3-1
  - static discharge damage (caution), 3-1
- MXI interface description, 1-6
- MXI-Express system getting started, 2-4
- MXI-Express, cable options (table), 2-12

## N

- National Instruments support and services, C-1
- NI ExpressCard module, 2-5
- NI PCI Express host card cable connection, 2-9
- NI PCI Express host card installation, 2-7
- NI PCI Express host card installation (figure), 2-8
- NI PXI-1033
  - backplane
    - interoperability with CompactPCI, 1-6
    - local bus, 1-7
    - overview, 1-6
    - peripheral slots, 1-7
    - star trigger (ST) slot, 1-6
    - system reference clock, 1-8
    - trigger bus, 1-8
  - bottom view of chassis, 1-5

- fan speed, setting, 2-3
- front view (figure), 1-3
- installation. *See* installation, configuration, and operation
- key features, 1-2
- maintenance. *See* maintenance of NI PXI-1033
- module cooling air intake (figure), 2-3
- optional equipment, 1-5
- rack mounting, 2-4
- rear view of chassis, 1-4
- safety ground, connecting, 2-4

## O

- online product certification, A-6
- optional equipment, 1-5
- overview, functional, 2-11

## P

- P1 (J1) connector
  - peripheral slot (table), B-4
  - star trigger slot (table), B-2
- P2 (J2) connector
  - peripheral slot (table), B-5
  - star trigger slot (table), B-3
- peripheral slots
  - overview, 1-7
  - P1 (J1) connector pinouts (table), B-4
  - P2 (J2) connector pinouts (table), B-5
- pinouts, B-1
  - P1 (J1) connector
    - peripheral slot (table), B-4
    - star trigger slot (table), B-2
  - P2 (J2) connector
    - peripheral slot (table), B-5
    - star trigger slot (table), B-3
- power cables (table), 1-2
- power switch, 2-4
- power up, testing, 2-4

- programming examples (NI resources), C-1
- PXI\_CLK10, 1-8
- PXI\_CLK10\_IN pin, 1-8

## R

- rack mount kit, 1-5
  - components (figure), A-10
- rack mounting, 2-4
- related documentation, *ix*

## S

- safety
  - and caution notices, 2-1
  - ground, connecting, 2-4
  - specifications, A-5
- service interval, 3-1
- setting fan speed, 2-3
- software
  - installation, 2-5
  - NI resources, C-1
- specifications, NI PXI-1033
  - 10 MHz system reference clock, A-7
  - acoustic emissions, A-4
    - sound power, A-4
    - sound pressure level (at operator position), A-4
  - backplane, A-6
  - CE compliance, A-5
  - chassis cooling, A-2
  - dimensions (figure), A-8, A-9
  - electrical
    - AC input, A-1
    - DC output, A-2
  - electromagnetic compatibility, A-5
  - environmental, A-3
  - environmental management, A-6
  - mechanical, A-7
  - online product certification, A-6
  - rack mount kit components (figure), A-10

- safety, A-5
- shock and vibration, A-4
- Waste Electrical and Electronic Equipment (WEEE), A-6

- star trigger (ST) slot
  - description, 1-6
  - P1 (J1) connector pinouts (table), B-2
  - P2 (J2) connector pinouts (table), B-3
  - star trigger and local bus routing (figure), 1-7
- star trigger and local bus routing (figure), 1-7
- support, technical, C-1
- system reference clock, 1-8

## T

- technical support, C-1
- testing power up, 2-4
- training and certification (NI resources), C-1
- trigger bus, 1-8
- troubleshooting (NI resources), C-1

## U

- unpacking the MXI-Express host card, 2-5
- unpacking, overview, 1-1

## W

- Waste Electrical and Electronic Equipment (WEEE) specifications, A-6
- Web resources, C-1