

COMPREHENSIVE SERVICES

We offer competitive repair and calibration services, as well as easily accessible documentation and free downloadable resources.

SELL YOUR SURPLUS

We buy new, used, decommissioned, and surplus parts from every NI series. We work out the best solution to suit your individual needs.

 Sell For Cash  Get Credit  Receive a Trade-In Deal

OBSOLETE NI HARDWARE IN STOCK & READY TO SHIP

We stock **New**, **New Surplus**, **Refurbished**, and **Reconditioned** NI Hardware.



Bridging the gap between the manufacturer and your legacy test system.

 1-800-915-6216

 www.apexwaves.com

 sales@apexwaves.com

All trademarks, brands, and brand names are the property of their respective owners.

Request a Quote

 **CLICK HERE**

PXIe-1078

PXI Express

NI PXIe-1078 User Manual

Worldwide Technical Support and Product Information

ni.com

Worldwide Offices

Visit ni.com/niglobal to access the branch office Web sites, which provide up-to-date contact information, support phone numbers, email addresses, and current events.

National Instruments Corporate Headquarters

11500 North Mopac Expressway Austin, Texas 78759-3504 USA Tel: 512 683 0100

For further support information, refer to the *Technical Support and Professional Services* appendix. To comment on National Instruments documentation, refer to the National Instruments Web site at ni.com/info and enter the Info Code feedback.

Important Information

Warranty

The NI PXIe-1078 is warranted against defects in materials and workmanship for a period of one year from the date of shipment, as evidenced by receipts or other documentation. National Instruments will, at its option, repair or replace equipment that proves to be defective during the warranty period. This warranty includes parts and labor.

The media on which you receive National Instruments software are warranted not to fail to execute programming instructions, due to defects in materials and workmanship, for a period of 90 days from date of shipment, as evidenced by receipts or other documentation. National Instruments will, at its option, repair or replace software media that do not execute programming instructions if National Instruments receives notice of such defects during the warranty period. National Instruments does not warrant that the operation of the software shall be uninterrupted or error free.

A Return Material Authorization (RMA) number must be obtained from the factory and clearly marked on the outside of the package before any equipment will be accepted for warranty work. National Instruments will pay the shipping costs of returning to the owner parts which are covered by warranty.

National Instruments believes that the information in this document is accurate. The document has been carefully reviewed for technical accuracy. In the event that technical or typographical errors exist, National Instruments reserves the right to make changes to subsequent editions of this document without prior notice to holders of this edition. The reader should consult National Instruments if errors are suspected. In no event shall National Instruments be liable for any damages arising out of or related to this document or the information contained in it.

EXCEPT AS SPECIFIED HEREIN, NATIONAL INSTRUMENTS MAKES NO WARRANTIES, EXPRESS OR IMPLIED, AND SPECIFICALLY DISCLAIMS ANY WARRANTY OF MERCHANTABILITY OR FITNESS FOR A PARTICULAR PURPOSE. CUSTOMER'S RIGHT TO RECOVER DAMAGES CAUSED BY FAULT OR NEGLIGENCE ON THE PART OF NATIONAL INSTRUMENTS SHALL BE LIMITED TO THE AMOUNT THEREFORE PAID BY THE CUSTOMER. NATIONAL INSTRUMENTS WILL NOT BE LIABLE FOR DAMAGES RESULTING FROM LOSS OF DATA, PROFITS, USE OF PRODUCTS, OR INCIDENTAL OR CONSEQUENTIAL DAMAGES, EVEN IF ADVISED OF THE POSSIBILITY THEREOF. This limitation of the liability of National Instruments will apply regardless of the form of action, whether in contract or tort, including negligence. Any action against National Instruments must be brought within one year after the cause of action accrues. National Instruments shall not be liable for any delay in performance due to causes beyond its reasonable control. The warranty provided herein does not cover damages, defects, malfunctions, or service failures caused by owner's failure to follow the National Instruments installation, operation, or maintenance instructions; owner's modification of the product; owner's abuse, misuse, or negligent acts; and power failure or surges, fire, flood, accident, actions of third parties, or other events outside reasonable control.

Copyright

Under the copyright laws, this publication may not be reproduced or transmitted in any form, electronic or mechanical, including photocopying, recording, storing in an information retrieval system, or translating, in whole or in part, without the prior written consent of National Instruments Corporation.

National Instruments respects the intellectual property of others, and we ask our users to do the same. NI software is protected by copyright and other intellectual property laws. Where NI software may be used to reproduce software or other materials belonging to others, you may use NI software only to reproduce materials that you may reproduce in accordance with the terms of any applicable license or other legal restriction.

End-User License Agreements and Third-Party Legal Notices

You can find end-user license agreements (EULAs) and third-party legal notices in the following locations:

- Notices are located in the <National Instruments>_Legal Information and <National Instruments> directories.
- EULAs are located in the <National Instruments>\Shared\MDF\Legal\license directory.
- Review <National Instruments>_Legal Information.txt for more information on including legal information in installers built with NI products.

Trademarks

LabVIEW, National Instruments, NI, ni.com, the National Instruments corporate logo, and the Eagle logo are trademarks of National Instruments Corporation. Refer to the *Trademark Information* at ni.com/trademarks for other National Instruments trademarks.

Other product and company names mentioned herein are trademarks or trade names of their respective companies.

Members of the National Instruments Alliance Partner Program are business entities independent from National Instruments and have no agency, partnership, or joint-venture relationship with National Instruments.

Patents

For patents covering National Instruments products/technology, refer to the appropriate location: **Help»Patents** in your software, the `patents.txt` file on your media, or the *National Instruments Patent Notice* at ni.com/patents.

Export Compliance Information

Refer to the *Export Compliance Information* at ni.com/legal/export-compliance for the National Instruments global trade compliance policy and how to obtain relevant HTS codes, ECCNs, and other import/export data.

WARNING REGARDING USE OF NATIONAL INSTRUMENTS PRODUCTS

(1) NATIONAL INSTRUMENTS PRODUCTS ARE NOT DESIGNED WITH COMPONENTS AND TESTING FOR A LEVEL OF RELIABILITY SUITABLE FOR USE IN OR IN CONNECTION WITH SURGICAL IMPLANTS OR AS CRITICAL COMPONENTS IN ANY LIFE SUPPORT SYSTEMS WHOSE FAILURE TO PERFORM CAN REASONABLY BE EXPECTED TO CAUSE SIGNIFICANT INJURY TO A HUMAN.

(2) IN ANY APPLICATION, INCLUDING THE ABOVE, RELIABILITY OF OPERATION OF THE SOFTWARE PRODUCTS CAN BE IMPAIRED BY ADVERSE FACTORS, INCLUDING BUT NOT LIMITED TO FLUCTUATIONS IN ELECTRICAL POWER SUPPLY, COMPUTER HARDWARE MALFUNCTIONS, COMPUTER OPERATING SYSTEM SOFTWARE FITNESS, FITNESS OF COMPILERS AND DEVELOPMENT SOFTWARE USED TO DEVELOP AN APPLICATION, INSTALLATION ERRORS, SOFTWARE AND HARDWARE COMPATIBILITY PROBLEMS, MALFUNCTIONS OR FAILURES OF ELECTRONIC MONITORING OR CONTROL DEVICES, TRANSIENT FAILURES OF ELECTRONIC SYSTEMS (HARDWARE AND/OR SOFTWARE), UNANTICIPATED USES OR MISUSES, OR ERRORS ON THE PART OF THE USER OR APPLICATIONS DESIGNER (ADVERSE FACTORS SUCH AS THESE ARE HEREAFTER COLLECTIVELY TERMED "SYSTEM FAILURES"). ANY APPLICATION WHERE A SYSTEM FAILURE WOULD CREATE A RISK OF HARM TO PROPERTY OR PERSONS (INCLUDING THE RISK OF BODILY INJURY AND DEATH) SHOULD NOT BE RELIANT SOLELY UPON ONE FORM OF ELECTRONIC SYSTEM DUE TO THE RISK OF SYSTEM FAILURE. TO AVOID DAMAGE, INJURY, OR DEATH,

THE USER OR APPLICATION DESIGNER MUST TAKE REASONABLY PRUDENT STEPS TO PROTECT AGAINST SYSTEM FAILURES, INCLUDING BUT NOT LIMITED TO BACK-UP OR SHUT DOWN MECHANISMS. BECAUSE EACH END-USER SYSTEM IS CUSTOMIZED AND DIFFERS FROM NATIONAL INSTRUMENTS' TESTING PLATFORMS AND BECAUSE A USER OR APPLICATION DESIGNER MAY USE NATIONAL INSTRUMENTS PRODUCTS IN COMBINATION WITH OTHER PRODUCTS IN A MANNER NOT EVALUATED OR CONTEMPLATED BY NATIONAL INSTRUMENTS, THE USER OR APPLICATION DESIGNER IS ULTIMATELY RESPONSIBLE FOR VERIFYING AND VALIDATING THE SUITABILITY OF NATIONAL INSTRUMENTS PRODUCTS WHENEVER NATIONAL INSTRUMENTS PRODUCTS ARE INCORPORATED IN A SYSTEM OR APPLICATION, INCLUDING, WITHOUT LIMITATION, THE APPROPRIATE DESIGN, PROCESS AND SAFETY LEVEL OF SUCH SYSTEM OR APPLICATION.

Electromagnetic Compatibility Guidelines

This product was tested and complies with the regulatory requirements and limits for electromagnetic compatibility (EMC) as stated in the product specifications. These requirements and limits are designed to provide reasonable protection against harmful interference when the product is operated in its intended operational electromagnetic environment. There is no guarantee that interference will not occur in a particular installation. To minimize the potential for the product to cause interference to radio and television reception or to experience unacceptable performance degradation, install and use this product in strict accordance with the instructions in the product documentation.

The following statements contain important information needed before installing and using this product:



Caution This product is intended for use in industrial locations. As a result, this product may cause interference if used in residential areas. Such use must be avoided unless the user takes special measures to reduce electromagnetic emissions to prevent interference to the reception of radio and television broadcasts.



Caution To ensure the specified EMC performance, operate this product only with shielded cables and accessories.



Caution Changes or modifications not expressly approved by National Instruments could void the user's authority to operate the hardware under the local regulatory rules.

Contents

About This Manual

Related Documentation.....	ix
----------------------------	----

Chapter 1

Getting Started

Unpacking.....	1-1
What You Need to Get Started.....	1-1
Key Features.....	1-2
Chassis Description.....	1-3
Optional Equipment.....	1-5
EMC Filler Panels.....	1-5
Rack Mount Kit.....	1-5
Slot Blockers.....	1-6
Handle/Feet Kit.....	1-6
NI PXIe-1078 Chassis Backplane Overview.....	1-6
Interoperability with CompactPCI.....	1-6
System Controller Slot.....	1-7
Hybrid Peripheral Slots.....	1-8
PXI Express Peripheral Slots.....	1-8
PXI Local Bus.....	1-8
PXI Trigger Bus.....	1-9
System Reference Clock.....	1-9

Chapter 2

Installation and Configuration

Safety Information.....	2-1
Chassis Cooling Considerations.....	2-2
Providing Adequate Clearance.....	2-2
Chassis Ambient Temperature Definition.....	2-6
Setting Fan Speed.....	2-6
Installing Filler Panels.....	2-6
Installing Slot Blockers.....	2-6
Rack Mounting.....	2-6
Connecting Safety Ground.....	2-7
Connecting to Power Source.....	2-7
Installing a PXI Express System Controller.....	2-7
Installing Peripheral Modules.....	2-10
Power Inhibit Switch LED Indicator.....	2-11

Inhibit Mode Switch	2-12
PXI Express System Configuration with MAX	2-13
PXI-1 System Configuration.....	2-14
Using System Configuration and Initialization Files	2-15

Chapter 3

Maintenance

Service Interval.....	3-1
Preparation.....	3-1
Cleaning.....	3-2
Interior Cleaning	3-2
Exterior Cleaning	3-2

Appendix A

Specifications

Appendix B

Pinouts

Appendix C

Technical Support and Professional Services

Glossary

Index

About This Manual

The *NI PXIe-1078 User Manual* describes the features of the NI PXIe-1078 chassis and contains information about configuring the chassis, installing the modules, and operating the chassis.

Related Documentation

The following documents contain information that you might find helpful as you read this manual:

- IEEE 1101.1-1991, *IEEE Standard for Mechanical Core Specifications for Microcomputers Using IEC 603-2 Connectors*
- IEEE 1101.10, *IEEE Standard for Additional Mechanical Specifications for Microcomputers Using IEEE 1101.1 Equipment Practice*
- *PICMG EXP.0 R1.0 CompactPCI Express Specification*, PCI Industrial Computers Manufacturers Group
- *PCI Express Base Specification*, Revision 2.0, PCI Special Interest Group
- *PXI-5 PXI Express Hardware Specification*, Revision 1.0, PXI Systems Alliance

Getting Started

This chapter describes the key features of the NI PXIe-1078 chassis and lists the kit contents and optional equipment you can order from National Instruments.

Unpacking

Carefully inspect the shipping container and the chassis for damage. Check for visible damage to the metal work. Check to make sure all handles, hardware, and switches are undamaged. Inspect the inner chassis for any possible damage, debris, or detached components. If damage appears to have been caused during shipment, file a claim with the carrier. Retain the packing material for possible inspection and/or reshipment.

What You Need to Get Started

The NI PXIe-1078 chassis kit contains the following items:

- NI PXIe-1078 chassis
- Filler panels
- AC power cable—refer to Table 1-1 for AC power cables
- NI PXIe-1078 User Manual*
- Software media with *PXI Platform Services 2.0* or higher
- Read Me First: Safety and Electromagnetic Compatibility*
- Chassis number labels

Table 1-1. AC Power Cables

Power Cable	Reference Standards
Standard 120 V (USA)	ANSI C73.11/NEMA 5-15-P/IEC83
Switzerland 220 V	SEV
Australia 240 V	AS C112
Universal Euro 230 V	CEE (7), II, IV, VII IEC83
North America 120 V	ANSI C73.20/NEMA 5-15-P/IEC83
United Kingdom 230 V	BS 1363/IEC83

If you are missing any of the items listed in Table 1-1, or if you have the incorrect AC power cable, contact National Instruments.

Key Features

The NI PXIe-1078 combines a 9-slot PXI Express backplane with a structural design optimized for maximum usability in a wide range of applications.

The key features of the NI PXIe-1078 chassis include the following:

- Accepts 3U PXI Express, Compact PCI Express, and hybrid slot-compatible PXI-1/CompactPCI modules
 - 3 PXI Express peripheral slots directly connected as x1 links to the system slot
 - 5 hybrid peripheral slots connected as x1 links to a PCI Express switch, which is connected to the system through a x4 link
 - 32-bit, 33 MHz PCI connected to each hybrid slot
- Accepts 4-slot wide PXI Express embedded controller
- Rugged, compact chassis with universal AC input
- Auto/high temperature-controlled fan speed based on air intake temperature to minimize audible noise
- Rack mountable
- Optional carrying handle for portability

Chassis Description

Figures 1-1 and 1-2 show the key features of the NI PXIe-1078 chassis front and back panels. Figure 1-1 shows the front view of the NI PXIe-1078. Figure 1-2 shows the rear view of the NI PXIe-1078.

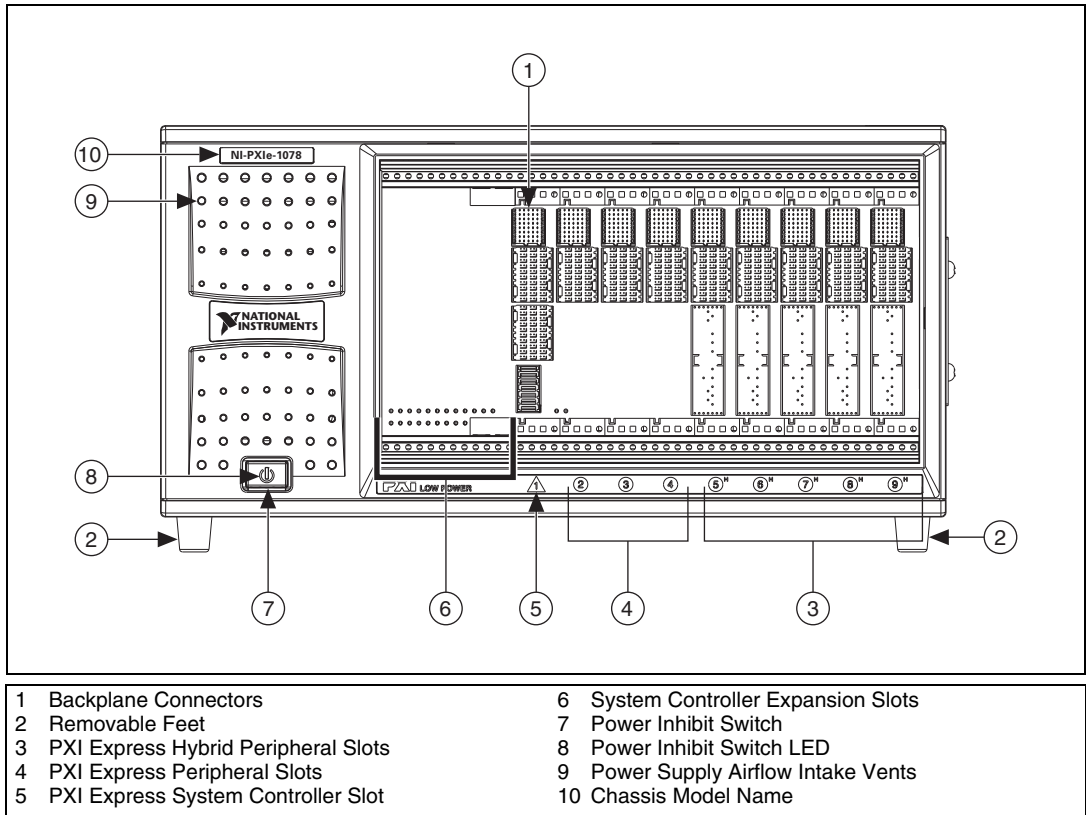

Figure 1-1. Front View of the NI PXIe-1078 Chassis

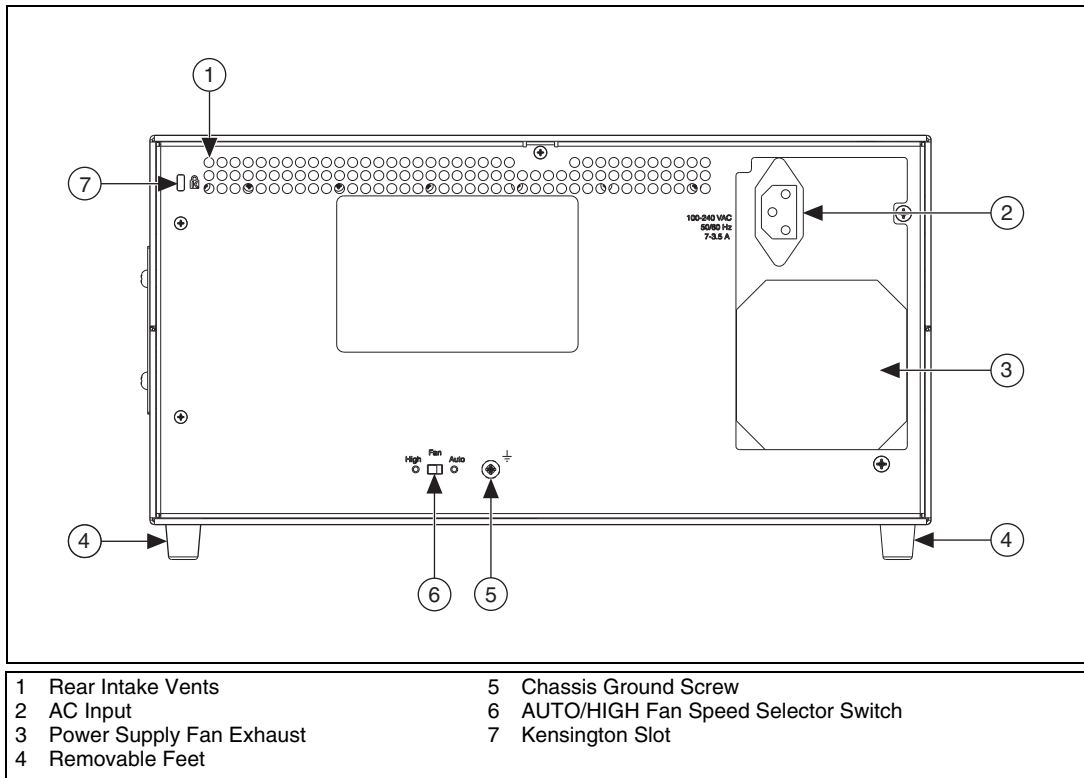

Figure 1-2. Rear View of the NI PXIe-1078 Chassis

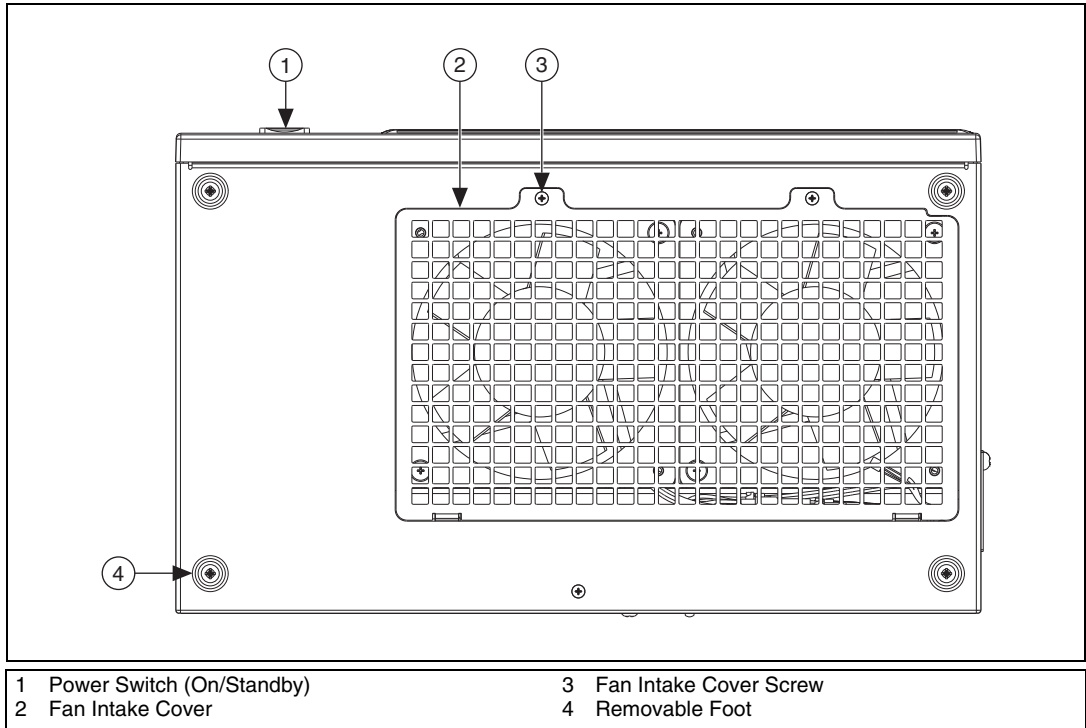

Figure 1-3. Bottom View of the NI PXIe-1078 Chassis

Optional Equipment

Contact National Instruments to order the following options for the NI PXIe-1078 chassis.

EMC Filler Panels

Optional EMC filler panel kits are available from National Instruments through part number 778700-01.

Rack Mount Kit

A rack mount kit option is available for mounting the NI PXIe-1078 chassis into a 19 in. instrument cabinet. Refer to Figure A-3, [NI Chassis Rack Mount Kit Components](#), for more information.

Slot Blockers

Optional slot blocker kits are available from National Instruments for improved thermal performance when all slots are not used.

Handle/Feet Kit

An optional side handle and rubber feet kit is available from National Instruments to provide a handle for portability.

NI PXIe-1078 Chassis Backplane Overview

This section provides an overview of the backplane features for the NI PXIe-1078 chassis.

Interoperability with CompactPCI

The design of the NI PXIe-1078 provides you the flexibility to use the following devices in a single PXI Express chassis:

- PXI Express compatible products
- CompactPCI Express compatible 4-Link system controller products
- CompactPCI Express compatible Type-2 peripheral products
- PXI peripheral products
- Standard CompactPCI peripheral products

Refer to Figure 1-4 for an overview of the NI PXIe-1078 architecture.

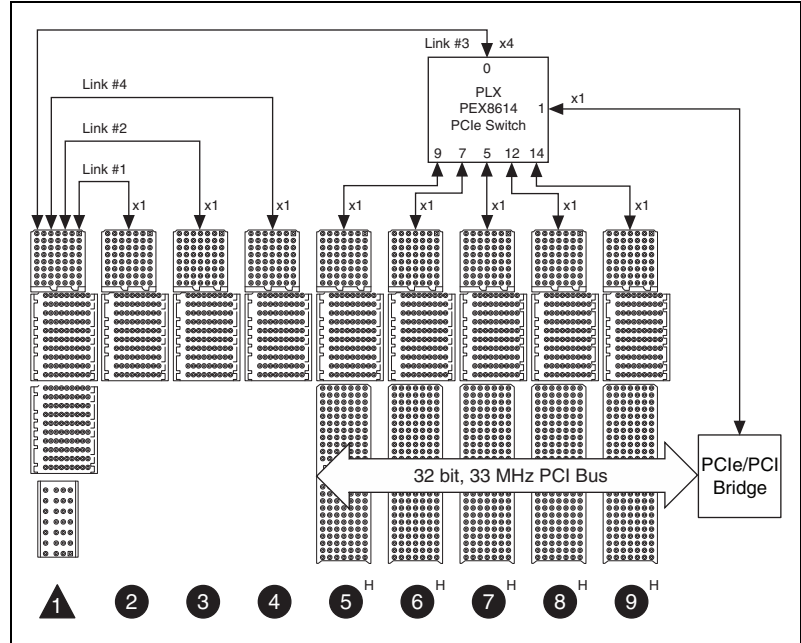

Figure 1-4. NI PXIe-1078 Backplane Architecture

System Controller Slot

The system controller slot is Slot 1 of the chassis and is a 4-Link configuration system slot as defined by the CompactPCI Express and PXI Express specifications. It has three system controller expansion slots for system controller modules that are wider than one slot. These slots allow the system controller to expand to the left to prevent the system controller from using peripheral slots.

The backplane routes three PCI Express (PCIe) links of the system slot to peripheral slots as x1 links. The other link of the system slot is routed as a x4 link to the upstream port of a PCI Express switch that in turn provides x1 PCIe links to the remaining peripheral slots. Refer to Figure 1-4 for PCI Express and PCI connectivity.

By default, the system controller will control the power supply with the PS_ON# signals. A logic low on this line will turn the power supply on.



Note The Inhibit Mode switch on the backplane must be in the **Default** position for the system controller to have control of the power supply. Refer to the *Inhibit Mode Switch* section of Chapter 2, *Installation and Configuration*, for details about the Inhibit Mode switch.

Hybrid Peripheral Slots

The chassis provides five hybrid peripheral slots as defined by the *PXI-5 PXI Express Hardware Specification*: slots 5-9. A hybrid peripheral slot can accept the following peripheral modules:

- A PXI Express Peripheral with a x1 PCI Express link through the PCIe switch to the system slot
- A CompactPCI Express Type-2 Peripheral with a x1 PCI Express link through the PCIe switch to the system slot
- A hybrid-compatible PXI Peripheral module that has been modified by replacing the J2 connector with an XJ4 connector installed in the upper eight rows of J2. Refer to the *PXI Express Specification* for details. The PXI Peripheral communicates through the backplane's 32-bit PCI bus.
- A CompactPCI 32-bit peripheral on the backplane's 32-bit PCI bus

The hybrid peripheral slots provide PXI Express functionality (excluding DSTAR and PXI Star) and 32-bit PXI functionality except for PXI Local Bus. The hybrid peripheral slot only connects to PXI Local Bus 6 left and right.

PXI Express Peripheral Slots

There are three PXI Express peripheral slots: slots 2-4. PXI Express peripheral slots can accept the following modules:

- A PXI Express peripheral with a x1 PCI Express link to the system slot
- A CompactPCI Express Type-2 peripheral with a x1 PCI Express link to the system slot

PXI Local Bus

The PXI backplane local bus is a daisy-chained bus that connects each peripheral slot with adjacent peripheral slots to the left and right.

The backplane routes PXI Local Bus 6 between adjacent PXI slots. The left Local Bus 6 from slot 1 is not routed anywhere. The right Local Bus 6 from slot 9 also is not routed anywhere.

Local bus signals may range from high-speed TTL signals to analog signals as high as 42 V.

Initialization software uses the configuration information specific to each adjacent peripheral module to evaluate local bus compatibility.

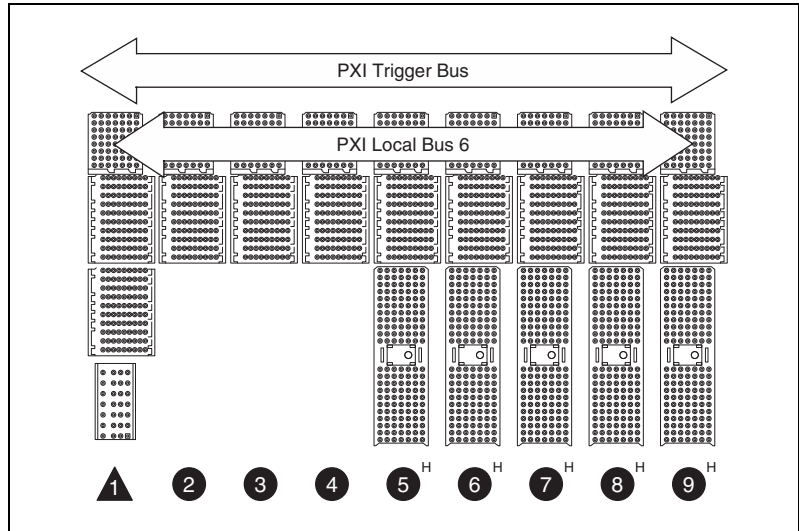

Figure 1-5. PXI Trigger Bus Connectivity Diagram

PXI Trigger Bus

All slots share eight trigger lines. You can use these trigger lines in a variety of ways. For example, you can use triggers to synchronize the operation of several different PXI peripheral modules. In other applications, one module can control carefully timed sequences of operations performed on other modules in the system. Modules can pass triggers to one another, allowing precisely timed responses to asynchronous external events the system is monitoring or controlling.

System Reference Clock

The NI PXIe-1078 chassis supplies PXI_CLK10, PXIe_CLK100, and PXIe_SYNC100 to every peripheral slot with an independent driver for each signal.

An independent buffer (having a source impedance matched to the backplane and a skew of less than 500 ps between slots) drives PXI_CLK10 to each peripheral slot. You can use this common reference clock signal to synchronize multiple modules in a measurement or control system.

An independent buffer drives PXIe_CLK100 to each peripheral slot. These clocks are matched in skew to less than 100 ps. The differential pair must be terminated on the peripheral with LVPECL termination for the buffer to drive PXIe_CLK100 so that when there is no peripheral or a peripheral that does not connect to PXIe_CLK100, there is no clock being driven on the pair to that slot.

An independent buffer drives PXIe_SYNC100 to each peripheral slot. The differential pair must be terminated on the peripheral with LVPECL termination for the buffer to drive PXIe_SYNC100 so that when there is no peripheral or a peripheral that does not connect to PXIe_SYNC100, there is no clock being driven on the pair to that slot.

PXI_CLK10, PXIe_CLK100 and PXIe_SYNC100 have the default timing relationship described in Figure 1-6.

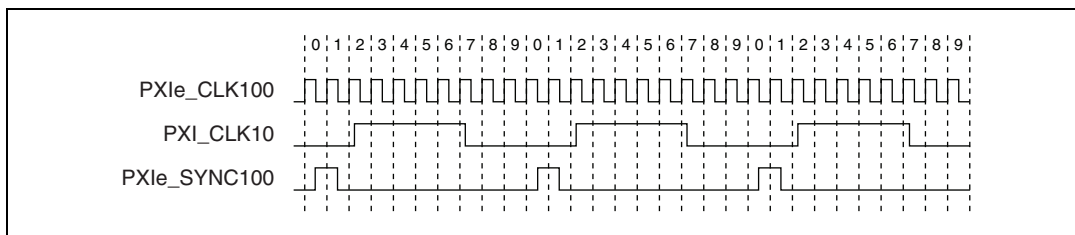

Figure 1-6. System Reference Clock Default Behavior

Installation and Configuration

This chapter describes how to prepare and operate the NI PXIe-1078 chassis.

Before connecting the chassis to a power source, read this chapter and the *Read Me First: Safety and Electromagnetic Compatibility* document included with your kit.

Safety Information



Caution Before undertaking any troubleshooting, maintenance, or exploratory procedure, carefully read the following caution notices.

This equipment contains voltage hazardous to human life and safety, and is capable of inflicting personal injury.

- **Chassis Grounding**—The chassis requires a connection from the premise wire safety ground to the chassis ground. The earth safety ground must be connected during use of this equipment to minimize shock hazards. Refer to the [Connecting Safety Ground](#) section for instructions on connecting safety ground.
- **Live Circuits**—Operating personnel and service personnel *must* not remove protective covers when operating or servicing the chassis. Adjustments and service to internal components must be undertaken by qualified service technicians. During service of this product, the mains connector to the premise wiring must be disconnected. Dangerous voltages may be present under certain conditions; use extreme caution.
- **Explosive Atmosphere**—Do *not* operate the chassis in conditions where flammable gases are present. Under such conditions, this equipment is unsafe and may ignite the gases or gas fumes.

- **Part Replacement**—Only service this equipment with parts that are exact replacements, both electrically and mechanically. Contact National Instruments for replacement part information. Installation of parts with those that are not direct replacements may cause harm to personnel operating the chassis. Furthermore, damage or fire may occur if replacement parts are unsuitable.
- **Modification**—Do *not* modify any part of the chassis from its original condition. Unsuitable modifications may result in safety hazards.

Chassis Cooling Considerations

The NI PXIe-1078 chassis is designed to operate on a bench or in an instrument rack. Regardless of the configuration, you must provide the cooling clearances as outlined in the following sections.

Providing Adequate Clearance



Caution Failure to provide adequate clearances may result in thermal related failures in the chassis or modules.

Apertures in the top, bottom, front, rear, and along the sides of the chassis facilitate power supply and module cooling, as shown in Figure 2-2. Air for module cooling enters through a fan intake in the bottom of the chassis. It then exits through the upper sections at the right side and top, as shown in Figure 2-1. Air for cooling the power supply enters the front and left side of the chassis and exits through the rear of the chassis, as shown in Figure 2-2.

Place the chassis on a bench top or in an instrument rack so that the fans (air intakes) and the air outlet apertures along the right side, the top, and the back of the chassis have adequate ventilation. Provide at least 44.5 mm (1.75 in.) clearance above, behind, and on the sides of the unit for adequate venting, as shown in Figure 2-3. High-power applications may require additional clearance.

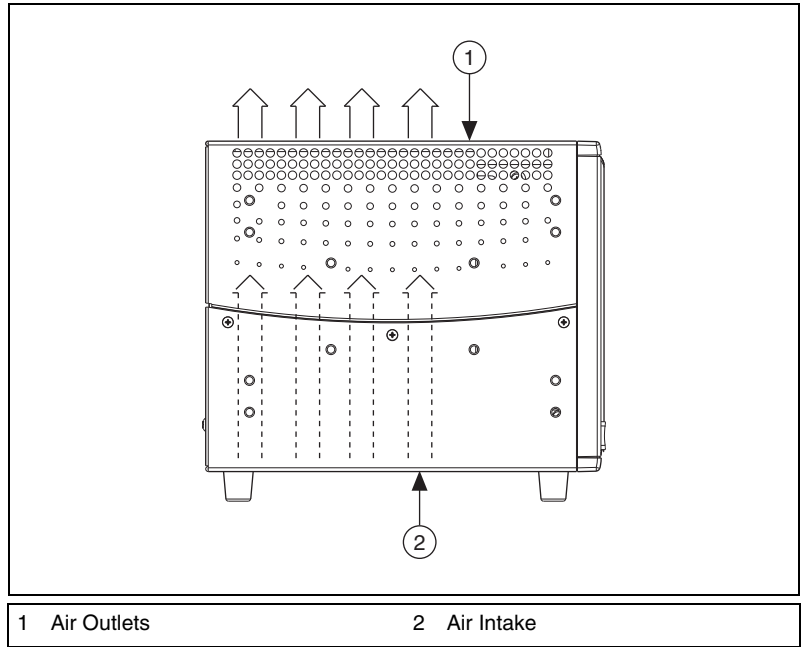

Figure 2-1. NI PXIe-1078 Module Cooling Airflow Side View

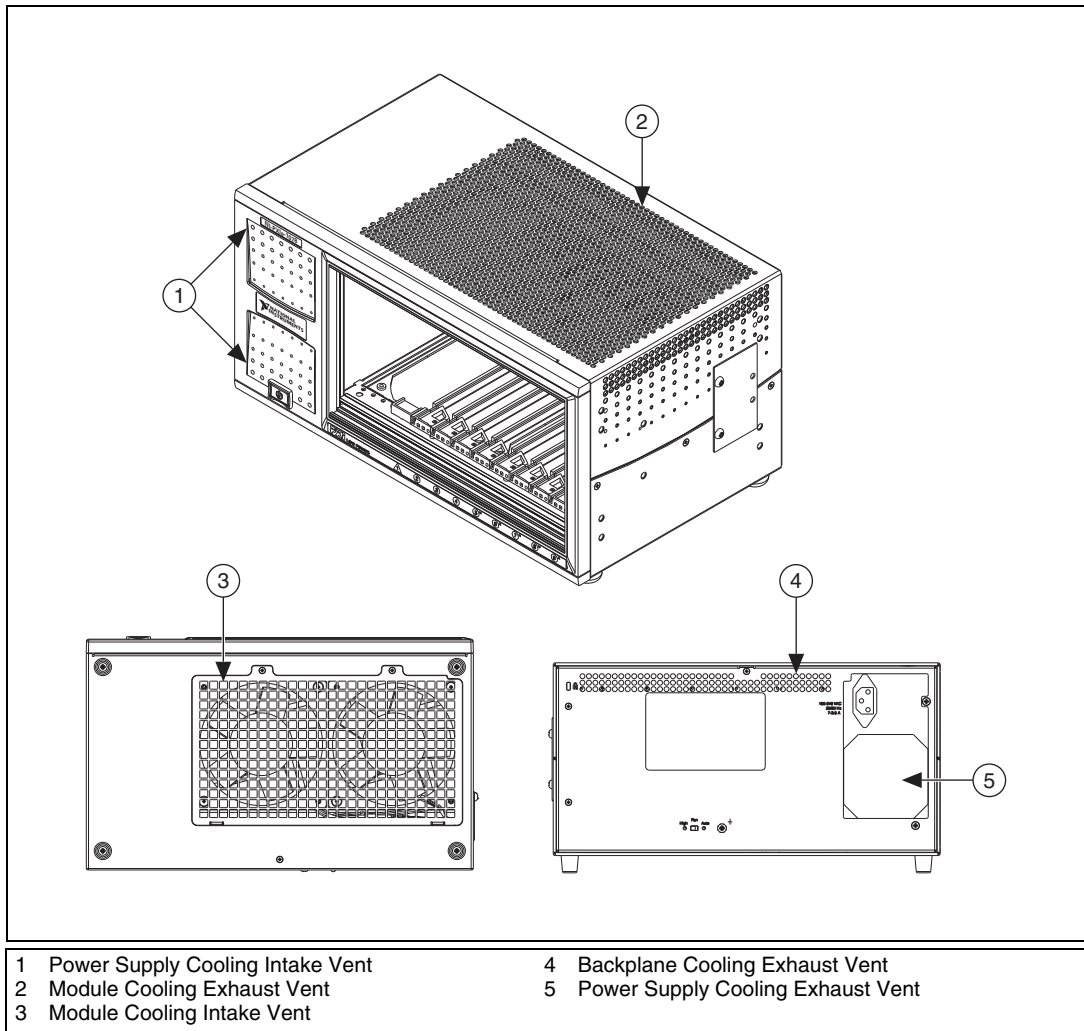

Figure 2-2. NI PXIe-1078 Vents

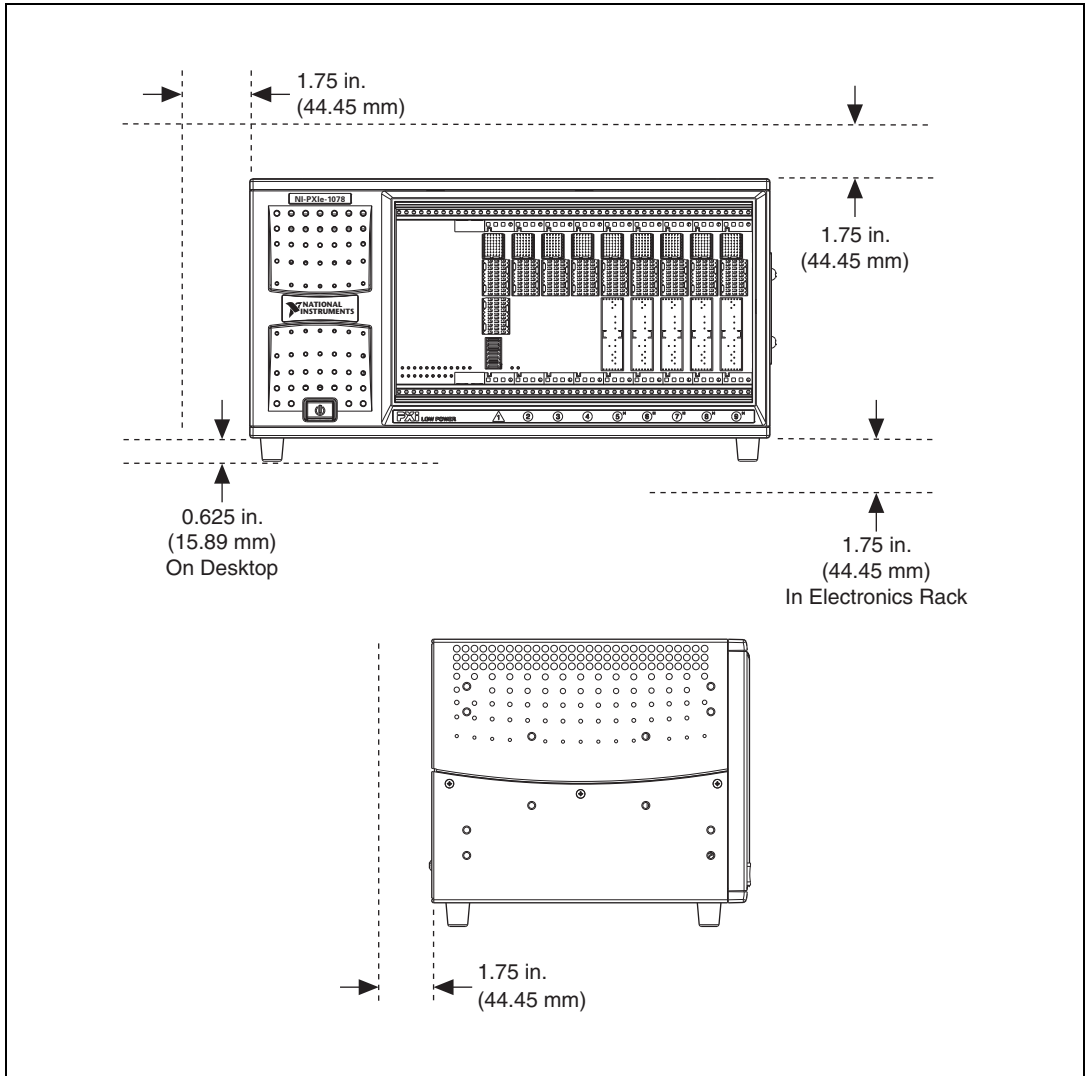

Figure 2-3. NI PXIe-1078 Cooling Clearances

Chassis Ambient Temperature Definition

The chassis fan control system uses intake air temperature as the input for controlling fan speeds when in Auto Fan Speed mode. Because of this, the chassis ambient temperature is defined as the temperature that exists just outside of the fan intake vent on the bottom of the chassis. Note that this temperature may be higher than ambient room temperature depending on the surrounding equipment and/or blockages present. You must ensure that this ambient temperature does not exceed the rated ambient temperature as stated in Appendix A, *Specifications*.

Setting Fan Speed

The AUTO/HIGH fan-speed selector switch is on the rear panel of the NI PXIe-1078. Refer to Figure 1-2, *Rear View of the NI PXIe-1078 Chassis*, to locate the fan-speed selector switch. Select HIGH for maximum cooling performance (recommended) or AUTO for quieter operation. When set to AUTO, the chassis intake air temperature determines the fan speed.

Installing Filler Panels

To maintain proper module cooling performance, install filler panels (provided with the chassis) in unused or empty slots. Secure with the captive mounting screws provided.

Installing Slot Blockers

You can improve the chassis cooling performance by installing optional slot blockers. Refer to ni.com for more details.

Rack Mounting

Rack mount applications require the optional rack mount kits available from National Instruments. Refer to the instructions supplied with the rack mount kits to install your NI PXIe-1078 chassis in an instrument rack. Refer to Figure A-3, *NI Chassis Rack Mount Kit Components*.



Note You may want to remove the feet from the NI PXIe-1078 chassis when rack mounting. To do so, remove the screws holding the feet in place.

Connecting Safety Ground



Caution The NI PXIe-1078 chassis is designed with a three-position inlet that connects the cord set ground line to the chassis ground. To minimize shock hazard, make sure the electrical power outlet you use to power the chassis has an appropriate earth safety ground.

Connecting to Power Source



Cautions Do *not* install modules prior to performing the following power-on test.

To completely remove power, you *must* disconnect the AC power cable.

Attach input power through the rear AC inlet using the appropriate AC power cable supplied. Refer to Figure 1-2, [Rear View of the NI PXIe-1078 Chassis](#), to locate the AC inlet.

Installing a PXI Express System Controller

This section contains general installation instructions for installing a PXI Express system controller in a NI PXIe-1078 chassis. Refer to your PXI Express system controller user manual for specific instructions and warnings. To install a system controller, complete the following steps:

1. Inspect the slot 1 pins on the chassis backplane for any bending or damage prior to installation.
2. Connect the AC power source to the PXI Express chassis before installing the system controller. The AC power cord grounds the chassis and protects it from electrical damage while you install the system controller.
3. Install the system controller into the system controller slot (slot 1, indicated by the red card guides) by first placing the system controller PCB into the front of the card guides (top and bottom). Slide the system controller to the rear of the chassis, making sure that the injector/ejector handle is pushed down as shown in Figure 2-4.

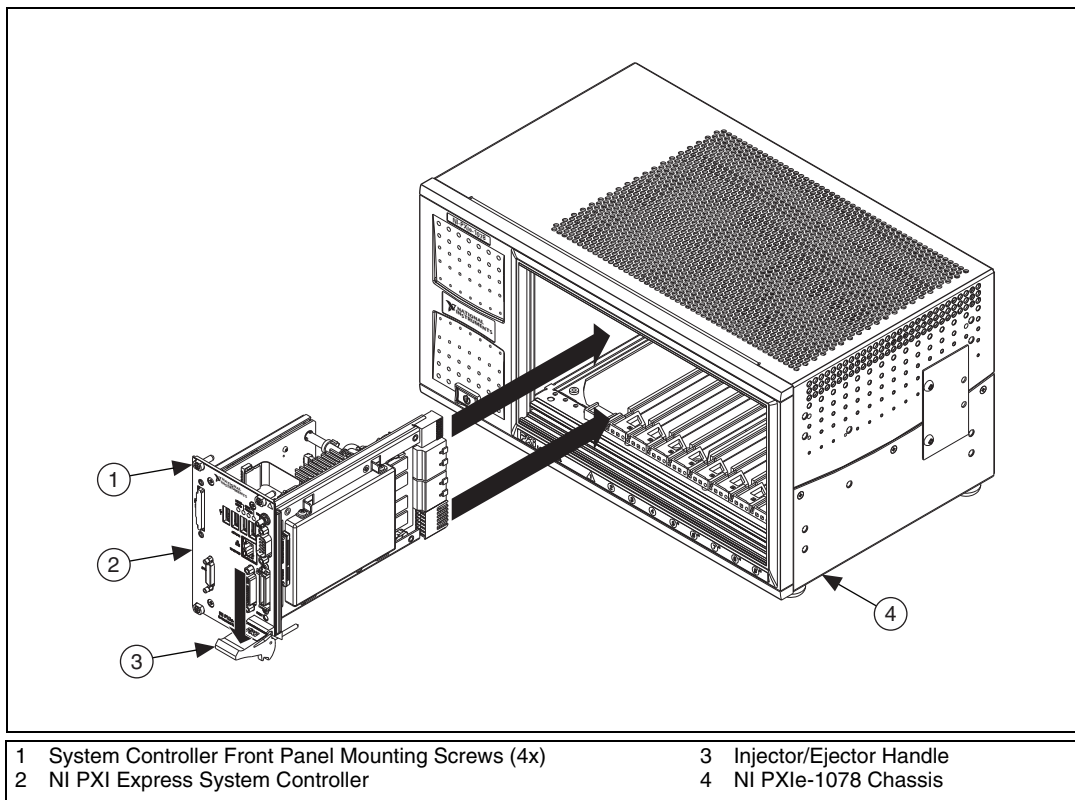

Figure 2-4. Installing a PXI Express System Controller

4. When you begin to feel resistance, push up on the injector/ejector handle to seat the system controller fully into the chassis frame. Secure the system controller front panel to the chassis using the system controller front-panel mounting screws.
5. Connect the keyboard, mouse, and monitor to the appropriate connectors. Connect devices to ports as required by your system configuration.
6. Power on the chassis. Verify that the system controller boots. If the system controller does not boot, refer to your system controller user manual.

Figure 2-5 shows a PXI Express system controller installed in the system controller slot of a NI PXIe-1078 chassis. You can place CompactPCI, CompactPCI Express, PXI, or PXI Express modules in other slots depending on the slot type.

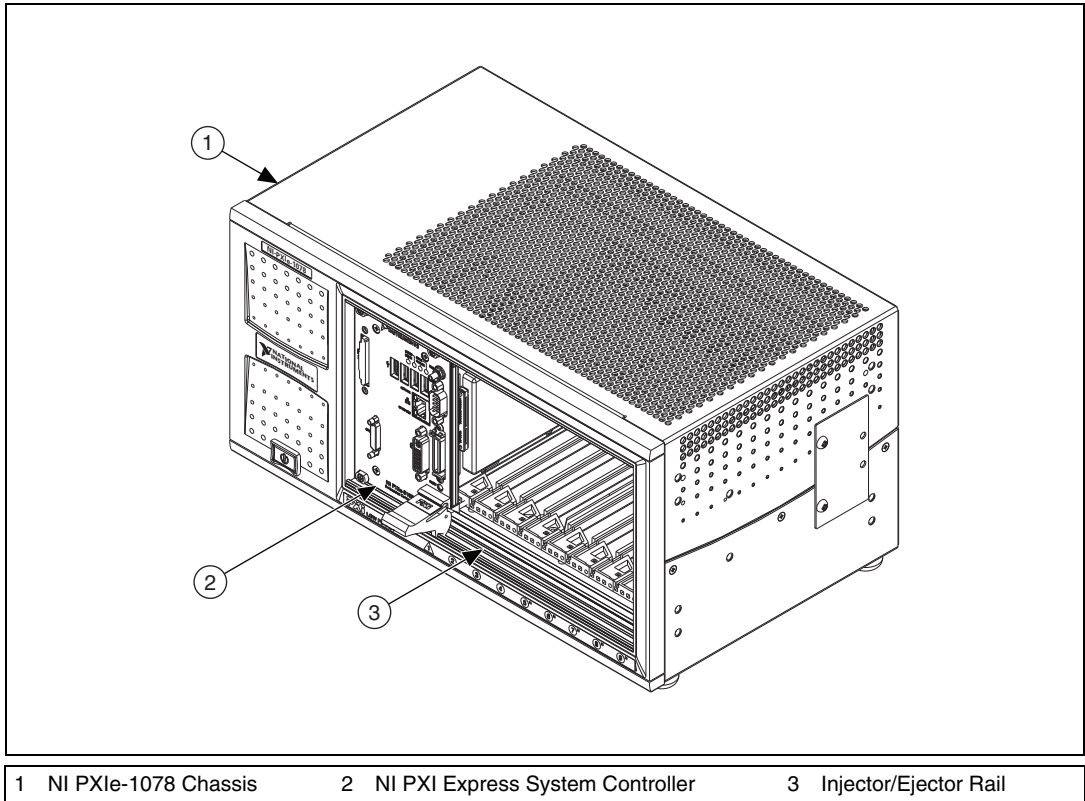

Figure 2-5. NI PXI Express System Controller Installed in an NI PXIe-1078 Chassis

Installing Peripheral Modules



Caution The NI PXIe-1078 chassis accepts a variety of peripheral module types in different slots. To prevent damage to the chassis, ensure that the peripheral module is being installed into a slot designed to accept it. Refer to Chapter 1, *Getting Started*, for a description of the various slot types.

This section contains general installation instructions for installing a peripheral module in a NI PXIe-1078 chassis. Refer to your peripheral module user manual for specific instructions and warnings. To install a module, complete the following steps:

1. Inspect the slot pins on the chassis backplane for any bending or damage prior to installation.
2. Connect the AC power source to the PXI Express chassis before installing the module. The AC power cord grounds the chassis and protects it from electrical damage while you install the module.
3. Ensure that the chassis is powered off.
4. Install a module into a chassis slot by first placing the module card PCB into the front of the card guides (top and bottom), as shown in Figure 2-6. Slide the module to the rear of the chassis, making sure that the injector/ejector handle is pushed down as shown in Figure 2-6.
5. When you begin to feel resistance, push up on the injector/ejector handle to fully seat the module into the chassis frame. Secure the module front panel to the chassis using the module front-panel mounting screws.

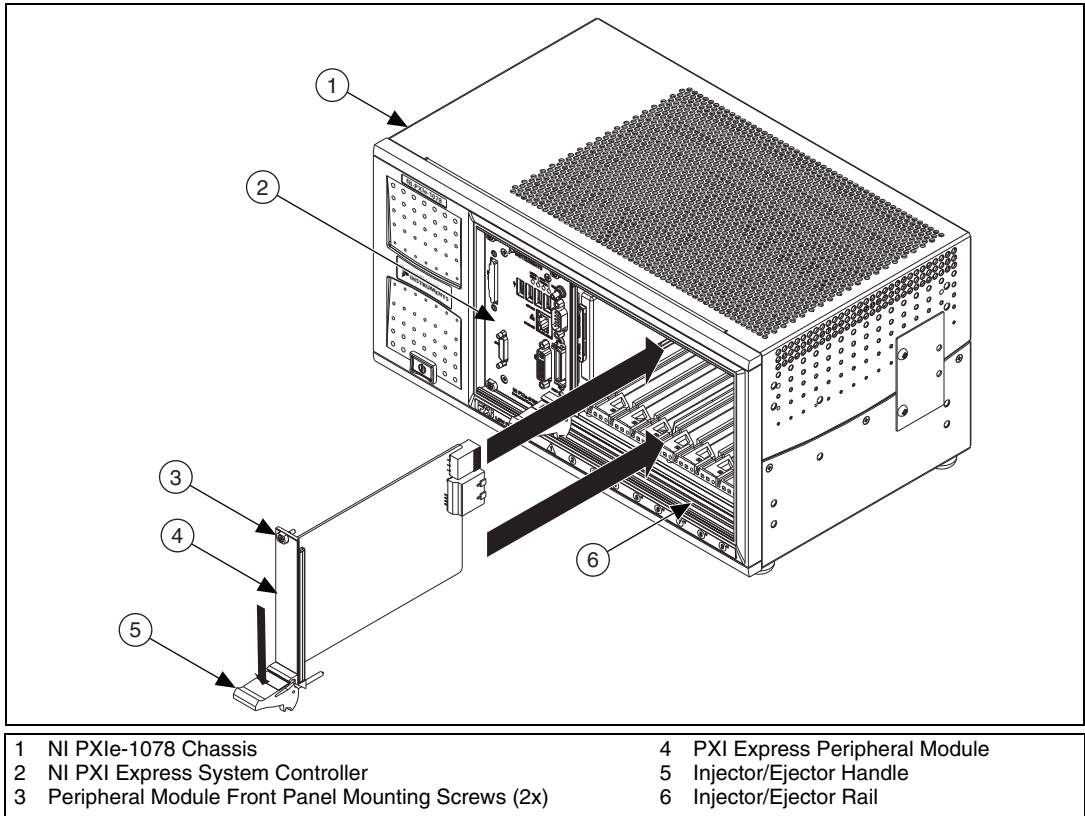

Figure 2-6. Installing PXI, PXI Express, or CompactPCI Peripheral Modules

Power Inhibit Switch LED Indicator

The chassis power inhibit switch has an integrated LED. This LED indicates one of two conditions:

- If the inhibit switch LED is steady green (not flashing), the chassis is powered on and operating normally.
- If the inhibit switch LED is red, the system fans have failed.

Inhibit Mode Switch

On the NI PXIe-1078 backplane is a four-position DIP switch (SW1). Switch 1 of SW1 controls the chassis inhibit mode. (Refer to Figure 2-7.) In its default position (OFF), the PXI Express controller controls the power supply on/off state based on the power switch on the chassis front panel.

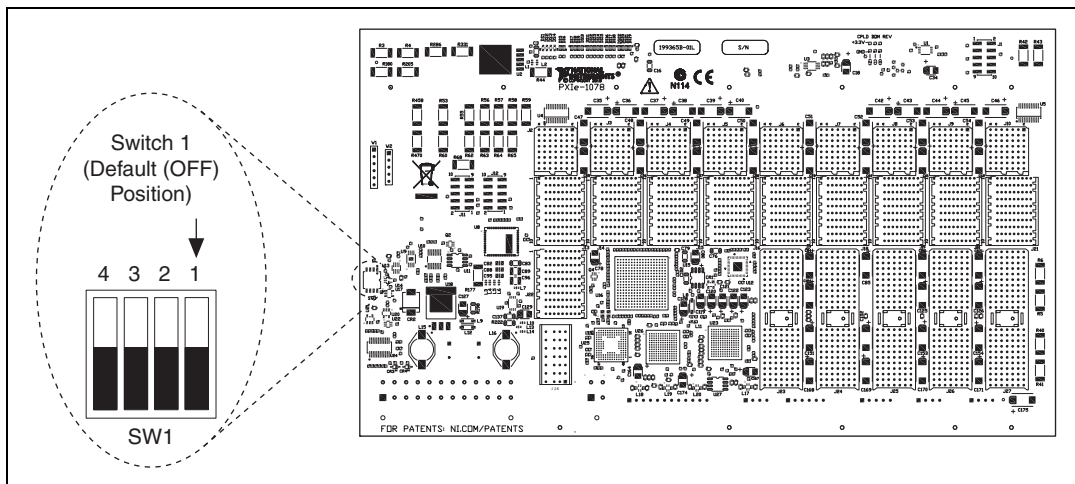

Figure 2-7. Switch 1 of SW1

When switch 1 of SW1 is on, the backplane controls the power supply on/off state. This allows you to circumvent the controller and turn the chassis on or off manually. When switch 1 of SW1 is on, the power supply turns on when you press the front panel power switch. When the power supply is on, holding down the front panel power switch for about one second turns the power supply off.



Cautions Be careful to avoid damaging the backplane when accessing this switch.

Suddenly removing power from an operating controller may result in loss of data and incorrect behavior on subsequent boots.

PXI Express System Configuration with MAX

The PXI Platform Services software included with your chassis automatically identifies your PXI Express system components to generate a `pxiesys.ini` file. You can configure your entire PXI system and identify PXI-1 chassis through Measurement & Automation Explorer (MAX), included with your system controller. MAX creates the `pxiesys.ini` and `pxisys.ini` file, which define your PXI system parameters. MAX also provides an interface to route and reserve triggers so dynamic routing, through drivers such as DAQmx, avoids double-driving and potentially damaging trigger lines. For more information about routing and reserving PXI triggers, refer to KnowledgeBase 3TJDOND8 at ni.com/support.

The configuration steps for single or multiple-chassis systems are the same.

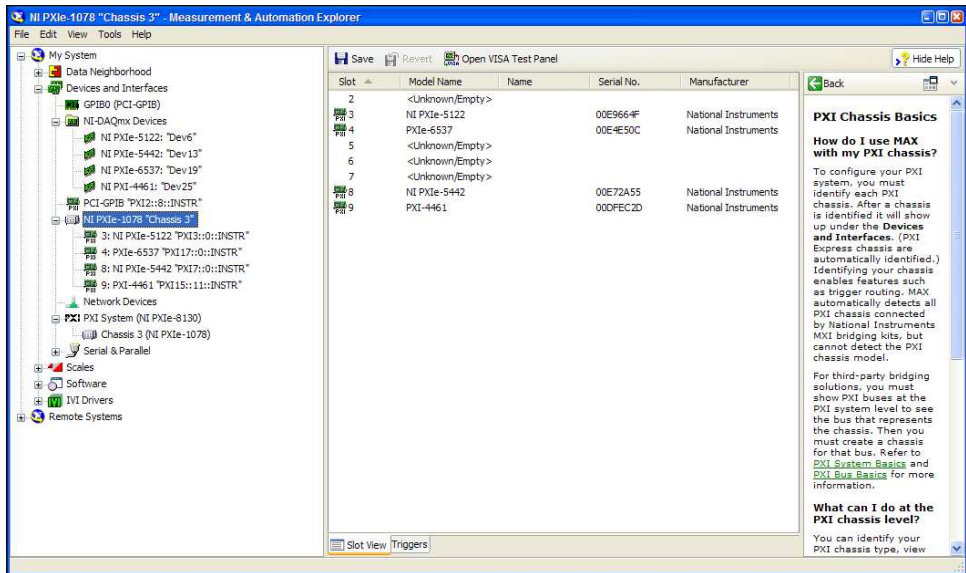

Figure 2-8. Multichassis Configuration in MAX

PXI-1 System Configuration

1. Launch MAX.
2. In the **Configuration** tree, click the **Devices and Interfaces** branch to expand it.
3. If the PXI system controller has not yet been configured, it is labeled **PXI System (Unidentified)**. Right-click this entry to display the pop-up menu, then select the appropriate system controller model from the **Identify As** submenu.
4. Click the PXI system controller. The chassis (or multiple chassis in a multichassis configuration) is listed below it. Identify each chassis by right-clicking its entry, then selecting the appropriate chassis model through the **Identify As** submenu. Further expanding the **PXI System** branch shows all devices in the system that can be recognized by NI-VISA. When your system controller and all your chassis are identified, the required `pxisys.ini` file is complete.

The PXI specification allows for many combinations of PXI chassis and system modules. To assist system integrators, the manufacturers of PXI chassis and system modules must document the capabilities of their products. PXI Express devices must provide a driver and `.ini` file for identification. These files are provided as part of the PXI Platform Services software included with your system controller. The minimum documentation requirements for PXI-1 are contained in `.ini` files, which consist of ASCII text. System integrators, configuration utilities, and device drivers can use these `.ini` files.

The capability documentation for a PXI-1 chassis is contained in a `chassis.ini` file provided by the chassis manufacturer. The information in this file is combined with information about the system controller to create a single PXI-1 system initialization file called `pxisys.ini` (PXI System Initialization). The NI system controller uses MAX to generate the `pxisys.ini` file from the `chassis.ini` file.

Device drivers and other utility software read the `pxiesys.ini` and `pxisys.ini` file to obtain system information. For detailed information about initialization files, refer to the PXI specification at www.pxisa.org.

Using System Configuration and Initialization Files

The PXI Express specification allows many combinations of PXI Express chassis and system modules. To assist system integrators, the manufacturers of PXI Express chassis and system modules must document the capabilities of their products. The minimum documentation requirements are contained in `.ini` files, which consist of ASCII text. System integrators, configuration utilities, and device drivers can use these `.ini` files.

The capability documentation for the NI PXIe-1078 chassis is contained in the `chassis.ini` file on the software media that comes with the chassis. The information in this file is combined with information about the system controller to create a single system initialization file called `pxisys.ini` (PXI System Initialization). The system controller manufacturer either provides a `pxisys.ini` file for the particular chassis model that contains the system controller or provides a utility that can read an arbitrary `chassis.ini` file and generate the corresponding `pxisys.ini` file. System controllers from NI provide the `pxisys.ini` file for the NI PXIe-1078 chassis, so you should not need to use the `chassis.ini` file. Refer to the documentation provided with the system controller or to ni.com/support for more information on `pxisys.ini` and `chassis.ini` files.

Device drivers and other utility software read the `pxisys.ini` file to obtain system information. The device drivers should have no need to directly read the `chassis.ini` file. For detailed information regarding initialization files, refer to the PXI Express specification at www.pxisa.org.

Maintenance

This chapter describes basic maintenance procedures you can perform on the NI PXIe-1078 chassis.



Caution Disconnect the power cable prior to servicing a NI PXIe-1078 chassis.

Service Interval

Clean dust from the chassis exterior (and interior) as needed, based on the operating environment. Periodic cleaning increases reliability and cooling performance.

Preparation

The information in this section is designed for use by qualified service personnel. Read the *Read Me First: Safety and Electromagnetic Compatibility* document included with your kit before attempting any procedures in this chapter.



Caution Many components within the chassis are susceptible to static discharge damage. Service the chassis only in a static-free environment. Observe standard handling precautions for static-sensitive devices while servicing the chassis. Always wear a grounded wrist strap or equivalent while servicing the chassis.

Cleaning

Cleaning procedures consist of exterior and interior cleaning of the chassis. Refer to your module user documentation for information about cleaning the individual CompactPCI or PXI Express modules.



Caution Always disconnect the AC power cable before cleaning or servicing the chassis.

Interior Cleaning

Use a dry, low-velocity stream of air to clean the interior of the chassis.
Use a soft-bristle brush for cleaning around components.

Exterior Cleaning

Clean the exterior surfaces of the chassis with a dry lint-free cloth or a soft-bristle brush. If any dirt remains, wipe with a cloth moistened in a mild soap solution. Remove any soap residue by wiping with a cloth moistened with clear water. Do not use abrasive compounds on any part of the chassis.



Cautions Avoid getting moisture inside the chassis during exterior cleaning, especially through the top vents. Use just enough moisture to dampen the cloth.

Do *not* wash the front- or rear-panel connectors or switches. Cover these components while cleaning the chassis.

Do *not* use harsh chemical cleaning agents; they may damage the chassis. Avoid chemicals that contain benzene, toluene, xylene, acetone, or similar solvents.

Specifications

This appendix contains specifications for the NI PXIe-1078 chassis.



Caution Specifications are subject to change without notice.

Electrical

AC Input

Input voltage range..... 100 to 240 VAC

Operating voltage range¹..... 90 to 264 VAC

Input frequency 50/60 Hz

Operating frequency range¹ 47 to 63 Hz

Input current rating..... 7-3.5 A

Line regulation

3.3 V..... $<\pm 0.2\%$

5 V..... $<\pm 0.1\%$

± 12 V $<\pm 0.1\%$

Efficiency 70% typical

Power disconnect The AC power cable provides main power disconnect.

¹ The operating range is guaranteed by design.

DC Output

DC current capacity (I_{MP})

Voltage	Maximum Current
+3.3 V	28.5 A
+5 V	26.5 A
+12 V	22.0 A
-12 V	0.75 A
5 V _{AUX}	1.5 A



Notes Maximum total usable power is 300 W.

Total usable power derates linearly to 288 W from 40 °C to 50 °C operating ambient temperature range.

The maximum combined power available on +3.3 V and +5 V is 125 W.

The maximum combined power available on +3.3 V and +5 V derates linearly to 100 W from 40 °C to 50 °C operating ambient temperature range.

The maximum available current from +12 V derates linearly to 16.5 A from 40 °C to 50 °C operating ambient temperature range.

The -12 V regulation is $\pm 5\%$ for loads of 8 A or less on the +12 V rail.

Backplane slot current capacity

Slot	+5 V	V (I/O)	+3.3 V	+12 V	-12 V	5 V _{AUX}
System Controller Slot	15 A	—	15 A	30 A	—	1 A
Hybrid Peripheral Slot with PXI-1 Peripheral	6 A	5 A	6 A	1 A	1 A	—
Hybrid Peripheral Slot with PXI-5 Peripheral	—	—	6 A	4 A	—	1 A
PXI Express Peripheral Slot	—	—	3 A	3 A	—	1 A



Notes Total system slot current should not exceed 45 A.

PCI V(I/O) pins in hybrid peripheral slots are connected to +5 V.

The maximum power dissipated in the system slot should not exceed 140 W.

The maximum power dissipated in a peripheral slot should not exceed 38.25 W.

Chassis Cooling

Per slot cooling capacity 38.25 W

Module cooling system Forced air circulation
(positive pressurization) through
2 150 CFM fans with High/Auto
speed selector

Slot airflow direction Bottom of module to top of
module

Module cooling intake Bottom of chassis

Module cooling exhaust Right side, rear, and top of chassis

Power supply cooling system..... Forced air circulation through
integrated fan

Power supply cooling intake Front and left side of chassis

Power supply cooling exhaust..... Rear of chassis

Environmental

Maximum altitude.....2,000 m (800 mbar)
(at 25 °C ambient)

Measurement Category.....II

Pollution Degree2

For indoor use only.

Operating Environment

Ambient temperature range0 to 50 °C
(Tested in accordance with
IEC-60068-2-1 and
IEC-60068-2-2. Meets
MIL-PRF-28800F Class 3
low temperature limit and
MIL-PRF-28800F Class 2
high temperature limit.)

Relative humidity range.....20 to 90%, noncondensing
(Tested in accordance with
IEC-60068-2-56.)

Storage Environment

Ambient temperature range-40 to 71 °C
(Tested in accordance with
IEC-60068-2-1 and
IEC-60068-2-2. Meets
MIL-PRF-28800F Class 3 limits.)

Relative humidity range.....10 to 95%, noncondensing
(Tested in accordance with
IEC-60068-2-56.)

Shock and Vibration

Operational shock 30 g peak, half-sine, 11 ms pulse
(Tested in accordance with
IEC-60068-2-27. Meets
MIL-PRF-28800F Class 2 limits.)

Random Vibration

Operating 5 to 500 Hz, 0.3 g_{rms}
Nonoperating 5 to 500 Hz, 2.4 g_{rms}
(Tested in accordance with
IEC-60068-2-64. Nonoperating
test profile exceeds the
requirements of
MIL-PRF-28800F, Class 3.)

Acoustic Emissions

Sound Pressure Level (at Operator Position)

Tested in accordance with ISO 7779. Meets MIL-PRF-28800F requirements.

Auto fan (up to ~30 °C ambient) 49.9 dBA

High fan..... 65.4 dBA

Sound Power

Auto fan (up to ~30 °C ambient) 59.3 dBA

High fan..... 74.1 dBA



Note Specifications are subject to change without notice.

Safety

This product is designed to meet the requirements of the following standards of safety for information technology equipment:

- IEC 61010-1, EN 61010-1
- UL 61010-1, CSA 61010-1



Note For UL and other safety certifications, refer to the product label or the [Online Product Certification](#) section.

Electromagnetic Compatibility

This product meets the requirements of the following EMC standards for electrical equipment for measurement, control, and laboratory use:

- EN 61326 (IEC 61326): Class A emissions; Basic immunity
- EN 55011 (CISPR 11): Group 1, Class A emissions
- AS/NZS CISPR 11: Group 1, Class A emissions
- FCC 47 CFR Part 15B: Class A emissions
- ICES-001: Class A emissions



Note For the standards applied to assess the EMC of this product, refer to the *Online Product Certification* section.



Note For EMC compliance, operate this device with shielded cabling.

CE Compliance

This product meets the essential requirements of applicable European Directives as follows:

- 2006/95/EC; Low-Voltage Directive (safety)
- 2004/108/EC; Electromagnetic Compatibility Directive (EMC)

Online Product Certification

Refer to the product Declaration of Conformity (DoC) for additional regulatory compliance information. To obtain product certifications and the DoC for this product, visit ni.com/certification, search by model number or product line, and click the appropriate link in the Certification column.

Environmental Management

NI is committed to designing and manufacturing products in an environmentally responsible manner. NI recognizes that eliminating certain hazardous substances from our products is beneficial to the environment and to NI customers.

For additional environmental information, refer to the *Minimize Our Environmental Impact* web page at ni.com/environment. This page contains the environmental regulations and directives with which NI complies, as well as other environmental information not included in this document.

Waste Electrical and Electronic Equipment (WEEE)



EU Customers At the end of the product life cycle, all products *must* be sent to a WEEE recycling center. For more information about WEEE recycling centers, National Instruments WEEE initiatives, and compliance with WEEE Directive 2002/96/EC on Waste and Electronic Equipment, visit ni.com/environment/weee.

电子信息产品污染控制管理办法（中国 RoHS）



中国客户 National Instruments 符合中国电子信息产品中限制使用某些有害物质指令 (RoHS)。关于 National Instruments 中国 RoHS 合规性信息, 请登录 ni.com/environment/rohs_china。(For information about China RoHS compliance, go to ni.com/environment/rohs_china.)

Backplane

Size.....	3U-sized; one system slot (with three system expansion slots) and eight peripheral slots. Compliant with IEEE 1101.10 mechanical packaging. PXI Express Specification compliant. Accepts both PXI Express and CompactPCI (PICMG 2.0 R 3.0) 3U modules.
Backplane bare-board material	UL 94 V-0 Recognized
Backplane connectors	Conforms to IEC 917 and IEC 1076-4-101, and are UL 94 V-0 rated

System Synchronization Clocks (PXI_CLK10, PXIe_CLK100, PXIe_SYNC100)

10 MHz System Reference Clock: PXI_CLK10

Maximum slot-to-slot skew	500 ps
Accuracy	±25 ppm max (guaranteed over the operating temperature range)
Maximum jitter	5 ps RMS phase-jitter (10 Hz-1 MHz range)
Duty-factor	45%-55%
Unloaded signal swing	3.3 V ±0.3 V



Note For other specifications refer to the *PXI-1 Hardware Specification*.

100 MHz System Reference Clock: PXIe_CLK100 and PXIe_SYNC100

Maximum slot-to-slot skew	100 ps
Accuracy	±25 ppm max (guaranteed over the operating temperature range)
Maximum jitter	3 ps RMS phase-jitter (10 Hz-12 kHz range) 2 ps RMS phase-jitter (12 kHz-20 MHz range)
Duty-factor for PXIe_CLK100	45%-55%
Absolute differential voltage (When terminated with a 50 Ω load to 1.30 V or Thévenin equivalent)	400-1000 mV



Note For other specifications refer to the *PXI-5 PXI Express Hardware Specification*.

Mechanical

Overall dimensions

Standard chassis

Height	6.97 in. (177 mm)
Width	14.00 in. (355.6 mm)
Depth	8.43 in. (214.2 mm)



Note 0.625 in. (15.89 mm) is added to height when feet are installed.

Weight	7.55 kg (16.6 lb)
Chassis materials	Stainless Steel, Extruded Aluminum, Cold Rolled Steel, and PC-ABS
Finish	Conductive Clear Iridite on Aluminum, Clear Chromate Zinc Plating on Cold Rolled Steel, Polyurethane Enamel, and Polyester Urethane Powder Paint

Figures A-1 and A-2 show the NI PXIe-1078 chassis dimensions. The holes shown are for the installation of the optional rack mount kits. Notice that the front and rear chassis mounting holes (size M4) are symmetrical.

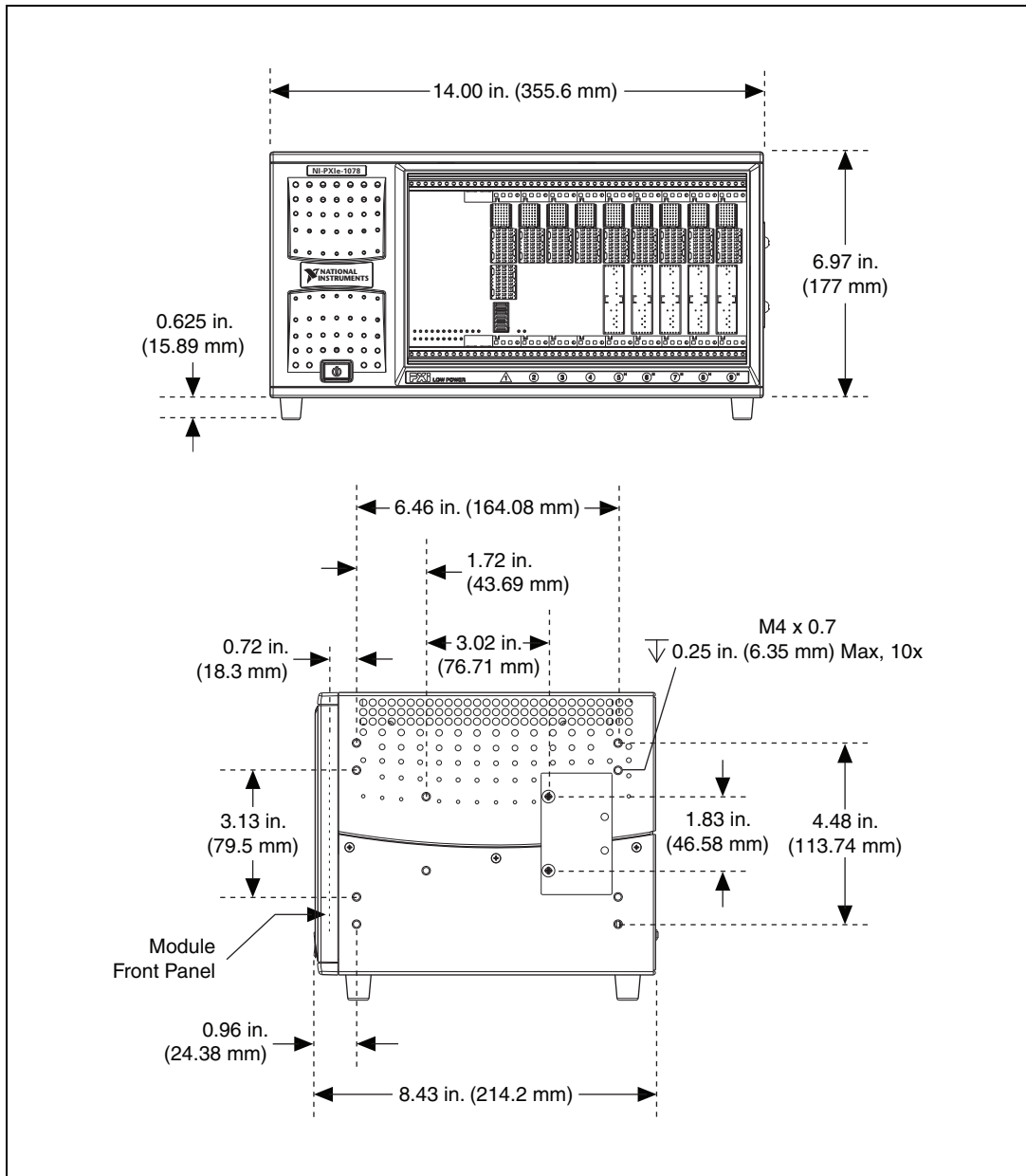

Figure A-1. NI PXIe-1078 Chassis Dimensions (Front and Side)

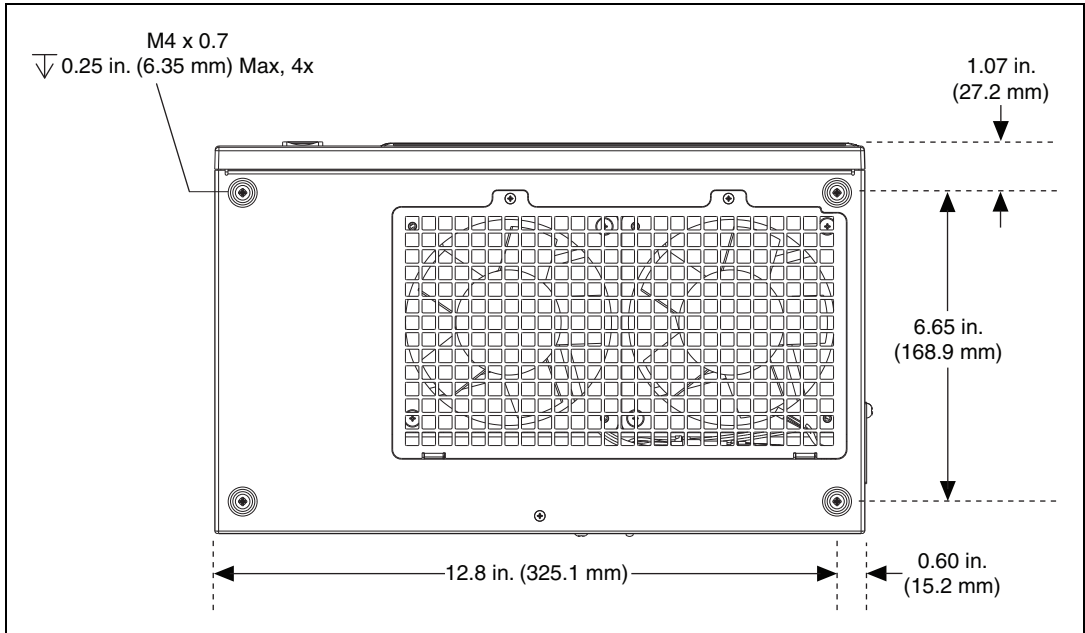

Figure A-2. NI PXIe-1078 Chassis Dimensions (Bottom)

Figure A-3 shows the chassis rack mount kit components.

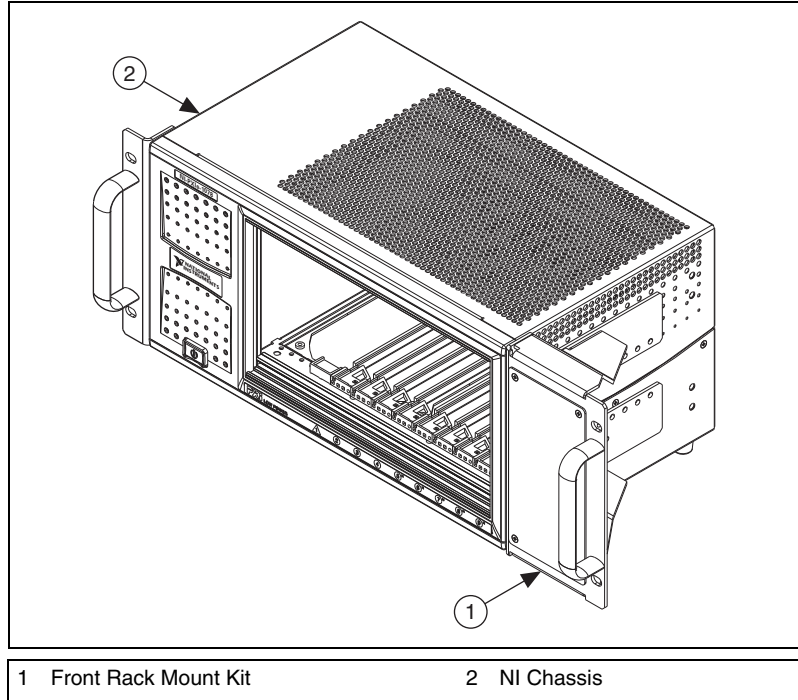

Figure A-3. NI Chassis Rack Mount Kit Components

Pinouts

This appendix describes the connector pinouts for the NI PXIe-1078 chassis backplane.

Table B-1 shows the XP1 connector pinout for the System Controller slot.

Table B-2 shows the XP2 Connector Pinout for the System Controller slot.

Table B-3 shows the XP3 Connector Pinout for the System Controller slot.

Table B-4 shows the XP4 Connector Pinout for the System Controller slot.

Table B-5 shows the P1 connector pinout for the Hybrid peripheral slots.

Table B-6 shows the XP3 Connector Pinout for the PXI Express and Hybrid peripheral slots.

Table B-7 shows the XP4 Connector Pinout for the PXI Express and Hybrid peripheral slots.

For more detailed information, refer to the *PXI-5 PXI Express Hardware Specification*, Revision 2.0. Contact the PXI Systems Alliance for a copy of the specification.

System Controller Slot Pinouts

Table B-1. XP1 Connector Pinout for the System Controller Slot

Pins	Signals
A	GND
B	3.3 V
C	5 V
D	GND
E	12 V
F	12 V
G	GND

Table B-2. XP2 Connector Pinout for the System Controller Slot

Pin	A	B	ab	C	D	cd	E	F	ef
1	3PETp1	3PETn1	GND	3PERp1	3PERn1	GND	3PETp2	3PETn2	GND
2	3PETp3	3PETn3	GND	3PERp3	3PERn3	GND	3PERp2	3PERn2	GND
3	4PETp0	4PETn0	GND	4PERp0	4PERn0	GND	4PETp1	4PETn1	GND
4	4PETp2	4PETn2	GND	4PERp2	4PERn2	GND	4PERp1	4PERn1	GND
5	4PETp3	4PETn3	GND	4PERp3	4PERn3	GND	RSV	RSV	GND
6	RSV	RSV	GND	RSV	RSV	GND	RSV	RSV	GND
7	RSV	RSV	GND	RSV	RSV	GND	RSV	RSV	GND
8	RSV	RSV	GND	RSV	RSV	GND	RSV	RSV	GND
9	RSV	RSV	GND	RSV	RSV	GND	RSV	RSV	GND
10	RSV	RSV	GND	RSV	RSV	GND	RSV	RSV	GND

Table B-3. XP3 Connector Pinout for the System Controller Slot

Pin	A	B	ab	C	D	cd	E	F	ef
1	RSV	RSV	GND	RSV	RSV	GND	RSV	RSV	GND
2	RSV	RSV	GND	PWR_OK	PS_ON#	GND	LINKCAP	PWRBTN#	GND
3	SMBDAT	SMBCLK	GND	4RefClk+	4RefClk-	GND	2RefClk+	2RefClk-	GND
4	RSV	PERST#	GND	3RefClk+	3RefClk-	GND	1RefClk+	1RefClk-	GND
5	1PETp0	1PETn0	GND	1PERp0	1PERn0	GND	1PETp1	1PETn1	GND
6	1PETp2	1PETn2	GND	1PERp2	1PERn2	GND	1PERp1	1PERn1	GND
7	1PETp3	1PETn3	GND	1PERp3	1PERn3	GND	2PETp0	2PETn0	GND
8	2PETp1	2PETn1	GND	2PERp1	2PERn1	GND	2PERp0	2PERn0	GND
9	2PETp2	2PETn2	GND	2PERp2	2PERn2	GND	2PETp3	2PETn3	GND
10	3PETp0	3PETn0	GND	3PERp0	3PERn0	GND	2PERp3	2PERn3	GND

Table B-4. XP4 Connector Pinout for the System Controller Slot

Pin	Z	A	B	C	D	E	F
1	GND	GA4	GA3	GA2	GA1	GA0	GND
2	GND	5Vaux	GND	SYSEN#	WAKE#	ALERT#	GND
3	GND	RSV	RSV	RSV	RSV	RSV	GND
4	GND	RSV	RSV	RSV	RSV	RSV	GND
5	GND	PXI_TRIG3	PXI_TRIG4	PXI_TRIG5	GND	PXI_TRIG6	GND
6	GND	PXI_TRIG2	GND	RSV	PXI_STAR	PXI_CLK10	GND
7	GND	PXI_TRIG1	PXI_TRIG0	RSV	GND	PXI_TRIG7	GND
8	GND	RSV	GND	RSV	RSV	PXI_LBR6	GND

Hybrid Slot Pinouts

Table B-5. P1 Connector Pinout for the Hybrid Slot

Pin	Z	A	B	C	D	E	F
25	GND	5 V	REQ64#	ENUM#	3.3 V	5 V	GND
24	GND	AD[1]	5V	V(I/O)	AD[0]	ACK64#	GND
23	GND	3.3 V	AD[4]	AD[3]	5 V	AD[2]	GND
22	GND	AD[7]	GND	3.3 V	AD[6]	AD[5]	GND
21	GND	3.3 V	AD[9]	AD[8]	M66EN	C/BE[0]#	GND
20	GND	AD[12]	GND	V(I/O)	AD[11]	AD[10]	GND
19	GND	3.3 V	AD[15]	AD[14]	GND	AD[13]	GND
18	GND	SERR#	GND	3.3 V	PAR	C/BE[1]#	GND
17	GND	3.3 V	IPMB_SCL	IPMB_SDA	GND	PERR#	GND
16	GND	DEVSEL#	GND	V(I/O)	STOP#	LOCK#	GND
15	GND	3.3 V	FRAME#	IRDY#	BD_SEL#	TRDY#	GND
12-14	Key Area						
11	GND	AD[18]	AD[17]	AD[16]	GND	C/BE[2]#	GND
10	GND	AD[21]	GND	3.3 V	AD[20]	AD[19]	GND
9	GND	C/BE[3]#	IDSEL	AD[23]	GND	AD[22]	GND
8	GND	AD[26]	GND	V(I/O)	AD[25]	AD[24]	GND
7	GND	AD[30]	AD[29]	AD[28]	GND	AD[27]	GND
6	GND	REQ#	GND	3.3 V	CLK	AD[31]	GND
5	GND	BRSVP1A5	BRSVP1B5	RST#	GND	GNT#	GND
4	GND	IPMB_PWR	HEALTHY#	V(I/O)	INTP	INTS	GND
3	GND	INTA#	INTB#	INTC#	5 V	INTD#	GND
2	GND	TCK	5 V	TMS	TDO	TDI	GND
1	GND	5 V	-12 V	TRST#	+12 V	5 V	GND

Table B-6. XP3 Connector Pinout for the PXI Express/Hybrid Slot

Pin	A	B	ab	C	D	cd	E	F	ef
1	PXIe_CLK100+	PXIe_CLK100-	GND	PXIe_SYNC100+	PXIe_SYNC100-	GND	PXIe_DSTARC+	PXIe_DSTARC-	GND
2	PRSNT#	PWREN#	GND	PXIe_DSTARB+	PXIe_DSTARB-	GND	PXIe_DSTARA+	PXIe_DSTARA-	GND
3	SMBDAT	SMBCLK	GND	RSV	RSV	GND	RSV	RSV	GND
4	MPWRGD*	PERST#	GND	RSV	RSV	GND	1RefClk+	1RefClk-	GND
5	1PETp0	1PETn0	GND	1PERp0	1PERn0	GND	1PETp1	1PETn1	GND
6	1PETp2	1PETn2	GND	1PERp2	1PERn2	GND	1PERp1	1PERn1	GND
7	1PETp3	1PETn3	GND	1PERp3	1PERn3	GND	1PETp4	1PETn4	GND
8	1PETp5	1PETn5	GND	1PERp5	1PERn5	GND	1PERp4	1PERn4	GND
9	1PETp6	1PETn6	GND	1PERp6	1PERn6	GND	1PETp7	1PETn7	GND
10	RSV	RSV	GND	RSV	RSV	GND	1PERp7	1PERn7	GND

Table B-7. XP4 Connector Pinout for the PXI Express/Hybrid Slot

Pin	Z	A	B	C	D	E	F
1	GND	GA4	GA3	GA2	GA1	GA0	GND
2	GND	5 Vaux	GND	SYSEN#	WAKE#	ALERT#	GND
3	GND	12 V	12 V	GND	GND	GND	GND
4	GND	GND	GND	3.3 V	3.3 V	3.3 V	GND
5	GND	PXI_TRIG3	PXI_TRIG4	PXI_TRIG5	GND	PXI_TRIG6	GND
6	GND	PXI_TRIG2	GND	ATNLED	PXI_STAR	PXI_CLK10	GND
7	GND	PXI_TRIG1	PXI_TRIG0	ATNSW#	GND	PXI_TRIG7	GND
8	GND	RSV	GND	RSV	PXI_LBL6	PXI_LBR6	GND



Technical Support and Professional Services

Log in to your National Instruments ni.com User Profile to get personalized access to your services. Visit the following sections of ni.com for technical support and professional services:

- **Support**—Technical support at ni.com/support includes the following resources:
 - **Self-Help Technical Resources**—For answers and solutions, visit ni.com/support for software drivers and updates, a searchable KnowledgeBase, product manuals, step-by-step troubleshooting wizards, thousands of example programs, tutorials, application notes, instrument drivers, and so on. Registered users also receive access to the NI Discussion Forums at ni.com/forums. NI Applications Engineers make sure every question submitted online receives an answer.
 - **Standard Service Program Membership**—This program entitles members to direct access to NI Applications Engineers via phone and email for one-to-one technical support, as well as exclusive access to self-paced online training modules at ni.com/self-paced-training. All customers automatically receive a one-year membership in the Standard Service Program (SSP) with the purchase of most software products and bundles including NI Developer Suite. NI also offers flexible extended contract options that guarantee your SSP benefits are available without interruption for as long as you need them. Visit ni.com/ssp for more information.

For information about other technical support options in your area, visit ni.com/services, or contact your local office at ni.com/contact.
- **Training and Certification**—Visit ni.com/training for training and certification program information. You can also register for instructor-led, hands-on courses at locations around the world.

- **System Integration**—If you have time constraints, limited in-house technical resources, or other project challenges, National Instruments Alliance Partner members can help. To learn more, call your local NI office or visit ni.com/alliance.
- **Declaration of Conformity (DoC)**—A DoC is our claim of compliance with the Council of the European Communities using the manufacturer’s declaration of conformity. This system affords the user protection for electromagnetic compatibility (EMC) and product safety. You can obtain the DoC for your product by visiting ni.com/certification.
- **Calibration Certificate**—If your product supports calibration, you can obtain the calibration certificate for your product at ni.com/calibration.

You also can visit the Worldwide Offices section of ni.com/niglobal to access the branch office Web sites, which provide up-to-date contact information, support phone numbers, email addresses, and current events.

Glossary

Symbol	Prefix	Value
p	pico	10^{-12}
n	nano	10^{-9}
μ	micro	10^{-6}
m	milli	10^{-3}
k	kilo	10^3
M	mega	10^6
G	giga	10^9
T	tera	10^{12}

Symbols

°	Degrees.
\geq	Equal or greater than.
\leq	Equal or less than.
%	Percent.

A

A	Amperes.
AC	Alternating current.
ANSI	American National Standards Institute.
Auto	Automatic fan speed control.
AWG	American Wire Gauge.

B

backplane An assembly, typically a printed circuit board, with connectors and signal paths that bus the connector pins.

BNC Bayonet Neill Concelman connector; a commonly used coaxial connector.

C

C Celsius.

CFM Cubic feet per minute.

CFR Code of Federal Regulations.

cm Centimeters.

CompactPCI An adaptation of the Peripheral Component Interconnect (PCI) Specification 2.1 or later for industrial and/or embedded applications requiring a more robust mechanical form factor than desktop PCI. It uses industry standard mechanical components and high-performance connector technologies to provide an optimized system intended for rugged applications. It is electrically compatible with the PCI Specification, which enables low-cost PCI components to be utilized in a mechanical form factor suited for rugged environments.

CSA Canadian Standards Association.

D

daisy-chain A method of propagating signals along a bus, in which the devices are prioritized on the basis of their position on the bus.

DB-9 A 9-pin D-SUB connector.

DC Direct current.

DoC Declaration of Conformity.

D-SUB Subminiature D connector.

E

efficiency	Ratio of output power to input power, expressed as a percentage.
EIA	Electronic Industries Association.
EMC	Electromagnetic Compatibility.
EMI	Electromagnetic Interference.

F

FCC	Federal Communications Commission.
filler panel	A blank module front panel used to fill empty slots in the chassis.

G

g	(1) grams; (2) a measure of acceleration equal to 9.8 m/s ² .
GPIB	General Purpose Interface Bus (IEEE 488).
g _{RMS}	A measure of random vibration. The root mean square of acceleration levels in a random vibration test profile.

H

hr	Hours.
Hz	Hertz; cycles per second.

I

IEC	International Electrotechnical Commission; an organization that sets international electrical and electronics standards.
IEEE	Institute of Electrical and Electronics Engineers.
I _{MP}	Mainframe peak current.

in. Inches.

inhibit To turn off.

J

jitter A measure of the small, rapid variations in clock transition times from their nominal regular intervals. Units: seconds RMS.

K

kg Kilograms.

km Kilometers.

L

lb Pounds.

LED Light emitting diode.

line regulation The maximum steady-state percentage that a DC voltage output will change as a result of a specified change in input AC voltage (step change from 90 to 132 VAC or 180 to 264 VAC).

load regulation The maximum steady-state percentage that a DC voltage output will change as a result of a step change from no-load to full-load output current.

M

m Meters.

MHz Megahertz. One million Hertz; one Hertz equals one cycle per second.

mi Miles.

ms Milliseconds.

MTBF Mean time between failure.

MTTR Mean time to repair.

N

NEMA National Electrical Manufacturers Association.

NI National Instruments.

P

power supply shuttle A removable module that contains the chassis power supply.

PXI PCI eXtensions for Instrumentation.

PXI_CLK10 10 MHz PXI system reference clock.

R

RH Relative humidity.

RMS Root mean square.

S

s Seconds.

skew Deviation in signal transmission times.

slot blocker An assembly installed into an empty slot to improve the airflow in adjacent slots.

standby The backplane is unpowered (off), but the chassis is still connected to AC power mains.

System controller A module configured for installation in Slot 1 of a PXI chassis. This device is unique in the PXI system in that it performs the system controller functions, including clock sourcing and arbitration for data transfers across the backplane. Installing such a device into any other slot can damage the device, the PXI backplane, or both.

system reference clock

A 10 MHz clock, also called PXI_CLK10, that is distributed to all peripheral slots in the chassis, as well as a BNC connector on the rear of chassis labeled *10 MHz REF OUT*. The system reference clock can be used for synchronization of multiple modules in a measurement or control system. The 10 MHz REF IN and OUT BNC connectors on the rear of the chassis can be used to synchronize multiple chassis to one reference clock. The PXI backplane specification defines implementation guidelines for PXI_CLK10.

System Timing slot

This slot is located at slot 4 and has dedicated trigger lines to other slots.

T

TTL

Transistor-transistor logic.

U

UL

Underwriter's Laboratories.

V

V

Volts.

VAC

Volts alternating current.

V_{pp}

Peak-to-peak voltage.

W

W

Watts.

Index

A

AC power cables (table), 1-2

B

backplane

- hybrid peripheral slots, 1-8
- interoperability with CompactPCI, 1-6
- overview, 1-6
- PXI Express peripheral slots, 1-8
- PXI local bus, routing, 1-8
- specifications, A-7
- system controller slot, 1-7
- system reference clock, 1-9
 - default behavior (figure), 1-10
- trigger bus, 1-9

C

- cables, power (table), 1-2
- calibration certificate (NI resources), C-2
- CE compliance specifications, A-6
- chassis ambient temperature definitions, 2-6
- chassis cooling considerations
 - ambient temperature definitions, 2-6
 - clearances, 2-2
 - figure, 2-5
 - vents (figure), 2-4
- chassis initialization file, 2-15
- chassis ventilation (figure), 2-4
- clearances for chassis cooling, 2-2
 - figure, 2-5
- CompactPCI
 - interoperability with NI PXIe-1078
 - backplane, 1-6
- configuration in MAX (figure), 2-13

configuration. *See* installation, configuration, and operation

cooling

- air cooling of NI PXIe-1078, 2-2
- air intake (figure), 2-3
- filler panel installation, 2-6
- setting fan speed, 2-6
- slot blocker installation, 2-6

D

- Declaration of Conformity (NI resources), C-2
- diagnostic tools (NI resources), C-1
- dimensions (figure), A-10, A-11
- documentation
 - NI resources, C-1
 - related documentation, *ix*
- drivers (NI resources), C-1

E

- electromagnetic compatibility, A-6
- EMC filler panel kit, 1-5
- environmental management specifications, A-6
 - WEEE information, A-7
- examples (NI resources), C-1

F

- fan, setting speed, 2-6
- filler panel installation, 2-6

G

- ground, connecting, 2-7

H

- handle/feet kit, 1-6
- help, technical support, C-1
- hybrid peripheral slots description, 1-8
- hybrid slot pinouts
 - P1 connector (table), B-4
 - XP3 connector (table), B-5
 - XP4 connector (table), B-5

I

- IEC 320 inlet, 1-4, 2-7
- inhibit mode switch, 2-12
- installation, configuration, and operation
 - chassis initialization file, 2-15
 - configuration in MAX (figure), 2-13
 - connecting safety ground, 2-7
 - filler panel installation, 2-6
 - installing a PXI Express system controller, 2-7
 - figure, 2-8
 - module installation
 - CompactPCI or PXI modules (figure), 2-11
 - peripheral module installation, 2-10
 - figure, 2-11
 - PXI Express configuration in MAX, 2-13
 - PXI Express system controller installed in a NI PXIe-1078 chassis (figure), 2-9
 - PXI-1 configuration in MAX, 2-14
 - rack mounting, 2-6
 - setting fan speed, 2-6
 - site considerations, 2-2
 - slot blocker installation, 2-6
 - testing power up, 2-7
 - unpacking the NI PXIe-1078, 1-1
- installing a PXI Express system controller (figure), 2-8
- instrument drivers (NI resources), C-1
- interoperability with CompactPCI, 1-6

K

- key features, 1-2
- kit contents, 1-1
- KnowledgeBase, C-1

M

- maintenance of NI PXIe-1078 chassis
 - cleaning
 - exterior cleaning, 3-2
 - interior cleaning, 3-2
 - preparation, 3-1
 - service interval, 3-1
 - static discharge damage (caution), 3-1

N

- National Instruments support and services, C-1
- NI PXIe-1078
 - fan speed, setting, 2-6
 - front view (figure), 1-3
 - installation. *See* installation, configuration, and operation
 - key features, 1-2
 - maintenance. *See* maintenance of NI PXIe-1078 chassis
 - module cooling air intake (figure), 2-3
 - optional equipment, 1-5
 - rack mounting, 2-6
 - rear view, 1-4
 - safety ground, connecting, 2-7
 - unpacking, 1-1
- NI PXIe-1078 backplane
 - hybrid peripheral slots, 1-8
 - interoperability with CompactPCI, 1-6
 - overview, 1-6
 - PXI Express peripheral slots, 1-8
 - PXI local bus, routing, 1-8
 - specifications, A-7
 - system controller slot, 1-7

- system reference clock, 1-9
 - default behavior (figure), 1-10
- trigger bus, 1-9

O

- optional equipment, 1-5

P

- peripheral module installation (figure), 2-11
- pinouts, B-1
- power cables (table), 1-2
- power inhibit switch LED indicator, 2-11
- power supply, connecting to, 2-7
- power up, testing, 2-7
- programming examples (NI resources), C-1
- PXI Express configuration in MAX, 2-13
- PXI Express peripheral slots description, 1-8
- PXI Express system controller, 2-7
 - figure, 2-8
 - installing in a NI PXIe-1078 chassis (figure), 2-9
- PXI local bus, routing, 1-8
- PXI trigger bus, routing (figure), 1-9
- PXI-1 configuration in MAX, 2-14

R

- rack mount kit dimensions (figure), A-12
- rack mounting, 2-6
 - kit, 1-5
- recycling hardware, A-7
- related documentation, *ix*

S

- safety and caution notices, 2-1
- safety ground, connecting, 2-7
- safety specifications, A-5
- service interval, 3-1

- setting fan speed, 2-6
- slot blocker
 - installation, 2-6
 - kit, 1-6
- software (NI resources), C-1
- specifications
 - acoustic emissions
 - sound power, A-5
 - sound pressure level (at operator position), A-5
 - backplane
 - 10 MHz system reference clock (PXI_CLK10), A-8
 - 100 MHz system reference clock (PXIe_CLK100 and PXIe_SYNC100), A-8
 - CE compliance, A-6
 - chassis cooling, A-3
 - dimensions (figure), A-10, A-11
 - electrical
 - AC input, A-1
 - DC output, A-2
 - electromagnetic compatibility, A-6
 - environmental
 - operating environment, A-4
 - storage environment, A-4
 - environmental management, A-6
 - WEEE information, A-7
 - mechanical, A-9
 - online product certification, A-6
 - rack mount kit dimensions (figure), A-12
 - safety, A-5
 - shock and vibration, A-5
 - system reference clocks, A-8
- static discharge damage (caution), 3-1
- support, technical, C-1
- system controller slot
 - description, 1-7
 - pinouts
 - XP1 connector (table), B-2
 - XP2 connector (table), B-2

- XP3 connector (table), B-3
- XP4 connector (table), B-3
- system reference clock, 1-9
 - default behavior (figure), 1-10
 - specifications, A-8

T

- technical support, C-1
- testing power up, 2-7
- training and certification (NI resources), C-1
- trigger bus, 1-9
- troubleshooting (NI resources), C-1

U

- unpacking the NI PXIe-1078 chassis, 1-1

W

- Web resources, C-1
- WEEE information, A-7