NI-9402 Getting Started

2024-10-11



Contents

NI-9402 Getting Started 3

NI-9402 Getting Started

NI-9402 Pinout

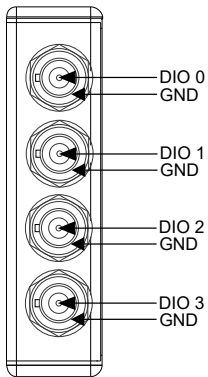

Table 1. Signal Descriptions

Signal	Description
DIO	Digital input/output signal connection
GND	Ground connection

Connecting Digital Devices to the NI-9402

You can connect digital devices to the NI-9402.

Figure 1. Connecting Digital Devices to the NI-9402

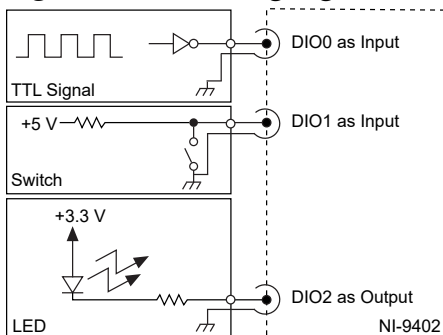

Each channel has a DIO pin to which you can connect a digital input or output device

through a 50 Ω BNC cable. You can configure each DIO channel of the NI-9402 in software for input or output. Changing the direction on any channel will not affect the direction on the other channels. Refer to the software help for information about configuring channel direction.

NI-9402 Block Diagram

Each channel on the NI-9402 can be configured in software for input or output. Changing the direction on any channel does not affect the direction on other channels.

Figure 2. NI-9402 Circuitry for One Channel

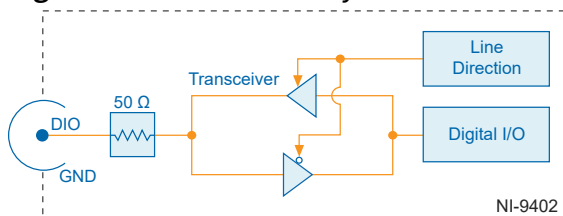

- Line direction logic enables/disables the line input and output transceiver. Setting the I/O line as input enables the input transceiver and disables the output receiver, and vice versa when the I/O line is set as output.
- The output impedance of the NI-9402 is 50 Ω , so the characteristic impedance of the BNC cable should be matched to 50 Ω to ensure optimal signal integrity.