

## COMPREHENSIVE SERVICES

We offer competitive repair and calibration services, as well as easily accessible documentation and free downloadable resources.

## SELL YOUR SURPLUS

We buy new, used, decommissioned, and surplus parts from every NI series. We work out the best solution to suit your individual needs.

 Sell For Cash    Get Credit    Receive a Trade-In Deal

## OBSOLETE NI HARDWARE IN STOCK & READY TO SHIP

We stock **New**, **New Surplus**, **Refurbished**, and **Reconditioned** NI Hardware.



*Bridging the gap between the manufacturer and your legacy test system.*

 1-800-915-6216

 [www.apexwaves.com](http://www.apexwaves.com)

 [sales@apexwaves.com](mailto:sales@apexwaves.com)

*All trademarks, brands, and brand names are the property of their respective owners.*

**Request a Quote**

 **CLICK HERE**

**PXIe-1082**

# INSTALLATION GUIDE

# 8-Slot NI PXIe-1082 Backplane

This guide describes installation requirements for the 8-slot NI PXIe-1082 backplane.

## Contents

---

NI PXIe-1082 Backplane Overview .....	2
Interoperability with CompactPCI.....	3
System Controller Slot.....	3
Hybrid Peripheral Slots.....	4
PXI Express Peripheral Slots.....	4
System Timing Slot .....	4
PXI Local Bus.....	6
PXI Trigger Bus.....	6
System Reference Clock.....	7
PXIe_SYNC_CTRL .....	9
Mechanical Requirements.....	10
Mounting.....	10
Dimensions .....	11
Cooling.....	11
Handling.....	12
Electrical Requirements .....	13
PXI Connectors.....	13
Power .....	14
Connector J37 .....	14
Connector J36.....	16
Connector J35.....	16
Connectors J2, J3, and J4.....	17
Backplane Specifications .....	17
System Synchronization Clock (PXI_CLK10, PXIe_CLK100, PXIe_SYNC100) Specifications.....	18
10 MHz System Reference Clock: PXI_CLK10.....	18
100 MHz System Reference Clock: PXIe_CLK100 and PXIe_SYNC100 .....	18
External Clock Source .....	19

PXIe_SYNC_CTRL.....	19
PXI Differential Star Triggers (PXIe-DSTARA, PXIe-DSTARB, PXIe-DSTARC).....	19
Pinouts .....	20
System Controller Slot Pinouts .....	21
System Timing Slot Pinouts .....	22
Hybrid Slot Pinouts .....	23

## NI PXIe-1082 Backplane Overview

This section provides an overview of the backplane features for the NI PXIe-1082 chassis. Figure 1 shows the backplane.

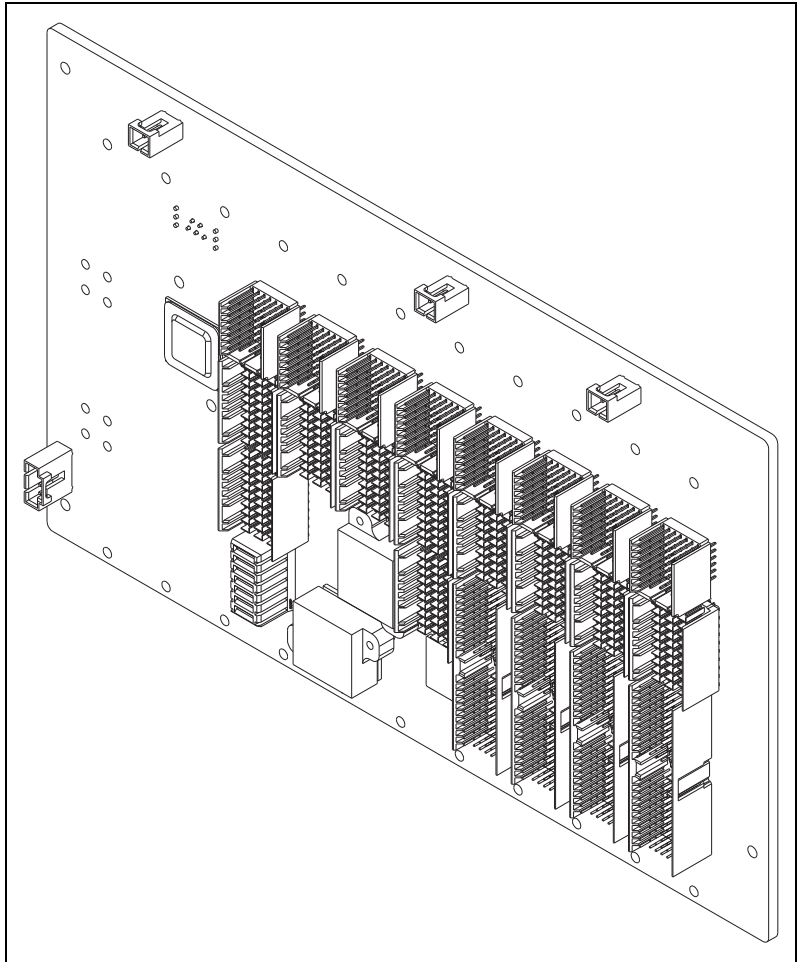

**Figure 1.** 8-Slot NI PXIe-1082 Backplane

# Interoperability with CompactPCI

With the NI PXIe-1082, you can use the following devices in a single PXI Express system:

- PXI Express-compatible products
- CompactPCI Express-compatible 4-Link system controller products
- CompactPCI Express-compatible Type-2 peripheral products
- Hybrid-compatible PXI peripheral products
- Standard CompactPCI peripheral products

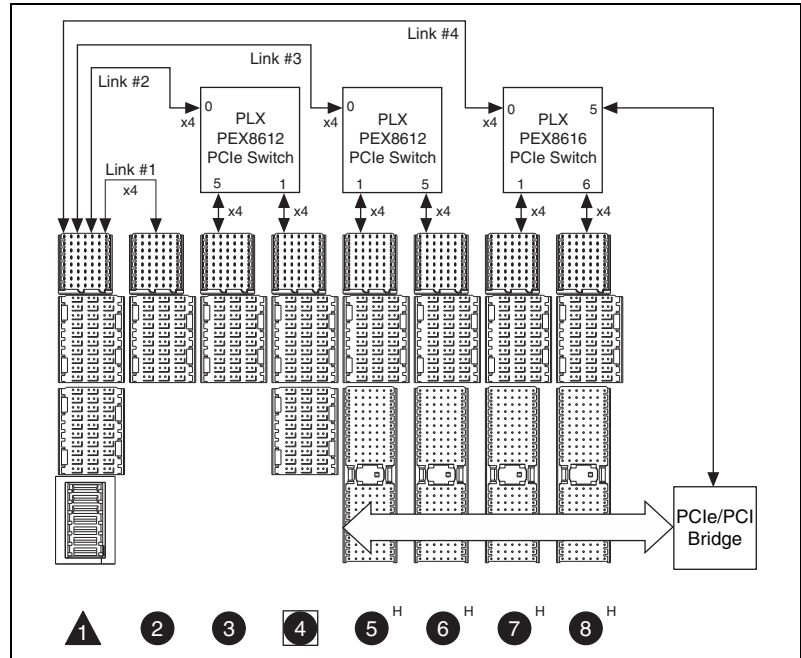

Figure 2. NI PXIe-1082 Backplane Architecture

## System Controller Slot

The system controller slot is Slot 1 of the chassis and is a 4-Link configuration system slot as defined by the CompactPCI Express and PXI Express specifications. It has three system controller expansion slots for system controller modules that are wider than one slot. These slots allow the system controller to expand to the left to prevent the system controller from using peripheral slots.

The backplane routes the first x4 PCI Express link from the system slot directly to slot 2. The other three x4 PCI Express links each are routed from the system slot to a PCI Express switch. The three PCI Express switches have x4 PCI Express links routed to each remaining peripheral

slot. One PCI Express switch also has a x1 PCI Express link routed to a PCI Express-to-PCI bridge that provides a 32-bit, 33 MHz PCI bus to the four hybrid slots. Refer to Figure 2 for the connectivity of PCI Express and PCI.

By default, the system controller controls the power supply with the PS\_ON# signals. A logic low on this line turns on the power supply.

## Hybrid Peripheral Slots

The backplane includes four hybrid peripheral slots as defined by the *PXI-5 PXI Express Hardware Specification*: slots 5 to 8. A hybrid peripheral slot can accept the following peripheral modules:

- A PXI Express peripheral with a x4 or x1 PCI Express link to the system slot or through a switch to the system slot.
- A CompactPCI Express Type-2 peripheral with a x4 or x1 PCI Express link to the system slot or through a switch to the system slot.
- A hybrid-compatible PXI peripheral module modified by replacing the J2 connector with an XJ4 connector installed in the upper eight rows of J2. Refer to the *PXI Express Specification* for details. The PXI peripheral communicates through the backplane 32-bit PCI bus.
- A CompactPCI 32-bit peripheral on the backplane 32-bit PCI bus.

The hybrid peripheral slots provide full PXI Express functionality and 32-bit PXI functionality except for PXI Local Bus. The hybrid peripheral slot connects only to PXI Local Bus 6 left and right.

## PXI Express Peripheral Slots

There are two PXI Express peripheral slots: slots 2 and 3. PXI Express peripheral slots can accept the following modules:

- A PXI Express peripheral with a x4 or x1 PCI Express link to the system slot or through a switch to the system slot.
- A CompactPCI Express Type-2 peripheral with a x4 or x1 PCI Express link to the system slot or through a switch to the system slot.

## System Timing Slot

The system timing slot is slot 4. The system timing slot accepts the following peripheral modules:

- A PXI Express system timing module with a x4 or x1 PCI Express link to the system slot through a PCI Express switch.
- A PXI Express peripheral with a x4 or x1 PCI Express link to the system slot through a PCI Express switch.
- A CompactPCI Express Type-2 peripheral with a x4 or x1 PCI Express link to the system slot through a PCI Express switch.

The system timing slot has three dedicated differential pairs (PXIe\_DSTAR) connected from the TP2 connector to the XP3 connector for each PXI Express peripheral or hybrid peripheral slot, as well as routed back to the XP3 connector of the system timing slot, as shown in Figure 3. You can use the PXIe\_DSTAR pairs for high-speed triggering, synchronization, and clocking. Refer to the *PXI Express Specification* for details.

The system timing slot also has a single-ended (PXI Star) trigger connected to every slot. Refer to Figure 3 for details.

The system timing slot has a pin (PXI\_CLK10\_IN) through which a system timing module can source a 10 MHz clock to which the backplane phase-locks. Refer to the *System Reference Clock* section for details.

The system timing slot has a pin (PXIe\_SYNC\_CTRL) through which a system timing module can control the PXIe\_SYNC100 timing. Refer to the *PXI Express Specification* and the *PXIe\_SYNC\_CTRL* section for details.

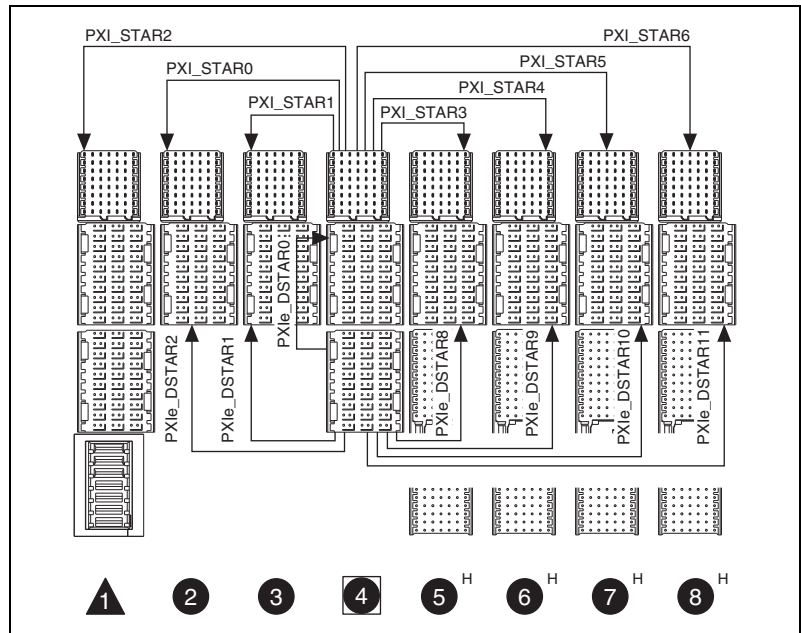

**Figure 3.** PXIe\_DSTAR and PXI Star Connectivity Diagram

## PXI Local Bus

The PXI backplane local bus is a daisy-chained bus that connects each peripheral slot with adjacent peripheral slots to the left and right.

The backplane routes PXI Local Bus 6 between adjacent PXI slots. The left local bus 6 from slot 1 is not routed anywhere, and the right local bus signal from slot 18 is not routed anywhere.

Local bus signals may range from high-speed TTL signals to analog signals as high as 42 V.

Initialization software uses the configuration information specific to each adjacent peripheral module to evaluate local bus compatibility.

## PXI Trigger Bus

All slots on the same PXI bus segment share eight PXI trigger lines. You can use these trigger lines in a variety of ways. For example, you can use triggers to synchronize the operation of several different PXI peripheral modules. In other applications, one module in the system timing slot can control carefully timed sequences of operations performed on other modules in the system. Modules can pass triggers to one another, allowing precisely timed responses to asynchronous external events the system is monitoring or controlling. Figure 4 shows the PXI trigger bus connectivity.

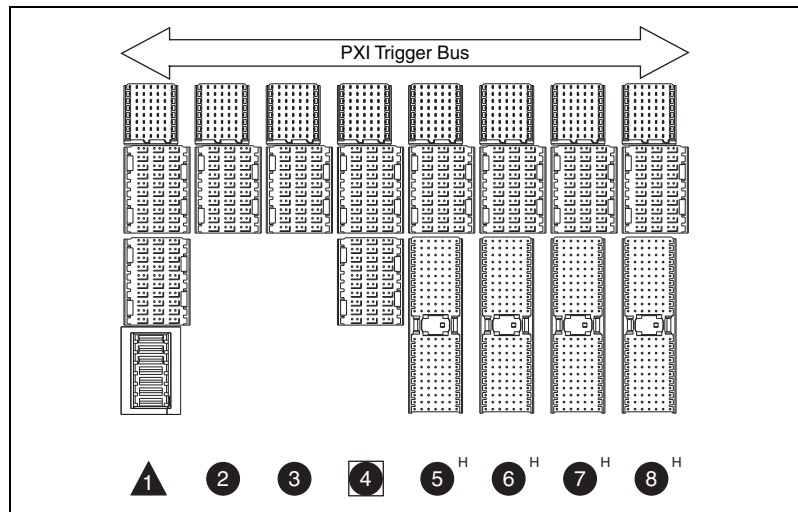

**Figure 4.** PXI Trigger Bus Connectivity Diagram

## System Reference Clock

The NI PXIe-1082 chassis supplies PXI\_CLK10, PXIe\_CLK100, and PXIe\_SYNC100 to every peripheral slot with an independent driver for each signal.

An independent buffer (having a source impedance matched to the backplane and a skew of less than 500 ps between slots) drives PXI\_CLK10 to each peripheral slot. You can use this common reference clock signal to synchronize multiple modules in a measurement or control system.

An independent buffer drives PXIe\_CLK100 to each peripheral slot. These clocks are matched in skew to less than 100 ps. The differential pair must be terminated on the peripheral with LVPECL termination for the buffer to drive PXIe\_CLK100 so that when there is no peripheral or a peripheral that does not connect to PXIe\_CLK100, no clock is being driven on the pair to that slot. Refer to Figure 5 for a termination example.

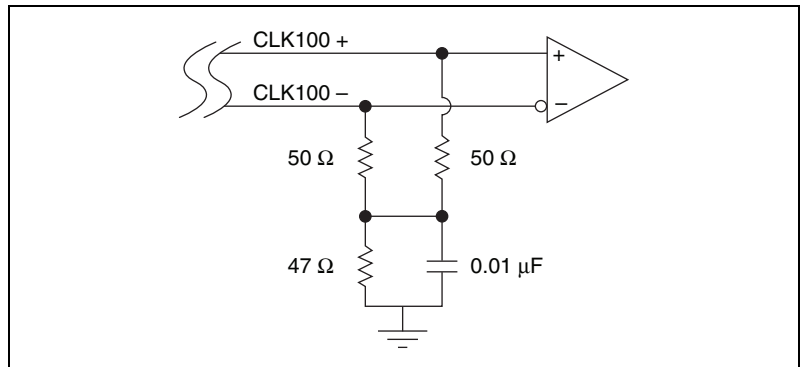

**Figure 5.** CLK100 Termination

An independent buffer drives PXIe\_SYNC100 to each peripheral slot. The differential pair must be terminated on the peripheral with LVPECL termination for the buffer to drive PXIe\_SYNC100 so that when there is no peripheral or a peripheral that does not connect to PXIe\_SYNC100, no SYNC100 signal is being driven on the pair to that slot. Refer to Figure 5 for a termination example.

In summary, PXI\_CLK10 is driven to every slot. PXIe\_CLK100 and PXIe\_SYNC100 are driven to every peripheral slot.



PXI\_CLK10, PXIe\_CLK100, and PXIe\_SYNC100 have the default timing relationship described in Figure 6.

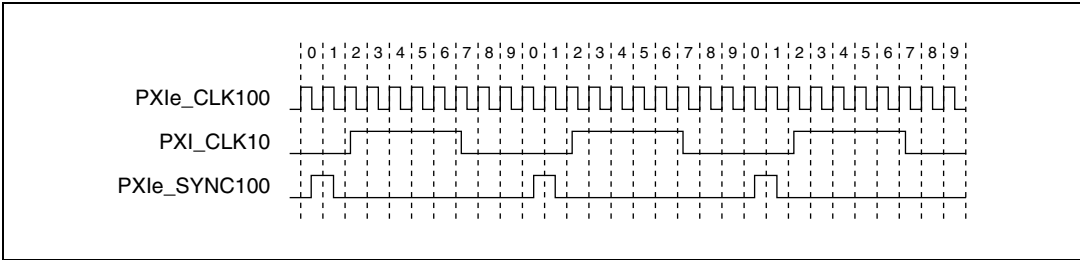

**Figure 6.** System Reference Clock Default Behavior

To synchronize the system to an external clock, you can drive PXI\_CLK10 from an external source through the PXI\_CLK10\_IN pin on the System Timing Slot. Refer to Table 10, *XP4 Connector Pinout for the System Timing Slot*, for the pinout. When a 10 MHz clock is detected on this pin, the backplane automatically phase-locks the PXI\_CLK10, PXIe\_CLK100, and PXIe\_SYNC100 signals to this external clock and distributes these signals to the slots. Refer to the *Backplane Specifications* section for the specification information for an external clock provided on the PXI\_CLK10\_IN pin of the system timing slot.

You also can drive a 10 MHz clock on connector J36. Refer to Figure 11 for the location of this connector. When a 10 MHz clock is detected on this connector, the backplane automatically phase-locks the PXI\_CLK10, PXIe\_CLK100, and PXIe\_SYNC100 signals to this external clock and distributes these signals to the slots. Refer to the *Backplane Specifications* section for the specification information for an external clock provided on J36.

If the 10 MHz clock is present on both the PXI\_CLK10\_IN pin of the System Timing Slot and connector J36, the signal on the System Timing Slot is selected. Refer to Table 1, which explains how the backplane selects the 10 MHz clocks.

**Table 1.** Backplane External Clock Input Truth Table

System Timing Slot PXI_CLK10_IN	J36 10 MHz REF IN	Backplane PXI_CLK10, PXIe_CLK100 and PXIe_SYNC100
No clock present	No clock present	Backplane generates its own clocks
No clock present	10 MHz clock present	PXI_CLK10, PXIe_CLK100 and PXIe_SYNC100 all phase-locked to J36—10 MHz REF IN
10 MHz clock present	No clock present	PXI_CLK10, PXIe_CLK100 and PXIe_SYNC100 all phase-locked to System Timing Slot—PXI_CLK10_IN
10 MHz clock present	10 MHz clock present	PXI_CLK10, PXIe_CLK100 and PXIe_SYNC100 all phase-locked to System Timing Slot—PXI_CLK10_IN

A copy of the backplane's PXI\_CLK10 is exported to connector J36. Refer to Figure 11 for the location of this connector. An independent buffer drives this clock. Refer to the [Backplane Specifications](#) section for the specification information for the 10 MHz REF OUT signal on J36.

## PXIe\_SYNC\_CTRL

PXIe\_SYNC100 is by default a 10 ns pulse synchronous to PXI\_CLK10. The frequency of PXIe\_SYNC100 is  $10/n$  MHz, where  $n$  is a positive integer. The default for  $n$  is 1, giving PXIe\_SYNC100 a 100 ns period. However, the backplane allows  $n$  to be programmed to other integers. For example, setting  $n = 3$  creates a PXIe\_SYNC100 with a 300 ns period while still maintaining its phase relationship to PXI\_CLK10. The  $n$  value can be any positive integer from 1 to 255.

The system timing slot has a control pin for PXIe\_SYNC100 called PXIe\_SYNC\_CTRL, for use when  $n > 1$ . Refer to Table 9, [XP3 Connector Pinout for the System Timing Slot](#), for the system timing slot pinout. Refer to the [Backplane Specifications](#) section for the PXIe\_SYNC\_CTRL input specifications.

By default, a high level detected by the backplane on the PXIe\_SYNC\_CTRL pin causes a synchronous restart for the PXIe\_SYNC100 signal. On the next PXI\_CLK10 edge, the PXIe\_SYNC100 signal restarts. This allows several chassis to have their PXIe\_SYNC100 in phase with each other. Refer to Figure 7 for timing details with this method.

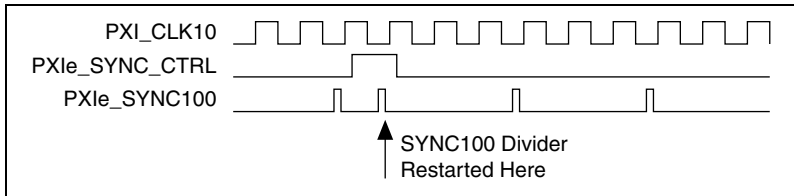

**Figure 7.** PXIe\_SYNC100 at 3.33 MHz Using PXIe\_SYNC\_CTRL as Restart

## Mechanical Requirements

---

### Mounting

Figure 8 shows the backplane dimensions. There are 22 holes available for mounting with M2.5 hardware.

Use all mounting holes for proper backplane support.

Eight mounting holes on top of the backplane have plated annular pads on the back of the backplane. Use these mounting holes to connect the backplane ground to the chassis in which the backplane is mounted. If you do not want to connect the backplane ground to the chassis, use insulated washers at these mounting holes. Refer to Figure 11 for the mounting hole positions.

# Dimensions

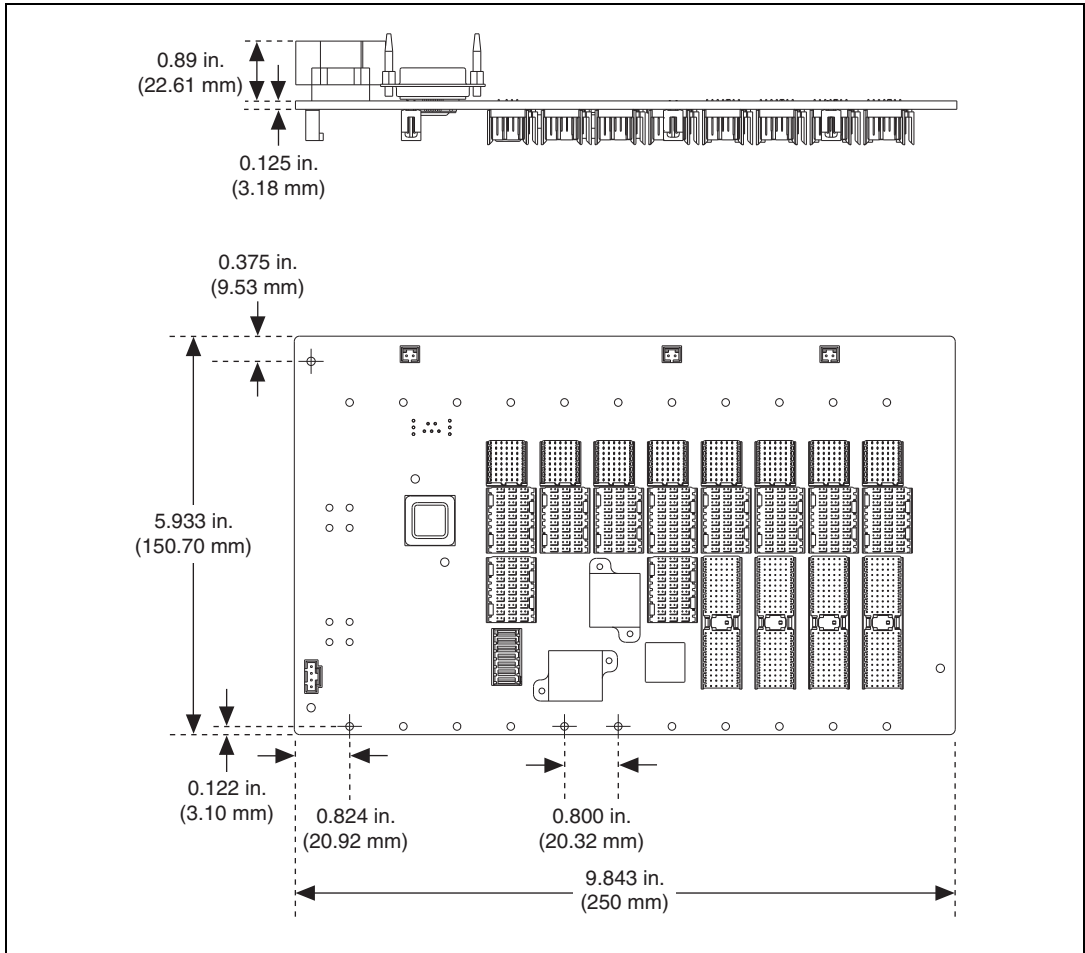

Figure 8. Dimensions

## Cooling



**Note** National Instruments is not responsible for damage to the backplane if inadequate cooling is used.

Airflow should be from the bottom to the top of the PXI modules. You must determine the airflow requirements for your system based on the *PXI Hardware Specification*.

The backplane must be adequately cooled to function reliably. Ensure that the components shown in Figure 9 are kept below their maximum case temperatures throughout the operating range.

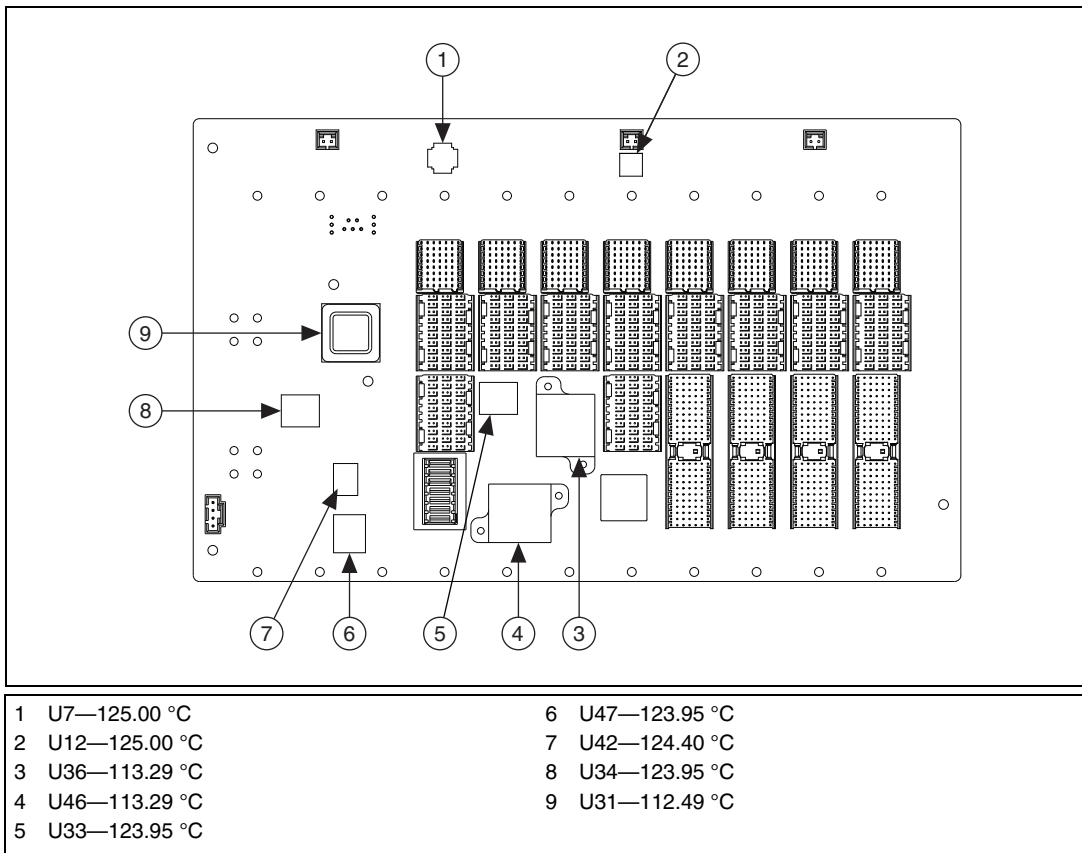

**Figure 9.** Thermally Relevant Component Recommended Maximum Operating Case Temperature (°C)

## Handling



**Caution** Be careful to avoid bending or otherwise damaging the pins on the backplane connectors. Bent pins may cause functional failures or damage when the backplane is powered.



**Caution** To protect both yourself and the backplane from electrical hazards, leave the chassis powered off until you finish installing the PXI controller and modules.



**Caution** Electrostatic discharge can damage your equipment. To avoid such damage, discharge the static built up on your body by touching a grounded metal object before handling the PXI equipment. Then touch the antistatic plastic package containing the backplane to a metal part of your PXI chassis before removing the backplane from the packaging.

# Electrical Requirements

## PXI Connectors

The PXI and PXI Express connectors have pin descriptions defined in the *PXI Hardware Specification* and *PXI Express Hardware Specification*. Figure 10 shows the connectors.

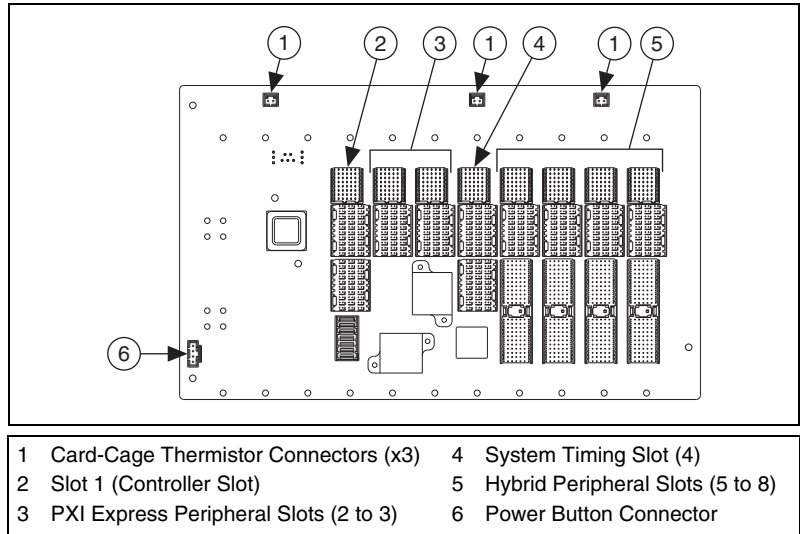

**Figure 10.** PXI Connectors

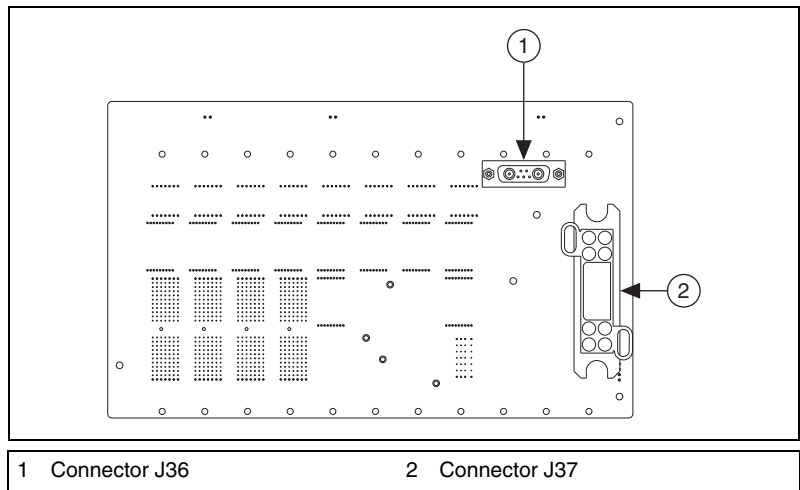

**Figure 11.** Backplane Power and J36 Connectors

# Power

Refer to the *PXI Express Hardware Specification* for power requirements and to the specifications of the chosen power supply to determine the minimum load required.

## Connector J37

Connector J37 is the NI PXIe-1082 backplane power supply connector. Figure 11 shows the J37 location. Refer to Table 2 for the pin descriptions. Connector J37 consists of eight #12 pins (1 to 4 and 26 to 29) for power. There also are 21 #20 pins (5 to 25) for mixed power and signaling. Table 2 also indicates which pins must be connected for basic backplane operation.

Refer to the CompactPCI Express specification for details regarding PS\_ON# and PS\_OK.



**Caution** Do not use the voltage sense pins (22, 23, and 25) to power the board. These pins are connected by thin trace to the backplane center and are for voltage sensing only. Providing current through these pins may damage the backplane. If your power supply has voltage sensing, use these pins; otherwise, leave them unconnected. Pins with “power plane” in the description are connected to the backplane’s internal power planes and are suitable for carrying current.



**Note** Tyco Electronics manufactures the J37 mating connector, which you can order with part number 298-08-01100.



**Note** The connector SMBus pins are connected to the backplane SMBus, which the CompactPCI Express specification defines. (The specification also defines uses and addressing.) Improper use of the SMBus could result in system controller malfunctions.

There are three SMBus slave devices on the NI PXIe-1082 backplane. The Backplane Descriptor EEPROM is at slave address  $A4_H$  as defined by the CompactPCI Express specification, and the backplane clocking CPLD is at slave address  $5A_H$ . There is a temperature monitoring device at slave address  $5C_H$ . If you must connect an SMBus slave device to the J37 SMBus pins, use slave address  $58_H$ .

**Table 2.** Connector J37 Pin Descriptions

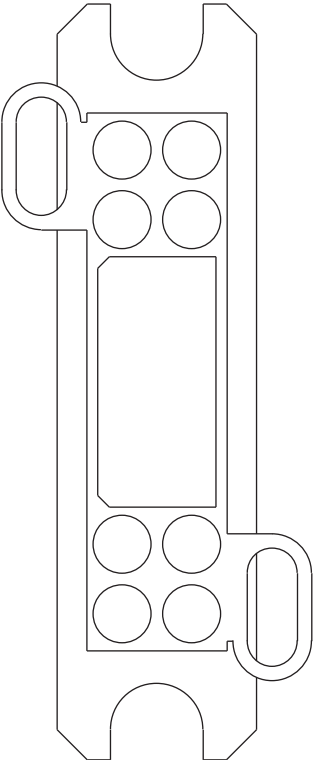
Connector	Pin	Signal	Description	Required for Basic Power Up
	1	+3.3V	+3.3 V power plane	Yes
	2	GND	Ground plane	Yes
	3	+3.3V	+3.3 V power plane	Yes
	4	GND	Ground plane	Yes
	5	5VAUX	5VAUX power plane	Yes
	6	GND	Ground plane	Yes
	7	-12V	-12 V power plane	Yes
	8	GND	Ground plane	Yes
	9	SMBCLK	Backplane SMBus clock	No
	10	SMBDAT	Backplane SMBus data	No
	11	SMBALERT#	Backplane SMBus alert#	No
	12	PS_ON#	From system slot J18—pin D2	No
	13	PS_OK	To system slot from power supply	Yes
	14	LED1	J35—pin 3	No
	15	LED2	J35—pin 4	No
	16	GND	Ground plane	Yes
	17	-12V	-12 V power plane	Yes
	18	GND	Ground plane	Yes
	19	OVERTEMP#	Alert of over-temperature condition in card cage	No
	20	12V_FAN	To pin 7 of test header W1	No
	21	GND	Ground plane	Yes
	22	+12V_SENSE	+12 V sense only, no power	No
	23	+3.3V_SENSE	+3.3 V sense only, no power	No
	24	GND	Ground plane	Yes
	25	+5V_SENSE	+5 V sense only, no power	No
	26	+12V	+12 V power plane	Yes
	27	GND	Ground plane	Yes

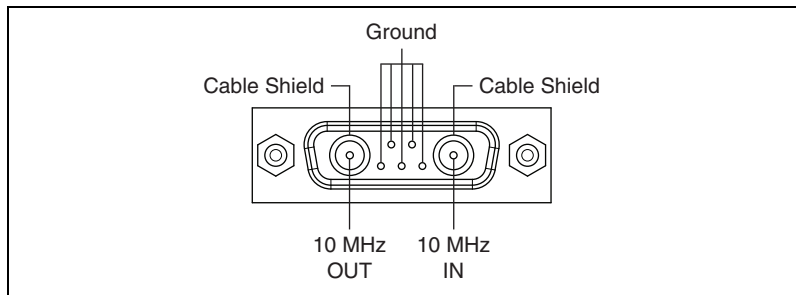

**Table 2.** Connector J37 Pin Descriptions (Continued)

Connector	Pin	Signal	Description	Required for Basic Power Up
	28	+5V	+5 V power plane	Yes
	29	GND	Ground plane	Yes

## Connector J36

Connector J36 is for interfacing with the backplane PXI\_CLK10 circuitry. Figure 11 shows the J36 connector location. Positronic manufactures the J36 mating connector, which you can order with part number CBD7W2M2000Z-759.1.

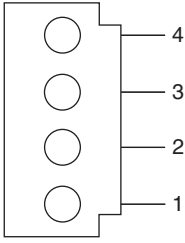

**Figure 12.** J36 Connector

## Connector J35

Use connector J35 in conjunction with J37 for interfacing with an inhibit switch and LED. You do not need to connect anything to J35 for basic backplane power up. Refer to Table 3 for the pin descriptions. The power button (PWRBTN#) signal is a momentary pushbutton signal that tells the system controller to enable or inhibit the power supply. You can use signals LED1 and LED2 to drive a bicolor LED in the power switch, but you also can use these signals to carry another digital signal.

**Table 3.** Connector J35 Pin Descriptions

Connector	Pin	Signal	Description
	1	PWRBTN#	Input to system slot J18—pin F2
	2	GND	Ground plane
	3	LED1	J37—pin 14
	4	LED2	J37—pin 15

## Connectors J2, J3, and J4

Use these connectors for three thermistors to monitor the card-cage temperature. You can use signal OVERTEMP# on J37 as an alarm indicating when the card-cage temperature exceeds 90 °C when used in conjunction with the four thermistors.



**Note** Use a Sensor Scientific KWM502C-6 or similar thermistor with these connectors.



**Note** The mating connector for J2, J3, and J4 is Molex part number 50-57-9402.

## Backplane Specifications

Size.....	3U-sized; one system slot (with three system expansion slots) and 7 peripheral slots. Compliant with IEEE 1101.10 mechanical packaging. PXI Express specification compliant. Accepts both PXI Express and CompactPCI (PICMG 2.0 R 3.0) 3U modules.
Backplane bare-board material .....	UL 94 V-0 Recognized
Backplane connectors .....	Conforms to IEC 917 and IEC 1076-4-101, and are UL 94 V-0 rated

# System Synchronization Clock (PXI\_CLK10, PXIe\_CLK100, PXIe\_SYNC100) Specifications

## 10 MHz System Reference Clock: PXI\_CLK10

Maximum slot-to-slot skew .....	500 ps
Accuracy .....	±25 ppm max (guaranteed over the operating temperature range)
Maximum jitter .....	5 ps RMS phase-jitter (10 Hz to 1 MHz range)
Duty-factor.....	45% to 55%
Unloaded signal swing.....	3.3 V ±0.3 V



**Note** For other specifications, refer to the *PXI-1 Hardware Specification*.

## 100 MHz System Reference Clock: PXIe\_CLK100 and PXIe\_SYNC100

Maximum slot-to-slot skew .....	100 ps
Accuracy .....	±25 ppm max (guaranteed over the operating temperature range)
Maximum jitter .....	3 ps RMS phase-jitter (10 Hz to 12 kHz range) 2 ps RMS phase-jitter (12 kHz to 20 MHz range)
Duty-factor for PXIe_CLK100.....	45% to 55%
Absolute single-ended voltage swing (When each line in the differential pair has 50 Ω termination to 1.30 V or Thévenin equivalent).....	400 to 1000 mV



**Note** For other specifications, refer to the *PXI-5 PXI Express Hardware Specification*.

## External 10 MHz Reference Out (on J36)

Accuracy .....	±25 ppm max (guaranteed over the operating temperature range)
Maximum jitter .....	5 ps RMS phase-jitter (10 Hz to 1 MHz range)

Output amplitude.....	1 V <sub>PP</sub> ±20% square-wave into 50 Ω 2 V <sub>PP</sub> unloaded
Output impedance .....	50 Ω ± 5 Ω

## External Clock Source

Frequency.....	10 MHz ±100 PPM
Input amplitude	
J36.....	200 mV <sub>PP</sub> to 5 V <sub>PP</sub> square-wave or sine-wave
System timing slot PXI_CLK10_IN.....	5 V or 3.3 V TTL signal
J36 input impedance.....	50 Ω ± 5 Ω
Maximum jitter introduced by backplane .....	1 ps RMS phase-jitter (10 Hz to 1 MHz range)

## PXIe\_SYNC\_CTRL

V <sub>IH</sub> .....	2.0 to 5.5 V
V <sub>IL</sub> .....	0 to 0.8 V

## PXI Star Trigger

Maximum slot-to-slot skew .....	250 ps
Backplane characteristic impedance .....	65 Ω ±10%



**Note** For PXI slot to PXI Star mapping, refer to the *System Timing Slot* section of Chapter 1, *Getting Started*, in the *NI PXIe-1082 User Manual*.



**Note** For other specifications, refer to the *PXI-1 Hardware Specification*.

## PXI Differential Star Triggers (PXIe-DSTARA, PXIe-DSTARB, PXIe-DSTARC)

Maximum slot-to-slot skew .....	150 ps
Maximum differential skew .....	25 ps
Backplane differential impedance.....	100 Ω ±10%



**Note** For PXI Express slot to PXI\_DSTAR mapping, refer to the *System Timing Slot* section of Chapter 1, *Getting Started*, in the *NI PXIe-1082 User Manual*.



**Note** For other specifications, the NI PXIe-1082 complies with the *PXI-5 PXI Express Hardware Specification*.

## Pinouts

---

This section describes the connector pinouts for the NI PXIe-1082 chassis backplane.

Table 4 shows the XP1 connector pinout for the System Controller slot.

Table 5 shows the XP2 Connector Pinout for the System Controller slot.

Table 6 shows the XP3 Connector Pinout for the System Controller slot.

Table 7 shows the XP4 Connector Pinout for the System Controller slot.

Table 8 shows the TP2 Connector Pinout for the System Timing slot.

Table 9 shows the XP3 Connector Pinout for the System Timing slot.

Table 10 shows the XP4 Connector Pinout for the System Timing slot.

Table 11 shows the P1 connector pinout for the Hybrid peripheral slots.

Table 12 shows the XP3 Connector Pinout for the Hybrid peripheral slots.

Table 13 shows the XP4 Connector Pinout for the Hybrid peripheral slots.

For more detailed information, refer to the *PXI-5 PXI Express Hardware Specification*, Revision 2.0. Contact the PXI Systems Alliance for a copy of the specification.

# System Controller Slot Pinouts

**Table 4.** XP1 Connector Pinout for the System Controller Slot

Pins	Signals
A	GND
B	3.3V
C	5V
D	GND
E	12V
F	12V
G	GND

**Table 5.** XP2 Connector Pinout for the System Controller Slot

Pin	A	B	ab	C	D	cd	E	F	ef
1	3PETp1	3PETn1	GND	3PERp1	3PERn1	GND	3PETp2	3PETn2	GND
2	3PETp3	3PETn3	GND	3PERp3	3PERn3	GND	3PERp2	3PERn2	GND
3	4PETp0	4PETn0	GND	4PERp0	4PERn0	GND	4PETp1	4PETn1	GND
4	4PETp2	4PETn2	GND	4PERp2	4PERn2	GND	4PERp1	4PERn1	GND
5	4PETp3	4PETn3	GND	4PERp3	4PERn3	GND	RSV	RSV	GND
6	RSV	RSV	GND	RSV	RSV	GND	RSV	RSV	GND
7	RSV	RSV	GND	RSV	RSV	GND	RSV	RSV	GND
8	RSV	RSV	GND	RSV	RSV	GND	RSV	RSV	GND
9	RSV	RSV	GND	RSV	RSV	GND	RSV	RSV	GND
10	RSV	RSV	GND	RSV	RSV	GND	RSV	RSV	GND

**Table 6.** XP3 Connector Pinout for the System Controller Slot

Pin	A	B	ab	C	D	cd	E	F	ef
1	RSV	RSV	GND	RSV	RSV	GND	RSV	RSV	GND
2	RSV	RSV	GND	PWR_OK	PS_ON#	GND	LINKCAP	PWRBTN#	GND
3	SMBDAT	SMBCLK	GND	4RefClk+	4RefClk-	GND	2RefClk+	2RefClk-	GND
4	RSV	PERST#	GND	3RefClk+	3RefClk-	GND	1RefClk+	1RefClk-	GND

**Table 6.** XP3 Connector Pinout for the System Controller Slot (Continued)

Pin	A	B	ab	C	D	cd	E	F	ef
5	1PETp0	1PETn0	GND	1PERp0	1PERn0	GND	1PETp1	1PETn1	GND
6	1PETp2	1PETn2	GND	1PERp2	1PERn2	GND	1PERp1	1PERn1	GND
7	1PETp3	1PETn3	GND	1PERp3	1PERn3	GND	2PETp0	2PETn0	GND
8	2PETp1	2PETn1	GND	2PERp1	2PERn1	GND	2PERp0	2PERn0	GND
9	2PETp2	2PETn2	GND	2PERp2	2PERn2	GND	2PETp3	2PETn3	GND
10	3PETp0	3PETn0	GND	3PERp0	3PERn0	GND	2PERp3	2PERn3	GND

**Table 7.** XP4 Connector Pinout for the System Controller Slot

Pin	Z	A	B	C	D	E	F
1	GND	GA4	GA3	GA2	GA1	GA0	GND
2	GND	5Vaux	GND	SYSEN#	WAKE#	ALERT#	GND
3	GND	RSV	RSV	RSV	RSV	RSV	GND
4	GND	RSV	RSV	RSV	RSV	RSV	GND
5	GND	PXI_TRIG3	PXI_TRIG4	PXI_TRIG5	GND	PXI_TRIG6	GND
6	GND	PXI_TRIG2	GND	RSV	PXI_STAR	PXI_CLK10	GND
7	GND	PXI_TRIG1	PXI_TRIG0	RSV	GND	PXI_TRIG7	GND
8	GND	RSV	GND	RSV	RSV	PXI_LBR6	GND

## System Timing Slot Pinouts

**Table 8.** TP2 Connector Pinout for the System Timing Slot

Pin	A	B	ab	C	D	cd	E	F	ef
1	PXIe_DSTARC0+	PXIe_DSTARC0-	GND	PXIe_DSTARC8+	PXIe_DSTARC8-	GND	PXIe_DSTARB8+	PXIe_DSTARB8-	GND
2	PXIe_DSTARA0+	PXIe_DSTARA0-	GND	PXIe_DSTARC9+	PXIe_DSTARC9-	GND	PXIe_DSTARA8+	PXIe_DSTARA8-	GND
3	PXIe_DSTARB0+	PXIe_DSTARB0-	GND	PXIe_DSTARC1+	PXIe_DSTARC1-	GND	PXIe_DSTARA9+	PXIe_DSTARA9-	GND
4	PXIe_DSTARB1+	PXIe_DSTARB1-	GND	PXI_STAR0	PXI_STAR1	GND	PXIe_DSTARB9+	PXIe_DSTARB9-	GND
5	PXIe_DSTARA1+	PXIe_DSTARA1-	GND	PXI_STAR2	PXI_STAR3	GND	PXIe_DSTARC10+	PXIe_DSTARC10-	GND
6	PXIe_DSTARC2+	PXIe_DSTARC2-	GND	PXI_STAR4	PXI_STAR5	GND	PXIe_DSTARA10+	PXIe_DSTARA10-	GND
7	PXIe_DSTARB2+	PXIe_DSTARB2-	GND	PXI_STAR6	NC	GND	PXIe_DSTARB10+	PXIe_DSTARB10-	GND
8	PXIe_DSTARA2+	PXIe_DSTARA2-	GND	NC	NC	GND	PXIe_DSTARC11+	PXIe_DSTARC11-	GND
9	NC	NC	GND	NC	NC	GND	PXIe_DSTARA11+	PXIe_DSTARA11-	GND
10	NC	NC	GND	NC	NC	GND	PXIe_DSTARB11+	PXIe_DSTARB11-	GND

**Table 9.** XP3 Connector Pinout for the System Timing Slot

Pin	A	B	ab	C	D	cd	E	F	ef
1	PXIe_CLK100+	PXIe_CLK100-	GND	PXIe_SYNC100+	PXIe_SYNC100-	GND	PXIe_DSTARC+	PXIe_DSTARC-	GND
2	PRSNT#	PWREN#	GND	PXIe_DSTARB+	PXIe_DSTARB-	GND	PXIe_DSTARA+	PXIe_DSTARA-	GND
3	SMBDAT	SMBCLK	GND	RSV	RSV	GND	RSV	RSV	GND
4	MPWRGD*	PERST#	GND	RSV	RSV	GND	1RefClk+	1RefClk-	GND
5	1PETp0	1PETn0	GND	1PERp0	1PERn0	GND	1PETp1	1PETn1	GND
6	1PETp2	1PETn2	GND	1PERp2	1PERn2	GND	1PERp1	1PERn1	GND
7	1PETp3	1PETn3	GND	1PERp3	1PERn3	GND	1PETp4	1PETn4	GND
8	1PETp5	1PETn5	GND	1PERp5	1PERn5	GND	1PERp4	1PERn4	GND
9	1PETp6	1PETn6	GND	1PERp6	1PERn6	GND	1PETp7	1PETn7	GND
10	RSV	RSV	GND	RSV	RSV	GND	1PERp7	1PERn7	GND

**Table 10.** XP4 Connector Pinout for the System Timing Slot

Pin	Z	A	B	C	D	E	F
1	GND	GA4	GA3	GA2	GA1	GA0	GND
2	GND	5Vaux	GND	SYSEN#	WAKE#	ALERT#	GND
3	GND	12V	12V	GND	GND	GND	GND
4	GND	GND	GND	3.3V	3.3V	3.3V	GND
5	GND	PXL_TRIG3	PXL_TRIG4	PXL_TRIG5	GND	PXL_TRIG6	GND
6	GND	PXL_TRIG2	GND	ATNLED	PXL_CLK10_IN	PXL_CLK10	GND
7	GND	PXL_TRIG1	PXL_TRIG0	ATNSW#	GND	PXL_TRIG7	GND
8	GND	PXIe_SYNC_CTRL	GND	RSV	PXL_LBL6	PXL_LBR6	GND

## Hybrid Slot Pinouts

**Table 11.** P1 Connector Pinout for the Hybrid Slot

Pin	Z	A	B	C	D	E	F
25	GND	5V	REQ64#	ENUM#	3.3V	5V	GND
24	GND	AD[1]	5V	V(I/O)	AD[0]	ACK64#	GND
23	GND	3.3V	AD[4]	AD[3]	5V	AD[2]	GND
22	GND	AD[7]	GND	3.3V	AD[6]	AD[5]	GND
21	GND	3.3V	AD[9]	AD[8]	M66EN	C/BE[0]#	GND
20	GND	AD[12]	GND	V(I/O)	AD[11]	AD[10]	GND
19	GND	3.3V	AD[15]	AD[14]	GND	AD[13]	GND



**Table 11.** P1 Connector Pinout for the Hybrid Slot (Continued)

Pin	Z	A	B	C	D	E	F
18	GND	SERR#	GND	3.3V	PAR	C/BE[1]#	GND
17	GND	3.3V	IPMB_SCL	IPMB_SDA	GND	PERR#	GND
16	GND	DEVSEL#	GND	V(I/O)	STOP#	LOCK#	GND
15	GND	3.3V	FRAME#	IRDY#	BD_SEL#	TRDY#	GND
12 to 14	Key Area						
11	GND	AD[18]	AD[17]	AD[16]	GND	C/BE[2]#	GND
10	GND	AD[21]	GND	3.3V	AD[20]	AD[19]	GND
9	GND	C/BE[3]#	IDSEL	AD[23]	GND	AD[22]	GND
8	GND	AD[26]	GND	V(I/O)	AD[25]	AD[24]	GND
7	GND	AD[30]	AD[29]	AD[28]	GND	AD[27]	GND
6	GND	REQ#	GND	3.3V	CLK	AD[31]	GND
5	GND	BRSVP1A5	BRSVP1B5	RST#	GND	GNT#	GND
4	GND	IPMB_PWR	HEALTHY#	V(I/O)	INTP	INTS	GND
3	GND	INTA#	INTB#	INTC#	5V	INTD#	GND
2	GND	TCK	5V	TMS	TDO	TDI	GND
1	GND	5V	-12V	TRST#	+12V	5V	GND

**Table 12.** XP3 Connector Pinout for the Hybrid Slot

Pin	A	B	ab	C	D	cd	E	F	ef
1	PXle_CLK100+	PXle_CLK100-	GND	PXle_SYNC100+	PXle_SYNC100-	GND	PXle_DSTARC+	PXle_DSTARC-	GND
2	PRSN#	PWREN#	GND	PXle_DSTARB+	PXle_DSTARB-	GND	PXle_DSTARA+	PXle_DSTARA-	GND
3	SMBDAT	SMBCLK	GND	RSV	RSV	GND	RSV	RSV	GND
4	MPWRGD*	PERST#	GND	RSV	RSV	GND	1RefClk+	1RefClk-	GND
5	1PETp0	1PETn0	GND	1PERp0	1PERn0	GND	1PETp1	1PETn1	GND
6	1PETp2	1PETn2	GND	1PERp2	1PERn2	GND	1PERp1	1PERn1	GND
7	1PETp3	1PETn3	GND	1PERp3	1PERn3	GND	1PETp4	1PETn4	GND
8	1PETp5	1PETn5	GND	1PERp5	1PERn5	GND	1PERp4	1PERn4	GND
9	1PETp6	1PETn6	GND	1PERp6	1PERn6	GND	1PETp7	1PETn7	GND
10	RSV	RSV	GND	RSV	RSV	GND	1PERp7	1PERn7	GND

**Table 13.** XP4 Connector Pinout for the Hybrid Slot

<b>Pin</b>	<b>Z</b>	<b>A</b>	<b>B</b>	<b>C</b>	<b>D</b>	<b>E</b>	<b>F</b>
1	GND	GA4	GA3	GA2	GA1	GA0	GND
2	GND	5Vaux	GND	SYSEN#	WAKE#	ALERT#	GND
3	GND	12V	12V	GND	GND	GND	GND
4	GND	GND	GND	3.3V	3.3V	3.3V	GND
5	GND	PXI_TRIG3	PXI_TRIG4	PXI_TRIG5	GND	PXI_TRIG6	GND
6	GND	PXI_TRIG2	GND	ATNLED	PXI_STAR	PXI_CLK10	GND
7	GND	PXI_TRIG1	PXI_TRIG0	ATNSW#	GND	PXI_TRIG7	GND
8	GND	RSV	GND	RSV	PXI_LBL6	PXI_LBR6	GND

Refer to the *NI Trademarks and Logo Guidelines* at [ni.com/trademarks](http://ni.com/trademarks) for more information on National Instruments trademarks. Other product and company names mentioned herein are trademarks or trade names of their respective companies. For patents covering National Instruments products/technology, refer to the appropriate location: **Help»Patents** in your software, the `patents.txt` file on your media, or the *National Instruments Patent Notice* at [ni.com/patents](http://ni.com/patents). You can find information about end-user license agreements (EULAs) and third-party legal notices in the readme file for your NI product. Refer to the *Export Compliance Information* at [ni.com/legal/export-compliance](http://ni.com/legal/export-compliance) for the National Instruments global trade compliance policy and how to obtain relevant HTS codes, ECCNs, and other import/export data.