

COMPREHENSIVE SERVICES

We offer competitive repair and calibration services, as well as easily accessible documentation and free downloadable resources.

SELL YOUR SURPLUS

We buy new, used, decommissioned, and surplus parts from every NI series. We work out the best solution to suit your individual needs.

 Sell For Cash  Get Credit  Receive a Trade-In Deal

OBSOLETE NI HARDWARE IN STOCK & READY TO SHIP

We stock **New**, **New Surplus**, **Refurbished**, and **Reconditioned** NI Hardware.



Bridging the gap between the manufacturer and your legacy test system.

 1-800-915-6216

 www.apexwaves.com

 sales@apexwaves.com

All trademarks, brands, and brand names are the property of their respective owners.

Request a Quote

 **CLICK HERE**

NI-6581

DEVICE SPECIFICATIONS

NI 6581/6581B Specifications

100 MHz Single-Ended High-Speed Digital I/O Adapter Module

This document lists specifications for the NI 6581/NI 6581B adapter module. Pair these specifications with the specifications listed in your NI FlexRIO FPGA specifications document. For more information about safety and electromagnetic compatibility, refer to the *Read Me First: Safety and Electromagnetic Compatibility* document included in your hardware kit or available at ni.com/manuals.



Caution To avoid permanent damage to the NI 6581/NI 6581B, disconnect all signals connected to the NI 6581/NI 6581B before powering down the module, and only connect signals after the module has been powered on by the NI FlexRIO FPGA module.



Note All numeric specifications are typical unless otherwise noted. All graphs illustrate the performance of a representative module.

The *NI 6581B* is compatible with all NI FlexRIO FPGA modules. The *NI 6581* variant is compatible with the NI PXI-795xR and NI PXIe-796xR FPGA modules only.

Specifications are subject to change without notice. For the most recent device specifications, visit ni.com/manuals.

Contents

How to Use Your NI FlexRIO Documentation Set.....	2
Channel Specifications per Connector.....	3
Generation Voltage Levels.....	4
Acquisition Voltage Levels.....	4
P0.<0..7>, P1.<0..7>, P2.<0..7>, and PFI<1..3>.....	5
CLOCK OUT.....	5
GLOBAL CLOCK <0..1>.....	5
Front Panel and Connector Pinouts.....	5
Power.....	8
Physical.....	9
Environment.....	9
Operating Environment.....	9
Storage Environment.....	9

Shock and Vibration..... 9

Compliance and Certifications..... 10

 Safety..... 10

 Electromagnetic Compatibility..... 10

 CE Compliance 10

 Online Product Certification..... 11

 Environmental Management..... 11

How to Use Your NI FlexRIO Documentation Set

Refer to the following flowchart for information about how to use FlexRIO documentation.

Figure 1. How to Use Your NI FlexRIO Documentation Set.

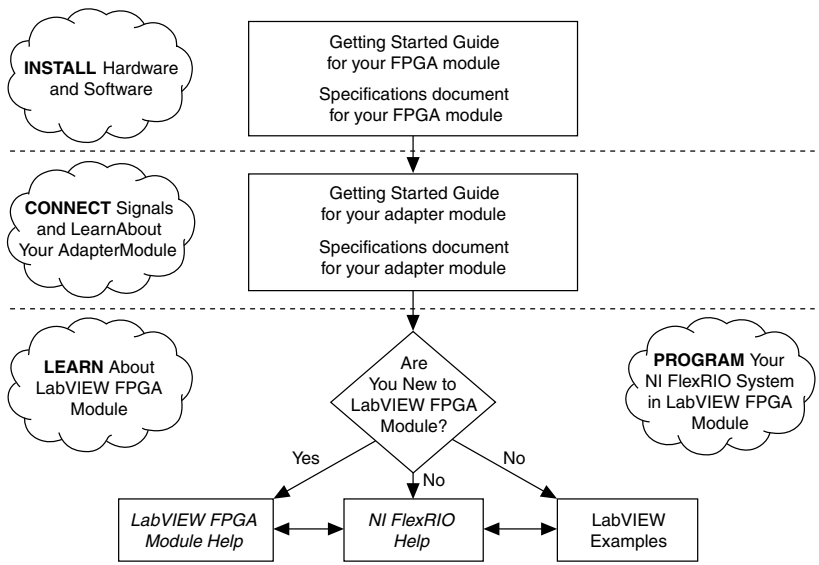

Table 1. NI FlexRIO Documentation Locations and Descriptions

Document	Location	Description
Getting started guide for your FPGA module	Available from the Start menu and at ni.com/manuals .	Contains installation instructions for your NI FlexRIO system.
Specifications document for your FPGA module	Available from the Start menu and at ni.com/manuals .	Contains specifications for your FPGA module.
Getting started guide for your adapter module	Available from the Start menu and at ni.com/manuals .	Contains signal information, examples, and CLIP details for your adapter module.

Table 1. NI FlexRIO Documentation Locations and Descriptions (Continued)

Document	Location	Description
Specifications document for your adapter module	Available from the Start menu and at ni.com/manuals .	Contains specifications for your adapter module.
<i>LabVIEW FPGA Module Help</i>	Embedded in <i>LabVIEW Help</i> and at ni.com/manuals .	Contains information about the basic functionality of the LabVIEW FPGA Module.
<i>NI FlexRIO Help</i>	Available from the Start menu and at ni.com/manuals .	Contains information about the FPGA module, adapter module, and CLIP configuration information.
LabVIEW Examples	Available in NI Example Finder. In LabVIEW, click Help»Find Examples»Hardware Input and Output»FlexRIO .	Contains examples of how to run FPGA VIs and Host VIs on your device.
IPNet	ni.com/ipnet	Contains LabVIEW FPGA functions and intellectual property to share.
NI FlexRIO product page	ni.com/flexrio	Contains product information and data sheets for NI FlexRIO devices.

Channel Specifications per Connector

Number of DDC connectors.....2, DDCA and DDCB

Number of digital I/O connectors.....54 total (48 data, 6 PFI), 27 per DDC connector

Direction control of data channels.....Configurable per 8-bit port (P0.<0..7>, P1.<0..7>, P2.<0..7>)

Direction control of PFI <1..3>.....All input or output, per port per connector



Note Digital I/O signals, P0.<0..7>, P1.<0..7>, P2.<0..7>, and PFI <1..3>, appear on both connectors, DDCA and DDCB.

Generation Voltage Levels

Table 2. P0.<0..7>, P1.<0..7>, P2.<0..7>, PFI <1..3>, and CLOCK OUT

Voltage	Low Voltage Levels		High Voltage Levels	
	Guaranteed	Typical	Guaranteed ²	Typical
5.0 V ³	0.55 V	0 V	3.8 V	5.0 V
3.3 V	0.55 V	0 V	2.4 V	3.3 V
2.5 V	0.30 V	0 V	1.9 V	2.5 V
1.8 V	0.45 V	0 V	1.2 V	1.8 V

 **Note** Each connector can be referenced to the external or internal power supply.

Acquisition Voltage Levels

Table 3. P0.<0..7>, P1.<0..7>, P2.<0..7>, PFI <1..3>, and GLOBAL CLOCK <0..1>

Voltage	Guaranteed Low Voltage Threshold ⁴	Guaranteed High Voltage Threshold ⁵
5.0 V ⁶	1.5 V	3.5 V
3.3 V	0.8 V	2.0 V
2.5 V	0.7 V	1.7 V
1.8 V	0.6 V	1.2 V

 **Note** Each connector can be referenced to an external or internal power supply.

 **Note** The I/O buffer performance on the NI 6581 is similar to the buffer performance specifications for the TI SN74LVC8T245 transceiver. The performance is correlated to supply voltage. I/O timing performance degrades as supply voltage decreases.

¹ Voltage levels guaranteed by design through the digital buffer specifications.

² Voltage levels guaranteed by design through the digital buffer specifications.

³ 5.0 V available only through an external power supply.

⁴ Voltage levels guaranteed by design through the digital buffer specification.

⁵ Voltage levels guaranteed by design through the digital buffer specification.

⁶ 5.0 V only available through an external power supply.

P0.<0..7>, P1.<0..7>, P2.<0..7>, and PFI<1..3>

Output impedance (nominal).....	50 Ω
Maximum input leakage.....	$\pm 6 \mu\text{A}$
Characteristic impedance.....	50 Ω traces
Power-on state.....	Drivers disabled
Absolute maximum input range.....	-0.5 to 6.5 V

CLOCK OUT

Output impedance (nominal).....	50 Ω series
Maximum output voltage range.....	1.8 V to 5.5 V, output only
Maximum toggle rate.....	100 MHz at ≥ 3.3 V

GLOBAL CLOCK <0..1>

Direction.....	Input into device ⁷
Maximum input leakage.....	$\pm 4 \mu\text{A}$
Characteristic impedance.....	50 Ω traces
Power-on state.....	Drivers disabled
Absolute maximum input range.....	-0.5 V to 6.5 V
Maximum toggle rate.....	100 MHz at ≥ 3.3 V

Front Panel and Connector Pinouts

The following figure shows the digital data connector (DDC) pin assignments for the NI 6581/6581B.

⁷ The clock is connected to NI FlexRIO FPGA module global clock inputs.

Figure 2. NI 6581/6581B Connector Pin Assignments

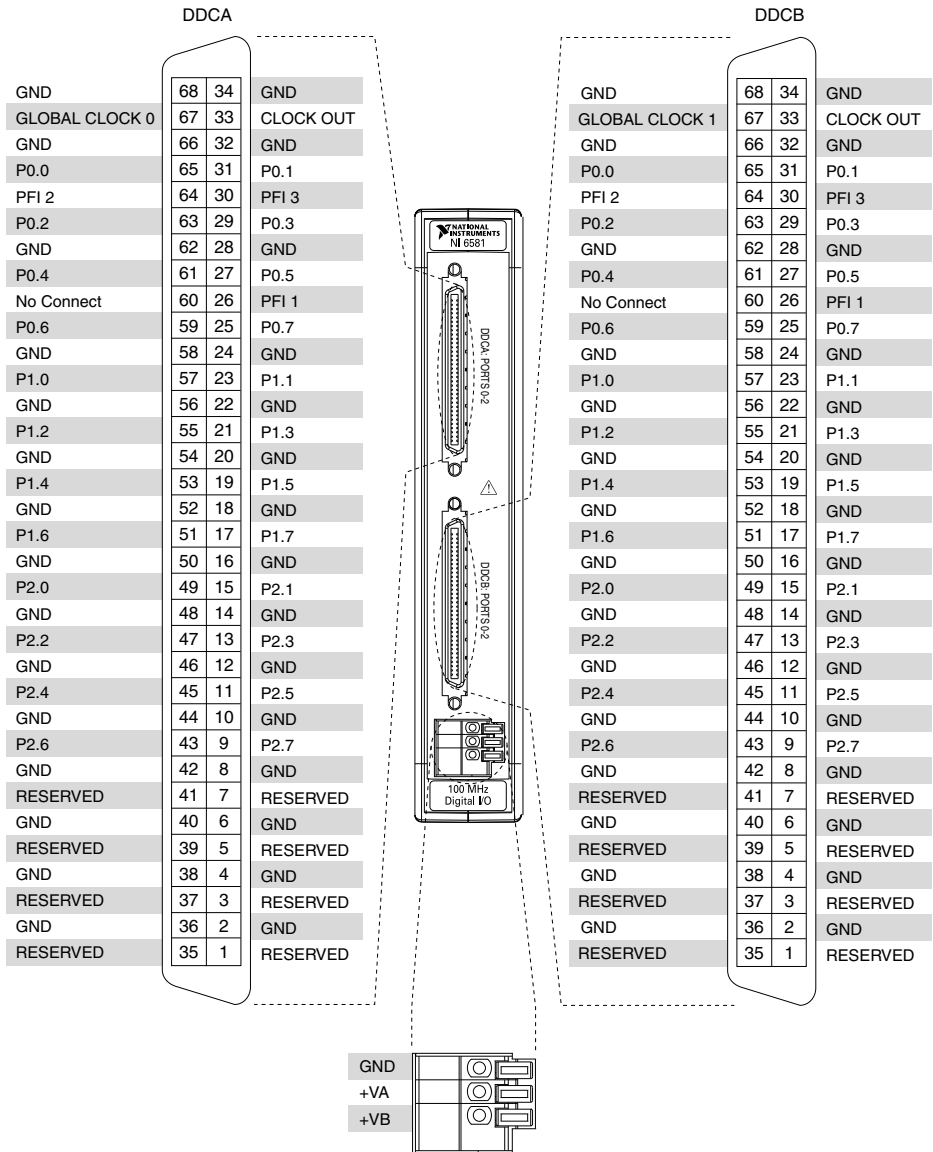

Note Connections that exceed any of the maximum ratings of input or output signals on the NI 6581/6581B can damage the device and the chassis. NI is not liable for any damage resulting from such signal connections.

Table 4. NI 6581 DDC Connector Pins

Signal Name	Pin(s)	Signal Type	Signal Description
GLOBAL CLOCK 0	67 on DDCA	Control	Input terminal for the external Sample Clock source, which can be used for dynamic acquisition.
GLOBAL CLOCK 1	67 on DDCB		
P0.<0..7>	25, 27, 29, 31, 59, 61, 63, 65	Data/Control	Bidirectional Port 0 digital I/O data channels 0 through 7.
P1.<0..7>	17, 19, 21, 23, 51, 53, 55, 57	Data/Control	Bidirectional Port 1 digital I/O data channels 0 through 7.
P0.<0..7>	9, 11, 13, 15, 43, 45, 47, 49	Data/Control	Bidirectional Port 2 digital I/O data channels 0 through 7.
CLOCK OUT	33	Control	Output terminal for the exported Sample Clock.
PFI <1..3>	26, 30, 64	Control/Data	Bidirectional digital I/O channels 1 through 3.
GND	2, 4, 6, 8, 10, 12, 14, 16, 18, 20, 22, 24, 28, 32, 34, 36, 38, 40, 42, 44, 46, 48, 50, 52, 54, 56, 58, 62, 66	Ground	Ground reference for signals.
RESERVED	1, 3, 5, 7, 35, 37, 39, 41	N/A	These terminals are reserved for future use. Do not connect to these pins.
No Connect	60	N/A	Do not connect to this pin.

The following table contains external power connector terminal information for the NI 6581.

Table 5. NI 6581 Power Connector Terminals

External Power Terminal Name	Terminal Description
GND	Ground reference for external power
+VA	External power terminal for DDCA connector.
+VB	External power terminal for DDCB connector.

The following table lists the NI 6581/6581B power supply control signals and the corresponding NI FlexRIO FPGA module signals.

Table 6. NI 6581/6581B Power Supply Control Signals and NI FlexRIO FPGA Module Signals

NI 6581/6581B Supply Control Signal Name	NI FlexRIO FPGA Module GPIO Out
BANK0_SUPPLY_SELECT	GPIO_32
BANK1_SUPPLY_SELECT	GPIO_32_n
PWR_SUPPLY_SEL_0	GPIO_65
PWR_SUPPLY_SEL_1	GPIO_65_n

Power

Internal power source

Power requirements from the NI FlexRIO
FPGA module

+3.3 V.....	200 mA, maximum
+12 V.....	250 mA, maximum

External power source

Voltage range.....	1.8 V to 5.5 V
Current.....	0.7 A at 3.3 V driving a 1 k load, all channels toggling with a PRBS pattern at full rate

Power dissipation

VA power + VB power.....	<5 W, maximum
Capacitance on +VA and.....	50 µF per rail
+VB	



Note With higher voltages, it is possible to exceed the power dissipation limit.

Maximum DC drive strength

5.0 V.....	32 mA
3.3 V.....	24 mA
2.5 V.....	8 mA
1.8 V.....	4 mA



Caution You must wait at least 10 ms after changing the power supply to allow the rails to settle to their new voltage before acquiring or generating data.

Physical

Dimensions.....	12.9 cm × 2.0 cm × 12.1 cm (5.1 in. × 0.8 in. × 4.7 in.)
Weight.....	284 g (10 oz)
Front panel connectors.....	Two 68-pin VHDCI connectors
Spring-terminal wiring.....	20 to 26 AWG copper conductor wire with 11 mm (0.43 in.) of insulation stripped from the end

Environment

Maximum altitude.....	2,000 m (800 mbar) (at 25 °C ambient temperature)
Pollution Degree.....	2
Indoor use only.	

Operating Environment

Ambient temperature range.....	0 °C to 55 °C (Tested in accordance with IEC-60068-2-1 and IEC-60068-2-2.)
Relative humidity range.....	10% to 90%, noncondensing (Tested in accordance with IEC-60068-2-56.)

Storage Environment

Ambient temperature range.....	-20 °C to 70 °C (Tested in accordance with IEC-60068-2-1 and IEC-60068-2-2.)
Relative humidity range.....	5% to 95%, noncondensing (Tested in accordance with IEC-60068-2-56.)

Shock and Vibration

Operating shock.....	30 g peak, half-sine, 11 ms pulse (Tested in accordance with IEC-60068-2-27. Meets MIL-PRF-28800F Class 2 limits.)
----------------------	--

Random vibration

Operating.....	5 Hz to 500 Hz, 0.3 g _{rms}
Nonoperating.....	5 Hz to 500 Hz, 2.4 g _{rms} (Tested in accordance with IEC-60068-2-64. Nonoperating test profile exceeds the requirements of MIL-PRF-28800F, Class 3.)

Compliance and Certifications

Safety

This product is designed to meet the requirements of the following electrical equipment safety standards for measurement, control, and laboratory use:

- IEC 61010-1, EN 61010-1
- UL 61010-1, CSA 61010-1



Note For UL and other safety certifications, refer to the product label or the [Online Product Certification](#) section.

Electromagnetic Compatibility

This product meets the requirements of the following EMC standards for electrical equipment for measurement, control, and laboratory use:

- EN 61326-1 (IEC 61326-1): Class A emissions; Basic immunity
- EN 55011 (CISPR 11): Group 1, Class A emissions
- AS/NZS CISPR 11: Group 1, Class A emissions
- FCC 47 CFR Part 15B: Class A emissions
- ICES-001: Class A emissions



Note In the United States (per FCC 47 CFR), Class A equipment is intended for use in commercial, light-industrial, and heavy-industrial locations. In Europe, Canada, Australia, and New Zealand (per CISPR 11), Class A equipment is intended for use only in heavy-industrial locations.



Note Group 1 equipment (per CISPR 11) is any industrial, scientific, or medical equipment that does not intentionally generate radio frequency energy for the treatment of material or inspection/analysis purposes.



Note For EMC declarations, certifications, and additional information, refer to the [Online Product Certification](#) section.

CE Compliance

This product meets the essential requirements of applicable European Directives, as follows:

- 2006/95/EC; Low-Voltage Directive (safety)
- 2004/108/EC; Electromagnetic Compatibility Directive (EMC)

Online Product Certification

To obtain product certifications and the DoC for this product, visit ni.com/certification, search by model number or product line, and click the appropriate link in the Certification column.

Environmental Management

NI is committed to designing and manufacturing products in an environmentally responsible manner. NI recognizes that eliminating certain hazardous substances from our products is beneficial to the environment and to NI customers.

For additional environmental information, refer to the *Minimize Our Environmental Impact* web page at ni.com/environment. This page contains the environmental regulations and directives with which NI complies, as well as other environmental information not included in this document.

Waste Electrical and Electronic Equipment (WEEE)



EU Customers At the end of the product life cycle, all products must be sent to a WEEE recycling center. For more information about WEEE recycling centers, National Instruments WEEE initiatives, and compliance with WEEE Directive 2002/96/EC on Waste Electrical and Electronic Equipment, visit ni.com/environment/weee.

电子信息产品污染控制管理办法（中国 RoHS）



中国客户 National Instruments 符合中国电子信息产品中限制使用某些有害物质指令 (RoHS)。关于 National Instruments 中国 RoHS 合规性信息，请登录 ni.com/environment/rohs_china。(For information about China RoHS compliance, go to ni.com/environment/rohs_china.)

Refer to the *NI Trademarks and Logo Guidelines* at ni.com/trademarks for information on National Instruments trademarks. Other product and company names mentioned herein are trademarks or trade names of their respective companies. For patents covering National Instruments products/technology, refer to the appropriate location: **Help»Patents** in your software, the `patents.txt` file on your media, or the *National Instruments Patent Notice* at ni.com/patents. You can find information about end-user license agreements (EULAs) and third-party legal notices in the readme file for your NI product. Refer to the *Export Compliance Information* at ni.com/legal/export-compliance for the National Instruments global trade compliance policy and how to obtain relevant HTS codes, ECCNs, and other import/export data. NI MAKES NO EXPRESS OR IMPLIED WARRANTIES AS TO THE ACCURACY OF THE INFORMATION CONTAINED HEREIN AND SHALL NOT BE LIABLE FOR ANY ERRORS. U.S. Government Customers: The data contained in this manual was developed at private expense and is subject to the applicable limited rights and restricted data rights as set forth in FAR 52.227-14, DFAR 252.227-7014, and DFAR 252.227-7015.

© 2010—2014 National Instruments. All rights reserved.