

COMPREHENSIVE SERVICES

We offer competitive repair and calibration services, as well as easily accessible documentation and free downloadable resources.

SELL YOUR SURPLUS

We buy new, used, decommissioned, and surplus parts from every NI series. We work out the best solution to suit your individual needs.

 Sell For Cash  Get Credit  Receive a Trade-In Deal

OBSOLETE NI HARDWARE IN STOCK & READY TO SHIP

We stock **New**, **New Surplus**, **Refurbished**, and **Reconditioned** NI Hardware.



Bridging the gap between the manufacturer and your legacy test system.

 1-800-915-6216

 www.apexwaves.com

 sales@apexwaves.com

All trademarks, brands, and brand names are the property of their respective owners.

Request a Quote

 **CLICK HERE**

PXIe-6544

GETTING STARTED GUIDE

NI PXIe-6544/6545/6547/6548

100/200 MHz Digital Waveform Generator/Analyzer



Note Before you begin, install and configure your chassis and controller.

This document explains how to install, configure, and test the NI PXIe-6544/6545/6547/6548 (NI 6544/6545/6547/6548). The NI 6544/6545/6547/6548 is a digital waveform generator/analyzer that features 32 bidirectional channels clocked at a maximum of 200 MHz.

To access NI 6544/6545/6547/6548 documentation, go to **Start»All Programs»National Instruments»NI-HSDIO»Documentation**.



Note The protection provided by the NI 6544/6545/6547/6548 may be impaired if it is used in a manner not described in this document.



Hot Surface If the NI 6544/6545/6547/6548 has been in use, the device may exceed safe handling temperatures and may cause discomfort. Allow the NI 6544/6545/6547/6548 to cool before touching the device or removing the device from the chassis.

Contents

Electromagnetic Compatibility Guidelines.....	2
Verifying the System Requirements.....	2
Unpacking the Kit.....	3
Kit Contents.....	3
Preparing the Environment.....	4
PXI Express Modules.....	4
Installing the Software.....	4
NI Script Editor.....	4
NI Digital Waveform Editor.....	5
Installing the NI 6544/6545/6547/6548.....	5
Connecting Signals.....	6
NI 6544/6545/6547/6548 Front Panels.....	6
Cabling Considerations.....	9
Connecting Accessories.....	10
Connecting a Custom Accessory.....	12
Wiring Considerations for Common Applications.....	12
Configuring the NI 6544/6545/6547/6548 in MAX.....	13
Using the Test Panel to Generate Digital Data.....	14
Using the Test Panel to Acquire Digital Data.....	15

Programming the NI-HSDIO.....	16
NI-HSDIO Examples.....	16
Troubleshooting.....	17
What Should I Do if the NI 6544/6545/6547/6548 Doesn't Appear in MAX?.....	17
What Should I Do if the Module Fails the Self-Test?.....	18
Why Is the ACCESS LED Off When the Chassis is On?.....	18
Where to Go Next.....	18
Worldwide Support and Services.....	19

Electromagnetic Compatibility Guidelines

This product was tested and complies with the regulatory requirements and limits for electromagnetic compatibility (EMC) stated in the product specifications. These requirements and limits provide reasonable protection against harmful interference when the product is operated in the intended operational electromagnetic environment.

This product is intended for use in industrial locations. However, harmful interference may occur in some installations, when the product is connected to a peripheral device or test object, or if the product is used in residential or commercial areas. To minimize interference with radio and television reception and prevent unacceptable performance degradation, install and use this product in strict accordance with the instructions in the product documentation.

Furthermore, any changes or modifications to the product not expressly approved by National Instruments could void your authority to operate it under your local regulatory rules.



Caution To ensure the specified EMC performance when connecting a cable to the Digital Data and Control (DDC) connector, install two snap-on, ferrite beads (NI part number 711627-01) included in the shipping kit onto the cable. Place one ferrite bead at each end of the cable, as close to the connector as practical.



Caution To ensure the specified EMC performance, operate this product only with shielded cables and accessories. Do not use unshielded cables or accessories unless they are installed in a shielded enclosure with properly designed and shielded input/output ports and connected to the product using a shielded cable. If unshielded cables or accessories are not properly installed and shielded, the EMC specifications for the product are no longer guaranteed.



Note To ensure the specified EMC performance, the length of all I/O cables must be no longer than 3 m (10 ft).

Verifying the System Requirements

To use the NI-HSDIO instrument driver, your system must meet certain requirements.

Refer to the product readme, which is available on the driver software media or online at ni.com/manuals, for more information about minimum system requirements, recommended system, and supported application development environments (ADEs).

Unpacking the Kit



Caution To prevent electrostatic discharge (ESD) from damaging the device, ground yourself using a grounding strap or by holding a grounded object, such as your computer chassis.

1. Touch the antistatic package to a metal part of the computer chassis.
2. Remove the device from the package and inspect the device for loose components or any other sign of damage.



Caution Never touch the exposed pins of connectors.



Note Do not install a device if it appears damaged in any way.

3. Unpack any other items and documentation from the kit.

Store the device in the antistatic package when the device is not in use.

Kit Contents

The kit contains the following items:

- NI-HSDIO instrument driver software media, which installs the following:
 - NI-HSDIO driver
 - NI Script Editor
 - *NI Digital Waveform Generator/Analyzer Help*
 - *NI PXIe-6544/6545/6547/6548 Getting Started Guide* (this document)
- NI Digital Waveform Editor software media
- NI 6544/6545/6547/6548 device
- snap-on ferrite beads (2x) (NI part number 711627-01)
- *Using Ferrites to Reduce High-Frequency Emissions Note to Users* document

Preparing the Environment

Ensure that the environment in which you are using the NI 6544/6545/6547/6548 meets the following specifications:

PXI Express Modules

Operating Environment

Ambient temperature range.....	0 °C to 55 °C (Tested in accordance with IEC 60068-2-1 and IEC 60068-2-2. Meets MIL-PRF-28800F Class 3 low temperature limit and MIL-PRF-28800F Class 2 high temperature limit.)
Relative humidity range.....	10% to 90%, noncondensing (Tested in accordance with IEC 60068-2-56.)
Maximum altitude.....	2,000 m (800 mbar) (at 25 °C ambient temperature)
Pollution Degree.....	2

Indoor use only.

Installing the Software

You must be an Administrator to install NI software on your computer.

1. Install an ADE, such as LabVIEW or LabWindows™/CVI™.
2. Insert the driver software media into your computer. The installer should open automatically.

If the installation window does not appear, navigate to the drive, double-click it, and double-click `autorun.exe`.

3. Follow the instructions in the installation prompts.



Note Windows users may see access and security messages during installation. Accept the prompts to complete the installation.

4. When the installer completes, select **Restart** in the dialog box that prompts you to restart, shut down, or restart later.

NI Script Editor

The NI Script Editor helps you develop linking and looping waveform generation operations.

The NI Script Editor is installed when you install NI-HSDIO. For more information, launch the NI Script Editor and select **Help»NI Script Editor Help** from the toolbar.

NI Digital Waveform Editor

The NI Digital Waveform Editor (NI DWE) allows you to create, edit, and import digital test vectors.



Note To use the NI DWE, install it after you install NI-HSDIO.

Installing the NI 6544/6545/6547/6548



Caution To prevent damage to the device caused by ESD or contamination, handle the device using the edges or the metal bracket.

1. Ensure the AC power source is connected to the chassis before installing the modules.

The AC power cord grounds the chassis and protects it from electrical damage while you install the modules.

2. Power off the chassis.
3. Inspect the slot pins on the chassis backplane for any bends or damage prior to installation. Do not install a module if the backplane is damaged.
4. Remove the black plastic connectors from all the captive screws on the module front panel.
5. Identify a supported slot in the chassis. The following figure shows the symbols that indicate the slot types.

Figure 1. Chassis Compatibility Symbols

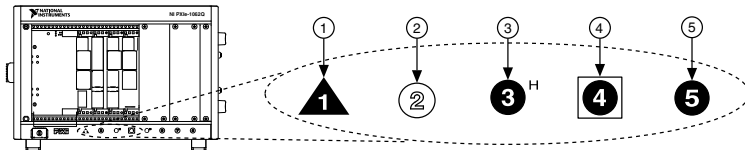

- | | |
|---------------------------------------|-----------------------------------|
| 1. PXI Express System Controller Slot | 4. PXI Express System Timing Slot |
| 2. PXI Peripheral Slot | 5. PXI Express Peripheral Slot |
| 3. PXI Express Hybrid Peripheral Slot | |

NI 6544/6545/6547/6548 modules can be placed in PXI Express peripheral slots, PXI Express hybrid peripheral slots, or PXI Express system timing slots.

6. Touch any metal part of the chassis to discharge static electricity.
7. Ensure that the ejector handle is in the unlatched (downward) position.
8. Place the module edges into the module guides at the top and bottom of the chassis. Slide the device into the slot until it is fully inserted.

Figure 2. Module Installation

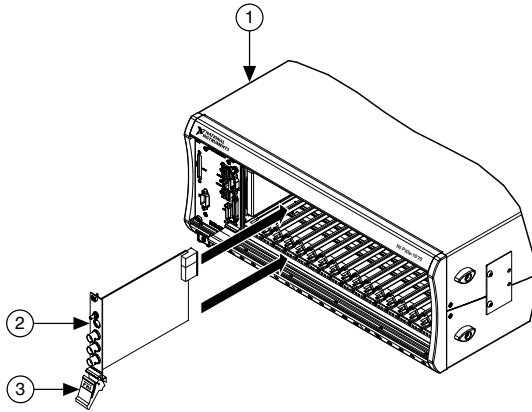

1. Chassis
2. Hardware Module
3. Ejector Handle in Down (Unlatched) Position

9. Latch the module in place by pulling up on the ejector handle.
10. Secure the device front panel to the chassis using the front-panel mounting screws.



Note Tightening the top and bottom mounting screws increases mechanical stability and also electrically connects the front panel to the chassis, which can improve the signal quality and electromagnetic performance.

11. Cover all empty slots using filler panels or slot blockers to maximize cooling air flow.
12. Power on the chassis.

Connecting Signals

NI 6544/6545/6547/6548 Front Panels

The NI 6544/6545/6547/6548 front panel exposes the following connections:

- Three SMA connectors named CLK IN, PFI 0, and CLK OUT
- One 68-pin VHDCI connector named DIGITAL DATA & CONTROL, or DDC

Figure 3. NI 6544/6545/6547/6548 Front Panel with VHDCI Connector Pinout

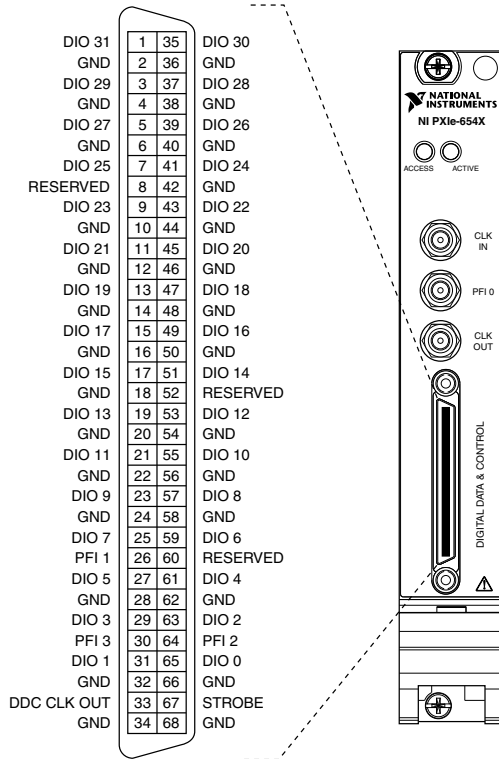

Table 1. NI 6544/6545/6547/6548 DDC Connector Pins

Pins	Signal Name	Signal Type	Signal Description
33	DDC_CLK OUT	Control	Output terminal for the exported Sample Clock.
67	Strobe	Control	Terminal for the external Sample clock source, which can be used for dynamic acquisition.

Table 1. NI 6544/6545/6547/6548 DDC Connector Pins (Continued)

Pins	Signal Name	Signal Type	Signal Description
1, 3, 5, 7, 9, 11, 13, 15, 17, 19, 21, 23, 25, 27, 29, 31, 35, 37, 39, 41, 43, 45, 47, 49, 51, 53, 55, 57, 59, 61, 63, 65	DIO <0..31>	Data	Bidirectional digital I/O data channels 0 through 31.
26, 30, 64	Programmable Function Interface (PFI) <1..3>	Control	Input terminals to the device for external triggers, or output terminals from the device for events.
2, 4, 6, 10, 12, 14, 16, 18, 20, 22, 24, 28, 32, 34, 36, 38, 40, 42, 44, 46, 48, 50, 54, 56, 58, 62, 66	GND	Ground	Ground reference for signals.
8, 52, 60	RESERVED	N/A	Terminals reserved for future use. Do not connect to these pins.

Table 2. NI 6544/6545/6547/6548 SMA Connectors

Connector	Signal Name	Signal Type	Description
CLK IN	Reference Clock Input	Control	Terminal for the external Reference clock used for the PLL or for the external Sample clock used for dynamic generation and/or acquisition.
PFI 0	PFI 0	Control	Single-ended input terminals to the device for static I/O, for external triggers, or for output terminals from the device for events. Refer to the device specifications for signal voltage levels.
CLK OUT	Reference Clock Output	Control	Terminal for the exported PLL Reference clock or the exported Sample clock.

Table 3. ACTIVE LED Indicators

Color	Indications
Off	Device not armed and not triggered.
Amber	Device armed and awaiting Start Trigger. If performing a dynamic acquisition operation, the device may be acquiring pretrigger samples.
Green	Device received Start Trigger.
Red	Error condition.

Table 4. ACCESS LED Indicators

Color	Indications
Off	Device not ready.
Amber	Device being accessed by software.
Green	Device ready to be programmed
Red	Running the niHSDIO Self Test VI or calling the niHSDIO_self_test function produced a failure.

Cabling Considerations

Cables for DDC connector



Caution To ensure the specified EMC performance when connecting a cable to the Digital Data and Control (DDC) connector, install the two snap-on, ferrite beads (NI part number 711627-01) included in the shipping kit onto the cable. Place one ferrite bead at each end of the cable, as close to the connector as practical.



Caution To ensure the specified EMC performance, operate this product only with shielded cables and accessories. Do not use unshielded cables or accessories unless they are installed in a shielded enclosure with properly designed and shielded input/output ports and connected to the product using a shielded cable. If unshielded cables or accessories are not properly installed and shielded, the EMC specifications for the product are no longer guaranteed.

Use one of the following cables for connections to the Digital Data and Control (DDC) connector on the NI 6544/6545/6547/6548.

- NI 6544/6545/6547/6548 shielded single-ended cable with individual microcoaxial 50 Ω lines for each signal
- NI 6544/6545/6547/6548 unshielded single-ended digital cable

- NI 6544/6545/6547/6548 shielded low-leakage cable. Use this cable if current leakage is a concern.
- NI 6544/6545/6547/6548 shielded flying lead cable

Figure 4. Single-Ended Flying Lead Cable Parts Locator Diagram

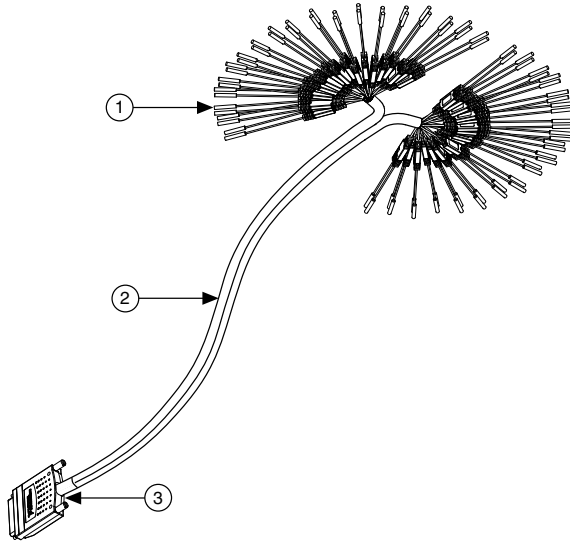

1. Lead Pairs
2. Removable Sleeving
3. 68-Pin VHDCI Connector



Note Always terminate cables properly to avoid improper measurements caused by signal reflections, overshoot, and undershoot. Refer to the *NI Digital Waveform Generator/Analyzer Help* for more information about signal termination.

Connecting Accessories

- Connect the NI CB-2162 single-ended digital I/O accessory to access the DDC connector on the device, to terminate the DIO channels on the device, or to develop a platform for prototyping circuits and testing DUTs. Refer to the following figure to connect the NI CB-2162 to the NI 6544/6545/6547/6548.



Caution To ensure the specified EMC performance, operate this product only with shielded cables and accessories. Do not use unshielded cables or accessories unless they are installed in a shielded enclosure with properly designed and shielded input/output ports and connected to the product using a

shielded cable. If unshielded cables or accessories are not properly installed and shielded, the EMC specifications for the product are no longer guaranteed.

Figure 5. Connecting the NI CB-2162 and an NI-HSDIO device

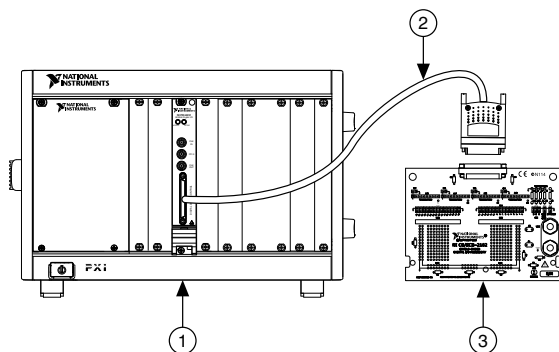

1. Chassis with NI-HSDIO device
2. NI SHC68-C68-D4 Cable
3. NI CB-2162 Accessory

- Connect the NI SMB-2163 accessory to the NI 6544/6545/6547/6548 in order to interface to other devices for testing and debugging. Refer to the following figure to connect the NI SMB-2163 to the NI 6544/6545/6547/6548.



Caution To ensure the specified EMC performance, operate this product only with shielded cables and accessories. Do not use unshielded cables or accessories unless they are installed in a shielded enclosure with properly designed and shielded input/output ports and connected to the product using a

shielded cable. If unshielded cables or accessories are not properly installed and shielded, the EMC specifications for the product are no longer guaranteed.

Figure 6. Connecting the NI SMB-2163 and an NI-HSDIO device

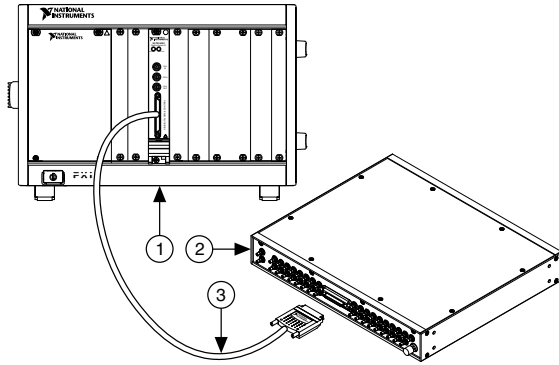

1. Chassis with NI-HSDIO device
2. NI SMB-2163 Accessory
3. NI SHC68-C68-D4 Cable

Connecting a Custom Accessory



Caution To ensure the specified EMC performance, operate this product only with shielded cables and accessories. Do not use unshielded cables or accessories unless they are installed in a shielded enclosure with properly designed and shielded input/output ports and connected to the product using a shielded cable. If unshielded cables or accessories are not properly installed and shielded, the EMC specifications for the product are no longer guaranteed.

Many common NI digital waveform generator/analyzer applications require you to create a custom accessory to access the signals of your device under test (DUT).

To connect a custom accessory to the VHDCI DDC connector on the NI 6544/6545/6547/6548, purchase a mating connector for the VHDCI cable from NI.

For more information, refer to the *Interfacing to the NI Digital Waveform Generator/Analyzer using the VHDCI Connector* application note, available by entering the info code `rdinwa` at ni.com/info.

Wiring Considerations for Common Applications

Dynamic Generation Wiring Considerations

You may need additional parallel termination resistance at the destination for optimal signal quality during dynamic generation, depending on the loading of the device under test (DUT). Refer to the *NI Digital Waveform Generator/Analyzer Help* for information about signal

termination. The following figure shows how the NI 6544/6545/6547/6548 generates data through a matched impedance system.

Figure 7. Dynamic Generation Functional Diagram

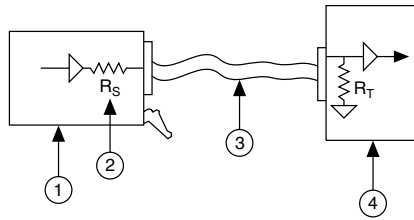

- | | |
|------------------------------------|----------------------------|
| 1. NI-HSDIO device | 3. 50 Ω cable |
| 2. 50 Ω source impedance (R_s) | 4. Device under test (DUT) |

Dynamic Acquisition Wiring Considerations

During dynamic acquisition, the device under test (DUT) generating the signals must have a matched source impedance as close to 50 Ω as possible in order to minimize signal reflections and maintain optimal signal quality. The following figure shows how the NI 6544/6545/6547/6548 acquires data through a matched impedance system. Refer to the specifications document for your device for supported input impedances (R_T).

Figure 8. Dynamic Acquisition Functional Diagram

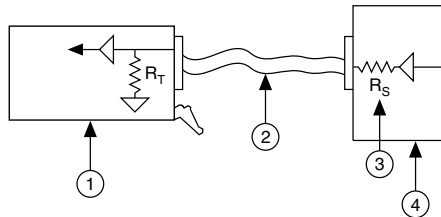

- | | |
|--------------------|------------------------------------|
| 1. NI-HSDIO device | 3. 50 Ω source impedance (R_s) |
| 2. 50 Ω cable | 4. Device under test (DUT) |

Configuring the NI 6544/6545/6547/6548 in MAX

Use Measurement & Automation Explorer (MAX) to configure your National Instruments hardware. MAX informs other programs about which devices reside in the system and how they are configured. MAX is automatically installed with NI-HSDIO.

1. Launch MAX.

2. In the configuration tree, double-click **Devices and Interfaces** to see the list of installed devices.



Note If you are using the NI 6544/6545/6547/6548 with the LabVIEW Real-Time Module, expand **Remote Systems**. Find your target IP address or name, expand it, and then expand **Devices and Interfaces**.

3. Expand your **Chassis** tree item.

MAX lists all devices installed in the chassis. Your default device names may vary.



Note If you do not see your device listed, press <F5> to refresh the list of installed devices. If the device is still not listed, power off the system, ensure the device is correctly installed, and restart.

4. Record the device identifier MAX assigns to the hardware. Use this identifier when programming the NI 6544/6545/6547/6548.
5. Self-test the device by selecting the device in the configuration tree and clicking **Self-Test** in the MAX toolbar.

The MAX self-test performs a basic verification of hardware resources.

Using the Test Panel to Generate Digital Data

To verify your device configuration, use the device test panel in MAX to generate simple digital data using the NI 6544/6545/6547/6548.

1. Remove any signal connections to the device.
2. Right-click the device under the appropriate **Chassis**, and select **Test Panels**.
3. Select the **Dynamic** tab on the side of the pane.
4. Click **Select All** to select all of your channels. The digital waveform now appears in the graph.
5. Enter the frequency in the **Clock Frequency** control, located on the left side of the test panel.
6. Enter values for the generation and acquisition voltages in the controls below the **Clock Frequency** control. You can enter **High** and **Low** values to create your own custom levels for the device.
7. Choose a fill pattern. The following figure shows the pattern control and the first few signals in the window.

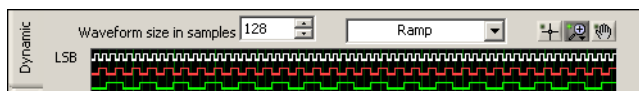

Note When generating a Marching Ones or Marching Zeroes waveform, make the waveform size a multiple of the number of selected channels.

8. Click **Play** to generate the waveform shown in the graph on the selected channels. The default generation option is **Continuous**, but you can toggle this setting using the control below the graph.

Because the data channels on the NI 6544/6545/6547/6548 are bidirectional, while the data is being continuously generated on all of the channels, as in the previous step, you can acquire the data being generated.



Note Refer to the specifications document for information about the setup and hold times and propagation delays associated with generation operations of the device. At some frequencies, generating data on the same channels when no cable is attached to the DIGITAL DATA & CONTROL (DDC) connector violates these timing parameters and results in incorrectly sampled data. For information, refer to the *NI Digital Waveform Generator/Analyzer Help*.

Using the Test Panel to Acquire Digital Data

To verify your device configuration, use the device test panel in MAX to acquire simple digital data using the NI 6544/6545/6547/6548.

1. Click the **Acquisition** tab.
2. Click **Play**.

The device acquires the digital data that you generated in the previous steps, and the data is displayed on the graph.

3. Click **Close** when you are finished.

Programming the NI-HSDIO

You can generate or acquire data using the NI-HSDIO instrument driver to program the NI 6544/6545/6547/6548 in the supported ADE of your choice.

Table 5. NI 6544/6545/6547/6548 Programming Options

Application Programming Interface (API)	Location	Description
NI-HSDIO Instrument Driver	LabVIEW—Available on the LabVIEW Functions palette at Measurement I/O»NI-HSDIO .	NI-HSDIO configures and operates the device hardware and performs basic waveform generation and acquisition using LabVIEW VIs or LabWindows/CVI functions.
	C or LabWindows/CVI—Available at Program Files»IVI Foundation»IVI»Drivers»niHSDIO .	
	Microsoft Visual C/C++—Use examples located in the <code><NIDocDir>\NI-HSDIO\examples</code> directory, where <code><NIDocDir></code> is one of the following directories: <ul style="list-style-type: none"> • Windows 8/7/Vista—Users\Public\Documents\National Instruments • Windows XP—Documents and Settings\All Users\Shared Documents\National Instruments 	You can modify an NI-HSDIO C example to create an application with Microsoft Visual C/C++. Copy an NI-HSDIO example to copy required project settings for include paths and library files. Alternatively, refer to the <i>Creating an Application with Microsoft Visual C and C++</i> topic of the <i>NI Digital Waveform Generator/Analyzer Help</i> to manually add all required include and library files to your project.

NI-HSDIO Examples

To locate programming examples, refer to the following table.

Table 6. NI-HSDIO Example Locations

Application Development Environment (ADE)	Location
LabVIEW or LabWindows/CVI	Within LabVIEW or LabWindows/CVI, select Help»Find Examples , and navigate to Hardware Input and Output»Modular Instruments .
ANSI C	Available at <code><NIDocDir>\NI-HSDIO\examples\</code> directory, where <code><NIDocDir></code> is one of the following directories: <ul style="list-style-type: none"> • Windows 8/7/Vista—Users\Public\Public Documents\National Instruments • Windows XP—Documents and Settings\All Users\Shared Documents\National Instruments

Troubleshooting

If an issue persists after you complete a troubleshooting procedure, contact NI technical support or visit ni.com/support.

What Should I Do if the NI 6544/6545/6547/6548 Doesn't Appear in MAX?

1. In the MAX configuration tree, click **Devices and Interfaces**.
2. Expand the **Chassis** tree to see the list of installed devices, and press <F5> to refresh the list.
3. If the module is still not listed, power off the system, ensure that all hardware is correctly installed, and restart the system.
4. Navigate to the Device Manager.

Operating System	Description
Windows 8	Right-click the Start screen, and select All apps»Control Panel»Hardware and Sound»Device Manager .
Windows 7	Select Start»Control Panel»Device Manager .
Windows Vista	Select Start»Control Panel»System and Maintenance»Device Manager .
Windows XP	Select Start»Control Panel»System»Hardware»Device Manager .

5. If you are using a PXI controller, verify that a **National Instruments** entry appears in the system device list. Reinstall NI-HSDIO and the device if error conditions appear in the list. If you are using an MXI controller, right-click **PCI-to-PCI Bridge**, and select **Properties** from the shortcut menu to verify that the bridge is enabled.

What Should I Do if the Module Fails the Self-Test?

1. Restart the system.
2. Launch MAX, and perform the self-test again.
3. Power off the chassis.
4. Reinstall the failed module in a different slot.
5. Power on the chassis.
6. Perform the self-test again.

Why Is the ACCESS LED Off When the Chassis is On?

The LEDs may not illuminate until the device has been configured in MAX. Before proceeding, verify that the NI 6544/6545/6547/6548 appears in MAX.

If the ACCESS LED fails to illuminate after you power on the PXI Express chassis, a problem may exist with the PXI Express power rails, a hardware module, or the LED.

1.  **Caution** Apply external signals only while the NI 6544/6545/6547/6548 is powered on. Applying external signals while the device is powered off may cause damage.
Disconnect any signals from the PXI Express module front panels.
2. Remove any front panel connections from the NI 6544/6545/6547/6548.
3. Power off the PXI Express chassis.
4. Remove the module from the PXI Express chassis and inspect it for damage. Do not reinstall a damaged device.
5. Install the module in a different PXI Express chassis slot from which you removed it.
6. Power on the PXI Express chassis.
7. Verify that the device appears in MAX.
8. Reset the device in MAX and perform a self-test.

If the ACCESS LED still fails to illuminate and failures continue, contact NI technical support or visit ni.com/support.

Where to Go Next

The following figure describes additional documentation and resources as you develop an application with the NI 6544/6545/6547/6548.

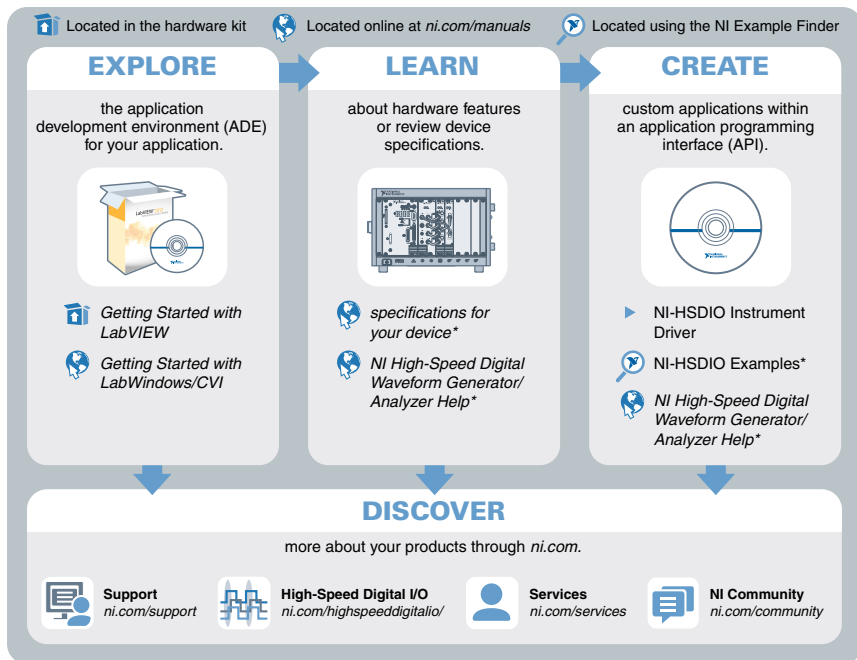

Worldwide Support and Services

The National Instruments website is your complete resource for technical support. At ni.com/support, you have access to everything from troubleshooting and application development self-help resources to email and phone assistance from NI Application Engineers.

Visit ni.com/services for NI Factory Installation Services, repairs, extended warranty, and other services.

Visit ni.com/register to register your National Instruments product. Product registration facilitates technical support and ensures that you receive important information updates from NI.

A Declaration of Conformity (DoC) is our claim of compliance with the Council of the European Communities using the manufacturer's declaration of conformity. This system affords the user protection for electromagnetic compatibility (EMC) and product safety. You can obtain the DoC for your product by visiting ni.com/certification. If your product supports calibration, you can obtain the calibration certificate for your product at ni.com/calibration.

National Instruments corporate headquarters is located at 11500 North Mopac Expressway, Austin, Texas, 78759-3504. National Instruments also has offices located around the world. For telephone support in the United States, create your service request at ni.com/support or

dial 1 866 ASK MYNI (275 6964). For telephone support outside the United States, visit the *Worldwide Offices* section of ni.com/niglobal to access the branch office websites, which provide up-to-date contact information, support phone numbers, email addresses, and current events.

Refer to the *NI Trademarks and Logo Guidelines* at ni.com/trademarks for information on National Instruments trademarks. Other product and company names mentioned herein are trademarks or trade names of their respective companies. For patents covering National Instruments products/technology, refer to the appropriate location: **Help»Patents** in your software, the `patents.txt` file on your media, or the *National Instruments Patent Notice* at ni.com/patents. You can find information about end-user license agreements (EULAs) and third-party legal notices in the readme file for your NI product. Refer to the *Export Compliance Information* at ni.com/legal/export-compliance for the National Instruments global trade compliance policy and how to obtain relevant HTS codes, ECCNs, and other import/export data. NI MAKES NO EXPRESS OR IMPLIED WARRANTIES AS TO THE ACCURACY OF THE INFORMATION CONTAINED HEREIN AND SHALL NOT BE LIABLE FOR ANY ERRORS. U.S. Government Customers: The data contained in this manual was developed at private expense and is subject to the applicable limited rights and restricted data rights as set forth in FAR 52.227-14, DFAR 252.227-7014, and DFAR 252.227-7015.

© 2004—2015 National Instruments. All rights reserved.

375089A-01 Jun15