

COMPREHENSIVE SERVICES

We offer competitive repair and calibration services, as well as easily accessible documentation and free downloadable resources.

SELL YOUR SURPLUS

We buy new, used, decommissioned, and surplus parts from every NI series. We work out the best solution to suit your individual needs.

 Sell For Cash  Get Credit  Receive a Trade-In Deal

OBSOLETE NI HARDWARE IN STOCK & READY TO SHIP

We stock **New**, **New Surplus**, **Refurbished**, and **Reconditioned** NI Hardware.



Bridging the gap between the manufacturer and your legacy test system.

 1-800-915-6216

 www.apexwaves.com

 sales@apexwaves.com

All trademarks, brands, and brand names are the property of their respective owners.

Request a Quote

 **CLICK HERE**

PXIe-6674T

CALIBRATION PROCEDURE

NI PXIe-6674T

This document describes how to write a calibration procedure for the 10 MHz oscillator frequency of the NI PXIe-6674T timing and synchronization modules.

Contents

Software.....	1
Documentation.....	1
Calibration Interval.....	2
Password.....	2
Test Equipment.....	2
Test Conditions.....	2
Calibration Procedure.....	2
Initial Setup.....	3
Verification.....	3
Connecting the Clock Source.....	3
Measuring the Frequency.....	5
Adjustment.....	7
Reverification.....	9
Worldwide Support and Services.....	10

Software

This calibration procedure requires NI-Sync and NI-VISA. NI-Sync and NI-VISA support a number of application development environments (ADEs) and programming languages, including LabVIEW, LabWindows™/CVI™, and Microsoft Visual C++. When you install the drivers, you need to install support for only the ADE or programming language you are using.

Documentation

You need the *NI-Sync User Manual* to calibrate the NI PXIe-6674T.

The *NI-Sync User Manual* contains detailed information about using the NI-Sync driver, including information about installing NI-Sync and creating applications that use the NI-Sync driver. These sources, along with this document, are your primary references for writing your calibration utility. You also can refer to the documentation for the programming language or application development environment you are using. For further information about the device you are calibrating, refer to the *NI PXIe-6674T User Manual*.

Calibration Interval

The measurement requirements of the application determine how often you should calibrate the device to ensure its accuracy. National Instruments recommends that you calibrate the NI PXIe-6674T *yearly*. You may want to shorten this interval based on the application demands.

Password

The default password for password-protected operations is NI.

Test Equipment

Calibrating the NI PXIe-6674T requires the following equipment.

Equipment	Recommended Model	Requirements
10 MHz clock source	Symmetrcom/Datum 8040	Accurate to within 0.75 parts-per-billion (ppb)
BNC-SMA cable	—	—
PXI Express chassis	NI PXIe-1062Q, NI PXIe-1075, NI PXIe-1082, NI PXIe-1085, NI PXIe-1086	Must have a system timing slot

Test Conditions

- Install the NI PXIe-6674T in the system timing slot of the PXI Express chassis. The calibration procedure requires features of PXI Express that are accessible only in the system timing slot.
- Maintain a temperature of approximately $23\text{ }^{\circ}\text{C} \pm 5\text{ }^{\circ}\text{C}$.
- Keep relative humidity below 80 percent.
- Use shielded copper wire for all cable connections to the device.
- Ensure the NI PXIe-6674T has been continuously powered for at least 24 hours prior to calibration to allow the 10 MHz oscillator frequency to stabilize.
- Keep PXI Express chassis filters clean and fan speed set to High.
- Ensure the frequency reference has been continuously powered, as specified by its manual, for its accuracy to be within 0.75 parts-per-billion (ppb) prior to calibration.

Calibration Procedure

The steps used in the calibration procedure are as follows:

1. Initial setup.
2. Verification.

3. Adjustment.
4. Reverification.

Initial Setup

Complete the following steps to set up the NI PXIe-6674T for calibration.

1. Make sure the PXI Express chassis involved in the calibration procedure is powered off.
2. Install the NI PXIe-6674T board into the system timing slot of your chassis.



Note The module *must* be installed in the system timing slot of the chassis.

3. Power on the PXI Express chassis.
4. Make sure that all the appropriate driver and application software is installed on the host computer.
5. Configure the hardware properly with Measurement & Automation Explorer (MAX). Refer to the *NI PXIe-6674T Installation Guide* for details about configuring the PXI Express equipment.

Verification

The following steps outline the procedure for measuring the 10 MHz oscillator frequency on the NI PXIe-6674T and determining whether the device requires adjustment to meet the published specifications.

Connecting the Clock Source

1. Connect the external 10 MHz reference source to the CLKIN connector on the NI PXIe-6674T.
2. Program the NI PXIe-6674T to route the CLKIN signal to PXI_CLK10_IN without using its 10 MHz PLL by completing steps a through d.



Note Use the data in the C function call reference as inputs to your LabVIEW VI where applicable.

- a. Call niSync Initialize VI to set up a handle for the device.

LabVIEW Block Diagram	NI-SYNC C Function Call
	<p>Call <code>niSync_init</code> with the following parameters:</p> <p>resourceName: Dev1 idQuery: NULL resetDevice: VI_TRUE vi: *SessionHandle</p>

- b. Set a writable NI-Sync property node to pass FALSE to the **Use PLL?** attribute.

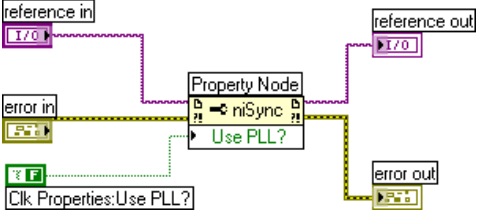
LabVIEW Block Diagram	NI-SYNC C Function Call
	<p>Call <code>niSync_SetAttributeViBoolean</code> with the following parameters:</p> <p>vi: "<SessionHandle>" terminalName: "" attributeID: <code>NISYNC_ATTR_CLKIN_USE_PLL</code> attributeValue: <code>VI_FALSE</code></p>

- c. Call `niSync Connect Clock Terminals VI` to connect `CLKIN` to `PXI_CLK10_IN`.

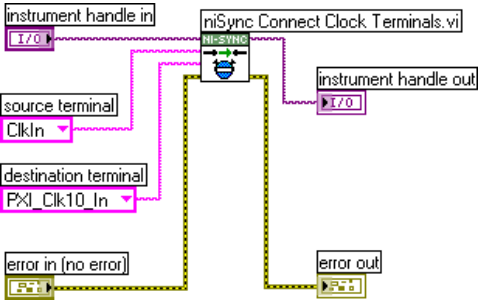
LabVIEW Block Diagram	NI-SYNC C Function Call
	<p>Call <code>niSync_ConnectClkTerminals</code> with the following parameters:</p> <p>vi: "<SessionHandle>" sourceTerminal: <code>NISYNC_VAL_CLKIN</code> destinationTerminal: <code>NISYNC_VAL_CLK10</code></p>

- d. Call `niSync Close VI` to close the handle.

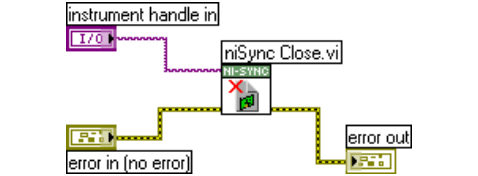
LabVIEW Block Diagram	NI-SYNC C Function Call
	<p>Call <code>niSync_close</code> with the following parameter:</p> <p>vi: "<SessionHandle>"</p>

Measuring the Frequency

Complete the following procedure to measure the frequency of the onboard clock source.

1. Complete steps a to c to measure the oscillator frequency. To obtain an accurate measurement for calibration, the measurement duration must be made sufficiently long. Refer to Table 1 for the measurement duration to use.

Table 1. Measurement Duration

Device	Measure Accuracy	Required Measurement Duration
NI PXIe-6674T	0.5 ppb	20 seconds

- a. Call niSync Initialize VI to set up a handle for the device.

LabVIEW Block Diagram	NI-SYNC C Function Call
	<p>Call <code>niSync_init</code> with the following parameters:</p> <p>resourceName: Dev1 idQuery: NULL resetDevice: VI_FALSE vi: *SessionHandle</p>

- b. Call niSync Measure Frequency VI to measure the frequency of the oscillator.

LabVIEW Block Diagram	NI-SYNC C Function Call
	<p>Call <code>niSync_MeasureFrequency</code> with the following parameters:</p> <p>vi: "<SessionHandle>" sourceTerminal: NISYNC_VAL_OSCILLATOR duration: 20 actualDuration: *actualDuration measuredFrequency: *measuredFrequency error: *error</p>

- c. Call niSync Close VI to close the session handle.

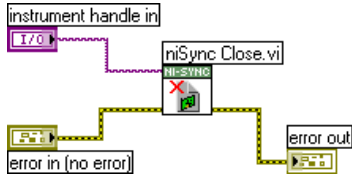
LabVIEW Block Diagram	NI-SYNC C Function Call
 <p>The diagram shows a LabVIEW block diagram. On the left, there is an 'instrument handle in' block with an I/O icon. A red dashed line connects it to the 'niSync Close.vi' block, which has an NI-SYNC icon. Below this, there is an 'error in (no error)' block with an error icon. A yellow dashed line connects the 'niSync Close.vi' block to an 'error out' block with an error icon.</p>	<p>Call <code>niSync_close</code> with the following parameter:</p> <p>vi: "<<SessionHandle>"</p>

- 2. Compare the measured frequency to the device specifications.

To determine if the device under test meets its specifications, you must compare the measured frequency obtained in step 1 of *Measuring the Frequency* with the specified accuracy. Table 2 shows the frequency range that is acceptable according to the published specifications for the NI PXIe-6674T.

Table 2. One Year Test Limits

Device	Specified Accuracy Within 1 Year of Calibration	Acceptable Frequency Range—As Found	
		Low Limit	High Limit
NI PXIe-6674T	± 80 ppb	9,999,999.20 Hz	10,000,000.80 Hz

Table 3. Adjustment Target Frequency Ranges

Device	Calibration Measurement Accuracy	Calibration Measurement Target Frequency Range—As Left	
		Low Limit	High Limit
NI PXIe-6674T	0.5 ppb	9,999,999.995 Hz	10,000,000.005 Hz

If the measured value is within the low-limit and high-limit range listed under the *Calibration Measurement Target Frequency Range* in Table 3, the board is considered to be calibrated and no adjustment is needed.

Adjustment



Note A binary search algorithm may be used to find the optimal oscillator control voltage. The NI PXIe-6674T uses a 16-bit digital-to-analog converter (DAC) to create the oscillator control voltage, therefore at most 16 iterations of adjusting and measuring would be needed to calibrate the 10 MHz oscillator.

If the accuracy of the 10 MHz oscillator is outside the specified range for the product, the device is out of calibration. A programmable voltage controls the oscillator frequency. By varying this voltage and precisely measuring the frequency, you can find a voltage that gives a frequency as close as possible to 10 MHz.

1. Complete steps a to c to set the oscillator control voltage. The range of acceptable voltage values is 0.0 V to 4.095 V with frequency increasing as voltage increases. Use a control voltage of 2.0475 V, which is in the middle of the valid range, as a starting point.
 - a. Call niSync Initialize VI to set up a handle for the device.

LabVIEW Block Diagram	NI-SYNC C Function Call
	<p>Call <code>niSync_init</code> with the following parameters:</p> <p>resourceName: Dev1 idQuery: NULL resetDevice: VI_FALSE vi: *SessionHandle</p>

- b. Set a writable NI-Sync property node to pass the constant **2.0475** to the **Oscillator Voltage** attribute.

LabVIEW Block Diagram	NI-SYNC C Function Call
	<p>Call <code>niSync_SetAttributeViBoolean</code> with the following parameters:</p> <p>vi: "<SessionHandle>" terminalName: "" attributeID: NISYNC_ATTR_OSCILLATOR_VOLTAGE attributeValue: 2.0475</p>

- c. Call niSync Close VI to close the session handle.

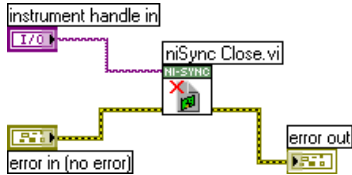
LabVIEW Block Diagram	NI-SYNC C Function Call
 <p>The diagram shows a LabVIEW block diagram for the 'niSync Close.vi' function. It features an 'instrument handle in' control with a 'I7.0' value, an 'error in (no error)' control, and an 'error out' indicator. The 'niSync Close.vi' block is connected to these inputs and outputs.</p>	<p>Call <code>niSync_close</code> with the following parameter:</p> <p>vi: "<SessionHandle>"</p>

Proceed with the following steps to find the correct oscillator control voltage.

2. After setting the control voltage, measure the frequency again with the NI-Sync Measure Frequency VI, as shown in step 1 of the [Measuring the Frequency](#) section.
3. Compare the measured frequency to the device specifications.
4. If the measured frequency is still outside of the specified limit, repeat steps 1 to 3 of the [Adjustment](#) section until the measured value falls within the acceptable frequency range for your module, as shown in Table 3, [Adjustment Target Frequency Ranges](#). Adjust the oscillator control voltage up to increase the frequency and down to decrease the frequency.
5. Commit the calibration values to the Calibration EEPROM using the following procedure.
 - a. Call niSync Initialize External Calibration VI to initialize the process.

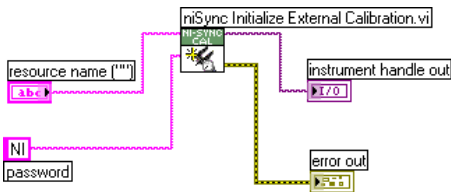

Note NI is the default user password. If you have changed the calibration password, use your user-selected calibration password in place of NI.

LabVIEW Block Diagram	NI-SYNC C Function Call
 <p>The diagram shows a LabVIEW block diagram for the 'niSync Initialize External Calibration.vi' function. It features a 'resource name (""') control with an 'ABC' value, a 'password' control with the value 'NI', and an 'instrument handle out' control with a 'I7.0' value. The 'niSync Initialize External Calibration.vi' block is connected to these inputs and outputs, along with an 'error out' indicator.</p>	<p>Call <code>niSync_InitExtCal</code> with the following parameters:</p> <p>resourceName: "<MAX ID>"</p> <p>password: NI</p> <p>calibrationInstrumentHandle: *SessionHandle</p>

- b. Call niSync Adjust Oscillator Voltage VI to adjust the voltage of the oscillator.

LabVIEW Block Diagram	NI-SYNC C Function Call
	<p>Call <code>niSync_CalAdjustOscillatorVoltage</code> with the following parameters:</p> <p>vi: "<SessionHandle>" newVoltage: <new control voltage> oldVoltage: *oldVoltage</p>

- c. Call niSync Close External Calibration VI to commit the settings and close the session.

LabVIEW Block Diagram	NI-SYNC C Function Call
	<p>Call <code>niSync_CloseExtCal</code> with the following parameter:</p> <p>vi: "<SessionHandle>" action: <code>NISYNC_VAL_EXT_CAL_COMMIT</code></p>

Reverification

After completing the adjustments to the NI PXIe-6674T, it is important that you verify the oscillator frequency operation by repeating the steps listed in the [Verification](#) section. Re-verifying after making the adjustments ensures that the NI PXIe-6674T is operating within its test limits.

Worldwide Support and Services

The NI website is your complete resource for technical support. At ni.com/support you have access to everything from troubleshooting and application development self-help resources to email and phone assistance from NI Application Engineers.

Visit ni.com/services for NI Factory Installation Services, repairs, extended warranty, and other services.

Visit ni.com/register to register your NI product. Product registration facilitates technical support and ensures that you receive important information updates from NI.

A Declaration of Conformity (DoC) is our claim of compliance with the Council of the European Communities using the manufacturer's declaration of conformity. This system affords the user protection for electromagnetic compatibility (EMC) and product safety. You can obtain the DoC for your product by visiting ni.com/certification. If your product supports calibration, you can obtain the calibration certificate for your product at ni.com/calibration.

NI corporate headquarters is located at 11500 North Mopac Expressway, Austin, Texas, 78759-3504. NI also has offices located around the world. For telephone support in the United States, create your service request at ni.com/support or dial 1 866 ASK MYNI (275 6964). For telephone support outside the United States, visit the Worldwide Offices section of ni.com/niglobal to access the branch office websites, which provide up-to-date contact information, support phone numbers, email addresses, and current events.

Refer to the *NI Trademarks and Logo Guidelines* at ni.com/trademarks for more information on NI trademarks. Other product and company names mentioned herein are trademarks or trade names of their respective companies. For patents covering NI products/technology, refer to the appropriate location: **Help»Patents** in your software, the `patents.txt` file on your media, or the *National Instruments Patents Notice* at ni.com/patents. You can find information about end-user license agreements (EULAs) and third-party legal notices in the `readme` file for your NI product. Refer to the *Export Compliance Information* at ni.com/legal/export-compliance for the NI global trade compliance policy and how to obtain relevant HTS codes, ECCNs, and other import/export data. NI MAKES NO EXPRESS OR IMPLIED WARRANTIES AS TO THE ACCURACY OF THE INFORMATION CONTAINED HEREIN AND SHALL NOT BE LIABLE FOR ANY ERRORS. U.S. Government Customers: The data contained in this manual was developed at private expense and is subject to the applicable limited rights and restricted data rights as set forth in FAR 52.227-14, DFAR 252.227-7014, and DFAR 252.227-7015.

© 2010–2016 National Instruments. All rights reserved.