

## COMPREHENSIVE SERVICES

We offer competitive repair and calibration services, as well as easily accessible documentation and free downloadable resources.

## SELL YOUR SURPLUS

We buy new, used, decommissioned, and surplus parts from every NI series. We work out the best solution to suit your individual needs.

 Sell For Cash    Get Credit    Receive a Trade-In Deal

## OBSOLETE NI HARDWARE IN STOCK & READY TO SHIP

We stock **New**, **New Surplus**, **Refurbished**, and **Reconditioned** NI Hardware.



*Bridging the gap between the manufacturer and your legacy test system.*

 1-800-915-6216

 [www.apexwaves.com](http://www.apexwaves.com)

 [sales@apexwaves.com](mailto:sales@apexwaves.com)

*All trademarks, brands, and brand names are the property of their respective owners.*

**Request a Quote**

 **CLICK HERE**

**cDAQ-9178**

# Ferrite Installation Guide

## for NI cDAQ-9178/9174 Cables

This guide describes how to install a snap-on noise-suppression device, called a ferrite, onto your cables to attain a desired level of electromagnetic compatibility (EMC). To ensure that National Instruments devices meet all EMC standards applicable to your country, you need to install a noise-suppression device to the external USB, power, and optional BNC trigger cables.



**Note** Power off the NI cDAQ-9178/9174 chassis while installing the ferrites onto your external cables.

### USB and Power Cables

Using the provided ferrite, wrap the USB and power cables around one side of the ferrite so that they pass through the ferrite twice, as shown in Figure 1.

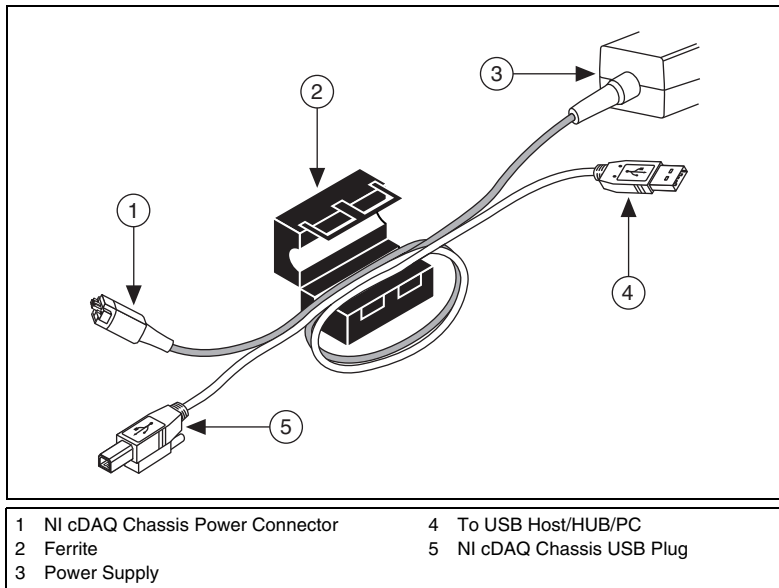

**Figure 1.** Ferrite Open Over Looped Cables

Install the ferrite as close as possible to where the cables plug into the NI cDAQ-9178/9174 chassis. Placing the ferrite elsewhere on the cable noticeably reduces its effectiveness. Snap the ferrite closed to secure it in place, as shown in Figure 2.

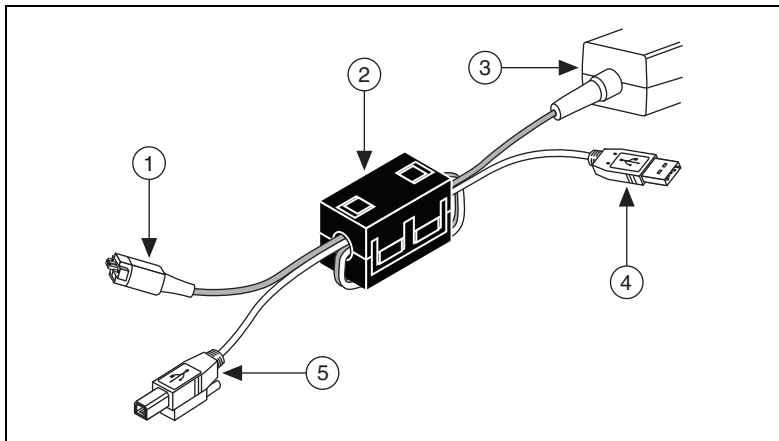

- 1 NI cDAQ Chassis Power Connector
- 2 Ferrite
- 3 Power Supply

- 4 To USB Host/HUB/PC
- 5 NI cDAQ Chassis USB Plug

**Figure 2.** Ferrite Closed Over Looped Cables

## BNC Trigger Cables (NI cDAQ-9178 Only)

If you are using the NI cDAQ-9178 chassis PFI trigger lines, you should install a ferrite with an impedance of 275  $\Omega$  at 100 MHz on each BNC trigger cable used. This type of ferrite is available from National Instruments (part number 781233-01). Install the ferrite as close as possible to where the cable plugs into the NI cDAQ-9178 chassis. Placing the ferrite elsewhere on the cable

noticeably reduces its effectiveness. To install the ferrite, snap it closed around your BNC trigger cable. as shown in Figure 3.

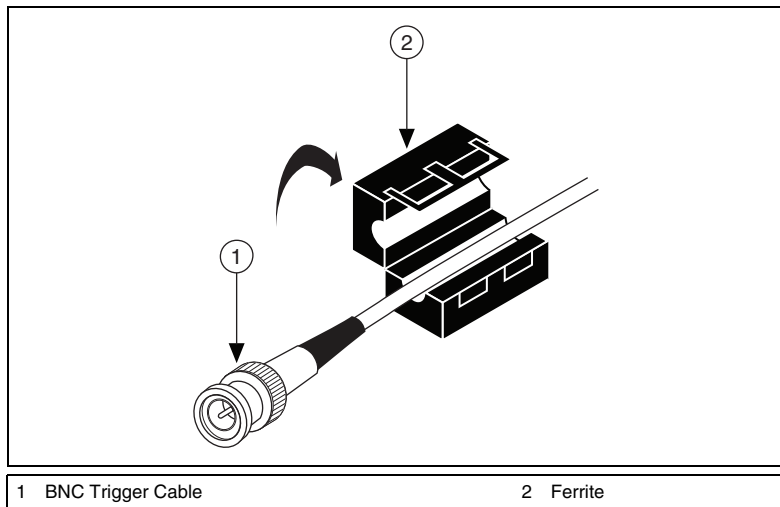

**Figure 3.** Ferrite Open Over BNC Trigger Cable

National Instruments, NI, ni.com, and LabVIEW are trademarks of National Instruments Corporation. Refer to the *Terms of Use* section on [ni.com/legal](http://ni.com/legal) for more information about National Instruments trademarks. Other product and company names mentioned herein are trademarks or trade names of their respective companies. For patents covering National Instruments products/technology, refer to the appropriate location: **Help>Patents** in your software, the `patents.txt` file on your media, or the *National Instruments Patent Notice* at [ni.com/patents](http://ni.com/patents).

© 2009 National Instruments Corporation. All rights reserved.