

COMPREHENSIVE SERVICES

We offer competitive repair and calibration services, as well as easily accessible documentation and free downloadable resources.

SELL YOUR SURPLUS

We buy new, used, decommissioned, and surplus parts from every NI series. We work out the best solution to suit your individual needs.

 Sell For Cash  Get Credit  Receive a Trade-In Deal

OBSOLETE NI HARDWARE IN STOCK & READY TO SHIP

We stock **New**, **New Surplus**, **Refurbished**, and **Reconditioned** NI Hardware.



Bridging the gap between the manufacturer and your legacy test system.

 1-800-915-6216

 www.apexwaves.com

 sales@apexwaves.com

All trademarks, brands, and brand names are the property of their respective owners.

Request a Quote

 **CLICK HERE**

cRIO-9075

NI cRIO-9075/9076

Reconfigurable Embedded Chassis with Integrated Intelligent Real-Time Controller for CompactRIO

Figure 1. CompactRIO cRIO-9075/9076

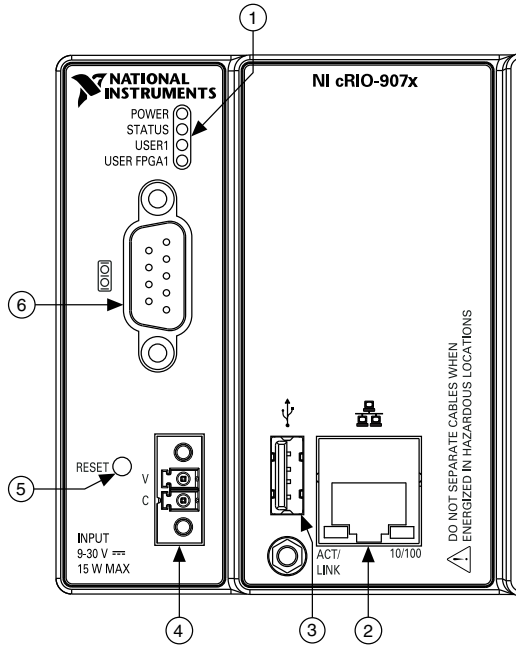

- | | |
|------------------------------|-----------------------|
| 1. LEDs | 4. Power Connector |
| 2. RJ-45 Ethernet Port | 5. Reset Button |
| 3. USB Port (cRIO-9076 Only) | 6. RS-232 Serial Port |

This document describes how to connect the cRIO-9075/9076 to a network and how to use the features of the cRIO-9075/9076.

Safety Guidelines

Operate the cRIO-9075/9076 only as described in this document.



Caution Do not operate the cRIO-9075/9076 in a manner not specified in this document. Product misuse can result in a hazard. You can compromise the safety protection built into the product if the product is damaged in any way. If the product is damaged, return it to NI for repair.

Safety Guidelines for Hazardous Locations

The cRIO-9075/9076 is suitable for use in Class I, Division 2, Groups A, B, C, D, T4 hazardous locations; Class I, Zone 2, AEx nA IIC T4 and Ex nA IIC T4 hazardous locations; and nonhazardous locations only. Follow these guidelines if you are installing the cRIO-9075/9076 in a potentially explosive environment. Not following these guidelines may result in serious injury or death.



Caution Do not disconnect the power supply wires and connectors from the controller unless power has been switched off.



Caution Do not disconnect I/O-side wires or connectors unless power has been switched off or the area is known to be nonhazardous.



Caution Do not remove modules unless power has been switched off or the area is known to be nonhazardous.



Caution Substitution of components may impair suitability for Class I, Division 2.



Caution For Division 2 and Zone 2 applications, install the system in an enclosure rated to at least IP54 as defined by IEC/EN 60079-15.

Special Conditions for Hazardous Locations Use in Europe and Internationally

The cRIO-9075/9076 has been evaluated as Ex nA IIC T4 Gc equipment under DEMKO Certificate No. 07 ATEX 0626664X and is IECEx UL 14.0089X certified. Each device is marked Ⓢ II 3G and is suitable for use in Zone 2 hazardous locations, in ambient temperatures of $-20\text{ }^{\circ}\text{C} \leq T_a \leq 55\text{ }^{\circ}\text{C}$.



Caution You must make sure that transient disturbances do not exceed 140% of the rated voltage.



Caution The system shall only be used in an area of not more than Pollution Degree 2, as defined in IEC 60664-1.



Caution The system shall be mounted in an ATEX/IECEx-certified enclosure with a minimum ingress protection rating of at least IP54 as defined in IEC/EN 60079-15.



Caution The enclosure must have a door or cover accessible only by the use of a tool.

Electromagnetic Compatibility Guidelines

This product was tested and complies with the regulatory requirements and limits for electromagnetic compatibility (EMC) stated in the product specifications. These requirements and limits provide reasonable protection against harmful interference when the product is operated in the intended operational electromagnetic environment.

This product is intended for use in industrial locations. However, harmful interference may occur in some installations, when the product is connected to a peripheral device or test object, or if the product is used in residential or commercial areas. To minimize interference with radio and television reception and prevent unacceptable performance degradation, install and use this product in strict accordance with the instructions in the product documentation.

Furthermore, any changes or modifications to the product not expressly approved by National Instruments could void your authority to operate it under your local regulatory rules.

Special Conditions for Marine Applications

Some products are Lloyd's Register (LR) Type Approved for marine (shipboard) applications. To verify Lloyd's Register certification for a product, visit ni.com/certification and search for the LR certificate, or look for the Lloyd's Register mark on the product.



Caution In order to meet the EMC requirements for marine applications, install the product in a shielded enclosure with shielded and/or filtered power and input/output ports. In addition, take precautions when designing, selecting, and installing measurement probes and cables to ensure that the desired EMC performance is attained.

What You Need to Install CompactRIO Reconfigurable Embedded Hardware

- CompactRIO reconfigurable embedded chassis with integrated intelligent real-time controller
- C Series I/O modules
- DIN rail mount kit (for DIN rail mounting only)
- Two M4 or number 8 flathead screws (for mounting the chassis without one of the listed mounting kits)
- A number 2 Phillips screwdriver
- Power supply
- Ethernet cable



Note Visit ni.com/info and enter the Info Code `rdsoftwareversion` to determine which software you need to use the cRIO-9075/9076.

Mounting the CompactRIO Reconfigurable Embedded Chassis

You can mount the chassis in any orientation on a 35 mm DIN rail or on a panel. Use the DIN rail mounting method if you already have a DIN rail configuration or if you need to be able to quickly remove the CompactRIO chassis. Use the panel mount method for high shock and vibration applications.



Note For information about how different mounting configurations can cause temperature derating, go to ni.com/info and enter the Info Code `criomounting`.



Note For information about typical accuracy specifications for modules, go to ni.com/info and enter the Info Code `criotypical`.



Caution Your installation must meet the following requirements for space and cabling clearance:

- Allow 25.4 mm (1 in.) on the top and the bottom of the chassis for air circulation.
- Allow 50.8 mm (2 in.) in front of modules for cabling clearance for common connectors, such as the 10-terminal, detachable screw terminal connector.

Figure 2. cRIO-9075/9076 Bottom View with Dimensions

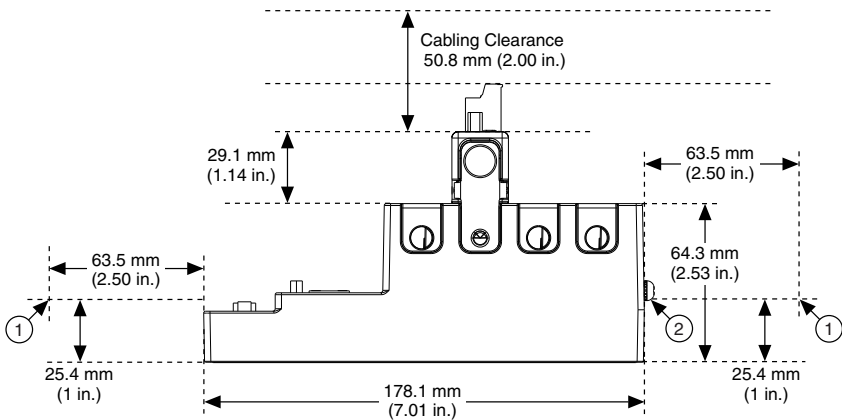

1. Measure ambient temperature here.
2. Chassis Grounding Screw



Note Go to ni.com/info and enter the Info Code `rdcrioconn` to find the minimum cabling clearance for C Series modules with other connector types.

Figure 3. cRIO-9075/9076 Front View with Dimensions

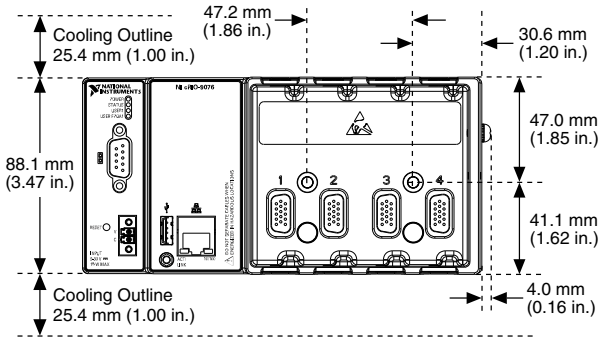
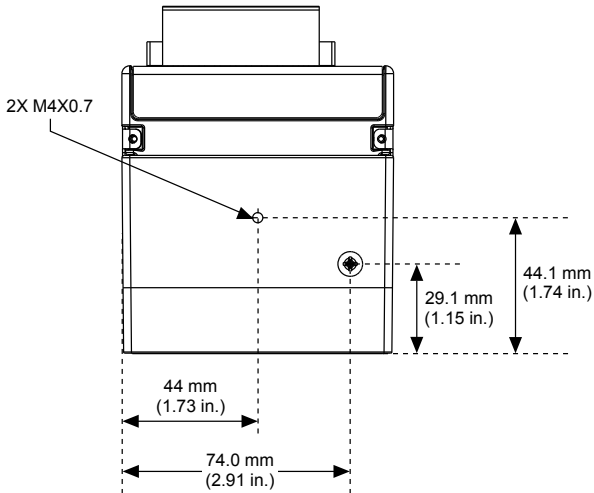

Figure 4. cRIO-9075/9076 Side View with Dimensions



Note For two-dimensional drawings and three-dimensional models, visit ni.com/dimensions and search by module number.

The following sections contain instructions for the mounting methods. Before using any of these mounting methods, record the serial number from the back of the chassis. You will be unable to read the serial number after you have mounted the chassis.



Caution Make sure that no I/O modules are in the chassis before mounting it.

Mounting the Chassis on a Panel

Panel or wall mounting is the best method for applications that are subject to high shock and vibration. You can use the NI 9904 panel mount kit to mount the cRIO-9075/9076 on a flat surface. Complete the following steps.

1. Fasten the chassis to the panel mount kit using a number 2 Phillips screwdriver and two M4 × 25 screws. NI provides these screws with the panel mount kit. You must use these screws because they are the correct depth and thread for the panel. Tighten the screws to a maximum torque of 1.3 N · m (11.5 lb · in.).

Figure 5. Installing the Panel Mount Accessory on the cRIO-9075/9076

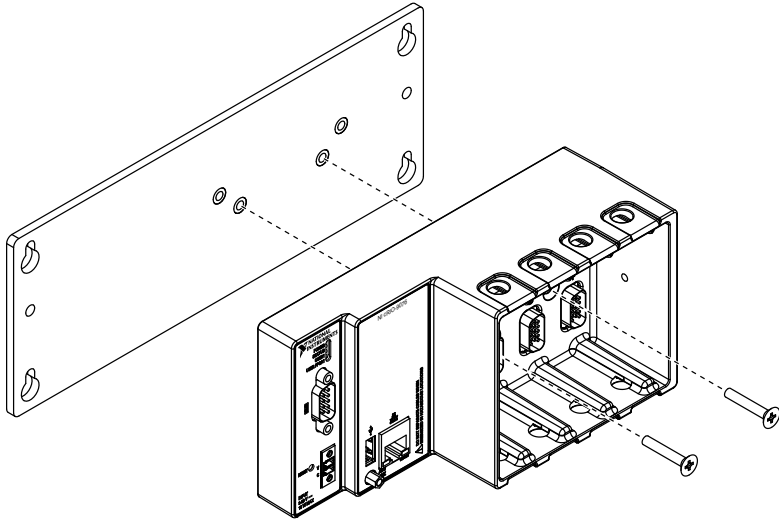
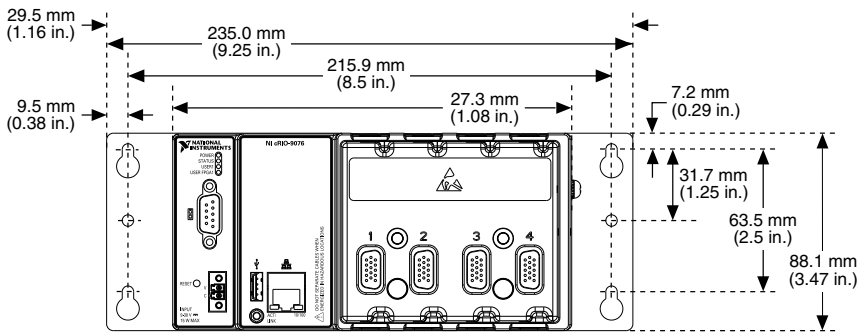

Figure 6. Dimensions of cRIO-9075/9076 with Panel Mount Accessory Installed



2. Fasten the NI 9904 panel to the wall using the screwdriver and screws that are appropriate for the wall surface. The maximum screw size is M4 or number 8.



Caution Make sure that no I/O modules are in the chassis before removing it from the panel.

Mounting the Chassis Directly on a Flat Surface Using the Mounting Holes

Panel or wall mounting is the best method for applications that are subject to high shock and vibration. If you do not have the NI 9904 panel mount kit and do not require the portability that the NI 9904 affords, you can mount the chassis directly on a flat surface using the mounting holes. Complete the following steps.

1. Align the chassis on the surface.
2. Fasten the chassis to the surface using M4 or number 8 flathead screws. NI does not provide these screws with the chassis.

Figure 7. Mounting the Chassis Directly on a Flat Surface

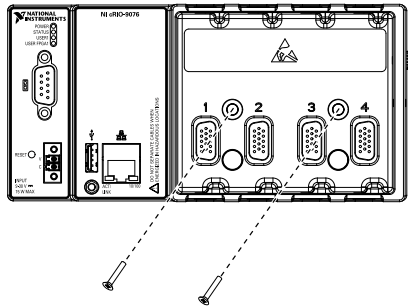

Mounting the Chassis on a DIN Rail

You can order the NI 9912 DIN rail mount kit if you want to mount the chassis on a DIN rail. You need one clip for mounting the chassis on a standard 35 mm DIN rail. Complete the following steps to mount the chassis on a DIN rail.

1. Fasten the DIN rail clip to the chassis using a number 2 Phillips screwdriver and two M4 × 25 screws. NI provides these screws with the DIN rail mount kit. Tighten the screws to a maximum torque of 1.3 N · m (11.5 lb · in.).

Figure 8. Installing the DIN Rail Clip on the cRIO-9075/9076

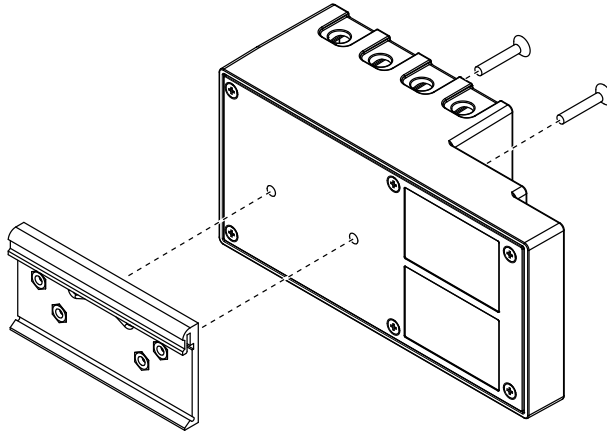

2. Insert one edge of the DIN rail into the deeper opening of the DIN rail clip.

Figure 9. One Edge of the DIN Rail Inserted in a Clip

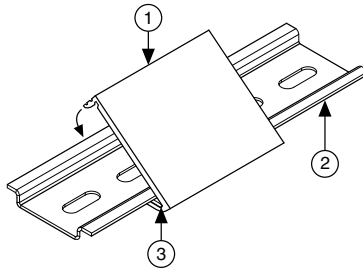

1. DIN Rail Clip
2. DIN Rail
3. DIN Rail Spring

3. Press down firmly on the chassis to compress the spring until the clip locks in place on the DIN rail.



Caution Make sure that no I/O modules are in the chassis before removing it from the DIN rail.

Mounting the Chassis on a Desktop Using the NI 9901 Desktop Mounting Kit

You can use the NI 9901 desktop mounting kit to mount the chassis on a desktop. You must install the adapter bracket using two M3 × 20 screws. The adapter bracket and the screws are included in the kit. Refer to the NI 9901 documentation for information about mounting the chassis on a desktop.

Installing C Series I/O Modules in the Chassis

The following figure shows the mechanical dimensions of C Series I/O modules.

Figure 10. C Series I/O Module, Front and Side View with Dimensions

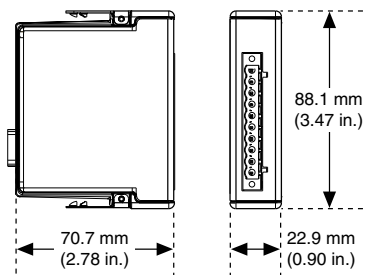

Complete the following steps to install a C Series I/O module in the chassis.

1. Make sure that no I/O-side power is connected to the I/O module. If the system is in a nonhazardous location, the chassis power can be on when you install I/O modules.
2. Align the I/O module with an I/O module slot in the chassis. The module slots are labeled 1 to 4, left to right.

Figure 11. Installing an I/O Module in the Chassis

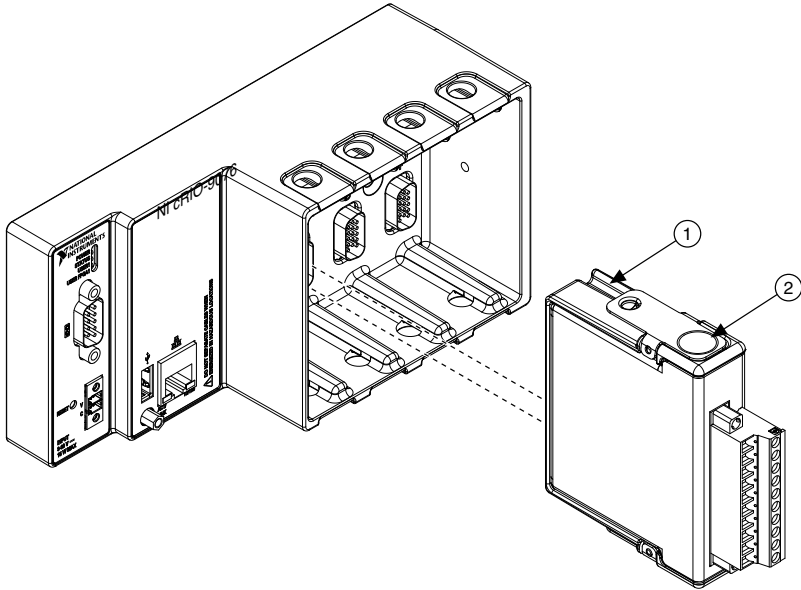

1. Insertion Groove
2. Latch

3. Squeeze the latches and insert the I/O module into the module slot.
4. Press firmly on the connector side of the I/O module until the latches lock the I/O module into place.
5. Repeat these steps to install additional I/O modules.

Removing I/O Modules from the Chassis

Complete the following steps to remove a C Series I/O module from the chassis.

1. Make sure that no I/O-side power is connected to the I/O module. If the system is in a nonhazardous location, the chassis power can be on when you remove I/O modules.
2. Squeeze the latches on both sides of the module and pull the module out of the chassis.

Connecting the Chassis to Earth Ground

You must connect the chassis grounding screw to earth ground. Complete the following steps to connect to earth ground.

1. Attach a ring lug to a 1.6 mm² (14 AWG) or larger wire.
2. Remove the grounding screw from the grounding terminal on the right side of the chassis.
3. Attach the ring lug to the grounding terminal.
4. Tighten the grounding screw to 0.5 N · m (4.4 lb · in.) of torque.

5. Attach the other end of the wire to the grounding electrode system of your facility using a method appropriate for the application.



Caution If you use shielded cabling to connect to a C Series I/O module with a plastic connector, you must attach the cable shield to the chassis grounding terminal using 1.3 mm² (16 AWG) or larger wire. Attach a ring lug to the wire and attach the wire to the chassis grounding terminal. Solder the other end of the wire to the cable shield. Use shorter wire for better EMC performance.

For more information about ground connections, go to ni.com/info and enter the Info Code `emcground`.

Connecting the Chassis to a Network

Connect the chassis to an Ethernet network using the RJ-45 Ethernet port on the controller front panel. Use a standard Category 5 (CAT-5) or better shielded, twisted-pair Ethernet cable to connect the chassis to an Ethernet hub, or use an Ethernet crossover cable to connect the chassis directly to a computer.



Caution To prevent data loss and to maintain the integrity of your Ethernet installation, do not use a cable longer than 100 m.

The first time you power up the chassis, it attempts to initiate a DHCP network connection. If the chassis is unable to initiate a DHCP connection, it connects to the network with a link-local IP address with the form `169.254.x.x`. After powerup, you must install software on the chassis and configure the network settings in NI Measurement & Automation Explorer (MAX).



Note Installing software may change the network behavior of the chassis. For information about network behavior by installed software version, go to ni.com/info and enter the Info Code `ipconfigcrio`.

Wiring Power to the Chassis

The cRIO-9075/9076 requires an external power supply that meets the specifications in the [Power Requirements](#) section. The cRIO-9075/9076 filters and regulates the supplied power and provides power for all of the I/O modules. The cRIO-9075/9076 has one layer of reverse-voltage protection. Complete the following steps to connect a power supply to the chassis.

1. Ensure that the power supply is turned off.



Caution Do not install or remove the power connector from the front panel of the cRIO-9075/9076 while power is applied.

2. Connect the positive lead of the power supply to the V terminal of the power connector shipped with the cRIO-9075/9076, and tighten the terminal screw. The following figure shows the terminal screws, which secure the wires in the screw terminals, and the connector screws, which secure the power connector on the front panel.

Figure 12. Power Connector

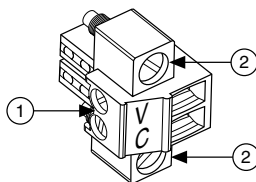

1. Terminal Screws
 2. Connector Screws
3. Connect the negative lead of the power supply to the C terminal of the power connector and tighten the terminal screw.
 4. Install the power connector on the front panel of the cRIO-9075/9076 and tighten the connector screws.
 5. Turn on the power supply.

Powering On the cRIO-9075/9076

When you apply power to the cRIO-9075/9076, the controller runs a power-on self test (POST). During the POST, the Power and Status LEDs turn on. The Status LED turns off, indicating that the POST is complete. If the LEDs do not behave in this way when the system powers on, refer to the [Understanding LED Indications](#) section.

You can configure the cRIO-9075/9076 to launch an embedded stand-alone LabVIEW RT application each time you boot the controller. Refer to the [LabVIEW Help](#) for more information.

Restarting the cRIO-9075/9076 Using the Reset Button

Pressing the Reset button restarts the controller. The FPGA continues to run unless you have selected the **Autoload VI on device reboot** chassis reset option. Refer to the [Chassis Reset Options](#) section for more information.

To restart the cRIO-9075/9076 in safe mode, press and hold the Reset button for 5 s, then release it. The Status LED lights solid yellow, indicating that the cRIO-9075/9076 is in safe mode. Refer to the MAX help for information about safe mode.

Controller Startup Options

You can configure the following controller startup options in MAX:

- Safe Mode
- Console Out
- IP Reset
- No App
- No FPGA App

To turn these startup options on or off, select the controller under **Remote Systems** in the MAX configuration tree, then select the **Controller Settings** tab. Refer to the MAX help for information about the startup options and how to configure the controller.

Chassis Reset Options

The following table lists the reset options available on CompactRIO systems such as the cRIO-9075/9076. These options determine how the chassis behaves when the controller is reset in various conditions. Use the RIO Device Setup utility to select reset options. Access the RIO Device Setup utility by selecting **Start»All Programs»National Instruments»NI-RIO»RIO Device Setup**.

Table 1. CompactRIO Reset Options

Chassis Reset Option	Behavior
Do not autoloading VI	Does not load the FPGA bit stream from flash memory.
Autoload VI on device powerup	Loads the FPGA bit stream from flash memory to the FPGA when the controller powers on.
Autoload VI on device reboot	Loads the FPGA bit stream from flash memory to the FPGA when you reboot the controller either with or without cycling power.

Connecting Serial Devices to the cRIO-9075/9076

The cRIO-9075/9076 has an RS-232 serial port to which you can connect devices such as displays or input devices. Use the Serial VIs to read from and write to the serial port from a LabVIEW RT application. For more information about the Serial VIs, refer to the *LabVIEW Help*.

Figure 13. Controller Serial Port

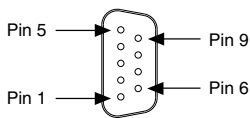

Table 2. DB-9 Pin Descriptions

Pin	Signal
1	DCD
2	RXD
3	TXD

Table 2. DB-9 Pin Descriptions (Continued)

Pin	Signal
4	DTR
5	GND
6	DSR
7	RTS
8	CTS
9	RI

Understanding LED Indications

Figure 14. cRIO-9075/9076 LEDs

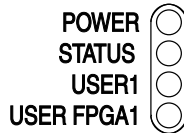

POWER LED

The POWER LED is lit while the cRIO-9075/9076 is powered on. This LED indicates that the power supply connected to the chassis is adequate.

STATUS LED

The STATUS LED is off during normal operation. The cRIO-9075/9076 indicates specific error conditions by flashing the STATUS LED a certain number of times every few seconds, as shown in the following table

Number of Flashes Every Few Seconds	Indication
2	The chassis has detected an error in its software. This usually occurs when an attempt to upgrade the software is interrupted. Reinstall software on the chassis. Refer to the <i>Measurement & Automation Explorer Help</i> for information about installing software on the chassis.
3	The chassis is in safe mode. Refer to the <i>Measurement & Automation Explorer Help</i> for information about safe mode.

Number of Flashes Every Few Seconds	Indication
4	The software has crashed twice without rebooting or cycling power between crashes. This usually occurs when the chassis runs out of memory. Review your RT VI and check the memory usage. Modify the VI as necessary to solve the memory usage issue.
Continuously flashing or solid	The chassis has detected an unrecoverable error. Contact National Instruments.

USER1 LED

You can define the USER1 LED to meet the needs of your application. To define the LED, use the RT LEDs VI in LabVIEW. For more information about the RT LEDs VI, refer to the *LabVIEW Help*.

FPGA LED

You can use the FPGA LED to help debug your application or easily retrieve application status. Use the LabVIEW FPGA Module and NI-RIO software to define the FPGA LED to meet the needs of your application. Refer to *LabVIEW Help* for information about programming this LED.

Using the System Clock to Provide Data Timestamps

At startup, the system clock resets to January 1, 1970, 12:00 a.m. (midnight). For information about synchronizing the system clock with an SNTP time server on the network at startup, go to ni.com/info and enter the Info Code `criosntp`.

Troubleshooting Network Communication

If the cRIO-9075/9076 cannot communicate with the network, you can perform the following troubleshooting steps.

1. Hold the Reset button down for 5 s, then release it. The Status LED turns on, then starts blinking three times every few seconds. The chassis is now in safe mode with output from the serial port enabled. You can use a serial port terminal to read the IP address of the controller. If you want the controller to attempt a new DHCP connection, proceed to step 2.
2. Hold the Reset button down for 5 s, then release it. The Status LED repeats the same behavior. The cRIO-9075/9076 attempts to establish a new DHCP connection. If it fails, it assigns itself a link-local IP address. If the DHCP connection is successful and appropriate for your application, skip to step 4.
3. Configure the IP and other network settings in MAX.

4. Press and release the Reset button to reboot the chassis.

Where to Go from Here

Now that you have set up the cRIO-9075/9076 and configured it on your network, you can start using it in your applications. The following figure shows the main components of the CompactRIO documentation that you may find helpful as you program and use the cRIO-9075/9076.

Figure 15. CompactRIO Documentation

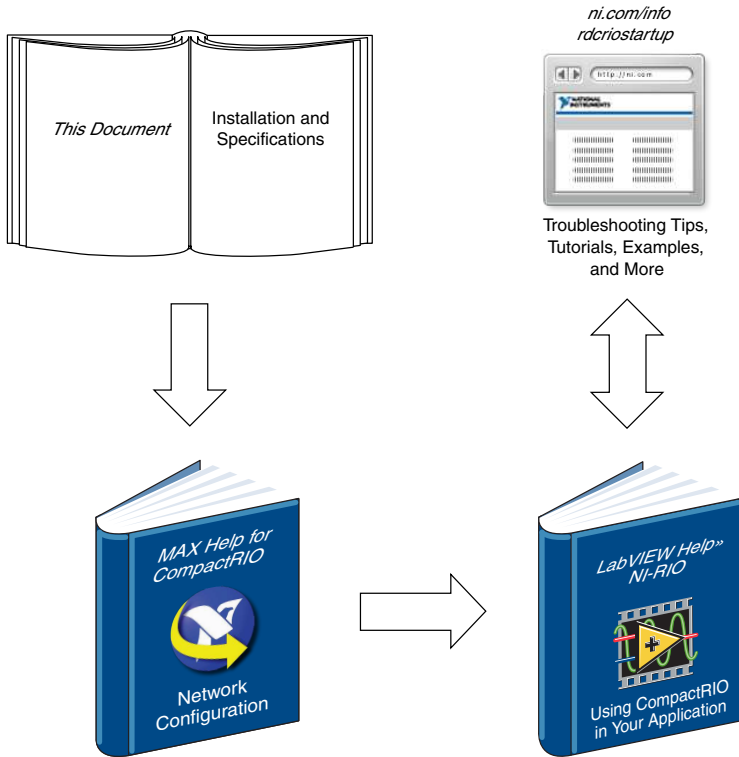

cRIO-9075/9076 Specifications

The following specifications are typical for the range -20 °C to 55 °C unless otherwise noted.



Caution Do not operate the cRIO-9075/9076 in a manner not specified in this document. Product misuse can result in a hazard. You can compromise the safety protection built into the product if the product is damaged in any way. If the product is damaged, return it to NI for repair.

Network

Network interface	10Base-T and 100Base-TX Ethernet
Compatibility	IEEE 802.3
Communication rates	10 Mbps, 100 Mbps, auto-negotiated
Maximum cabling distance	100 m/segment

RS-232 Serial Port

Maximum baud rate	230,400 bps
Data bits	5, 6, 7, 8
Stop bits	1, 2
Parity	Odd, Even, Mark, Space
Flow control	RTS/CTS, XON/XOFF, DTR/DSR

Memory

cRIO-9075

Nonvolatile	256 MB minimum
DRAM	128 MB

cRIO-9076

Nonvolatile	512 MB minimum
DRAM	256 MB

For information about the life span of the nonvolatile memory and about best practices for using nonvolatile memory, go to ni.com/info and enter the Info Code `SSDBP`.

Reconfigurable FPGA

cRIO-9075

FPGA type	Xilinx Spartan-6 LX 25
Number of flip-flops	30,064
Number of 6-input LUTs	15,032
Number of DSP48s	38
Available block RAM	936 kbits
Number of DMA channels	5

cRIO-9076

FPGA type	Xilinx Spartan-6 LX 45
Number of flip-flops	54,576
Number of 6-input LUTs	27,288
Number of DSP48s	58
Available block RAM	2,088 kbits
Number of DMA channels	5

For information about the life span of the nonvolatile memory and about best practices for using nonvolatile memory, go to <http://www.ni.com/info> and enter the Info Code SSDBP.

Power Requirements



Caution You must use a UL Listed ITE power supply marked **LPS** with the cRIO-9075/9076.

Recommended power supply	24 W, 24 VDC
Power consumption	15 W maximum
Power supply input range	9 V to 30 V

Physical Characteristics

If you need to clean the module, wipe it with a dry towel.



Tip For two-dimensional drawings and three-dimensional models of the C Series module and connectors, visit ni.com/dimensions and search by module number.

Screw-terminal wiring

Gauge	0.13 mm ² to 2.1 mm ² (26 AWG to 14 AWG) copper conductor wire
Wire strip length	6 mm (0.24 in.) of insulation stripped from the end
Temperature rating	85 °C
Torque for screw terminals	0.20 N · m to 0.25 N · m (1.8 lb · in. to 2.2 lb · in.)
Wires per screw terminal	One wire per screw terminal
Ferrules	0.25 mm ² to 1.5 mm ²

Connector securement

Securement type	Screw flanges provided
Torque for screw flanges	0.3 N · m to 0.4 N · m (2.7 lb · in. to 3.5 lb · in.)
Dimensions (unloaded)	178.1 mm × 87.3 mm × 64.3 mm (7.0 in. × 3.4 in. × 2.5 in.)
Weight	643 g (22.7oz)

Safety Voltages

Connect only voltages that are within the following limits:

V terminal to C terminal	30 V maximum, Measurement Category I
--------------------------	--------------------------------------

Measurement Category I is for measurements performed on circuits not directly connected to the electrical distribution system referred to as *MAINS* voltage. MAINS is a hazardous live electrical supply system that powers equipment. This category is for measurements of voltages from specially protected secondary circuits. Such voltage measurements include signal levels, special equipment, limited-energy parts of equipment, circuits powered by regulated low-voltage sources, and electronics.



Caution Do not connect the cRIO-9075/9076 to signals or use for measurements within Measurement Categories II, III, or IV.



Note Measurement Categories CAT I and CAT O are equivalent. These test and measurement circuits are not intended for direct connection to the MAINS building installations of Measurement Categories CAT II, CAT III, or CAT IV.

Hazardous Locations

U.S. (UL)	Class I, Division 2, Groups A, B, C, D, T4; Class I, Zone 2, AEx nA IIC T4
Canada (C-UL)	Class I, Division 2, Groups A, B, C, D, T4; Class I, Zone 2, Ex nA IIC T4
Europe (ATEX) and International (IECEX)	Ex nA IIC T4 Gc

Safety and Hazardous Locations Standards

This product is designed to meet the requirements of the following electrical equipment safety standards for measurement, control, and laboratory use:

- IEC 61010-1, EN 61010-1
- UL 61010-1, CSA 61010-1
- EN 60079-0:2012, EN 60079-15:2010
- IEC 60079-0: Ed 6, IEC 60079-15; Ed 4

- UL 60079-0; Ed 5, UL 60079-15; Ed 3
- CSA 60079-0:2011, CSA 60079-15:2012



Note For UL and other safety certifications, refer to the product label or the [Online Product Certification](#) section.

Electromagnetic Compatibility

This product meets the requirements of the following EMC standards for electrical equipment for measurement, control, and laboratory use:

- EN 61326 (IEC 61326): Class A emissions; Industrial immunity
- EN 55011 (CISPR 11): Group 1, Class A emissions
- AS/NZS CISPR 11: Group 1, Class A emissions
- FCC 47 CFR Part 15B: Class A emissions
- ICES-001: Class A emissions



Note For EMC declarations and certifications, and additional information, refer to the [Online Product Certification](#) section.



Note For EMC compliance, operate this product according to the documentation.

CE Compliance

This product meets the essential requirements of applicable European Directives, as follows:

- 2014/35/EU; Low-Voltage Directive (safety)
- 2014/30/EU; Electromagnetic Compatibility Directive (EMC)
- 94/9/EC; Potentially Explosive Atmospheres (ATEX)

Online Product Certification

Refer to the product Declaration of Conformity (DoC) for additional regulatory compliance information. To obtain product certifications and the DoC for this product, visit ni.com/certification, search by model number or product line, and click the appropriate link in the Certification column.

Shock and Vibration

To meet these specifications, you must panel mount the system.

Operating vibration

Random (IEC 60068-2-64)	5 g _{rms} , 10 Hz to 500 Hz
Sinusoidal (IEC 60068-2-6)	5 g, 10 Hz to 500 Hz
Operating shock (IEC 60068-2-27)	30 g, 11 ms half sine; 50 g, 3 ms half sine; 18 shocks at 6 orientations

Environmental

Refer to the manual for the chassis you are using for more information about meeting these specifications.

Operating temperature (IEC 60068-2-1, IEC 60068-2-2)	-20 °C to 55 °C
Storage temperature (IEC 60068-2-1, IEC 60068-2-2)	-40 °C to 85 °C
Ingress protection	IP40
Operating humidity (IEC 60068-2-78)	10% RH to 90% RH, noncondensing
Storage humidity (IEC 60068-2-78)	5% RH to 95% RH, noncondensing
Pollution Degree	2
Maximum altitude	2,000 m

Indoor use only.

Environmental Management

NI is committed to designing and manufacturing products in an environmentally responsible manner. NI recognizes that eliminating certain hazardous substances from our products is beneficial to the environment and to NI customers.

For additional environmental information, refer to the *Minimize Our Environmental Impact* web page at ni.com/environment. This page contains the environmental regulations and directives with which NI complies, as well as other environmental information not included in this document.

Waste Electrical and Electronic Equipment (WEEE)



EU Customers At the end of the product life cycle, all NI products must be disposed of according to local laws and regulations. For more information about how to recycle NI products in your region, visit ni.com/environment/weee.

电子信息产品污染控制管理办法（中国 RoHS）



中国客户 National Instruments 符合中国电子信息产品中限制使用某些有害物质指令 (RoHS)。关于 National Instruments 中国 RoHS 合规性信息，请登录 ni.com/environment/rohs_china。(For information about China RoHS compliance, go to ni.com/environment/rohs_china.)

Worldwide Support and Services

The NI website is your complete resource for technical support. At ni.com/support, you have access to everything from troubleshooting and application development self-help resources to email and phone assistance from NI Application Engineers.

Visit ni.com/services for NI Factory Installation Services, repairs, extended warranty, and other services.

Visit ni.com/register to register your NI product. Product registration facilitates technical support and ensures that you receive important information updates from NI.

A Declaration of Conformity (DoC) is our claim of compliance with the Council of the European Communities using the manufacturer's declaration of conformity. This system affords the user protection for electromagnetic compatibility (EMC) and product safety. You can obtain the DoC for your product by visiting ni.com/certification. If your product supports calibration, you can obtain the calibration certificate for your product at ni.com/calibration.

NI corporate headquarters is located at 11500 North Mopac Expressway, Austin, Texas, 78759-3504. NI also has offices located around the world. For telephone support in the United States, create your service request at ni.com/support or dial 1 866 ASK MYNI (275 6964). For telephone support outside the United States, visit the *Worldwide Offices* section of ni.com/niglobal to access the branch office websites, which provide up-to-date contact information, support phone numbers, email addresses, and current events.

Refer to the *NI Trademarks and Logo Guidelines* at ni.com/trademarks for information on NI trademarks. Other product and company names mentioned herein are trademarks or trade names of their respective companies. For patents covering NI products/technology, refer to the appropriate location: **Help»Patents** in your software, the `patents.txt` file on your media, or the *National Instruments Patent Notice* at ni.com/patents. You can find information about end-user license agreements (EULAs) and third-party legal notices in the readme file for your NI product. Refer to the *Export Compliance Information* at ni.com/legal/export-compliance for the NI global trade compliance policy and how to obtain relevant HTS codes, ECCNs, and other import/export data. NI MAKES NO EXPRESS OR IMPLIED WARRANTIES AS TO THE ACCURACY OF THE INFORMATION CONTAINED HEREIN AND SHALL NOT BE LIABLE FOR ANY ERRORS. U.S. Government Customers: The data contained in this manual was developed at private expense and is subject to the applicable limited rights and restricted data rights as set forth in FAR 52.227-14, DFAR 252.227-7014, and DFAR 252.227-7015.

© 2011—2016 National Instruments. All rights reserved.

375650D-01 Mar16