

COMPREHENSIVE SERVICES

We offer competitive repair and calibration services, as well as easily accessible documentation and free downloadable resources.

SELL YOUR SURPLUS

We buy new, used, decommissioned, and surplus parts from every NI series. We work out the best solution to suit your individual needs.

 Sell For Cash  Get Credit  Receive a Trade-In Deal

OBSOLETE NI HARDWARE IN STOCK & READY TO SHIP

We stock **New**, **New Surplus**, **Refurbished**, and **Reconditioned** NI Hardware.



Bridging the gap between the manufacturer and your legacy test system.

 1-800-915-6216

 www.apexwaves.com

 sales@apexwaves.com

All trademarks, brands, and brand names are the property of their respective owners.

Request a Quote

 **CLICK HERE**

NI-9242

GETTING STARTED GUIDE

NI 9242

3 AI/1 Neutral, 250 Vrms L-N/400 Vrms L-L,
24 Bit, 50 kS/s/ch Simultaneous

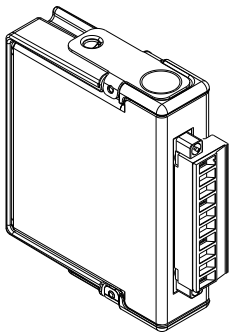

This document explains how to connect to the NI 9242.



Note Before you begin, complete the software and hardware installation procedures in your chassis documentation.



Note The guidelines in this document are specific to the NI 9242. The other components in the system might not meet the same safety ratings. Refer to the documentation for each component in the system to determine the safety and EMC ratings for the entire system.

Safety Guidelines

Operate the NI 9242 only as described in this document.



Caution Do not operate the NI 9242 in a manner not specified in this document. Product misuse can result in a hazard. You can compromise the safety protection built into the product if the product is damaged in any way. If the product is damaged, return it to NI for repair.



Hazardous Voltage This icon denotes a warning advising you to take precautions to avoid electrical shock.

Safety Voltages

Connect only voltages that are within the following limits.

Maximum working voltage, channel-to earth ground

Continuous	250 Vrms, Measurement Category III
------------	---------------------------------------

Division 2 and Zone 2 hazardous locations applications

Channel-to-earth ground	250 Vrms, Measurement Category III
----------------------------	---------------------------------------

Measurement Category III is for measurements performed in the building installation at the distribution level. This category refers to measurements on hard-wired hardware such as hardware in fixed installations, distribution boards, and circuit breakers. Other examples are wiring, including cables, bus bars, junction boxes, switches, socket outlets in the fixed installation, and stationary motors with permanent connections to fixed installations.



Caution Do not connect the NI 9242 to signals or use for measurements within Measurement Category IV.

Safety Guidelines for Hazardous Voltages

If hazardous voltages are connected to the device, take the following precautions. A hazardous voltage is a voltage greater than 42.4 Vpk voltage or 60 VDC to earth ground.



Caution Ensure that hazardous voltage wiring is performed only by qualified personnel adhering to local electrical standards.



Caution Do not mix hazardous voltage circuits and human-accessible circuits on the same module.



Caution Ensure that devices and circuits connected to the module are properly insulated from human contact.



Caution When module terminals are hazardous voltage LIVE (>42.4 Vpk/60 VDC), you must ensure that devices and circuits connected to the module are properly insulated from human contact. You must use the NI 9967 connector backshell kit to ensure that the terminals are not accessible.

Safety Guidelines for Hazardous Locations

The NI 9242 is suitable for use in Class I, Division 2, Groups A, B, C, D, T4 hazardous locations; Class I, Zone 2, AEx nA IIC T4 and Ex nA IIC T4 hazardous locations; and nonhazardous locations only. Follow these guidelines if you are installing the NI 9242 in a potentially explosive environment. Not following these guidelines may result in serious injury or death.



Caution Do not disconnect I/O-side wires or connectors unless power has been switched off or the area is known to be nonhazardous.



Caution Do not remove modules unless power has been switched off or the area is known to be nonhazardous.



Caution Substitution of components may impair suitability for Class I, Division 2.



Caution For Division 2 and Zone 2 applications, install the system in an enclosure rated to at least IP54 as defined by IEC/EN 60079-15.

Special Conditions for Hazardous Locations Use in Europe and Internationally

The NI 9242 has been evaluated as Ex nA IIC T4 Gc equipment under DEMKO Certificate No. 12 ATEX 1202658X and is IECEx UL 14.0089X certified. Each NI 9242 is marked  II 3G and is suitable for use in Zone 2 hazardous locations, in ambient temperatures of $-40\text{ }^{\circ}\text{C} \leq T_a \leq 70\text{ }^{\circ}\text{C}$. If you are using the NI 9242 in Gas Group IIC hazardous locations, you must use the device in an NI chassis that has been evaluated as Ex nC IIC T4, Ex IIC T4, Ex nA IIC T4, or Ex nL IIC T4 equipment.



Caution The system shall only be used in an area of not more than Pollution Degree 2, as defined in IEC 60664-1.



Caution The system shall be mounted in an ATEX/IECEx-certified enclosure with a minimum ingress protection rating of at least IP54 as defined in IEC/EN 60079-15.



Caution The enclosure must have a door or cover accessible only by the use of a tool.

Electromagnetic Compatibility Guidelines

This product was tested and complies with the regulatory requirements and limits for electromagnetic compatibility (EMC) stated in the product specifications. These requirements and limits provide reasonable protection against harmful interference when the product is operated in the intended operational electromagnetic environment.

This product is intended for use in industrial locations. However, harmful interference may occur in some installations, when the product is connected to a peripheral device or test object, or if the product is used in residential or commercial areas. To minimize interference with radio and television reception and prevent unacceptable performance degradation, install and use this product in strict accordance with the instructions in the product documentation.

Furthermore, any changes or modifications to the product not expressly approved by National Instruments could void your authority to operate it under your local regulatory rules.

Special Conditions for Marine Applications

Some products are Lloyd's Register (LR) Type Approved for marine (shipboard) applications. To verify Lloyd's Register certification for a product, visit ni.com/certification and search for the LR certificate, or look for the Lloyd's Register mark on the product.



Caution In order to meet the EMC requirements for marine applications, install the product in a shielded enclosure with shielded and/or filtered power and input/output ports. In addition, take precautions when designing, selecting, and installing measurement probes and cables to ensure that the desired EMC performance is attained.

Preparing the Environment

Ensure that the environment in which you are using the NI 9242 meets the following specifications.

Operating temperature (IEC 60068-2-1, IEC 60068-2-2)	-40 °C to 70 °C
---------------------------------------------------------	-----------------

Operating humidity (IEC 60068-2-78)	10% RH to 90% RH, noncondensing
----------------------------------------	------------------------------------

Pollution Degree	2
------------------	---

Maximum altitude	5,000 m
------------------	---------

Indoor use only.



Note Refer to the device datasheet on ni.com/manuals for complete specifications.

NI 9242 Pinout

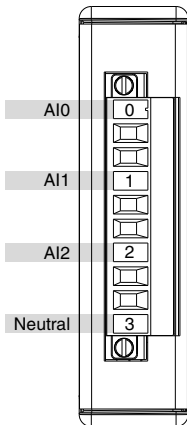

Table 1. Signal Descriptions

Signal	Description
AI	Analog input signal connection referenced to the Neutral signal
Neutral	Referenced, single-ended analog input connection

Connecting Phase Measurements

The NI 9242 accepts three-phase and single-phase measurement configuration.

Three-Phase Measurement Configurations

NI recommends the following three-phase connection types.

4-Wire WYE Measurement Configuration

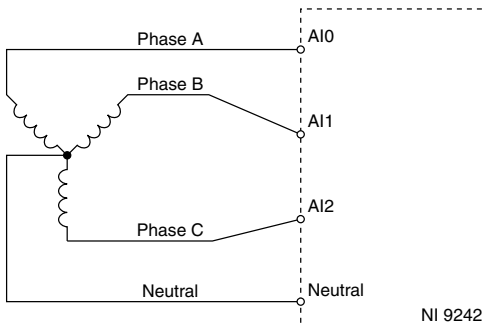

High-Leg Delta Measurement Configuration

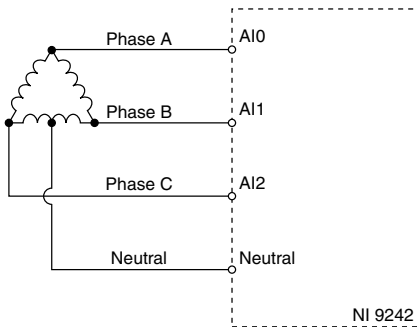

3-Wire Delta Measurement Configuration

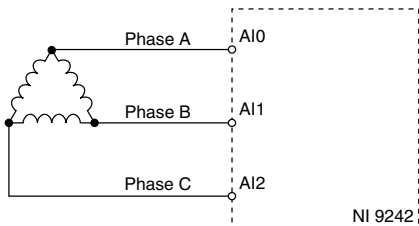

Corner Grounded 2-Wire Delta Measurement Configuration

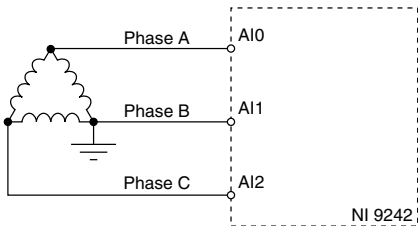

Corner grounded 2-wire delta measurement configurations support only standard service levels up to 240 Vrms L-L.

Connecting Single-Phase Measurement Configurations

NI recommends the following single-phase connection types.

3-Wire Measurement (Split Phase) Configuration

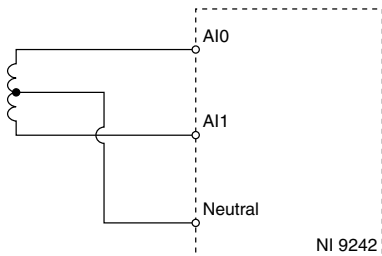

2-Wire Measurement

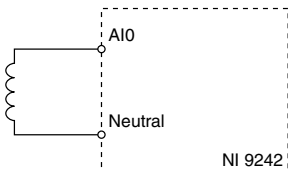

Potential Transformer Connections

The NI 9242 accepts the following potential transformer connections.

4-Wire WYE-to-WYE (Full)

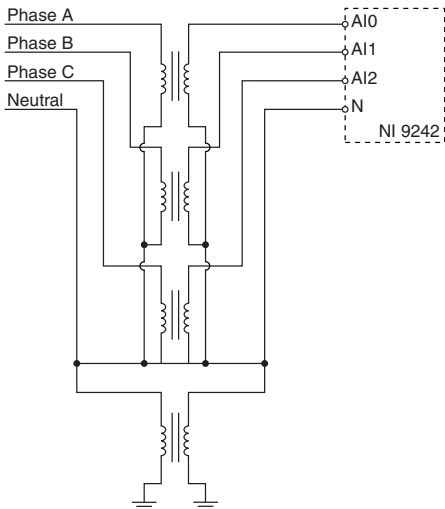

In a 4-wire WYE-to-WYE (full) configuration, the Neutral terminal on the NI 9242 measures the neutral-to-ground voltage through the bottom transformer. You can use a lower ratio transformer due to the typically low voltages on the Neutral terminal. Ensure that you scale each NI 9242 channel reading with the corresponding transformer ratio.

4-Wire WYE-to-WYE (Partial)

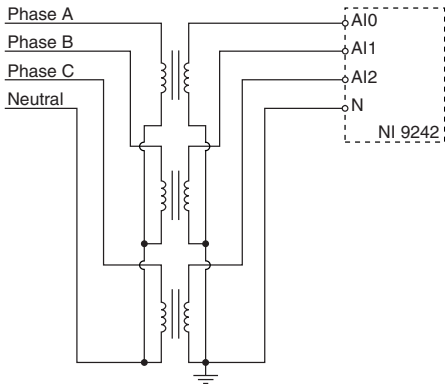

Delta-to-Delta

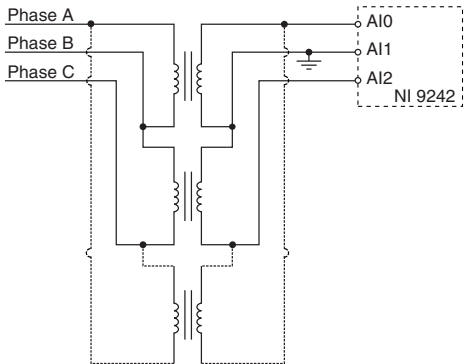

Note You can use the Neutral channel for any other measurement if the measurement does not exceed the Neutral-to-Earth and L-N input range.

Delta-to-WYE

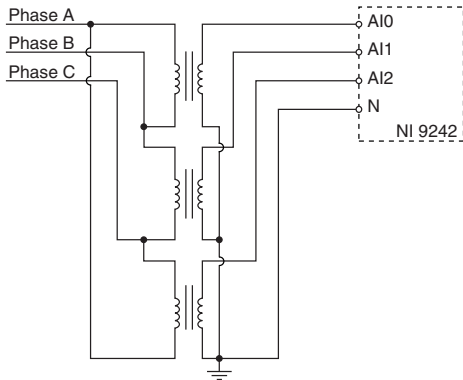

3-Wire WYE-to-Delta

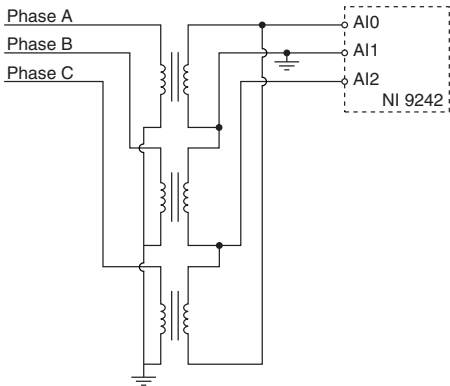

Note You can use the Neutral channel for any other measurement if the measurement does not exceed the Neutral-to-Earth and L-N input range.

3-Wire WYE-to-WYE

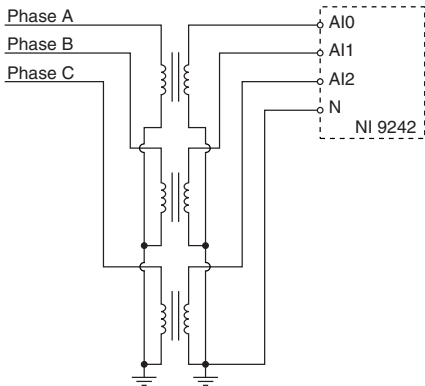

Potential Transformer Ratio Scaling

When measuring voltages using potential transformers, scale the NI 9242 readings with your application software using the

transformer ratio to get readings that refer to the primary of the potential transformers.



Tip If using a 320:1 ratio potential transformer, multiply the readings by 320.

Connection Guidelines

- You must use 2-wire ferrules to create a secure connection when connecting more than one wire to a single terminal on the NI 9242.
- Make sure that devices you connect to the NI 9242 are compatible with the module specifications.

To ensure that measurements to chassis ground are correct, NI recommends connecting the chassis to earth ground using the chassis grounding screw. Refer to your chassis manual for information about connecting the chassis to earth ground.

For 4-wire WYE-to-WYE (partial) configurations, delta-to-WYE configurations, and 3-wire WYE-to-WYE configurations, follow these guidelines for the best accuracy results.

- Connect the Neutral terminal of the NI 9242 to the isolated ground of the potential transformer to reduce noise between the potential transformer ground and the chassis ground.
- Connect the Neutral terminal of the NI 9242 as close as possible to the isolated ground of the potential transformer.
- Use the L-N voltage measurements the NI 9242 returns as the default value.



Note You can convert L-N measurements to channel-to-earth ground by adding the Neutral terminal measurements to each of the AI channels.

High-Vibration Application Connections

If your application is subject to high vibration, NI recommends that you follow these guidelines to protect connections to the NI 9242:

- Use ferrules to terminate wires to the detachable connector.
- Use the NI 9967 backshell kit.

Wiring the NI 9967



Caution For safe operation with hazardous voltages, you must use the NI 9967 Connector Backshell with the 4-terminal connector on the NI 9242.

Complete the appropriate procedure for each wire gauge.

Installing the NI 9967 Using 12 AWG to 14 AWG Wire

What to Use

- NI 9967 backshell
- 12 AWG to 14 AWG wire
- Smallest strain-relief piece
- Screwdriver

What to Do

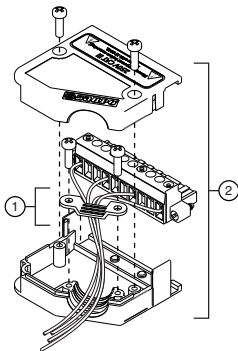

1. Route wires under the smallest strain-relief piece.
2. Secure the smallest strain-relief piece and the backshell in place using captive screws.

Installing the NI 9967 Using 16 AWG Wire

What to Use

- NI 9967 backshell
- 16 AWG wire
- Small and large strain-relief pieces
- Screwdriver

What to Do

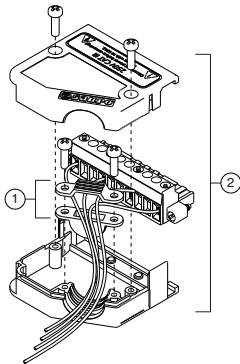

1. Route wires between the two strain-relief pieces, with the small strain-relief piece on top of the wires and the large strain-relief piece underneath the wires.
2. Secure the strain-relief pieces and the backshell in place using captive screws.

Installing the NI 9967 Using 18 AWG to 24 AWG Wire

What to Use

- NI 9967 backshell
- 18 AWG to 24 AWG wire
- Largest strain-relief piece
- Screwdriver

What to Do

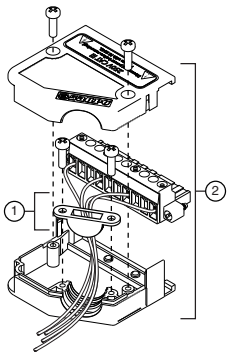

1. Route wires under the largest strain-relief piece.
2. Secure the largest strain-relief piece and the backshell in place using captive screws.

Converting L-N Measurements to L-L

To convert L-N measurements to L-L values, calculate the voltage difference between the AI channels using your application software.

Refer to the following equation for an example of converting L-N measurements to L-L.

$$\text{Phase A to Phase B Voltage} = \text{AI0} - \text{AI1}$$

where

AI0 is the reading from Phase A

AI1 is the reading from Phase B

Converting L-N Measurements to L-Earth

To convert L-N measurements to L-Earth values, add the neutral channel reading to each AI channel reading.

Refer to the following equation for an example of converting L-N measurements to L-Earth.

$$\text{Line to Earth} = \text{AIx} + \text{Neutral}$$

where

A_{Ix} is the analog input channel reading

Neutral is the Neutral channel reading

Where to Go Next

CompactRIO

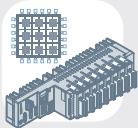

NI 9242 Datasheet



NI-RIO Help



LabVIEW FPGA Help

NI CompactDAQ



NI 9242 Datasheet



NI-DAQmx Help



LabVIEW Help

RELATED INFORMATION



**C Series Documentation
& Resources**

ni.com/info/cseriesdoc



Services

ni.com/services



Located at ni.com/manuals



Installs with the software

Worldwide Support and Services

The NI website is your complete resource for technical support. At ni.com/support, you have access to everything from troubleshooting and application development self-help resources to email and phone assistance from NI Application Engineers.

Visit ni.com/services for NI Factory Installation Services, repairs, extended warranty, and other services.

Visit ni.com/register to register your NI product. Product registration facilitates technical support and ensures that you receive important information updates from NI.

A Declaration of Conformity (DoC) is our claim of compliance with the Council of the European Communities using the manufacturer's declaration of conformity. This system affords the user protection for electromagnetic compatibility (EMC) and product safety. You can obtain the DoC for your product by visiting ni.com/certification. If your product supports calibration, you can obtain the calibration certificate for your product at ni.com/calibration.

NI corporate headquarters is located at 11500 North Mopac Expressway, Austin, Texas, 78759-3504. NI also has offices located around the world. For telephone support in the United States, create your service request at ni.com/support or dial 1 866 ASK MYNI (275 6964). For telephone support outside the United States, visit the *Worldwide Offices* section of ni.com/niglobal to access the branch office websites, which provide up-to-date contact information, support phone numbers, email addresses, and current events.

Refer to the *NI Trademarks and Logo Guidelines* at ni.com/trademarks for information on NI trademarks. Other product and company names mentioned herein are trademarks or trade names of their respective companies. For patents covering NI products/technology, refer to the appropriate location: **Help»Patents** in your software, the `patents.txt` file on your media, or the *National Instruments Patent Notice* at ni.com/patents. You can find information about end-user license agreements (EULAs) and third-party legal notices in the readme file for your NI product. Refer to the *Export Compliance Information* at ni.com/legal/export-compliance for the NI global trade compliance policy and how to obtain relevant HTS codes, ECCNs, and other import/export data. NI MAKES NO EXPRESS OR IMPLIED WARRANTIES AS TO THE ACCURACY OF THE INFORMATION CONTAINED HEREIN AND SHALL NOT BE LIABLE FOR ANY ERRORS. U.S. Government Customers: The data contained in this manual was developed at private expense and is subject to the applicable limited rights and restricted data rights as set forth in FAR 52.227-14, DFAR 252.227-7014, and DFAR 252.227-7015.

© 2016 National Instruments. All rights reserved.