

COMPREHENSIVE SERVICES

We offer competitive repair and calibration services, as well as easily accessible documentation and free downloadable resources.

SELL YOUR SURPLUS

We buy new, used, decommissioned, and surplus parts from every NI series. We work out the best solution to suit your individual needs.

 Sell For Cash  Get Credit  Receive a Trade-In Deal

OBSOLETE NI HARDWARE IN STOCK & READY TO SHIP

We stock **New**, **New Surplus**, **Refurbished**, and **Reconditioned** NI Hardware.



Bridging the gap between the manufacturer and your legacy test system.

 1-800-915-6216

 www.apexwaves.com

 sales@apexwaves.com

All trademarks, brands, and brand names are the property of their respective owners.

Request a Quote

 **CLICK HERE**

PXIe-4080

CALIBRATION PROCEDURE

PXIe-4080/4082

PXIe, 6½-Digit, ±300 V, Onboard 1.8 MS/s Isolated Digitizer, L and C Measurement Support, PXI Digital Multimeter

This document contains the verification and adjustment procedures for the PXIe-4080/4082. Refer to ni.com/calibration for more information about calibration solutions.

Contents

Required Software.....	2
Related Documentation.....	2
Password.....	2
Calibration Interval.....	2
Test Equipment.....	2
Calibration Procedures.....	3
Initial Setup.....	4
Test Conditions.....	4
As-Found and As-Left Limits.....	5
Verification.....	5
Verifying DC Voltage.....	5
Verifying AC Voltage.....	7
Verifying 4-Wire Resistance.....	10
Verifying 2-Wire Resistance.....	11
Verifying DC Current.....	14
Verifying AC Current.....	16
Verifying Capacitance and Inductance.....	17
Adjustment.....	18
Adjusting DC Voltage.....	18
Adjusting Resistance.....	19
Adjusting AC Voltage.....	23
Adjusting Current.....	25
Adjusting Capacitance and Inductance.....	26
Completing the Adjustment Procedures.....	27
Reverification.....	27
Worldwide Support and Services.....	27

Required Software

Calibrating the PXIe-4080/4082 requires you to install the following software on the calibration system:

- NI-DMM version 15.2 or later

You can download all required software from ni.com/downloads.

Related Documentation

For additional information, refer to the following documents as you perform the calibration procedure:

- *NI Digital Multimeters Help*
- *NI PXIe-4080/4081/4082 Getting Started Guide*
- *PXIe-4080 Specifications*
- *PXIe-4082 Specifications*

Visit ni.com/manuals for the latest versions of these documents.

Password

The default password for password-protected operations is NI.

Calibration Interval

Recommended calibration interval	2 years
----------------------------------	---------

Test Equipment

The following table lists the equipment required for calibrating your device. If you do not have the recommended instruments, use these specifications to select a substitute calibration standard.

Equipment	Recommended Models	Where Used	Minimum Requirements
Multifunction calibrator	Fluke 5720A or Fluke 5730A	Voltage, Current, Resistance	Maintained at 90 day specifications
Two sets of low thermal electromotive force (EMF) copper cables	Fluke 5440	Voltage, Current (1 set), Resistance (2 sets)	Shielded twisted pair copper cables with copper or gold-plated copper banana plugs
Banana shorting bar	Pomona 5145	DCV, 2-Wire Resistance	$\leq 40 \text{ m}\Omega$ resistance
Double banana plug with binding posts	Pomona 5405	2-Wire Resistance	Gold-plated copper
Two insulated low thermal EMF spade lugs	Pomona 2305	2-Wire Resistance	Gold-plated copper
25 Ω , 125 Ω , 5 k Ω , 100 k Ω resistors		Capacitance and Inductance (adjustment only)	<ul style="list-style-type: none"> $\leq 1 \%$ tolerance $\leq 5 \text{ ppm/C}$ temperature coefficient $\leq 1 \text{ inch}$ from resistor to DMM terminals
270 pF, 1 nF, 100 nF, 10 μF , 1000 μF capacitors	IET SCA series	Capacitance	$\leq 0.1\%$ uncertainty
Banana-to-banana coax cable	Pasternack PE3005	Capacitance	$\leq 40 \text{ pF}$

Calibration Procedures

The calibration process includes the following steps:

- *Initial Setup* - Set up the test equipment.
- *Verification Procedures* - Verify the existing operation of the device. This step confirms whether the device is operating within its specified range prior to calibration.

- *Adjustment Procedures* - Perform an external adjustment of the device that adjusts the calibration constants with respect to standards of known values.
- *Reverification* - Repeat the verification procedure to ensure that the device is operating within its specifications after adjustment.

Initial Setup



Note Ensure that both the calibrator and the PXIe-4080/4082 are warmed up for at least 60 minutes before you begin this procedure.

To set up the test equipment, complete the following steps:

1. Remove all connections from the four inputs on the PXIe-4080/4082.
2. Verify that the calibrator has been calibrated within the time limits specified in the *Test Equipment* section, and that DC zeros calibration has been performed within the last 30 days. Consult the calibrator user documentation for instructions.

Test Conditions

The following setup and environmental conditions are required to ensure the PXIe-4080/4082 meets published specifications:

- Ensure that the PXI Express chassis fan speed is set to HIGH and that the fan filters are clean.
- Use PXI Express filler panels in all vacant slots to allow proper cooling.
- Plug the PXI Express chassis and the calibrator into the same power strip to avoid ground loops.
- Power on and warm up both the calibrator and the PXIe-4080/4082 for at least 60 minutes before beginning this calibration procedure.
- Maintain an ambient temperature of 23 ± 1 °C.
- Maintain an ambient relative humidity of less than 80%.
- Allow the calibrator to settle fully before taking any measurements. Consult the calibrator user documentation for instructions.
- Allow the thermal EMF enough time to stabilize when you change connections to the calibrator or the PXIe-4080/4082. The suggested time periods are stated where necessary throughout this document.
- Keep a shorting bar connected between the V-GUARD and GROUND binding posts of the calibrator at all times.
- Clean any oxidation from the banana plugs on the cables before plugging them into the binding posts of the calibrator or the connectors of the PXIe-4080/4082. Oxidation

tarnishes the copper plugs so that they appear dull rather than shiny and leads to greater thermal EMF.

- Prevent the cables from moving or vibrating by taping or strapping them to a nonvibrating surface. Movement or vibration causes triboelectric effects that can result in measurement errors.

As-Found and As-Left Limits

The *as-found limits* are the published 2-year specifications for the device. NI uses these limits to determine whether the device meets the device specifications when it is received for calibration.

The *as-left limits* are based on the published 24-hour specifications for the device, with consideration for measurement uncertainty. NI uses these limits to determine whether the device will meet the device specifications over its calibration interval.

Where a TUR of less than 4:1 was determined, a guardband technique was applied to the test limits to maintain the same Probability of False Accepts (PFA) as if it was 4:1. The method selected was the ANSI/NCSL Z540.3 method 6: Guard Bands Based on Test Uncertainty Ratio.

Verification

The performance verification procedures assume that adequate traceable uncertainties are available for the calibration references.

You can use the verification procedures described in this section for both pre-adjustment and post-adjustment verification. You can omit sections (for example, the *Verifying AC Current* section), however, any function not verified during post-adjustment will no longer be traceable and should not be used for measurements.



Note Self-calibrate the PXIe-4080/4082 before performing verification procedures.

Verifying DC Voltage

Complete the following steps to verify DC voltage:

1. Plug in the shorting bar across the HI and LO terminals on the PXIe-4080/4082.
2. Wait two minutes for thermal EMF to stabilize.
3. Reset the PXIe-4080/4082.
4. Initialize the PXIe-4080/4082 for DC Voltage with a range of 100 mV and resolution of 6.5 digits.
5. Verify the accuracy for each configuration in the following table:
 - a) Acquire the measurement at each specified range and input resistance.
 - b) Compare to the specified limits.

DMM Settings		As-Found Limits		As-Left Limits	
Range	Input Resistance	Lower	Upper	Lower	Upper
100 mV	>10 GΩ/10 MΩ	-4.0 μV	4.0 μV	-3.0 μV	3.0 μV
1 V	>10 GΩ/10 MΩ	-8 μV	8 μV	-4 μV	4 μV
10 V	>10 GΩ/10 MΩ	-0.06 mV	0.06 mV	-0.02 mV	0.02 mV
100 V	10 MΩ	-0.6 mV	0.6 mV	-0.2 mV	0.2 mV
300 V	10 MΩ	-6 mV	6 mV	-2 mV	2 mV

- Remove the shorting bar from the PXIe-4080/4082.
- Set the calibrator to Standby.
- Connect the PXIe-4080/4082 to the calibrator using low thermal EMF cables according to the following figure.

Figure 1. Voltage Connection Configuration

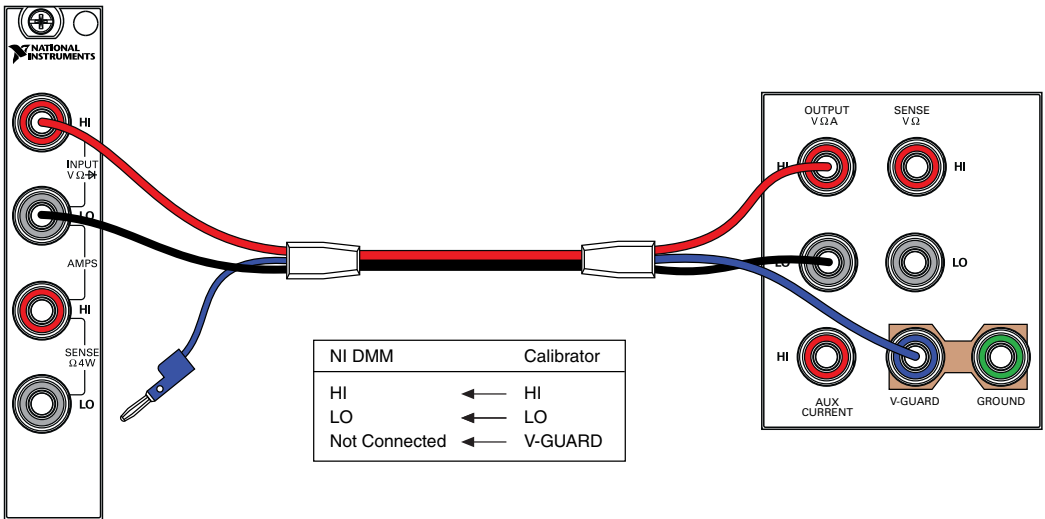

- Wait two minutes for the thermal EMF to stabilize.
- Set the PXIe-4080/4082 and Calibrator configuration as shown the following table.
- Acquire the specified measurements and record them for use as the offset nulls in the following steps.

DMM Settings		Calibrator Settings	
Range	Input Resistance	Range	DCV Amplitude
100 mV	> 10 GΩ	2.2 V	0 V
100 mV	10 MΩ	2.2 V	0 V

12. Verify the accuracy for each configuration in the following table:
 - a) Set the PXIe-4080/4082 to the specified configuration and commit.
 - b) Set the calibrator to the specified configuration and allow it to settle.
 - c) Acquire the specified measurement.
 - d) Subtract the appropriate offset null you recorded previously and compare the result to the limits.
 - e) Repeat for each listed input resistance.
 - f) Set the calibrator to `Standby`.

DMM Settings		Calibrator Settings	As-Found Limits (V)		As-Left Limits (V)	
Range	Input Resistance	DCV Amplitude ¹	Lower	Upper	Lower	Upper
100 mV	>10 GΩ/ 10 MΩ	100 mV	0.0999935	0.1000065	0.0999971	0.1000029
		-100 mV	-0.1000065	-0.0999935	-0.1000029	-0.0999971
1 V	>10 GΩ/ 10 MΩ	1 V	0.999969	1.000031	0.999989	1.000011
		-1 V	-1.000031	-0.999969	-1.000011	-0.999989
10 V	>10 GΩ/ 10 MΩ	10 V	9.99969	10.00031	9.99993	10.00007
		-10 V	-10.00031	-9.99969	-10.00007	-9.99993
100 V	10 MΩ	100 V	99.9959	100.0041	99.9989	100.0011
		-100 V	-100.0041	-99.9959	-100.0011	-99.9989
300 V	10 MΩ	300 V	299.984	300.017	299.995	300.005
		-300 V	-300.017	-299.984	-300.005	-299.995

You have completed verifying the DC voltage mode of the PXIe-4080/4082. Select one of the following options:

- If you want to continue verifying other modes, go to the *Verifying AC Voltage* section.
- If you do not want to verify any additional modes, and you are performing a pre-adjustment verification, close the session.
- If you do not want to verify any additional modes, and you want to update the verification time stamp, complete the following steps:
 1. Open a new calibration session to the instrument (with correct calibration password).
 2. Close the calibration session with the **Action** set to `Save`.

Verifying AC Voltage

Complete the following steps to verify AC voltage:

1. Set the calibrator to `Standby` mode.

¹ For the ± 100 mV test points, lock the calibrator range to 2.2 V.

2. Connect the PXIe-4080/4082 to the calibrator using low leakage cables, as shown in *Figure 1*, on page 6.
3. Reset the PXIe-4080/4082.
4. Initialize the PXIe-4080/4082 for AC Voltage with a range of 50 mV and resolution of 6.5 digits.
5. Verify the accuracy for each configuration in the following table:
 - a) Set the PXIe-4080/4082 to the listed configuration and commit.
 - b) Set the Calibrator to the listed configuration and allow it to settle.
 - c) Acquire the specified measurement and compare the result to the limits.
 - d) Repeat for each listed coupling.
 - e) Set the calibrator to Standby.

DMM Settings		Calibrator Settings		As-Found Limits (V)	
Range	Coupling	Amplitude	Frequency	Lower	Upper
50 mV	AC / DC	5 mV	1 kHz	0.0049775	0.0050225
	DC	50 mV	30 Hz	0.0499300	0.0500700
	AC / DC	50 mV	50 Hz	0.0499550	0.0500450
		50 mV	1 kHz	0.0499550	0.0500450
500 mV		50 mV	1 kHz	0.049875	0.050125
50 mV		50 mV	20 kHz	0.0499550	0.0500450
		50 mV	50 kHz	0.0499350	0.0500650
		50 mV	100 kHz	0.0497100	0.0502900
		50 mV	300 kHz	0.0484500	0.0515500
500 mV	DC	500 mV	30 Hz	0.499450	0.500550
	AC / DC	500 mV	50 Hz	0.499650	0.500350
500 mV		1 kHz	0.499650	0.500350	
500 mV		1 kHz	0.49875	0.50125	
5 V		500 mV	20 kHz	0.499650	0.500350
500 mV		500 mV	50 kHz	0.499450	0.500550
		500 mV	100 kHz	0.497400	0.502600
		500 mV	300 kHz	0.484750	0.515250

DMM Settings		Calibrator Settings		As-Found Limits (V)	
Range	Coupling	Amplitude	Frequency	Lower	Upper
5 V	DC	5 V	30 Hz	4.99450	5.00550
	AC / DC	5 V	50 Hz	4.99650	5.00350
5 V		1 kHz	4.99650	5.00350	
50 V		5 V	1 kHz	4.9875	5.0125
5 V		5 V	20 kHz	4.99650	5.00350
		5 V	50 kHz	4.99450	5.00550
		5 V	100 kHz	4.97400	5.02600
		5 V	300 kHz	4.84750	5.15250
50 V	DC	50 V	30 Hz	49.9450	50.0550
	AC / DC	50 V	50 Hz	49.9650	50.0350
50 V		1 kHz	49.9650	50.0350	
300 V		50 V	1 kHz	49.915	50.085
50 V		50 V	20 kHz	49.9650	50.0350
		50 V	50 kHz	49.9450	50.0550
		50 V	100 kHz	49.7400	50.2600
		50 V	300 kHz	48.4750	51.5250
300 V	DC	219 V	30 Hz	218.751	219.249
	AC / DC	300 V	50 Hz	299.790	300.210
		219 V	1 kHz	218.831	219.170
		219 V	20 kHz	218.831	219.170
		219 V	50 kHz	218.743	219.257
		219 V	100 kHz	217.845	220.155
		70 V	300 kHz	67.750	72.250

You have completed verifying the AC voltage mode of the PXIe-4080/4082. Select one of the following options:

- If you want to continue verifying other modes, proceed to the *Verifying 4-Wire Resistance* section.
- If you do not want to verify any additional modes and you are performing a pre-adjustment verification, close the session.
- If you do not want to verify any additional modes, and you want to update the verification time stamp, complete the following steps:
 1. Open a new calibration session to the instrument (with correct calibration password).
 2. Close the calibration session with the **Action** set to *Save*.

Verifying 4-Wire Resistance

Complete the following steps to verify 4-wire resistance:

1. Set the calibrator to *Standby*
2. Connect the PXIe-4080/4082 to the calibrator using low thermal EMF cables, as shown in the following figure.

Figure 2. 4-Wire Resistance Connection Configuration

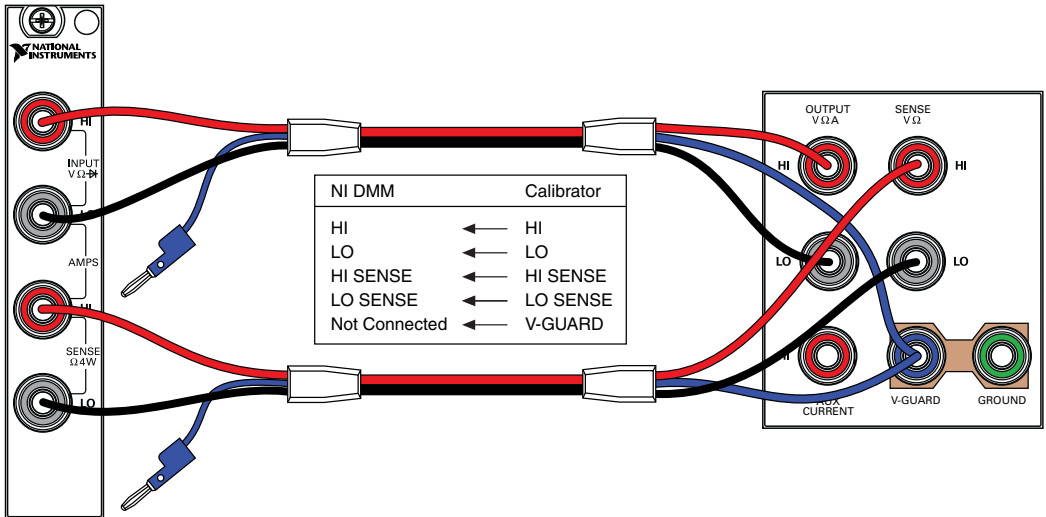

3. Wait two minutes for thermal EMF to stabilize.
4. Reset the PXIe-4080/4082.
5. Configure the PXIe-4080/4082 for 4-wire resistance measurements with a resolution of 6.5 digits.
6. Verify the accuracy for each configuration in the following table:
 - a) Acquire the measurement at each specified configuration.
 - b) Compare to the specified tolerances.



Note Tolerances are provided instead of absolute limits because your calibrator will have different discrete resistance values.

DMM Settings		Calibrator Settings			Tolerances			
					As-Found		As-Left	
Range	Offset Compensated Ohms (OCO)	Resistance	Ext Sense	Comp	ppm of Reading	ppm of Range	ppm of Reading	ppm of Range
10 M Ω	Off	0 Ω	On	None	-	10	-	2
1 M Ω	Off	0 Ω	On	None	-	10	-	2
100 k Ω	Off	0 Ω	On	None	-	8	-	4
10 k Ω	On	0 Ω	On	None	-	3	-	2.2
1 k Ω	On	0 Ω	On	None	-	3	-	2.2
100 Ω	On	0 Ω	On	None	-	13.4	-	11.2
10 M Ω	Off	10 M Ω	On	None	800	10	100	2
1 M Ω	Off	1 M Ω	On	None	95	10	32	2
100 k Ω	Off	100 k Ω	On	None	95	6	15	2
10 k Ω	On	10 k Ω	On	None	80	3	12	2.2
1 k Ω	On	1 k Ω	On	None	80	3	18	2.2
100 Ω	On	100 Ω	On	None	82	13.4	23	11.2



Note Apply an offset null to the 100 k Ω measurement by subtracting the corresponding 0 Ω measurement in the 100 k Ω range.

You have completed verifying the 4-wire resistance mode of the PXIe-4080/4082. Select one of the following options:

- If you want to continue verifying other modes, go to the *Verifying 2-Wire Resistance* section.
- If you do not want to verify any additional modes and you are performing a pre-adjustment verification, close the session.
- If you do not want to verify any additional modes, and you want to update the verification time stamp, complete the following steps:
 1. Open a new calibration session to the instrument (with correct calibration password).
 2. Close the calibration session with the **Action** set to *Save*.

Verifying 2-Wire Resistance

Complete the following steps to verify 2-wire resistance:

1. Plug in the shorting bar across the HI and LO terminals on the PXIe-4080/4082.

2. Wait two minutes for thermal EMF to stabilize.
3. Reset the PXIe-4080/4082.
4. Verify the accuracy for each configuration in the following table:
 - a) Acquire the measurement at each specified configuration.
 - b) Compare to the specified tolerances.

DMM Settings		Tolerances (ppm of range)	
Range	OCO	As-Found	As-Left
100 MΩ	Off	10	10
10 MΩ	Off	10	2
1 MΩ	Off	10	2
100 kΩ	Off	10	6
10 kΩ	On	23	22
1 kΩ	On	203	202
100 Ω	On	2015	2010

5. Remove the shorting bar from the PXIe-4080/4082.
6. Set the calibrator to *Standby*.
7. Connect the PXIe-4080/4082 to the calibrator using low thermal EMF cables, as shown in [Figure 1](#), on page 6.
8. Wait two minutes for thermal EMF to stabilize.
9. Verify the accuracy for each configuration in the following table:
 - a) Acquire the measurement at each specified configuration.
 - b) Compare to the specified tolerances.

DMM Settings		Calibrator Settings			Tolerances			
Range	OCO	Resistance	Ext Sense	Comp	As-Found		As-Left	
					ppm of Reading	ppm of Range	ppm of Reading	ppm of Range
1 MΩ	Off	0 Ω	Off	None	-	-	-	-
100 kΩ	Off	0 Ω	Off	None	-	-	-	-
100 MΩ	Off	100 MΩ	Off	None	3000	10	500	10
10 MΩ	Off	10 MΩ	Off	None	800	10	100	2

DMM Settings		Calibrator Settings			Tolerances			
					As-Found		As-Left	
Range	OCO	Resistance	Ext Sense	Comp	ppm of Reading	ppm of Range	ppm of Reading	ppm of Range
1 M Ω	Off	1 M Ω	Off	None	95	10	32	2
100 k Ω	Off	100 k Ω	Off	None	95	6	15	2



Note For the 1 M Ω and 100 k Ω measurements, subtract the corresponding 0 Ω measurement as an offset null.

10. Connect the PXIe-4080/4082 to the calibrator using low thermal EMF cables, as shown in the following figure.

Figure 3. 2-Wire Resistance Low Range Connection Configuration

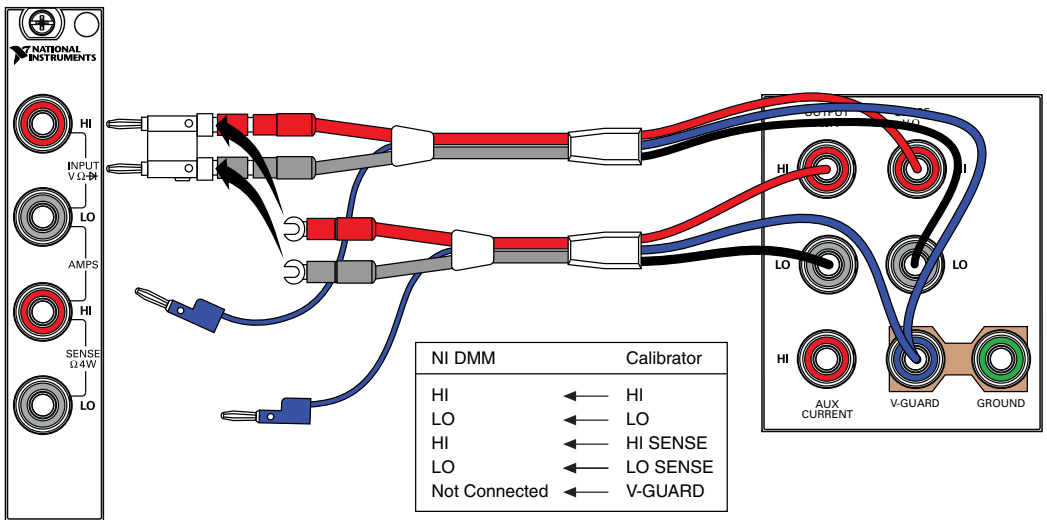

11. Wait two minutes for the thermal EMF to stabilize.
12. Verify the accuracy for each configuration in the following table:
 - a) Acquire the measurement at each specified configuration.
 - b) Compare to the specified tolerances.

DMM Settings		Calibrator Settings			Tolerances			
					As-Found		As-Left	
Range	OCO	Resistance	Ext Sense	Comp	ppm of Reading	ppm of Range	ppm of Reading	ppm of Range
10 k Ω	Off	10 k Ω	On	2-Wire	80	23	12	22
1 k Ω	Off	1 k Ω	On	2-Wire	80	203	12	202
100 Ω	Off	100 Ω	On	2-Wire	80	2015	15	2010

You have completed verifying the 2-wire resistance mode of the PXIe-4080/4082. Select one of the following options:

- If you want to continue verifying other modes, go to the *Verifying DC Current* section.
- If you are performing a pre-adjustment verification, close the session.
- If you do not want to verify any additional modes, and you want to update the verification time stamp, complete the following steps:
 1. Open a new calibration session to the instrument (with correct calibration password).
 2. Close the calibration session with the **Action** set to *Save*.

Verifying DC Current

Complete the following steps to verify DC current:

1. Unplug all cables from the PXIe-4080/4082.
2. Reset the PXIe-4080/4082.
3. Initialize the PXIe-4080/4082 for DC current with a range of 20 mA and resolution of 6.5 digits.
4. Verify the accuracy for each configuration in the following table:
 - a) Acquire the measurement at each specified range.
 - b) Compare to the specified limits.

DMM Range	As-Found Limits		As-Left Limits	
	Lower	Upper	Lower	Upper
20 mA	-4.00 μ A	4.00 μ A	-0.30 μ A	0.30 μ A
200 mA	-4.0 μ A	4.0 μ A	-3.0 μ A	3.0 μ A
1 A	-50 μ A	50 μ A	-15 μ A	15 μ A

5. Set the calibrator to *Standby*.
6. Connect the PXIe-4080/4082 to the calibrator using low leakage cables according to the configuration in the following figure.

Figure 4. DC Current Connection Configuration

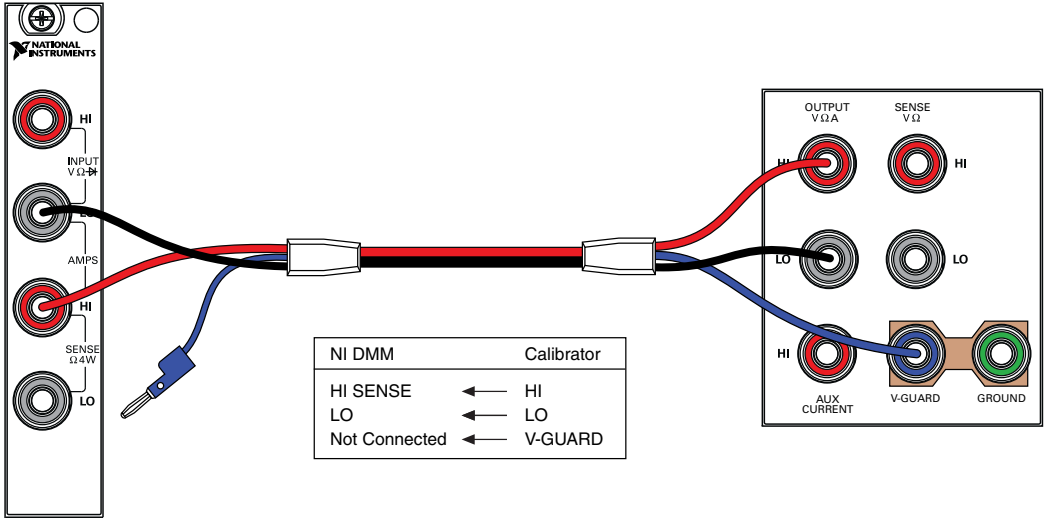

7. Verify the accuracy for each configuration in the following table:
 - a) Set the PXIe-4080/4082 to the listed configuration and commit.
 - b) Set the calibrator to the listed configuration and allow it to settle.
 - c) Acquire the specified measurement and compare to the limits.
 - d) Set the calibrator to Standby after you have completed all test points in the DMM Range.

DMM Range	Calibrator Output	As-Found Limits (A)		As-Left Limits (A)	
		Lower	Upper	Lower	Upper
20 mA	18 mA	0.01798790	0.01801210	0.01799902	0.01800098
20 mA	-18 mA	-0.01801210	-0.01798790	-0.01800098	-0.01799902
200 mA	180 mA	0.1798970	0.1801030	0.1799894	0.1800106
200 mA	-180 mA	-0.1801030	-0.1798970	-0.1800106	-0.1799894
1 A	900 mA	0.899320	0.900680	0.899942	0.900058
1 A	-900 mA	-0.900680	-0.899320	-0.900058	-0.899942

You have completed verifying the DC current of the PXIe-4080/4082. Select one of the following options:

- If you want to continue verifying other modes, go to the *Verifying AC Current* section.
- If you do not want to verify any additional modes and you are performing a pre-adjustment verification, close the session.
- If you do not want to verify any additional modes, and you want to update the verification time stamp, complete the following steps:
 1. Open a new calibration session to the instrument (with correct calibration password).
 2. Close the calibration session with the **Action** set to *Save*.

Verifying AC Current

Complete the following steps to verify AC current:

1. Set the calibrator to *Standby*.
2. Connect the PXIe-4080/4082 to the calibrator using low leakage cables as shown in *Figure 4*, on page 15.
3. Reset the PXIe-4080/4082.
4. Initialize the PXIe-4080/4082 for AC Current with a range of 10mA and a resolution of 6.5 digits.
5. Verify the accuracy for each configuration in the following table:
 - a) Set the PXIe-4080/4082 to the listed configuration and commit.
 - b) Set the Calibrator to the listed configuration and allow it to settle.
 - c) Acquire the specified measurement and compare to the limits.
 - d) Set the calibrator to *Standby* if you have completed all test points in a DMM Range.

Calibrator Settings		DMM Range	Limits (A)	
Amplitude	Frequency		Lower	Upper
1 mA	1 kHz	10 mA	0.00099760	0.00100240
10 mA	1 kHz	10 mA	0.00999400	0.01000600
10 mA	1 kHz	100 mA	0.0099760	0.0100240
100 mA	55 Hz	100 mA	0.0999400	0.1000600
100 mA	5 kHz	1 A	0.099700	0.100300
1 A	1 kHz	1 A	0.998800	1.001200

You have completed verifying AC current for the PXIe-4080/4082. Select one of the following options:

- If you want to continue verifying the PXIe-4082, go to the *Verifying Capacitance and Inductance* section.
- If you do not want to verify any additional modes and are performing a pre-adjustment verification, close the session.
- If you do not want to verify any additional modes, and you want to update the verification time stamp, complete the following steps:
 1. Open a new calibration session to the instrument (with correct calibration password).
 2. Close the calibration session with the **Action** set to *Save*.

Verifying Capacitance and Inductance

Complete the following steps to verify capacitance and inductance for the PXIe-4082:



Note The PXIe-4082 inductance accuracy is theoretically verified if the capacitance accuracy meets its specification. If you have access to precision inductors, you can verify the inductance measurements by comparing your results with the published accuracy specifications.

You can use different verification capacitors to verify each capacitance range. You can verify two ranges with the same verification capacitor as long as its value is $\geq 10\%$ of the higher capacitance range. For example, you can use a 1 nF verification capacitor to test both the 10 nF and 1 nF ranges.

The following verification procedure assumes the use of verification capacitors with the following values: 270 pF, 1 nF, 100 nF, 10 μ F, and 1000 μ F.

The configuration of the cables and fixtures should be consistent throughout each measurement. If you are using cables to connect the verification capacitors to the inputs of the PXIe-4082, minimize noise by ensuring that the cables remain fixed and do not move during the measurement.

Keep direct contact with the verification capacitors to a minimum so that they are constantly kept at the ambient temperature. After connecting a capacitor to the PXIe-4082, NI recommends waiting 30 seconds for the capacitor temperature to stabilize.



Note You should know the total capacitance up to the banana connectors that plug into the PXIe-4082 before performing the verification procedure.

1. Disconnect any fixtures or cables from the device.
2. Reset the PXIe-4082.
3. Verify the accuracy for each configuration in the following table:
 - a) Connect the indicated standard to the device and wait the recommended settling time.
 - b) Configure the device as indicated in DMM Range and take a measurement.
 - c) Compare the acquired value to the specified tolerances.
 - d) Repeat the previous steps for each standard listed in the table.

Standard	Recommended Settling Time	DMM Range	Tolerance	
			% of Reading	% of Range
OPEN (0 pF)	0 s	300 pF	-	0.6
SHORT (0 μ H)	0 s	10 μ H	-	1
270 pF	30 s	300 pF	0.5	0.6
1 nF	30 s	1 nF	0.4	0.2
1 nF	30 s	10 nF	0.3	0.1
100 nF	30 s	100 nF	0.3	0.1
100 nF	30 s	1 μ F	0.3	0.1
10 μ F	30 s	10 μ F	0.3	0.1
10 μ F	30 s	100 μ F	0.3	0.1
1,000 μ F	30 s	1,000 μ F	0.4	0.1
1,000 μ F	30 s	10,000 μ F	0.3	0.1

You have completed verifying the capacitance and inductance of the PXIe-4082. Select one of the following options:

- If you are performing a pre-adjustment verification, close the session.
- To update the verification time stamp, complete the following steps:
 1. Open a new calibration session to the instrument (with correct calibration password).
 2. Close the calibration session with the **Action** set to *Save*.

Adjustment

This section explains how to adjust the PXIe-4080/4082. You can choose to perform these adjustment procedures with or without performing the verification procedure first.



Note Repeat the verification procedures after you perform these adjustment procedures. NI recommends that you perform a post-adjustment verification to ensure that the device you have calibrated is operating within specifications after adjustments.



Caution Do not skip any of the steps within a section of the adjustment procedures.

Adjusting DC Voltage

Complete the following steps to adjust DC Voltage:

1. Disconnect all inputs from the PXIe-4080/4082.
2. Reset the calibrator.

3. Initialize an external calibration session to the PXIe-4080/4082.
4. Self-calibrate the PXIe-4080/4082.
5. Connect the PXIe-4080/4082 to the calibrator using low thermal EMF cables according to the configuration shown in *Figure 1*, on page 6.
6. Wait two minutes for thermal EMF to stabilize.
7. Adjust the voltage gain with each configuration in the following table:
 - a) Output the specified voltage from the calibrator.
 - b) Call the niDMM Cal Adjust Gain VI or the niDMM_CalAdjustGain function with the specified DMM settings.

Calibrator Settings	DMM Settings			
	Function	Range	Input Resistance	Expected Value
10 V	DC Volts	10 V	>10 GΩ	10 V
-10 V				-10 V

8. Disconnect the cables from the PXIe-4080/4082, leaving the other end of the cable connected to the calibrator binding posts.
9. Plug in the shorting bar across the HI and LO terminals on the PXIe-4080/4082.
10. Wait two minutes for the thermal EMF to stabilize.
11. Call the niDMM Cal Adjust Misc VI or the niDMM_CalAdjustMisc function with **Type** set to NIDMM_EXTCAL_MISCCAL_VREF_DC_VOLTAGE.
12. Self-calibrate the PXIe-4080/4082.
13. Call the niDMM Cal Adjust Offset VI or the niDMM_CalAdjustOffset function with the following parameters:
 - Function: DC Volts
 - Range: 100 mV
 - Input Resistance: >10 GΩ

You have completed adjusting the DC voltage mode of the PXIe-4080/4082. Proceed to one of the following sections:

- *Adjusting Resistance*
- *Adjusting AC Voltage*
- *Adjusting Current*

If you are not performing additional adjustments, proceed to the *Completing the Adjustment Procedures* section to commit the calibration constants.

Adjusting Resistance



Note You must adjust DC voltage before you adjust resistance.



Note If you do not use the resistance modes for any measurements or the accuracy of these modes is irrelevant, you can skip this section and go directly to the *Adjusting AC Voltage* section.

Complete the following steps to adjust the resistance of the device:

1. Connect the PXIe-4080/4082 to the calibrator using low thermal EMF cables as shown in *Figure 2*, on page 10.
2. Wait two minutes for thermal EMF to stabilize.
3. Adjust the resistance calibration with each configuration in the following table:
 - a) Commit the DMM to the specified range.
 - b) Configure the calibrator as specified.
 - c) Wait the specified settling time.
 - d) Call niDMM Cal Adjust Gain VI or the niDMM_CalAdjustGain function with the specified parameters.

DMM Settings				Calibrator Settings			Minimum Settling Time
Function	Range	Input Resistance	Expected Value	Resistance	Ext. Sense	Comp	
4-wire resistance	10 kΩ	N/A	(value from calibrator)	10 kΩ	On	None	1 s
			(value from calibrator)	0 Ω			1 s
	100 kΩ	N/A	(value from calibrator)	100 kΩ			10 s
			(value from calibrator)	0 Ω			1 s

4. Call the niDMM Cal Adjust Misc VI or the niDMM_CalAdjustMisc function with **Type** set to NIDMM_EXTCAL_MISCCAL_RREF.
5. Adjust the resistance calibration with each configuration in the following table:
 - a) Commit the PXIe-4080/4082 to the specified range.
 - b) Configure the calibrator as specified.
 - c) Wait the specified settling time.
 - d) Call niDMM Cal Adjust Gain VI or the niDMM_CalAdjustGain function with the specified parameters.

DMM Settings				Calibrator Settings			Minimum Settling Time
Function	Range	Input Resistance	Expected Value	Resistance	Ext. Sense	Comp	
4-wire resistance	10 M Ω	N/A	(value from calibrator)	0 Ω	On	None	0 s
			(value from calibrator)	10 M Ω			10 s
2-wire resistance	10 M Ω	N/A	(value from calibrator)	0 Ω	Off	None	0 s
			(value from calibrator)	10 M Ω			10 s

6. Call the niDMM Cal Adjust Misc VI or the niDMM_CalAdjustMisc function with **Type** set to NIDMM_EXTCAL_MISCCAL_RREF.
7. Self-calibrate the PXIe-4080/4082.
8. Adjust the resistance calibration with each configuration in the following table:
 - a) Commit the PXIe-4080/4082 to the specified range.
 - b) Configure the calibrator as specified.
 - c) Wait the specified settling time.
 - d) Call niDMM Cal Adjust Gain VI or the niDMM_CalAdjustGain function with the specified parameters.

DMM Settings				Calibrator Settings			Minimum Settling Time
Function	Range	Input Resistance	Expected Value	Resistance	Ext. Sense	Comp	
2-wire resistance	100 M Ω	N/A	(value from calibrator)	0 Ω	Off	None	0 s
			(value from calibrator)	100 M Ω			10 s
			+Inf	Standby			10 s

9. Output 0 Ω on the calibrator with External Sense turned on and Compensation set to None.
10. Call the niDMM Cal Adjust Offset VI or the niDMM_CalAdjustOffset function for each range in the following table.

DMM Settings		
Function	Input Resistance	Range
4-wire resistance	N/A	100 Ω
		1 k Ω
		10 k Ω
		100 k Ω
		1 M Ω
		10 M Ω

- Call the niDMM Cal Adjust Misc VI or the niDMM_CalAdjustMisc function with **Type** set to NIDMM_EXTCAL_MISCCAL_VREF_RESISTANCE.
- Disconnect all inputs from the PXIe-4080/4082 and plug in the shorting bar between the HI and LO terminals.
- Wait two minutes for the thermal EMF to stabilize.
- Call the niDMM Cal Adjust Offset VI or the niDMM_CalAdjustOffset function for each range in the following table.

DMM Settings		
Function	Input Resistance	Range
2-wire resistance	N/A	100 Ω
		1 k Ω
		10 k Ω
		100 k Ω
		1 M Ω
		10 M Ω
		100 M Ω

You have completed adjusting the resistance of the PXIe-4080/4082. Proceed to one of the following sections:

- *Adjusting AC Voltage*
- *Adjusting Current*
- *Adjusting Capacitance and Inductance*

If you are not performing additional adjustments, proceed to the *Completing the Adjustment Procedures* section to commit your calibration constants.

Adjusting AC Voltage



Note You must adjust DC voltage before you adjust AC voltage.



Note If you do not use the AC voltage modes for any measurements, or the accuracy of these modes is irrelevant, you can skip this section in the calibration procedure and go directly to the *Adjusting Current* section.

Complete the following steps to adjust the AC voltage of the device:

1. Reset the calibrator.
2. Connect the PXIe-4080/4082 to the calibrator as shown in [Figure 1](#), on page 6.
3. Call the niDMM Cal Adjust Misc VI or the niDMM_CalAdjustMisc function with **Type** set to NIDMM_EXTCAL_MISCCAL_VREF_AC_VOLTAGE.
4. Adjust the AC Voltage gain with each configuration in the following table:
 - a) Commit the device to specified range.
 - b) Configure the calibrator as specified and allow it to settle.
 - c) Call the niDMM Cal Adjust AC Filter VI or the niDMM_CalAdjustACFilter function with the specified parameters.

DMM Settings		Calibrator Settings	
Function	Range	Amplitude	Frequency
AC Volts	50 mV	50 mV	1 kHz
			5 kHz
			20 kHz
			50 kHz
			100 kHz
			200 kHz
			300 kHz
			500 kHz

DMM Settings		Calibrator Settings	
Function	Range	Amplitude	Frequency
AC Volts	500 mV	500 mV	1 kHz
			5 kHz
			20 kHz
			50 kHz
			100 kHz
			200 kHz
			300 kHz
			500 kHz
AC Volts	5 V	5 V	1 kHz
			5 kHz
			20 kHz
			50 kHz
			100 kHz
			200 kHz
			300 kHz
			500 kHz
AC Volts	50 V	50 V	1 kHz
			5 kHz
			20 kHz
			50 kHz
			100 kHz
			200 kHz
			300 kHz
			500 kHz
		10 V	500 kHz

DMM Settings		Calibrator Settings	
Function	Range	Amplitude	Frequency
AC Volts	300 V	100 V	1 kHz
			5 kHz
			20 kHz
			50 kHz
			100 kHz
			200 kHz
		50 V	300 kHz
		10 V	500 kHz

- Reset the calibrator.
- Call the `niDMM_Cal Adjust Misc VI` or the `niDMM_CalAdjustMisc` function with **Type** set to `NIDMM_EXTCAL_MISCCAL_VOLTAGE_AC_FILTER`.
- Self-calibrate the PXIe-4080/4082.

You have completed adjusting the AC voltage modes of the PXIe-4080/4082. Proceed to one of the following sections:

- Adjusting Current*
- Adjusting Capacitance and Inductance*

If you are not performing additional adjustments, proceed to the *Completing the Adjustment Procedures* section to commit the calibration constants.

Adjusting Current



Note You must adjust DC voltage before you adjust current.



Note If you do not use the current modes (DC and AC), or the accuracy is insignificant for your application you can skip this section and go directly to the *Adjusting Capacitance and Inductance* section.

Complete the following steps to adjust the current modes of the device:

- Reset the calibrator.
- Disconnect all inputs of the PXIe-4080/4082 .
- Call the `niDMM Cal Adjust Misc VI` or `niDMM_CalAdjustMisc` function with **Type** set to `NIDMM_EXTCAL_MISCCAL_VREF_DC_CURRENT`.
- Repeat the previous step, setting **Type** to `NIDMM_EXTCAL_MISCCAL_VREF_AC_CURRENT`.
- Connect the PXIe-4080/4082 to the calibrator as shown in [Figure 4](#), on page 15.

6. Adjust the current gain with each configuration in the following table:
 - a) Commit the device to the specified range.
 - b) Configure the calibrator to the specified DC output current and allow it to settle.
 - c) Call the niDMM Cal Adjust Gain VI or niDMM_CalAdjustGain function with the specified parameters.
 - d) Set the calibrator to Standby.

DMM Settings			Calibrator Output	Expected Value
Function	Range	Input Resistance		
DC Current	20 mA	N/A	20 mA	20 mA
			-20 mA	-20 mA
	200 mA	N/A	200 mA	200 mA
			-200 mA	-200 mA
	1 A	N/A	1 A	1 A
			-1 A	-1 A

7. Self-calibrate the PXIe-4080/4082.

You have completed adjusting the current modes of the PXIe-4080/4082. To continue adjusting other modes, proceed to the *Adjusting Capacitance and Inductance* section.

If you are finished adjusting modes, proceed to the *Completing the Adjustment Procedures* section to commit the calibration constants.

Adjusting Capacitance and Inductance



Note If you do not use the capacitance or inductance modes for any measurements, or the accuracy of these modes is irrelevant, you can skip this section.



Caution It is necessary to adjust DC voltage and resistance before running these adjustment steps. During this procedure, be sure to keep hands and any other moving objects away from the fixture after calling every function.

Complete the following steps to adjust the capacitance and inductance of the PXIe-4082.

1. Disconnect all inputs of the PXIe-4082.
2. Call the niDMM Cal Adjust LC VI or the niDMM_CalAdjustLC function with **Type** set to NIDMM_EXTCAL_LC_OPEN.
3. Plug in the shorting bar across the HI and LO terminals on the PXIe-4082.
4. Call the niDMM Cal Adjust LC VI or the niDMM_CalAdjustLC function with **Type** set to NIDMM_EXTCAL_LC_SHORT.
5. Remove the shorting bar from the PXIe-4082.

6. Adjust the capacitance and inductance calibration with each standard in the following table:
 - a) Plug the specified resistor between the HI and LO terminals of the PXIe-4082. The leads between the resistor and the PXIe-4082 should be ≤ 1 inch.
 - b) Wait 30 seconds for thermal EMF to stabilize.
 - c) Call the niDMM Cal Adjust LC VI or the `niDMM_CalAdjustLC` function with the specified Type parameter.

Value of Resistor	niDMM Cal Adjust LC Parameter - Type
25 Ω	NIDMM_EXTCAL_LC_25OHM
125 Ω	NIDMM_EXTCAL_LC_125OHM
5 k Ω	NIDMM_EXTCAL_LC_5KOHM
100 k Ω	NIDMM_EXTCAL_LC_100KOHM

You have completed adjusting the capacitance and inductance modes of the PXIe-4082. Proceed to the *Completing the Adjustment Procedures* section to commit the calibration constants.

Completing the Adjustment Procedures

To complete the adjustment procedure for the PXIe-4080/4082 and close the session, call the niDMM Close Ext Cal VI or the `niDMM_CloseExtCal` function with the following parameter:

- Action = NIDMM_EXTCAL_ACTION_SAVE if you want to save the new calibration coefficients to the device. Otherwise,
- Action = NIDMM_EXTCAL_ACTION_ABORT if you want to restore the original calibration coefficients to the device.

Reverification

Repeat the *Verification* section to determine the as-left status of the PXIe-4080/4082.



Note If any test fails reverification after performing an adjustment, verify that you have met the test conditions before returning your PXIe-4080/4082 to NI. Refer to the *Worldwide Support and Services* section for information about support resources or service requests.

Worldwide Support and Services

The NI website is your complete resource for technical support. At ni.com/support, you have access to everything from troubleshooting and application development self-help resources to email and phone assistance from NI Application Engineers.

Visit ni.com/services for NI Factory Installation Services, repairs, extended warranty, and other services.

Visit ni.com/register to register your NI product. Product registration facilitates technical support and ensures that you receive important information updates from NI.

A Declaration of Conformity (DoC) is our claim of compliance with the Council of the European Communities using the manufacturer's declaration of conformity. This system affords the user protection for electromagnetic compatibility (EMC) and product safety. You can obtain the DoC for your product by visiting ni.com/certification. If your product supports calibration, you can obtain the calibration certificate for your product at ni.com/calibration.

NI corporate headquarters is located at 11500 North Mopac Expressway, Austin, Texas, 78759-3504. NI also has offices located around the world. For telephone support in the United States, create your service request at ni.com/support or dial 1 866 ASK MYNI (275 6964). For telephone support outside the United States, visit the *Worldwide Offices* section of ni.com/global to access the branch office websites, which provide up-to-date contact information, support phone numbers, email addresses, and current events.

Information is subject to change without notice. Refer to the *NI Trademarks and Logo Guidelines* at ni.com/trademarks for information on NI trademarks. Other product and company names mentioned herein are trademarks or trade names of their respective companies. For patents covering NI products/technology, refer to the appropriate location: **Help»Patents** in your software, the `patents.txt` file on your media, or the *National Instruments Patent Notice* at ni.com/patents. You can find information about end-user license agreements (EULAs) and third-party legal notices in the `readme` file for your NI product. Refer to the *Export Compliance Information* at ni.com/legal/export-compliance for the NI global trade compliance policy and how to obtain relevant HTS codes, ECCNs, and other import/export data. NI MAKES NO EXPRESS OR IMPLIED WARRANTIES AS TO THE ACCURACY OF THE INFORMATION CONTAINED HEREIN AND SHALL NOT BE LIABLE FOR ANY ERRORS. U.S. Government Customers: The data contained in this manual was developed at private expense and is subject to the applicable limited rights and restricted data rights as set forth in FAR 52.227-14, DFAR 252.227-7014, and DFAR 252.227-7015.

© 2016—2017 National Instruments. All rights reserved.

375281B-01 March 21, 2017