

COMPREHENSIVE SERVICES

We offer competitive repair and calibration services, as well as easily accessible documentation and free downloadable resources.

SELL YOUR SURPLUS

We buy new, used, decommissioned, and surplus parts from every NI series. We work out the best solution to suit your individual needs.

 Sell For Cash  Get Credit  Receive a Trade-In Deal

OBSOLETE NI HARDWARE IN STOCK & READY TO SHIP

We stock **New**, **New Surplus**, **Refurbished**, and **Reconditioned** NI Hardware.



Bridging the gap between the manufacturer and your legacy test system.

 1-800-915-6216

 www.apexwaves.com

 sales@apexwaves.com

All trademarks, brands, and brand names are the property of their respective owners.

Request a Quote

 **CLICK HERE**

PXIe-1085

PXI Express™

NI PXIe-1085 Series User Manual

Worldwide Technical Support and Product Information

ni.com

Worldwide Offices

Visit ni.com/niglobal to access the branch office websites, which provide up-to-date contact information, support phone numbers, email addresses, and current events.

National Instruments Corporate Headquarters

11500 North Mopac Expressway Austin, Texas 78759-3504 USA Tel: 512 683 0100

For further support information, refer to the *NI Services* appendix. To comment on NI documentation, refer to the NI website at ni.com/info and enter the Info Code `feedback`.

© 2012–2018 National Instruments. All rights reserved.

Legal Information

Limited Warranty

This document is provided 'as is' and is subject to being changed, without notice, in future editions. For the latest version, refer to ni.com/manuals. NI reviews this document carefully for technical accuracy; however, NI MAKES NO EXPRESS OR IMPLIED WARRANTIES AS TO THE ACCURACY OF THE INFORMATION CONTAINED HEREIN AND SHALL NOT BE LIABLE FOR ANY ERRORS.

NI warrants that its hardware products will be free of defects in materials and workmanship that cause the product to fail to substantially conform to the applicable NI published specifications for one (1) year from the date of invoice.

For a period of ninety (90) days from the date of invoice, NI warrants that (i) its software products will perform substantially in accordance with the applicable documentation provided with the software and (ii) the software media will be free from defects in materials and workmanship.

If NI receives notice of a defect or non-conformance during the applicable warranty period, NI will, in its discretion: (i) repair or replace the affected product, or (ii) refund the fees paid for the affected product. Repaired or replaced Hardware will be warranted for the remainder of the original warranty period or ninety (90) days, whichever is longer. If NI elects to repair or replace the product, NI may use new or refurbished parts or products that are equivalent to new in performance and reliability and are at least functionally equivalent to the original part or product.

You must obtain an RMA number from NI before returning any product to NI. NI reserves the right to charge a fee for examining and testing Hardware not covered by the Limited Warranty.

This Limited Warranty does not apply if the defect of the product resulted from improper or inadequate maintenance, installation, repair, or calibration (performed by a party other than NI); unauthorized modification; improper environment; use of an improper hardware or software key; improper use or operation outside of the specification for the product; improper voltages; accident, abuse, or neglect; or a hazard such as lightning, flood, or other act of nature.

THE REMEDIES SET FORTH ABOVE ARE EXCLUSIVE AND THE CUSTOMER'S SOLE REMEDIES, AND SHALL APPLY EVEN IF SUCH REMEDIES FAIL OF THEIR ESSENTIAL PURPOSE.

EXCEPT AS EXPRESSLY SET FORTH HEREIN, PRODUCTS ARE PROVIDED "AS IS" WITHOUT WARRANTY OF ANY KIND AND NI DISCLAIMS ALL WARRANTIES, EXPRESSED OR IMPLIED, WITH RESPECT TO THE PRODUCTS, INCLUDING ANY IMPLIED WARRANTIES OF MERCHANTABILITY, FITNESS FOR A PARTICULAR PURPOSE, TITLE OR NON-INFRINGEMENT, AND ANY WARRANTIES THAT MAY ARISE FROM USAGE OF TRADE OR COURSE OF DEALING. NI DOES NOT WARRANT, GUARANTEE, OR MAKE ANY REPRESENTATIONS REGARDING THE USE OF OR THE RESULTS OF THE USE OF THE PRODUCTS IN TERMS OF CORRECTNESS, ACCURACY, RELIABILITY, OR OTHERWISE. NI DOES NOT WARRANT THAT THE OPERATION OF THE PRODUCTS WILL BE UNINTERRUPTED OR ERROR FREE.

In the event that you and NI have a separate signed written agreement with warranty terms covering the products, then the warranty terms in the separate agreement shall control.

Copyright

Under the copyright laws, this publication may not be reproduced or transmitted in any form, electronic or mechanical, including photocopying, recording, storing in an information retrieval system, or translating, in whole or in part, without the prior written consent of National Instruments Corporation.

National Instruments respects the intellectual property of others, and we ask our users to do the same. NI software is protected by copyright and other intellectual property laws. Where NI software may be used to reproduce software or other materials belonging to others, you may use NI software only to reproduce materials that you may reproduce in accordance with the terms of any applicable license or other legal restriction.

End-User License Agreements and Third-Party Legal Notices

You can find end-user license agreements (EULAs) and third-party legal notices in the following locations:

- Notices are located in the <National Instruments>_Legal Information and <National Instruments> directories.
- EULAs are located in the <National Instruments>\Shared\MDF\Legal\license directory.
- Review <National Instruments>_Legal Information.txt for information on including legal information in installers built with NI products.

U.S. Government Restricted Rights

If you are an agency, department, or other entity of the United States Government ("Government"), the use, duplication, reproduction, release, modification, disclosure or transfer of the technical data included in this manual is governed by the Restricted Rights provisions under Federal Acquisition Regulation 52.227-14 for civilian agencies and Defense Federal Acquisition Regulation Supplement Section 252.227-7014 and 252.227-7015 for military agencies.

Trademarks

Refer to the *NI Trademarks and Logo Guidelines* at ni.com/trademarks for more information on National Instruments trademarks.

ARM, Keil, and μ Vision are trademarks or registered of ARM Ltd or its subsidiaries.

LEGO, the LEGO logo, WEDO, and MINDSTORMS are trademarks of the LEGO Group.

TETRIX by Pitsco is a trademark of Pitsco, Inc.

FIELDBUS FOUNDATION™ and FOUNDATION™ are trademarks of the Fieldbus Foundation.

EtherCAT® is a registered trademark of and licensed by Beckhoff Automation GmbH.

CANopen® is a registered Community Trademark of CAN in Automation e.V.

DeviceNet™ and EtherNet/IP™ are trademarks of ODVA.

Go!, SensorDAQ, and Vernier are registered trademarks of Vernier Software & Technology. Vernier Software & Technology and `vernier.com` are trademarks or trade dress.

Xilinx is the registered trademark of Xilinx, Inc.

Taprite and Trilobular are registered trademarks of Research Engineering & Manufacturing Inc.

FireWire® is the registered trademark of Apple Inc.

Linux® is the registered trademark of Linus Torvalds in the U.S. and other countries.

Handle Graphics®, MATLAB®, Real-Time Workshop®, Simulink®, Stateflow®, and xPC TargetBox® are registered trademarks, and TargetBox™ and Target Language Compiler™ are trademarks of The MathWorks, Inc.

Tektronix®, Tek, and Tektronix, Enabling Technology are registered trademarks of Tektronix, Inc.

The Bluetooth® word mark is a registered trademark owned by the Bluetooth SIG, Inc.

The ExpressCard™ word mark and logos are owned by PCMCIA and any use of such marks by National Instruments is under license.

The mark LabWindows is used under a license from Microsoft Corporation. Windows is a registered trademark of Microsoft Corporation in the United States and other countries.

Other product and company names mentioned herein are trademarks or trade names of their respective companies.

Members of the National Instruments Alliance Partner Program are business entities independent from National Instruments and have no agency, partnership, or joint-venture relationship with National Instruments.

Patents

For patents covering National Instruments products/technology, refer to the appropriate location: **Help»Patents** in your software, the `patents.txt` file on your media, or the *National Instruments Patent Notice* at `ni.com/patents`.

Export Compliance Information

Refer to the *Export Compliance Information* at `ni.com/legal/export-compliance` for the National Instruments global trade compliance policy and how to obtain relevant HTS codes, ECCNs, and other import/export data.

WARNING REGARDING USE OF NATIONAL INSTRUMENTS PRODUCTS

YOU ARE ULTIMATELY RESPONSIBLE FOR VERIFYING AND VALIDATING THE SUITABILITY AND RELIABILITY OF THE PRODUCTS WHENEVER THE PRODUCTS ARE INCORPORATED IN YOUR SYSTEM OR APPLICATION, INCLUDING THE APPROPRIATE DESIGN, PROCESS, AND SAFETY LEVEL OF SUCH SYSTEM OR APPLICATION.

PRODUCTS ARE NOT DESIGNED, MANUFACTURED, OR TESTED FOR USE IN LIFE OR SAFETY CRITICAL SYSTEMS, HAZARDOUS ENVIRONMENTS OR ANY OTHER ENVIRONMENTS REQUIRING FAIL-SAFE PERFORMANCE, INCLUDING IN THE OPERATION OF NUCLEAR FACILITIES; AIRCRAFT NAVIGATION; AIR TRAFFIC CONTROL SYSTEMS; LIFE SAVING OR LIFE SUSTAINING SYSTEMS OR SUCH OTHER MEDICAL DEVICES; OR ANY OTHER APPLICATION IN WHICH THE FAILURE OF THE PRODUCT OR SERVICE COULD LEAD TO DEATH, PERSONAL INJURY, SEVERE PROPERTY DAMAGE OR ENVIRONMENTAL HARM (COLLECTIVELY, "HIGH-RISK USES"). FURTHER, PRUDENT STEPS MUST BE TAKEN TO PROTECT AGAINST FAILURES, INCLUDING PROVIDING BACK-UP AND SHUT-DOWN MECHANISMS. NI EXPRESSLY DISCLAIMS ANY EXPRESS OR IMPLIED WARRANTY OF FITNESS OF THE PRODUCTS OR SERVICES FOR HIGH-RISK USES.

Contents

About This Manual

Related Documentation	ix
-----------------------------	----

Chapter 1

Getting Started

Unpacking.....	1-1
What You Need to Get Started	1-1
Key Features	1-2
Chassis Description	1-3
Optional Equipment.....	1-5
EMC Filler Panels	1-5
Rack Mount Kit	1-5
Slot Blockers.....	1-5
Replacement Power Supply.....	1-5
Replacement Fan Modules	1-5
NI PXIe-1085 Series Backplane Overview	1-5
Interoperability with CompactPCI.....	1-5
System Controller Slot.....	1-6
NI PXIe-1085 12 GB/s	1-6
NI PXIe-1085 24 GB/s	1-7
Hybrid Peripheral Slots	1-8
System Timing Slot	1-9
PXI Local Bus	1-10
PXI Trigger Bus.....	1-10
System Reference Clock.....	1-11
PXIe_SYNC_CTRL	1-13

Chapter 2

Installation and Configuration

Safety Information	2-1
Chassis Cooling Considerations	2-2
Providing Adequate Clearance	2-2
Chassis Ambient Temperature Definition	2-4
Setting Fan Speed	2-4
Considerations for High Vibration Environment	2-4
Installing Filler Panels	2-4
Installing Slot Blockers	2-4
Securing Front Panel	2-5
Rack Mounting	2-5
Connecting Safety Ground	2-6
Connecting to Power Source	2-6
Installing a PXI Express System Controller	2-7

Installing Peripheral Modules	2-8
Remote System Monitoring	2-9
Default Configuration Settings	2-10
Front Panel and Fan Module LED Indicators	2-11
Remote Voltage Monitoring and Control	2-12
Inhibit Mode Switch	2-14
PXI_CLK10 Front Panel Connectors	2-14
PXI Express System Configuration with MAX	2-15
PXI-1 System Configuration	2-15
Trigger Configuration in MAX	2-16
PXI Trigger Bus Routing	2-17
Using System Configuration and Initialization Files	2-17

Chapter 3 Maintenance

Service Interval	3-1
Preparation	3-1
Cleaning	3-1
Interior Cleaning	3-1
Exterior Cleaning	3-2
Resetting the AC Mains Circuit Breaker	3-2
Replacing the Modular Power Supply	3-3
Removal	3-3
Installation	3-5
Configuration	3-5
Connecting Safety Ground	3-6
Connecting to Power Source	3-6
Installing Replacement Fan Modules	3-6

Appendix A Specifications

Appendix B Pinouts

Appendix C Documentation Notice for MiniXML

Appendix D NI Services

Glossary

Index

About This Manual

The *NI PXIe-1085 Series User Manual* describes the features of the NI PXIe-1085 Series chassis and contains information about configuring the chassis, installing the modules, and operating the chassis.

Related Documentation

The following documents contain information that you might find helpful as you read this manual:

- IEEE 1101.1-1991, *IEEE Standard for Mechanical Core Specifications for Microcomputers Using IEC 603-2 Connectors*
- IEEE 1101.10, *IEEE Standard for Additional Mechanical Specifications for Microcomputers Using IEEE 1101.1 Equipment Practice*
- *PICMG EXP.0 R1.0 CompactPCI Express Specification*, PCI Industrial Computers Manufacturers Group
- *PCI Express Base Specification*, Revision 1.1, PCI Special Interest Group
- *PXI-5 PXI Express Hardware Specification*, Revision 2.0, PXI Systems Alliance

Getting Started

This chapter describes the key features of the NI PXIe-1085 Series chassis and lists the kit contents and optional equipment you can order from National Instruments.

Unpacking

Carefully inspect the shipping container and the chassis for damage. Check for visible damage to the metal work. Check to make sure all handles, hardware, and switches are undamaged. Inspect the inner chassis for any possible damage, debris, or detached components. If damage appears to have been caused during shipment, file a claim with the carrier. Retain the packing material for possible inspection and/or reshipment.

What You Need to Get Started

The NI PXIe-1085 Series chassis kit contains the following items:

- NI PXIe-1085 12 GB/s chassis or NI PXIe-1085 24 GB/s chassis
- Filler panels
- AC power cable—refer to Table 1-1 for AC power cables
- NI PXIe-1085 Series User Manual*
- Software media with *PXI Platform Services 3.0* or higher
- Chassis number labels
- Screw to permanently restrain the front panel
- Eight-position connector for remote voltage monitoring and control

Table 1-1. AC Power Cables

Power Cable	Reference Standards
Standard 120 V (USA)	ANSI C73.11/NEMA 5-15-P/IEC83
Switzerland 220 V	SEV
Australia 240 V	AS C112
Universal Euro 230 V	CEE (7), II, IV, VII IEC83
United Kingdom 230 V	BS 1363/IEC83

If you are missing any of the items listed in Table 1-1, or if you have the incorrect AC power cable, contact National Instruments.

Key Features

The NI PXIe-1085 Series chassis combines a high-performance 18-slot PXI Express backplane with a high-output power supply and a structural design that has been optimized for maximum usability in a wide range of applications. The chassis' modular design ensures a high level of maintainability, resulting in a very low mean time to repair (MTTR). The NI PXIe-1085 Series chassis fully complies with the *PXI-5 PXI Express Hardware Specification*, offering advanced timing and synchronization features.

The key features of the NI PXIe-1085 Series chassis include the following:

High Performance for Instrumentation Requirements

- **NI PXIe-1085 12 GB/s chassis**—Up to 4 GB/s (single direction) per PXI Express slot dedicated bandwidth (x8 Gen-2 PCI Express).
- **NI PXIe-1085 24 GB/s chassis**—Up to 8 GB/s (single direction) per PXI Express slot dedicated bandwidth (x8 Gen-3 PCI Express).
- 38.25 W per slot cooling meets increased PXI Express cooling requirements
- Low-jitter internal 10 MHz reference clock for PXI/PXI Express slots with ± 25 ppm stability
- Low-jitter internal 100 MHz reference clock for PXI Express slots with ± 25 ppm stability
- Quiet operation for 0 to 30 °C at 51.2 dBA
- Variable speed fan controller optimizes cooling and acoustic emissions
- Remote power-inhibit control
- Complies with PXI and CompactPCI Specifications

High Reliability

- 0 to 55 °C extended temperature range
- Power supply, temperature, and fan monitoring
- Field replaceable power supply and fans

Multi-Chassis Support

- PXI Express System Timing Slot for tight synchronization across chassis
- Front panel CLK10 I/O connectors
- Switchless CLK10 routing

Optional Features

- Front and rear rack-mount kits
- Replacement power supply
- EMC filler panels
- Slot blockers for improved cooling performance
- Factory installation services
- Replacement fan modules

Chassis Description

Figures 1-1 and 1-2 show the key features of the NI PXIe-1085 Series chassis front and back panels. Figure 1-1 shows the front view of the series chassis. Figure 1-2 shows the rear view of the series chassis.



Note The NI PXIe-1085 24 GB/s chassis can be identified by the blue **24 GB/s** graphic to the left of the 10 MHz REF OUT SMA connector. The NI PXIe-1085 12 GB/s chassis does not have this mark.

Figure 1-1. Front View of the NI PXIe-1085 Series Chassis

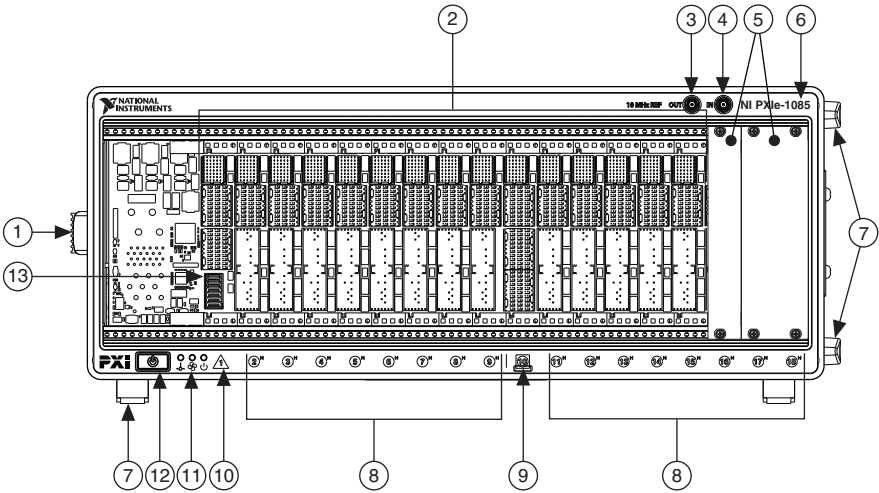

- | | |
|------------------------|---|
| 1 Chassis Carry Handle | 8 PXI Express Hybrid Peripheral Slots (16x) |
| 2 Backplane Connectors | 9 PXI Express System Timing Slot |
| 3 10 MHz REF OUT SMA | 10 PXI Express System Controller Slot |
| 4 10 MHz REF IN SMA | 11 Temperature, Fan, and Power LEDs |
| 5 PXI Filler Panels | 12 Power Inhibit Switch |
| 6 Chassis Model Name | 13 System Controller Expansion Slot |
| 7 Removable Feet | |

Figure 1-2. Rear View of the NI PXIe-1085 Series Chassis

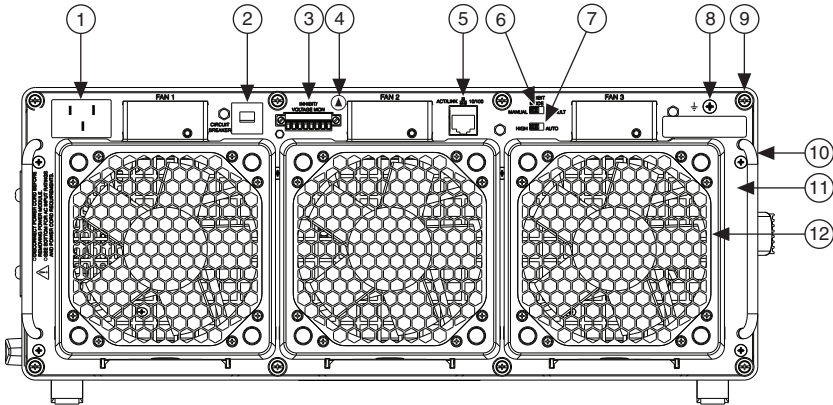

- | | |
|---|---|
| 1 Universal AC Input | 7 Fan Speed Selector Switch |
| 2 Push-Reset Circuit Breaker | 8 Chassis Ground Screw |
| 3 Remote Inhibit and Voltage Monitoring Connector | 9 Power Supply Shuttle Mounting Screws (8x) |
| 4 Electrostatic-Sensitive Device Symbol | 10 Power Supply Shuttle Handle (2x) |
| 5 Ethernet Port | 11 Power Supply Shuttle |
| 6 Inhibit Mode Selector Switch | 12 Fan Module (3x) |

Optional Equipment

Contact National Instruments to order the following options for the NI PXIe-1085 Series chassis.

EMC Filler Panels

Optional EMC filler panel kits are available from National Instruments.

Rack Mount Kit

There are two required kits for mounting the NI PXIe-1085 Series chassis into a rack. The first is a pair of mounting brackets for use on the front of the chassis. The second is a rear rack mount kit. For more information, refer to Figure A-3, *NI Chassis Rack Mount Kit Components*.

Slot Blockers

Optional PXI Slot Blocker kits are available from National Instruments for improved thermal performance when all slots are not used.

Replacement Power Supply

Optional replacement power supply kits are available from National Instruments. You easily can install replacement power supplies without the use of tools.

Replacement Fan Modules

Optional replacement fan modules are available from National Instruments. You easily can install fans in seconds without the use of tools and without powering down the system.

NI PXIe-1085 Series Backplane Overview

This section provides an overview of the backplane features for the NI PXIe-1085 Series chassis.



Note The differences between the NI PXIe-1085 12 GB/s chassis and the NI PXIe-1085 24 GB/s chassis are noted where applicable.

Interoperability with CompactPCI

The design of the NI PXIe-1085 Series chassis provides you the flexibility to use the following devices in a single PXI Express chassis:

- PXI Express compatible products
- CompactPCI Express compatible 2-Link system controller products
- CompactPCI Express compatible Type-2 peripheral products
- PXI peripheral products modified to fit in a hybrid slot
- Standard CompactPCI peripheral products modified to fit in a hybrid slot

System Controller Slot

NI PXIe-1085 12 GB/s

The system controller slot is Slot 1 of the chassis and is a 2-Link configuration system slot as defined by the CompactPCI Express and PXI Express specifications. It has three system controller expansion slots for system controller modules that are wider than one slot. These slots allow the system controller to expand to the left to prevent the system controller from using peripheral slots.

The backplane connects the system slot to two PCI Express switches using a Gen-2 x8 and a Gen-2 x16 PCI Express link. These switches distribute PCI Express connections to the peripheral slots and to two PCI Express-to-PCI bridges to provide PCI buses to the hybrid peripheral slots. Refer to Figure 1-3 for an overview of the NI PXIe-1085 Series architecture.

System slot link 1 is a Gen-2 x8 PCI Express link to PCI Express switch 1, providing a nominal bandwidth of 4 GB/s (single direction) between the system controller and PCI Express switch 1. PXI Express peripheral slots 2-10 are connected to PCI Express switch 1 with Gen-2 x8 PCI Express links and are downstream of system slot link 1. PCI Express-to-PCI bridge 1 is connected to PCI Express switch 1 and provides a 32-bit, 33 MHz PCI bus for hybrid peripheral slots 2-9.

System slot link 2 is a Gen-2 x16 PCI Express link to PCI Express switch 2, providing a nominal bandwidth of 8 GB/s (single direction) between the system controller slot and PCI Express switch 2. PXI Express peripheral slots 11-18 are connected to PCI Express switch 2 with Gen-2 x8 PCI Express links and are downstream of system slot link 2. PCI Express-to-PCI bridge 2 is connected to PCI Express switch 2 and provides a 32-bit, 33 MHz PCI bus for hybrid peripheral slots 11-18.

The system controller slot also has connectivity to some PXI features such as: PXI_CLK10, PXI Star, PXI Trigger Bus and PXI Local Bus 6.

By default, the system controller will control the power supply with the PS_ON# signals. A logic low on this line will turn the power supply on.



Note The Inhibit Mode switch on the rear of the chassis must be in the **Default** position for the system controller to have control of the power supply. Refer to the [Inhibit Mode Switch](#) section of Chapter 2, *Installation and Configuration*, for details about the Inhibit Mode switch.

NI PXIe-1085 24 GB/s

The system controller slot is Slot 1 of the chassis and is a 2-Link configuration system slot as defined by the CompactPCI Express and PXI Express specifications. It has three system controller expansion slots for system controller modules that are wider than one slot. These slots allow the system controller to expand to the left to prevent the system controller from using peripheral slots.

The backplane connects the system slot to two PCI Express switches using a Gen-3 x8 and a Gen-3 x16 PCI Express link. These switches distribute PCI Express connections to the peripheral slots and to two PCI Express-to-PCI bridges to provide PCI buses to the hybrid peripheral slots. Refer to Figure 1-3 for an overview of the NI PXIe-1085 Series architecture.

System slot link 1 is a Gen-3 x8 PCI Express link to PCI Express switch 1, providing a nominal bandwidth of 8 GB/s (single direction) between the system controller and PCI Express switch 1. PXI Express peripheral slots 2-10 are connected to PCI Express switch 1 with Gen-3 x8 PCI Express links and are downstream of system slot link 1. PCI Express-to-PCI bridge 1 is connected to PCI Express switch 1 and provides a 32-bit, 33 MHz PCI bus for hybrid peripheral slots 2-9. PCI Express switch 1 also is connected to PCI Express switch 2 with a Gen-3 x8 PCI Express link for advanced backplane configurations.

System slot link 2 is a Gen-3 x16 PCI Express link to PCI Express switch 2, providing a nominal bandwidth of 16 GB/s (single direction) between the system controller slot and PCI Express switch 2. PXI Express peripheral slots 11-18 are connected to PCI Express switch 2 with Gen-3 x8 PCI Express links and are downstream of system slot link 2. PCI Express-to-PCI bridge 2 is connected to PCI Express switch 2 and provides a 32-bit, 33 MHz PCI bus for hybrid peripheral slots 11-18. PCI Express switch 2 also is connected to PCI Express switch 1 with a Gen-3 x8 PCI Express link for advanced backplane configurations.

The system controller slot also has connectivity to some PXI features such as: PXI_CLK10, PXI Star, PXI Trigger Bus and PXI Local Bus 6.

By default, the system controller will control the power supply with the PS_ON# signals. A logic low on this line will turn the power supply on.



Note The Inhibit Mode switch on the rear of the chassis must be in the Default position for the system controller to have control of the power supply. Refer to the [Inhibit Mode Switch](#) section of Chapter 2, *Installation and Configuration*, for details about the Inhibit Mode switch.

Hybrid Peripheral Slots

The chassis provides 16 hybrid peripheral slots as defined by the *PXI-5 PXI Express Hardware Specification*: slots 2-9 and slots 11-18. A hybrid peripheral slot can accept the following peripheral modules:

- **NI PXIe-1085 12 GB/s**—A PXI Express peripheral with x8, x4, or x1 PCI Express link through a switch to the system slot. Each PXI Express peripheral slot can link up to a Gen-2 x8 PCI Express, providing a maximum nominal single-direction bandwidth of 4 GB/s.
- **NI PXIe-1085 24 GB/s**—A PXI Express peripheral with x8, x4, or x1 PCI Express link through a switch to the system slot. Each PXI Express peripheral slot can link up to a Gen-3 x8 PCI Express, providing a maximum nominal single-direction bandwidth of 8 GB/s.
- A CompactPCI Express Type-2 Peripheral with x8, x4, or x1 PCI Express link through a switch to the system slot.
- A hybrid-compatible PXI Peripheral module that has been modified by replacing the J2 connector with an XJ4 connector installed in the upper eight rows of J2. Refer to the *PXI Express Specification* for details. The PXI Peripheral communicates through the backplane’s 32-bit PCI bus.
- A CompactPCI 32-bit peripheral on the backplane’s 32-bit PCI bus.

The hybrid peripheral slots provide full PXI Express functionality and 32-bit PXI functionality except for PXI Local Bus. The hybrid peripheral slot only connects to PXI Local Bus 6 left and right.

Figure 1-3. NI PXIe-1085 12 GB/s PCI Express Backplane Diagram

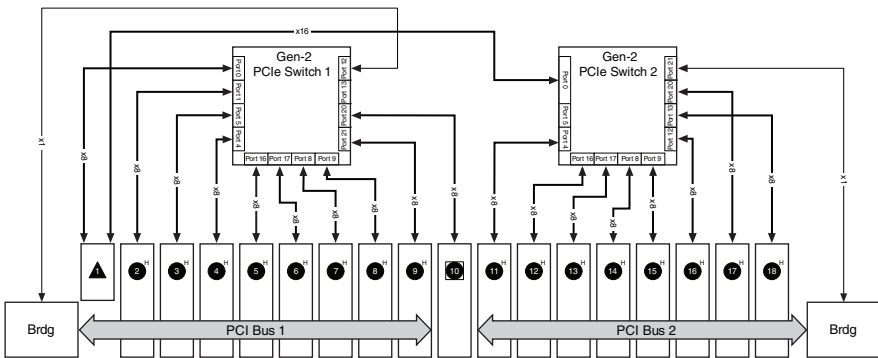
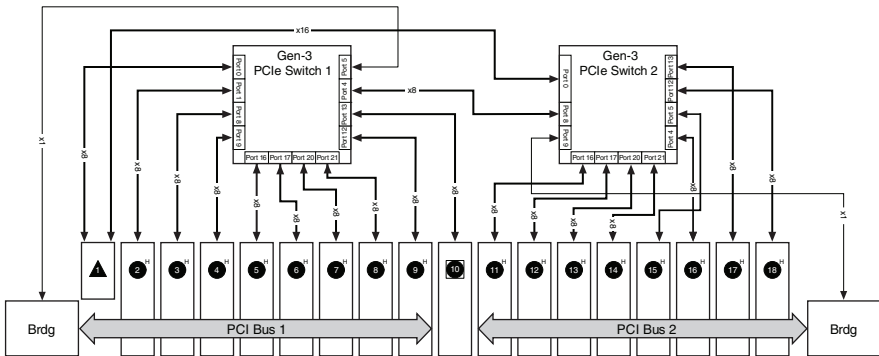

Figure 1-4. NI PXIe-1085 24 GB/s PCI Express Backplane Diagram

System Timing Slot

The System Timing Slot is slot 10. The system timing slot will accept the following peripheral modules:

- **NI PXIe-1085 12 GB/s**—A PXI Express System Timing Module with x8, x4, or x1 PCI Express link to the system slot through a PCI Express switch. Each PXI Express peripheral slot can link up to a Gen-2 x8 PCI Express, providing a maximum nominal single-direction bandwidth of 4 GB/s.
- **NI PXIe-1085 24 GB/s**—A PXI Express System Timing Module with x8, x4, or x1 PCI Express link to the system slot through a PCI Express switch. Each PXI Express peripheral slot can link up to a Gen-3 x8 PCI Express, providing a maximum nominal single-direction bandwidth of 8 GB/s.
- A PXI Express Peripheral with x8, x4, or x1 PCI Express link to the system slot through a PCI Express switch.
- A CompactPCI Express Type-2 Peripheral with x8, x4, or x1 PCI Express link to the system slot through a PCI Express switch.

The system timing slot has 3 dedicated differential pairs (PXIe_DSTAR) connected from the TP1 and TP2 connectors to the XP3 connector for each PXI Express hybrid peripheral slot, as well as routed back to the XP3 connector of the system timing slot as shown in Figure 1-5. The PXIe_DSTAR pairs can be used for high-speed triggering, synchronization and clocking. Refer to the *PXI Express Specification* for details.

The system timing slot also has a single-ended (PXI Star) trigger connected to every slot. Refer to Figure 1-5 for details.

The system timing slot has a pin (PXI_CLK10_IN) through which a system timing module may source a 10 MHz clock to which the backplane will phase-lock. Refer to the [System Reference Clock](#) section for details.

The system timing slot has a pin (PXIe_SYNC_CTRL) through which a system timing module can control the PXIe_SYNC100 timing. Refer to the *PXI Express Specification* and the *PXIe_SYNC_CTRL* section of this chapter for details.

Figure 1-5. PXI Express Star Connectivity Diagram

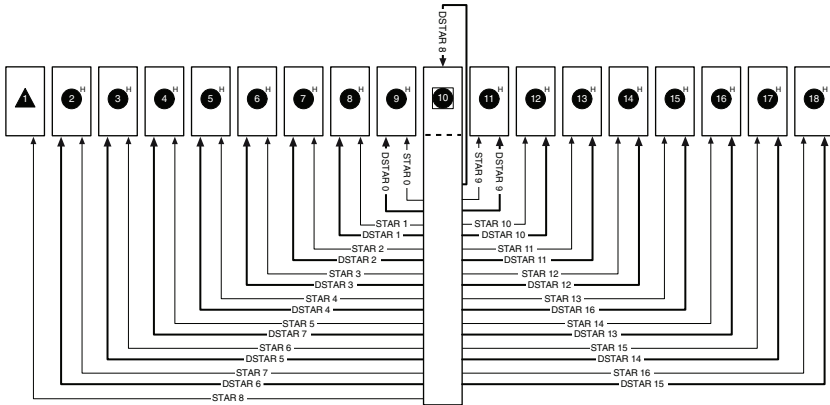

PXI Local Bus

The PXI backplane local bus is a daisy-chained bus that connects each peripheral slot with adjacent peripheral slots to the left and right, as shown in Figure 1-6.

The backplane routes PXI Local Bus 6 between all slots. The left local bus 6 from slot 1 is not routed anywhere and the right local bus signals from slot 18 are not routed anywhere.

Local bus signals may range from high-speed TTL signals to analog signals as high as 42 V.

Initialization software uses the configuration information specific to each adjacent peripheral module to evaluate local bus compatibility.

PXI Trigger Bus

All slots on the same PXI bus segment share eight PXI trigger lines. You can use these trigger lines in a variety of ways. For example, you can use triggers to synchronize the operation of several different PXI peripheral modules. In other applications, one module located in the system timing slot can control carefully timed sequences of operations performed on other modules in the system. Modules can pass triggers to one another, allowing precisely timed responses to asynchronous external events the system is monitoring or controlling.

The PXI trigger lines from adjacent PXI trigger bus segments can be routed in either direction across the PXI trigger bridges through buffers. This allows you to send trigger signals to, and receive trigger signals from, every slot in the chassis. Static trigger routing (user-specified line and directional assignments) can be configured through Measurement & Automation Explorer

(MAX). Dynamic routing of triggers (automatic line assignments) is supported through certain National Instruments drivers like NI-DAQmx.



Note Although any trigger line may be routed in either direction, it cannot be routed in more than one direction at a time.

Figure 1-6. PXI Trigger Bus Connectivity Diagram

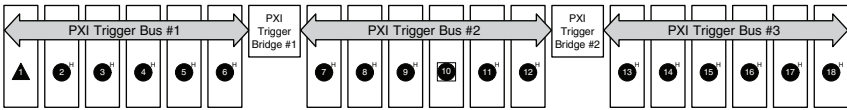

System Reference Clock

The NI PXIe-1085 Series chassis supplies PXI_CLK10, PXIe_CLK100, and PXIe_SYNC100 independently driven to each peripheral slot.

An independent buffer (having a source impedance matched to the backplane and a skew of less than 1 ns between slots) drives PXI_CLK10 to each slot. You can use this common reference clock signal to synchronize multiple modules in a measurement or control system.

An independent buffer drives PXIe_CLK100 to each peripheral slot. These clocks are matched in skew to less than 100 ps. The differential pair must be terminated on the peripheral with LVPECL termination for the buffer to drive PXIe_CLK100 so that when there is no peripheral or a peripheral that does not connect to PXIe_CLK100, there is no clock being driven on the pair to that slot.

An independent buffer drives PXIe_SYNC100 to each peripheral slot. The differential pair must be terminated on the peripheral with LVPECL termination for the buffer to drive PXIe_SYNC100 so that when there is no peripheral or a peripheral that does not connect to PXIe_SYNC100, there is no SYNC100 signal being driven on the pair to that slot.

PXI_CLK10, PXIe_CLK100 and PXIe_SYNC100 have the default timing relationship described in Figure 1-7.

Figure 1-7. System Reference Clock Default Behavior

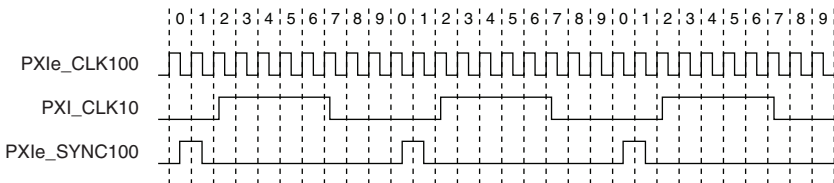

To synchronize the system to an external clock, you can drive PXI_CLK10 from an external source through the PXI_CLK10_IN pin on the System Timing Slot. Refer to Table B-8, *XP4 Connector Pinout for the System Timing Slot*, for the pinout. When a 10MHz clock is detected

on this pin, the backplane automatically phase-locks the PXI_CLK10, PXIe_CLK100, and PXIe_SYNC100 signals to this external clock and distributes these signals to the slots. Refer to Appendix A, *Specifications*, for the specification information for an external clock provided on the PXI_CLK10_IN pin of the system timing slot.

You also can drive a 10 MHz clock on the 10 MHz REF IN connector on the front panel of the chassis. When a 10 MHz clock is detected on this connector, the backplane automatically phase-locks the PXI_CLK10, PXIe_CLK100, and PXIe_SYNC100 signals to this external clock and distributes these signals to the slots. Refer to Appendix A, *Specifications*, for the specification information for an external clock provided on the 10 MHz REF IN connector on the front panel of the chassis.

If the 10 MHz clock is present on both the PXI_CLK10_IN pin of the System Timing Slot and the 10 MHz REF IN connector on the front of the chassis, the signal on the System Timing Slot is selected. Refer to Table 1-2 which explains how the 10 MHz clocks are selected by the backplane.

Table 1-2. Backplane External Clock Input Truth Table

System Timing Slot PXI_CLK10_IN	Front Chassis Panel 10 MHz REF IN	Backplane PXI_CLK10, PXIe_CLK100 and PXIe_SYNC100
No clock present	No clock present	Backplane generates its own clocks
No clock present	10 MHz clock present	PXI_CLK10, PXIe_CLK100 and PXIe_SYNC100 all phase-locked to Front Chassis Panel—10 MHz REF IN
10 MHz clock present	No clock present	PXI_CLK10, PXIe_CLK100 and PXIe_SYNC100 all phase-locked to System Timing Slot— PXI_CLK10_IN
10 MHz clock present	10 MHz clock present	PXI_CLK10, PXIe_CLK100 and PXIe_SYNC100 all phase-locked to System Timing Slot— PXI_CLK10_IN

A copy of the backplane’s PXI_CLK10 is exported to the 10 MHz REF OUT connector on the front panel of the chassis. This clock is driven by an independent buffer. Refer to Appendix A, *Specifications*, for the specification information for the 10 MHz REF OUT signal on the front panel of the chassis.

PXIe_SYNC_CTRL

PXIe_SYNC100 is by default a 10 ns pulse synchronous to PXI_CLK10. The frequency of PXIe_SYNC100 is $10/n$ MHz, where n is a positive integer. The default for n is 1, giving PXIe_SYNC100 a 100 ns period. However, the backplane allows n to be programmed to other integers. For instance, setting $n = 3$ gives a PXIe_SYNC100 with a 300 ns period while still maintaining its phase relationship to PXI_CLK10. The value for n may be set to any positive integer from 1 to 255.

The system timing slot has a control pin for PXIe_SYNC100 called PXIe_SYNC_CTRL for use when $n > 1$. Refer to Table B-7, *XP3 Connector Pinout for the System Timing Slot*, for system timing slot pinout. Refer to Appendix A, *Specifications*, for the PXIe_SYNC_CTRL input specifications.

By default, a high-level detected by the backplane on the PXIe_SYNC_CTRL pin causes a synchronous restart for the PXIe_SYNC100 signal. On the next PXI_CLK10 edge the PXIe_SYNC100 signal will restart. This will allow several chassis to have their PXIe_SYNC100 in phase with each other. Refer to Figure 1-8 for timing details with this method.

Figure 1-8. PXIe_SYNC100 at 3.33 MHz Using PXIe_SYNC_CTRL as Restart

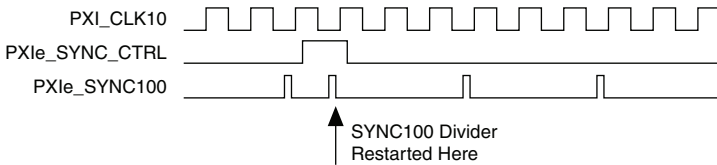

Installation and Configuration

This chapter describes how to prepare and operate the NI PXIe-1085 Series chassis.

Before connecting the chassis to a power source, read this chapter and the *Read Me First: Safety and Electromagnetic Compatibility* document included with your kit.

Safety Information



Cautions Before undertaking any troubleshooting, maintenance, or exploratory procedure, carefully read the following caution notices.

Protection equipment may be impaired if equipment is not used in the manner specified.

This equipment contains voltage hazardous to human life and safety, and is capable of inflicting personal injury.

- **Chassis Grounding**—The chassis requires a connection from the premise wire safety ground to the chassis ground. The earth safety ground must be connected during use of this equipment to minimize shock hazards. Refer to the [Connecting Safety Ground](#) section for instructions on connecting safety ground.
- **Live Circuits**—Operating personnel and service personnel *must* not remove protective covers when operating or servicing the chassis. Adjustments and service to internal components must be undertaken by qualified service technicians. During service of this product, the mains connector to the premise wiring must be disconnected. Dangerous voltages may be present under certain conditions; use extreme caution.
- **Explosive Atmosphere**—Do *not* operate the chassis in conditions where flammable gases are present. Under such conditions, this equipment is unsafe and may ignite the gases or gas fumes.
- **Part Replacement**—Only service this equipment with parts that are exact replacements, both electrically and mechanically. Contact National Instruments for replacement part information. Installation of parts with those that are not direct replacements may cause harm to personnel operating the chassis. Furthermore, damage or fire may occur if replacement parts are unsuitable.
- **Modification**—Do *not* modify any part of the chassis from its original condition. Unsuitable modifications may result in safety hazards.

Chassis Cooling Considerations

The NI PXIe-1085 Series chassis is designed to operate on a bench or in an instrument rack. The chassis must be oriented horizontally for benchtop use. Vertical orientation with the chassis handle up is not a supported configuration. Regardless of the configuration, you must provide the cooling clearances as outlined in the following sections.

Providing Adequate Clearance

The primary cooling exhaust vent for the NI PXIe-1085 Series is on the top of the chassis. The primary intake vent is on the rear of the chassis. The secondary intake and exhaust vents are located along the sides of the chassis. Adequate clearance between the chassis and surrounding equipment or blockages must be maintained to ensure proper cooling of the chassis power supply as well as the modules plugged into the chassis. These clearances are outlined in Figure 2-1. The vent locations for the NI PXIe-1085 Series chassis are shown in Figure 2-2. Failure to provide these clearances may result in thermal-related failures in the chassis or modules.

Figure 2-1. NI PXIe-1085 Series Chassis Cooling Clearances

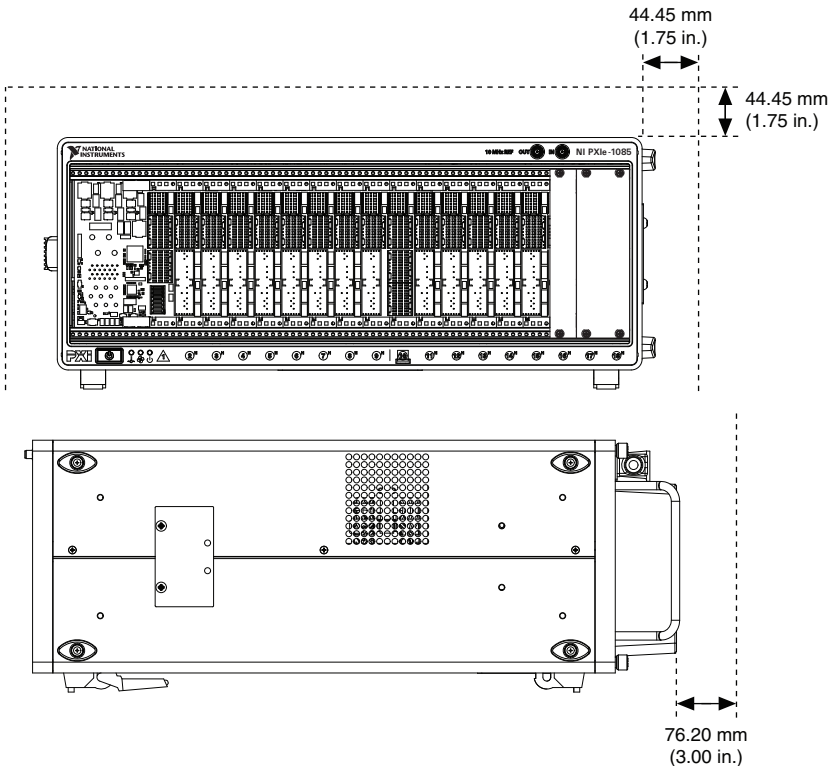
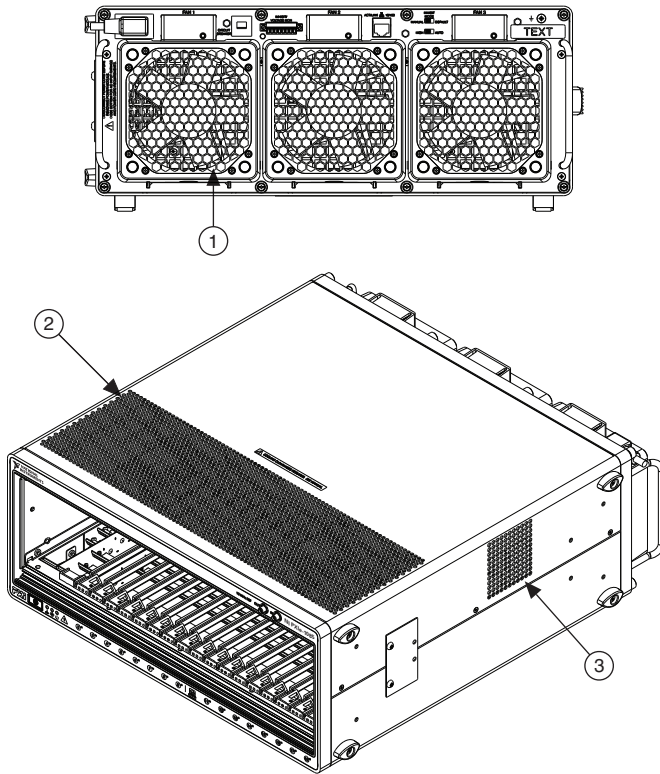

Figure 2-2. NI PXIe-1085 Series Chassis Vents



- 1 Primary Air Intake Vent (3x)
- 2 Primary Air Exhaust Vent

- 3 Secondary Air Intake/Exhaust Vents (Both Sides)

Chassis Ambient Temperature Definition

The chassis fan control system uses intake air temperature as the input for controlling fan speeds when in Auto Fan Speed mode. Because of this, the chassis ambient temperature is defined as the temperature that exists just outside of the fan intake vents on the rear of the chassis. Note that this temperature may be higher than ambient room temperature depending on the surrounding equipment and/or blockages present. It is the user's responsibility to ensure that this ambient temperature does not exceed the rated ambient temperature as stated in Appendix A, *Specifications*. If the temperature exceeds the stated spec, the temperature LED blinks red, as discussed in the *Front Panel and Fan Module LED Indicators* section of this chapter.

Setting Fan Speed

The fan-speed selector switch is on the rear panel of the NI PXIe-1085 Series chassis. Refer to Figure 1-2, *Rear View of the NI PXIe-1085 Series Chassis*, to locate the fan-speed selector switch. Select **High** for maximum cooling performance or **Auto** for improved acoustic performance. When set to **Auto**, the fan speed is determined by chassis intake air temperature.

Considerations for High Vibration Environment

For the best performance in a high vibration environment; tighten the modular power supply screws and the power supply shuttle mounting screws to 11.5 lb · in. (1.3 N · m) using a #2 Phillips screwdriver. See Figure 3-1, *Removing Power Supply Shuttle*, for screw locations.

Installing Filler Panels

To maintain proper module cooling performance, install filler panels (provided with the chassis) in unused or empty slots. Secure with the captive mounting screws provided.

Installing Slot Blockers

The cooling performance of the chassis can be improved by installing optional slot blockers. Refer to ni.com for more details.

Securing Front Panel

To permanently secure the removable front panel, use the screw in the accessory kit. Attach the screw through the bottom of the front bezel using a #2 Phillips screwdriver, as shown in Figure 2-3.

Figure 2-3. Securing Removable Front Panel

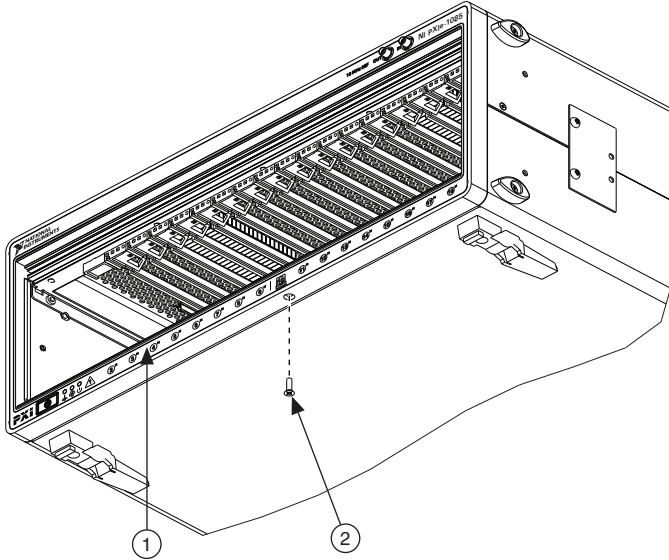

1 Removable Front Panel

2 Screw to Secure Front Panel

Rack Mounting

Rack mount applications require the optional rack mount kits available from National Instruments. Refer to the instructions supplied with the rack mount kits to install your NI PXIe-1085 Series chassis in an instrument rack. Refer to Figure A-3, [NI Chassis Rack Mount Kit Components](#).



Note You may want to remove the feet from the NI PXIe-1085 Series chassis when rack mounting. To do so, remove the screws holding the feet in place.

Connecting Safety Ground



Caution The NI PXIe-1085 Series chassis are designed with a three-position NEMA 5-15 style plug for the U.S. that connects the ground line to the chassis ground. To minimize shock hazard, make sure the electrical power outlet you use to power the chassis has an appropriate earth safety ground.

If your power outlet does not have an appropriate ground connection, you must connect the premise safety ground to the chassis grounding screw located on the rear panel. Refer to Figure 1-2, *Rear View of the NI PXIe-1085 Series Chassis*, to locate the chassis grounding screw. To connect the safety ground, complete the following steps:

1. Connect a 16 AWG (1.3 mm) wire to the chassis grounding screw using a grounding lug. The wire must have green insulation with a yellow stripe or must be noninsulated (bare).
2. Attach the opposite end of the wire to permanent earth ground using toothed washers or a toothed lug.

Connecting to Power Source



Cautions Do *not* install modules prior to performing the following power-on test.

To completely remove power, you *must* disconnect the AC power cable.

Attach input power through the rear AC inlet using the appropriate AC power cable supplied. Refer to Figure 1-2, *Rear View of the NI PXIe-1085 Series Chassis*, to locate the AC inlet.

The Inhibit Mode switch allows you to power on the chassis or place it in standby mode. Set the Inhibit Mode switch on the back of the chassis to the **Manual** position. Observe that all fans become operational and all three front panel LEDs are a steady green. Switching the Inhibit Mode switch to the **Default** position allows the system controller to control the power supply.

Installing a PXI Express System Controller

This section contains general installation instructions for installing a PXI Express system controller in a NI PXIe-1085 Series chassis. Refer to your PXI Express system controller user manual for specific instructions and warnings. To install a system controller, complete the following steps:

1. Connect the AC power source to the PXI Express chassis before installing the system controller. The AC power cord grounds the chassis and protects it from electrical damage while you install the system controller.
2. Install the system controller into the system controller slot (slot 1, indicated by the red card guides) by first placing the system controller PCB into the front of the card guides (top and bottom). Slide the system controller to the rear of the chassis, making sure that the injector/ejector handle is pushed down as shown in Figure 2-4.

Figure 2-4. Installing a PXI Express System Controller

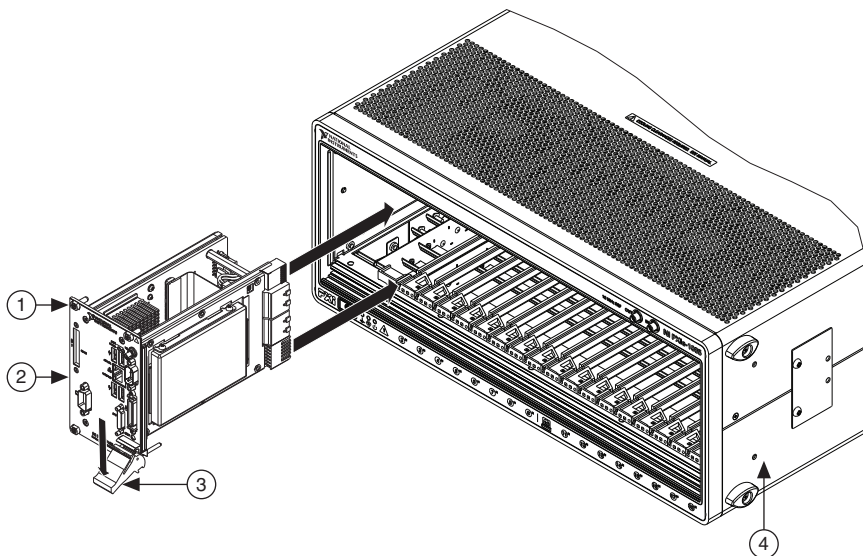

1 System Controller Front Panel Mounting Screws (4x)	3 Injector/Ejector Handle
2 NI PXI Express System Controller	4 NI PXIe-1085 Series Chassis

3. When you begin to feel resistance, pull up on the injector/ejector handle to seat the system controller fully into the chassis frame. Secure the system controller front panel to the chassis using the system controller front-panel mounting screws.
4. Connect the keyboard, mouse, and monitor to the appropriate connectors. Connect devices to ports as required by your system configuration.
5. Power on the chassis. Verify that the system controller boots. If the system controller does not boot, refer to your system controller user manual.

Figure 2-5 shows a PXI Express system controller installed in the system controller slot of a NI PXIe-1085 Series chassis. You can place CompactPCI, CompactPCI Express, PXI, or PXI Express modules in other slots depending on the slot type.

Figure 2-5. NI PXI Express System Controller Installed in a NI PXIe-1085 Series Chassis

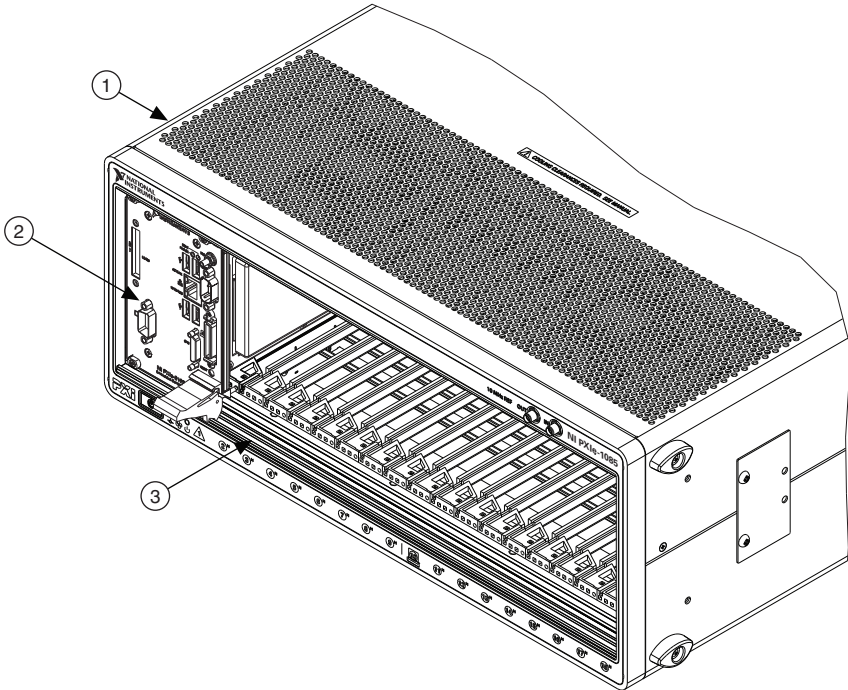

1 NI PXIe-1085 Series Chassis 2 NI PXI Express System Controller 3 Injector/Ejector Rail

Installing Peripheral Modules



Caution The NI PXIe-1085 Series chassis has been designed to accept a variety of peripheral module types in different slots. To prevent damage to the chassis, ensure that the peripheral module is being installed into a slot designed to accept it. Refer to Chapter 1, [Getting Started](#), for a description of the various slot types.

This section contains general installation instructions for installing a peripheral module in a NI PXIe-1085 Series chassis. Refer to your peripheral module user manual for specific instructions and warnings. To install a module, complete the following steps:

1. Connect the AC power source to the PXI Express chassis before installing the module. The AC power cord grounds the chassis and protects it from electrical damage while you install the module.
2. Ensure that the chassis is powered off.

3. Install a module into a chassis slot by first placing the module card PCB into the front of the card guides (top and bottom), as shown in Figure 2-6. Slide the module to the rear of the chassis, making sure that the injector/ejector handle is pushed down as shown in Figure 2-6.
4. When you begin to feel resistance, push up on the injector/ejector handle to fully seat the module into the chassis frame. Secure the module front panel to the chassis using the module front-panel mounting screws.

Figure 2-6. Installing PXI, PXI Express, or CompactPCI Peripheral Modules

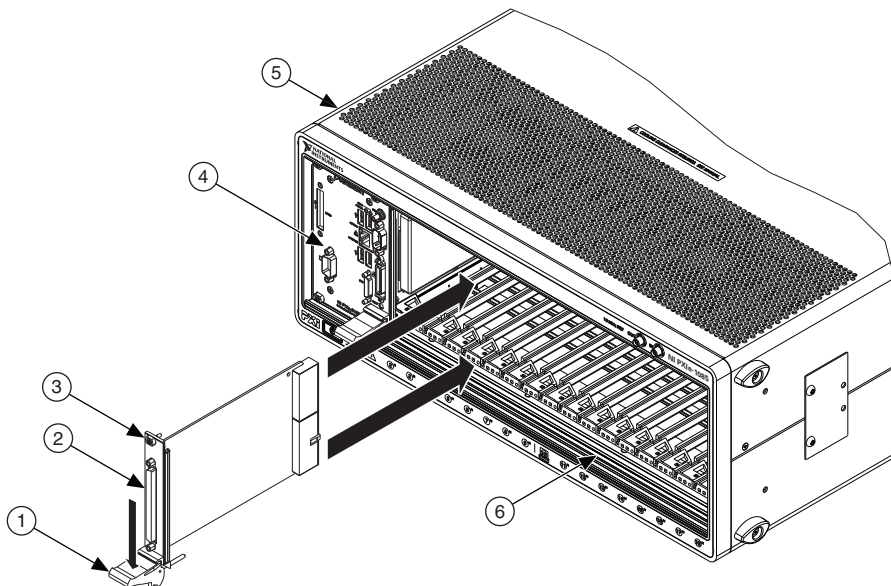

- | | | | |
|---|--|---|----------------------------------|
| 1 | Injector/Ejector Handle | 4 | NI PXI Express System Controller |
| 2 | PXI Peripheral Module | 5 | NI PXIe-1085 Series Chassis |
| 3 | Peripheral Module Front Panel Mounting Screws (2x) | 6 | Injector/Ejector Rail |

Remote System Monitoring

The NI PXIe-1085 Series chassis provides an Ethernet port on the rear panel of the chassis. You can use this Ethernet port to monitor the chassis operating parameters remotely over a network. Refer to Figure 1-2, *Rear View of the NI PXIe-1085 Series Chassis*, to locate the Ethernet connector.

The Ethernet port on the chassis supports communication speeds of 10 Mbps and 100 Mbps. Contact your network administrator to determine whether your network supports DHCP. If your network uses DHCP, the network configuration is performed automatically.

To use the remote monitoring interface, connect one end of an Ethernet cable to your NI PXIe-1085 Series chassis. Connect the other end of the cable to your Ethernet network.



Note The Ethernet controller can perform automatic crossover, thus eliminating the need for crossover cables.

Through the remote monitoring Ethernet interface of the chassis, you can access a web page with information about the current chassis operating parameters. You can access this page in most browsers. Enter the IP address or hostname currently assigned to the chassis into the browser's address bar. Figure 2-7 shows an example of the web page.

Figure 2-7. Chassis Configuration Web Page

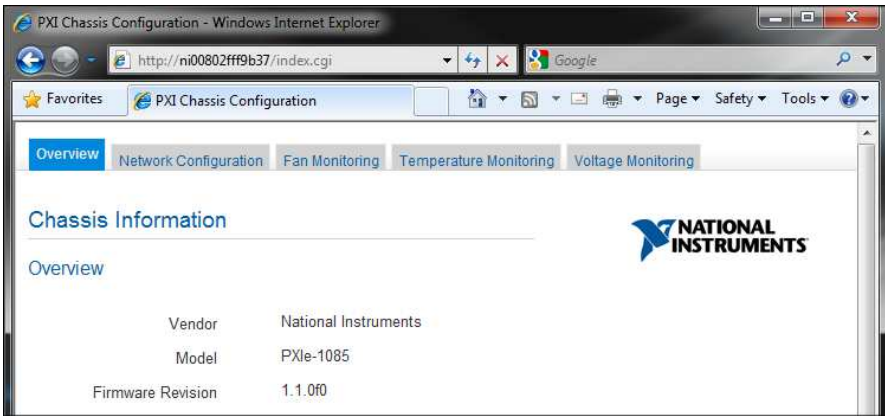

The Ethernet connector has two LEDs that indicate the current status of the Ethernet link. Table 2-1 describes the behavior of these LEDs.

Table 2-1. Ethernet LED Behavior

LED	State	Description
ACT/Link	Off	Link is not established.
	Steady green	Link is established.
	Blinking green	Chassis is communicating with another device on the network.
10/100	Off	10 Mbps data rate is selected.
	Steady green	100 Mbps data rate is selected

Default Configuration Settings

The chassis ships from the factory with the following default configuration settings:

- DHCP with Auto IP fallback
- Default hostname as printed on the product label

Front Panel and Fan Module LED Indicators

Figure 2-8 shows the front panel LEDs. Table 2-2 describes the LED states.

Figure 2-8. Front Panel LEDs

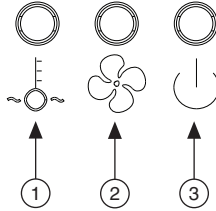

1 Temperature LED

2 Fan LED

3 Power LED

Table 2-2. Front Panel LED States

LED	State	Description
Temperature LED	Off	Chassis is powered off.
	Steady green	Intake temperature is within chassis operating range.
	Blinking red	Intake temperature is outside of chassis operating range.
	Steady red	Intake temperature has reached critical limits.
Fan LED	Off	Chassis is powered off.
	Steady green	All chassis fans are enabled and operating normally.
	Blinking red	A single chassis fan has failed, but chassis can continue to operate.
	Steady red	Two or more chassis fans have failed, and chassis must shut itself down.
Power LED	Off	Chassis is powered off.
	Steady green	Power supply is active, and all voltages are within normal operating ranges.
	Blinking red	Power supply is active, and at least one voltage is out of range.
	Steady red	Power supply has failed.

Figure 2-9 shows a fan module LED. Table 2-3 describes the LED states.

Figure 2-9. Fan Module LED

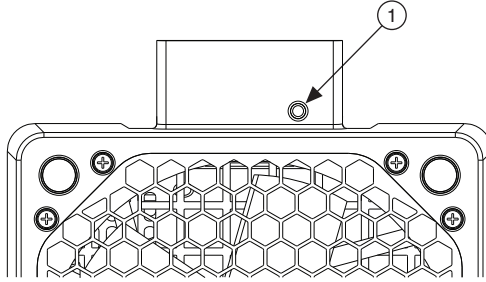

1 Fan Module LED

Table 2-3. Fan Module LED States

LED	State	Description
Fan module LED	Off	Chassis is powered off.
	Steady green	Fan is operating normally.
	Steady red	Fan has failed.



Note If two system fans or both of the power supply fans fail, the chassis shuts down automatically, preventing the chassis and modules from damage due to overheating.

Remote Voltage Monitoring and Control

The NI PXIe-1085 Series chassis supports remote voltage monitoring and inhibiting through a female 8-pin connector on the rear panel. Table 2-4 shows the pinout of the 8-pin connector.



Note The NI PXIe-1085 Series chassis accessory kit includes one 8-pin connector. To order additional connectors, use Phoenix Contact part number MC 1.5/8-STF-3.5-BK or 1847181.



Caution The Inhibit/Voltage Mon port can be damaged if subjected to Electrostatic Discharge (ESD). To prevent damage, industry-standard ESD prevention measures must be employed during installation, maintenance, and operation.

Table 2-4. Remote Inhibit and Voltage Monitoring Connector Pinout

Pin	Signal
1	Inhibit (Active Low)
2	Fault (Active High)
3	Logic Ground
4	+5 VDC
5	+3.3 VDC
6	+12 VDC
7	-12 VDC
8	Logic Ground

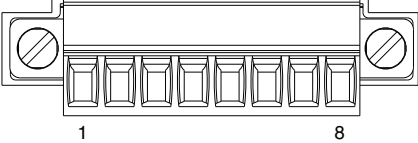

Caution When connecting digital voltmeter probes to the rear 8-pin connector, be careful not to short the probe leads together.

You can use a digital voltmeter to ensure all voltage levels in the NI PXIe-1085 Series chassis are within the allowable limits. Referring to Table 2-5, connect one lead of the voltmeter to a supply pin on the 8-pin remote voltage monitoring connector on the rear panel. Refer to Table 2-4 for a pinout diagram of the remote voltage monitoring connector. Connect the reference lead of the voltmeter to one of the ground pins. Compare each voltage reading to the values listed in Table 2-5.



Note Use the rear-panel 8-pin connector to check voltages only. Do not use the connector to supply power to external devices.

Table 2-5. Power Supply Voltages at Voltage Monitoring Connector

Pin	Supply	Acceptable Voltage Range
4	+5 V	4.75 to 5.25 V
5	+3.3 V	3.135 to 3.465 V
6	+12 V	11.4 to 12.6 V
7	-12 V	-12.6 to -11.4 V
3, 8	Logic Ground	0 V

If the voltages fall within the specified ranges, the chassis complies with the CompactPCI voltage-limit specifications.

Inhibit Mode Switch

On the rear panel of the chassis there is an Inhibit Mode switch. Refer to Figure 1-2, *Rear View of the NI PXIe-1085 Series Chassis*, for the location.

The Inhibit Mode switch should be in the **Default** position when normal power inhibit switch functionality is desired. If the user needs to power on a chassis without a system controller installed the switch should be in the **Manual** position.

When the Inhibit Mode switch is set to the **Manual** position, the power supplies are enabled, and you can use the Inhibit signal (active low) on pin 1 of the Remote Inhibit and Voltage Monitoring connector to power off the chassis. To remotely power off the chassis, connect the Inhibit pin (pin 1) to a Logic Ground pin (pin 3 or 8). As long as this connection exists, the chassis will remain off (standby); when you remove this connection, the chassis turns on.



Note For the Remote Inhibit signal to control the On/Off (standby) state of the chassis, the Inhibit Mode switch must be in the **Manual** position.

PXI_CLK10 Front Panel Connectors

There are two SMA connectors on the front of the NI PXIe-1085 Series chassis for PXI_CLK10. The connectors are labeled IN and OUT. You can use them for supplying the backplane with PXI_CLK10 or routing the backplane's PXI_CLK10 to another chassis. Refer to the *System Reference Clock* section of Chapter 1, *Getting Started*, for details about these signals.

PXI Express System Configuration with MAX

The PXI Platform Services software included with your chassis automatically identifies your PXI Express system components to generate a `pxiesys.ini` file. You can configure your entire PXI system and identify PXI-1 chassis through Measurement & Automation Explorer (MAX), included with your system controller. MAX creates the `pxiesys.ini` and `pxisys.ini` file, which define your PXI system parameters. MAX also provides an interface to route and reserve triggers so dynamic routing, through drivers such as DAQmx, avoids double-driving and potentially damaging trigger lines. For more information about routing and reserving PXI triggers, refer to KnowledgeBase 3TJDOND8 at ni.com/support.

The configuration steps for single or multiple-chassis systems are the same.

Figure 2-10. Multichassis Configuration in MAX

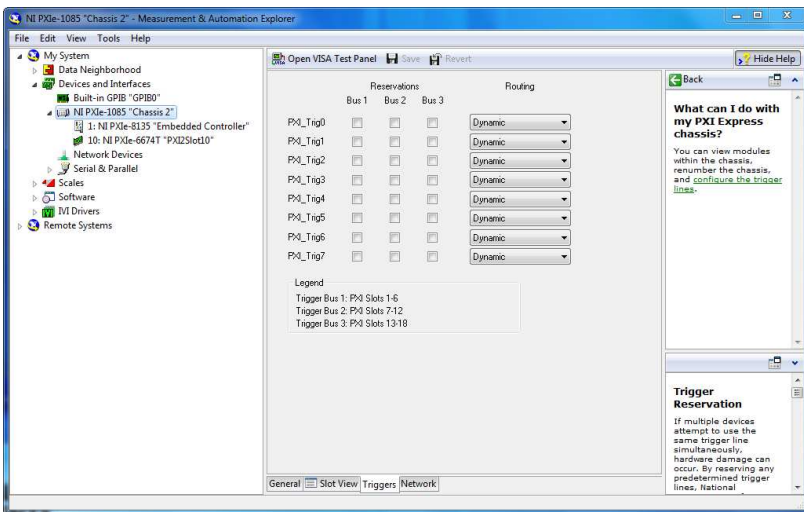

PXI-1 System Configuration

1. Launch MAX.
2. In the **Configuration** tree, click the **Devices and Interfaces** branch to expand it.
3. If the PXI system controller has not yet been configured, it is labeled **PXI System (Unidentified)**. Right-click this entry to display the pop-up menu, then select the appropriate system controller model from the **Identify As** submenu.
4. Click the PXI system controller. The chassis (or multiple chassis, in a multichassis configuration) is listed below it. Identify each chassis by right-clicking its entry, then selecting the appropriate chassis model through the **Identify As** submenu. Further expanding the **PXI System** branch shows all devices in the system that can be recognized by NI-VISA. When your system controller and all your chassis are identified, the required `pxisys.ini` file is complete.

The PXI specification allows for many combinations of PXI chassis and system modules. To assist system integrators, the manufacturers of PXI chassis and system modules must document the capabilities of their products. PXI Express devices must provide a driver and `.ini` file for identification. These files are provided as part of the PXI Platform Services software included with your system controller. The minimum documentation requirements for PXI-1 are contained in `.ini` files, which consist of ASCII text. System integrators, configuration utilities, and device drivers can use these `.ini` files.

The capability documentation for a PXI-1 chassis is contained in a `chassis.ini` file provided by the chassis manufacturer. The information in this file is combined with information about the system controller to create a single PXI-1 system initialization file called `pxisys.ini` (PXI System Initialization). The NI system controller uses MAX to generate the `pxisys.ini` file from the `chassis.ini` file.

Device drivers and other utility software read the `pxiesys.ini` and `pxisys.ini` file to obtain system information. For detailed information about initialization files, refer to the PXI specification at www.pxisa.org.

Trigger Configuration in MAX

Each chassis has one or more trigger buses, each with eight lines numbered 0 through 7 that can be reserved and routed statically or dynamically. Static reservation *pre-allocates* a trigger line to prevent its configuration by a user program. Dynamic reservation/routing/deallocation is *on the fly* within a user program based upon National Instruments APIs such as NI-DAQmx. Static reservation of trigger lines can be implemented by the user in MAX through the **Triggers** tab. Reserved trigger lines will not be used by PXI modules dynamically configured by programs such as NI-DAQmx. This prevents the instruments from double-driving the trigger lines, possibly damaging devices in the chassis. In the default configuration, trigger lines on each bus are independent. For example, if trigger line 3 is asserted on trigger bus 0, by default it will not be automatically asserted on any other trigger bus.

Complete the following steps to reserve these trigger lines in MAX.

1. In the Configuration tree, click on the PXI chassis branch you want to configure.
2. Then, in the right-hand pane, toward the bottom, click on the **Triggers** tab.
3. Select which trigger lines you would like to statically reserve.
4. Click the **Save** button.

PXI Trigger Bus Routing

Some National Instruments chassis, such as the NI PXIe-1085 Series and the NI PXI-1044/1045, have the capability to route triggers from one bus to others within the same chassis using the **Trigger Routing** tab in MAX, as shown in Figure 2-10.



Note Selecting any non-disabled routing automatically reserves the line in all trigger buses being routed to. If you are using NI-DAQmx, it will reserve and route trigger lines for you, so you won't have to route trigger lines manually.

Complete the following steps to configure trigger routings in MAX.

1. In the **Configuration** tree, select the chassis in which you want to route trigger lines.
2. In the right-hand pane, select the **Trigger Routing** tab near the bottom.
3. For each trigger line, select **Route Right**, **Route Outward From Middle**, or **Route Left** to route triggers on that line in the described direction, or select **Disabled** for the default behavior with no manual routing.
4. Click the **Apply** button.

Using System Configuration and Initialization Files

The PXI Express specification allows many combinations of PXI Express chassis and system modules. To assist system integrators, the manufacturers of PXI Express chassis and system modules must document the capabilities of their products. The minimum documentation requirements are contained in `.ini` files, which consist of ASCII text. System integrators, configuration utilities, and device drivers can use these `.ini` files.

The capability documentation for the NI PXIe-1085 Series chassis is contained in the `chassis.ini` file on the software media that comes with the chassis. The information in this file is combined with information about the system controller to create a single system initialization file called `pxisys.ini` (PXI System Initialization). The system controller manufacturer either provides a `pxisys.ini` file for the particular chassis model that contains the system controller or provides a utility that can read an arbitrary `chassis.ini` file and generate the corresponding `pxisys.ini` file. System controllers from NI provide the `pxisys.ini` file for the NI PXIe-1085 Series chassis, so you should not need to use the `chassis.ini` file. Refer to the documentation provided with the system controller or to ni.com/support for more information on `pxisys.ini` and `chassis.ini` files.

Device drivers and other utility software read the `pxisys.ini` file to obtain system information. The device drivers should have no need to directly read the `chassis.ini` file. For detailed information regarding initialization files, refer to the PXI Express specification at www.pxisa.org.

Maintenance

This chapter describes basic maintenance procedures you can perform on the NI PXIe-1085 Series chassis.



Caution Disconnect the power cable prior to servicing a NI PXIe-1085 Series chassis.

Service Interval

Clean dust from the chassis exterior (and interior) as needed, based on the operating environment. Periodic cleaning increases reliability.

Preparation

The information in this section is designed for use by qualified service personnel. Read the *Read Me First: Safety and Electromagnetic Compatibility* document included with your kit before attempting any procedures in this chapter.



Caution Many components within the chassis are susceptible to static discharge damage. Service the chassis only in a static-free environment. Observe standard handling precautions for static-sensitive devices while servicing the chassis. *Always* wear a grounded wrist strap or equivalent while servicing the chassis.

Cleaning

Cleaning procedures consist of exterior and interior cleaning of the chassis. Refer to your module user documentation for information on cleaning the individual CompactPCI or PXI Express modules.



Caution *Always* disconnect the AC power cable before cleaning or servicing the chassis.

Interior Cleaning

Use a dry, low-velocity stream of air to clean the interior of the chassis. Use a soft-bristle brush for cleaning around components.

Exterior Cleaning

Clean the exterior surfaces of the chassis with a dry lint-free cloth or a soft-bristle brush. If any dirt remains, wipe with a cloth moistened in a mild soap solution. Remove any soap residue by wiping with a cloth moistened with clear water. Do not use abrasive compounds on any part of the chassis.



Cautions Avoid getting moisture inside the chassis during exterior cleaning, especially through the top vents. Use just enough moisture to dampen the cloth.

Do *not* wash the front- or rear-panel connectors or switches. Cover these components while cleaning the chassis.

Do *not* use harsh chemical cleaning agents; they may damage the chassis. Avoid chemicals that contain benzene, toluene, xylene, acetone, or similar solvents.

Resetting the AC Mains Circuit Breaker

If the NI PXIe-1085 Series chassis is connected to an AC source and encounters an over-current condition, the circuit breaker on the rear panel will trip to prevent damage to the chassis. Complete the following steps to reset the circuit breaker.

1. Turn off the chassis.
2. Disconnect the AC power cable.
3. Depress the circuit breaker to reset it.
4. Reconnect the AC power cable.
5. Turn on the chassis.

If the circuit breaker trips again, complete the following steps:

1. Turn off the chassis.
2. Disconnect the AC power cable.
3. Remove all modules from the chassis.
4. Complete the procedure described in the [Connecting to Power Source](#) section of Chapter 2, [Installation and Configuration](#). If the power switch LED is not a steady green, contact National Instruments.
5. Verify that the NI PXIe-1085 Series chassis can meet the power requirements of your CompactPCI or PXI Express modules. Overloading the chassis can cause the breaker to trip. Refer to Appendix A, [Specifications](#).
6. The over-current condition that caused the circuit breaker to trip may be due to a faulty CompactPCI or PXI Express module. Refer to the documentation supplied with the modules for troubleshooting information.

Replacing the Modular Power Supply

This section describes how to remove, configure, and install the AC power supply shuttle in the NI PXIe-1085 Series chassis.



Caution Disconnect the power cable prior to replacing the power supply.

Before connecting the power supply shuttle to a power source, read this section and the *Read Me First: Safety and Electromagnetic Compatibility* document included with the kit.

Removal

The NI PXIe-1085 Series power supply is a replacement part for the NI PXIe-1085 Series chassis. Before attempting to replace the power supply, verify that there is adequate clearance behind the chassis. Disconnect the power cable from the power supply shuttle on the back of the chassis. Identify the eight mounting screws for the chassis that attach the power supply shuttle to the chassis. Refer to Figure 1-2, *Rear View of the NI PXIe-1085 Series Chassis*, for the screw locations. Using a Phillips screwdriver, remove the screws. Pull on the two rear handles of the power supply shuttle to remove it from the back of the chassis, as shown in Figure 3-1. About halfway through removing the shuttle, the shuttle rail safety catches engage to prevent the shuttle from falling out. Press down on the shuttle rail safety catches to remove the shuttle the rest of the way, as shown in Figure 3-1.

After removing the shuttle from the chassis, you can access the modular power supply. To remove the modular power supply, first loosen the four screws that retain it. Refer to Figure 3-1 for the screw locations. After loosening the screws, you can remove the modular power supply by rotating the handle away from the fans and pulling upward when it is in the upright position, as shown in Figure 3-2.

Figure 3-1. Removing Power Supply Shuttle

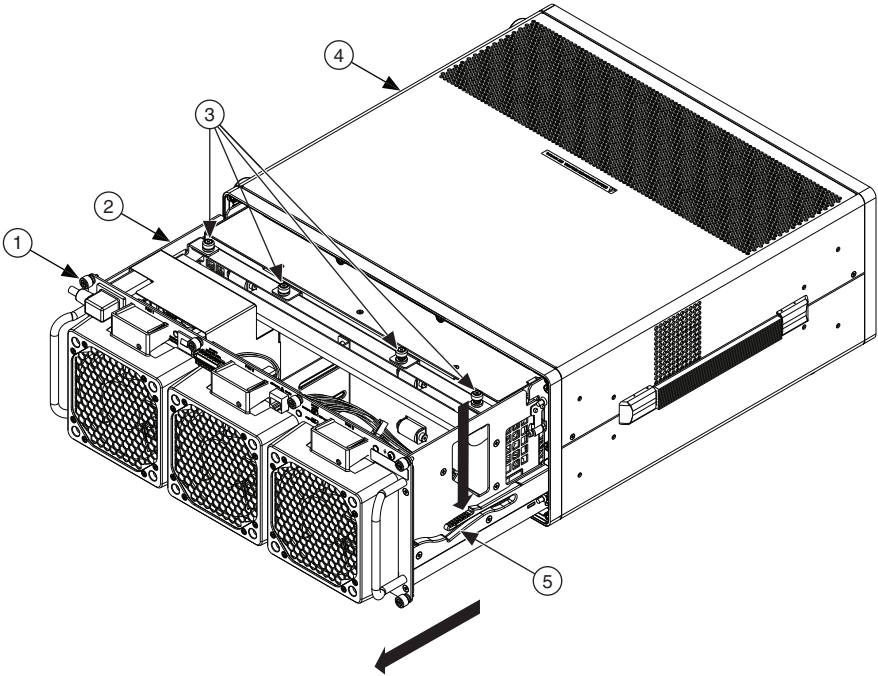

- | | |
|---|--|
| 1 Power Supply Shuttle Mounting Screws (8x) | 4 NI PXIe-1085 Series Chassis |
| 2 Power Supply Shuttle | 5 Shuttle Rail Safety Catch (Both Sides) |
| 3 Modular Power Supply Screws (4x) | |

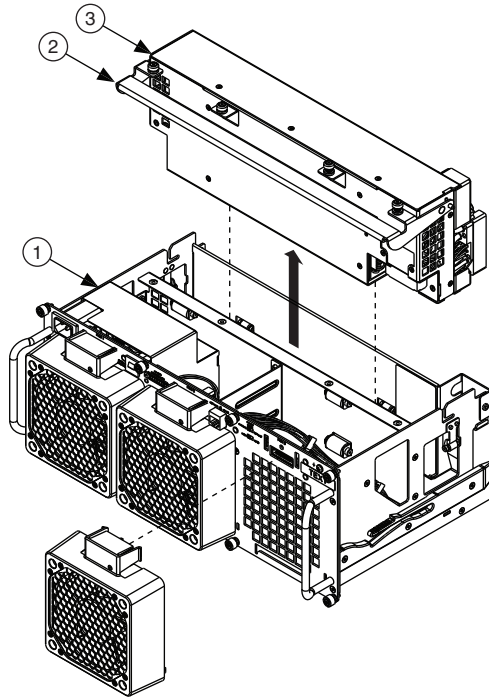
Figure 3-2. Removing Modular Power Supply from Power Supply Shuttle

1 Power Supply Shuttle 2 Modular Power Supply Handle 3 Modular Power Supply

Installation

Ensure that there is no visible damage to the new power supply assembly. Verify that the housing and connector on the new power supply assembly have no foreign material inside. Install the new power supply assembly into the opening in the shuttle in the reverse order of removal. Replace and tighten the four screws with a Phillips screwdriver or by hand.

After installing the power supply assembly, slide the power supply shuttle into the opening in the rear of the chassis. Tighten the eight screws with a Phillips screwdriver.

Configuration

The fan-speed selector switch is on the rear panel of the power supply shuttle. Refer to Figure 1-2, *Rear View of the NI PXIe-1085 Series Chassis*, to locate the fan-speed selector. Select **High** for maximum cooling performance (recommended) or **Auto** for quieter operation. Set the Inhibit Mode switch to the **Default** position.

Connecting Safety Ground

Refer to the [Connecting Safety Ground](#) section of Chapter 2, *Installation and Configuration*.

Connecting to Power Source

Refer to the [Connecting to Power Source](#) section of Chapter 2, *Installation and Configuration*.

Installing Replacement Fan Modules

Follow these steps to remove a failed fan module:

1. Pinch both snaps at the top of the fan module simultaneously.
2. Rotate the fan module downwards and remove from the chassis, as shown in Figure 3-3.

Follow these steps to install a new fan module:

1. Insert the tab that projects from the bottom of the fan module into the slot on the back of the chassis. Be sure the tab catches on the bottom of the slot.
2. Rotate the fan module upwards.
3. Pinch both snaps at the top of the fan module, rotate the module until it is flush with the chassis, and release the snaps.

Figure 3-3. Replacing Fan Module

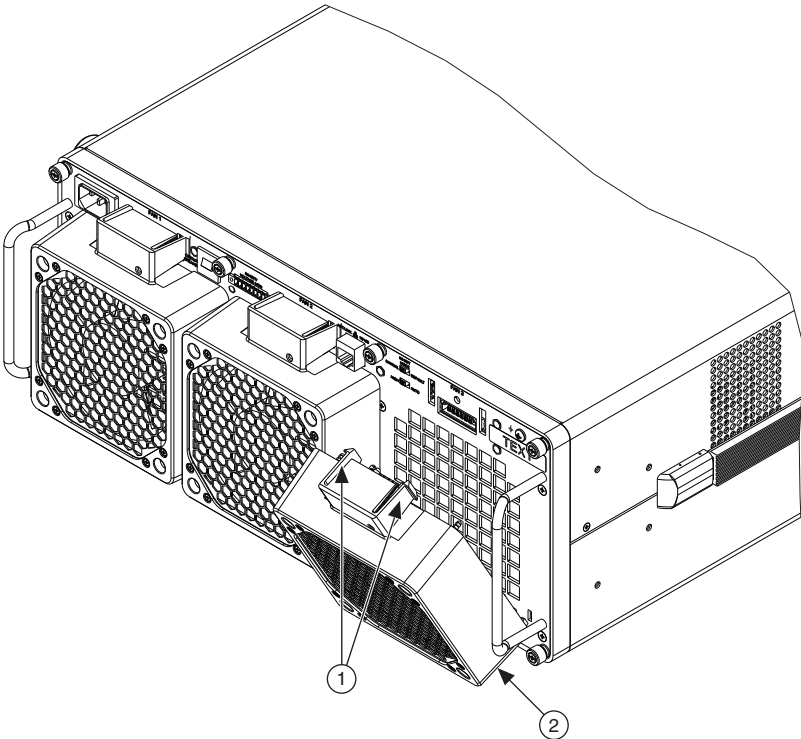

1 Fan Module Snaps

2 Fan Module

Specifications

This appendix contains specifications for the NI PXIe-1085 Series chassis.



Caution Specifications are subject to change without notice.

Electrical

AC Input

Input voltage range	100 VAC to 240 VAC
Operating voltage range ¹	90 VAC to 264 VAC
Input frequency	50 Hz/60 Hz
Operating frequency range ¹	47 Hz to 63 Hz
Input current rating	12 A to 6 A
Over-current protection	15 A circuit breaker
Line regulation	
3.3 V	<±0.2%
5 V	<±0.1%
±12 V	<±0.1%
Efficiency	70% typical
Power disconnect	The AC power cable provides main power disconnect. Do not position the equipment so that it is difficult to disconnect the power cord. The front-panel power switch causes the internal chassis power supply to provide DC power to the CompactPCI/PXI Express backplane. You also can use the rear-panel 8-pin connector and inhibit mode switch to control the internal chassis power supply.

¹ The operating range is guaranteed by design.

DC Output

DC current capacity (I_{MP})

Voltage	Maximum Current	
	NI PXIe-1085 12 GB/s	NI PXIe-1085 24 GB/s
+3.3 V	60 A	60 A
+5 V	44 A	49 A
+12 V	62 A	62 A
-12 V	4 A	4 A
5 VAUX	2 A	2 A



Note Maximum total available power for the NI PXIe-1085 12 GB/s is 791 W.

Maximum total available power for the NI PXIe-1085 24 GB/s is 775 W.

Backplane slot current capacity

Slot	+5 V	V(I/O)	+3.3 V	+12 V	-12 V	5 VAUX
System Controller Slot	15 A	—	15 A	30 A	—	1 A
System Timing Slot	—	—	6 A	4 A	—	1 A
Hybrid Peripheral Slot with PXI-1 Peripheral	6 A	5 A	6 A	1 A	1 A	—
Hybrid Peripheral Slot with PXI-5 Peripheral	—	—	6 A	4 A	—	1 A
PXI-1 Peripheral Slot	6 A	11 A	6 A	1 A	1 A	—



Notes Total system slot current should not exceed 45 A.

PCI V(I/O) pins in PXI-1 peripheral slots and hybrid peripheral slots are connected to +5 V.

The maximum power dissipated in the system slot should not exceed 140 W.

The maximum power dissipated in a peripheral slot should not exceed 38.25 W.

Load regulation

Voltage	Load Regulation
+3.3 V	<5%
+12 V	<5%
+5 V	<5%
-12 V	<5%

Maximum ripple and noise (20 MHz bandwidth)

Voltage	Maximum Ripple and Noise
+3.3 V	50 mVpp
+12 V	50 mVpp
+5 V	50 mVpp
-12 V	50 mVpp

Over-current protection All outputs protected from short circuit and overload with automatic recovery

Over-voltage protection
 3.3 V and 5 V Clamped at 20 to 30% above nominal output voltage

Power supply shuttle MTTR..... Replacement in under 5 minutes

Remote Inhibit and Voltage Monitoring Connector

Fault output signal

VOH..... 3.8 V ($I_{OH} = -8$ mA)

VOL..... 0.44 V ($I_{OH} = 8$ mA)

Inhibit input signal

VIH..... 3.5 V (min)

VIL..... 1.5 V (max)



Note Internal 10 kΩ pull-up to 5 VAUX.

Chassis Cooling

Module cooling system

NI PXIe-1085 Series chassis.....	Forced air circulation (positive pressurization) through three 169 cfm fans with High/Auto speed selector
Slot airflow direction	Bottom of module to top of module
Module cooling intake	Bottom rear of chassis
Module cooling exhaust.....	Along both sides and top of chassis
Power supply cooling system	Forced air circulation through two integrated fans
Power supply cooling intake.....	Right side of chassis
Power supply cooling exhaust	Left side of chassis

Environmental

Maximum altitude.....2,000 m (800 mbar)
(at 25 °C ambient)

Pollution Degree

For indoor use only.

Operating Environment

Ambient temperature range 0 to 55 °C
(Tested in accordance with IEC 60068-2-1 and IEC 60068-2-2. Meets MIL-PRF-28800F Class 3 low temperature limit and MIL-PRF-28800F Class 2 high temperature limit.)

Relative humidity range..... 10 to 90%, noncondensing
(Tested in accordance with IEC 60068-2-56.)

Storage Environment

Ambient temperature range -40 to 71 °C
(Tested in accordance with IEC 60068-2-1 and IEC 60068-2-2. Meets MIL-PRF-28800F Class 3 limits.)

Relative humidity range..... 5 to 95%, noncondensing
(Tested in accordance with IEC 60068-2-56.)

Shock and Vibration

Operational shock	30 g peak, half-sine, 11 ms pulse (Tested in accordance with IEC 60068-2-27. Meets MIL-PRF-28800F Class 2 limits.)
Random Vibration.....	5 to 500 Hz, 0.3 g _{rms}

Acoustic Emissions

Sound Pressure Level (at Operator Position)

(Tested in accordance with ISO 7779. Meets MIL-PRF-28800F requirements.)

Auto fan (up to ~30 °C ambient)	51.2 dBA
High fan	64.1 dBA

Sound Power

Auto fan (up to ~30 °C ambient)	60.8 dBA
High fan	75.9 dBA



Caution The protection provided by the NI PXIe-1085 Series can be impaired if it is used in a manner not described in this document.



Note Specifications are subject to change without notice.

Safety

This product is designed to meet the requirements of the following standards of safety for information technology equipment:

- IEC 61010-1, EN 61010-1
- UL 61010-1, CSA 61010-1



Note For UL and other safety certifications, refer to the product label or the [Online Product Certification](#) section.

Electromagnetic Compatibility

This product meets the requirements of the following EMC standards for electrical equipment for measurement, control, and laboratory use:

- EN 61326-1 (IEC 61326-1): Class A emissions; Basic immunity
- EN 55011 (CISPR 11): Group 1, Class A emissions
- EN 55022 (CISPR 22): Class A emissions
- EN 55024 (CISPR 24): Immunity
- AS/NZS CISPR 11: Group 1, Class A emissions

- AS/NZS CISPR 22: Class A emissions
- FCC 47 CFR Part 15B: Class A emissions
- ICES-001: Class A emissions



Note In the United States (per FCC 47 CFR), Class A equipment is intended for use in commercial, light-industrial, and heavy-industrial locations. In Europe, Canada, Australia and New Zealand (per CISPR 11) Class A equipment is intended for use only in heavy-industrial locations.



Note Group 1 equipment (per CISPR 11) is any industrial, scientific, or medical equipment that does not intentionally generate radio frequency energy for the treatment of material or inspection/analysis purposes.



Note For EMC declarations and certifications, and additional information, refer to the [Online Product Certification](#) section.

CE Compliance

This product meets the essential requirements of applicable European Directives as follows:

- 2006/95/EC; Low-Voltage Directive (safety)
- 2014/30/EU; Electromagnetic Compatibility Directive (EMC)

Online Product Certification

Refer to the product Declaration of Conformity (DoC) for additional regulatory compliance information. To obtain product certifications and the DoC for this product, visit ni.com/certification, search by model number or product line, and click the appropriate link in the Certification column.

Environmental Management

NI is committed to designing and manufacturing products in an environmentally responsible manner. NI recognizes that eliminating certain hazardous substances from our products is beneficial to the environment and to NI customers.

For additional environmental information, refer to the *Minimize Our Environmental Impact* web page at ni.com/environment. This page contains the environmental regulations and directives with which NI complies, as well as other environmental information not included in this document.

Waste Electrical and Electronic Equipment (WEEE)



EU Customers At the end of the product life cycle, all products *must* be sent to a WEEE recycling center. For more information about WEEE recycling centers, National Instruments WEEE initiatives, and compliance with WEEE Directive 2002/96/EC on Waste and Electronic Equipment, visit ni.com/environment/weee.

电子信息产品污染控制管理办法（中国 RoHS）



中国客户 National Instruments 符合中国电子信息产品中限制使用某些有害物质指令 (RoHS)。关于 National Instruments 中国 RoHS 合规性信息，请登录 ni.com/environment/rohs_china。(For information about China RoHS compliance, go to ni.com/environment/rohs_china.)

Backplane

Size	3U-sized; one system slot (with three system expansion slots) and 17 peripheral slots. Compliant with IEEE 1101.10 mechanical packaging. PXI Express Specification compliant. Accepts both PXI Express and CompactPCI (PICMG 2.0 R 3.0) 3U modules.
Backplane bare-board material	UL 94 V-0 Recognized
Backplane connectors	Conforms to IEC 917 and IEC 1076-4-101, and are UL 94 V-0 rated

System Synchronization Clocks (PXI_CLK10, PXIe_CLK100, PXIe_SYNC100)

10 MHz System Reference Clock: PXI_CLK10

Maximum slot-to-slot skew	1 ns
Accuracy	±25 ppm max. (guaranteed over the operating temperature range)
Maximum jitter	5 ps RMS phase-jitter (10 Hz to 1 MHz range)
Duty-factor	45% to 55%
Unloaded signal swing	3.3 V ±0.3 V



Note For other specifications refer to the *PXI-1 Hardware Specification*.

100 MHz System Reference Clock: PXIe_CLK100 and PXIe_SYNC100

Maximum slot-to-slot skew	100 ps
Accuracy	± 25 ppm max. (guaranteed over the operating temperature range)
Maximum jitter	3 ps RMS phase-jitter (10 Hz to 12 kHz range); 2 ps RMS phase-jitter (12 kHz to 20 MHz range)
Duty-factor for PXIe_CLK100	45% to 55%
Absolute single-ended voltage swing (When each line in the differential pair has 50 Ω termination to 1.30 V or Thévenin equivalent)	400 mV to 1000 mV



Note For other specifications refer to the *PXI-5 PXI Express Hardware Specification*.

External 10 MHz Reference Out (SMA on front panel of chassis)

Accuracy	± 25 ppm max. (guaranteed over the operating temperature range)
Maximum jitter	5 ps RMS phase-jitter (10 Hz to 1 MHz range)
Output amplitude	1 V _{PP} $\pm 20\%$ square-wave into 50 Ω 2 V _{PP} unloaded
Output impedance	50 Ω $\pm 5 \Omega$

External Clock Source

Frequency	10 MHz ± 100 PPM
Input amplitude	
Rear panel BNC	200 mV _{PP} to 5 V _{PP} square-wave or sine-wave
System timing slot PXI_CLK10_IN	5 V or 3.3 V TTL signal
Front panel SMA input impedance	50 Ω $\pm 5 \Omega$
Maximum jitter introduced by backplane	1 ps RMS phase-jitter (10 Hz to 1 MHz range)

PXIe_SYNC_CTRL

V _{IH}	2.0 V to 5.5 V
V _{IL}	0 V to 0.8 V

PXI Star Trigger

Maximum slot-to-slot skew	250 ps
Backplane characteristic impedance	65 Ω $\pm 10\%$



Notes For PXI slot to PXI Star mapping refer to the [NI PXIe-1085 24 GB/s PCI Express Backplane Diagram](#) section of Chapter 1, *Getting Started*.

For other specifications refer to the *PXI-1 Hardware Specification*.

PXI Differential Star Triggers (PXIe-DSTARA, PXIe-DSTARB, PXIe-DSTARC)

Maximum slot-to-slot skew	150 ps
Maximum differential skew	25 ps
Backplane differential impedance	100 Ω ±10%



Notes For PXI Express slot to PXI_DSTAR mapping refer to the [NI PXIe-1085 24 GB/s PCI Express Backplane Diagram](#) section of Chapter 1, *Getting Started*.

For other specifications, the NI PXIe-1085 Series chassis complies with the *PXI-5 PXI Express Hardware Specification*.

Mechanical

Overall dimensions

Standard chassis

Height	6.97 in. (177.1 mm)
Width	18.30 in. (464.8 mm)
Depth	19.38 in. (492.3 mm)



Note 0.57 in. (14.5 mm) is added to height when feet are installed. When tilted with front feet extended on table top, height is increased approximately 2.08 in. (52.8 mm) in front and 0.583 in. (14.8 mm) in rear.

Weight	40.3 lb (18.28 kg)
Chassis materials	Sheet Aluminum (5052-H32, 5754-H22), Extruded Aluminum (6063-T5, 6060-T6), Plate Aluminum (6063-T5, 6061-T6), Cold Rolled Steel, Cold Rolled Stainless Steel, Sheet Copper (C110), Santoprene, Urethane Foam, PC-ABS, Nylon, Polycarbonate, Delrin, Polyethylene, Polyamide (FR-106), Neodymium Magnet
Finish	Conductive Clear Iridite on Aluminum, Electroplated Nickel on Cold Rolled Steel, Electroplated Zinc on Cold Rolled Steel, Electroplated Nickel on Copper

Figures A-1 and A-2 show the NI PXIe-1085 Series chassis dimensions. The holes shown are for the installation of the optional rack mount kits. You can install those kits on the front or rear of the chassis, depending on which end of the chassis you want to face toward the front of the instrument cabinet. Notice that the front and rear chassis mounting holes (size M4) are symmetrical.

Figure A-1. NI PXIe-1085 Series Chassis Dimensions (Front and Side)

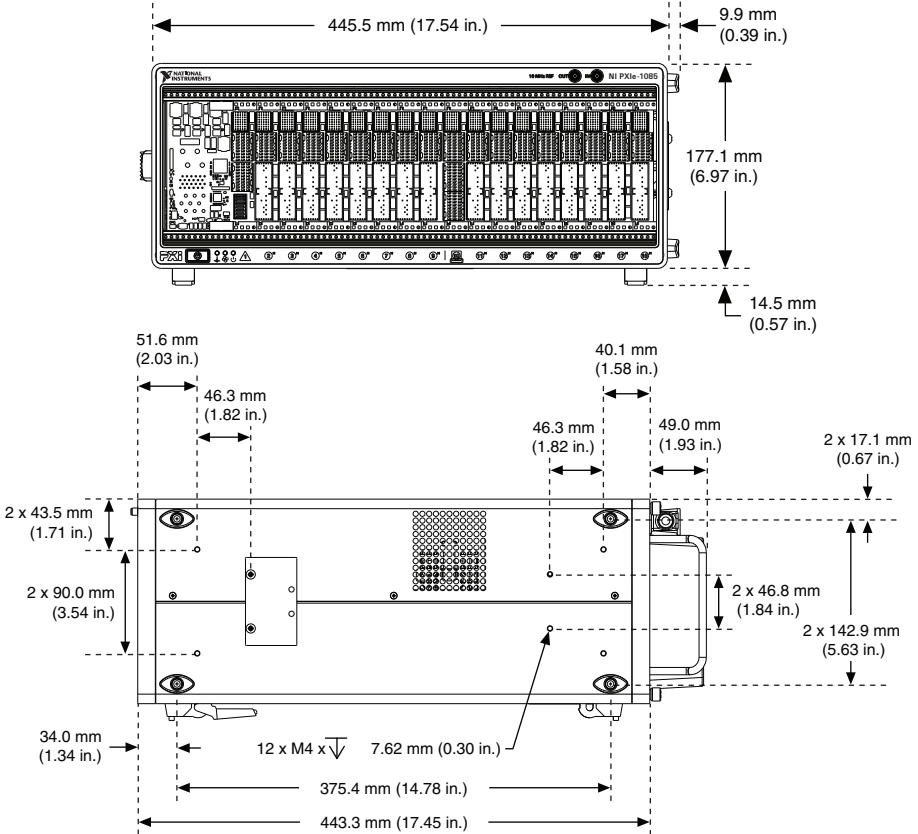

Figure A-2. NI PXIe-1085 Series Chassis Dimensions (Bottom)

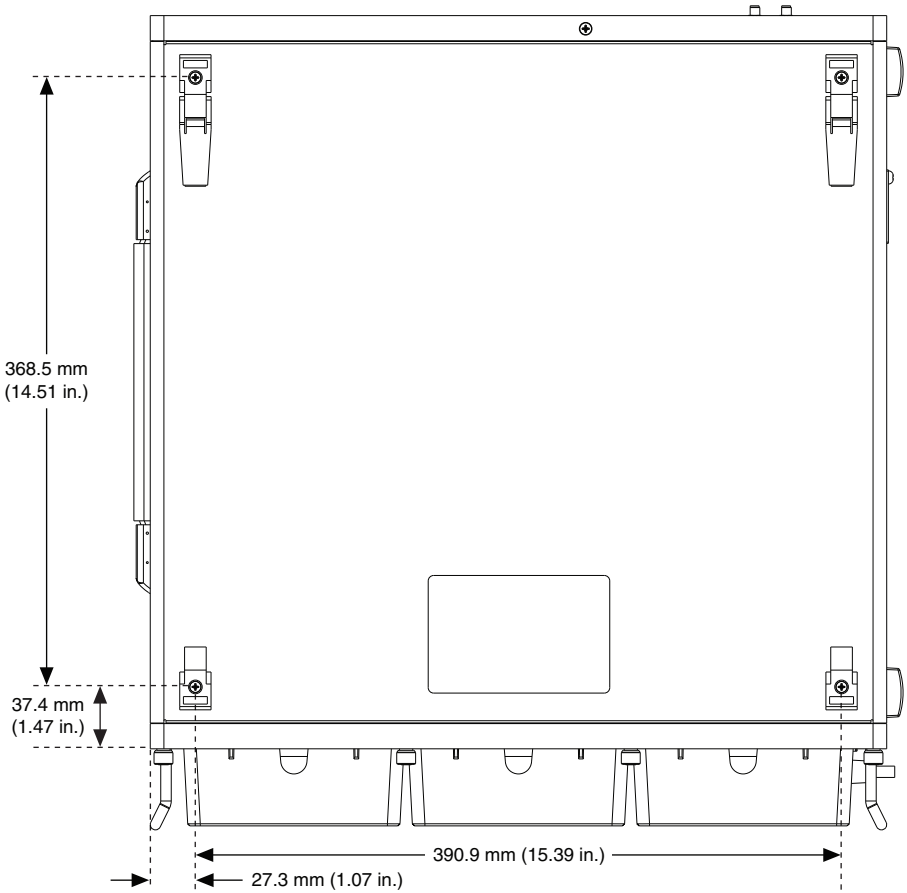
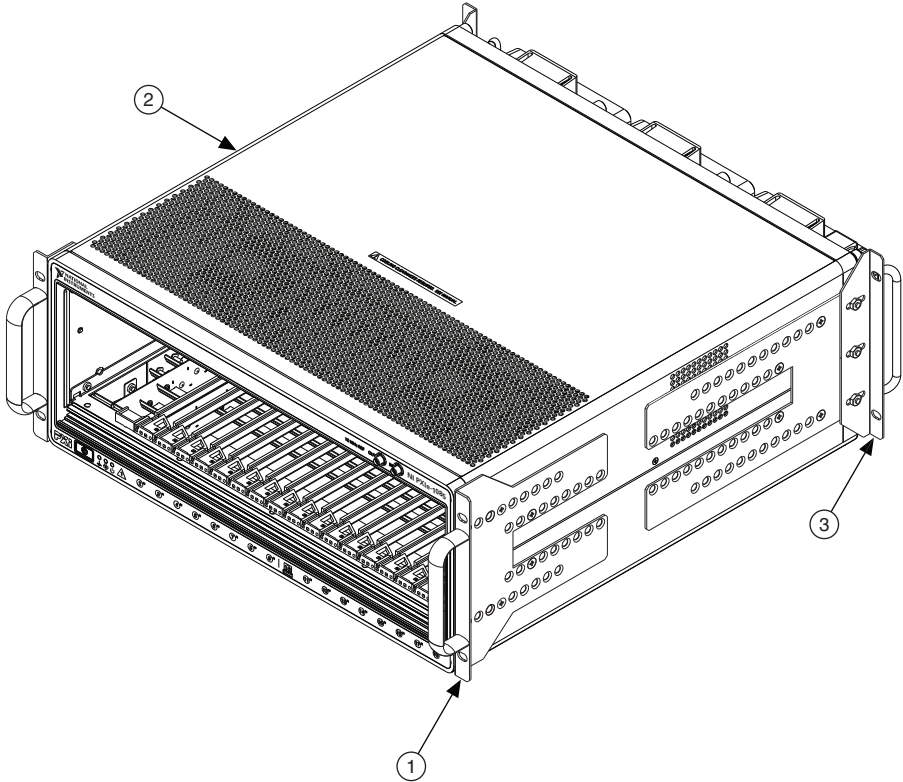

Figure A-3 shows the chassis rack mount kit components.

Figure A-3. NI Chassis Rack Mount Kit Components



1 Front Rack Mount Kit

2 NI PXIe-1085 Series Chassis

3 Rear Rack Mount Kit

Pinouts

This appendix describes the connector pinouts for the NI PXIe-1085 Series chassis backplane.

Table B-1 shows the XP1 Connector Pinout for the System Controller slot.

Table B-2 shows the XP2 Connector Pinout for the System Controller slot.

Table B-3 shows the XP3 Connector Pinout for the System Controller slot.

Table B-4 shows the XP4 Connector Pinout for the System Controller slot.

Table B-5 shows the TP1 Connector Pinout for the System Controller slot.

Table B-6 shows the TP2 Connector Pinout for the System Timing slot.

Table B-7 shows the XP3 Connector Pinout for the System Timing slot.

Table B-8 shows the XP4 Connector Pinout for the System Timing slot.

Table B-9 shows the P1 Connector Pinout for the peripheral slots.

Table B-10 shows the P2 Connector Pinout for the peripheral slots.

Table B-11 shows the P1 Connector Pinout for the Hybrid peripheral slots.

Table B-12 shows the XP3 Connector Pinout for the Hybrid peripheral slots.

Table B-13 shows the XP4 Connector Pinout for the Hybrid peripheral slots.

For more detailed information, refer to the *PXI-5 PXI Express Hardware Specification*, Revision 2.0. Contact the PXI Systems Alliance for a copy of the specification.

System Controller Slot Pinouts

Table B-1. XP1 Connector Pinout for the System Controller Slot

Pins	Signals
A	GND
B	12V
C	12V
D	GND
E	5V
F	3.3V
G	GND

Table B-2. XP2 Connector Pinout for the System Controller Slot

Pin	A	B	ab	C	D	cd	E	F	ef
1	2PETp1	2PETn1	GND	2PERp1	2PERn1	GND	2PETp2	2PETn2	GND
2	2PETp3	2PETn3	GND	2PERp3	2PERn3	GND	2PERp2	2PERn2	GND
3	2PETp4	2PETn4	GND	2PERp4	2PERn4	GND	2PETp5	2PETn5	GND
4	2PETp6	2PETn6	GND	2PERp6	2PERn6	GND	2PERp5	2PERn5	GND
5	2PETp7	2PETn7	GND	2PERp7	2PERn7	GND	2PETp8	2PETn8	GND
6	2PETp9	2PETn9	GND	2PERp9	2PERn9	GND	2PERp8	2PERn8	GND
7	2PETp10	2PETn10	GND	2PERp10	2PERn10	GND	2PETp11	2PETn11	GND
8	2PETp12	2PETn12	GND	2PERp12	2PERn12	GND	2PERp11	2PERn11	GND
9	2PETp13	2PETn13	GND	2PERp13	2PERn13	GND	2PETp14	2PETn14	GND
10	2PETp15	2PETn15	GND	2PERp15	2PERn15	GND	2PERp14	2PERn14	GND

Table B-3. XP3 Connector Pinout for the System Controller Slot

Pin	A	B	ab	C	D	cd	E	F	ef
1	RSV	RSV	GND	RSV	RSV	GND	RSV	RSV	GND
2	RSV	RSV	GND	PWR_OK	PS_ON#	GND	LINKCAP	PWRBTN#	GND
3	SMBDAT	SMBCLK	GND	RSVD	RSVD	GND	RSVD	RSVD	GND
4	RSV	PERST#	GND	2RefClk+	2RefClk-	GND	1RefClk+	1RefClk-	GND
5	1PETp0	1PETn0	GND	1PERp0	1PERn0	GND	1PETp1	1PETn1	GND
6	1PETp2	1PETn2	GND	1PERp2	1PERn2	GND	1PERp1	1PERn1	GND
7	1PETp3	1PETn3	GND	1PERp3	1PERn3	GND	1PETp4	1PETn4	GND
8	1PETp5	1PETn5	GND	1PERp5	1PERn5	GND	1PERp4	1PERn4	GND
9	1PETp6	1PETn6	GND	1PERp6	1PERn6	GND	1PETp7	1PETn7	GND
10	2PETp0	2PETn0	GND	2PERp0	2PERn0	GND	1PERp7	1PERn7	GND

Table B-4. XP4 Connector Pinout for the System Controller Slot

Pin	Z	A	B	C	D	E	F
1	GND	GA4	GA3	GA2	GA1	GA0	GND
2	GND	5Vaux	GND	SYSEN#	WAKE#	ALERT#	GND
3	GND	RSV	RSV	RSV	RSV	RSV	GND
4	GND	RSV	RSV	RSV	RSV	RSV	GND
5	GND	PXI_TRIG3	PXI_TRIG4	PXI_TRIG5	GND	PXI_TRIG6	GND
6	GND	PXI_TRIG2	GND	RSV	PXI_STAR	PXI_CLK10	GND
7	GND	PXI_TRIG1	PXI_TRIG0	RSV	GND	PXI_TRIG7	GND
8	GND	RSV	GND	RSV	RSV	PXI_LBR6	GND

System Timing Slot Pinouts

Table B-5. TP1 Connector Pinout for the System Timing Slot

Pin	A	B	ab	C	D	cd	E	F	ef
1	PXIe_DSTARA3+	PXIe_DSTARA3-	GND	PXIe_DSTARC7+	PXIe_DSTARC7-	GND	PXIe_DSTARC12+	PXIe_DSTARC12-	GND
2	PXIe_DSTARC4+	PXIe_DSTARC4-	GND	PXI_STAR12	PXI_STAR13	GND	PXIe_DSTARA12+	PXIe_DSTARA12-	GND
3	PXIe_DSTARB4+	PXIe_DSTARB4-	GND	PXIe_DSTARB16+	PXIe_DSTARA16-	GND	PXIe_DSTARB12+	PXIe_DSTARB12-	GND
4	PXIe_DSTARA4+	PXIe_DSTARA4-	GND	PXIe_DSTARB7+	PXIe_DSTARB7-	GND	PXIe_DSTARC13+	PXIe_DSTARC13-	GND
5	PXIe_DSTARC5+	PXIe_DSTARC5-	GND	PXI_STAR14	PXI_STAR15	GND	PXIe_DSTARA13+	PXIe_DSTARA13-	GND
6	PXIe_DSTARB5+	PXIe_DSTARB5-	GND	PXIe_DSTARB16+	PXIe_DSTARB16-	GND	PXIe_DSTARB13+	PXIe_DSTARB13-	GND
7	PXIe_DSTARA5+	PXIe_DSTARA5-	GND	PXIe_DSTARA7+	PXIe_DSTARA7-	GND	PXIe_DSTARC14+	PXIe_DSTARC14-	GND
8	PXIe_DSTARC6+	PXIe_DSTARC6-	GND	PXI_STAR16	RSV	GND	PXIe_DSTARA14+	PXIe_DSTARA14-	GND
9	PXIe_DSTARB6+	PXIe_DSTARB6-	GND	PXIe_DSTARC15+	PXIe_DSTARC15-	GND	PXIe_DSTARB14+	PXIe_DSTARB14-	GND
10	PXIe_DSTARA6+	PXIe_DSTARA6-	GND	PXIe_DSTARB15+	PXIe_DSTARB15-	GND	PXIe_DSTARA15+	PXIe_DSTARA15-	GND

Table B-6. TP2 Connector Pinout for the System Timing Slot

Pin	A	B	ab	C	D	cd	E	F	ef
1	PXIe_DSTARC0+	PXIe_DSTARC0-	GND	PXIe_DSTARC8+	PXIe_DSTARC8-	GND	PXIe_DSTARB8+	PXIe_DSTARB8-	GND
2	PXIe_DSTARA0+	PXIe_DSTARA0-	GND	PXIe_DSTARC9+	PXIe_DSTARC9-	GND	PXIe_DSTARA8+	PXIe_DSTARA8-	GND
3	PXIe_DSTARB0+	PXIe_DSTARB0-	GND	PXIe_DSTARC1+	PXIe_DSTARC1-	GND	PXIe_DSTARA9+	PXIe_DSTARA9-	GND
4	PXIe_DSTARB1+	PXIe_DSTARB1-	GND	PXI_STAR0	PXI_STAR1	GND	PXIe_DSTARB9+	PXIe_DSTARB9-	GND
5	PXIe_DSTARA1+	PXIe_DSTARA1-	GND	PXI_STAR2	PXI_STAR3	GND	PXIe_DSTARC10+	PXIe_DSTARC10-	GND
6	PXIe_DSTARC2+	PXIe_DSTARC2-	GND	PXI_STAR4	PXI_STAR5	GND	PXIe_DSTARA10+	PXIe_DSTARA10-	GND
7	PXIe_DSTARB2+	PXIe_DSTARB2-	GND	PXI_STAR6	PXI_STAR7	GND	PXIe_DSTARB10+	PXIe_DSTARB10-	GND
8	PXIe_DSTARA2+	PXIe_DSTARA2-	GND	PXI_STAR8	PXI_STAR9	GND	PXIe_DSTARC11+	PXIe_DSTARC11-	GND
9	PXIe_DSTARC3+	PXIe_DSTARC3-	GND	PXI_STAR10	PXI_STAR11	GND	PXIe_DSTARA11+	PXIe_DSTARA11-	GND
10	PXIe_DSTARB3+	PXIe_DSTARB3-	GND	PXIe_DSTARC16+	PXIe_DSTARC16-	GND	PXIe_DSTARB11+	PXIe_DSTARB11-	GND

Table B-7. XP3 Connector Pinout for the System Timing Slot

Pin	A	B	ab	C	D	cd	E	F	ef
1	PXIe_CLK100+	PXIe_CLK100-	GND	PXIe_SYNC100+	PXIe_SYNC100-	GND	PXIe_DSTARC+	PXIe_DSTARC-	GND
2	PRSNT#	PWREN#	GND	PXIe_DSTARB+	PXIe_DSTARB-	GND	PXIe_DSTARA+	PXIe_DSTARA-	GND
3	SMBDAT	SMBCLK	GND	RSV	RSV	GND	RSV	RSV	GND
4	MPWRGD*	PERST#	GND	RSV	RSV	GND	1RefClk+	1RefClk-	GND
5	1PETp0	1PETn0	GND	1PERp0	1PERn0	GND	1PETp1	1PETn1	GND
6	1PETp2	1PETn2	GND	1PERp2	1PERn2	GND	1PERp1	1PERn1	GND
7	1PETp3	1PETn3	GND	1PERp3	1PERn3	GND	1PETp4	1PETn4	GND
8	1PETp5	1PETn5	GND	1PERp5	1PERn5	GND	1PERp4	1PERn4	GND
9	1PETp6	1PETn6	GND	1PERp6	1PERn6	GND	1PETp7	1PETn7	GND
10	RSV	RSV	GND	RSV	RSV	GND	1PERp7	1PERn7	GND

Table B-8. XP4 Connector Pinout for the System Timing Slot

Pin	Z	A	B	C	D	E	F
1	GND	GA4	GA3	GA2	GA1	GA0	GND
2	GND	5Vaux	GND	SYSEN#	WAKE#	ALERT#	GND
3	GND	12V	12V	GND	GND	GND	GND
4	GND	GND	GND	3.3V	3.3V	3.3V	GND
5	GND	PXI_TRIG3	PXI_TRIG4	PXI_TRIG5	GND	PXI_TRIG6	GND
6	GND	PXI_TRIG2	GND	ATNLED	PXI_CLK10_IN	PXI_CLK10	GND
7	GND	PXI_TRIG1	PXI_TRIG0	ATNSW#	GND	PXI_TRIG7	GND
8	GND	PXIe_SYNC_CTRL	GND	RSV	PXI_LBL6	PXI_LBR6	GND

Peripheral Slot Pinouts

Table B-9. P1 Connector Pinout for the Peripheral Slot

Pin	Z	A	B	C	D	E	F
25	GND	5V	REQ64#	ENUM#	3.3V	5V	GND
24	GND	AD[1]	5V	V(I/O)	AD[0]	ACK64#	GND
23	GND	3.3V	AD[4]	AD[3]	5V	AD[2]	GND
22	GND	AD[7]	GND	3.3V	AD[6]	AD[5]	GND
21	GND	3.3V	AD[9]	AD[8]	M66EN	C/BE[0]#	GND
20	GND	AD[12]	GND	V(I/O)	AD[11]	AD[10]	GND
19	GND	3.3V	AD[15]	AD[14]	GND	AD[13]	GND
18	GND	SERR#	GND	3.3V	PAR	C/BE[1]#	GND
17	GND	3.3V	IPMB_SCL	IPMB_SDA	GND	PERR#	GND
16	GND	DEVSEL#	GND	V(I/O)	STOP#	LOCK#	GND
15	GND	3.3V	FRAME#	IRDY#	BD_SEL#	TRDY#	GND
12 to 14	Key Area						
11	GND	AD[18]	AD[17]	AD[16]	GND	C/BE[2]#	GND
10	GND	AD[21]	GND	3.3V	AD[20]	AD[19]	GND
9	GND	C/BE[3]#	IDSEL	AD[23]	GND	AD[22]	GND
8	GND	AD[26]	GND	V(I/O)	AD[25]	AD[24]	GND
7	GND	AD[30]	AD[29]	AD[28]	GND	AD[27]	GND
6	GND	REQ#	GND	3.3V	CLK	AD[31]	GND
5	GND	BRSVP1A5	BRSVP1B5	RST#	GND	GNT#	GND
4	GND	IPMB_PWR	HEALTHY	V(I/O)	INTP	INTS	GND

Table B-9. P1 Connector Pinout for the Peripheral Slot (Continued)

Pin	Z	A	B	C	D	E	F
3	GND	INTA#	INTB#	INTC#	5V	INTD#	GND
2	GND	TCK	5V	TMS	TDO	TDI	GND
1	GND	5V	-12V	TRST#	+12V	5V	GND

Table B-10. P2 Connector Pinout for the Peripheral Slot

Pin	Z	A	B	C	D	E	F
22	GND	GA4	GA3	GA2	GA1	GA0	GND
21	GND	PXI_LBR0	GND	PXI_LBR1	PXI_LBR2	PXI_LBR3	GND
20	GND	PXI_LBR4	PXI_LBR5	PXI_LBL0	GND	PXI_LBL1	GND
19	GND	PXI_LBL2	GND	PXI_LBL3	PXI_LBL4	PXI_LBL5	GND
18	GND	PXI_TRIG3	PXI_TRIG4	PXI_TRIG5	GND	PXI_TRIG6	GND
17	GND	PXI_TRIG2	GND	RSV	PXI_STAR	PXI_CLK10	GND
16	GND	PXI_TRIG1	PXI_TRIG0	RSV	GND	PXI_TRIG7	GND
15	GND	PXI_BRSVA15	GND	RSV	PXI_LBL6	PXI_LBR6	GND
14	GND	RSV	RSV	RSV	GND	RSV	GND
13	GND	RSV	GND	V(I/O)	RSV	RSV	GND
12	GND	RSV	RSV	RSV	GND	RSV	GND
11	GND	RSV	GND	V(I/O)	RSV	RSV	GND
10	GND	RSV	RSV	RSV	GND	RSV	GND
9	GND	RSV	GND	V(I/O)	RSV	RSV	GND
8	GND	RSV	RSV	RSV	GND	RSV	GND
7	GND	RSV	GND	V(I/O)	RSV	RSV	GND
6	GND	RSV	RSV	RSV	GND	RSV	GND
5	GND	RSV	GND	V(I/O)	RSV	RSV	GND
4	GND	V(I/O)	64EN#	RSV	GND	RSV	GND
3	GND	PXI_LBR7	GND	PXI_LBR8	PXI_LBR9	PXI_LBR10	GND
2	GND	PXI_LBR11	PXI_LBR12	UNC	PXI_LBL7	PXI_LBL8	GND
1	GND	PXI_LBL9	GND	PXI_LBL10	PXI_LBL11	PXI_LBL12	GND

Hybrid Slot Pinouts

Table B-11. P1 Connector Pinout for the Hybrid Slot

Pin	Z	A	B	C	D	E	F
25	GND	5V	REQ64#	ENUM#	3.3V	5V	GND
24	GND	AD[1]	5V	V(I/O)	AD[0]	ACK64#	GND
23	GND	3.3V	AD[4]	AD[3]	5V	AD[2]	GND
22	GND	AD[7]	GND	3.3V	AD[6]	AD[5]	GND
21	GND	3.3V	AD[9]	AD[8]	M66EN	C/BE[0]#	GND
20	GND	AD[12]	GND	V(I/O)	AD[11]	AD[10]	GND
19	GND	3.3V	AD[15]	AD[14]	GND	AD[13]	GND
18	GND	SERR#	GND	3.3V	PAR	C/BE[1]#	GND
17	GND	3.3V	IPMB_SCL	IPMB_SDA	GND	PERR#	GND
16	GND	DEVSEL#	GND	V(I/O)	STOP#	LOCK#	GND
15	GND	3.3V	FRAME#	IRDY#	BD_SEL#	TRDY#	GND
12 to 14	Key Area						
11	GND	AD[18]	AD[17]	AD[16]	GND	C/BE[2]#	GND
10	GND	AD[21]	GND	3.3V	AD[20]	AD[19]	GND
9	GND	C/BE[3]#	IDSEL	AD[23]	GND	AD[22]	GND
8	GND	AD[26]	GND	V(I/O)	AD[25]	AD[24]	GND
7	GND	AD[30]	AD[29]	AD[28]	GND	AD[27]	GND
6	GND	REQ#	GND	3.3V	CLK	AD[31]	GND
5	GND	BRSVP1A5	BRSVP1B5	RST#	GND	GNT#	GND
4	GND	IPMB_PWR	HEALTHY#	V(I/O)	INTP	INTS	GND
3	GND	INTA#	INTB#	INTC#	5V	INTD#	GND
2	GND	TCK	5V	TMS	TDO	TDI	GND
1	GND	5V	-12V	TRST#	+12V	5V	GND

Table B-12. XP3 Connector Pinout for the Hybrid Slot

Pin	A	B	ab	C	D	cd	E	F	ef
1	PXIe_CLK100+	PXIe_CLK100-	GND	PXIe_SYNC100+	PXIe_SYNC100-	GND	PXIe_DSTARC+	PXIe_DSTARC-	GND
2	PRSNT#	PWREN#	GND	PXIe_DSTARB+	PXIe_DSTARB-	GND	PXIe_DSTARA+	PXIe_DSTARA-	GND
3	SMBDAT	SMBCLK	GND	RSV	RSV	GND	RSV	RSV	GND
4	MPWRGD*	PERST#	GND	RSV	RSV	GND	1RefClk+	1RefClk-	GND
5	1PETp0	1PETn0	GND	1PERp0	1PERn0	GND	1PETp1	1PETn1	GND
6	1PETp2	1PETn2	GND	1PERp2	1PERn2	GND	1PERp1	1PERn1	GND
7	1PETp3	1PETn3	GND	1PERp3	1PERn3	GND	1PETp4	1PETn4	GND
8	1PETp5	1PETn5	GND	1PERp5	1PERn5	GND	1PERp4	1PERn4	GND
9	1PETp6	1PETn6	GND	1PERp6	1PERn6	GND	1PETp7	1PETn7	GND
10	RSV	RSV	GND	RSV	RSV	GND	1PERp7	1PERn7	GND

Table B-13. XP4 Connector Pinout for the Hybrid Slot

Pin	Z	A	B	C	D	E	F
1	GND	GA4	GA3	GA2	GA1	GA0	GND
2	GND	5Vaux	GND	SYSEN#	WAKE#	ALERT#	GND
3	GND	12V	12V	GND	GND	GND	GND
4	GND	GND	GND	3.3V	3.3V	3.3V	GND
5	GND	PXI_TRIG3	PXI_TRIG4	PXI_TRIG5	GND	PXI_TRIG6	GND
6	GND	PXI_TRIG2	GND	ATNLED	PXI_STAR	PXI_CLK10	GND
7	GND	PXI_TRIG1	PXI_TRIG0	ATNSW#	GND	PXI_TRIG7	GND
8	GND	RSV	GND	RSV	PXI_LBL6	PXI_LBR6	GND



Documentation Notice for MiniXML

This product includes code from Mini-XML 2.6 licensed by a third party or parties pursuant to the MiniXML software license, which can be found at below and that is subject to the following notice(s):

Copyright 2003–2009 by Michael Sweet

The Mini-XML library and included programs are provided under the terms of the GNU Library General Public License version 2 (LGPL2) with the following exceptions:

1. Static linking of applications to the Mini-XML library does not constitute a derivative work and does not require the author to provide source code for the application, use the shared Mini-XML libraries, or link their applications against a user-supplied version of Mini-XML.

If you link the application to a modified version of Mini-XML, then the changes to Mini-XML must be provided under the terms of the LGPL2 in sections 1, 2, and 4.

2. You do not have to provide a copy of the Mini-XML license with programs that are linked to the Mini-XML library, nor do you have to identify the Mini-XML license in your program or documentation as required by section 6 of the LGPL2.

GNU LIBRARY GENERAL PUBLIC LICENSE

Version 2, June 1991

Copyright (C) 1991 Free Software Foundation, Inc.

59 Temple Place - Suite 330, Boston, MA 02111-1307, USA

Everyone is permitted to copy and distribute verbatim copies of this license document, but changing it is not allowed.

[This is the first released version of the library GPL. It is numbered 2 because it goes with version 2 of the ordinary GPL.]

Preamble

The licenses for most software are designed to take away your freedom to share and change it. By contrast, the GNU General Public Licenses are intended to guarantee your freedom to share and change free software—to make sure the software is free for all its users.

This license, the Library General Public License, applies to some specially designated Free Software Foundation software, and to any other libraries whose authors decide to use it. You can use it for your libraries, too.

When we speak of free software, we are referring to freedom, not price. Our General Public Licenses are designed to make sure that you have the freedom to distribute copies of free software (and charge for this service if you wish), that you receive source code or can get it if you want it, that you can change the software or use pieces of it in new free programs; and that you know you can do these things.

To protect your rights, we need to make restrictions that forbid anyone to deny you these rights or to ask you to surrender the rights. These restrictions translate to certain responsibilities for you if you distribute copies of the library, or if you modify it.

For example, if you distribute copies of the library, whether gratis or for a fee, you must give the recipients all the rights that we gave you. You must make sure that they, too, receive or can get the source code. If you link a program with the library, you must provide complete object files to the recipients so that they can relink them with the library, after making changes to the library and recompiling it. And you must show them these terms so they know their rights.

Our method of protecting your rights has two steps: (1) copyright the library, and (2) offer you this license which gives you legal permission to copy, distribute and/or modify the library.

Also, for each distributor's protection, we want to make certain that everyone understands that there is no warranty for this free library. If the library is modified by someone else and passed on, we want its recipients to know that what they have is not the original version, so that any problems introduced by others will not reflect on the original authors' reputations.

Finally, any free program is threatened constantly by software patents. We wish to avoid the danger that companies distributing free software will individually obtain patent licenses, thus in effect transforming the program into proprietary software. To prevent this, we have made it clear that any patent must be licensed for everyone's free use or not licensed at all.

Most GNU software, including some libraries, is covered by the ordinary GNU General Public License, which was designed for utility programs. This license, the GNU Library General Public License, applies to certain designated libraries. This license is quite different from the ordinary one; be sure to read it in full, and don't assume that anything in it is the same as in the ordinary license.

The reason we have a separate public license for some libraries is that they blur the distinction we usually make between modifying or adding to a program and simply using it. Linking a program with a library, without changing the library, is in some sense simply using the library, and is analogous to running a utility program or application program. However, in a textual and legal sense, the linked executable is a combined work, a derivative of the original library, and the ordinary General Public License treats it as such.

Because of this blurred distinction, using the ordinary General Public License for libraries did not effectively promote software sharing, because most developers did not use the libraries. We concluded that weaker conditions might promote sharing better.

However, unrestricted linking of non-free programs would deprive the users of those programs of all benefit from the free status of the libraries themselves. This Library General Public License is intended to permit developers of non-free programs to use free libraries, while preserving your freedom as a user of such programs to change the free libraries that are incorporated in them. (We have not seen how to achieve this as regards changes in header files, but we have achieved it as regards changes in the actual functions of the Library.) The hope is that this will lead to faster development of free libraries.

The precise terms and conditions for copying, distribution and modification follow. Pay close attention to the difference between a “work based on the library” and a “work that uses the library”. The former contains code derived from the library, while the latter only works together with the library.

Note that it is possible for a library to be covered by the ordinary General Public License rather than by this special one.

TERMS AND CONDITIONS FOR COPYING, DISTRIBUTION AND MODIFICATION

0. This License Agreement applies to any software library which contains a notice placed by the copyright holder or other authorized party saying it may be distributed under the terms of this Library General Public License (also called “this License”). Each licensee is addressed as “you”.

A “library” means a collection of software functions and/or data prepared so as to be conveniently linked with application programs (which use some of those functions and data) to form executables.

The “Library”, below, refers to any such software library or work which has been distributed under these terms. A “work based on the Library” means either the Library or any derivative work under copyright law: that is to say, a work containing the Library or a portion of it, either verbatim or with modifications and/or translated straightforwardly into another language. (Hereinafter, translation is included without limitation in the term “modification”.)

“Source code” for a work means the preferred form of the work for making modifications to it. For a library, complete source code means all the source code for all modules it contains, plus any associated interface definition files, plus the scripts used to control compilation and installation of the library.

Activities other than copying, distribution and modification are not covered by this License; they are outside its scope. The act of running a program using the Library is not restricted, and output from such a program is covered only if its contents constitute a work based on the Library (independent of the use of the Library in a tool for writing it). Whether that is true depends on what the Library does and what the program that uses the Library does.

1. You may copy and distribute verbatim copies of the Library's complete source code as you receive it, in any medium, provided that you conspicuously and appropriately publish on each copy an appropriate copyright notice and disclaimer of warranty; keep intact all the notices that refer to this License and to the absence of any warranty; and distribute a copy of this License along with the Library.

You may charge a fee for the physical act of transferring a copy, and you may at your option offer warranty protection in exchange for a fee.

2. You may modify your copy or copies of the Library or any portion of it, thus forming a work based on the Library, and copy and distribute such modifications or work under the terms of Section 1 above, provided that you also meet all of these conditions:
 - a. The modified work must itself be a software library.
 - b. You must cause the files modified to carry prominent notices stating that you changed the files and the date of any change.
 - c. You must cause the whole of the work to be licensed at no charge to all third parties under the terms of this License.
 - d. If a facility in the modified Library refers to a function or a table of data to be supplied by an application program that uses the facility, other than as an argument passed when the facility is invoked, then you must make a good faith effort to ensure that, in the event an application does not supply such function or table, the facility still operates, and performs whatever part of its purpose remains meaningful.

(For example, a function in a library to compute square roots has a purpose that is entirely well-defined independent of the application. Therefore, Subsection 2d requires that any application-supplied function or table used by this function must be optional: if the application does not supply it, the square root function must still compute square roots.)

These requirements apply to the modified work as a whole. If identifiable sections of that work are not derived from the Library, and can be reasonably considered independent and separate works in themselves, then this License, and its terms, do not apply to those sections when you distribute them as separate works. But when you distribute the same sections as part of a whole which is a work based on the Library, the distribution of the whole must be on the terms of this License, whose permissions for other licensees extend to the entire whole, and thus to each and every part regardless of who wrote it.

Thus, it is not the intent of this section to claim rights or contest your rights to work written entirely by you; rather, the intent is to exercise the right to control the distribution of derivative or collective works based on the Library.

In addition, mere aggregation of another work not based on the Library with the Library (or with a work based on the Library) on a volume of a storage or distribution medium does not bring the other work under the scope of this License.

3. You may opt to apply the terms of the ordinary GNU General Public License instead of this License to a given copy of the Library. To do this, you must alter all the notices that refer to this License, so that they refer to the ordinary GNU General Public License, version 2, instead of to this License. (If a newer version than version 2 of the ordinary GNU General

Public License has appeared, then you can specify that version instead if you wish.) Do not make any other change in these notices.

Once this change is made in a given copy, it is irreversible for that copy, so the ordinary GNU General Public License applies to all subsequent copies and derivative works made from that copy.

This option is useful when you wish to copy part of the code of the Library into a program that is not a library.

4. You may copy and distribute the Library (or a portion or derivative of it, under Section 2) in object code or executable form under the terms of Sections 1 and 2 above provided that you accompany it with the complete corresponding machine-readable source code, which must be distributed under the terms of Sections 1 and 2 above on a medium customarily used for software interchange.

If distribution of object code is made by offering access to copy from a designated place, then offering equivalent access to copy the source code from the same place satisfies the requirement to distribute the source code, even though third parties are not compelled to copy the source along with the object code.

5. A program that contains no derivative of any portion of the Library, but is designed to work with the Library by being compiled or linked with it, is called a “work that uses the Library”. Such a work, in isolation, is not a derivative work of the Library, and therefore falls outside the scope of this License.

However, linking a “work that uses the Library” with the Library creates an executable that is a derivative of the Library (because it contains portions of the Library), rather than a “work that uses the library”. The executable is therefore covered by this License. Section 6 states terms for distribution of such executables.

When a “work that uses the Library” uses material from a header file that is part of the Library, the object code for the work may be a derivative work of the Library even though the source code is not. Whether this is true is especially significant if the work can be linked without the Library, or if the work is itself a library. The threshold for this to be true is not precisely defined by law.

If such an object file uses only numerical parameters, data structure layouts and accessors, and small macros and small inline functions (ten lines or less in length), then the use of the object file is unrestricted, regardless of whether it is legally a derivative work. (Executables containing this object code plus portions of the Library will still fall under Section 6.)

Otherwise, if the work is a derivative of the Library, you may distribute the object code for the work under the terms of Section 6. Any executables containing that work also fall under Section 6, whether or not they are linked directly with the Library itself.

6. As an exception to the Sections above, you may also compile or link a “work that uses the Library” with the Library to produce a work containing portions of the Library, and distribute that work under terms of your choice, provided that the terms permit modification of the work for the customer's own use and reverse engineering for debugging such modifications.

You must give prominent notice with each copy of the work that the Library is used in it and that the Library and its use are covered by this License. You must supply a copy of this License. If the work during execution displays copyright notices, you must include the copyright notice for the Library among them, as well as a reference directing the user to the copy of this License. Also, you must do one of these things:

- a. Accompany the work with the complete corresponding machine-readable source code for the Library including whatever changes were used in the work (which must be distributed under Sections 1 and 2 above); and, if the work is an executable linked with the Library, with the complete machine-readable “work that uses the Library”, as object code and/or source code, so that the user can modify the Library and then relink to produce a modified executable containing the modified Library. (It is understood that the user who changes the contents of definitions files in the Library will not necessarily be able to recompile the application to use the modified definitions.)
- b. Accompany the work with a written offer, valid for at least three years, to give the same user the materials specified in Subsection 6a, above, for a charge no more than the cost of performing this distribution.
- c. If distribution of the work is made by offering access to copy from a designated place, offer equivalent access to copy the above specified materials from the same place.
- d. Verify that the user has already received a copy of these materials or that you have already sent this user a copy.

For an executable, the required form of the “work that uses the Library” must include any data and utility programs needed for reproducing the executable from it. However, as a special exception, the source code distributed need not include anything that is normally distributed (in either source or binary form) with the major components (compiler, kernel, and so on) of the operating system on which the executable runs, unless that component itself accompanies the executable.

It may happen that this requirement contradicts the license restrictions of other proprietary libraries that do not normally accompany the operating system. Such a contradiction means you cannot use both them and the Library together in an executable that you distribute.

7. You may place library facilities that are a work based on the Library side-by-side in a single library together with other library facilities not covered by this License, and distribute such a combined library, provided that the separate distribution of the work based on the Library and of the other library facilities is otherwise permitted, and provided that you do these two things:
 - a. Accompany the combined library with a copy of the same work based on the Library, uncombined with any other library facilities. This must be distributed under the terms of the Sections above.
 - b. Give prominent notice with the combined library of the fact that part of it is a work based on the Library, and explaining where to find the accompanying uncombined form of the same work.

8. You may not copy, modify, sublicense, link with, or distribute the Library except as expressly provided under this License. Any attempt otherwise to copy, modify, sublicense, link with, or distribute the Library is void, and will automatically terminate your rights under this License. However, parties who have received copies, or rights, from you under this License will not have their licenses terminated so long as such parties remain in full compliance.
9. You are not required to accept this License, since you have not signed it. However, nothing else grants you permission to modify or distribute the Library or its derivative works. These actions are prohibited by law if you do not accept this License. Therefore, by modifying or distributing the Library (or any work based on the Library), you indicate your acceptance of this License to do so, and all its terms and conditions for copying, distributing or modifying the Library or works based on it.
10. Each time you redistribute the Library (or any work based on the Library), the recipient automatically receives a license from the original licensor to copy, distribute, link with or modify the Library subject to these terms and conditions. You may not impose any further restrictions on the recipients' exercise of the rights granted herein. You are not responsible for enforcing compliance by third parties to this License.
11. If, as a consequence of a court judgment or allegation of patent infringement or for any other reason (not limited to patent issues), conditions are imposed on you (whether by court order, agreement or otherwise) that contradict the conditions of this License, they do not excuse you from the conditions of this License. If you cannot distribute so as to satisfy simultaneously your obligations under this License and any other pertinent obligations, then as a consequence you may not distribute the Library at all. For example, if a patent license would not permit royalty-free redistribution of the Library by all those who receive copies directly or indirectly through you, then the only way you could satisfy both it and this License would be to refrain entirely from distribution of the Library.

If any portion of this section is held invalid or unenforceable under any particular circumstance, the balance of the section is intended to apply, and the section as a whole is intended to apply in other circumstances.

It is not the purpose of this section to induce you to infringe any patents or other property right claims or to contest validity of any such claims; this section has the sole purpose of protecting the integrity of the free software distribution system which is implemented by public license practices. Many people have made generous contributions to the wide range of software distributed through that system in reliance on consistent application of that system; it is up to the author/donor to decide if he or she is willing to distribute software through any other system and a licensee cannot impose that choice.

This section is intended to make thoroughly clear what is believed to be a consequence of the rest of this License.

12. If the distribution and/or use of the Library is restricted in certain countries either by patents or by copyrighted interfaces, the original copyright holder who places the Library under this License may add an explicit geographical distribution limitation excluding those countries, so that distribution is permitted only in or among countries not thus excluded. In such case, this License incorporates the limitation as if written in the body of this License.

13. The Free Software Foundation may publish revised and/or new versions of the Library General Public License from time to time. Such new versions will be similar in spirit to the present version, but may differ in detail to address new problems or concerns.

Each version is given a distinguishing version number. If the Library specifies a version number of this License which applies to it and “any later version”, you have the option of following the terms and conditions either of that version or of any later version published by the Free Software Foundation. If the Library does not specify a license version number, you may choose any version ever published by the Free Software Foundation.

14. If you wish to incorporate parts of the Library into other free programs whose distribution conditions are incompatible with these, write to the author to ask for permission. For software which is copyrighted by the Free Software Foundation, write to the Free Software Foundation; we sometimes make exceptions for this. Our decision will be guided by the two goals of preserving the free status of all derivatives of our free software and of promoting the sharing and reuse of software generally.

NO WARRANTY

15. BECAUSE THE LIBRARY IS LICENSED FREE OF CHARGE, THERE IS NO WARRANTY FOR THE LIBRARY, TO THE EXTENT PERMITTED BY APPLICABLE LAW. EXCEPT WHEN OTHERWISE STATED IN WRITING THE COPYRIGHT HOLDERS AND/OR OTHER PARTIES PROVIDE THE LIBRARY “AS IS” WITHOUT WARRANTY OF ANY KIND, EITHER EXPRESSED OR IMPLIED, INCLUDING, BUT NOT LIMITED TO, THE IMPLIED WARRANTIES OF MERCHANTABILITY AND FITNESS FOR A PARTICULAR PURPOSE. THE ENTIRE RISK AS TO THE QUALITY AND PERFORMANCE OF THE LIBRARY IS WITH YOU. SHOULD THE LIBRARY PROVE DEFECTIVE, YOU ASSUME THE COST OF ALL NECESSARY SERVICING, REPAIR OR CORRECTION.
16. IN NO EVENT UNLESS REQUIRED BY APPLICABLE LAW OR AGREED TO IN WRITING WILL ANY COPYRIGHT HOLDER, OR ANY OTHER PARTY WHO MAY MODIFY AND/OR REDISTRIBUTE THE LIBRARY AS PERMITTED ABOVE, BE LIABLE TO YOU FOR DAMAGES, INCLUDING ANY GENERAL, SPECIAL, INCIDENTAL OR CONSEQUENTIAL DAMAGES ARISING OUT OF THE USE OR INABILITY TO USE THE LIBRARY (INCLUDING BUT NOT LIMITED TO LOSS OF DATA OR DATA BEING RENDERED INACCURATE OR LOSSES SUSTAINED BY YOU OR THIRD PARTIES OR A FAILURE OF THE LIBRARY TO OPERATE WITH ANY OTHER SOFTWARE), EVEN IF SUCH HOLDER OR OTHER PARTY HAS BEEN ADVISED OF THE POSSIBILITY OF SUCH DAMAGES.

END OF TERMS AND CONDITIONS

How to Apply These Terms to Your New Libraries

If you develop a new library, and you want it to be of the greatest possible use to the public, we recommend making it free software that everyone can redistribute and change. You can do so by permitting redistribution under these terms (or, alternatively, under the terms of the ordinary General Public License).

To apply these terms, attach the following notices to the library. It is safest to attach them to the start of each source file to most effectively convey the exclusion of warranty; and each file should have at least the “copyright” line and a pointer to where the full notice is found.

```
<one line to give the library's name and an idea of what it does. >
Copyright (C) <year> <name of author>
```

This library is free software; you can redistribute it and/or modify it under the terms of the GNU Lesser General Public License as published by the Free Software Foundation; either version 2.1 of the License, or (at your option) any later version.

This library is distributed in the hope that it will be useful, but WITHOUT ANY WARRANTY; without even the implied warranty of MERCHANTABILITY or FITNESS FOR A PARTICULAR PURPOSE. See the GNU Lesser General Public License for more details.

You should have received a copy of the GNU Lesser General Public License along with this library; if not, write to the Free Software Foundation, Inc., 59 Temple Place, Suite 330, Boston, MA 02111-1307 USA

Also add information on how to contact you by electronic and paper mail.

You should also get your employer (if you work as a programmer) or your school, if any, to sign a “copyright disclaimer” for the library, if necessary. Here is a sample; alter the names:

Yoyodyne, Inc., hereby disclaims all copyright interest in the library ‘Frob’ (a library for tweaking knobs) written by James Random Hacker.

signature of Ty Coon, 1 April 1990 Ty Coon, President of Vice

That’s all there is to it!

NI Services

National Instruments provides global services and support as part of our commitment to your success. Take advantage of product services in addition to training and certification programs that meet your needs during each phase of the application life cycle; from planning and development through deployment and ongoing maintenance.

To get started, register your product at ni.com/myproducts.

As a registered NI product user, you are entitled to the following benefits:

- Access to applicable product services.
- Easier product management with an online account.
- Receive critical part notifications, software updates, and service expirations.

Log in to your National Instruments ni.com User Profile to get personalized access to your services.

Services and Resources

- **Maintenance and Hardware Services**—NI helps you identify your systems' accuracy and reliability requirements and provides warranty, sparing, and calibration services to help you maintain accuracy and minimize downtime over the life of your system. Visit ni.com/services for more information.
 - **Warranty and Repair**—All NI hardware features a one-year standard warranty that is extendable up to five years. NI offers repair services performed in a timely manner by highly trained factory technicians using only original parts at a National Instruments service center.
 - **Calibration**—Through regular calibration, you can quantify and improve the measurement performance of an instrument. NI provides state-of-the-art calibration services. If your product supports calibration, you can obtain the calibration certificate for your product at ni.com/calibration.
- **System Integration**—If you have time constraints, limited in-house technical resources, or other project challenges, National Instruments Alliance Partner members can help. To learn more, call your local NI office or visit ni.com/alliance.

- **Training and Certification**—The NI training and certification program is the most effective way to increase application development proficiency and productivity. Visit ni.com/training for more information.
 - The Skills Guide assists you in identifying the proficiency requirements of your current application and gives you options for obtaining those skills consistent with your time and budget constraints and personal learning preferences. Visit ni.com/skills-guide to see these custom paths.
 - NI offers courses in several languages and formats including instructor-led classes at facilities worldwide, courses on-site at your facility, and online courses to serve your individual needs.
- **Technical Support**—Support at ni.com/support includes the following resources:
 - **Self-Help Technical Resources**—Visit ni.com/support for software drivers and updates, a searchable KnowledgeBase, product manuals, step-by-step troubleshooting wizards, thousands of example programs, tutorials, application notes, instrument drivers, and so on. Registered users also receive access to the NI Discussion Forums at ni.com/forums. NI Applications Engineers make sure every question submitted online receives an answer.
 - **Software Support Service Membership**—The Standard Service Program (SSP) is a renewable one-year subscription included with almost every NI software product, including NI Developer Suite. This program entitles members to direct access to NI Applications Engineers through phone and email for one-to-one technical support, as well as exclusive access to online training modules at ni.com/self-paced-training. NI also offers flexible extended contract options that guarantee your SSP benefits are available without interruption for as long as you need them. Visit ni.com/ssp for more information.
- **Declaration of Conformity (DoC)**—A DoC is our claim of compliance with the Council of the European Communities using the manufacturer’s declaration of conformity. This system affords the user protection for electromagnetic compatibility (EMC) and product safety. You can obtain the DoC for your product by visiting ni.com/certification.

For information about other technical support options in your area, visit ni.com/services, or contact your local office at ni.com/contact.

You also can visit the Worldwide Offices section of ni.com/niglobal to access the branch office websites, which provide up-to-date contact information, support phone numbers, email addresses, and current events.

Glossary

Symbol	Prefix	Value
p	pico	10^{-12}
n	nano	10^{-9}
μ	micro	10^{-6}
m	milli	10^{-3}
k	kilo	10^3
M	mega	10^6
G	giga	10^9
T	tera	10^{12}

Symbols

- ° Degrees.
- \geq Equal or greater than.
- \leq Equal or less than.
- % Percent.

A

- A Amperes.
- AC Alternating current.
- ANSI American National Standards Institute.
- Auto Automatic fan speed control.
- AWG American Wire Gauge.

B

backplane An assembly, typically a printed circuit board, with connectors and signal paths that bus the connector pins.

C

C Celsius.

cfm Cubic feet per minute.

CFR Code of Federal Regulations.

cm Centimeters.

CompactPCI An adaptation of the Peripheral Component Interconnect (PCI) Specification 2.1 or later for industrial and/or embedded applications requiring a more robust mechanical form factor than desktop PCI. It uses industry standard mechanical components and high-performance connector technologies to provide an optimized system intended for rugged applications. It is electrically compatible with the PCI Specification, which enables low-cost PCI components to be utilized in a mechanical form factor suited for rugged environments.

CSA Canadian Standards Association.

D

daisy-chain A method of propagating signals along a bus, in which the devices are prioritized on the basis of their position on the bus.

DC Direct current.

DoC Declaration of Conformity.

E

efficiency Ratio of output power to input power, expressed as a percentage.

EIA Electronic Industries Association.

EMC	Electromagnetic Compatibility.
EMI	Electromagnetic Interference.
F	
FCC	Federal Communications Commission.
filler panel	A blank module front panel used to fill empty slots in the chassis.
G	
g	(1) grams; (2) a measure of acceleration equal to 9.8 m/s^2 .
GPIO	General Purpose Interface Bus (IEEE 488).
g_{RMS}	A measure of random vibration. The root mean square of acceleration levels in a random vibration test profile.
H	
hr	Hours.
Hz	Hertz; cycles per second.
I	
IEC	International Electrotechnical Commission; an organization that sets international electrical and electronics standards.
IEEE	Institute of Electrical and Electronics Engineers.
I_{MP}	Mainframe peak current.
in.	Inches.
inhibit	To turn off.

J

jitter A measure of the small, rapid variations in clock transition times from their nominal regular intervals. Units: seconds RMS.

K

kg Kilograms.

km Kilometers.

L

lb Pounds.

LED Light emitting diode.

line regulation The maximum steady-state percentage that a DC voltage output will change as a result of a specified change in input AC voltage (step change from 90 to 132 VAC or 180 to 264 VAC).

load regulation The maximum steady-state percentage that a DC voltage output will change as a result of a step change from no-load to full-load output current.

M

m Meters.

MHz Megahertz. One million Hertz; one Hertz equals one cycle per second.

mi Miles.

ms Milliseconds.

MTBF Mean time between failure.

MTTR Mean time to repair.

N

NEMA	National Electrical Manufacturers Association.
NI	National Instruments.

P

power supply shuttle	A removable module that contains the chassis power supply.
PXI	PCI eXtensions for Instrumentation.
PXI_CLK10	10 MHz PXI system reference clock.

R

RH	Relative humidity.
RMS	Root mean square.

S

s	Seconds.
skew	Deviation in signal transmission times.
slot blocker	An assembly installed into an empty slot to improve the airflow in adjacent slots.
SMA	SubMiniature version A connector; a commonly used coaxial connector.
standby	The backplane is unpowered (off), but the chassis is still connected to AC power mains.
System controller	A module configured for installation in Slot 1 of a PXI chassis. This device is unique in the PXI system in that it performs the system controller functions, including clock sourcing and arbitration for data transfers across the backplane. Installing such a device into any other slot can damage the device, the PXI backplane, or both.

Glossary

system reference clock A 10 MHz clock, also called PXI_CLK10, that is distributed to all peripheral slots in the chassis, as well as a BNC connector on the rear of chassis labeled *10 MHz REF OUT*. The system reference clock can be used for synchronization of multiple modules in a measurement or control system. The 10 MHz REF IN and OUT BNC connectors on the rear of the chassis can be used to synchronize multiple chassis to one reference clock. The PXI backplane specification defines implementation guidelines for PXI_CLK10.

System Timing slot This slot is located at slot 4 and has dedicated trigger lines to other slots.

T

TTL Transistor-transistor logic.

U

UL Underwriter's Laboratories.

V

V Volts.

VAC Volts alternating current.

V_{pp} Peak-to-peak voltage.

W

W Watts.

Index

A

AC power cables (table), 1-2

B

backplane

- hybrid peripheral slots, 1-8
- interoperability with CompactPCI, 1-5
- overview, 1-5
- PXI local bus, routing, 1-10
- PXIe_SYNC_CTRL, 1-13
- specifications, A-7
- system controller slot, 1-6
- system reference clock, 1-11
- system timing slot, 1-9
- trigger bus, 1-10

C

- cables, power (table), 1-2
- CE compliance specifications, A-6
- chassis ambient temperature definitions, 2-4
- chassis cooling considerations
 - ambient temperature definitions, 2-4
 - clearances, 2-2
- chassis initialization file, 2-17
- clearances for chassis cooling, 2-2
- CLK10 rear connectors, 2-14
- CompactPCI
 - interoperability with NI PXIe-1085
 - backplane, 1-5
- configuration. *See* installation, configuration, and operation
- connector pinouts. *See* pinouts
- cooling
 - air cooling of NI PXIe-1085 series
 - chassis, 2-2
 - filler panel installation, 2-4
 - setting fan speed, 2-4
 - slot blocker installation, 2-4

D

- default configuration settings, 2-10
- documentation, related, *vii*

E

- electromagnetic compatibility, A-5
- EMC filler panel kit, 1-5
- environmental management
 - specifications, A-6
- Ethernet LED behavior (figure), 2-10
- external clock source specifications, A-8

F

- fan module, replacing, 1-5, 3-6
- fan, setting speed, 2-4
- filler panel installation, 2-4
- front panel, securing, 2-5

G

- ground, connecting, 2-6

H

- hybrid peripheral slots, description, 1-8
- hybrid slot pinouts
 - P1 connector (table), B-9
 - XP3 connector (table), B-10
 - XP4 connector (table), B-10

I

- IEC 320 inlet, 2-6
- inhibit mode switch, 2-14
- installation, configuration, and operation
 - chassis initialization file, 2-17
 - connecting safety ground, 2-6
 - filler panel installation, 2-4
 - high vibration environment, 2-4
 - installing a PXI Express system controller, 2-7
 - peripheral module installation, 2-8
 - PXI Express configuration in
 - MAX, 2-15
 - PXI-1 configuration in MAX, 2-15
 - rack mounting, 2-5
 - remote voltage monitoring and
 - inhibiting interface, 2-12

- setting fan speed, 2-4
- site considerations, 2-2
- slot blocker installation, 2-4
- testing power up, 2-6
- unpacking the NI PXIe-1085, 1-1

interoperability with CompactPCI, 1-5

K

- key features, 1-2
- kit contents, 1-1

L

LED indicators, 2-11

- fan module (figure), 2-12
- fan module LED states (table), 2-12
- front panel LED states (table), 2-11

M

maintenance of NI PXIe-1085 chassis, 3-1

- cleaning
 - exterior cleaning, 3-2
 - interior cleaning, 3-1
- preparation, 3-1
- resetting the AC mains circuit breaker, 3-2
- service interval, 3-1
- static discharge damage (caution), 3-1

N

NI PXIe-1085 series backplane

- hybrid peripheral slots, 1-8
- interoperability with CompactPCI, 1-5
- overview, 1-5
- PXI local bus, routing, 1-10
- PXIe_SYNC_CTRL, 1-13
- specifications, A-7
- system controller slot, 1-6
- system reference clock, 1-11
- system timing slot, 1-9
- trigger bus, 1-10

NI PXIe-1085 series chassis

- fan speed, setting, 2-4
- installation. *See* installation, configuration, and operation

- key features, 1-2
- maintenance. *See* maintenance of NI PXIe-1085 series chassis
- optional equipment, 1-5
- rack mounting, 2-5
- safety ground, connecting, 2-6
- unpacking, 1-1

O

- optional equipment, 1-5

P

peripheral module installation, 2-8

peripheral slot pinouts

- P1 connector (table), B-7
- P2 connector (table), B-8

pinouts, B-1

- 8-pin connector (table), 2-13

power cables (table), 1-2

power supply

- connecting to, 2-6
- remote voltage monitoring and inhibiting interface, 2-12
- replacement, 1-5
- replacing, 3-3
 - configuration, 3-5
 - connecting safety ground, 3-6
 - connecting to power source, 3-6
 - installation, 3-5
 - removal, 3-3
- voltages at voltage monitoring connector (table), 2-13

power up, testing, 2-6

PXI differential star trigger specifications (PXIe-DSTARA, PXIe-DSTARB, PXIe-DSTARC), A-9

PXI Express configuration in MAX, 2-15

PXI Express system controller, 2-7

PXI local bus, routing, 1-10

PXI star trigger specifications, A-8

PXI-1 configuration in MAX, 2-15

PXIe_SYNC_CTRL, 1-13

- specifications, A-8

R

- rack mount kit dimensions (figure), A-12
- rack mounting, 2-5
 - kit, 1-5
- rear 8-pin connector
 - pinout (table), 2-13
 - power supply voltages (table), 2-14
- related documentation, *vii*
- remote system monitoring, 2-9
- remote voltage monitoring and inhibiting interface, 2-12
- replacement fan modules, 1-5
- replacement power supply, 1-5
- replacing the power supply, 3-3, 3-6

S

- safety and caution notices, 2-1
- safety ground, connecting, 2-6
- safety, specifications, A-5
- service interval, 3-1
- setting fan speed, 2-4
- slot blocker
 - installation, 2-4
 - kit, 1-5
- specifications
 - acoustic emissions
 - sound power, A-5
 - sound pressure level (at operator position), A-5
 - backplane
 - 10 MHz system reference clock (PXI_CLK10), A-7
 - 100 MHz Reference Out BNC, A-8
 - 100 MHz system reference clock (PXIe_CLK100 and PXIe_SYNC100), A-8
 - CE compliance, A-6
 - chassis cooling, A-4
 - electrical
 - AC input, A-1
 - DC output, A-2
 - electromagnetic compatibility, A-5
 - environmental
 - management, A-6
 - operating environment, A-4

- storage environment, A-4
- external clock source, A-8
- mechanical, A-9
- PXI differential star triggers
 - (PXIe-DSTARA, PXIe-DSTARB, PXIe-DSTARC), A-9
- PXI star trigger, A-8
- PXIe_SYNC_CTRL, A-8
- rack mount kit dimensions (figure), A-12
- safety, A-5
- shock and vibration, A-5
- system reference clocks, A-7
- static discharge damage (caution), 3-1
- system controller slot
 - description, 1-6
 - pinouts
 - XP1 connector (table), B-2
 - XP2 connector (table), B-2
 - XP3 connector (table), B-3
 - XP4 connector (table), B-3
- system reference clock, 1-11
 - specifications, A-7
- system timing slot
 - description, 1-9
 - pinouts
 - TP1 connector (table), B-4
 - TP2 connector (table), B-5
 - XP3 connector (table), B-6
 - XP4 connector (table), B-7

T

- testing power up, 2-6
- trigger bus, 1-10

U

- unpacking the NI PXIe-1085 series chassis, 1-1

V

- voltages at voltage monitoring connector (table), 2-14