

---

# NI-9247 Getting Started

---

2024-10-11



# Contents

Before You Begin .....	3
Safety Guidelines .....	3
Safety Guidelines for Hazardous Voltages .....	3
Safety Voltages .....	4
Electromagnetic Compatibility Guidelines .....	5
Special Conditions for Marine Applications .....	5
Preparing the Environment .....	6
Connecting the NI 9247 .....	6
Connecting Cables Using Ring Lug Connectors .....	7
Installing the NI 9247 Backshell .....	8
Connecting Phase Measurements .....	8
High-Vibration Applications .....	9
NI Services .....	9

# Before You Begin

Read the **NI 9247 Safety, Environmental, and Regulatory Information** and complete the software and hardware installation procedures in your chassis documentation.

## Safety Guidelines



**Caution** Observe all instructions and cautions in the user documentation. Using the product in a manner not specified can damage the product and compromise the built-in safety protection.



**Attention** Suivez toutes les instructions et respectez toutes les mises en garde de la documentation d'utilisation. L'utilisation du produit de toute autre façon que celle spécifiée risque de l'endommager et de compromettre la protection de sécurité intégrée.

## Safety Guidelines for Hazardous Voltages



**Caution** Ensure that hazardous voltage wiring is performed only by qualified personnel adhering to local electrical standards.



**Caution** Do not mix hazardous voltage circuits and human-accessible circuits on the same module.



**Caution** Ensure that devices and circuits connected to the module are properly insulated from human contact.



**Caution** When module terminals are hazardous voltage LIVE ( $>42.4 V_{pk}/60 V$

DC), you must ensure that devices and circuits connected to the module are properly insulated from human contact.

## Safety Voltages

Connect only voltages that are within the following limits:

Maximum working voltage, channel-to-earth ground	
<b>Continuous</b>	
Up to 2,000 m altitude	300 Vrms, Measurement Category III
Up to 5,000 m altitude	150 Vrms, Measurement Category III or 300 Vrms, Measurement Category II
Maximum working voltage, channel-to-channel	
<b>Continuous</b>	
Up to 2,000 m altitude	480 Vrms, Measurement Category III
Up to 5,000 m altitude	300 Vrms, Measurement Category III or 480 Vrms, Measurement Category II
<b>Withstand</b>	
Channel-to-channel	3510 Vrms, verified by a 5 s dielectric withstand test
Channel-to-earth ground	3510 Vrms, verified by a 5 s dielectric withstand test

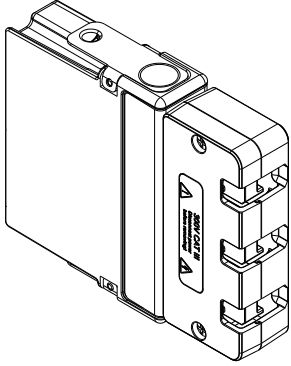

**Caution** The NI 9247 ships with a connector backshell to ensure that the terminals are not accessible. Do not operate the device without first installing this backshell.

**Figure 1.** NI 9247 with Backshell**Related concepts:**

- [Installing the NI 9247 Backshell](#)

## Electromagnetic Compatibility Guidelines

This product was tested and complies with the regulatory requirements and limits for electromagnetic compatibility (EMC) stated in the product specifications. These requirements and limits provide reasonable protection against harmful interference when the product is operated in the intended operational electromagnetic environment.

This product is intended for use in industrial locations. However, harmful interference may occur in some installations, when the product is connected to a peripheral device or test object, or if the product is used in residential or commercial areas. To minimize interference with radio and television reception and prevent unacceptable performance degradation, install and use this product in strict accordance with the instructions in the product documentation.

Furthermore, any changes or modifications to the product not expressly approved by National Instruments could void your authority to operate it under your local regulatory rules.

## Special Conditions for Marine Applications

Some products are approved for marine (shipboard) applications. To verify marine approval certification for a product, visit [ni.com/product-certifications](https://ni.com/product-certifications), search by

model number, and click the appropriate link.



**Notice** In order to meet the EMC requirements for marine applications, install the product in a shielded enclosure with shielded and/or filtered power and input/output ports. In addition, take precautions when designing, selecting, and installing measurement probes and cables to ensure that the desired EMC performance is attained.

## Preparing the Environment

Ensure that the environment in which you are using the NI 9247 meets the following specifications.

Operating temperature (IEC 60068-2-1, IEC 60068-2-2)	-40 °C to 70 °C
Operating humidity (IEC 60068-2-30)	10% RH to 90% RH, noncondensing
Pollution Degree	2
Maximum altitude	5,000 m

Indoor use only.



**Note** Refer to the *NI 9247 Specifications* on [ni.com/manuals](https://ni.com/manuals) for complete specifications.

## Connecting the NI 9247

The NI 9247 provides connection for three analog input channels.

Figure 2. NI 9247 Pinout

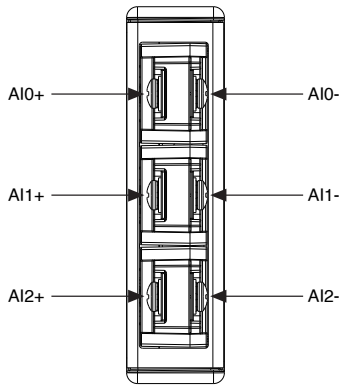

**Note** The NI 9247 does not measure DC currents.



**Caution** Connecting a DC current source to the NI 9247 outside of the specifications stated in the *NI 9247 Datasheet* may lead to invalid measurements. Refer to the datasheet on [ni.com/manuals](http://ni.com/manuals) for the NI 9247 specifications.

## Connecting Cables Using Ring Lug Connectors

Complete the following steps to connect cables using ring lug connectors. Use 5.26 mm<sup>2</sup> (10 AWG) cables.

Figure 4. Installing Cables

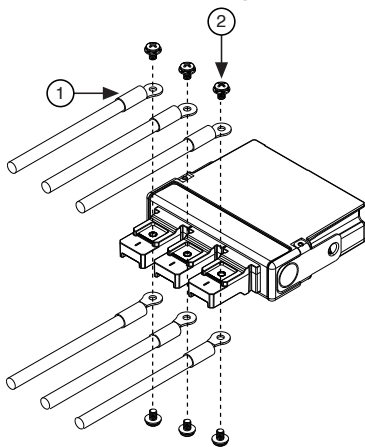

1. Align the cables with the device terminals.
2. Secure the cables using the ring lug screws. Tighten the screws to 1.36 N · m (12 lb ·

in.) torque.

## Installing the NI 9247 Backshell

Complete the following steps to install the NI 9247 backshell.

**Figure 4.** Connector Backshell Installation

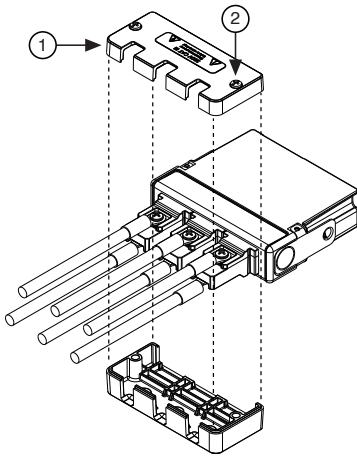

1. Align the backshell components with the device terminals.
2. Secure the backshell using the captive screws. Tighten to  $0.45 \text{ N} \cdot \text{m}$  ( $4 \text{ lb} \cdot \text{in.}$ ) torque.

## Connecting Phase Measurements

You can connect three-phase measurement configurations and single-phase measurement configurations to the NI 9247.

You can connect a current source to the NI 9247 for single-phase measurements. For grounded current sources, connect to the chassis ground.

**Figure 5.** Connecting a Grounded or Floating Current Source

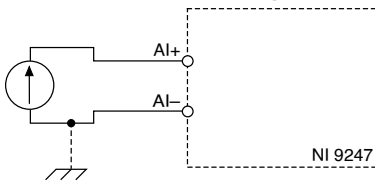

For three-phase measurements, connect three current sources to the NI 9247.



## High-Vibration Applications

Proper strain relief of 5.26 mm<sup>2</sup> (10 AWG) cable is required to meet the shock and vibration performance specifications stated in the **NI 9247 Datasheet** on [ni.com/manuals](https://ni.com/manuals). Strain relieve all cabling as close to the chassis mounting plate as possible to reduce the stresses exerted on the module. Ensure that you do not directionally bias the module when applying strain relief.

## NI Services

Visit [ni.com/support](https://ni.com/support) to find support resources including documentation, downloads, and troubleshooting and application development self-help such as tutorials and examples.

Visit [ni.com/services](https://ni.com/services) to learn about NI service offerings such as calibration options, repair, and replacement.

Visit [ni.com/register](https://ni.com/register) to register your NI product. Product registration facilitates technical support and ensures that you receive important information updates from NI.

NI corporate headquarters is located at 11500 N Mopac Expwy, Austin, TX, 78759-3504, USA.