

## COMPREHENSIVE SERVICES

We offer competitive repair and calibration services, as well as easily accessible documentation and free downloadable resources.

## SELL YOUR SURPLUS

We buy new, used, decommissioned, and surplus parts from every NI series. We work out the best solution to suit your individual needs.

 Sell For Cash    Get Credit    Receive a Trade-In Deal

## OBSOLETE NI HARDWARE IN STOCK & READY TO SHIP

We stock **New**, **New Surplus**, **Refurbished**, and **Reconditioned** NI Hardware.



*Bridging the gap between the manufacturer and your legacy test system.*

 1-800-915-6216

 [www.apexwaves.com](http://www.apexwaves.com)

 [sales@apexwaves.com](mailto:sales@apexwaves.com)

*All trademarks, brands, and brand names are the property of their respective owners.*

**Request a Quote**

 **CLICK HERE**

**sbRIO-9627**

# NI sbRIO-9627

## Single-Board RIO OEM Devices

This document describes the features of the NI sbRIO-9627 and contains information about operating the device.

**Figure 1. NI sbRIO-9627 Block Diagram**

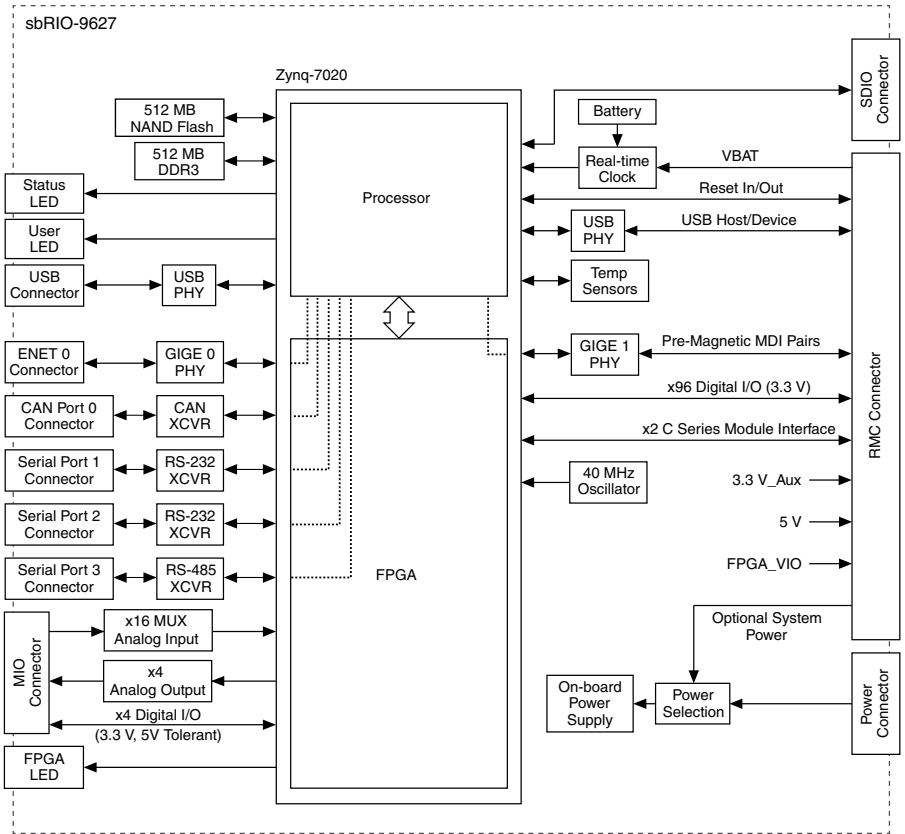

# Contents

---

Mechanical Considerations.....	3
Dimensions.....	4
Maximum Component Heights.....	6
Mounting.....	7
Managing Thermal Conditions.....	11
Validating the System.....	13
Shock and Vibration.....	18
Ports and Connectors.....	18
Connector Descriptions.....	19
Power Connector.....	21
RJ-45 Gigabit Ethernet Port.....	21
USB Host Ports.....	22
SD Connector.....	23
RS-232 Serial Ports.....	23
RS-485 Serial Port.....	24
CAN Port.....	25
MIO Port.....	26
RESET Button.....	26
System Reset.....	27
LEDs.....	27
POWER LED Indicators.....	28
STATUS LED Indicators.....	28
User LEDs.....	29
Ethernet LED Indicators.....	30
Real-Time Clock (RTC) Battery.....	30
Internal Real-Time Clock (RTC).....	31
RIO Mezzanine Card Connector.....	31
RMC Connector Pins.....	32
RMC Connector Pin Listing by Location.....	36
RMC Connector Power Requirements.....	39
RMC Connector Electrical Characteristics.....	39
VIN_Filtered.....	40
RMC VBAT.....	40
USB Support.....	40
RMC Ethernet Support.....	41
C Series DIO.....	41
RMC RST#.....	42
SYS RST#.....	42
FPGA_CONF.....	42
User-Defined FPGA Signals.....	42
Integrated 3.3 V Digital I/O.....	44
Integrated Analog Input.....	45
Analog Input Range.....	45
Integrated Analog Output.....	53
Analog Output Startup and Initialization.....	53

Power Requirements.....	53
Wiring the Power Supply Connector.....	53
Powering On the NI sbRIO Device.....	54
Calculating the Power Requirement.....	54
Configuring the sbRIO-9627.....	56
Connecting the sbRIO-9627 to the Host Computer.....	56
Configuring Startup Options.....	57
Configuring FPGA Startup App.....	59
Connecting CAN Networks.....	59
CAN Bus Topology and Termination.....	59
Cable Specifications.....	60
Termination Resistors.....	60
Cable Lengths.....	61
Number of CAN Nodes.....	61
File System.....	61
Worldwide Support and Services.....	61

## Mechanical Considerations

---

Proper mechanical design is critical for rugged environments in which the NI sbRIO device may be subjected to extreme temperatures, shock, vibration, and other factors. In particular, pay special attention to thermal performance to ensure that your application meets the NI sbRIO device operating requirements.

# Dimensions

The following figures specify dimensions for the sbRIO-9627.

**Figure 2. Primary-Side Dimensions in mm (in.)**

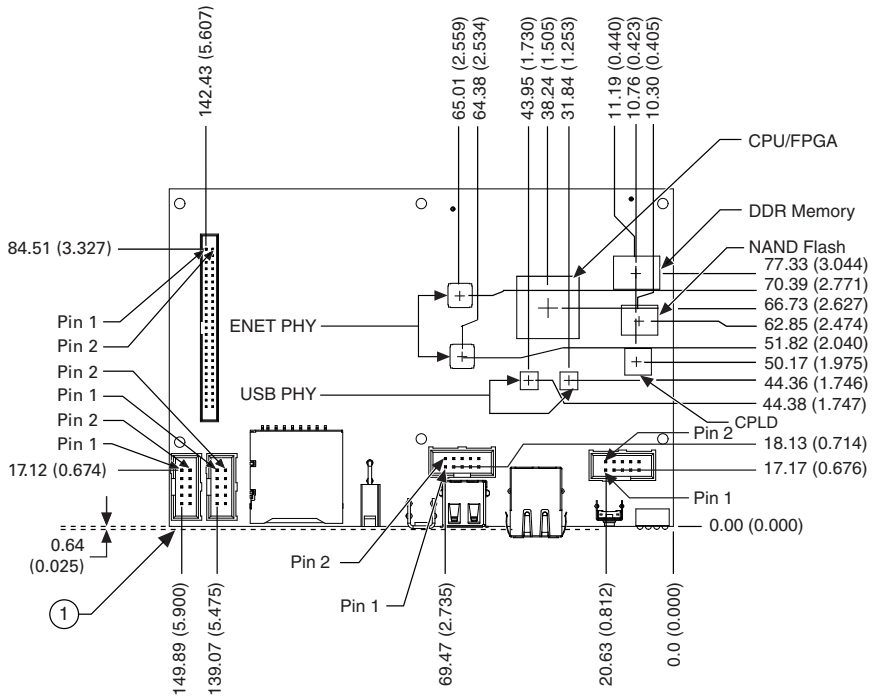

1. Back of Front Panel

**Figure 3. Secondary-Side Dimensions in mm (in.)**

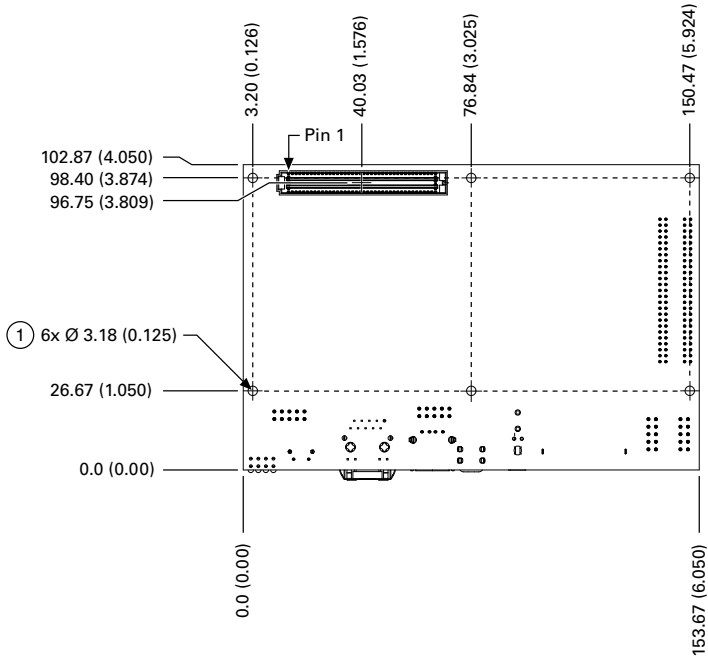

1. Holes and Keepouts Sized for M3 Standoff (4.5 mm Hex) or 4-40 Standoff (3/16-in. Hex)

**Figure 4. Front Dimensions in mm (in.)**

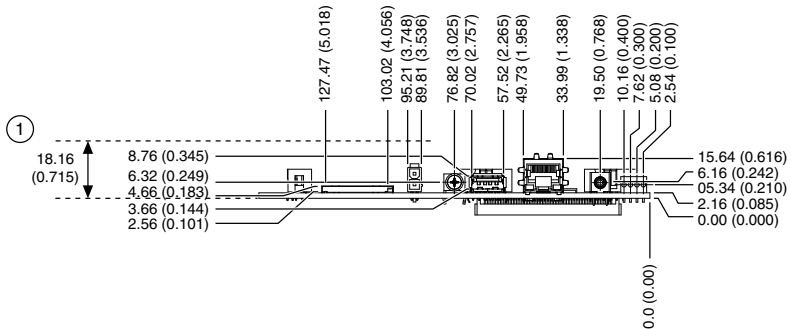

1. Minimum Clearance for Latch on Mating Power Connector



**Tip** For two-dimensional drawings and three-dimensional models of the sbRIO-9627, visit [ni.com/dimensions](https://ni.com/dimensions) and search by model number.

# Maximum Component Heights

The primary side of the sbRIO-9627 is the top side of the PCB populated with the power and Ethernet connectors. The secondary side is the bottom side of the PCB populated with the RMC connector. The following figures show the maximum component heights for the different regions of the primary and secondary sides.



**Note** In addition to the maximum component heights, you must also observe minimum keepaway distances for adjacent PCBs and surfaces.

**Figure 5. Maximum Component Height of Primary Side**

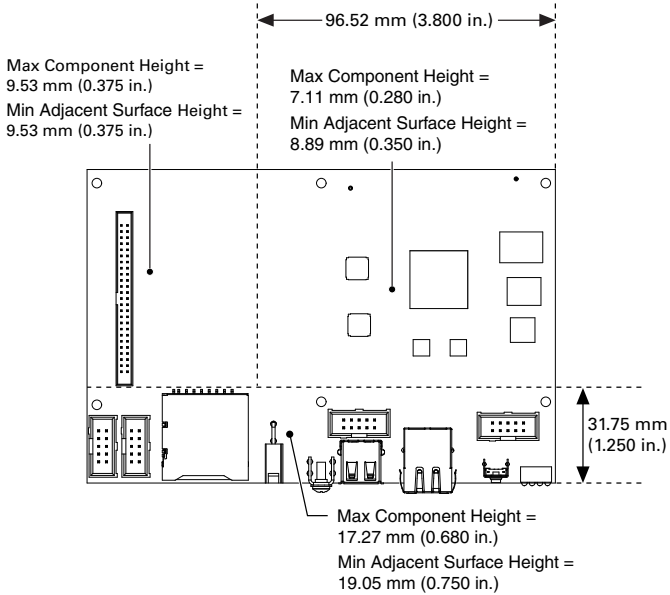

**Figure 6. Maximum Component Height of Secondary Side**

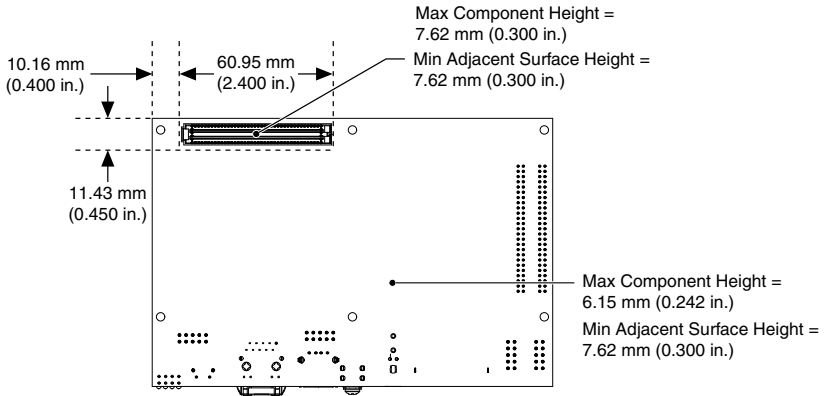

## Mounting

You can mount the NI sbRIO device in a variety of ways in order to maximize system performance. Some mounting methods might require custom fasteners or unique assembly techniques to maintain required connector stack heights and enable improved thermal and structural design for rugged environments.

## Mounting Direction Options

The sbRIO-9627, Thermal Kit for NI sbRIO-9607/9627/9637 (153901-02), and certain RMC accessories are designed to allow traditional M-F standoff threads to pass through and stack in either direction. The following figures show possible mounting configurations and associated fastener types.



## Mounting on a Panel or Plate with Conduction Path

If possible, NI recommends that you mount the sbRIO-9627 on a panel or plate, such that a thermal solution provides a conduction path from the primary side components and is secured to or made from the panel or plate, as shown in the following figure.

**Figure 7. Mounting on a Panel or Plate**

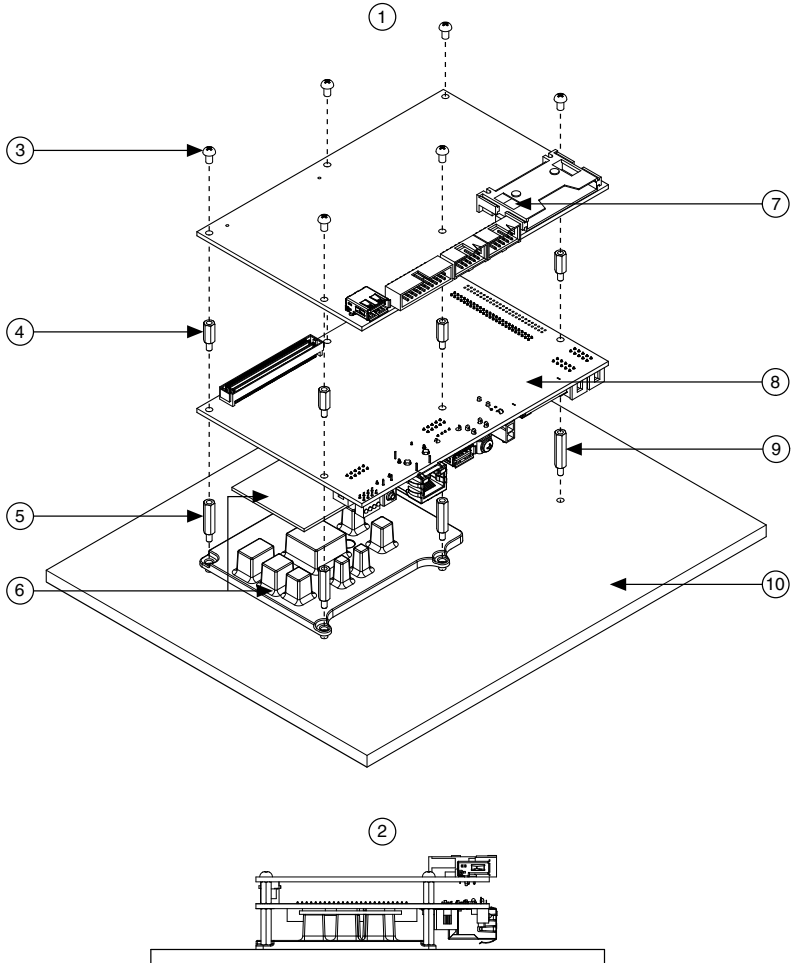

- |   |  |
|---|--|
| 1. Exploded view of all mounting components | 6. Thermal Kit for NI sbRIO-9607/9627/9637 (153901-02) |
| 2. Complete assembled and mounted view      | 7. RMC board   |
| 3. Mounting screws                          | 8. NI sbRIO-9627                                       |
| 4. Standoff, 9.65 mm (0.38 in.)             | 9. Standoff, 18.00 mm (0.71 in.)                       |
| 5. Standoff, 16.00 mm (0.63 in.)            | 10. Mounting surface                                   |

## Mounting on a Panel or Plate with Convection Path

Alternatively, the thermal solution can be used for convection to natural or forced air flow or used in conjunction with a heat sink optimized for the environment.

**Figure 8. Mounting on a Panel or Plate**

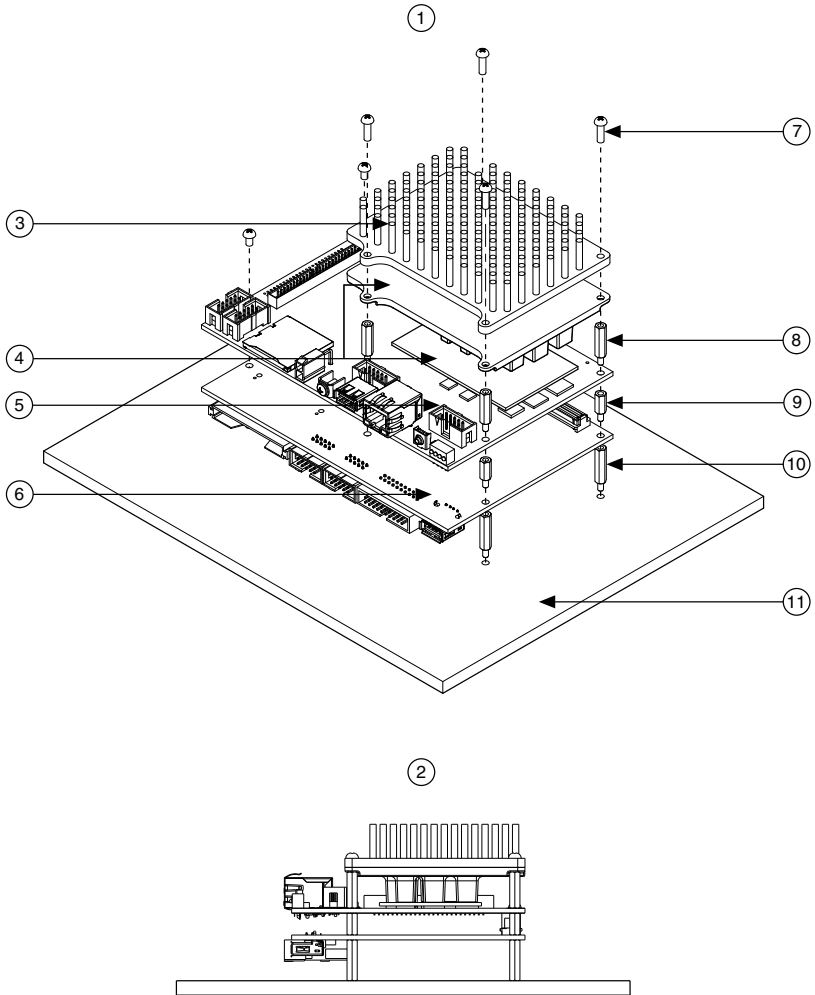

- |  |                                  |
|--|----------------------------------|
| 1. Exploded view of all mounting components            | 7. Mounting screws               |
| 2. Complete assembled and mounted view                 | 8. Standoff, 16.00 mm (0.63 in.) |
| 3. Heatsink  | 9. Standoff, 9.65 mm (0.38 in.)  |
| 4. Thermal Kit for NI sbRIO-9607/9627/9637 (153901-02) | 10. Standoff                     |
| 5. NI sbRIO-9627                                       | 11. Mounting surface             |
| 6. RMC board   |                                  |

## Chassis Grounding Connections

The sbRIO-9627 provides a multi-function bracket that can be used with the supplied 4-40 grounding screw for directly attaching ground connections or for attaching to and grounding a front panel as shown in the following figure.

**Figure 9. sbRIO-9627 Chassis Grounding Screw**

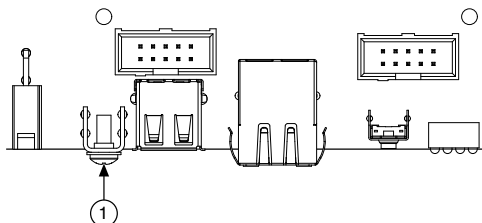

### 1. Chassis Grounding Screw

The front I/O connector shields, chassis ground bracket, and mounting holes near the front I/O are connected together internally to form chassis ground. Chassis ground is capacitively coupled to digital ground near each of the IO connectors. For the best possible ESD protection, connect chassis ground at the mounting holes or the chassis ground bracket to a low-inductance earth ground.

When connecting the NI sbRIO device to external devices, ensure that stray ground currents are not using the device as a return path. Significant stray currents traversing through the NI sbRIO device can result in device failure.

To verify correct grounding of the NI sbRIO device, make sure the current flowing into the power connector equals the current flowing out of the power connector. These currents should be measured with a current probe after final assembly of the end system. Investigate and remove any current differences.

## Managing Thermal Conditions

Due to the small size of the sbRIO-9627, it is very important to appropriately dissipate the heat generated during operation. You must plan for the thermal conditions of your application throughout development and validation. This section provides design recommendations and validation tools and methods for maximizing the thermal performance of the system.

### Designing a Suitable Enclosure

NI sbRIO devices operate as components in a higher-level system and may require an enclosure to protect the internal circuit card assemblies and dissipate heat. For the sbRIO-9627, the system integrator is responsible for designing an enclosure that meets the thermal requirements of your specific application.

NI sbRIO devices integrated into an enclosure or system with proper thermal dissipation can be deployed in high- and low-temperature environments. However, the 85 °C local ambient operating temperature rating of the sbRIO-9627 does not mean that the external temperature of the natural convection environment such as a room or larger enclosure can be 85 °C. In this

way, properly designed NI sbRIO devices may still require an external ambient temperature of 70 °C or less and may still require specific mounting requirements to ensure that the local ambient and thermally-relevant component maximum operating temperatures are within specification.

## Understanding Thermal Specifications

A deployed system has several temperature measurement locations that indicate the thermal performance of the system and the devices the system contains. For example, in a natural convection system, the temperature of a critical component will be higher than the temperature of the air in the immediate vicinity of the component. This local air temperature will also be higher inside an enclosure than in the room ambient that surrounds the enclosure.

The following figure identifies these types of ambient temperatures.

**Figure 10. Ambient Temperatures**

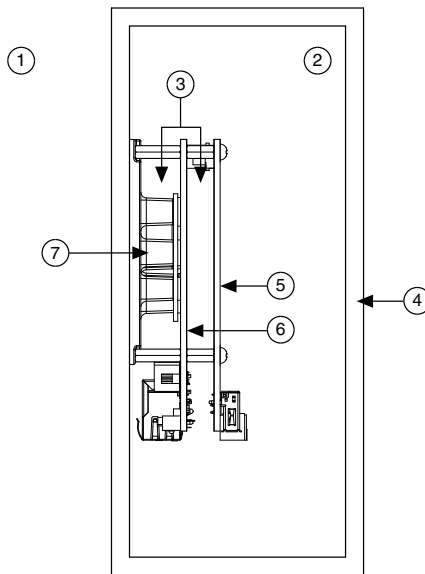

- |   |   |
|---|---|
| 1. External ambient temperature           | 5. RMC board  |
| 2. Internal/enclosure ambient temperature | 6. NI sbRIO-9627  |
| 3. Local ambient temperature              | 7. Thermal Kit for NI sbRIO-9607/9627/9637<br>(153901-02) |
| 4. Enclosure                              |   |

- External ambient—The maximum air temperature of the room or installation location that surrounds the system.
- Internal/enclosure ambient—The maximum air temperature inside the enclosure. This can be measured at various locations within the enclosure and is highly influenced by the proximity and dissipation of devices inside the enclosure.
- Local ambient—The maximum air temperature as specified directly adjacent to the NI sbRIO device. This is measured on all sides of a device that has exposed circuitry.

Because the system integrator may use any number of enclosure sizes, materials, thermal solutions, and room conditions when designing an enclosure for a specific application, NI sbRIO devices are specified in a manner that removes most of these external variables. Therefore, the sbRIO-9627 thermal performance is not determined by measuring the external ambient or internal/enclosure ambient temperatures, but by measuring the local ambient and specific component temperatures. NI provides digitally reported temperatures to help you accurately measure these critical temperatures.

## Validating the System

NI recommends that you use a validation system for an extended period of time in a test environment with the same thermal, environmental, and functional utilization characteristics as the target deployment environment. You are responsible for final validation of your application.

### Validating Temperature Measurements Digitally

To meet the thermal specifications of the sbRIO-9627, you must satisfy the requirements of either the digital or analog thermal validation approach as described in the *NI sbRIO-9627 Specifications* on [ni.com/manuals](http://ni.com/manuals). The sbRIO-9627 includes three onboard temperature-monitoring sensors to simplify validation of a thermal solution. The sensors provide an indication of thermal performance and are used to validate the system digitally.

**Figure 11. Onboard Temperature-Monitoring Sensors**

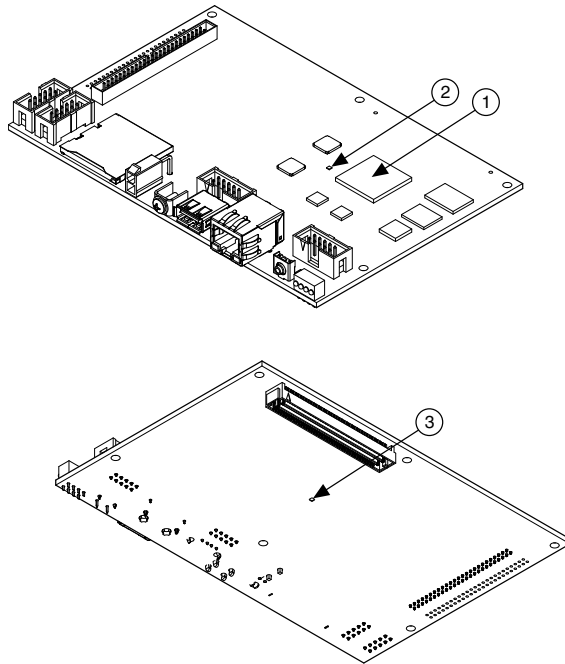

1. CPU/FPGA sensor
2. Primary System sensor
3. Secondary System sensor

- CPU/FPGA sensor—Digitally reports the die junction temperature of the Xilinx Zynq SoC.
- Primary System sensor—Digitally reports the temperature on the Xilinx Zynq SoC side of the circuit card assembly. This value is a conservative approximation of the local ambient temperature on that side of the circuit card assembly.
- Secondary System sensor—Digitally reports the temperature on the SEARAY side of the circuit card assembly. This value is a conservative approximation of the local ambient temperature on that side of the circuit card assembly.

In addition to being useful for system validation, digitally reported temperatures also provide feedback about system health and can be used as triggers or set points.

NI recommends that you monitor the digitally reported temperatures on deployed systems, especially if the temperatures approach the maximum thermal specifications during system validation testing. Monitoring allows individual systems to identify adverse thermal changes caused by differences in environmental, operating, or process conditions.

For more information about how to access and use the digitally reported temperature sensor measurements, visit [ni.com/info](https://ni.com/info) and enter the Info Code `sbriosensors`.

## Managing Power and Feature Utilization

An NI sbRIO device that heavily utilizes all of its performance and features consumes and dissipates substantially more power than an idle device.

Consider the following options for reducing the die junction temperature.

- Design for additional thermal cooling that can appropriately dissipate power
- Reduce device feature utilization



**Note** Your final validation must consider software and hardware utilization that is representative of the final deployment conditions.



**Note** Refer to the *Power Requirements* section of the *NI sbRIO-9627 Specifications* on [ni.com/manuals](http://ni.com/manuals) for specifications that approximate the maximum power requirement for each input rail on the sbRIO device with worst-case silicon manufacturing process and maximum junction temperatures. For a more accurate estimate of the power consumption for a specific application, NI recommends that you directly measure the power the sbRIO device consumes when running your application in an environment that is representative of the intended use case.

## Mounting Recommendations for Maximizing Thermal Performance

Thermal performance of the NI sbRIO device can be maximized by implementing the following recommendations.

- Directly mount a thermal solution such as the Thermal Kit for NI sbRIO-9607/9627/9637 (153901-02) to a thermally conductive surface such as a metal enclosure wall or plate, as shown in the [Mounting on a Panel or Plate with Conduction Path](#) section. An interface material such as thermal grease should be used to maximize the heat transfer from the heat spreader to the enclosure or plate.

If design limitations prevent this solution, you can alternatively attach a heat sink or other thermal solution as shown in the [Mounting on a Panel or Plate with Convection Path](#) section. This solution takes advantage of natural convection or forced cooling provided by a fan.

- Mount the NI sbRIO device vertically with respect to gravity to take advantage of natural convection cooling.
- Mount the NI sbRIO device below and away from other heat-dissipating components.



**Note** Placing the NI sbRIO device within a system or enclosure will also influence thermal performance.

The following figure shows good, better, and best thermal mounting solutions for the sbRIO-9627.



**Figure 12. Thermal Mounting Solutions Comparison**

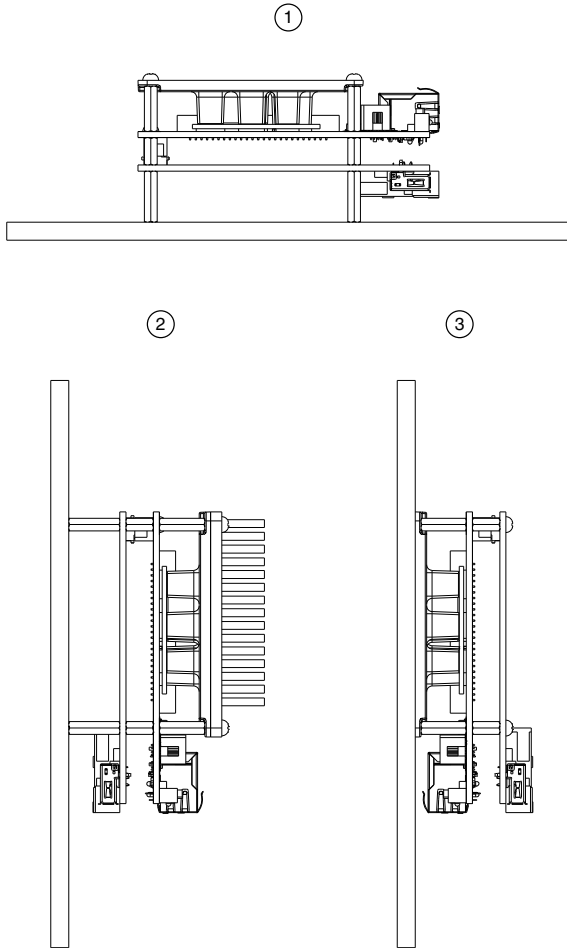

1. Good—Horizontal mounting with no additional thermal provisions
2. Better—Vertical mounting with an attached heat sink
3. Best—Vertical mounting directly to a thermally-conductive wall or plate

## Designing A Thermal Solution

If the Thermal Kit for NI sbRIO-9607/9627/9637 (153901-02) does not satisfy your design requirements, NI recommends replicating the features of the heat spreader into your own thermal solution. Use the pedestal dimensions shown in the following figure and a Bergquist GPVOUS-0.060 thermal gap pad with a fastener assembly rate of 4.23 mm/s (10 in./min.) to prevent damage to the critical components during assembly. NI recommends that you replicate each of the pedestals and not just the pedestal for the CPU/FPGA.

**Figure 13.** sbRIO-9627 Pedestal Dimensions in mm (in.)

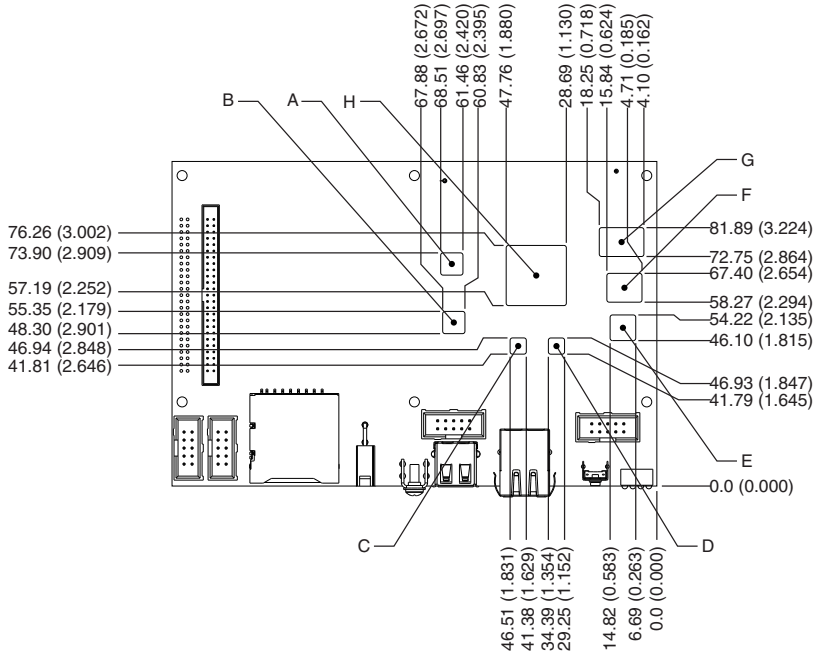

The following table provides the pedestal height from board surface for each corresponding component shown in the previous figure.

**Table 1.** Pedestal Height from Board Surface

Designation	Pedestal Corresponding Component	Pedestal Height from Board Surface
A, B	ENET PHY	2.05 mm (0.081 in.)
C, D	USB PHY	2.00 mm (0.079 in.)
E	CPLD	2.20 mm (0.087 in.)
F	NAND Flash	2.16 mm (0.085 in.)
G	DDR Memory	2.32 mm (0.091 in.)
H	CPU/FPGA	2.51 mm (0.099 in.)



**Note** Pedestals of the same dimensions are allowed to violate the primary side maximum component height keepaway restrictions.



**Note** Gap-filling thermal interface materials between the components and pedestals confined to within the indicated region are allowed to violate the primary side maximum component height keepaway restrictions.



**Note** Pedestals of the same dimensions are allowed to have 0.5 mm (0.02 in.) rounds and 2° draft angles.

## Additional Resources for Managing Thermal Conditions

Visit [ni.com/info](https://ni.com/info) and enter the Info Code `sbriocooling` for the following additional information to help you manage thermal conditions:

- Examples regarding the effect of the design factors discussed in this chapter
- Case study examples to help you estimate the achievable external ambient temperature for a representative system

## Shock and Vibration

The mounting method you use, components you select, and assembly techniques you use influence the ability of the system to resist fretting corrosion and other damage caused by exposure to shock and vibration. Consider the following factors when designing your sbRIO-9627 system to account for shock and vibration:

- In general, shorter SEARAY stack heights perform better than taller stack heights.
- Directly mounting the thermal solution to a rigid surface provides the best performance. If this method is not feasible for your design, minimize the amount of extra mass that only the sbRIO-9627 supports, such as a heat sink or other thermal solution, that is fastened to the four standoffs. If you require substantial thermal solutions, provide additional structural support.
- NI recommends that you use connectors that provide the following benefits:
  - Positive locking
  - Provisions for strain relief
  - Substantial gold plating on pins
- The sbRIO-9627 has been tested to industry specifications for rugged environments.
- NI offers a variety of cable assemblies and other connectivity accessories to complete your system design. Typically, these accessories include the best available designs, materials, and plating to maximize performance and longevity in rugged environments.

## Ports and Connectors

---

The sbRIO-9627 provides the following ports and connectors.

**Figure 14.** sbRIO-9627 Ports and Connectors

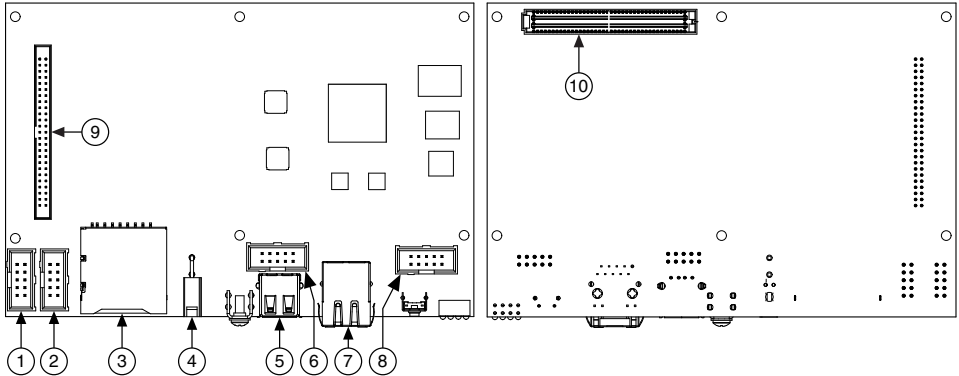

- |                        |                                      |
|------------------------|--------------------------------------|
| 1. W3, RS-485 (ASRL3)  | 6. W1, CAN (CAN0)                    |
| 2. W4, RS-232 (ASRL2)  | 7. J7, RJ-45 Ethernet Port           |
| 3. J6, SDHC            | 8. W2, RS-232 (ASRL1)                |
| 4. J9, Power Connector | 9. J5, MIO                           |
| 5. J10, USB Host Port  | 10. J1, RIO Mezzanine Card Connector |



**Note** Ethernet, CAN, RS-232, RS-485, and RMC processor peripherals created using the CLIP generator are all routed through the FPGA. These peripherals will be temporarily unavailable when the FPGA is reconfigured. Downloading your FPGA application to the flash of the sbRIO-9627 ensures that the FPGA is configured before the driver can access a given peripheral. Refer to the [Configuring FPGA Startup App](#) section in this document for more information.

## Connector Descriptions

The following table lists the connectors on the NI sbRIO device and the part number and manufacturer of each connector. Refer to the manufacturer for information about using and matching these connectors.

**Table 2. NI sbRIO Connector Descriptions**

Connector	Description	Manufacturer, Part Number	Recommended Mating Connector	NI Solution
Power	2-position, mini-fit JR, H = 10.439 mm (0.411 in.)	Molex, 46999-0144	Molex, 50-36-1673 w/ 0457501211	NI, Power Plug Assembly, 152834-01
RS-232/485/CAN IDC Header	10-pin, 0.100 in. CT, shrouded, H = 9.398 mm (0.370 in.)	Samtec, TST-105-01-L-D	Tyco, 1658622-1	NI, 10-pin to 9-pin D-SUB, 153158-10
50-Pin IDC Header	50-pin, 2 mm CT, Shrouded, H = 3.937 mm (0.155 in.)	Samtec, STMM-125-02-L-D	Tyco, 2-111623-6	NI, 50-position ribbon cable, 154041-12
RMC Connector	240-pin, 40 × 6 position, high density open pin field SEARAY	Samtec, SEAF-40-06.5-S-06-2-A-K-TR	Samtec, SEAM-40-03.0-S-06-2-A-K-TR	—

Samtec SEAM connectors come in multiple heights, indicated in millimeters by the *xx.x* portion of the SEAM-40-*xx.x*-S-06-2 example part number. You can order a mating connector for the RMC connector from Samtec, the connector manufacturer, or from a distributor such as Arrow or Avnet.

The height of the mating connector you select to mate to the RMC connector determines the height of the standoffs you need. Samtec requires that standoffs be 0.15 mm (0.006 in.) taller than the combined height of the RMC and mating connectors. Therefore, to determine the required standoff height, you must add the heights of the connectors plus 0.15 mm (0.006 in.).

The following table provides an example standoff height calculation using a Samtec SEAM-40-03.0-S-06-2-A-K-TR mating connector.

**Table 3.** Example Connector Configuration and Calculated Standoff Height

Component	Manufacturer, Part Number	Height
RMC connector	Samtec SEAF-40-06.5-S-06-2-A-K-TR	6.50 mm (0.256 in.)
Mating connector	Samtec SEAM-40-03.0-S-06-2-A-K-TR	3.00 mm (0.118 in.)
Required additional standoff height	—	0.15 mm (0.006 in.)
Total calculated standoff height	—	9.65 mm (0.380 in.)

Consult Samtec for alternative heights and options. You must observe keepaways and maximum heights with all RMC and mating connector combinations.

Refer to the [RIO Mezzanine Card Connector](#) section of this document for more information about connecting an RMC.

## Power Connector

The sbRIO-9627 has a power connector to which you can connect a power supply. The following table shows the pinout for the power connector.

**Table 4.** Power Connector Pinout

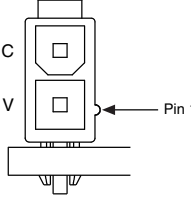
Pinout	Pin	Description
	C	Common
	V	Power input

The sbRIO-9627 has reverse-voltage protection.

## RJ-45 Gigabit Ethernet Port

The sbRIO-9627 has a tri-speed RJ-45 Gigabit Ethernet port. By default, the Ethernet port is enabled and configured to obtain an IP address automatically. The Ethernet port can be configured in MAX.

The following table shows the pinout for the RJ-45 Gigabit Ethernet port.

**Table 5. RJ-45 Gigabit Ethernet Port Pinout**

Fast Ethernet Signal	Gigabit Ethernet Signal	Pin	Pinout
TX+	TX_A+	1	
TX-	TX_A-	2	
RX+	RX_B+	3	
No Connect	TX_C+	4	
No Connect	TX_C-	5	
RX-	RX_B-	6	
No Connect	RX_D+	7	
No Connect	RX_D-	8	



**Note** Both Ethernet ports perform automatic crossover configuration so you do not need to use a crossover cable to connect to a host computer.

The following NI Ethernet cables are available for the sbRIO-9627.

**Table 6. RJ-45 Gigabit Ethernet Cables**

Cables	Length	Part Number
CAT-5E Ethernet Cable, shielded	2 m	151733-02
	5 m	151733-05
	10 m	151733-10

## USB Host Ports

The USB host ports on the sbRIO-9627 support common USB mass-storage devices such as USB Flash drives and USB-to-IDE adapters formatted with FAT16 and FAT32 file systems. The sbRIO-9627 USB host port supports Web cameras that conform to the USB Video Device Class (UVC) protocol as well as machine vision cameras that conform to the USB3 Vision standard and are USB 2.0-compatible.



**Caution** Do not hot-swap USB devices while the sbRIO-9627 is in a hazardous location or connected to high voltages. If the sbRIO-9627 is not in a hazardous location, you can connect and disconnect USB devices without affecting operation.

The sbRIO-9627 provides a multi-function bracket that can be used in conjunction with a 1 mm (0.039 in.) thick front panel and a 6.35 mm (0.250 in.) length 4-40 M-F standoff to provide retention for the USB connector. The following table shows the pinout for the USB host ports.

**Table 7.** USB Host Port Pinout

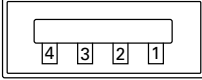
Pinout	Pin	Signal	Description
	1	VCC	Cable power (5 V)
	2	D-	USB data-
	3	D+	USB data+
	4	GND	Ground

The following NI cable is available for the sbRIO-9627.

**Table 8.** USB Host Port Cable

Cable	Length	Part Number
USB Extension with Retention, Type A Connectors	0.5 m	152166-0R5
	2 m	152166-02

## SD Connector

The sbRIO-9627 has an SD card connector that can be used to connect to either SD or SDHC cards.

The following accessories are available to be used with the SD Connector.

Accessory	Part Number
512 MB Industrially-Rated SD Card	780245-01
2 GB Industrially-Rated SD Card	780246-01
16 GB Industrially-Rated SD card	783658-01
32 GB Industrially-Rated SD card	783659-01

## RS-232 Serial Ports

The sbRIO-9627 has two RS-232 serial ports that are implemented with a shrouded header, 10-position modular jack to which you can connect devices such as displays or input devices. Use the Serial VIs to read from and write to the serial ports. Refer to the *LabVIEW Help* for information about the Serial VIs.

Find examples on how to use NI-Serial or NI-VISA to perform serial communication in the NI Example Finder. Select **Help»Find Examples** in LabVIEW to launch the NI Example Finder.



**Note** The ASRL1 RS-232 serial port cannot be accessed by the user application when the Console Out startup option is enabled.



The following figure shows the pinout for the RS-232 serial ports.

**Figure 15. RS-232 Serial Port Pinout**

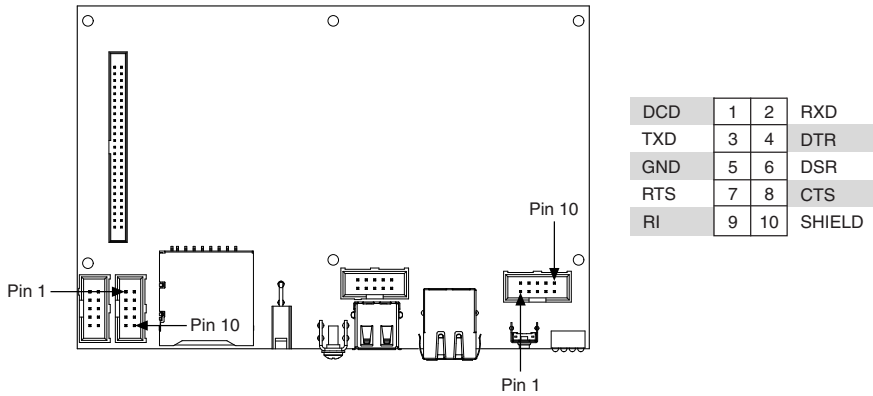

The following accessories are available to connect the RS-232 serial ports.

**Table 9. RS-232 Serial Port Accessories**

Accessory	Part Number
NI Single-Board RIO 10-pin header to 9-pin D-SUB	153158-10

## RS-485 Serial Port

The sbRIO-9627 has an RS-485 serial port that is implemented with a shrouded header, 10-position modular jack to which you can connect devices such as displays or input devices. Use the Serial VIs to read from and write to the serial port. Refer to the *LabVIEW Help* for information about the Serial VIs.

Find examples on how to use NI-Serial or NI-VISA to perform serial communication in the NI Example Finder. Select **Help»Find Examples** in LabVIEW to launch the NI Example Finder.

The following figure shows the pinout for the RS-485 serial port.

**Figure 16. RS-485 Serial Port Pinout**

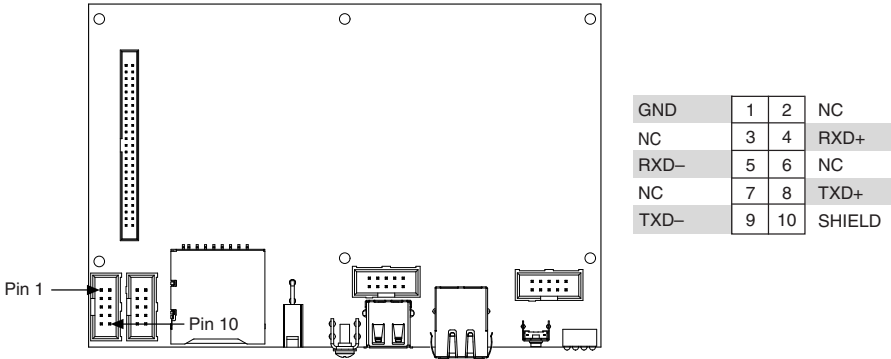

The following accessories are available to connect the RS-485 serial port.

**Table 10. RS-485 Serial Port Accessories**

Accessory	Part Number
NI Single-Board RIO 10-pin header to 9-pin D-SUB	153158-10

## CAN Port

The sbRIO-9627 has a CAN port that is implemented with a shrouded header, 10-position modular jack to provide connections to a CAN bus.

The following figure shows the pinout for the CAN port.

**Figure 17. CAN Port Pinout**

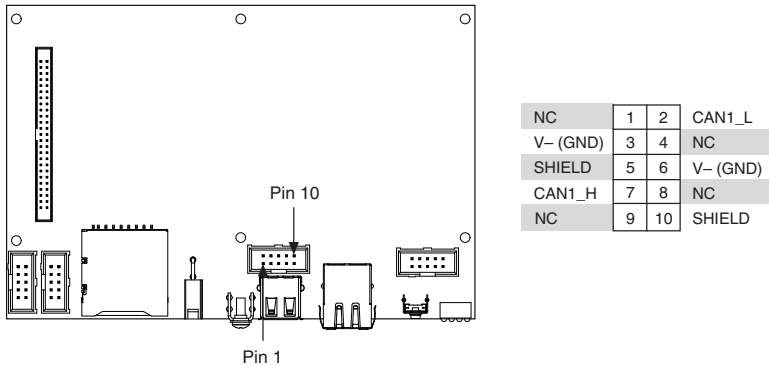

The following accessories are available to connect the CAN port.

**Table 11. CAN Port Accessories**

Accessory	Part Number
NI Single-Board RIO 10-pin header to 9-pin D-SUB	153158-10

## MIO Port

The sbRIO-9627 has an MIO port for input and output configurations.

The following figure shows the pinout for the MIO port.

**Figure 18. MIO Port Pinout**

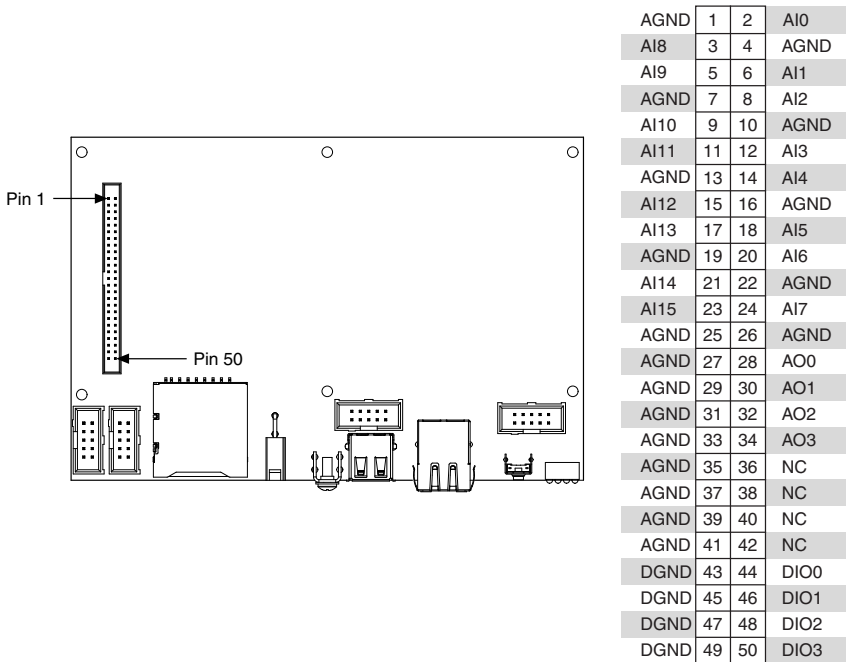

## RESET Button

Press the RESET button to reset the processor in a similar manner as cycling power.

**Figure 19. RESET button**

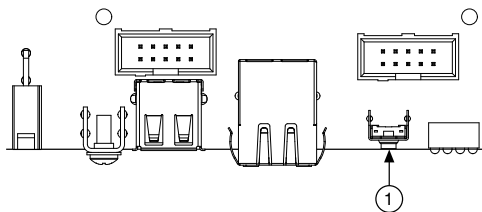

1. RESET button

## System Reset

The following figure shows the reset behavior of the sbRIO-9627.

**Figure 20. Reset Button Behavior**

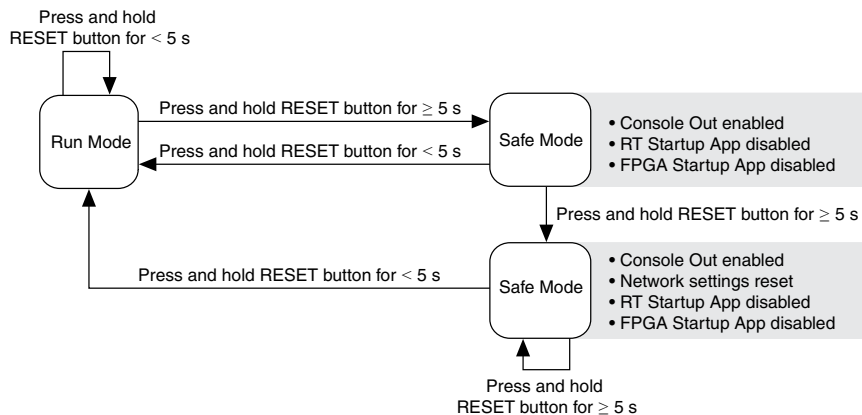

## LEDs

The sbRIO-9627 provides the following LEDs.

**Figure 21. sbRIO-9627 LEDs**

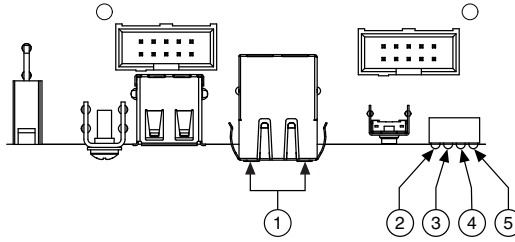

- 
- |                          |                   |
|--------------------------|-------------------|
| 1. Gigabit Ethernet LEDs | 4. USER1 LED      |
| 2. POWER LED             | 5. USER FPGA1 LED |
| 3. STATUS LED            |                   |
- 

## POWER LED Indicators

The following table lists the POWER LED indicators.

**Table 12. POWER LED Indicators**

LED Color	LED Pattern	Indication
Green	Solid	The sbRIO-9627 is powered ON.
—	Off	The sbRIO-9627 is powered OFF.

## STATUS LED Indicators

The following table lists the STATUS LED indicators.

**Table 13. STATUS LED Indicators**

LED Pattern	Indication
Blinks twice and pauses	<p>The sbRIO-9627 is in safe mode. Software is not installed, which is the factory default state, or software has been improperly installed on the sbRIO-9627.</p> <p>An error can occur when an attempt to upgrade the software is interrupted. Reinstall software on the sbRIO-9627. Refer to the <i>Measurement &amp; Automation Explorer (MAX) Help</i> for information about installing software on the sbRIO-9627.</p>
Blinks three times and pauses	<p>The sbRIO-9627 is in user-directed safe mode, or the sbRIO-9627 is in install mode to indicate that software is currently being installed.</p> <p>This pattern may also indicate that the user has forced the sbRIO-9627 to boot into safe mode by pressing the reset button for longer than five seconds or by enabling safe mode in MAX. Refer to the <i>Measurement &amp; Automation Explorer (MAX) Help</i> for information about safe mode.</p>
Blinks four times and pauses	<p>The sbRIO-9627 is in safe mode. The software has crashed twice without rebooting or cycling power between crashes.</p>
Continuously blinks	<p>The sbRIO-9627 has not booted into NI Linux Real-Time. The sbRIO-9627 either booted into an unsupported operating system, was interrupted during the boot process, or detected an unrecoverable software error.</p>
On momentarily	<p>The sbRIO-9627 is booting. No action required.</p>
Off	<p>The sbRIO-9627 is in run mode. Software is installed and the operating system is running.</p>

## User LEDs

You can define the USER1 and USER FPGA1 LEDs to meet the needs of your application. The following table lists the USER1 and USER FPGA1 LED indicators.

**Table 14. User LEDs**

LED	LED Color	Description
USER1	Green	Use LabVIEW Real-Time to define the USER1 LED with the RT LEDs VI. For more information about the RT LEDs VI, refer to the <i>LabVIEW Help</i> .
USER FPGA1	Green	Use the LabVIEW FPGA Module and NI-RIO Device Drivers software to define the USER FPGA1 LED. Use the USER FPGA1 LED to help debug your application or retrieve application status. Refer to the <i>LabVIEW Help</i> for information about programming this LED.

## Ethernet LED Indicators

The following table lists the Ethernet LED indicators.

**Table 15. Ethernet LED Indicators**

LED	LED Color	LED Pattern	Indication
ACT/LINK	—	Off	LAN link not established
	Green	Solid	LAN link established
		Flashing	Activity on LAN
10/100/1000	Yellow	Solid	1,000 Mbit/s data rate selected
	Green	Solid	100 Mbit/s data rate selected
	—	Off	10 Mbit/s data rate selected

## Real-Time Clock (RTC) Battery

The sbRIO-9627 contains an RTC battery, which is a lithium cell battery that stores the system clock information when the sbRIO-9627 is powered off. Only a slight drain on the RTC battery occurs when power is applied to the sbRIO-9627 power connector. The rate at which the RTC battery drains when power is disconnected depends on the ambient storage temperature. For longer battery life, store the sbRIO-9627 at a cooler temperature and apply power to the power connector. Refer to the device specifications on [ni.com/manuals](http://ni.com/manuals) for the expected battery lifetime.

If longer battery life is needed, attach an RTC battery on the RMC and connect it to the VBAT pin. Refer to the [RMC VBAT](#) section in this document for more information.

The battery is user-replaceable. The sbRIO-9627 ships with an industrial-rated BR1225 battery from RAYOVAC.

# Internal Real-Time Clock (RTC)

The system clock of the NI sbRIO device gets the date and time from the internal RTC at startup. This synchronization provides timestamp data to the device.

## RIO Mezzanine Card Connector

The following figure shows the dimensions of an example RMC and the locations for connecting to the NI sbRIO device.

**Figure 22.** RMC Connector Location and Dimensions on Example RMC

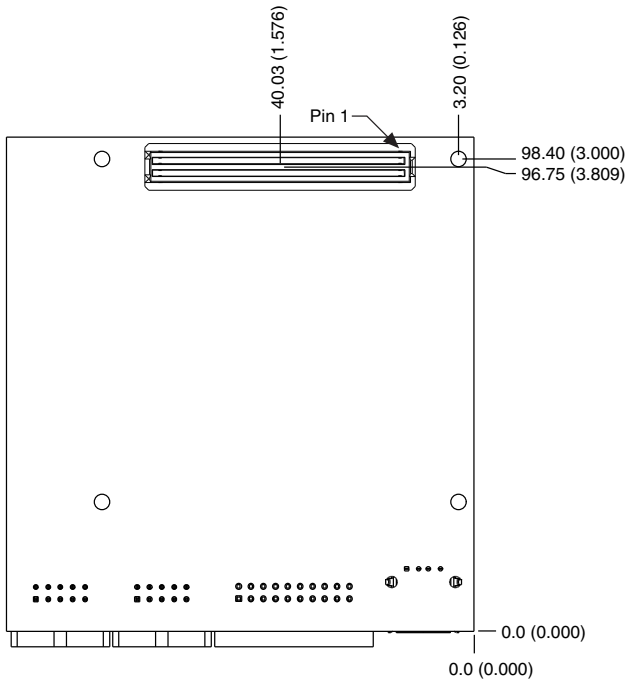

**Caution** RMCs are not hot-swappable. Disconnect power before mating or unmating.



# RMC Connector Pins

The pins on the RMC connector are divided into the following groups:

- Pins with dedicated functions.
- General purpose digital I/O pins.
- Pins reserved for future use.



**Note** Leave reserved and unused pins disconnected on RMCs.

# Pins with Dedicated Functions

**Table 16.** RMC Connector Pins with Dedicated Functions

Pin Group	Pin Name	Direction (from Host System)	I/O Standard	Description
Power	GND	O	—	Digital ground from the RMC connector host system.
	3.3 V_AUX	O	—	3.3 V_AUX from the RMC connector host system. The rail is always on when the main host system is connected to power.
	5 V	O	—	5 V from the RMC connector host system.
	FPGA_VIO	O	—	I/O voltage for the FPGA <sub>3,3V</sub> pins.
	VIN_FILTERED	I	—	9 V to 30 V input to power the device through the RMC connector rather than through the front panel connector.
	VBAT	I	—	This pin may be used to connect a longer life battery to the RTC on the host system. The RTC will track absolute time as long as either the main system battery or RMC battery through VBAT pin contains sufficient charge.

**Table 16. RMC Connector Pins with Dedicated Functions (Continued)**

Pin Group	Pin Name	Direction (from Host System)	I/O Standard	Description
C Series DIO	ID_SELECT#[x] OSCLK_DIO0[x] TRIG_DIO1[x] DONE#_DIO2[x] CVRT#_DIO3[x] SPIFUNC_DIO4[x] SPICS#_DIO5[x] MISO_DIO6[x] MOSI_DIO7[x] SPI_CLK[x]	I/O	LVTTL <sub>3.3V</sub> LVTTL <sub>5V</sub> tolerant input	Signal conditioned C Series DIO.  Refer to the <i>NI sbRIO-9607/9627 RMC Design Guide</i> for more information about how to use these signals to connect up to two board-level C Series modules to your RMC.
	SLEEP 5V C Series	O	5 V	
Resets	RST#	O	LVTTL <sub>3.3V</sub>	Reset that indicates that the main power is not ideal, or that the RMC connector host system has been reset.
	SYS_RST#	I	LVTTL <sub>3.3V</sub>	System reset used to reset the RMC connector host system. Asserting this pin causes the RST# pin to also assert.

**Table 16. RMC Connector Pins with Dedicated Functions (Continued)**

Pin Group	Pin Name	Direction (from Host System)	I/O Standard	Description
GBE (after PHY)	GBE_MDI0+ GBE_MDI0- GBE_MDI1+ GBE_MDI1- GBE_MDI2+ GBE_MDI2- GBE_MDI3+ GBE_MDI3-	I/O	Defined by Ethernet PHY specification	Pre-magnetic Gigabit Ethernet data pairs.
	GBE_SPEED_LEDg GBE_SPEED_LEDy	O	LVTTL <sub>3.3V</sub>	Speed LED signals.
	GBE_ACT_LEDg	O	LVTTL <sub>3.3V</sub>	Activity/link LED signal.
High speed USB (after PHY)	USB_D+ USB_D-	I/O	Defined by USB	Port for hi-speed differential USB.
	USB_MODE	I	—	Connect to digital ground or leave disconnected to configure the USB port as Host.  Connect to +3.3V to configure the USB port as Device.
	USB_CPEN	O	LVTTL <sub>3.3V</sub>	Refer to the <i>sbRIO-9607/9627 RMC Design Guide</i> for more information about these signals.
	USB_VBUS	I	—	

## General Purpose Digital I/O Pins

**Table 17.** RMC Connector General Purpose Digital I/O Pins







Pin Group	Pin Name	Direction (from Host System)	I/O Standard	Description
General purpose digital I/O pins	DIO[0..95]	I/O	LVTTL <sub>3.3V</sub>	Pins for connecting directly to the FPGA through a series resistor and for enabling serial, CAN, or SDHC peripherals on an RMC.

## RMC Connector Pin Listing by Location

The following table lists the pinout for the RMC connector and indicates the pin number and corresponding function.

**Figure 23. RMC Connector Pin Listing**

1 - VIN_Filtered	2 - GND	3 - GBE_MDI0+	4 - GND	5 - GBE_MDI2+	6 - GND
7 - VIN_Filtered	8 - GND	9 - GBE_MDI0-	10 - GND	11 - GBE_MDI2-	12 - GND
13 - GND	14 - VIN_Filtered	15 - GND	16 - GBE_MDI1+	17 - GND	18 - GBE_MDI3+
19 - GND	20 - VIN_Filtered	21 - GND	22 - GBE_MDI1-	23 - GND	24 - GBE_MDI3-
25 - RESERVED	26 - GND	27 - RESERVED	28 - GND	29 - USB_D+	30 - GND
31 - GBE_SPEED_LEDy	32 - GBE_ACT_LEDg	33 - USB_CPEN	34 - USB_MODE	35 - USB_D-	36 - GND
37 - GBE_SPEED_LEDg	38 - RST#	39 - GND	40 - ID_SELECT#[1]	41 - GND	42 - RESERVED
43 - SYS_RST#	44 - GND	45 - SLEEP[1]	46 - CVRT#_DIO3[1]	47 - GND	48 - 3.3V_AUX
49 - GND	50 - DONE#_DIO2[1]	51 - SLEEP[2]	52 - GND	53 - SPIFUNC_DIO4[1]	54 - 5V
55 - SPICS#_DIO5[1]	56 - MOSI_DIO7[1]	57 - GND	58 - OSCLK_DIO0[1]	59 - RESERVED	60 - 5V
61 - SPI_CLK[1]	62 - GND	63 - ID_SELECT#[2]	64 - TRIG_DIO1[1]	65 - GND	66 - 5V
67 - GND	68 - DONE#_DIO2[2]	69 - CVRT#_DIO3[2]	70 - GND	71 - MISO_DIO6[1]	72 - 5V
73 - SPICS#_DIO5[2]	74 - MOSI_DIO7[2]	75 - GND	76 - OSCLK_DIO0[2]	77 - SPIFUNC_DIO4[2]	78 - GND
79 - SPI_CLK[2]	80 - GND	81 - MISO_DIO6[2]	82 - TRIG_DIO1[2]	83 - GND	84 - USB_VBUS
85 - GND	86 - 5V C Series	87 - RESERVED	88 - GND	89 - DIO47	90 - DIO15
91 - 5V C Series	92 - DIO63	93 - GND	94 - DIO79	95 - DIO46	96 - GND
97 - DIO95	98 - GND	99 - DIO31	100 - DIO78	101 - GND	102 - DIO14
103 - GND	104 - DIO62	105 - DIO30	106 - GND	107 - DIO45	108 - DIO13
109 - DIO94	110 - DIO61	111 - GND	112 - DIO77	113 - DIO44	114 - GND
115 - DIO93	116 - GND	117 - DIO29	118 - DIO76	119 - GND	120 - DIO12
121 - GND	122 - DIO60	123 - DIO28	124 - GND	125 - DIO43	126 - DIO11
127 - DIO92	128 - DIO59	129 - GND	130 - DIO75	131 - DIO42	132 - GND
133 - DIO91	134 - GND	135 - DIO27	136 - DIO74	137 - GND	138 - DIO10
139 - GND	140 - DIO58	141 - DIO26	142 - GND	143 - DIO41	144 - DIO9
145 - DIO90	146 - DIO57	147 - GND	148 - DIO73	149 - DIO40	150 - GND
151 - DIO89	152 - GND	153 - DIO25	154 - DIO72	155 - GND	156 - DIO8
157 - GND	158 - DIO56	159 - DIO24	160 - GND	161 - DIO39	162 - DIO7
163 - DIO88	164 - DIO55	165 - GND	166 - DIO71	167 - DIO38	168 - GND
169 - DIO87	170 - GND	171 - DIO23	172 - DIO70	173 - GND	174 - DIO6
175 - GND	176 - DIO54	177 - DIO22	178 - GND	179 - DIO37	180 - DIO5
181 - DIO86	182 - DIO53	183 - GND	184 - DIO69	185 - DIO36	186 - GND
187 - DIO85	188 - GND	189 - DIO21	190 - DIO68	191 - GND	192 - DIO4
193 - GND	194 - DIO52	195 - DIO20	196 - GND	197 - DIO35	198 - DIO3
199 - DIO84	200 - DIO51	201 - GND	202 - DIO67	203 - DIO34	204 - GND
205 - DIO83	206 - GND	207 - DIO19	208 - DIO66	209 - GND	210 - DIO2
211 - GND	212 - DIO50	213 - DIO18	214 - GND	215 - DIO33	216 - DIO1
217 - DIO82	218 - DIO49	219 - GND	220 - DIO65	221 - DIO32	222 - GND
223 - DIO81	224 - GND	225 - DIO17	226 - DIO64	227 - GND	228 - DIO0
229 - GND	230 - DIO48	231 - DIO16	232 - GND	233 - RESERVED	234 - FPGA_VIO
235 - DIO80	236 - VBAT	237 - GND	238 - RESERVED	239 - FPGA_CONF	240 - FPGA_VIO

 Power	 Differential IO	 Reserved
 GND	 Singled Ended IO	 Routed to FPGA Global Clock Resources on the Host System

Use the following table to determine if a previously designed RMC is compatible with the new RMC pinout and as guidance on how to design an RMC for compatibility with future generations of the RMC.

**Table 18. RMC Connector Feature Set Compatibility**

<b>Feature Set</b>	<b>sbRIO-9605/06/23/26</b>	<b>sbRIO-9627</b>	<b>Future Design Compatibility</b>
DIO[0..63]	Yes	Yes	Yes
DIO[64..95]	Yes	Yes	Not guaranteed
FPGA_CONF	Yes	Yes	Yes
USB_D+/-	Yes	Yes	Yes
RST#	Yes	Yes	Yes
SYS_RST#	Yes	Yes	Yes
5V	Yes	Yes	Yes
3.3V_AUX	Yes	Yes	Yes
FPGA_VIO	Yes	Yes	Yes
PROC_VIO	Yes	No <sup>1</sup>	Not guaranteed
VBAT	Yes	Yes	Yes
GP_PORT CAN RS-232 RS-485 Secondary Ethernet SDHC	Yes	No	Not guaranteed
Processor I/O via DIO[0..95] CAN RS-232 RS-485 SDHC	No	Yes	Not guaranteed

<sup>1</sup> Pin 42 - RESERVED of the RMC connector provides 3.3 V to the RMC in order to maintain compatibility with the sbRIO-9605/06/23/26 RMC pinout. This pin is not recommended for use with new designs.

**Table 18.** RMC Connector Feature Set Compatibility (Continued)

Feature Set	sbRIO-9605/06/23/26	sbRIO-9627	Future Design Compatibility
GBE_MDI[0..3+/-]	No	Yes	Not guaranteed
USB_MODE, USB_CPEN, USB_VBUS	No	Yes	Not guaranteed
Dedicated C Series DIO	No <sup>2</sup>	Yes	Not guaranteed
VIN_FILTERED	No	Yes	Yes

## RMC Connector Power Requirements

Use the following voltage pins to power the RMC:

- 5 V rail (pins 54, 60, 66, and 72), which provides a primary power source to the RMC
- 3.3 V\_AUX (pin 48), which provides an auxiliary power source to the RMC
- FPGA\_VIO (pins 234 and 240), which provides I/O power for the FPGA I/O pins

The following table lists the requirements for each rail on an RMC connector.

Rail	Voltage Tolerance	Maximum Current	Maximum Ripple and Noise
5 V	± 5%	1.5 A	50 mV
3.3V_AUX	± 5%	0.33 A	50 mV
FPGA_VIO (3.3 V)	± 5%	0.33 A	50 mV



**Caution** Ensure that your RMC does not source any current onto any of the power pins and can tolerate 5 V and FPGA\_VIO coming up in any order.

## RMC Connector Electrical Characteristics

Each pin in an RMC connector conforms to a particular I/O standard. On the sbRIO-9627, the LVTTTL<sub>3.3V</sub> I/O standard meets the input and output logic levels defined in the *NI sbRIO-9627 Specifications* on [ni.com/manuals](http://ni.com/manuals).

RMCs with FPGA I/O pins that require an explicit pull-up or pull-down should use the values listed in the following table.

<sup>2</sup> The sbRIO-9605/06/23/26 supports C Series I/O using the NI 9693.



**Table 19.** Explicit Pull-up/-down Values

Requirement	Maximum Value	Minimum Value
Explicit pull-up	14.7 k $\Omega$	1 k $\Omega$
Explicit pull-down	8 k $\Omega$	1 k $\Omega$

## VIN\_Filtered

The sbRIO-9627 may alternatively be powered over the RMC connector via the VIN\_Filtered pins. These input pins are 9 V to 30 V. These power pins must contain appropriate filtering on them to ensure reliable operation of the sbRIO-9627. Refer to the *sbRIO-9607/9627 RMC Design Guide* on [ni.com/manuals](http://ni.com/manuals) for further information.



**Note** If simultaneously connected to multiple power sources, the sbRIO-9627 draws power from the terminal with the higher voltage. Ensure that the preferred power supply is 500 mV higher than the alternative power supply.

## RMC VBAT

The NI sbRIO device implements an onboard RTC to keep track of absolute time. The RMC connector provides a VBAT pin to power the RTC. The sbRIO-9627 also has an onboard battery that powers the RTC. The following table lists the VBAT power specifications.

**Table 20.** VBAT Power Specifications

Specification	Minimum	Typical	Maximum
VBAT input voltage	2.875 V	3.0 V	5.5 V
sbRIO-9627 powered VBAT current	—	25 nA	100 nA
sbRIO-9627 unpowered VBAT current	—	2.6 $\mu$ A average	4.2 $\mu$ A average

## USB Support

The USB interface supports both host mode and device mode USB. The USB pairs connect to either a USB connector or to a USB device on the RMC board. The *NI sbRIO-9607/9627 RMC Design Guide* on [ni.com/manuals](http://ni.com/manuals) provides design guidelines, requirements for routing signals, and recommendations for an appropriate connector. The following specifications depend on a suitable RMC design that follows these guidelines and requirements.

Number of RMC USB ports

Host/Device	1
USB interface	USB 2.0, Hi-Speed
Maximum data rate	480 Mb/s per interface

# RMC Ethernet Support

You must connect this interface to voltage-mode-PHY-compatible Ethernet magnetics. The *NI sbRIO-9607/9627 RMC Design Guide* on [ni.com/manuals](http://ni.com/manuals) provides design guidelines, requirements for routing signals, and recommendations for appropriate magnetics and connectors. The following specifications depend on a suitable RMC board design that follows these guidelines and requirements.

Network interface	10Base-T, 100Base-TX, 1000Base-T Ethernet
Compatibility	IEEE 802.3
Communication rates	10 Mbps, 100 Mbps, 1,000 Mbps auto-negotiated, half-/full-duplex

## RMC Ethernet LED Behavior

The RMC connector provides signals for implementing Ethernet LEDs on an RMC.

The GBE\_ACT\_LEDg signal indicates the link status and activity of the Ethernet connection, as described in the following table.

**Table 21.** Ethernet Link Activity LED Behavior

Link State	GBE_ACT_LEDg Behavior
No link	Low
Link, but no activity	High
Link with activity	Toggleing

The GBE\_SPEED\_LEDg and GBE\_SPEED\_LEDy signals indicate the link speed of the Ethernet connection, as described in the following table.

**Table 22.** Ethernet Speed LED Behavior

Link Speed	GBE_SPEED_LEDg	GBE_SPEED_LEDy
No link	Low	Low
10Base-T	Low	Low
100Base-TX	High	Low
1000Base-T	Low	High

## C Series DIO

The C Series DIO lines provides up to two slots of C Series support on the RMC. All lines can be connected directly to the 15-pin DSUB connector except for the 5 V power. The 5 V power

has specific filtering requirements. The *NI sbRIO-9607/9627 RMC Design Guide* on [ni.com/manuals](https://ni.com/manuals) provides design guidelines, requirements for routing signals, requirements for the 5 V filtering, and recommendations for an appropriate connector.

## RMC RST#

The RST# pin indicates that power provided through the RMC Connector is valid or that the sbRIO-9627 is in reset. The signal goes to 3.3 V if the power is valid when the board powers up or when coming out of reset. The signal asserts to 0 V for at least 1 ms before returning to 3.3 V when going into reset. This includes the RMC Connector, traces, vias, and device pins. Refer to the *NI sbRIO-9627 Specifications* on [ni.com/manuals](https://ni.com/manuals) for output logic levels.

## SYS RST#

The SYS\_RST# signal is a system reset signal for resetting the sbRIO-9627 processor and FPGA. Asserting this signal causes the RMC RST# signal to also assert. The SYS\_RST# signal asserts low.

The amount of time for which you assert this signal determines the specific reset behavior. This behavior is the same as shown in the [Reset Button Behavior](#) section of this document.

You can assert the SYS\_RST# signal before you apply power to the sbRIO-9627. The sbRIO-9627 remains in reset until the SYS\_RST# signal de-asserts. If you assert the SYS\_RST# signal before power is applied, then you must de-assert the SYS\_RST# signal within five seconds.

## FPGA\_CONF

The FPGA\_CONF pin asserts high when the FPGA has been programmed. When the FPGA is not configured the signal may be either floating or driven low. A pull-down resistor is required when using this signal to ensure it returns to ground.

## User-Defined FPGA Signals

The RMC connector provides FPGA Digital I/O (DIO) pins that you configure for purposes specific to your application. You can use these signals to implement the following interfaces:

- FPGA DIO
- Additional UART (4 RS-232 and 2 RS-485) Support
- CAN Support
- SDIO Support

Use one of the following methods to access the user-defined FPGA signals in LabVIEW:

- Right-click your **FPGA Target** and select **New»RIO Mezzanine Card...** to choose a generic Digital RMC and access all 96 DIO lines with digital I/O nodes.



**Note** This methodology does not allow you to configure the DIO lines as processor peripherals such as CAN, SDIO, or Serial.

- 1. Right click your **FPGA Target** and select **Launch sbRIO CLIP Generator...** to launch the NI Single-Board RIO CLIP Generator application, which you can use to create a socketed component-level IP (CLIP) that defines the FPGA signals or processor peripherals to use in your application.
  2. After you create a CLIP, return to LabVIEW and right-click an **RMC Socket** under the **FPGA Target** and select **Properties**.
  3. In the Socket Properties dialog box, select your CLIP and click OK. The I/O appears under the socket, or the I/O is connected directly to the RT processor.



**Note** For a given FPGA target, you must use either the digital I/O method or the socketed CLIP method for all 96 DIO lines.

## FPGA DIO

**Figure 24.** Circuitry of One 3.3 V DIO Channel on the RMC Connector



The RMC has a total of 96 DIO channels. The NI sbRIO device is tested with all DIO channels driving  $\pm 3$  mA DC loads. DIO signals are tristated (floating) before and during FPGA configuration. After FPGA configuration completes, unused DIO signals remain tristated. To ensure startup values, place pull-up or pull-down resistors on an RMC. The DIO channels on the NI sbRIO device are routed with a 55  $\Omega$  characteristic trace impedance. Route all RMCs with a similar impedance to ensure the best signal quality. Refer to *3.3 V Digital I/O on RMC Connector* section in the *NI sbRIO-9627 Specifications* on [ni.com/manuals](http://ni.com/manuals) for the logic levels.



**Note** Refer to the *NI sbRIO-9607/9627 RMC Design Guide* on [ni.com/manuals](http://ni.com/manuals) for information about FPGA DIO best practices.

## FPGA DIO Clock Capabilities

- Single-region clock capable (SRCC)—These pins provide a direct connection to the global clock distribution buffers in the FPGA. The pins also connect to the regional buffers on a specific bank of pins. Each SRCC pin has an `_SRCC` suffix in the pin name.
- Multi-region clock capable (MRCC)—These pins provide a direct connection to the global clock distribution buffers in the FPGA. The pins also connect to the regional and

multi-regional buffers on a specific bank of pins. Each MRCC pin has an `_MRCC` suffix in the pin name.



**Tip** FPGA DIO pins through the RMC may be used to import or export clocks. Use the CLIP generation wizard to configure DIO lines for this capability. NI recommends that you use the SRCC or MRCC pins when you import a clock into LabVIEW FPGA.

## Additional UART (4 RS-232 and 2 RS-485) Support

You must connect each of these interfaces to an appropriate RS-232 or RS-485 serial transceiver on your RMC design. The *NI sbRIO-9607/9627 RMC Design Guide* on [ni.com/manuals](https://ni.com/manuals) provides design guidelines, requirements for routing signals, and recommendations for a serial transceiver. The specifications depend on a suitable RMC design that follows these guidelines, requirements, and recommended or equivalent transceivers. Refer to *RS-232 (DTE) Serial Port* and *RS-485 Serial Port* section in the *NI sbRIO-9627 Specifications* on [ni.com/manuals](https://ni.com/manuals) for the specifications.

## CAN Support

You must connect this interface to an appropriate CAN transceiver on your RMC design. The *NI sbRIO-9607/9627 RMC Design Guide* on [ni.com/manuals](https://ni.com/manuals) provides design guidelines, requirements for routing signals, and recommendations for a CAN transceiver. The specifications depend on a suitable RMC design that follows these guidelines and requirements and utilizes the recommended or an equivalent transceiver. Refer to *Embedded CAN* section in the *NI sbRIO-9627 Specifications* on [ni.com/manuals](https://ni.com/manuals) for the specifications.

## SDIO Support

The sbRIO-9627 RMC provides a Secure Digital (SD) Card interface. The *NI sbRIO-9607/9627 RMC Design Guide* on [ni.com/manuals](https://ni.com/manuals) provides design guidelines, requirements for routing signals, requirements for pull-up resistors, and recommendations for an appropriate connector. Refer to *SD Card Slot* in the *NI sbRIO-9627 Specifications* on [ni.com/manuals](https://ni.com/manuals) for the specifications.

## Integrated 3.3 V Digital I/O

The NI sbRIO device provides 3.3 V output, 5 V tolerant input digital I/O via the 50-pin IDC headers.

The following figure shows the circuitry of one 3.3 V DIO channel on the J5 IDC header.

**Figure 25.** Circuitry of One 3.3 V DIO Channel on the J5 IDC Header

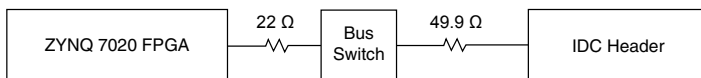

The NI sbRIO device is tested with all DIO channels driving  $\pm 3$  mA DC loads. DIO signals are tristated (floating) before and during FPGA configuration. After FPGA configuration completes, unused DIO signals remain tristated. Refer to *3.3 V Digital I/O on 50-Pin IDC Connector* section in the *NI sbRIO-9627 Specifications* on [ni.com/manuals](http://ni.com/manuals) for the logic levels.

## Integrated Analog Input

The sbRIO-9627 has 16 multiplexed,  $\pm 10$  V, single-ended or eight differential, 16-bit AI channels. Connector J5, the MIO connector, provides connections for analog inputs, outputs, and grounds.

**Figure 26.** Single-Ended Analog Input

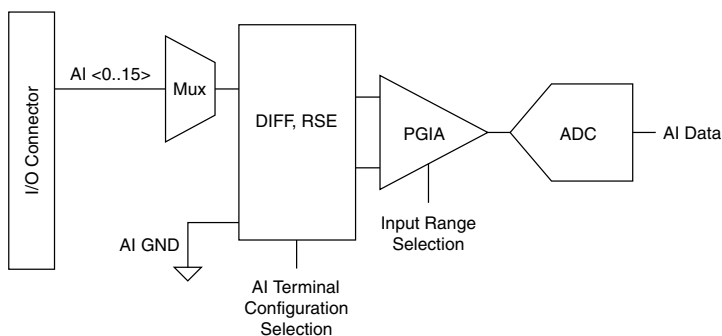

## Analog Input Range

An input range is a set of input voltages that an analog input channel can digitize with the specified accuracy. NI sbRIO devices with selectable input ranges have a programmable gain instrumentation amplifier (PGIA), which amplifies or attenuates the AI signal depending on the input range. You can program the input range for each AI channel independently on the sbRIO-9627.

The ADC converts analog inputs into discrete digital values. For a 16-bit ADC there are  $2^{16}$  (65,536) possible values. These values are spread evenly across the input range, and the voltage difference between values is proportional to the input range selected for the channel. The voltage difference between values is the size of the least significant bit (LSB size) for the channel. The following equation shows how to calculate the LSB size for a channel set to the -10 V to 10 V input range with a 16-bit ADC.

$$\frac{10V - (-10V)}{65,536} = 35\mu V$$

The sbRIO-9627 uses a scaling method that requires some ADC codes (typically about 5% of the codes) to lie outside the specified range. This method improves absolute accuracy, but it increases the LSB size by about 5% over the calculated value.

Choose an input range that matches the expected range of your input signal. A large input range accommodates large variations in signals but results in a larger LSB and, therefore, lower resolution. A smaller input range improves the resolution, but large input signals may go out of range.

For more information about selecting ranges, refer to the *LabVIEW Help*.

The following table shows the input ranges and resulting LSB sizes for AI channels on each NI sbRIO device.

**Table 23.** NI sbRIO Device Input Range and Resolutions

Input Range	Bit Resolution	LSB Size (includes 5% Overranging)
-10 V to 10 V	16-bit	320 $\mu$ V
-5 V to 5 V		160 $\mu$ V
-2 V to 2 V		64 $\mu$ V
-1 V to 1 V		32 $\mu$ V

## Working Voltage Range

The PGIA on NI sbRIO devices operates normally by amplifying signals of interest while rejecting common-mode signals under the following three conditions:

- The common-mode voltage ( $V_{cm}$ ), which is equivalent to subtracting AIGND from AI-, must be less than  $\pm 10$  V.  $V_{cm}$  is a constant for all range selections.
- The signal voltage ( $V_s$ ), which is equivalent to subtracting AI+ from AI-, must be less than or equal to the range selection of the given channel. If  $V_s$  is greater than the range selected, the signal clips and information is lost.
- The total working voltage of the positive input, which is equivalent to  $(V_{cm} + V_s)$ , or subtracting AIGND from AI+, must be less than the maximum working voltage specified for that range. Refer to the *NI sbRIO-9627 Specifications* on [ni.com/manuals](http://ni.com/manuals) for the maximum working voltage for each range.

If any of these conditions are exceeded, the input voltage is clamped until the fault condition is removed.

## Best Practices for Scanning Multiple Channels

NI sbRIO devices can scan multiple channels at high rates and digitize the signals accurately. If your application scans multiple channels, settling error can affect the accuracy of your measurements. Settling error is a difference between the input value and the value that the ADC digitizes, and is the result of switching between multiplexed input channels. NI defines settling error as the difference between a single-channel measurement of a signal and a multiple-channel measurement of the same signal. Settling errors are directly proportional to channel-to-channel voltage step size and the time between acquisitions. NI sbRIO devices scan at a fixed rate equal to the maximum aggregate rate.

To ensure the lowest possible settling errors, design your application according to the following best practices:

- Use low-impedance sources—Ensure that the impedance of signal sources is less than 1 k $\Omega$ . High-impedance sources increase settling errors and decrease accuracy at fast scanning rates. You can reduce impedance by connecting a voltage-follower circuit between the signal source and the AI pin of the channel. For more information about reducing impedance, visit [ni.com/info](http://ni.com/info) and entering the Info Code `rdbbis`.
- Use short, high-quality cabling—Using short, high-quality cables can minimize several effects that degrade accuracy, including crosstalk, transmission line effects, and noise. The capacitance of the cable can also increase the settling error. NI recommends using individually shielded twisted-pair wires shorter than 2 m to connect AI signals to the device. Refer to the [Connecting Analog Input Signals](#) section for more information.
- Minimize voltage step between adjacent channels—Settling error increases with the voltage step between channels. If you know the expected input ranges of your signals, you can group signals with similar expected ranges together on adjacent channels.



**Note** When you program your I/O node with a scan list, the NI sbRIO device scans channels in numerical order at a fixed rate. Calling a second I/O node adds an extra delay before the first channel but does not reduce settling error.

## Differential Measurement Configurations

To attain more accurate measurements and less noise on the sbRIO-9627, use a differential measurement configuration. A differential measurement configuration requires two inputs for each measurement, reducing the number of available channels from 16 to eight. The following table shows the signal pairs that are valid for differential connection configurations.

**Table 24.** Differential Analog Input Signals

Channel	Signal +	Signal -
0	AI0	AI8
1	AI1	AI9
2	AI2	AI10
3	AI3	AI11
4	AI4	AI12
5	AI5	AI13
6	AI6	AI14
7	AI7	AI15

The following figure shows how to make a differential connection for a floating signal and for a ground-referenced signal.



**Figure 27. Differential Connections with Floating and Grounded Signal Sources**

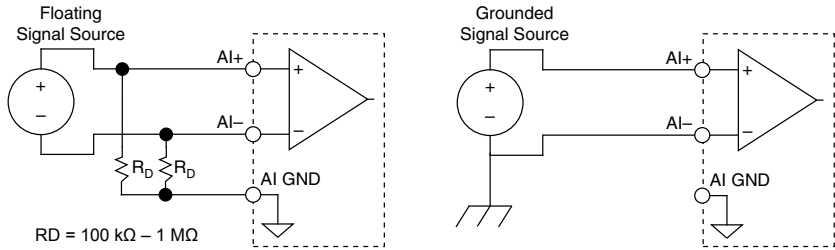

## Connecting Analog Input Signals

The following table summarizes the recommended input configuration for both types of signal sources.

**Table 25. NI sbRIO Analog Input Configuration**

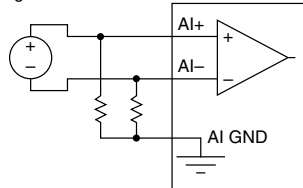
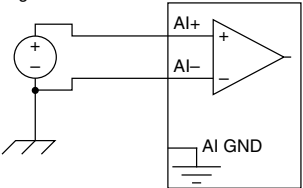
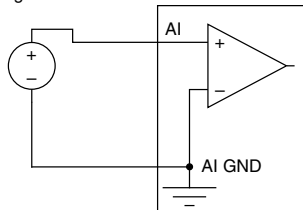
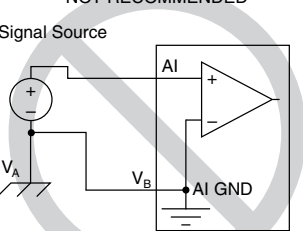
AI Ground-Reference Setting	Floating Signal Sources (Not Connected to Building Ground)	Ground-Referenced Signal Sources
Examples	<ul style="list-style-type: none"> <li>• Ungrounded thermocouples</li> <li>• Signal conditioning with isolated outputs</li> <li>• Battery devices</li> </ul>	<ul style="list-style-type: none"> <li>• Plug-in instruments with non-isolated outputs</li> </ul>
Differential	<p>Signal Source</p> 	<p>Signal Source</p> 
Referenced Single-Ended (RSE)	<p>Signal Source</p> 	<p><b>NOT RECOMMENDED</b></p> <p>Signal Source</p>  <p>Ground-loop potential (<math>V_A - V_B</math>) are added to measured signal.</p>

## Connecting Floating Signal Sources

A floating signal source is not connected to the building ground system, but has an isolated ground-reference point. Some examples of floating signal sources are outputs of transformers, thermocouples, battery-powered devices, optical isolators, and isolation amplifiers. An instrument or device that has an isolated output is a floating signal source.

### When to Use Differential Connections with Floating Signal Sources

Use DIFF input connections for any channel that meets any of the following conditions:

- The input signal is low level (less than 1 V).
- The leads connecting the signal to the device are greater than 3 m (10 ft).
- The input signal requires a separate ground-reference point or return signal.

- The signal leads travel through noisy environments.
- Two analog input channels, AI+ and AI-, are available for the signal.

DIFF signal connections reduce noise pickup and increase common-mode noise rejection. DIFF signal connections also allow input signals to float within the common-mode limits of the PGIA.

## When to Use Referenced Single-Ended (RSE) Connections with Floating Signal Sources

Only use RSE input connections if the input signal meets the following conditions:

- The input signal can share a common reference point, AI GND, with other signals that use RSE.
- The input signal is high-level (greater than 1 V).
- The leads connecting the signal to the device are less than 3 m (10 ft).

DIFF input connections are recommended for greater signal integrity for any input signal that does not meet the preceding conditions.

In the single-ended modes, more electrostatic and magnetic noise couples into the signal connections than in DIFF configurations. The coupling is the result of differences in the signal path. Magnetic coupling is proportional to the area between the two signal conductors. Electrical coupling is a function of how much the electric field differs between the two conductors.

With this type of connection, the NI sbRIO device rejects both the common-mode noise in the signal and the ground potential difference between the signal source and the device ground.

## Using Differential Connections for Floating Signal Sources

You must connect the negative lead of a floating source to AI GND (either directly or through a bias resistor). Otherwise, the source may float out of the maximum working voltage range of the PGIA device and return erroneous data.

The preferred method for referencing the source to AI GND is to connect the positive side of the signal to AI+ and connect the negative side of the signal to AI GND as well as to AI- without using resistors, as shown in the following figure. This connection works well for DC-coupled sources with source impedance less than 100  $\Omega$ .

**Figure 28.** Differential Connections for Floating Signal Sources without Bias Resistors

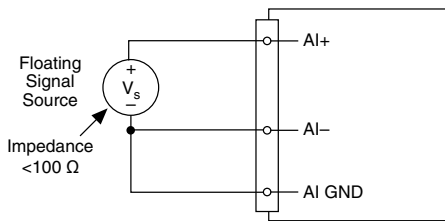

However, for larger source impedances, this connection leaves the DIFF signal path significantly off balance. Noise that couples electrostatically onto the positive signal does not

couple onto the negative signal because that signal is connected to ground. This noise appears as a differential mode signal instead of a common-mode signal, and thus appears in your data. In this case, instead of directly connecting the negative signal to AI GND, connect the negative signal to AI GND through a resistor that is about 100 times the equivalent source impedance, as shown in the following figure. The resistor puts the signal path nearly in balance, so that about the same amount of noise couples onto both connections, yielding better rejection of electrostatically coupled noise. This configuration does not load down the source (other than the very high input impedance of the PGIA).

**Figure 29.** Differential Connections for Floating Signal Sources with Single Bias Resistor

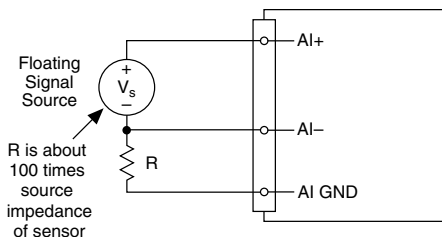

You can fully balance the signal path by connecting another resistor of the same value between the positive input and AI GND, as shown in the following figure. This fully balanced configuration offers slightly better noise rejection, but has the disadvantage of loading the source down with the series combination (sum) of the two resistors. If, for example, the source impedance is 2 k $\Omega$  and each of the two resistors is 100 k $\Omega$ , the resistors load down the source with 200 k $\Omega$  and produce a -1% gain error.

**Figure 30. Differential Connections for Floating Signal Sources with Balanced Bias Resistors**

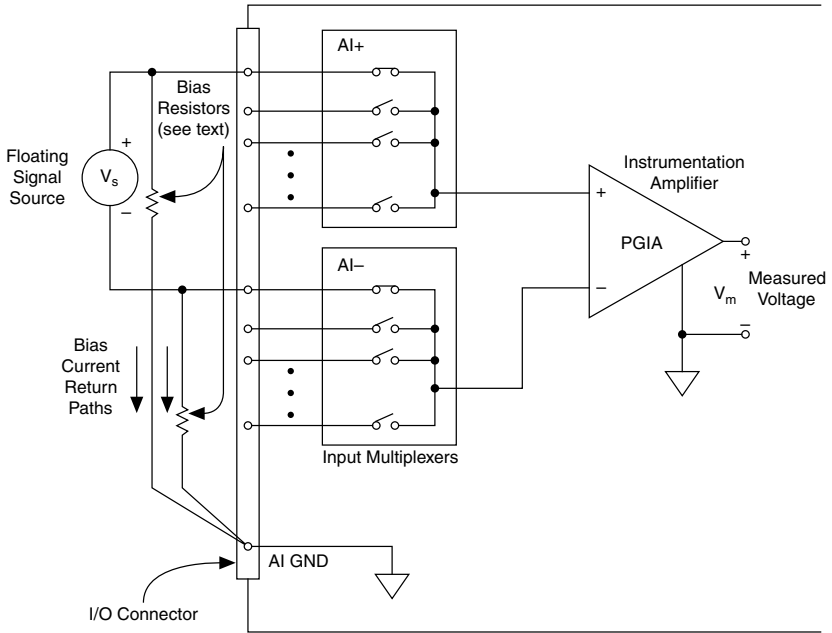

Both inputs of the PGIA require a DC path to ground in order for the PGIA to work. If the source is AC coupled (capacitively coupled), the PGIA needs a resistor between the positive input and  $AI\ GND$ . If the source has low-impedance, choose a resistor that is large enough not to significantly load the source but small enough not to produce significant input offset voltage as a result of input bias current (typically  $100\ k\Omega$  to  $1\ M\Omega$ ). In this case, connect the negative input directly to  $AI\ GND$ . If the source has high output impedance, balance the signal path as previously described using the same value resistor on both the positive and negative inputs. Some gain error will occur as a result of loading down the source, as shown in the following figure.

**Figure 31. Differential Connections for AC Coupled Floating Sources with Balanced**

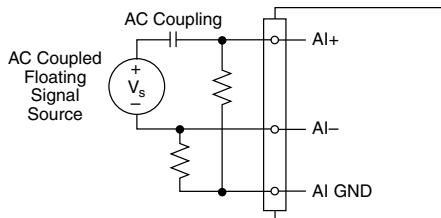

# Integrated Analog Output

The sbRIO-9627 has four 16-bit AO channels capable of driving  $\pm 10$  V. All AO channels are ground-referenced. Connector J5 provides connections for analog inputs, outputs, and grounds.

**Figure 32.** Analog Output Channel

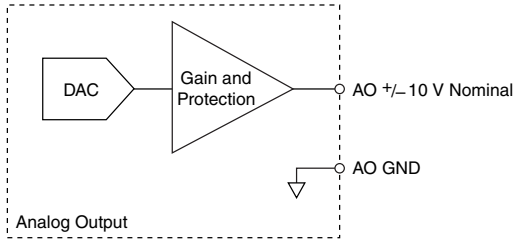

## Analog Output Startup and Initialization

The analog output on the NI sbRIO device does not get powered until the first time the FPGA is loaded after applying board power. The analog output is activated and initialized to 0 V the first time the FPGA is loaded with a bitfile in which either AI or AO functionality of the board is used. The AO is re-initialized to 0 V every time the FPGA is loaded with a bitfile containing AI or AO functionality.

## Power Requirements

The NI sbRIO device requires a 9 VDC to 30 VDC external power supply.

The NI sbRIO device filters and regulates the supplied power and provides power for RMCs.

## Wiring the Power Supply Connector

Wire the power supply connector as shown in the following figure.

**Figure 33. NI sbRIO Device Power Connector**

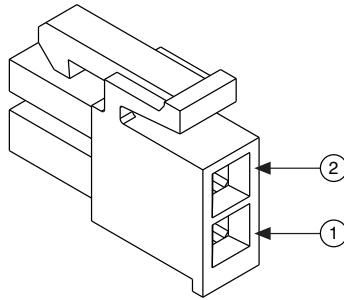

1. Connect V lead of the power supply.
2. Connect C lead of the power supply.



**Caution** Do not mate or unmate the power supply connectors while power is applied.

## Powering On the NI sbRIO Device

The NI sbRIO device runs a power-on self test (POST) when you apply power to the device. During the POST, the Power and Status LEDs turn on. When the Status LED turns off, the POST is complete. If the LEDs do not behave in this way when the system powers on, refer to the [STATUS LED Indicators](#) section of this document to help you troubleshoot the issue.

## Calculating the Power Requirement



**Caution** Exceeding the power limits may cause unpredictable device behavior.

Total power requirement =  $P_{\text{int}} + P_{\text{DIO}} + P_{5\text{V}} + P_{3.3\text{V}} + P_{\text{USB}} + P_{\text{SD}} + P_{\text{AO}}$ , where

$P_{\text{int}}$  is the power consumption by the NI sbRIO device internal operation, including integrated I/O functions

$P_{\text{DIO}}$  is the power consumption by the 3.3 V DIO pins across the RMC or DIO connectors

$P_{5\text{V}}$  is the power consumption by the 5 V voltage output across the RMC or DIO connectors

$P_{3.3\text{V}}$  is the power consumption by the 3.3 V voltage output across the RMC connector

$P_{\text{USB}}$  is the power consumption of a device plugged into the USB port

$P_{\text{SD}}$  is the power consumption of an SD card plugged into the SD slot

$P_{\text{AO}}$  is the power consumption of the Analog output across the MIO connector

When calculating each component of the maximum power consumption the following efficiency factors must be used:

$$\eta_{3.3V} \text{ and } \eta_{DIO} = 80\%$$

$$\eta_{5V} \text{ and } \eta_{USB} = 90\%$$

$$\eta_{AO} = 50\%$$



**Note** You must add 10% to the calculated or measured total power requirement to account for transient and startup conditions.

**Table 26.** Approximate Maximum Power Requirement

Power	Values and Calculations
Maximum $P_{\text{int}}$	11.81 W
Maximum $P_{\text{DIO}}$	Total DIO current $\times$ 3.3 V/0.8
Maximum $P_{5V}$	Total 5 V current $\times$ 5 V/0.9
Maximum $P_{3.3V}$	Total 3.3 V current $\times$ 3.3 V/0.8
Maximum $P_{\text{USB}}$	Total USB current $\times$ 5 V/0.9
Maximum $P_{\text{SD}}^3$	Total SD current $\times$ 3.3 V/0.8
Maximum $P_{\text{AO}}$	Total AO current $\times$ 15 V/0.5



**Note** These calculations are intended to approximate the maximum power requirements for an NI sbRIO device system. For a more accurate estimate of the power consumption of a specific application, NI recommends that you directly measure a board running the application in an environment representative of the intended use case.

<sup>3</sup> The SD specification allows 200 mA maximum current draw for an SD card. If your SD card does not specify maximum current draw, assume 200 mA.



# Configuring the sbRIO-9627

---

You can connect the sbRIO-9627 to a host computer or network and configure the startup options using the RJ-45 Gigabit Ethernet port. If a RIO Mezzanine Card is designed with a device USB connector, the target can also be configured using the device USB port.



**Tip** Refer to the *NI sbRIO-9627 Getting Started Guide* on [ni.com/manuals](https://ni.com/manuals) for basic configuration instructions and information about connecting to a host computer using the RJ-45 Gigabit Ethernet port.



**Tip** Refer to the *NI sbRIO-9607/9627 RMC Design Guide* on [ni.com/manuals](https://ni.com/manuals) for basic configuration instructions and information about connecting to a host computer using the device USB port.

## Connecting the sbRIO-9627 to the Host Computer

Complete the following steps to connect the sbRIO-9627 to the host computer using the RJ-45 Ethernet port.

1. Power on the host computer.
2. Connect the sbRIO-9627 to the host computer using a standard Category 5 (CAT-5) or better shielded, twisted-pair Ethernet cable.



**Caution** To prevent data loss and to maintain the integrity of your Ethernet installation, do not use a cable longer than 100 m.

The first time you power up the device, it attempts to initiate a DHCP network connection. If the device is unable to initiate a DHCP connection, it connects to the network with a link-local IP address with the form 169.254.x.x. After the device has powered up, you must install software on the device and configure the network settings in MAX.



**Note** Installing software may change the network behavior of the device. For information about network behavior by installed software version, visit [ni.com/info](https://ni.com/info) and enter the Info Code `ipconfigerio`.

## Finding the sbRIO-9627 on the Network (DHCP)

Complete the following steps to find the sbRIO-9627 on a network using DHCP.

1. Disable secondary network interfaces on the host computer, such as a wireless access card on a laptop.
2. Ensure that any anti-virus and firewall software running on the host computer allows connections to the host computer.



**Note** MAX uses UDP 44525. Refer to the documentation of your firewall software for information about configuring the firewall to allow communication through the UDP 44525.

3. Launch MAX on the host computer.

4. Expand **Remote Systems** in the configuration tree and locate your system.



**Tip** MAX lists the system under the model number followed by the serial number, such as NI-sbRIO-9627-#####.

## Finding the sbRIO-9627 on the Network (Static IP)

Complete the following steps to find the sbRIO-9627 on the network if the host computer is using a static IP address. The following instructions are for host computers running Microsoft Windows 7. For more information about performing the network configuration steps in this section, visit [www.microsoft.com](http://www.microsoft.com) and search for `change tcp/ip settings`.

1. Obtain IP settings from the host computer.
  - a) Click **Start**»**Control Panel**»**Network and Sharing Center**.
  - b) Select the primary network connection, which may appear as **Local Area Connection** or something similar.
  - c) In the dialog box that appears, click **Properties**.
  - d) Select **Internet Protocol Version 4 (TCP/IPv4)**.
  - e) Click **Properties**.
  - f) Record the **IP address**, **Subnet mask**, and **Default gateway** address. You need these settings to configure the network settings of the sbRIO-9627 and to restore the network settings of the host computer.



**Tip** You can also access these settings by opening the Start menu, entering `cmd.exe`, and entering `ipconfig` in the command window that launches.

- g) Wait at least one minute.
2. Configure IP Settings on the controller in MAX.
    - a) Launch MAX on the host computer.
    - b) Expand **Remote Systems** in the configuration tree and locate your system.



**Tip** MAX lists the system under the model number followed by the serial number, such as NI-sbRIO-9627-#####.

- c) Select the **Network Settings** tab near the bottom of the window.
- d) Select **Static** on the **Configure IPv4 Address** control.
- e) Enter values for **IPv4 Address**, **Subnet Mask**, **Gateway**, and **DNS Server** based on the information you recorded. Be sure to enter a value for **IPv4 Address** that is not used by another device on the network. For example, do not use the IP address usually assigned to the host computer.
- f) Click **Save** and let MAX restart the sbRIO-9627. The sbRIO-9627 disappears from under **Remote Systems** and does not reappear until you restore the original network settings to the host computer.
- g) Restore the original network settings to the host computer.
- h) Return to MAX and refresh **Remote Systems**.

## Configuring Startup Options

Complete the following steps to configure the sbRIO-9627 startup options in MAX.

1. In MAX, expand your system under Remote Systems.
2. Select the **Startup Settings** tab to configure the startup settings.

## sbRIO-9627 Startup Options

You can configure the following sbRIO-9627 startup options.

**Table 27.** sbRIO-9627 Startup Options

Startup Option	Description
Force Safe Mode	Rebooting the sbRIO-9627 with this setting on starts the sbRIO-9627 without launching LabVIEW Real-Time or any startup applications. In safe mode, the sbRIO-9627 launches only the services necessary for updating configuration and installing software.
Enable Console Out	Rebooting the sbRIO-9627 with this setting on redirects the console output to the RS-232 serial port. You can use a serial-port terminal program to read the IP address and firmware version of the sbRIO-9627. Use a null-modem cable to connect the RS-232 serial port to a computer. Make sure that the serial-port terminal program is configured to the following settings: <ul style="list-style-type: none"> <li>• 115,200 bits per second</li> <li>• Eight data bits</li> <li>• No parity</li> <li>• One stop bit</li> <li>• No flow control</li> </ul>
Disable RT Startup App	Rebooting the sbRIO-9627 with this setting on prevents any LabVIEW startup applications from running.
Disable FPGA Startup App	Rebooting the sbRIO-9627 with this setting on prevents autoloading of any FPGA application.
Enable Secure Shell (SSH) Logins	Rebooting the sbRIO-9627 with this setting on starts sshd on the sbRIO-9627. Starting sshd enables logins over SSH, an encrypted communication protocol. <p> <b>Note</b> Visit <a href="http://ni.com/info">ni.com/info</a> and enter the Info Code <code>openssh</code> for more information about SSH.</p>
LabVIEW Project Access	Rebooting the sbRIO-9627 with this setting on enables you to add the target to a LabVIEW project.

## Configuring FPGA Startup App

Use the RIO Device Setup utility, which you can launch in the following ways, to select an FPGA startup application:

- (Windows 8) Click the **NI Launcher** tile on the Start screen and select **RIO Device Setup**.
- (Windows 7 or earlier) Select **Start»All Programs»National Instruments»RIO Device Setup**.

## Connecting CAN Networks

---

The sbRIO-9627 is populated with one IDC header to provide connections to a CAN bus. This connector has pins for CAN\_H and CAN\_L, which can connect to the CAN bus signals. The CAN port uses an NXP PCA82C251T high-speed CAN transceiver that is fully compatible with the ISO 11898 standard and supports baud rates up to 1 Mbps.

The port has two common pins (GND) that serve as the reference ground for CAN\_H and CAN\_L. You can connect the CAN bus reference ground (sometimes referred to as CAN\_V-) to one or both COM pins. The port also has an optional shield pin (SHLD) that can connect to a shielded CAN cable. Connecting SHLD may improve signal integrity and EMC performance.

## CAN Bus Topology and Termination

A CAN bus consists of two or more CAN nodes cabled together. The CAN\_H and CAN\_L pins of each node are connected to the main CAN bus cable through a short connection called a stub. The pair of signal wires, CAN\_H and CAN\_L, constitutes a transmission line. If the transmission line is not terminated, signal changes on the bus cause reflections that can cause communication errors. The CAN bus is bidirectional, and both ends of the cable must be terminated. However, only the two nodes at the far end of the cable, not every node on the bus, require termination resistors.

The following figure shows a simplified diagram of a CAN bus with multiple CAN nodes and proper termination resistor (Rt) locations.

**Figure 34. CAN Bus Topology and Termination Resistor Locations**

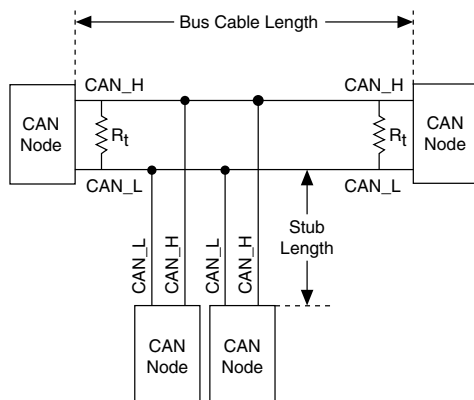

## Cable Specifications

Cables must meet the physical medium requirements specified in ISO 11898, shown in the following table. Belden cable (3084A) meets all these requirements and is suitable for most applications.

**Table 28. ISO 11898 Specifications for Characteristics of a CAN\_H and CAN\_L Pair of Wires**

Characteristic	Value
Impedance	95 $\Omega$ minimum, 120 $\Omega$ nominal, 140 $\Omega$ maximum
Length-related resistance	70 m $\Omega$ /m nominal
Specific line delay	5 ns/m nominal

## Termination Resistors

The termination resistors ( $R_t$ ) must match the nominal impedance of the CAN cable and therefore comply with the values in the following table.

**Table 29. Termination Resistor Specification**

Characteristic	Value	Condition
Termination resistor, $R_t$	100 $\Omega$ min, 120 $\Omega$ nominal, 130 $\Omega$ max	Minimum power dissipation: 220 mW

## Cable Lengths

The cabling characteristics and desired bit transmission rates affect the allowable cable length. You can find detailed cable length recommendations in the ISO 11898, CiA DS 102, and DeviceNet specifications.

ISO 11898 specifies 40 m total cable length with a maximum stub length of 0.3 m for a bit rate of 1 Mb/s. The ISO 11898 specification allows for significantly longer cable lengths at lower bit rates, but NI recommends that you analyze each node for signal integrity problems.

## Number of CAN Nodes

The maximum number of nodes depends on the electrical characteristics of the nodes on the network. If all nodes meet the ISO 11898 requirements, you can connect at least 30 nodes to the bus. You can connect higher numbers of nodes if the electrical characteristics of the node do not degrade signal quality below ISO 11898 signal level specifications.

## File System

---

LabVIEW mounts USB devices and SD cards to the `/media/sdx1` directory and creates symbolic links `/u`, `/v`, `/w`, or `/x` to the media mount point, starting with `/u` if it is available. To prevent any file corruption to external storage devices, verify that any file I/O operations with the specific drive finish before removing the device. Refer to the *LabVIEW Help* for more information.

The file system of the sbRIO-9627 follows conventions established for UNIX-style operating systems. Other LabVIEW Real-Time targets follow Microsoft Windows-style conventions. In order to facilitate the porting of applications from those targets, this target supports the Windows-style `/C` home directory. This path is bound to the UNIX-style directory `/home/lvuser`.

Various LabVIEW Real-Time system files which would be accessible from `C:` (or `/C`) on other LabVIEW Real-Time targets are found in different locations on this target.

UNIX-style file systems support the concept of a symbolic link, which allows access to a file using an alternative file path. For example, it is possible to link `/C/ni-rt/system`, where dynamic libraries are deployed on other LabVIEW Real-Time targets, to `/usr/local/lib`, where they are stored on the sbRIO-9627, if the application requires this.

For more information, visit [ni.com/info](http://ni.com/info) and enter the Info Code `RT_Paths`.

## Worldwide Support and Services

---

The NI website is your complete resource for technical support. At [ni.com/support](http://ni.com/support), you have access to everything from troubleshooting and application development self-help resources to email and phone assistance from NI Application Engineers.

Visit [ni.com/services](https://ni.com/services) for NI Factory Installation Services, repairs, extended warranty, and other services.

Visit [ni.com/register](https://ni.com/register) to register your NI product. Product registration facilitates technical support and ensures that you receive important information updates from NI.

A Declaration of Conformity (DoC) is our claim of compliance with the Council of the European Communities using the manufacturer's declaration of conformity. This system affords the user protection for electromagnetic compatibility (EMC) and product safety. You can obtain the DoC for your product by visiting [ni.com/certification](https://ni.com/certification). If your product supports calibration, you can obtain the calibration certificate for your product at [ni.com/calibration](https://ni.com/calibration).

NI corporate headquarters is located at 11500 North Mopac Expressway, Austin, Texas, 78759-3504. NI also has offices located around the world. For telephone support in the United States, create your service request at [ni.com/support](https://ni.com/support) or dial 1 866 ASK MYNI (275 6964). For telephone support outside the United States, visit the *Worldwide Offices* section of [ni.com/global](https://ni.com/global) to access the branch office websites, which provide up-to-date contact information, support phone numbers, email addresses, and current events.

Information is subject to change without notice. Refer to the *NI Trademarks and Logo Guidelines* at [ni.com/trademarks](https://ni.com/trademarks) for information on NI trademarks. Other product and company names mentioned herein are trademarks or trade names of their respective companies. For patents covering NI products/technology, refer to the appropriate location: **Help»Patents** in your software, the `patents.txt` file on your media, or the *National Instruments Patent Notice* at [ni.com/patents](https://ni.com/patents). You can find information about end-user license agreements (EULAs) and third-party legal notices in the `readme` file for your NI product. Refer to the *Export Compliance Information* at [ni.com/legal/export-compliance](https://ni.com/legal/export-compliance) for the NI global trade compliance policy and how to obtain relevant HTS codes, ECCNs, and other import/export data. NI MAKES NO EXPRESS OR IMPLIED WARRANTIES AS TO THE ACCURACY OF THE INFORMATION CONTAINED HEREIN AND SHALL NOT BE LIABLE FOR ANY ERRORS. U.S. Government Customers: The data contained in this manual was developed at private expense and is subject to the applicable limited rights and restricted data rights as set forth in FAR 52.227-14, DFAR 252.227-7014, and DFAR 252.227-7015.

© 2015—2017 National Instruments. All rights reserved.

375466B-01 April 13, 2017