CPS-8910

Getting Started

2024-12-16



Contents

Overview	3
CPS-8910 Description	3
What You Need to Get Started	4
Unpacking the Kit	4
Electromagnetic Compatibility Guidelines	5
Installing the CPS-8910 in a Rack	5
Providing Adequate Clearance	6
Specifications	7
NI Services	7

Overview

This document explains how to install the CPS-8910.

© 2016 National Instruments Corporation. All rights reserved. Refer to the <National Instruments>_Legal Information directory for information about NI copyright, patents, trademarks, warranties, product warnings, and export compliance.

CPS-8910 Description

The CPS-8910 is a 1U rack-mountable PCI Express 10-port switch. It has a Gen 2 PCI Express x8 upstream port, a Gen 1 PCI Express x4 upstream port, and eight Gen 1 PCI Express x4 downstream ports to enable linking any PCI Express host to multiple expansion chassis or peripheral devices.

The following figure shows the key features of the CPS-8910 front and rear panels.

Figure 1. CPS-8910 Front and Rear Panels

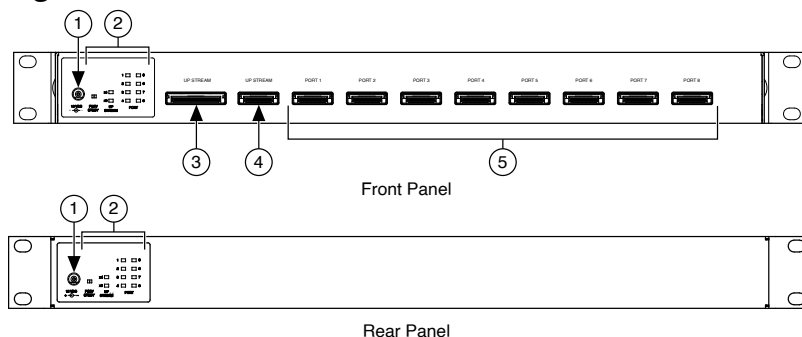

1. 12 V Power Supply Input
2. LED Indicators
3. x8 Gen 2 Upstream Port
4. x4 Gen 1 Upstream Port
5. x4 Gen 1 Downstream Ports

Both the front and rear panels include the following LEDs:

- Power indicator—illuminates when the CPS-8910 is powered on.

- Up Stream
 - Off—no connection.
 - On—connected to a x8 upstream device.
 - Blinking—connected to a x4 upstream device.
- Ports (1 through 8)
 - Off—no connection.
 - Blinking at 75% duty cycle—connected.

What You Need to Get Started

The following items are included in the device kit:

- Cabled PCI Express Switch Box x4 10 port
- Rack-mounting brackets
- ***CPS-8910 Getting Started Guide***
- 12 V, 24 W power supply



Note If you are using the CPS-8910 with fiber optic cables, you must purchase a 12 V, 50 W power supply with the proper connection from a different source. Refer to the [Specifications](#) section of this document for power supply connector information.

The following items are available on ni.com:

- Copper or fiber optic PCI Express cable



Note The maximum copper cable length for the x8 upstream port is 2 m. All other copper cables have a maximum length of 7 m. Refer to the [Electromagnetic Compatibility Guidelines](#) section for more information.

Unpacking the Kit



Notice To prevent electrostatic discharge (ESD) from damaging the device, ground yourself using a grounding strap or by holding a grounded object,

such as your computer chassis.

1. Touch the antistatic package to a metal part of the computer chassis.
2. Remove the device from the package and inspect the device for loose components or any other sign of damage.



Notice Never touch the exposed pins of connectors.



Note Do not install a device if it appears damaged in any way.

3. Unpack any other items and documentation from the kit.

Store the device in the antistatic package when the device is not in use.

Electromagnetic Compatibility Guidelines

This product was tested and complies with the regulatory requirements and limits for electromagnetic compatibility (EMC) stated in the product specifications. These requirements and limits provide reasonable protection against harmful interference when the product is operated in the intended operational electromagnetic environment.

This product is intended for use in industrial locations. However, harmful interference may occur in some installations, when the product is connected to a peripheral device or test object, or if the product is used in residential or commercial areas. To minimize interference with radio and television reception and prevent unacceptable performance degradation, install and use this product in strict accordance with the instructions in the product documentation.

Furthermore, any changes or modifications to the product not expressly approved by National Instruments could void your authority to operate it under your local regulatory rules.

Installing the CPS-8910 in a Rack

The CPS-8910 comes with adjustable rack-mount ears for front or rear-facing installation, as shown in the following figure. Complete the following steps to install the CPS-8910 and connect devices to it.



Caution When mounting the equipment in the rack, do not create a hazardous condition due to uneven mechanical loading.

1. Mount the CPS-8910 in the desired position by installing the rack-mount ears and tightening the four rack-mounting screws as shown.

Figure 2. CPS-8910 Rack-Mount Ear Installation

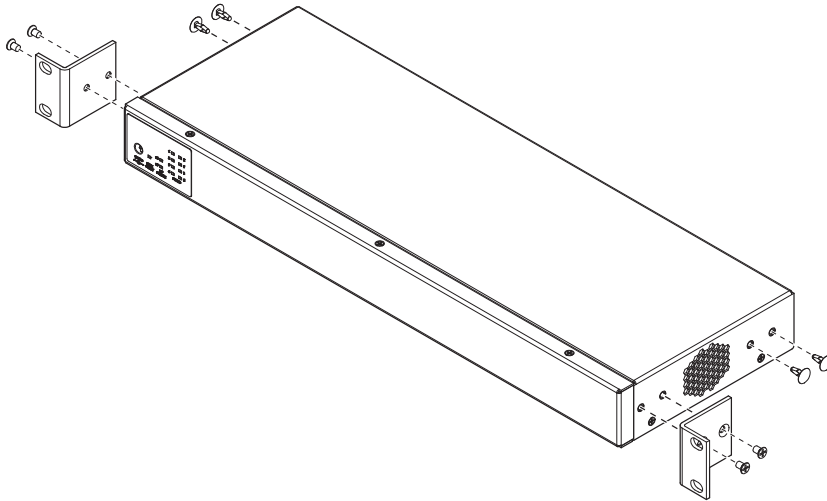

2. Connect the 12 V power supply to the CPS-8910.
3. Connect the PCI Express host device to either the x8 or x4 upstream port connection.
4. Connect up to eight PCI Express expansion systems or devices to the x4 downstream ports.
5. Power on the chassis or computer containing the PXI Express or PCI Express host.

Providing Adequate Clearance

Apertures along both sides of the CPS-8910 facilitate cooling.

Place the CPS-8910 in an instrument rack so that the apertures have adequate ventilation. Keep other equipment a minimum of 76.2 mm (3 in.) away from the air outlets on the sides of the CPS-8910.

Specifications

The following document(s) provide(s) the specifications for the switch device for PCI Express.

[CPS-8910 Specifications](#)

NI Services

Visit ni.com/support to find support resources including documentation, downloads, and troubleshooting and application development self-help such as tutorials and examples.

Visit ni.com/services to learn about NI service offerings such as calibration options, repair, and replacement.

Visit ni.com/register to register your NI product. Product registration facilitates technical support and ensures that you receive important information updates from NI.

NI corporate headquarters is located at 11500 N Mopac Expwy, Austin, TX, 78759-3504, USA.