PXle-1088 User Guide

2024-08-21



Contents

PXIe-1088	4
Related Documentation	4
Getting Started	4
Unpacking	4
What You Need to Get Started	5
Key Features	5
High Performance for Instrumentation Requirements	5
High Reliability	6
Optional Features	6
Chassis Components	6
Optional Equipment	8
EMC Filler Panels	8
Slot Blockers	8
Handle and Feet Kit	8
Rack Mount Kits	8
Replaceable Fan Kit	8
PXIe-1088 Backplane Overview	8
Interoperability with CompactPCI	8
System Controller Slot	9
Hybrid Peripheral Slots	9
PXI Local Bus	10
PXI Trigger Bus	11
System Reference Clock	11
Installation and Configuration	12
Safety Information	12
Chassis Cooling Considerations	13
Providing Adequate Clearance	14
Chassis Ambient Temperature Definition	16
Setting Fan Speed	16
Installing Filler Panels	16
Installing Slot Blockers	16
Rack Mounting	16

Connecting the Safety Ground	17
Connecting to a Power Source	18
Installing a System Controller	18
Installing Peripheral Modules	19
LED Indicator	20
DIP Switches	21
Inhibit Mode	22
Inhibit Mode Selection	22
Fan Mode	23
Cooling Profiles	23
Fan Mode Selection	23
PXI Express System Configuration with MAX	24
Trigger Configuration in MAX	24
PXI Trigger Bus Routing	26
Fan Configuration in MAX	27
Using System Configuration and Initialization Files	28
Maintenance	28
Service Interval	28
Preparation	29
Cleaning	29
Interior Cleaning	29
Exterior Cleaning	29
NI Services	30

PXIe-1088

This document describes the features of the PXIe-1088 chassis and contains information about configuring the chassis, installing the modules, and operating the chassis.

© 2019 National Instruments Corporation. All rights reserved. Refer to the `<National Instruments>_Legal Information` directory for information about NI copyright, patents, trademarks, warranties, product warnings, and export compliance.

Related Documentation

The following documents contain information that you might find helpful as you read this manual:

- IEEE 1101.1-1991, ***IEEE Standard for Mechanical Core Specifications for Microcomputers Using IEC 603-2 Connectors***
- IEEE 1101.10, ***IEEE Standard for Additional Mechanical Specifications for Microcomputers Using IEEE 1101.1 Equipment Practice***
- ***PICMG EXP.0 R1.0 CompactPCI Express Specification***, PCI Industrial Computers Manufacturers Group
- ***PCI Express Base Specification***, Revision 2.0, PCI Special Interest Group
- ***PXI-5 PXI Express Hardware Specification***, Revision 2.0, PXI Systems Alliance

Unpacking

Carefully inspect the shipping container and the chassis for damage. Check for visible damage to the metal work. Check to make sure all handles, hardware, and switches are undamaged. Inspect the inner chassis for any possible damage, debris, or detached components. If the chassis was damaged during shipment, file a claim with the carrier. Retain the packing material for possible inspection and/or reshipment.

What You Need to Get Started

The PXIe-1088 chassis kit contains the following items:

- PXIe-1088 chassis
- Filler panel
- Software media with **PXI Platform Services 20.5** or newer
- Chassis number labels



Note You also will need an AC power cable, sold separately. Refer to the following table for more information about AC power cables.

Table 1. AC Power Cables

Power Cable	Reference Standards
Standard 120 V (USA)	ANSI C73.11/NEMA 5-15-P
Switzerland 220 V	SEV 6534-2
Australia 240 V	AS C112
Universal Euro 230 V	CEE (7), II, IV, VII
United Kingdom 230 V	BS 1363
Japan 100 V	JIS 8303

If you are missing any of the items or have the incorrect AC power cable, contact NI.

Key Features

The PXIe-1088 chassis combines a high-performance 9-slot PXI Express backplane with a power supply and a structural design that has been optimized for maximum usability in a wide range of applications. The PXIe-1088 chassis fully complies with the **PXI-5 PXI Express Hardware Specification**.

The key features of the PXIe-1088 chassis include the following:

High Performance for Instrumentation Requirements

- Up to 500 MB/s or 2 GB/s (single direction) per PXI Express slot dedicated bandwidth (x1 or x4 Gen-2 PCI Express).
 - 3 hybrid peripheral slots connect as x4 links to the system slot.
 - 5 hybrid peripheral slots connect as x1 links to a PCI Express switch, which connects to the system slot through a x4 link.
- 58 W per slot cooling meets increased PXI Express cooling requirements. Refer to the **PXIe-1088 Specifications** for more details.
- Low-jitter internal 10 MHz reference clock for PXI/PXI Express slots with ± 25 ppm stability
- Low-jitter internal 100 MHz reference clock for PXI Express slots with ± 25 ppm stability
- Quiet operation for 0 °C to 30 °C at 44.3 dBA
- Variable speed fan controller optimizes cooling and acoustic emissions
- Complies with PXI and CompactPCI specifications

High Reliability

- 0 °C to 50 °C temperature range
- Power supply, temperature, and fan monitoring
- Field replaceable fans

Optional Features

- Front and rear rack-mount kits
- EMC filler panels
- Slot blockers for improved cooling performance
- Factory installation services
- Handle and rubber feet kit

Chassis Components

The following figures show key features of the PXIe-1088 chassis front and back panels.

Figure 1. Front View of the PXIe-1088

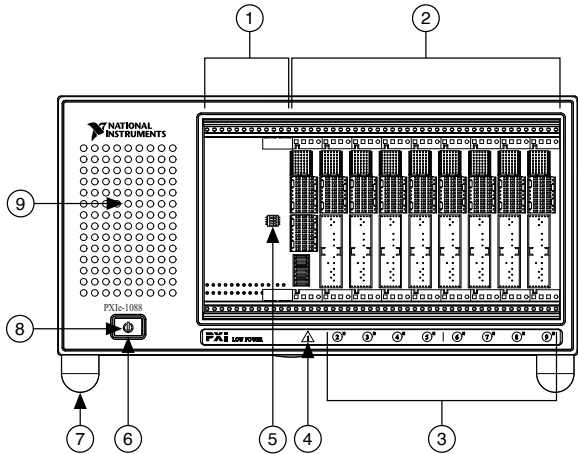

1. System Controller Expansion Slot
2. Backplane Connectors
3. PXI Express Hybrid Peripheral Slots (8x)
4. PXI Express System Controller Slot
5. Dip Switch
6. Power Inhibit Switch
7. Removable Feet
8. Status LED
9. Power Supply Airflow Intake Vents

Figure 2. Rear View of the PXIe-1088

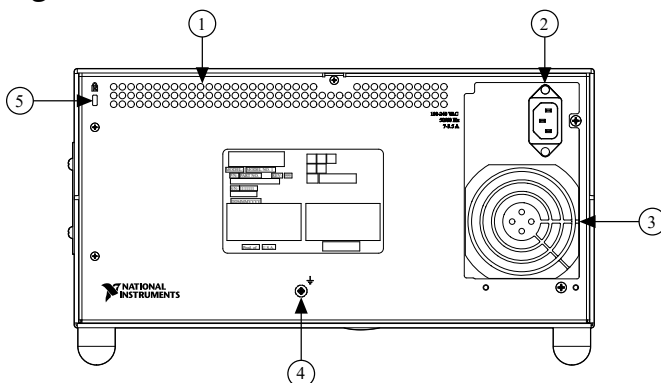

1. Rear Exhaust Vent
2. Universal AC Input
3. Power Supply Fan Exhaust
4. Chassis Protective Earth Terminal
5. Kensington Slot

Optional Equipment

Contact NI to order the following options for the PXIe-1088 chassis.

EMC Filler Panels

EMC filler panel kits are available from NI.

Slot Blockers

PXI Slot Blocker kits are available from NI for improved thermal performance when all slots are not used.

Handle and Feet Kit

An optional side handle and rubber feet kit is available from NI to provide portability.

Rack Mount Kits

Rack mounting kits are available from NI that can accommodate a variety of rack depths.

Replaceable Fan Kit

A fan kit is available from NI.

Interoperability with CompactPCI

The design of the PXIe-1088 provides you the flexibility to use the following devices in a single PXI Express chassis:

- PXI Express compatible products
- CompactPCI Express compatible 2-Link system controller products
- CompactPCI Express compatible Type-2 peripheral products
- PXI peripheral products modified to fit in a hybrid slot
- Standard CompactPCI peripheral products modified to fit in a hybrid slot

System Controller Slot

The system controller slot is slot 1 of the chassis and is a 4-Link configuration system slot as defined by the CompactPCI Express and PXI Express specifications. The chassis includes three system controller expansion slots for system controller modules that are wider than one slot. These slots allow the system controller to expand to the left to prevent the system controller from using peripheral slots.

The backplane routes three PCI Express links from the system slot to peripheral slots as x4 links (slots 4, 6, and 8). The other system slot link is routed as a x4 link to the PCI Express switch providing x1 PCI Express links to the remaining peripheral slots and the two PCI Express-to-PCI bridges providing a PCI bus to the hybrid peripheral slots.

The system controller slot also has connectivity to some PXI features such as: PXI_CLK10, PXI Trigger Bus, and PXI Local Bus.

By default, the system controller will control the power supply with the PS_ON# signals. A logic low on this line will turn the power supply on.



Note The chassis Inhibit Mode must be set to Default mode for the system controller to control the power supply.

Hybrid Peripheral Slots

The chassis provides eight (8) hybrid peripheral slots as defined by the **PXI-5 PXI Express Hardware Specification**: slots 2 through 9. A hybrid peripheral slot can accept the following peripheral modules:

- A PXI Express peripheral with x8, x4, or x1 PCI Express link through a switch to the system slot. Each PXI Express peripheral slot can link up to a Gen-2 x4 PCI Express, providing a maximum nominal single-direction bandwidth of 2 GB/s (slots 4, 6, and 8) or up to a Gen-2 x1 PCI Express, providing a maximum nominal single-direction bandwidth of 500 MB/s (slots 2, 3, 5, 7, and 9).
- A CompactPCI Express Type-2 Peripheral with x8, x4, or x1 PCI Express link to the system slot or through a PCI Express switch or direct link to the system slot.

- A hybrid-compatible PXI Peripheral module modified by replacing the J2 connector with an XJ4 connector installed in the upper eight rows of J2. Refer to the **PXI Express Specification** for details. The PXI peripheral communicates through the backplane's 32-bit PCI bus.
- A CompactPCI 32-bit peripheral on the backplane's 32-bit PCI bus.

The hybrid peripheral slots provide full PXI Express functionality and 32-bit PXI functionality except for PXI Local Bus. The hybrid peripheral slot connects to only PXI Local Bus 6 left and right.

Figure 3. PXIe-1088 PCI Express Backplane Diagram

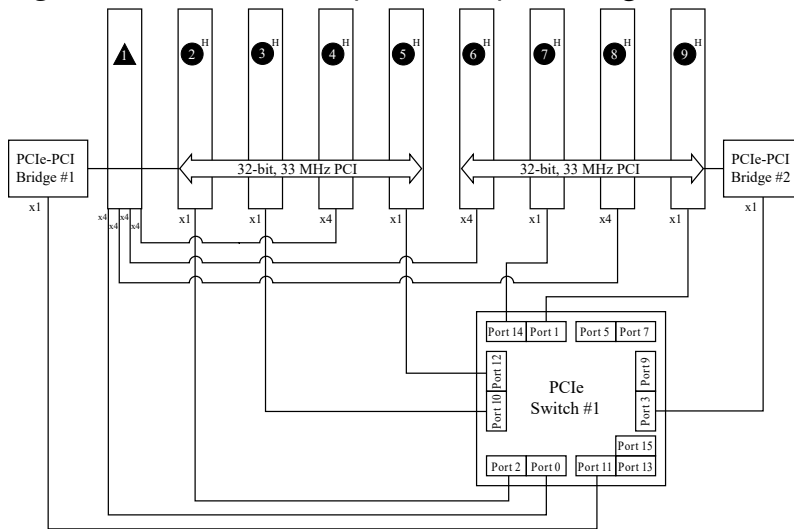

PXI Local Bus

The PXI backplane local bus is a daisy-chained bus that connects each peripheral slot with adjacent peripheral slots to the left and right.

The backplane routes PXI Local Bus 6 between adjacent PXI slots. The left local bus 6 from slot 1 is not routed anywhere, and the right local bus 6 from slot 9 is not routed anywhere.

The backplane routes PXI Local Bus between all slots. Local bus signals may range from high-speed TTL signals to analog signals as high as 42 V.

Initialization software uses the configuration information specific to each adjacent peripheral module to evaluate local bus compatibility.

PXI Trigger Bus

All slots on the same PXI bus segment share eight PXI trigger lines. You can use these trigger lines in a variety of ways. For example, you can use triggers to synchronize the operation of several different PXI peripheral modules. Modules can pass triggers to one another on the lines, allowing precisely timed responses to asynchronous external events the system is monitoring or controlling.

The PXI trigger lines from adjacent PXI trigger bus segments can be routed in either direction across the PXI trigger bridges through buffers. This allows you to send trigger signals to, and receive trigger signals from, every slot in the chassis. Static trigger routing (user-specified line and directional assignments) can be configured through Measurement & Automation Explorer (MAX). Dynamic routing of triggers (automatic line assignments) is supported through certain National Instruments drivers like NI-DAQmx.



Note Although any trigger line may be routed in either direction, it cannot be routed in more than one direction at a time.

Figure 4. PXI Trigger Bus Connectivity Diagram

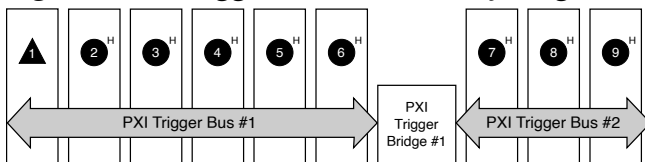

System Reference Clock

The PXIe-1088 chassis supplies PXI_CLK10, PXIe_CLK100 and PXIe_SYNC100 to every peripheral slot with an independent driver for each signal.

An independent buffer (having a source impedance matched to the backplane and a skew of less than 250 ps between slots) drives PXI_CLK10 to each peripheral slot. You can use this common reference clock signal to synchronize multiple modules in a measurement or control system.

An independent buffer drives PXIe_CLK100 to each peripheral slot. These clocks are matched in skew to less than 100 ps. The differential pair must be terminated on the

peripheral with LVPECL termination for the buffer to drive PXIe_CLK100 so that when there is no peripheral or a peripheral that does not connect to PXIe_CLK100, there is no clock being driven on the pair to that slot.

An independent buffer drives PXIe_SYNC100 to each peripheral slot. The differential pair must be terminated on the peripheral with LVPECL termination for the buffer to drive PXIe_SYNC100 so that when there is no peripheral or a peripheral that does not connect to PXIe_SYNC100, there is no SYNC100 signal being driven on the pair to that slot.

PXI_CLK10, PXIe_CLK100 and PXIe_SYNC100 have the default timing relationship described in the following figure.

Figure 5. System Reference Clock Default Behavior

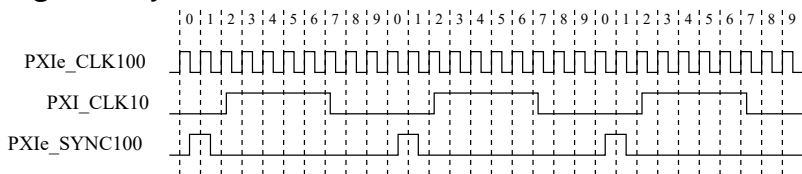

Installation and Configuration

The following section describes how to prepare and operate the PXIe-1088 chassis.

Before connecting the chassis to a power source, read this section and the ***Read Me First: Safety and Electromagnetic Compatibility*** document included with your kit.

Safety Information



Caution Before undertaking any troubleshooting, maintenance, or exploratory procedure, carefully read the following caution notices.



Caution Protection may be impaired if equipment is not used in the manner specified.

This equipment contains voltage hazardous to human life and safety, and is capable of inflicting personal injury.

- Protective Earth—The facility installation must provide a means for connection to protective earth.
- Protective Earth Terminal Wiring—Qualified personnel must install a protective earthing conductor from the chassis protective earth terminal (using an #8-32 SEMS screw) on the rear to the protective earth wire in the facility.

Grounding wire	2.1 mm ² (14 AWG)
Ring lug	#8
Protective earth terminal torque	1.13 N · m (10 lb · in.)

- Chassis Grounding—The chassis requires a connection from the premise wire safety ground to the chassis ground. The earth safety ground must be connected during use of this equipment to minimize shock hazards. Refer to the **Connecting Safety Ground** section for instructions on connecting safety ground.
- Live Circuits—Operating personnel and service personnel must not remove protective covers when operating or servicing the chassis. Adjustments and service to internal components must be undertaken by qualified service technicians. During service of this product, the mains connector to the premise wiring must be disconnected. Dangerous voltages may be present under certain conditions; use extreme caution.
- Explosive Atmosphere—Do **not** operate the chassis in conditions where flammable gases are present. Under such conditions, this equipment is unsafe and may ignite the gases or gas fumes.
- Part Replacement—Only service this equipment with parts that are exact replacements, both electrically and mechanically. Contact NI for replacement part information. Installation of parts with those that are not direct replacements may cause harm to personnel operating the chassis. Furthermore, damage or fire may occur if replacement parts are unsuitable.
- Modification—Do not modify any part of the chassis from its original condition. Unsuitable modifications may result in safety hazards.

Chassis Cooling Considerations

The PXIe-1088 chassis is designed to operate on a bench or in an instrument rack. You must adhere to the cooling clearances as outlined in the following section.

Providing Adequate Clearance

The module and power supply intake vents are located on the front, left side, and bottom of the chassis. The module and power supply exhaust vents for the PXIe-1088 are located on the top, side, and rear of the chassis.

Adequate clearance between the chassis and surrounding equipment, heat generating devices, and air flow blockages must be maintained to ensure proper cooling. Minimum cooling clearances are shown in the following figure. For rack mount applications adequate forced air ventilation is required. For benchtop applications additional cooling clearances may be required for optimal air flow and reduced hot air recirculation to the air inlet fans.

Figure 6. PXIe-1088 Cooling Clearances

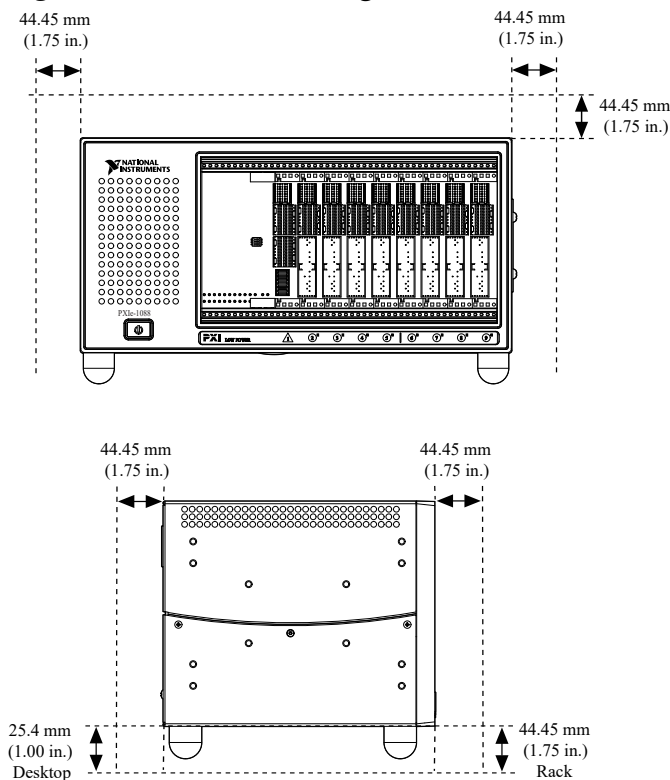

Caution Failure to provide these clearances may result in undesired thermal-related issues with the chassis or modules.

To aid in thermal health monitoring for either rack or benchtop use you can monitor the chassis intake temperatures in Measurement & Automation Explorer (MAX) to ensure the temperatures do not exceed the ratings in the **Operating Environment** section of the **PXIe-1088 Specifications**.

Additionally, many PXI modules provide temperature values you can monitor to ensure critical temperatures are not exceeded. Increasing chassis clearances, ventilation, reducing external ambient temperatures, and removing nearby heat sources are all options for improving overall chassis thermal performance.

Figure 7. PXIe-1088 Vents

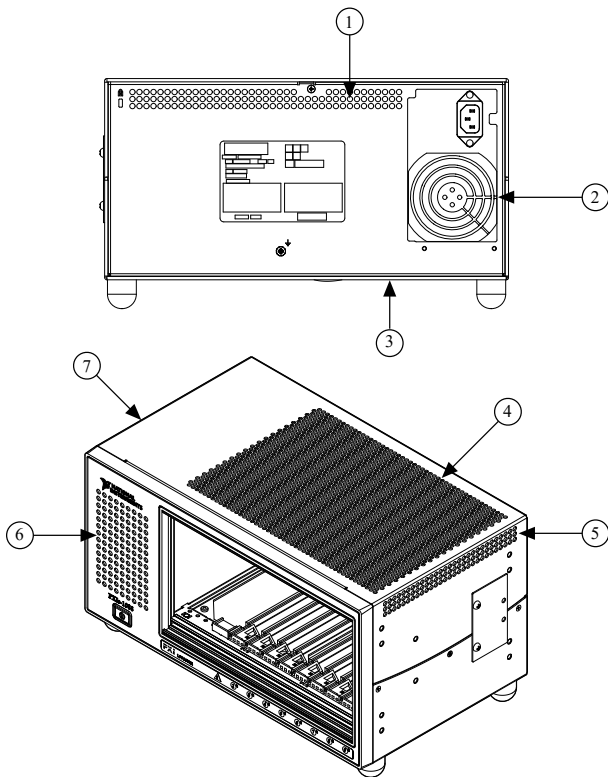

1. Air Exhaust Vent
2. Air Exhaust Vent
3. Air Intake
4. Air Exhaust Vent
5. Air Exhaust Vent
6. Air Intake
7. Air Intake



Note The side exhaust vent (not shown) is located on the left side of the chassis.

Chassis Ambient Temperature Definition

The chassis fan control system uses ambient intake air temperatures for controlling fan speeds when in Auto mode. These temperatures may be higher than ambient room temperature depending on surrounding equipment and/or airflow blockages. Ensure ambient intake temperatures do not exceed the ratings in the **Operating Environment** section of the **PXIe-1088 Specifications**. You can monitor the module ambient intake temperatures in NI Measurement & Automation Explorer (MAX).

Setting Fan Speed

The PXIe-1088 chassis supports multiple fan operating modes. Refer to the **Fan Mode** section for more information.

Installing Filler Panels

To maintain proper module cooling performance, install filler panels (one is provided with the chassis) in unused or empty slots. Secure with the captive mounting screws provided.

Installing Slot Blockers

You can improve the cooling performance of the chassis by installing optional slot blockers. Refer to the NI website at ni.com/info and enter the Info Code `slotblocker` for more information about slot blockers.

Rack Mounting

Rack mount applications require optional rack mount kits available from National Instruments. Refer to the instructions supplied with the rack mount kits to install your

PXIe-1088 chassis in an instrument rack.



Note You may want to remove the feet from the PXIe-1088 chassis when rack mounting.

Figure 8. PXIe-1088 Rack Mount Kit Components

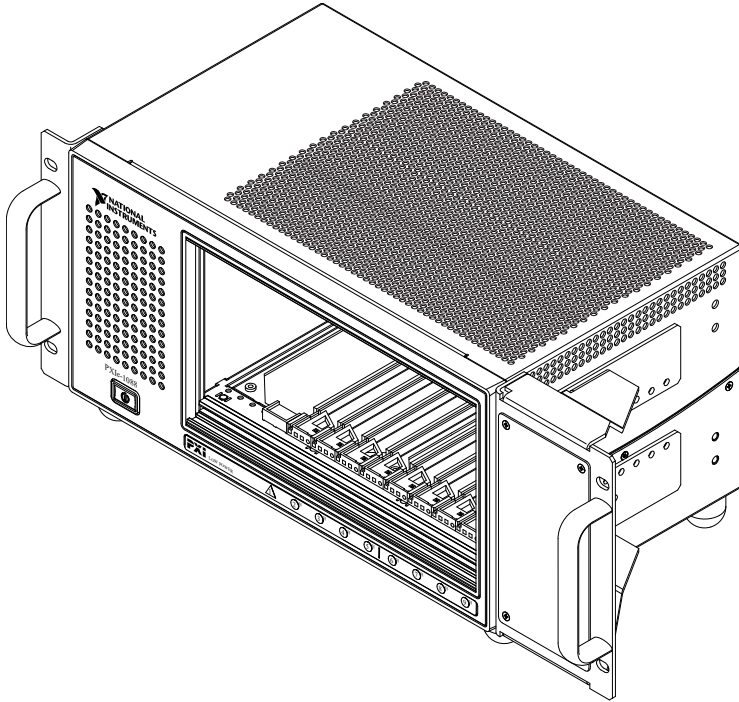

Connecting the Safety Ground



Caution The PXIe-1088 chassis are designed with a three-position IEC 60320 C14 inlet for the U.S. that connects the ground line to the chassis ground. For proper grounding, a suitable cordset must be used to connect this inlet to an appropriate earth safety ground.

If your power outlet does not have an appropriate ground connection, you must connect the premise safety ground to the chassis grounding screw located on the rear panel. To connect the safety ground, complete the following steps:

1. Connect a 16 AWG (1.3 mm) wire to the chassis grounding screw (#8-32 SEMS) using a grounding lug. The wire must have green insulation with a yellow stripe or must be noninsulated (bare).

2. Attach the opposite end of the wire to permanent earth ground using toothed washers or a toothed lug.

Connecting to a Power Source



Caution Do not install modules prior to performing the following power-on test. To completely remove power, you must disconnect the AC power cable.

Attach input power through the rear AC inlet using the appropriate AC power cable supplied.

The Power Inhibit switch allows you to power on the chassis or place it in standby mode. With an empty chassis in Default Mode, press down the Power Inhibit switch and hold it down for four seconds. Observe that all fans become operational and the front panel LED is a steady green. Pressing and holding the Power Inhibit switch again for four seconds will return the chassis to standby.

Installing a System Controller

This section contains general installation instructions for installing a PXI Express system controller in a PXIe-1088 chassis.

1. Connect the AC power source to the PXI Express chassis before installing the system controller. The AC power cord grounds the chassis and protects it from electrical damage while you install the system controller.
2. Install the system controller into the system controller slot (slot 1, indicated by the red card guides) by first placing the system controller PCB into the front of the card guides (top and bottom). Slide the system controller to the rear of the chassis, making sure that the injector/ejector handle is pushed down as shown in the following figure.

Figure 9. Installing a PXI Express System Controller

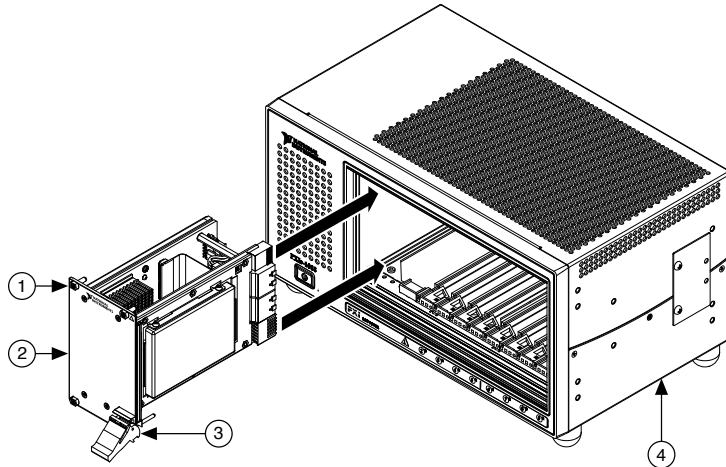

1. System Controller Front Panel Mounting Screws (4x)
 2. PXI Express System Controller
 3. Injector/Ejector Handle
 4. PXI Express Chassis
3. When you begin to feel resistance, pull up on the injector/ejector handle to seat the system controller fully into the chassis frame. Secure the system controller front panel to the chassis using the system controller front panel mounting screws.
 4. Connect the keyboard, mouse, and monitor to the appropriate connectors. Connect devices to ports as required by your system configuration.
 5. Power on the chassis. Verify that the system controller boots. If the system controller does not boot, refer to the **Troubleshooting** section or your system controller user manual.

Installing Peripheral Modules

This section contains general installation instructions for installing a peripheral module in a PXIe-1088 chassis. Refer to your peripheral module user manual for specific instructions and warnings. To install a module, complete the following steps:

1. Connect the AC power source to the PXI Express chassis before installing the module. The AC power cord grounds the chassis and protects it from electrical damage while you install the module.
2. Ensure that the chassis is powered off.
3. Install a module into a chassis slot by first placing the module card PCB into the front of the card guides (top and bottom), as shown in the following figure. Slide the module to the rear of the chassis, making sure that the injector/ejector handle

is pushed down, as shown in the following figure.

- When you begin to feel resistance, push up on the injector/ejector handle to fully seat the module into the chassis frame. Secure the module front panel to the chassis using the module front-panel mounting screws.

Figure 10. Installing PXI, PXI Express, or CompactPCI Peripheral Modules

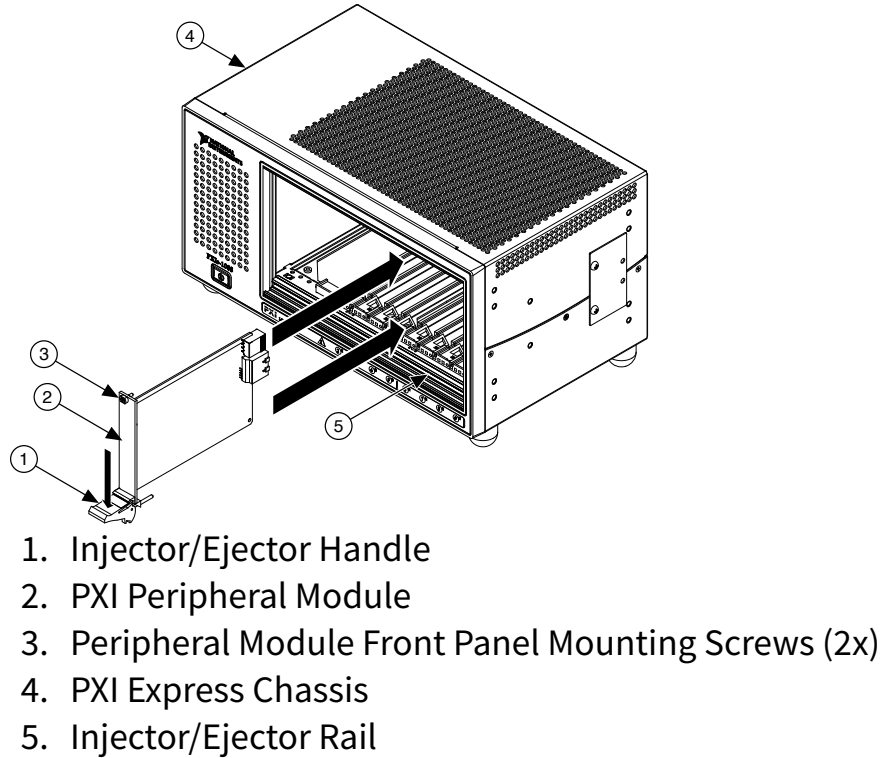

LED Indicator

The following figure shows the front panel Status LED. The following table describes the Status LED states.

Figure 11. Status LED

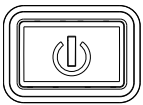

Table 2. Front Panel Status LED States

LED	State	Description
Status LED	Off	Chassis is powered off.
	Steady green	Chassis is powered on, and operating normally.

LED	State	Description
	Steady red	Indicates temperature is out of range, or an internal chassis fault has occurred.

DIP Switches

The backplane has a DIP switch that may be used to control chassis behavior.

DIP switch #1 (first from the bottom) controls the chassis fan mode. When this switch is in the off (right) position, Auto mode is selected. When this switch is in the on (left) position, High mode is selected.

DIP switch #2 (second from the bottom) controls the chassis Inhibit Mode. When this switch is in the off (right) position, Default mode is selected. When this switch is in the on (left) position, Manual mode is selected.

Figure 12. Backplane DIP Switches

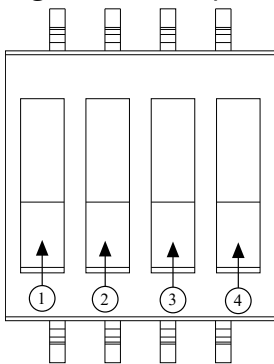

1. Switch #1 (Fan)
2. Switch #2 (PWR)
3. Switch #3 (NC)
4. Switch #4 (NC)

Table 3. DIP Switch States

Location	Switch	State	Description
1	FAN	Off (Right)	Set chassis fan mode to Auto. Refer to the Fan

Location	Switch	State	Description
			Mode section for information.
		On (Left)	Set chassis fan mode to High.
2	PWR	Off (Right)	Set chassis inhibit mode to Default. Refer to the Inhibit Mode section for information
		On (Left)	Set chassis inhibit mode to Manual.
3	NC	-	-
4	NC	-	-

Inhibit Mode

The PXIe-1088 chassis supports operation in two inhibit modes. Default mode is used when normal power inhibit button functionality is desired. In Default mode, when a system controller is installed in slot 1 of the chassis, the user can press the power inhibit button to power on the chassis.



Note In Default mode, you can also power on the chassis without a system controller installed in slot 1. To power on the chassis from standby, press and hold the power inhibit button for 4 seconds. To power off the chassis, again press and hold the power inhibit button for 4 seconds.

When the chassis is in Manual mode, the chassis will power up when AC power is applied and shut down when AC power is removed.

Inhibit Mode Selection

You can select the chassis Inhibit Mode using Measurement & Automation Explorer (MAX). Refer to the **Inhibit Mode Configuration in MAX** section for more information.

You also can select the chassis Inhibit Mode on the PXIe-1088 chassis using a DIP switch on the backplane. Refer to the **DIP Switches** section for more information about DIP switch settings. Refer to Figure 1, **Front View of the PXIe-1088**, for the switch location.



Note The DIP switch must be in the Default position for software configuration in MAX to work. If the DIP switch is in the Manual position, the Inhibit Mode will be Manual regardless of the software setting.

Fan Mode

The PXIe-1088 chassis operates in two main fan modes.

In Auto mode, the chassis intake air temperature determines the chassis fans' speed. Select Auto mode for improved acoustic performance.

In High mode, the chassis fans' speed is fixed at high speed regardless of chassis intake air temperature. Select High mode for maximum cooling performance.

Cooling Profiles

Both fan modes are available within the 38 W and 58 W cooling profiles.

- 38 W cooling profile supports NI modules up to 38 W max power dissipation
- 58 W cooling profile supports NI modules up to 58 W max power dissipation



Note Refer to Operating Environment requirements in the **PXIe-1088 Specifications** for more information about chassis ambient temperature range and cooling capacity.

Fan Mode Selection

The chassis fan mode can be selected using Measurement & Automation Explorer (MAX). Refer to the **Fan Configuration in MAX** section for more information.

Alternatively, the fan mode on the PXIe-1088 chassis is selected using a DIP switch on the backplane. Refer to the **DIP Switches** section for more information about the DIP switch.



Note The DIP switch must be in the Auto position for software configuration in MAX to work. If the DIP switch is in the High position, the chassis fan mode will be High regardless of the software setting.

PXI Express System Configuration with MAX

The PXI Platform Services software included with your chassis automatically identifies your PXI Express system components to generate a `pxiesys.ini` file. You can configure your entire PXI system and identify PXI-1 chassis through Measurement & Automation Explorer (MAX), included with your system controller. PXI Platform Services creates the `pxiesys.ini` and `pxisys.ini` file, which define your PXI system parameters.



Note The configuration steps for single or multiple-chassis systems are the same.

MAX provides the following chassis information:

- Asset information, such as serial number or part number
- Chassis number
- Voltages, temperatures, and fan speed
- Fan and cooling settings
- Slot details
- Chassis self-test
- Firmware update



Note Information available through MAX may vary based on your chassis variant or firmware and platform services version.

Trigger Configuration in MAX

PXI Platform Services provides an interface to route and reserve triggers so dynamic routing, through drivers such as DAQmx, avoids double-driving and potentially damaging trigger lines. For more information about routing and reserving PXI triggers, refer to KnowledgeBase 3TJDOND8 at ni.com/support.

Each chassis has one or more trigger buses, each with eight lines numbered 0 through 7 that can be reserved and routed statically or dynamically. Static reservation **pre-allocates** a trigger line to prevent its configuration by a user program. Dynamic reservation/routing/deallocation is **on the fly** within a user program based on NI APIs such as NI-DAQmx. NI recommends dynamic reservations and routing are used whenever possible. If static reservations are required, static reservation of trigger lines can be implemented by the user in MAX through the Triggers tab. PXI modules dynamically configured by programs such as NI-DAQmx will not use reserved trigger lines. This prevents the instruments from double-driving the trigger lines, possibly damaging devices in the chassis. In the default configuration, trigger lines on each bus are independent. For example, if trigger line 3 is asserted on trigger bus 0, by default it is not asserted automatically on any other trigger bus.

Complete the following steps to reserve these trigger lines in MAX.

1. In the Configuration tree, click the PXI chassis branch to configure.
2. In the lower right pane, click the Triggers tab.
3. Select the trigger lines to statically reserve.
4. Click the Save button.

Figure 1. Trigger Configuration in MAX

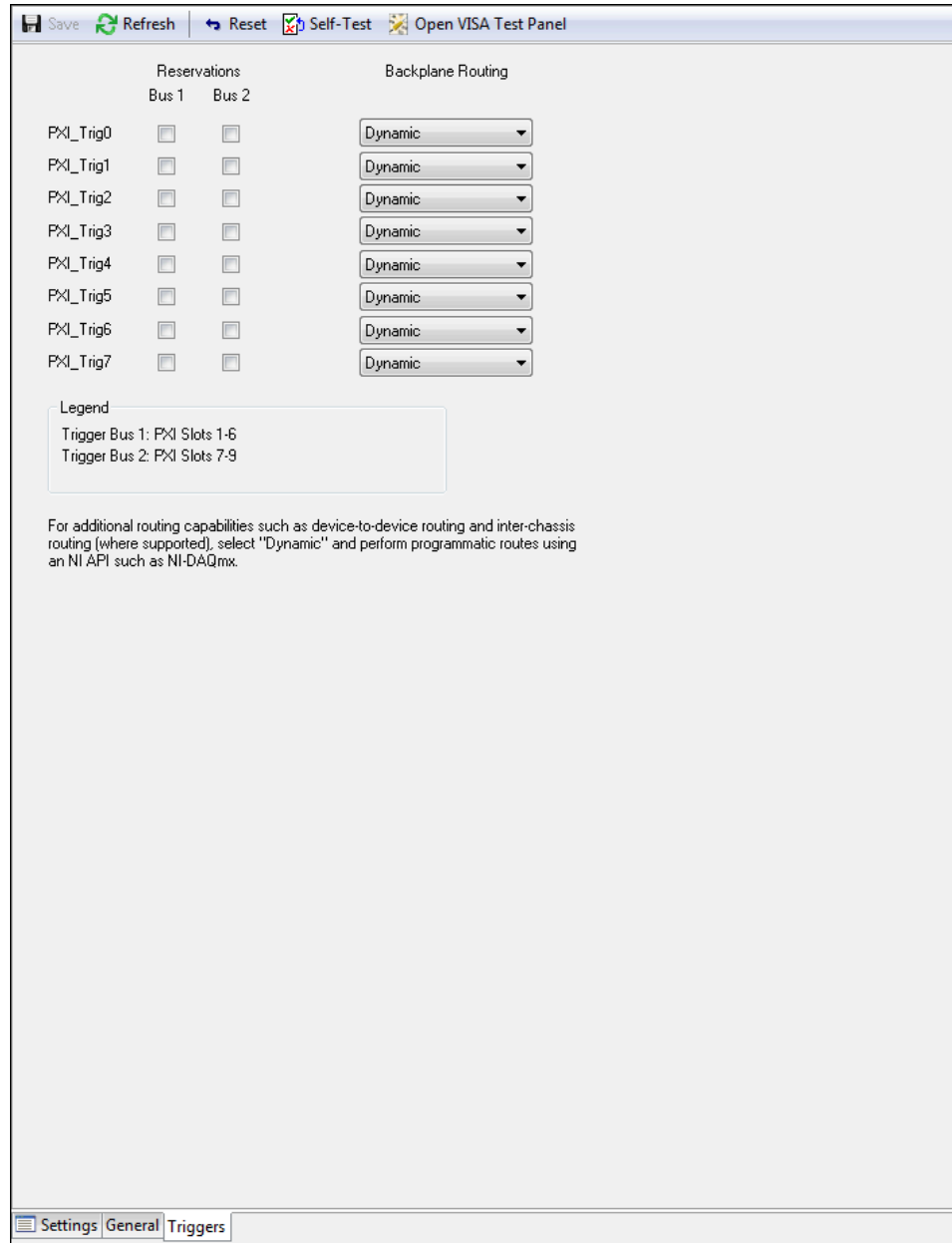

PXI Trigger Bus Routing

Some NI chassis, such as the PXIe-1088, have the capability to route triggers from one bus to others within the same chassis using the **Trigger Routing** tab in MAX.



Note Selecting any non-disabled routing automatically reserves the line in all trigger buses being routed to. If you are using NI-DAQmx, it will reserve and route trigger lines for you, so you won't have to route trigger lines

manually.

Complete the following steps to configure trigger routings in MAX.

1. In the **Configuration** tree, select the chassis in which you want to route trigger lines.
2. In the right-hand pane, select the **Trigger Routing** tab near the bottom.
3. For each trigger line, select **Away from Bus 1** or **Away from Bus 2** to route triggers on that line in the described direction, or select **Dynamic** for the default behavior with no manual routing.
4. Click the **Save** button.

Fan Configuration in MAX

You can configure fan behavior using software settings in MAX.

The PXIe-1088 supports both Auto and High fan modes for both the 38 W and 58 W cooling profiles. Refer to the **Fan Mode** section for more information about these modes.

You may also select a Manual fan mode. In this mode, you may manually set the fan speeds to achieve the desired performance.



Note You may not set the fan speeds or power settings lower than the minimum level required to maintain required cooling levels.

Complete the following steps to change the fan settings in MAX .

1. In the Configuration tree, click on the PXI chassis you want to configure.
2. In the right-hand pane, click on the Settings tab.
3. In the Fans group, select the desired Mode and Cooling Profile using the drop-down menus.
4. Click the Save button. Shortly after clicking the Save button, you should see the fan speeds change.

Using System Configuration and Initialization Files

The PXI Express specification allows many combinations of PXI Express chassis and system modules. To assist system integrators, the manufacturers of PXI Express chassis and system modules must document the capabilities of their products. The minimum documentation requirements are contained in `.ini` files, which consist of ASCII text. System integrators, configuration utilities, and device drivers can use these `.ini` files.

The capability documentation for the PXIe-1088 chassis is contained in the `chassis.ini` file on the software media that comes with the chassis. The information in this file is combined with information about the system controller to create a single system initialization file called `pxisys.ini` (PXI System Initialization). The system controller manufacturer either provides a `pxisys.ini` file for the particular chassis model that contains the system controller or provides a utility that can read an arbitrary `chassis.ini` file and generate the corresponding `pxisys.ini` file. System controllers from NI provide the `pxisys.ini` file for the PXIe-1088 chassis, so you should not need to use the `chassis.ini` file. Refer to the documentation provided with the system controller or to ni.com/support for more information on `pxisys.ini` and `chassis.ini` files.

Device drivers and other utility software read the `pxisys.ini` file to obtain system information. The device drivers should have no need to directly read the `chassis.ini` file. For detailed information regarding initialization files, refer to the PXI Express specification at www.pxisa.org.

Maintenance

This section describes basic maintenance procedures you can perform on the PXIe-1088 chassis.



Caution Disconnect the power cable prior to servicing your PXIe-1088 chassis.

Service Interval

Clean dust from the chassis exterior (and interior) as needed, based on the operating environment. Periodic cleaning increases reliability.

Preparation

The information in this section is designed for use by qualified service personnel. Read the ***Read Me First: Safety and Electromagnetic Compatibility*** document included with your kit before attempting any procedures in this section.



Note Many components within the chassis are susceptible to static discharge damage. Service the chassis only in a static-free environment. Observe standard handling precautions for static-sensitive devices while servicing the chassis. **Always** wear a grounded wrist strap or equivalent while servicing the chassis.

Cleaning

Cleaning procedures consist of exterior and interior cleaning of the chassis and cleaning the fan filters. Refer to your module's user documentation for information about cleaning individual CompactPCI or PXI Express modules.



Caution Always disconnect the power cable prior to servicing the chassis.

Interior Cleaning

Use a dry, low-velocity stream of air to clean the interior of the chassis. Use a soft-bristle brush for cleaning around components.

Exterior Cleaning

Clean the exterior surfaces of the chassis with a dry, lint-free cloth or a soft-bristle brush. If any dirt remains, wipe with a cloth moistened in a mild soap solution. Remove any soap residue by wiping with a cloth moistened with clear water. Do not use abrasive compounds on any part of the chassis.



Caution Avoid getting moisture inside the chassis during exterior cleaning, especially through the top vents. Use just enough moisture to dampen the cloth.

Do not wash the front- or rear-panel connectors or switches. Cover these components while cleaning the chassis.

Do not use harsh chemical cleaning agents; they may damage the chassis. Avoid chemicals that contain benzene, toluene, xylene, acetone, or similar solvents.

NI Services

Visit ni.com/support to find support resources including documentation, downloads, and troubleshooting and application development self-help such as tutorials and examples.

Visit ni.com/services to learn about NI service offerings such as calibration options, repair, and replacement.

Visit ni.com/register to register your NI product. Product registration facilitates technical support and ensures that you receive important information updates from NI.

NI corporate headquarters is located at 11500 N Mopac Expwy, Austin, TX, 78759-3504, USA.