

COMPREHENSIVE SERVICES

We offer competitive repair and calibration services, as well as easily accessible documentation and free downloadable resources.

SELL YOUR SURPLUS

We buy new, used, decommissioned, and surplus parts from every NI series. We work out the best solution to suit your individual needs.

 Sell For Cash  Get Credit  Receive a Trade-In Deal

OBSOLETE NI HARDWARE IN STOCK & READY TO SHIP

We stock **New**, **New Surplus**, **Refurbished**, and **Reconditioned** NI Hardware.



Bridging the gap between the manufacturer and your legacy test system.

 1-800-915-6216

 www.apexwaves.com

 sales@apexwaves.com

All trademarks, brands, and brand names are the property of their respective owners.

Request a Quote

 **CLICK HERE**

PXIe-8821

Manufacturer: National Instruments

Board Assembly Part Numbers (Refer to Procedure 1 for identification procedure):

Part Number and Revision	Description
142292A-011L or later	NI PXIE-8821, Localized OS
142292A-111L or later	NI PXIE-8821, Win 7 (64-BIT)
142292A-211L or later	NI PXIE-8821, Win 10 Pro (64-BIT)
142292A-251L or later	NI PXIE-8821, Win 10 Pro (64-BIT), Simplified Chinese
142292A-311L or later	NI PXIE-8821, Win IOT
142292A-351L or later	NI PXIE-8821, Win IOT, Simplified Chinese

Volatile Memory

<i>Target Data</i>	<i>Type</i>	<i>Size</i>	<i>Battery Backup</i>	<i>User¹ Accessible</i>	<i>System Accessible</i>	<i>Sanitization Procedure</i>
OS and User Data	DDR3L SDRAM	2+ GB	No	Yes	Yes	Cycle Power
PCH Real Time Clock (RTC)	CMOS	256B	Yes	Yes	Yes	Procedure 2

Non-Volatile Memory (incl. Media Storage)

<i>Target Data</i>	<i>Type</i>	<i>Size</i>	<i>Battery Backup</i>	<i>User Accessible</i>	<i>System Accessible</i>	<i>Sanitization Procedure</i>
Power Sequence & Data Logic	CPLD	2112 LUTs	No	No	Yes	None
Firmware Storage	SPI Flash	16MB	No			
• BIOS configuration				Yes	Yes	Procedure 3
• ME Firmware				No	Yes	None
• Primary Ethernet firmware				No	Yes	None
PCIe Switch Configuration	EEPROM	32KB	No	No	Yes	None
Primary Storage	Magnetic Disk	80+ GB	No	Yes	Yes	Procedure 4

¹ Refer to *Terms and Definitions* section for clarification of *User* and *System Accessible*

Procedures

Procedure 1 – Board Assembly Part Number identification:

To determine the Board Assembly Part Number and Revision, refer to label attached to controller.

Procedure 2 – PCH Real Time Clock (RTC) CMOS:

Use one of the following methods to reset the Real Time Clock CMOS.

1. First Method:
 - a) Power Off the chassis
 - b) Remove the controller from the chassis.
 - c) Press the 'Clear CMOS' button (SW1) shown in the figure for 2 to 3 seconds.

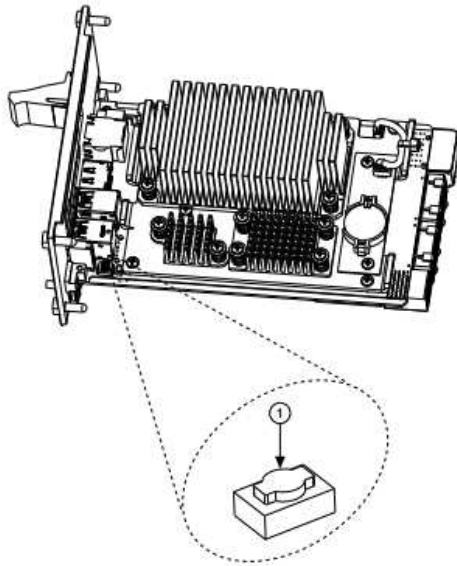

1. Push-Button Switch SW1

- d) Reinstall the controller in the chassis and power up as usual.
2. Second Method:
 - a) Power Off the chassis
 - b) Remove the controller from the chassis.
 - c) Remove the battery (coin-cell on the heatsink side of the controller) and wait for more than 10 seconds.
 - d) Reinstall the battery.
 - e) Reinstall the controller in the chassis and power up as usual.

Procedure 3 – Firmware Storage SPI Flash (BIOS Configuration):

To clear the user-accessible BIOS Configuration information in the Firmware Storage SPI Flash, perform a factory reset within BIOS setup.

Procedure 4 – Primary Storage SSD:

There are several alternatives for sanitizing the Primary Storage's contents. To sanitize the drive, perform one of the following steps:

1. Clear the disk using a commercially available utility for overwriting solid states disk drives.
2. Remove the disk and apply sanitization procedures acceptable to your organization. You can also replace the disk with a removable one so that the stored data can be disassociated from the controller at any time.

Terms and Definitions

Cycle Power:

The process of completely removing power from the device and its components and allowing for adequate discharge. This process includes a complete shutdown of the PC and/or chassis containing the device; a reboot is not sufficient for the completion of this process.

Volatile Memory:

Requires power to maintain the stored information. When power is removed from this memory, its contents are lost. This type of memory typically contains application specific data such as capture waveforms.

Non-Volatile Memory:

Power is not required to maintain the stored information. Device retains its contents when power is removed. This type of memory typically contains information necessary to boot, configure, or calibrate the product or may include device power up states.

User Accessible:

The component is read and/or write addressable such that a user can store arbitrary information to the component from the host using a publicly distributed NI tool, such as a Driver API, the System Configuration API, or MAX.

System Accessible:

The component is read and/or write addressable from the host without the need to physically alter the product.

Clearing:

Per *NIST Special Publication 800-88 Revision 1*, “clearing” is a logical technique to sanitize data in all User Accessible storage locations for protection against simple non-invasive data recovery techniques using the same interface available to the user; typically applied through the standard read and write commands to the storage device.

Sanitization:

Per *NIST Special Publication 800-88 Revision 1*, “sanitization” is a process to render access to “Target Data” on the media infeasible for a given level of effort. In this document, clearing is the degree of sanitization described.