



**Hewlett Packard
Enterprise**

HPE Edgeline EL1000 System User Guide

Abstract

This document is for the person who installs, administers, and troubleshoots servers and storage systems. Hewlett Packard Enterprise assumes you are qualified in the servicing of computer equipment and trained in recognizing hazards in products with hazardous energy levels.

Part Number: 868773-002
Published: May 2017
Edition: 2

Notices

The information contained herein is subject to change without notice. The only warranties for Hewlett Packard Enterprise products and services are set forth in the express warranty statements accompanying such products and services. Nothing herein should be construed as constituting an additional warranty. Hewlett Packard Enterprise shall not be liable for technical or editorial errors or omissions contained herein.

Confidential computer software. Valid license from Hewlett Packard Enterprise required for possession, use, or copying. Consistent with FAR 12.211 and 12.212, Commercial Computer Software, Computer Software Documentation, and Technical Data for Commercial Items are licensed to the U.S. Government under vendor's standard commercial license.

Links to third-party websites take you outside the Hewlett Packard Enterprise website. Hewlett Packard Enterprise has no control over and is not responsible for information outside the Hewlett Packard Enterprise website.

Acknowledgments

Intel[®], Itanium[®], Pentium[®], Intel Inside[®], and the Intel Inside logo are trademarks of Intel Corporation in the United States and other countries.

Microsoft[®] and Windows[®] are either registered trademarks or trademarks of Microsoft Corporation in the United States and/or other countries.

Linux[™] is the registered trademark of Linus Torvalds in the U.S. and other countries.

SD[™] and microSD[™] are trademarks or registered trademarks of SD-3C in the United States, other countries or both.

NVIDIA[™] is a trademark of NVIDIA Corporation in the U.S. and other countries.

Contents

Component identification.....	6
PCIe configuration.....	6
Front panel components.....	6
Front panel LEDs and buttons.....	6
Right side components.....	7
System board components.....	8
PXI/PXIe configuration.....	8
Front panel components.....	8
Front panel LEDs and buttons.....	9
Right side components.....	10
System board components.....	10
DIP switch.....	11
Hot-plug drive LED definitions.....	11
Operations.....	13
Install an AC power supply.....	13
Install the DC power supply.....	13
Power down the system.....	17
Power up the system.....	18
Mount the system.....	18
Dismount the system.....	18
Dismounting the system from a wall mount.....	18
Dismounting the system from a rack mount.....	19
Dismounting the system from an ETSI rack mount.....	19
Dismounting the system from an Enterprise rack mount.....	19
Remove the access panel.....	19
Installing the fans.....	20
Installing the cartridge.....	20
Install the mini-PCIe adapter board.....	21
Setup.....	22
Optional services.....	22
Optimum environment.....	22
Temperature requirements.....	22
Power requirements.....	22
Installing hardware options	23
Registering the product.....	23
Hardware options installation.....	24
Installing the wall mounting option kit.....	24
Installing the rack mounting option kit.....	24
Installing the ETSI rack mounting option kit.....	25
Installing the Enterprise rack mounting option kit.....	26
Installing the drive.....	28
Installing the card options.....	28
Install the PCIe card.....	28

Install the PXI/PXIe card	30
Installing the mini-PCIe module options.....	31
Install a half-length mini-PCIe module option.....	31
Installing a full-length mini-PCIe module.....	32
Configuration	33
Accessing the System Utilities menu.....	33
Viewing or updating the DHCP address using the serial console cable.....	34
Finding the IP address through DHCP.....	34
Setting the static IP address using the serial console cable.....	35
Software and configuration utilities	37
Product QuickSpecs.....	37
Supported operating systems and drivers matrix	37
HPE iLO.....	37
Active Health System.....	37
Active Health System data collection.....	38
Active Health System log.....	38
iLO RESTful API support.....	38
Integrated Management Log.....	39
HPE Edgeline Component Pack.....	39
HP Smart Update Manager.....	39
UEFI System Utilities.....	39
Using UEFI System Utilities.....	40
Flexible boot control.....	40
Restoring and customizing configuration settings.....	41
Secure Boot configuration.....	41
Embedded UEFI shell.....	41
Embedded Diagnostics option.....	41
iLO RESTful API support for UEFI.....	42
Re-entering the server serial number and product ID.....	42
Troubleshooting	43
HPE Edgeline Troubleshooting Guide.....	43
Battery	44
Battery specifications.....	44
Replace the system battery.....	44
Warranty and regulatory information	46
Warranty information.....	46
Regulatory information.....	46
Safety and regulatory compliance.....	46
Belarus Kazakhstan Russia marking.....	46
Turkey RoHS material content declaration.....	47
Ukraine RoHS material content declaration.....	47
Electrostatic discharge	48
Preventing electrostatic discharge.....	48
Grounding methods to prevent electrostatic discharge.....	48

Specifications.....	49
Product QuickSpecs.....	49
Environmental specifications	49
Environmental specifications-system components support matrix.....	51
Mechanical specifications.....	51
Power supply specifications.....	51
PXI/PXIe specifications.....	53
Electrical load regulation specifications.....	53
Chassis cooling specifications.....	53
Pollution specifications.....	53
Shock and vibration specifications.....	53
Acoustic emission specifications	53
HPE EMC compliance testing.....	55
System synchronization clock specifications.....	55
 Support and other resources.....	 57
Websites.....	57
Accessing Hewlett Packard Enterprise Support.....	57
Information to collect.....	57
Accessing updates.....	58
Customer self repair.....	58
Remote support.....	58
 Acronyms and abbreviations.....	 60
 Documentation feedback.....	 61

Component identification

PCIe configuration

Front panel components

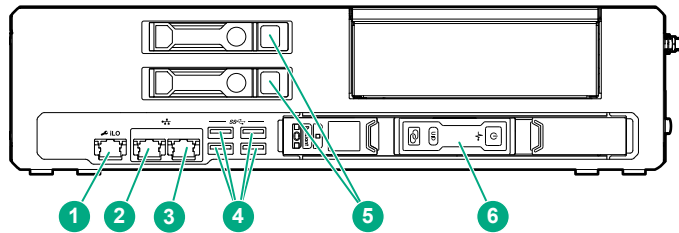

Item	Description
1	iLO port
2	Network port 1 ¹
3	Network port 2 ¹
4	USB 3.0 ports
5	Drives
6	Cartridge

¹ Network connections are available in 1G and 10G. The 1G is shown.

Front panel LEDs and buttons

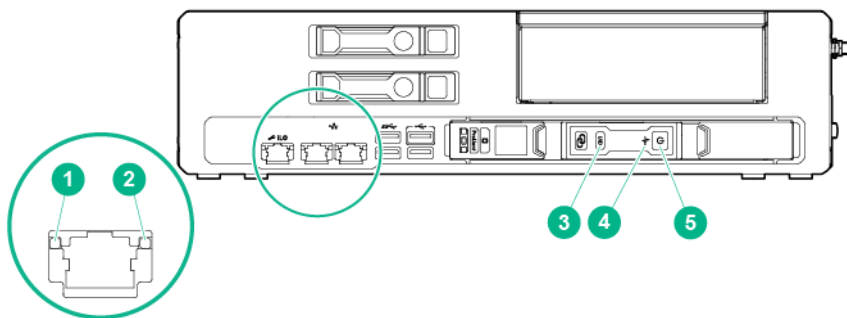

Item	Description	Status
1	iLO and network port link LED	<ul style="list-style-type: none">• Green = Linked to network• Off = No network connection
2	iLO and network port activity LED	<ul style="list-style-type: none">• Flashing green = Network activity• Off = No network activity

Table Continued

Item	Description	Status
3	Cartridge UID LED/button	<ul style="list-style-type: none"> Blue = Cartridge ID is selected Flashing Blue = Cartridge firmware update is in progress or iLO IRC is in use Off = Cartridge ID is not selected
4	Cartridge health LED	<ul style="list-style-type: none"> Green = Normal operation Flashing Amber = Degraded condition Flashing Red = Critical condition Off = No power
5	Cartridge power LED	<ul style="list-style-type: none"> Green = Normal operation Flashing green = iLO booting Amber = Standby operation Off = No power

Right side components

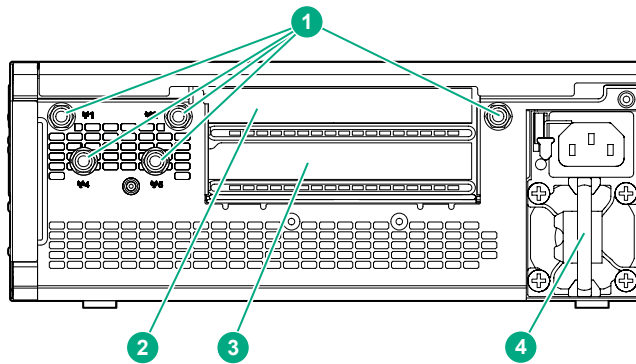

Item	Description
1	Antenna connectors
2	PCIe slot 1
3	PCIe slot 2
4	Power supply

System board components

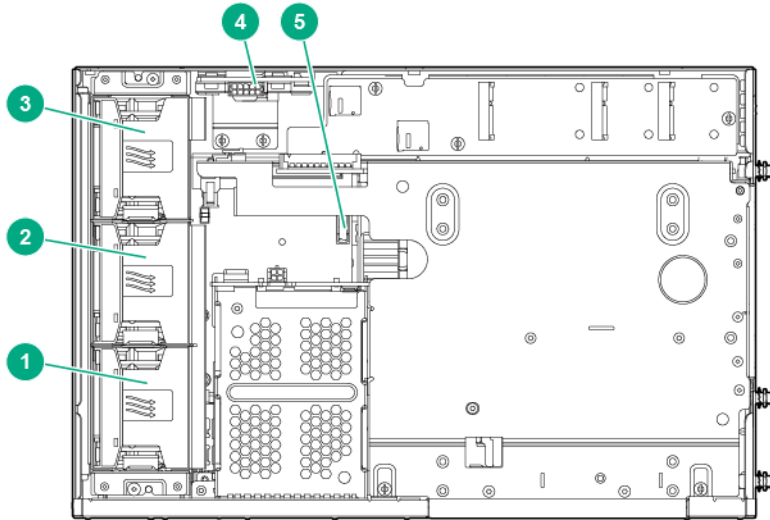

Item	Description
1	Fan 1
2	Fan 2
3	Fan 3
4	Power distribution board
5	System battery

PXI/PXle configuration

Front panel components

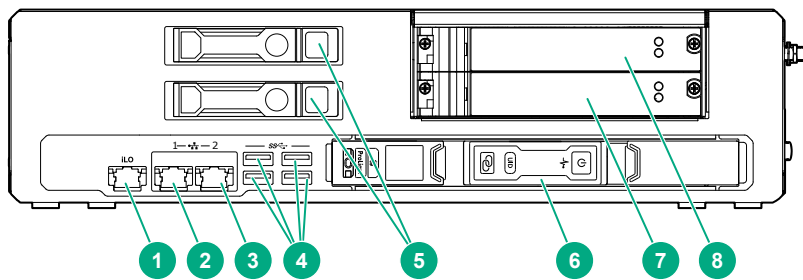

Item	Description
1	iLO port
2	Network port 1 ¹
3	Network port 2 ¹

Table Continued

Item	Description
4	USB 3.0 ports (4)
5	Drives (2)
6	Cartridge
7	PXI/PXIe slot 3
8	PXI/PXIe slot 2

¹ Network connections are available in 1G and 10G. The 1G is shown.

Front panel LEDs and buttons

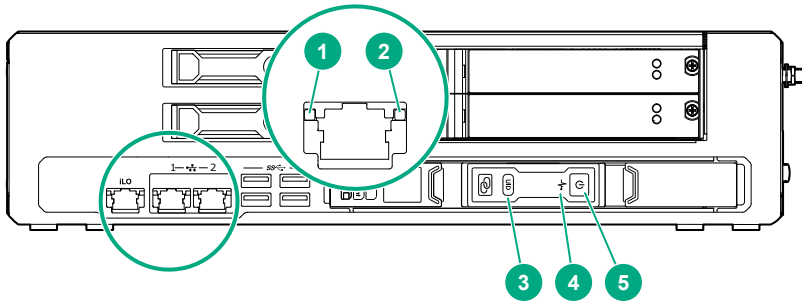

Item	Description	Status
1	iLO and network port link LED	<ul style="list-style-type: none"> Green = Linked to network Off = No network connection
2	iLO and network port activity LED	<ul style="list-style-type: none"> Flashing green = Network activity Off = No network activity
3	Cartridge UID LED/button	<ul style="list-style-type: none"> Blue = Cartridge ID is selected Flashing Blue = Cartridge firmware update is in progress or iLO IRC is in use Off = Cartridge ID is not selected
4	Cartridge health LED	<ul style="list-style-type: none"> Green = Normal operation Flashing Amber = Degraded condition Flashing Red = Critical condition Off = No power
5	Cartridge power LED	<ul style="list-style-type: none"> Green = Normal operation Flashing green = iLO booting Amber = Standby operation Off = No power

Right side components

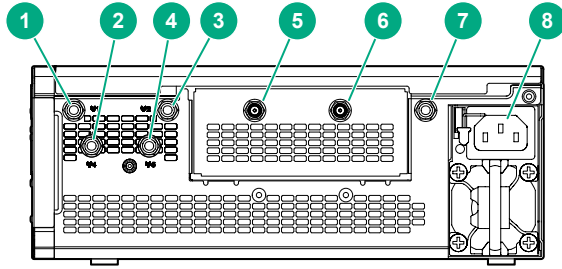

Item	Description
1	Antenna connector
2	Antenna connector
3	Antenna connector
4	Antenna connector
5	REF in connector
6	REF out connector
7	Antenna connector
8	Power supply

System board components

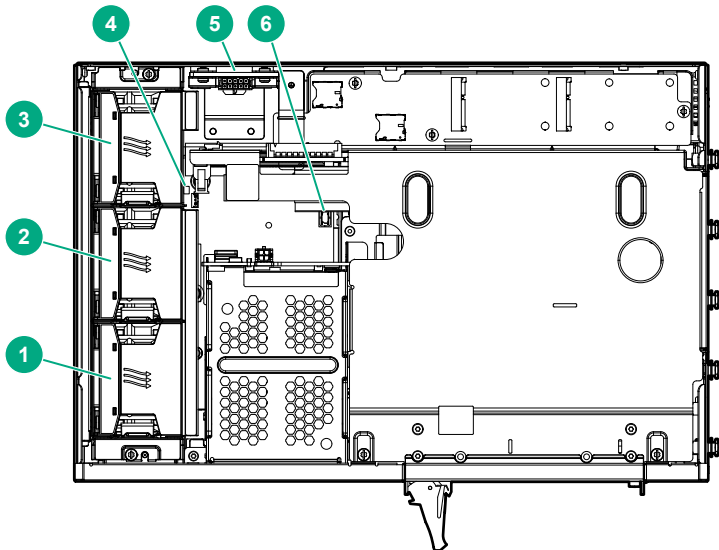

Item	Description
1	Fan 1
2	Fan 2

Table Continued

Item	Description
3	Fan 3
4	DIP Switch ¹
5	Power distribution board
6	System battery

¹ The fan cage might have to be removed to access the switch

DIP switch

Position	Default	Function
S1	Off	<ul style="list-style-type: none"> Off = Fan normal mode On = Fan high mode

Hot-plug drive LED definitions

When a drive is configured as part of a SmartArray and connected to a powered-up controller, the drive LEDs indicate the condition of the drive. If no SmartArray adapter is present, then these drives will not be hot pluggable, but will still show the activity LEDs.

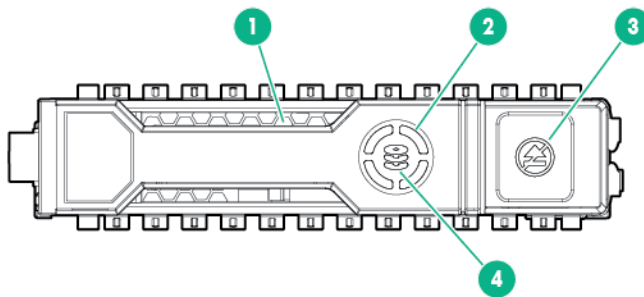

Item	LED	Status	Definition
1	Locate	Solid blue	The drive is being identified by a host application.
		Flashing blue	The drive carrier firmware is being updated or requires an update.
2	Activity ring	Rotating green	Drive activity
		Off	No drive activity
3	Do not remove	Solid white	Do not remove the drive. Removing the drive causes one or more of the logical drives to fail.
		Off	Removing the drive does not cause a logical drive to fail.

Table Continued

4	Drive status	Solid green	The drive is a member of one or more logical drives.
		Flashing green	The drive is rebuilding or performing a RAID migration, strip size migration, capacity expansion, or logical drive extension, or is erasing.
		Flashing amber/green	The drive is a member of one or more logical drives and predicts the drive will fail.
		Flashing amber	The drive is not configured and predicts the drive will fail.
		Solid amber	The drive has failed.
		Off	The drive is not configured by a RAID controller.

Operations

This chapter describes the hardware operations carried out prior to and after installing or removing a hardware option, or performing a server maintenance or troubleshooting procedure.

Before performing these hardware operations, review and observe the server warnings and cautions.

Install an AC power supply

Procedure

1. Align the power supply to the system.
2. Insert the power supply until it locks in place.

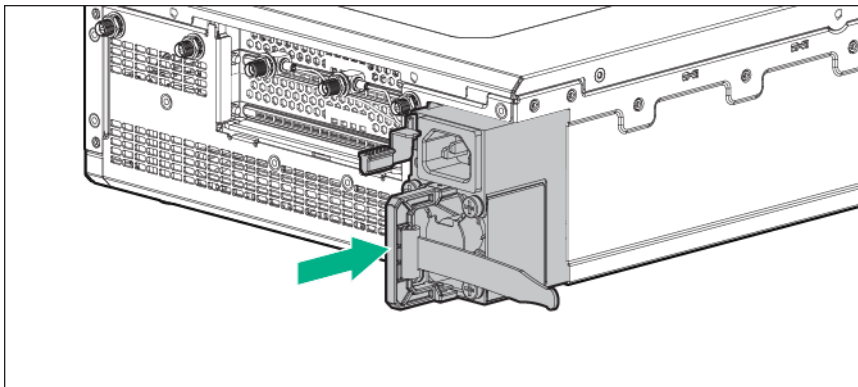

3. Connect the power cord and tie wrap the cable.

Install the DC power supply

Procedure

1. Remove the ring tongue from the top of the power supply.

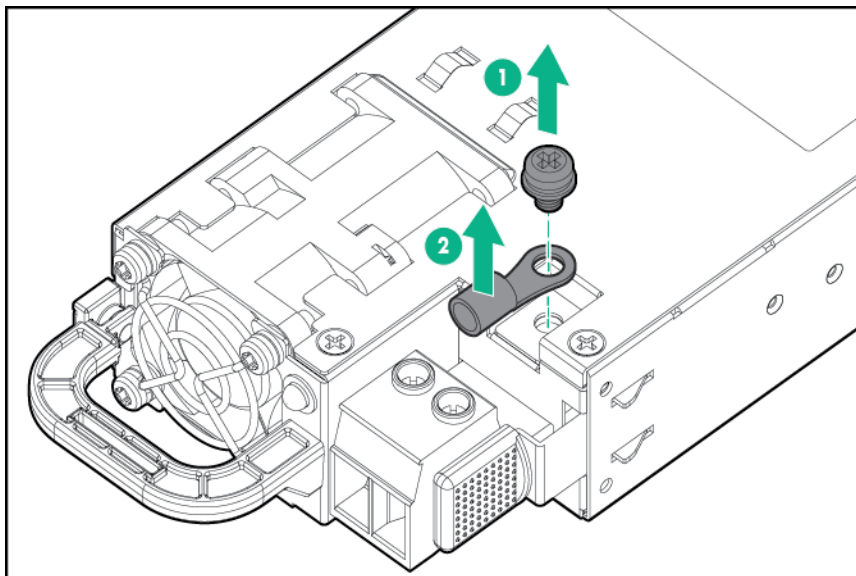

2. Crimp the ring tongue to the ground cable from the -48V power source.

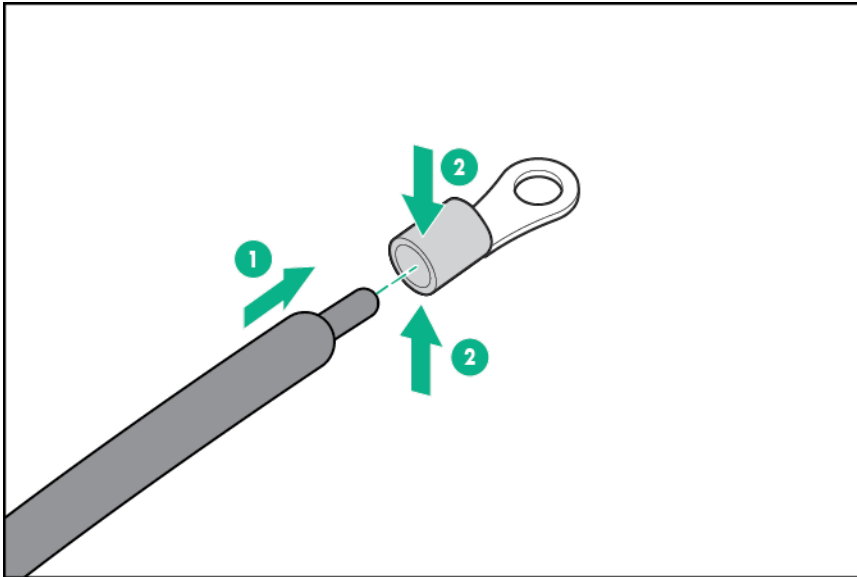

3. Remove the black connector from the rear of the power supply.

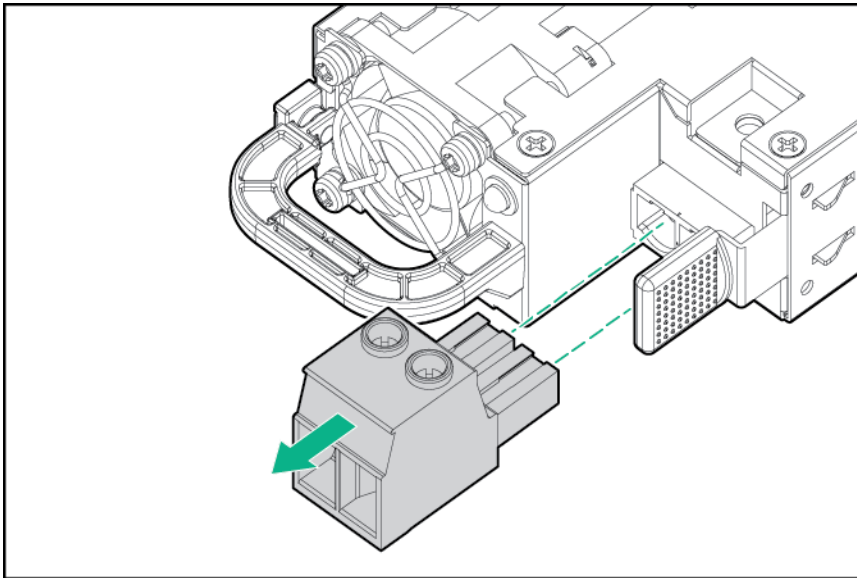

4. Loosen the screws on the connector.

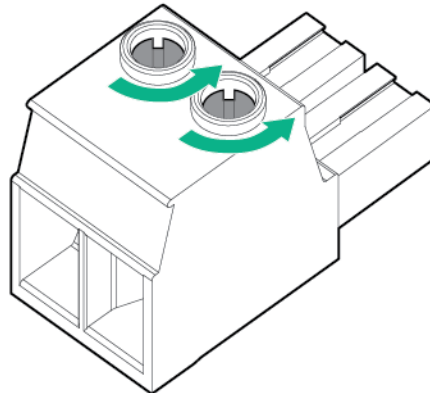

5. Attach the (earthed) cable to the ground screw and washer and tighten to 13 lb-in of torque. The ground cable must be connected before connecting the -48V wire and return wire.

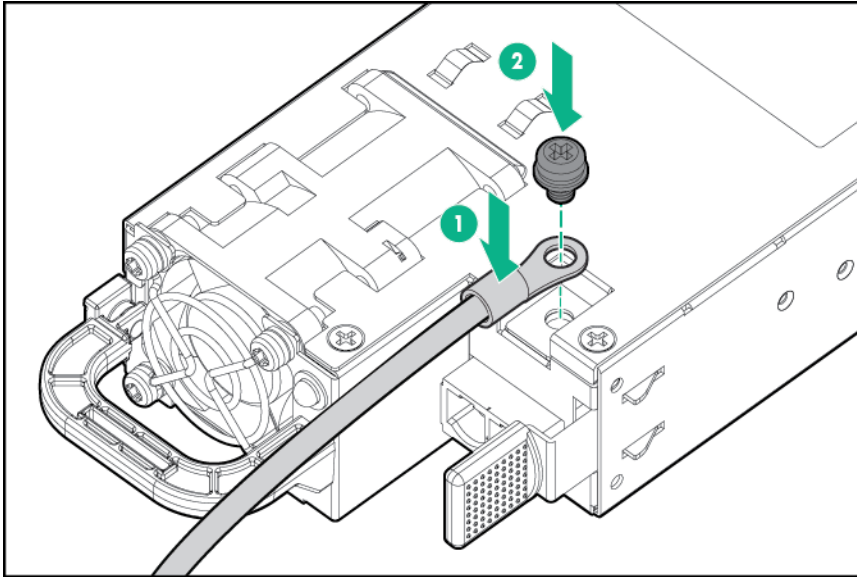

6. Insert the -48V wire into the left side of the connector and tighten the screw to 10 lb-in of torque.

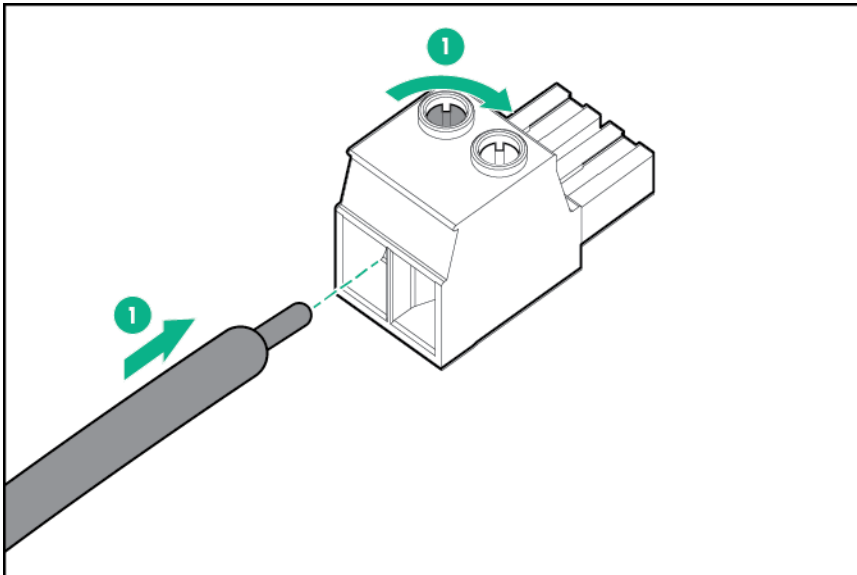

7. Insert the return wire into the right side of the connector and tighten the screw to 10 lb-in of torque.

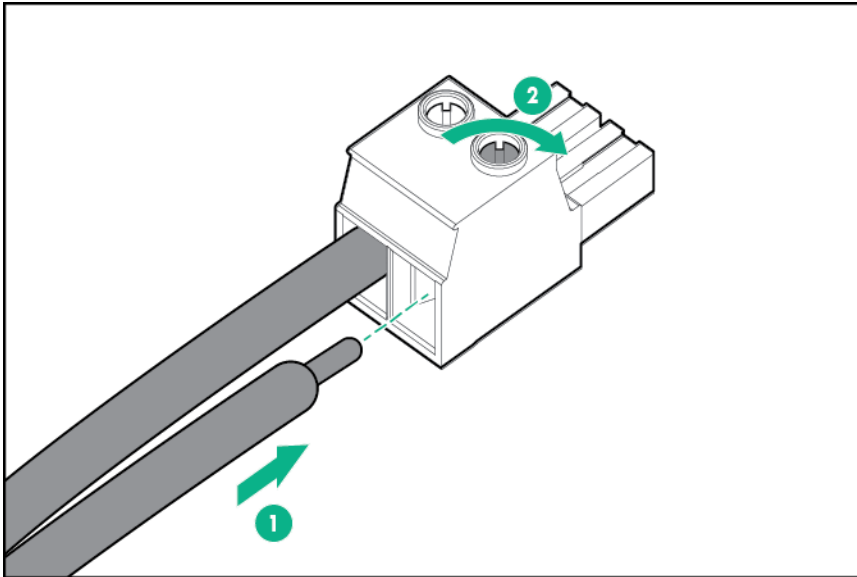

8. Insert the power supply into the power supply bay until it clicks into place.

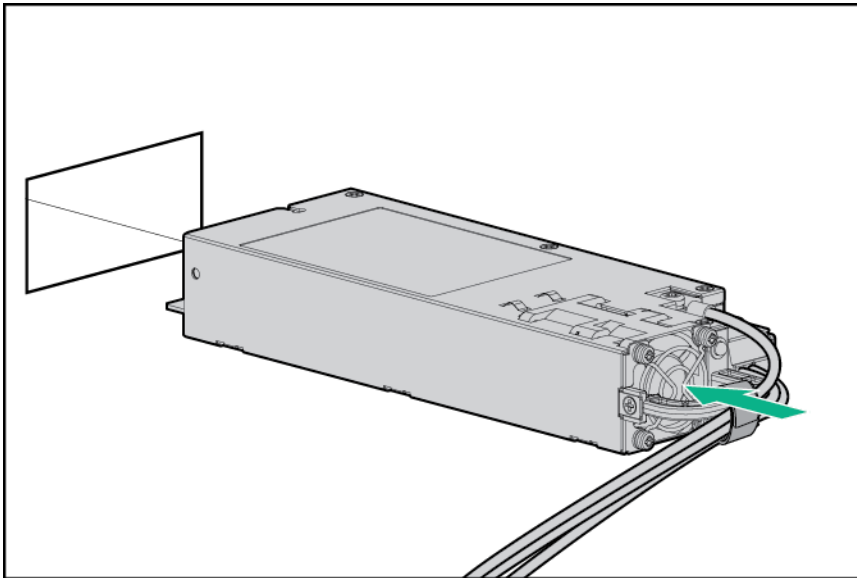

9. Insert the connector into the power supply.

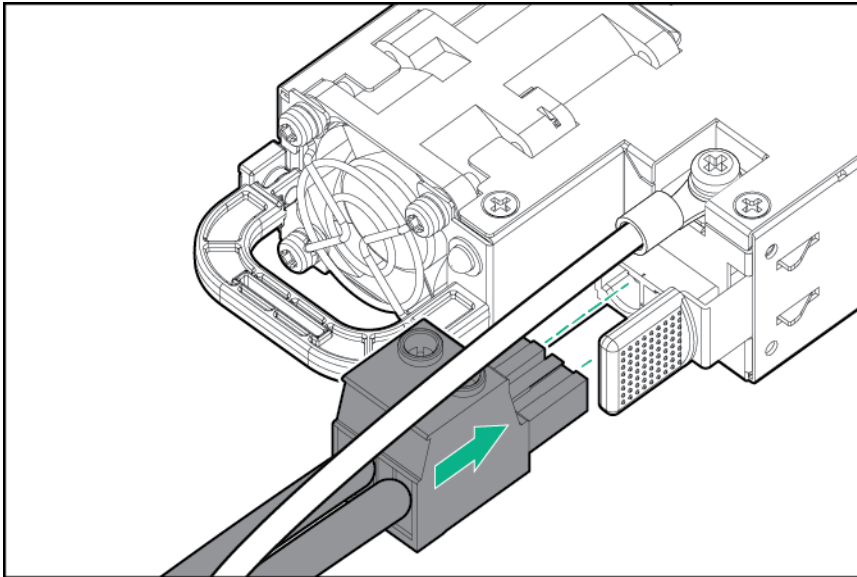

10. Attach the cables to the power supply handle with the hook-and-loop strap.

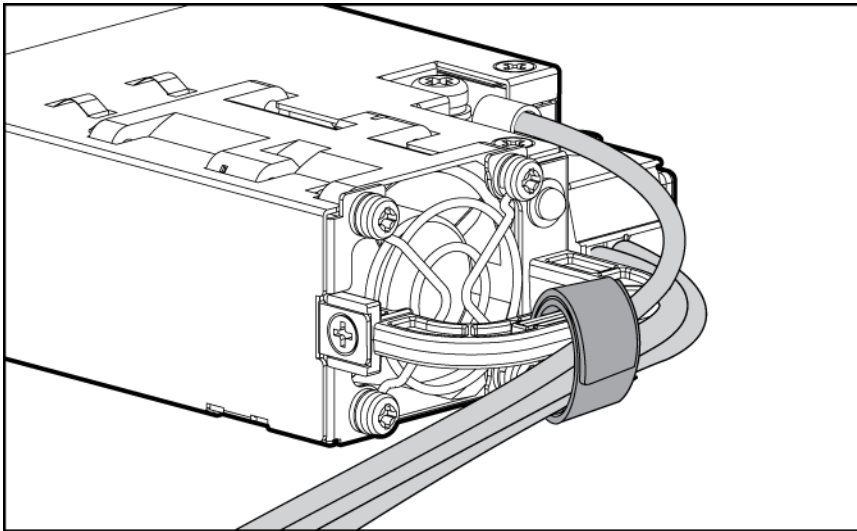

11. Route the power cord. Use best practices when routing power cords and other cables. A cable management arm is available to help with routing. To obtain a cable management arm, contact a Hewlett Packard Enterprise authorized reseller.
12. Make sure the -48V DC power source is off or the PDU breaker is in the off position, and then connect the power cord to the -48V DC power source or PDU.
13. Turn on the -48V power source or switch the PDU breaker to the on position to supply -48V to the power supply.
14. Be sure that the green power supply LED is on.

Power down the system

About this task

Before powering down the system for any upgrade or maintenance procedures, back up critical system data and programs.

Before performing chassis maintenance, shut down all cartridges installed in the system.

Procedure

- Use one of the following methods to power down the system:
 - Press and release the Power On/Standby button of the cartridges installed in the system.
This method initiates a controlled shutdown of applications and the OS before the system enters standby mode.
 - Press and hold the Power On/Standby button of the cartridges installed in the system for more than 4 seconds to force the system to power down.
This method forces the system to power down without properly exiting applications and the OS. If an application stops responding, you can use this method to force a shutdown.

Verify the system is in standby mode and the system power LED is off.

Power up the system

About this task

If the system is connected to a power source, it powers up automatically by default. Generally, it has to be powered up only after a manual shutdown. However, using iLO, cartridges can be individually configured to not power up automatically.

Procedure

- Use one of the following methods to power up the system:
 - Press the Power On/Standby button of the cartridge installed in the system.
 - Remotely power up the system through iLO.

Mount the system

The following kits are available to mount your system:

- [Wall mounting kit](#)
- [Rack mounting kit](#)
- [ETSI rack mounting kit](#)
- [Enterprise rack mounting kit](#)

Dismount the system

Dismount the system, based on the mount installed:

- [Dismounting the system from a wall mount](#)
- [Dismounting the system from a rack mount](#)
- [Dismounting the system from an ETSI rack mount](#)
- [Dismounting the system from an Enterprise rack mount](#)

Dismounting the system from a wall mount

About this task

To dismount the system from a wall mount, slide the EL1000 system off the wall-mounting screws.

It is not necessary to remove the wall mounting plate from the EL1000 system. Hewlett Packard Enterprise recommends having a cart to place the system upon, which allows you to service the system without removing the wall mounting plate or cables.

Should you need to service the system in another location, perform the following steps.

Procedure

1. Remove the four T-15 Torx screws securing the wall mounting plate to the bottom of the system.

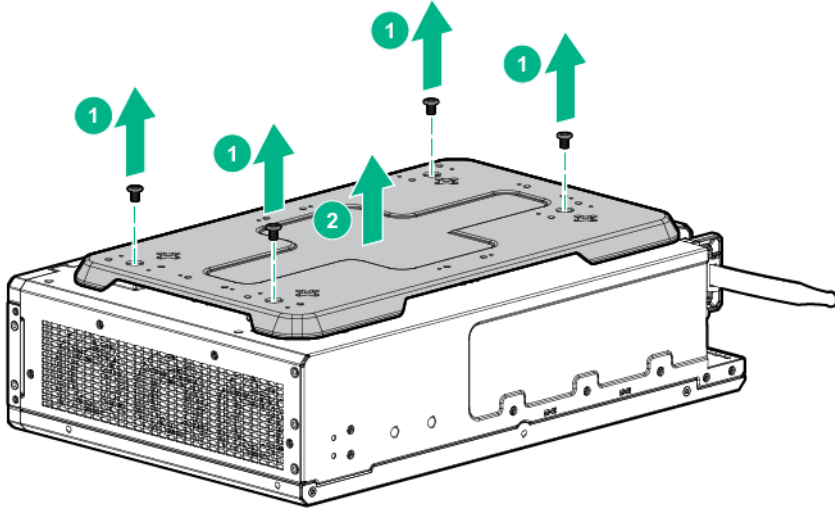

2. Disconnect all cables.

Dismounting the system from a rack mount

Procedure

1. Loosen the 2 captive screws on the front of rack mount shelf.
2. Slide the EL1000 system and shelf out from the rack mounts to the front.
3. Unplug the power cable and disconnect all cables from the system.
4. Remove the system from the shelf assembly by lifting vertically.

Dismounting the system from an ETSI rack mount

Procedure

1. Loosen the 2 captive screws on the front of rack mount shelf.
2. Slide the EL1000 system and shelf out from the rack mounts to the front.
3. Unplug the power cable and disconnect all cables from the system.
4. Remove the system from the shelf assembly by lifting vertically.

Dismounting the system from an Enterprise rack mount

Procedure

1. Slide the system out of the rack.
2. Unplug the power cable and disconnect all cables from the system.
3. Remove the retention bracket from the Enterprise rack mount.
4. Lift and remove the system from the rack mount.

Remove the access panel

Procedure

- Using a Torx driver, remove the two T10 Torx screws securing the access panel to the system.

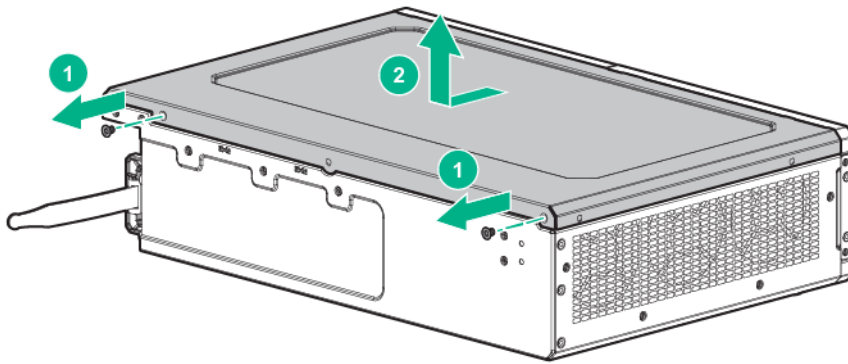

Installing the fans

Procedure

1. Align the fan with the fan slots of the system.
2. Squeeze the tabs on either side of the fan, and then slide it into the bay until it clicks in place.

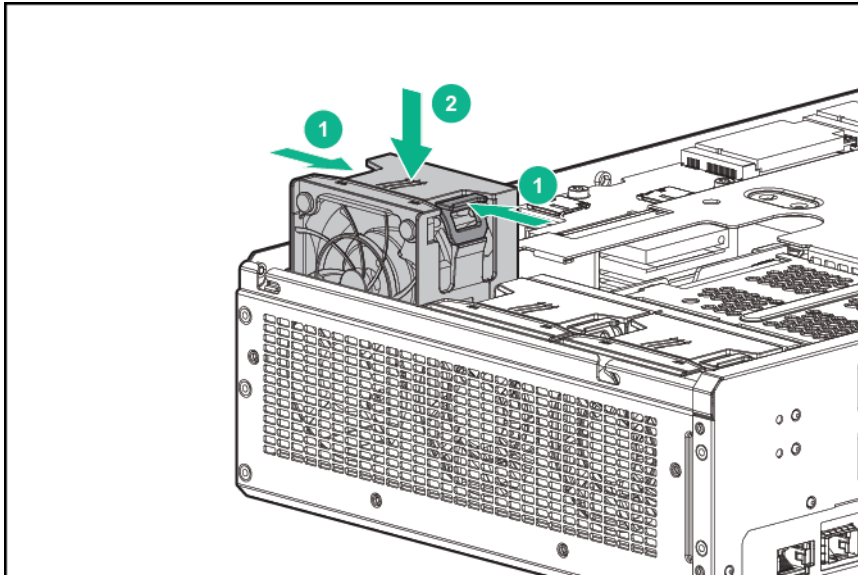

Installing the cartridge

About this task

No cartridges supported on the system support Legacy BIOS Boot mode. For more information, see the user and maintenance guide for your cartridge.

Procedure

- Align and install the cartridge into the system.

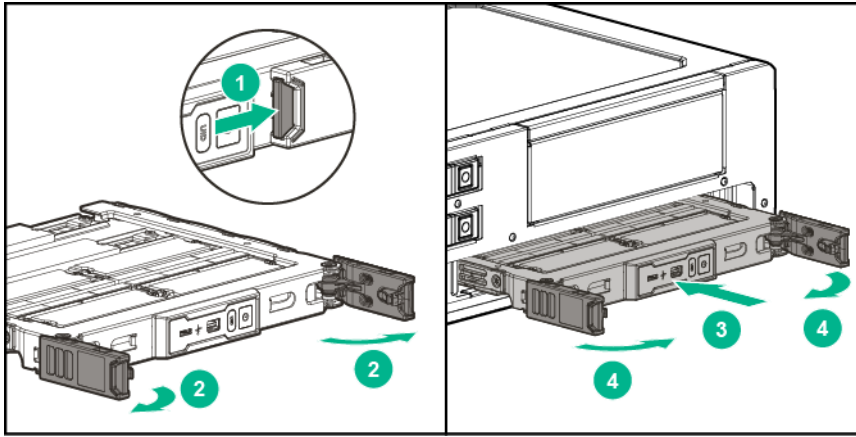

Install the mini-PCle adapter board

Procedure

1. Align the mini-PCle adapter board to the system board.
2. Using a Torx driver, insert and tighten the three T-15 Torx screws to secure the adapter board to the system board.

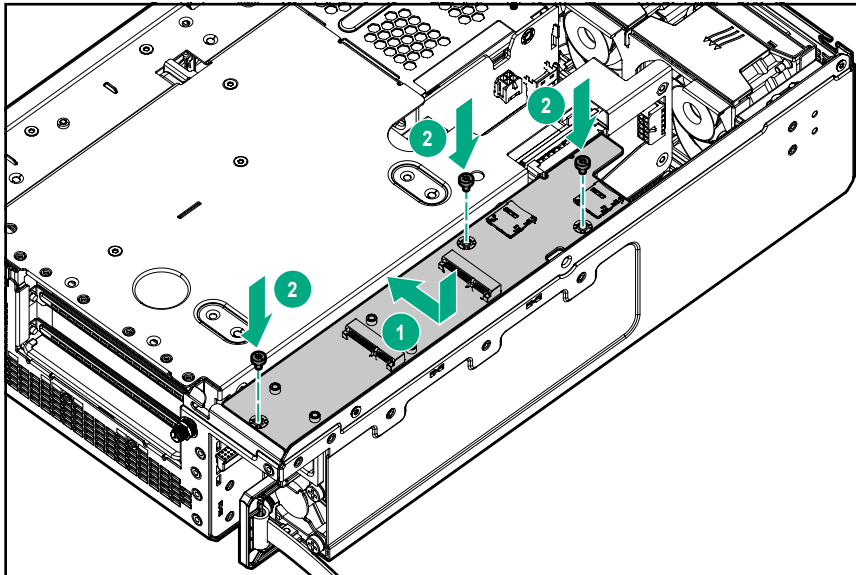

3. Connect the two cables from the mini-PCle adapter board to the system board:
 - a. Connect the power cable.
 - b. Connect the drive cable.

Setup

This chapter describes the initial setup procedures to prepare the server for operation.

Optional services

Hewlett Packard Enterprise offers the HPE Foundation Care Next Business Day Exchange Service for this product.

HPE Foundation Care Next Business Day Exchange Service provides a replacement product or part delivered free of freight charges to your location the next business day after a call is opened and provides support 24 hours per day, Monday through Sunday.

Hardware exchange offers a reliable and fast parts exchange service for eligible Hewlett Packard Enterprise products. Specifically targeted at products that can easily be shipped and on which you can easily restore data from backup files, HPE Foundation Care Next Business Day Exchange is a cost-efficient and convenient alternative to onsite support.

Replacement products or parts are new or equivalent to new in performance.

In addition, HPE Foundation Care Next Business Day Exchange provides electronic access to related product and support information, enabling any member of your IT staff to locate commercially available essential information.

For more information on HPE Foundation Care Next Business Day Exchange Service, see the [Hewlett Packard Enterprise website](#).

Optimum environment

When installing the system, select a location that meets the environmental standards.

- [Temperature requirements](#)
- [Power requirements](#)

Temperature requirements

To ensure continued safe and reliable equipment operation, install or position the system in a well-ventilated, climate-controlled environment.

Configuration	Temperature
Chassis with cartridges installed, but no PCIe cards/PXle modules installed	Operating temperature of up to 55°C (131°F)

Power requirements

Installation of this equipment must comply with local and regional electrical regulations governing the installation of information technology equipment by licensed electricians. This equipment is designed to operate in installations covered by NFPA 70, 1999 Edition (National Electric Code) and NFPA-75, 1992 (code for Protection of Electronic Computer/Data Processing Equipment). For electrical power ratings on options, see the product rating label or the user documentation supplied with that option.

More Information

[Power supply specifications](#) on page 51

Installing hardware options

Install any hardware options before initializing the system. For options installation information, see the option documentation. For system-specific information, see "[Hardware options installation](#)."

Registering the product

To experience quicker service and more efficient support, register the product at the [Hewlett Packard Enterprise Product Registration website](#).

Hardware options installation

Installing the wall mounting option kit

Procedure

1. Using the wall mount bracket, mark the locations for the wall mount screws.
2. Install the wall mount anchors and screws in the marked locations.
3. Align the wall mount bracket to the system.
4. Using a Torx driver, insert and tighten four T15 Torx screws to secure the bracket to the system.

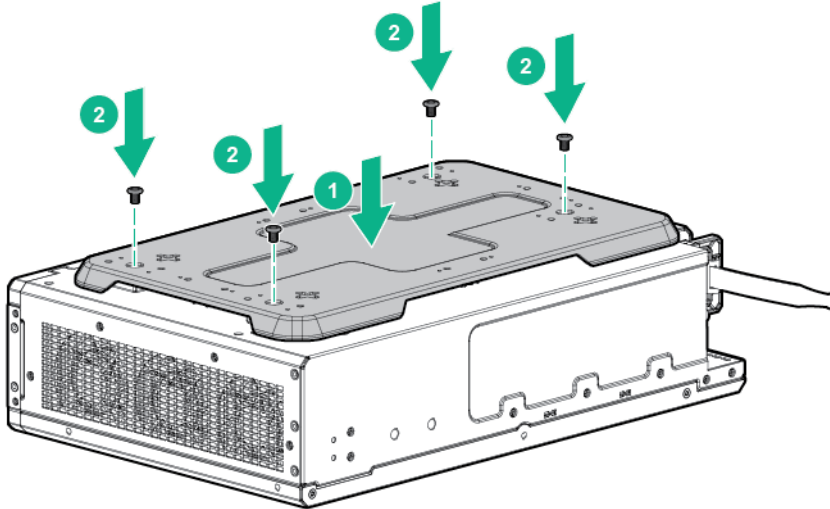

5. Place the holes in the wall mount bracket over the wall mounting screws and slide to lock into place.

Installing the rack mounting option kit

Procedure

1. Align the rack mount bracket to the system.
2. Using a Torx driver, insert and tighten four T-10 Torx screws to secure the bracket to the system.

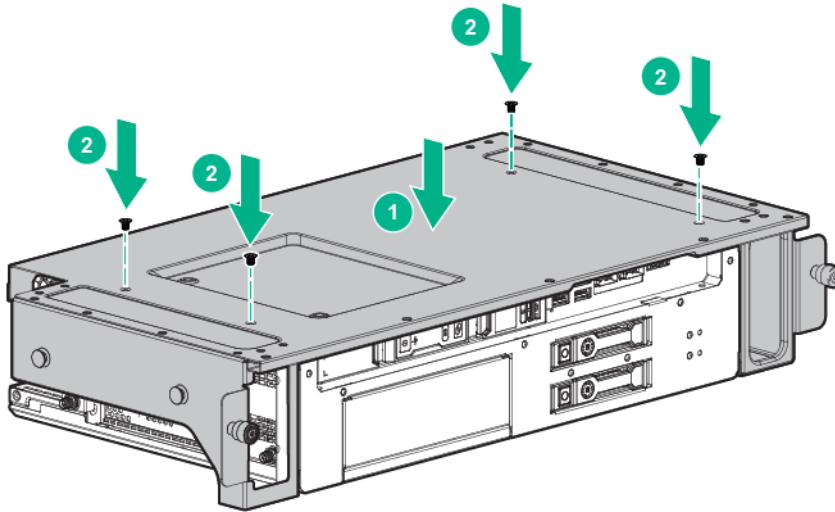

3. Install the system in the rack mount.

Installing the ETSI rack mounting option kit

Procedure

1. Align the rack mount bracket to the system.
2. Using a Torx driver, insert and tighten four T-10 Torx screws to secure the bracket to the system.

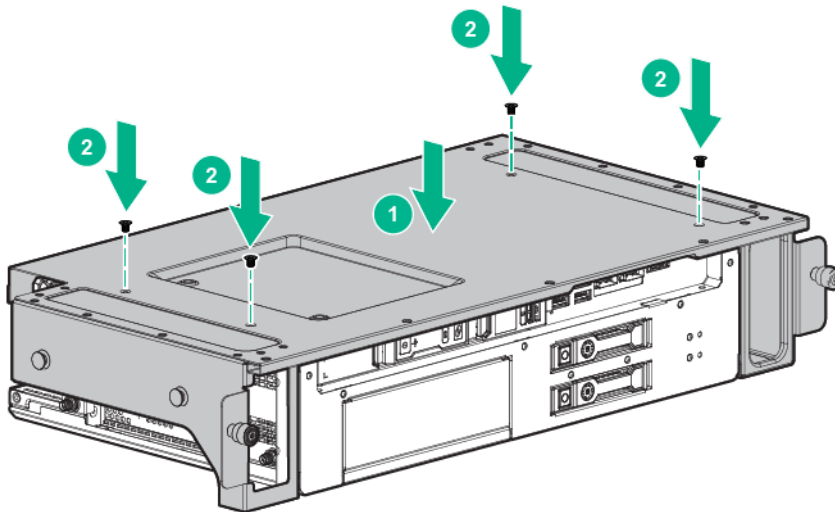

3. Install the ETSI brackets to the rack:
 - a. Align the bracket to the rack rail.
 - b. Using a Torx driver, insert and tighten two T-20 Torx screws to secure each bracket to the rack rail.

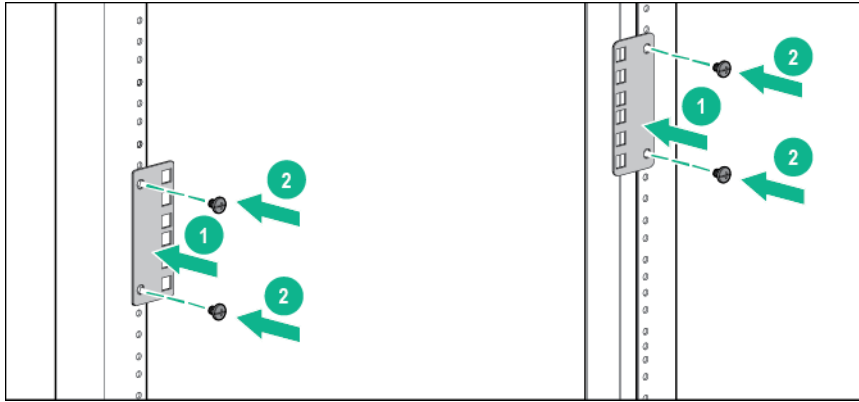

4. Align the system to the ETSI bracket.
5. Secure the system in the ETSI rack mount.

Installing the Enterprise rack mounting option kit

Procedure

1. Install the rails on the rack.

For more information on installing the rack rails, see the *Quick Deploy Rail System Installation Instructions* that ships with the rack hardware kit.

2. Install the cable management arm.

For more information on installing the cable management arm, see the *HP 1U Cable Management Arm Option Installation Instructions* that ships with the cable management arm kit.

3. Install the Enterprise rack mount onto the rails.

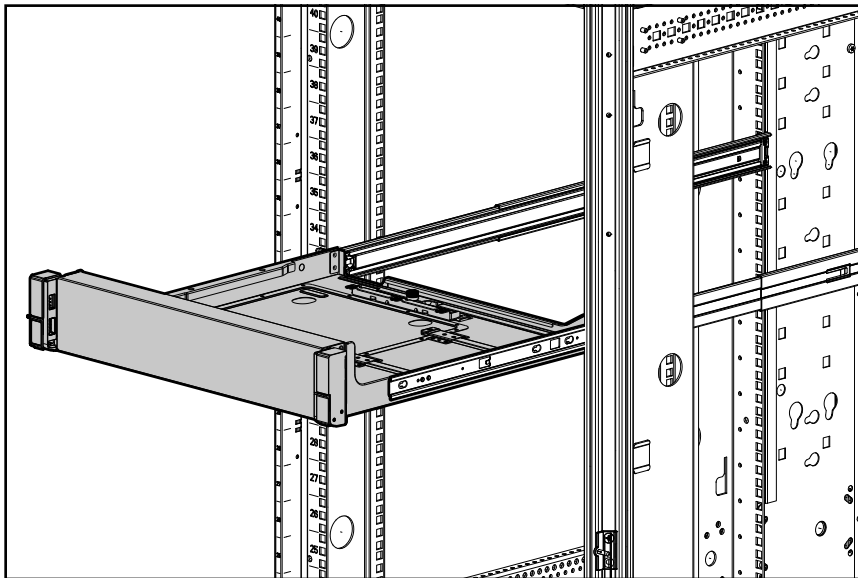

4. Remove the system retention bracket from the Enterprise rack mount.

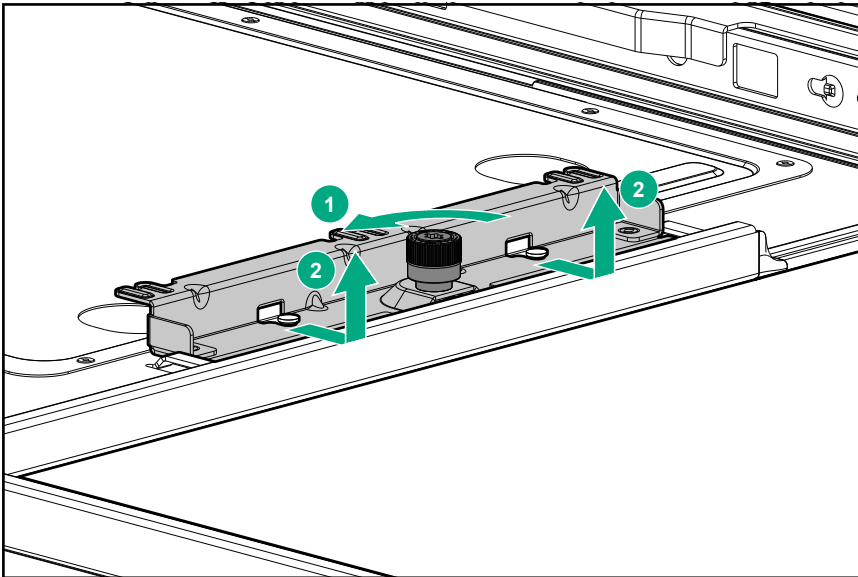

5. Align and install the system.

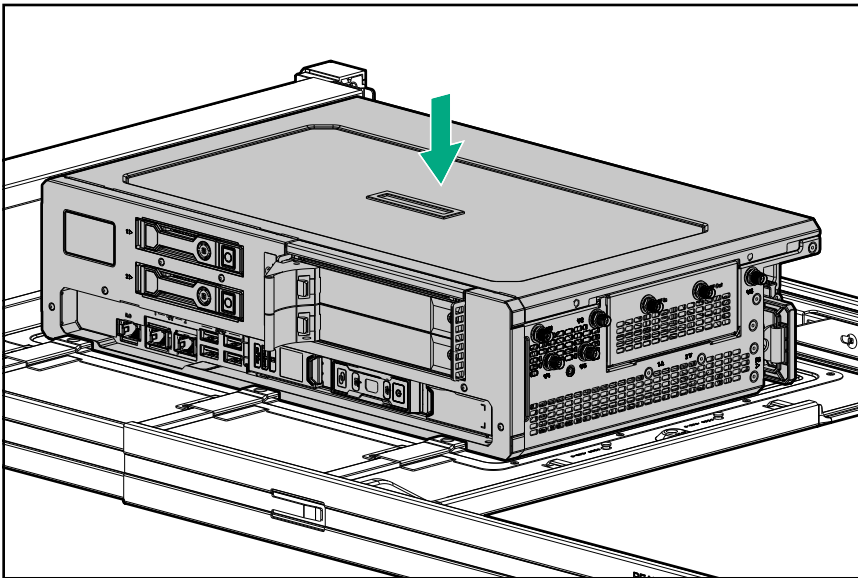

6. Install the retention bracket.

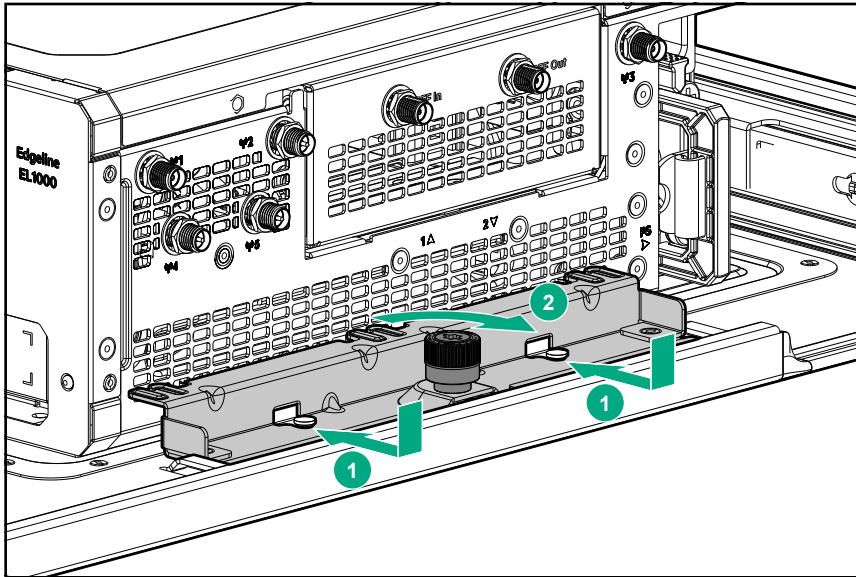

Installing the drive

Procedure

1. Align the drive to the drive bay, and slide it into the bay until it clicks in place.
2. Close the locking latch to secure the drive.

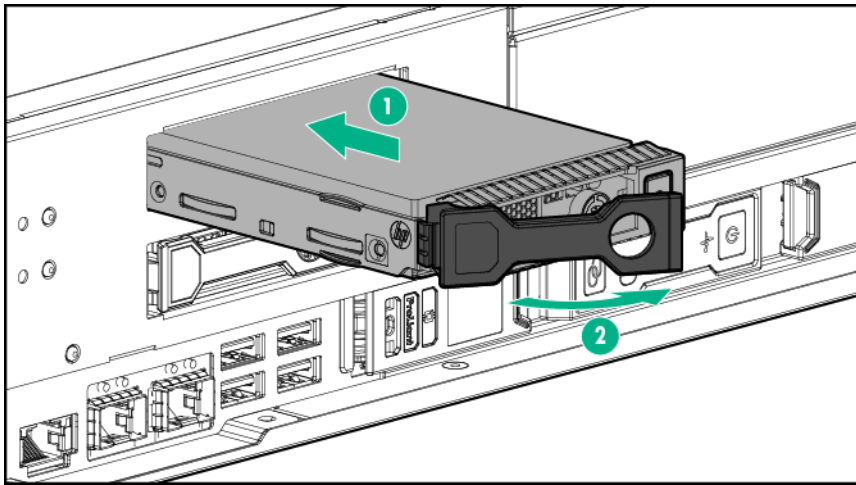

Installing the card options

Depending on the configuration of your system, perform one of the following procedures:

- **Install the PCIe card**
- **Install the PXI/PXIe card**

Install the PCIe card

About this task

The system supports optional PCIe cards.



IMPORTANT:

The PCIe card is not hot-pluggable. The system must be powered down to install this card.

Procedure

1. Remove power from the system.
2. If installed, remove the cartridge.
3. **Remove the access panel.**
4. Using a Torx driver, remove the three black T-15 Torx screws.
5. Lift the PCIe riser cage using the finger hold positions in the riser cage.

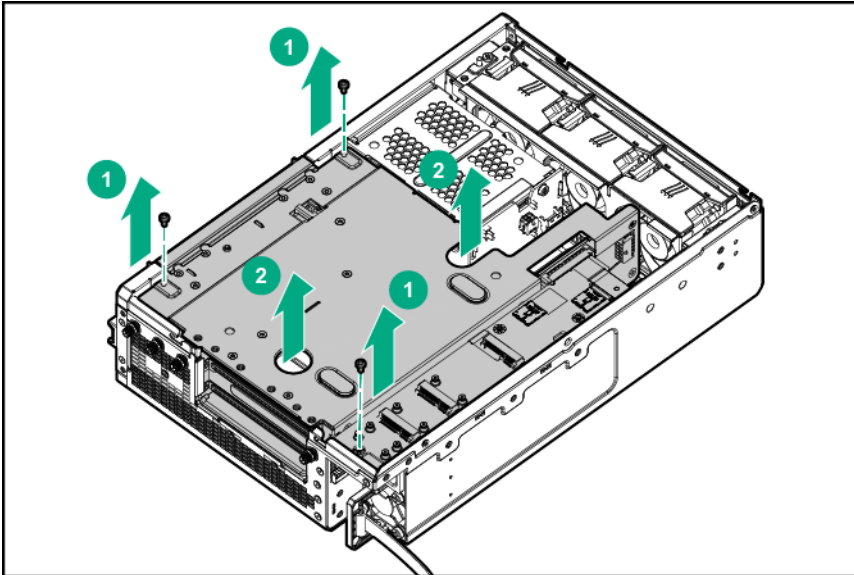

6. Disconnect the power cable.

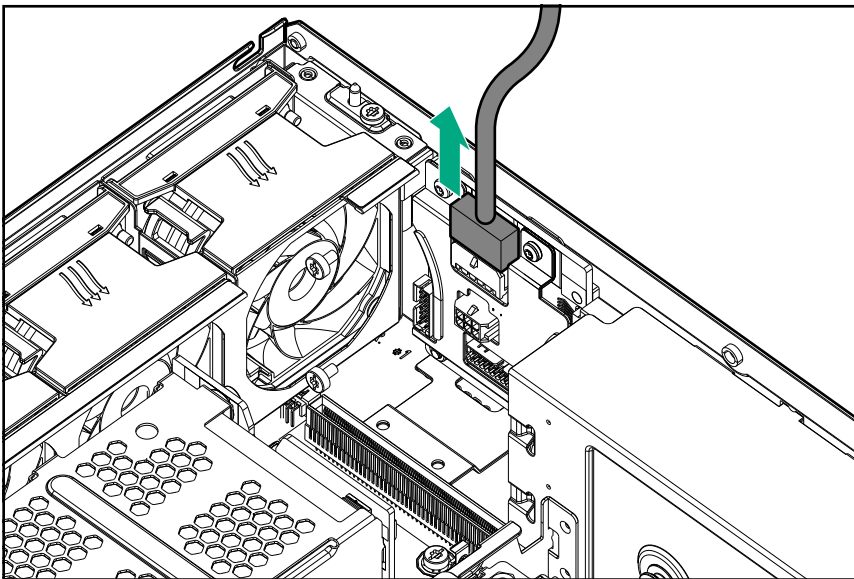

7. Disconnect the hard drive backplane cable and any other cables that connect to the PCIe cards.
8. Align the PCIe card to the PCIe slot on the side of the system, and then slide it in until it clicks in place.

Install the PXI/PXIe card

About this task

The system supports optional PXI cards.

NOTE:

The PXI/PXIe card is not hot-pluggable. The system must be powered down to install this card.

Procedure

1. **Power down the system.**
2. Remove the PXI/PXIe blank screws, and then remove the blank.

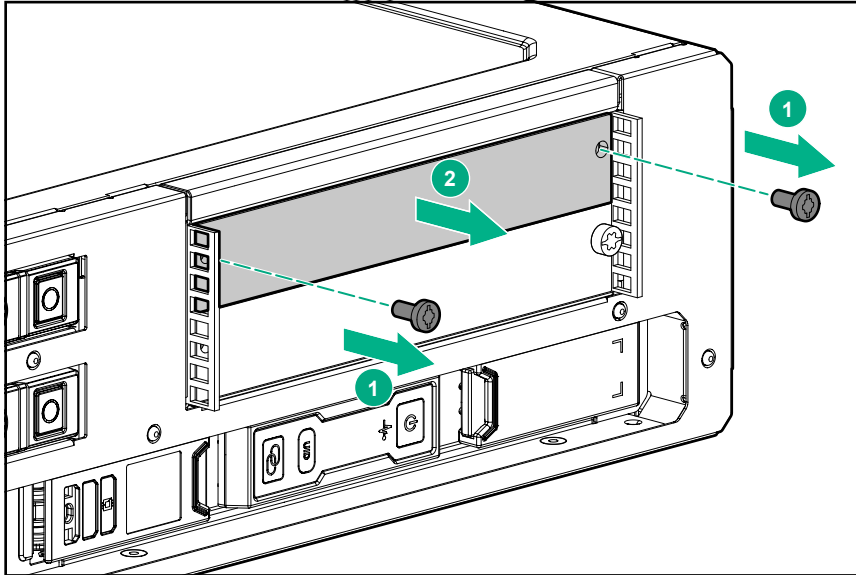

3. Align the PXI/PXIe card to the PXI/PXIe slot in the front panel.
4. Bend the tab and slide the PXI/PXIe card in until it clicks in place.
5. Install the PXI/PXIe card slot screws.

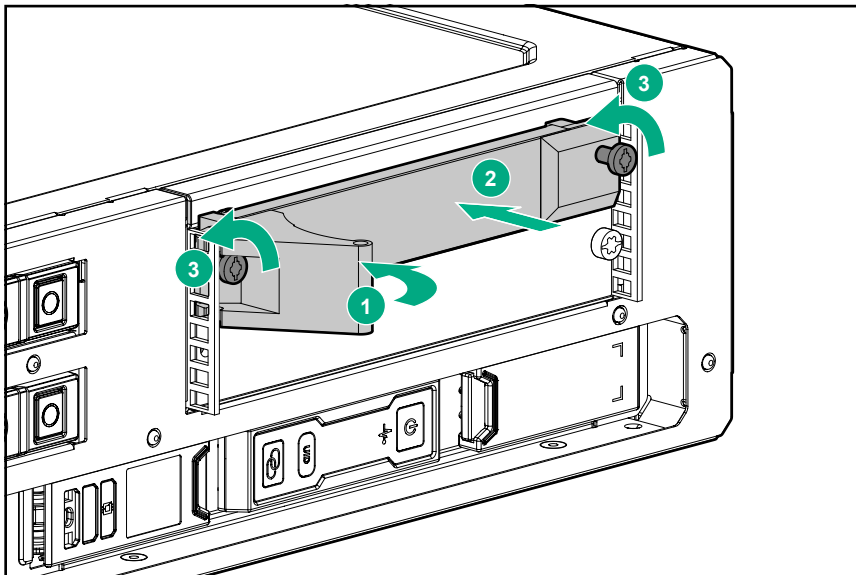

Installing the mini-PCIe module options

You can install the following mini-PCIe modules on the mini-PCIe adapter board:

- Up to two half-length mini-PCIe modules
- Up to two full-length mini-PCIe modules

Install a half-length mini-PCIe module option

About this task

You will need a half-length mini-PCIe module adapter provided with the WiFi option kit to install this option.

Procedure

1. Install the adapter using the two holes of the half-length mini-PCIe module.

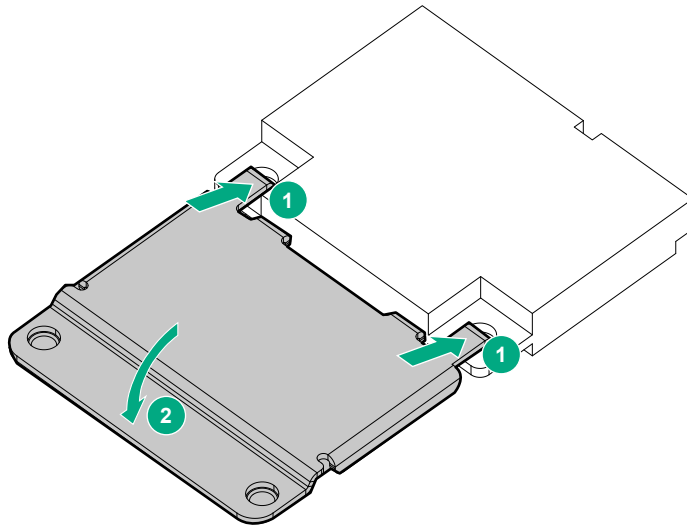

2. Insert the mini-PCIe module connector into the slot.
3. Using a Phillips screwdriver, insert and tighten the two screws to secure the mini-PCIe module to the board.

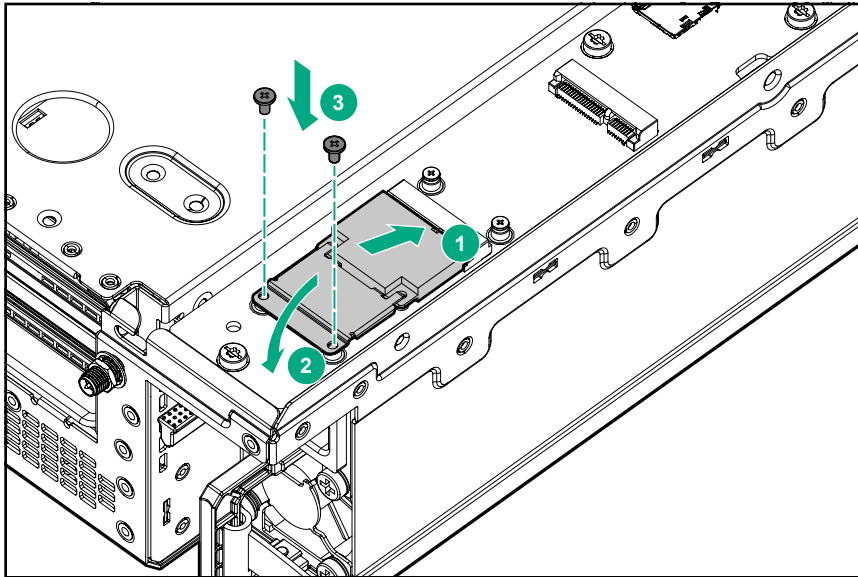

Installing a full-length mini-PCIe module

Procedure

1. Align the full-length mini-PCIe module with the full-length slot on the mini-PCIe adapter board.
2. Insert the mini-PCIe module connector into the slot.
3. Using a Phillips screwdriver, insert and tighten the two screws to secure the mini-PCIe module to the board.

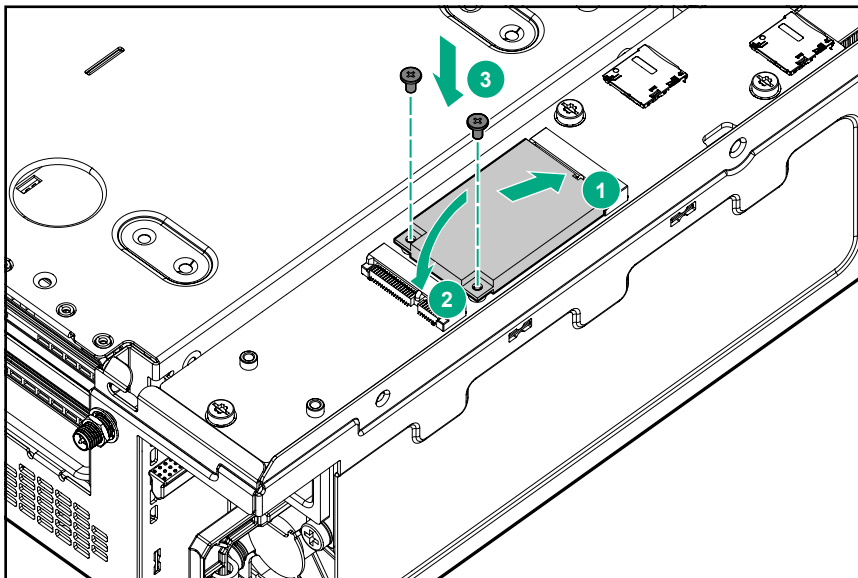

Configuration

Accessing the System Utilities menu

About this task

To complete these steps, you need the HPE USB-to-serial cable (HPE part number 871947-B21).

Table 1: Settings for connecting USB cable to serial port

Specifications	Value
Baud rate	115200
Data bits	8
Parity	None
Stop bit	1 (8 N1)

Procedure

1. Power down the cartridge.
2. Connect the USB-to-serial cable to the system. The USB end is connected to a system USB port.
3. Attach the serial end of the cable to a serial port using a null modem cable. The other serial port may be another USB-to-serial adapter on a different machine.
4. Power on the cartridge. The serial console output screen displays.

```
(C) Copyright 1982 - 2016 Hewlett Packard Enterprise Development LP
HP ProLiant m710x Server Cartridge
BIOS Version: H07 v1.10 (08/05/2016)
Serial Number:

System Memory: 16 GB
1 Processor(s) detected, 4 total cores enabled, Hyperthreading is enabled
Proc 1: Intel(R) Xeon(R) CPU E3-1585 v5 @ 3.50GHz

HPE Power Profile Mode: Balanced Power and Performance
Power Regulator Mode: Dynamic Power Savings
Boot Mode: UEFI

For access via BIOS Serial Console:
Press 'ESC+9' for System Utilities
Press 'ESC+0' for Intelligent Provisioning
Press 'ESC+!' for One-Time Boot Menu
Press 'ESC+@' for Network Boot

Starting drivers. Please wait, this may take a few moments...

█
```

5. Press the **ESC + 9** keys. The System Utilities menu displays.

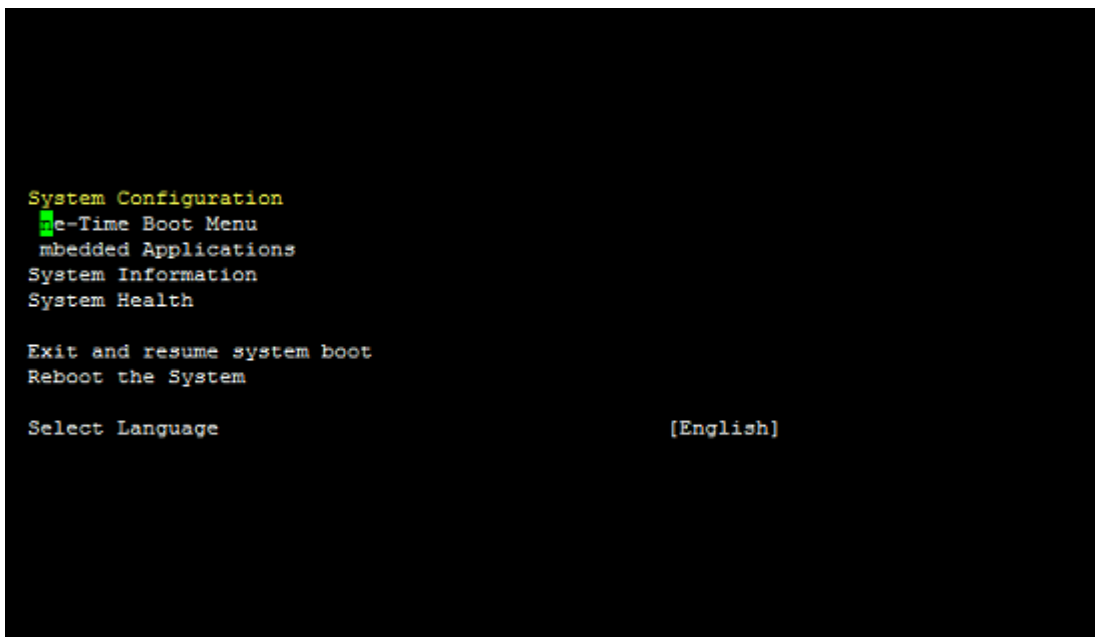

Viewing or updating the DHCP address using the serial console cable

Procedure

1. **Access the System Utilities menu.**
2. Navigate through the menu options **System Configuration > iLO 4 Configuration Utility > Network > DNS/DHCP**, and press **Enter**. The **Network Autoconfiguration** screen displays.
3. View or update the DHCP settings.
4. To save any changes, press the **F10** key.
5. After saving all settings, iLO prompts for a reset in order for any new settings to be used. Reset the system.

Finding the IP address through DHCP

Procedure

1. **Access the System Utilities menu.**
2. Navigate through the menu options **System Configuration > iLO 4 Configuration Utility > Network Options**.
3. The Network Options screen displays the IP address.

```
iLO 4 Configuration Utility

Network Options

MAC Address                [14:02:EC:00:BA:68]
Network Interface Adapter  [ON]
Transceiver Speed Autoselect [ON]

DHCP Enable                [OFF]
DNS Name                   [ILOCN66310D4W]

IP Address                 [172.27.10.100]
Subnet Mask                [255.255.0.0]
Gateway IP Address        [0.0.0.0]
```

Setting the static IP address using the serial console cable

Procedure

1. **Access the System Utilities menu.**
2. Navigate through the menu options **System Configuration > iLO 4 Configuration Utility > Network Options**. The Network Options screen displays.
3. Change **DHCP Enable** to **OFF**.
4. Configure the **IP Address**, **Subnet Mask**, and **Gateway Address** as required. The following image is an example of a completed **Network Options** screen.

```
iLO 4 Configuration Utility
Network Options

MAC Address                [14:02:EC:00:BA:68]
Network Interface Adapter  [ON]
Transceiver Speed Autoselect [ON]

DHCP Enable                [OFF]
DNS Name                   [ILOCN66310D4W]

IP Address                 [172.27.10.100]
Subnet Mask                [255.255.0.0]
Gateway IP Address        [0.0.0.0]
```

5. Once completed, press **ESC** to back out of the menus. Save the settings when prompted.
6. After saving all settings, iLO prompts for a reset in order for the new settings to be used. Reset the system.

Software and configuration utilities

Product QuickSpecs

For more information about product features, specifications, options, configurations, and compatibility, see the product QuickSpecs on the [Hewlett Packard Enterprise website](#).

Supported operating systems and drivers matrix

To validate the minimum supported Operating System for a system platform, go to the Hewlett Packard Enterprise website:

<http://www.hpe.com/info/ossupport>

To download the latest device drivers, go to the Hewlett Packard Enterprise Support Center website:

<http://www.hpe.com/support/hpesc>

HPE iLO

iLO is a remote server management processor embedded on the system boards of HPE ProLiant and Synergy servers. iLO enables the monitoring and controlling of servers from remote locations. HPE iLO management is a powerful tool that provides multiple ways to configure, update, monitor, and repair servers remotely. iLO (Standard) comes preconfigured on HPE servers **without an additional cost or license**.

Features that enhance server administrator productivity are licensed. For more information, see the iLO documentation on the [Hewlett Packard Enterprise website](#).

Active Health System

The HPE Active Health System provides the following features:

- Combined diagnostics tools/scanners
- Always on, continuous monitoring for increased stability and shorter downtimes
- Rich configuration history
- Health and service alerts
- Easy export and upload to Service and Support

The Active Health System monitors and records changes in the server hardware and system configuration. The Active Health System assists in diagnosing problems and delivering rapid resolution if server failures occur.

The Active Health System collects the following types of data:

- Server model
- Serial number
- Processor model and speed
- Storage capacity and speed
- Memory capacity and speed
- Firmware/BIOS

Active Health System does not collect information about Active Health System users' operations, finances, customers, employees, partners, or data center, such as IP addresses, host names, user names, and passwords. Active Health System does not parse or change operating system data from third-party error event log activities, such as content created or passed through by the operating system.

The data that is collected is managed according to the Hewlett Packard Enterprise Data Privacy policy. For more information, see the [Hewlett Packard Enterprise website](#).

The Active Health System, in conjunction with the system monitoring provided by Agentless Management or SNMP Pass-thru, provides continuous monitoring of hardware and configuration changes, system status, and service alerts for various server components.

The Agentless Management Service is available in the SPP, which can be downloaded from the [Hewlett Packard Enterprise website](#). The Active Health System log can be downloaded manually from iLO 4 or HPE Intelligent Provisioning and sent to Hewlett Packard Enterprise.

For more information, see the following documents:

- *iLO User Guide* on the [Hewlett Packard Enterprise website](#)
- *Intelligent Provisioning User Guide* on the [Hewlett Packard Enterprise website](#)

Active Health System data collection

The Active Health System does not collect information about your operations, finances, customers, employees, or partners.

Examples of data that is collected:

- Server model and serial number
- Processor model and speed
- Storage capacity and speed
- Memory capacity and speed
- Firmware/BIOS and driver versions and settings

The Active Health System does not parse or change operating system data from third-party error event log activities (for example, content created or passed through the operating system).

Active Health System log

The data collected by the Active Health System is stored in the Active Health System Log. The data is logged securely, isolated from the operating system, and separate from customer data.

When the Active Health System Log is full, new data overwrites the oldest data in the log.

It takes less than 5 minutes to download the Active Health System Log and send it to a Hewlett Packard Enterprise support professional to help you resolve an issue.

When you download and send Active Health System data to Hewlett Packard Enterprise, you agree to have Hewlett Packard Enterprise use the data for analysis, technical resolution, and quality improvements. The data that is collected is managed according to the privacy statement, available on the [Hewlett Packard Enterprise website](#).

iLO RESTful API support

HPE iLO 4 firmware version 2.00 and later includes the iLO RESTful API. The iLO RESTful API is a management interface that server management tools can use to perform configuration, inventory, and monitoring of the ProLiant server via iLO. The iLO RESTful API uses basic HTTPS operations (GET, PUT, POST, DELETE, and PATCH) to submit or return JSON-formatted data with iLO web server.

HPE iLO 4 2.30 and later is Redfish 1.0-conformant while remaining backward compatible with the existing iLO RESTful API.

HPE iLO 4 supports the iLO RESTful API with ProLiant Gen8 and later servers. For more information about the iLO RESTful API, see the [Hewlett Packard Enterprise website](#).

Integrated Management Log

The IML records hundreds of events and stores them in an easy-to-view form. The IML timestamps each event with 1-minute granularity.

You can view recorded events in the IML in several ways, including the following:

- From within HPE SIM
- From within **UEFI System Utilities**
- From within the Embedded UEFI shell
- From within operating system-specific IML viewers:
 - For Windows: IML Viewer
 - For Linux: IML Viewer Application
- From within the iLO web interface
- From within Insight Diagnostics

HPE Edgeline Component Pack

The HPE Edgeline Component Pack is a comprehensive firmware solution tested on the Edgeline System and delivered as a compressed file. The compressed file includes all the component files needed to update an Edgeline System. Users deploy the firmware updates contained in the HPE Edgeline Component Pack using the included Smart Update Manager, or by updating using the firmware update capability of the iLO 4 on each server cartridge. Download the latest pack from the **[Hewlett Packard Enterprise website](#)**.

HP Smart Update Manager

HP SUM is an application included with the HPE Edgeline Component Pack that provides a web-based GUI for installing and updating firmware on many Hewlett Packard Enterprise products, including the Edgeline System. HP SUM has an integrated discovery engine that finds the installed hardware and current versions of firmware in use on nodes you identify. The application installs updates in the correct order and ensures that all dependencies are met before deploying an update, and prevents an installation if there are version-based dependencies that it cannot resolve.

The version of HP SUM included with each HPE Edgeline Component Pack release is designed to be the best solution for installing Edgeline System firmware updates. Always use the included version of HP SUM for Edgeline System updates. For more information, see the *HPE Edgeline Component Pack Update Guide* in the **[Hewlett Packard Enterprise Information Library](#)**.

UEFI System Utilities

The UEFI System Utilities is embedded in the system ROM. The UEFI System Utilities enable you to perform a wide range of configuration activities, including:

- Configuring system devices and installed options
- Enabling and disabling system features
- Displaying system information
- Selecting the primary boot controller
- Configuring memory options
- Selecting a language
- Launching other preboot environments such as the Embedded UEFI Shell and Intelligent Provisioning

For more information, see the UEFI System Utilities user guide for your product on the **[Hewlett Packard Enterprise website](#)**.

To access mobile-ready online help for the UEFI System Utilities and UEFI Shell, scan the QR code at the bottom of the screen. For on-screen help, press the **F1** key.

Using UEFI System Utilities

To use the System Utilities, use the following keys.

Action	Key
Access System Utilities	F9 during server POST
Navigate menus	Up and Down arrows
Select items	Enter
Save selections	F10
Access Help for a highlighted configuration option ¹	F1

¹ Scan the QR code on the screen to access online help for the UEFI System Utilities and UEFI Shell.

Default configuration settings are applied to the server at one of the following times:

- Upon the first system power-up
- After defaults have been restored

Default configuration settings are sufficient for typical server operations; however, you can modify configuration settings as needed. The system prompts you for access to the UEFI System Utilities each time the system is powered up.

Flexible boot control

This feature enables you to do the following:

- Add Boot Options:
 - Browse all FAT16 and FAT32 file systems.
 - To add a new UEFI boot option, select an X64 UEFI application with an .EFI extension. For example, adding an OS boot loader or other UEFI application as a new UEFI boot option.

The new boot option is appended to the boot-order list. When you select a file, you are prompted to enter the boot option description. This description, and any optional data to be passed to an .EFI application, is then displayed in the boot menu.
- Boot to System Utilities

After pre-POST, the boot options screen appears. During this time, you can access the UEFI System Utilities by pressing the **F9** key.
- Choose between supported modes:
 - Legacy BIOS Boot Mode
 - UEFI Boot Mode



IMPORTANT:

If the default boot mode settings are different than the user-defined settings, the system might not boot the OS installation if the defaults are restored. To avoid this issue, use the User Defined Defaults feature in UEFI System Utilities to override the factory default settings.

For more information, see the UEFI System Utilities user guide for your product on the [Hewlett Packard Enterprise Information Library](#).

Restoring and customizing configuration settings

You can reset all configuration settings to the factory default settings, or you can restore and use the system default configuration settings.

You can also configure default settings as necessary, and then save the configuration as the custom default configuration. When the system loads the default settings, it uses the custom default settings instead of the factory defaults.

Secure Boot configuration

Secure Boot is integrated in the UEFI specification on which the Hewlett Packard Enterprise implementation of UEFI is based. Secure Boot is implemented in the BIOS and does not require special hardware. Secure Boot ensures that each component launched during the boot process is digitally signed. Secure Boot also ensures that the signature is validated against a set of trusted certificates embedded in the UEFI BIOS. Secure Boot validates the software identity of the following components in the boot process:

- UEFI drivers loaded from PCIe cards
- UEFI drivers loaded from mass storage devices
- Preboot UEFI shell applications
- OS UEFI boot loaders

When enabled, only firmware components and operating systems with boot loaders that have an appropriate digital signature can execute during the boot process. Only operating systems that support Secure Boot and have an EFI boot loader signed with one of the authorized keys can boot. For more information about supported operating systems, see the UEFI System Utilities and Shell release notes for your system on the [Hewlett Packard Enterprise website](#).

A physically present user can customize the certificates embedded in the UEFI BIOS by adding or removing their own certificates.

When Secure Boot is enabled, the System Maintenance Switch does not restore all manufacturing defaults when set to the ON position. For security reasons, the following are not restored to defaults when the System Maintenance Switch is in the ON position:

- Secure Boot is not disabled and remains enabled.
- The Boot Mode remains in UEFI Boot Mode even if the default boot mode is Legacy Boot Mode.
- The Secure Boot Database is not restored to its default state.
- iSCSI Software Initiator configuration settings are not restored to defaults.

Embedded UEFI shell

The system BIOS in all ProLiant Gen9 servers includes an Embedded UEFI Shell in the ROM. The UEFI Shell environment provides an API, a command-line prompt, and a set of CLIs that allow scripting, file manipulation, and system information. These features enhance the capabilities of the UEFI System Utilities.

For more information, see the following documents:

- *UEFI Shell User Guide for HPE ProLiant Gen9 Servers* on the [Hewlett Packard Enterprise website](#)
- *UEFI Shell Specification* on the [UEFI website](#)

Embedded Diagnostics option

The system BIOS in all ProLiant Gen9 servers includes an Embedded Diagnostics option in the ROM. The Embedded Diagnostics option can run comprehensive diagnostics of the server hardware, including processors, memory, drives, and other server components.

For more information on the Embedded Diagnostics option, see the UEFI System Utilities user guide for your system on the [Hewlett Packard Enterprise website](#).

iLO RESTful API support for UEFI

The ProLiant Gen9 servers include support for a UEFI-compliant System BIOS, along with UEFI System Utilities and Embedded UEFI Shell preboot environments. ProLiant Gen9 servers also support configuring the UEFI BIOS settings using the iLO RESTful API, a management interface that server management tools can use to perform configuration, inventory, and monitoring of a ProLiant server. The iLO RESTful API uses basic HTTPS operations (GET, PUT, POST, DELETE, and PATCH) to submit or return JSON-formatted data with iLO web server.

For more information about the iLO RESTful API and the RESTful Interface Tool, see the [Hewlett Packard Enterprise website](#).

Re-entering the server serial number and product ID

About this task

After you replace the system board, you must re-enter the system serial number and the product ID:

Procedure

1. During the system startup sequence, press the **F9** key to access UEFI System Utilities.
2. Select **System Configuration > BIOS/Platform Configuration (RBSU) > Advanced Options > Advanced System ROM Options > Serial Number**, and then press the **Enter** key.
3. Enter the serial number and press the **Enter** key.

The following message appears:

```
The serial number should only be modified by qualified service personnel.  
This value should always match the serial number located on the chassis.
```

4. To clear the warning, press the **Enter** key.
5. Enter the serial number and press the **Enter** key.
6. Select **Product ID**.

The following warning appears:

```
Warning: The Product ID should ONLY be modified by qualified service  
personnel. This value should always match the Product ID located on the  
chassis.
```

7. Enter the product ID and press the **Enter** key.
8. To confirm exiting System Utilities, press the **F10** key.

The system automatically reboots.

Troubleshooting

HPE Edgeline Troubleshooting Guide

The *HPE Edgeline System Troubleshooting Guide* provides procedures for resolving common problems and comprehensive courses of action for fault isolation and identification, issue resolution, and software maintenance on the Edgeline System. The document is available in the **Hewlett Packard Enterprise Information Library**.

Battery

Battery specifications

Feature	Specification
Type	Maintenance-free, sealed, CR2032 lithium manganese dioxide button battery
Voltage	3.0 V

Replace the system battery

Procedure

1. Locate the battery on the system board:
 - **PCIe configuration system board**
 - **PXle configuration system board**
2. Slightly push the metal tab, and then use the small flat-nose pliers to remove the system battery from its socket.

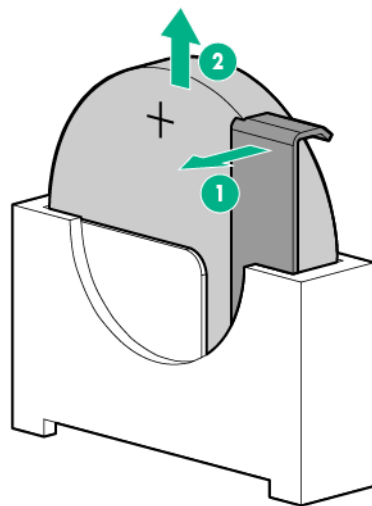

3. Slightly push the metal tab, then install the system battery in the socket.

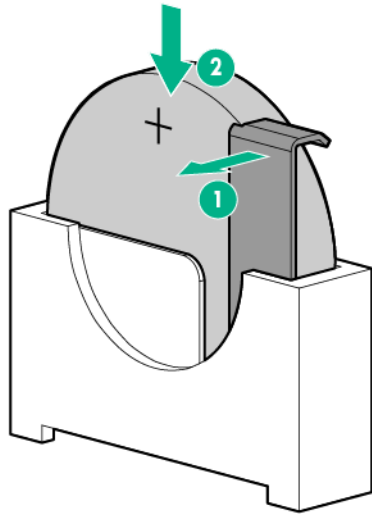

For more information about battery replacement or proper disposal, contact an authorized reseller or an authorized service provider.

Warranty and regulatory information

Warranty information

[HPE ProLiant and x86 Servers and Options](#)

[HPE Enterprise Servers](#)

[HPE Storage Products](#)

[HPE Networking Products](#)

Regulatory information

Safety and regulatory compliance

For important safety, environmental, and regulatory information, see *Safety and Compliance Information for Server, Storage, Power, Networking, and Rack Products*, available at the Hewlett Packard Enterprise website (<http://www.hpe.com/support/Safety-Compliance-EnterpriseProducts>).

Belarus Kazakhstan Russia marking



Manufacturer and Local Representative Information

Manufacturer information:

- Hewlett Packard Enterprise Company, 3000 Hanover Street, Palo Alto, CA 94304 U.S.

Local representative information Russian:

- Russia:

ООО «Хьюлетт Паккард Энтерпрайз», Российская Федерация, 125171, г. Москва, Ленинградское шоссе, 16А, стр.3, Телефон/факс: +7 495 797 35 00

- Belarus:

ИООО «Хьюлетт-Паккард Бел», Республика Беларусь, 220030, г. Минск, ул. Интернациональная, 36-1, Телефон/факс: +375 17 392 28 20

- Kazakhstan:

ТОО «Хьюлетт-Паккард (К)», Республика Казахстан, 050040, г. Алматы, Бостандыкский район, проспект Аль-Фараби, 77/7, Телефон/факс: + 7 727 355 35 52

Local representative information Kazakh:

- Russia:

ЖШС "Хьюлетт Паккард Энтерпрайз", Ресей Федерациясы, 125171, Мәскеу, Ленинград тас жолы, 16А блок 3, Телефон/факс: +7 495 797 35 00

- Belarus:

«HEWLETT-PACKARD Bel» ЖШС, Беларусь Республикасы, 220030, Минск қ.,
Интернациональная көшесі, 36/1, Телефон/факс: +375 17 392 28 20

- Kazakhstan:

ЖШС «Хьюлетт-Паккард (К)», Қазақстан Республикасы, 050040, Алматы қ.,
Бостандық ауданы, Әл-Фараби даңғылы, 77/7, Телефон/факс: +7 727 355 35 52

Manufacturing date:

The manufacturing date is defined by the serial number.

CCSYWWZZZZ (serial number format for this product)

Valid date formats include:

- YWW, where Y indicates the year counting from within each new decade, with 2000 as the starting point; for example, 238: 2 for 2002 and 38 for the week of September 9. In addition, 2010 is indicated by 0, 2011 by 1, 2012 by 2, 2013 by 3, and so forth.
- YYWW, where YY indicates the year, using a base year of 2000; for example, 0238: 02 for 2002 and 38 for the week of September 9.

Turkey RoHS material content declaration

Türkiye Cumhuriyeti: EEE Yönetmeliğine Uygundur

Ukraine RoHS material content declaration

Обладнання відповідає вимогам Технічного регламенту щодо обмеження використання деяких небезпечних речовин в електричному та електронному обладнанні, затвердженого постановою Кабінету Міністрів України від 3 грудня 2008 № 1057

Electrostatic discharge

Preventing electrostatic discharge

About this task

To prevent damaging the system, be aware of the precautions you must follow when setting up the system or handling parts. A discharge of static electricity from a finger or other conductor may damage system boards or other static-sensitive devices. This type of damage may reduce the life expectancy of the device.

Procedure

- Avoid hand contact by transporting and storing products in static-safe containers.
- Keep electrostatic-sensitive parts in their containers until they arrive at static-free workstations.
- Place parts on a grounded surface before removing them from their containers.
- Avoid touching pins, leads, or circuitry.
- Always be properly grounded when touching a static-sensitive component or assembly.

Grounding methods to prevent electrostatic discharge

Several methods are used for grounding. Use one or more of the following methods when handling or installing electrostatic-sensitive parts:

- Use a wrist strap connected by a ground cord to a grounded workstation or computer chassis. Wrist straps are flexible straps with a minimum of 1 megohm \pm 10 percent resistance in the ground cords. To provide proper ground, wear the strap snug against the skin.
- Use heel straps, toe straps, or boot straps at standing workstations. Wear the straps on both feet when standing on conductive floors or dissipating floor mats.
- Use conductive field service tools.
- Use a portable field service kit with a folding static-dissipating work mat.

If you do not have any of the suggested equipment for proper grounding, have an authorized reseller install the part.

For more information on static electricity or assistance with product installation, contact the **Hewlett Packard Enterprise Support Center**.

Specifications

Product QuickSpecs

For more information about product features, specifications, options, configurations, and compatibility, see the product QuickSpecs on the [Hewlett Packard Enterprise website](#).

Environmental specifications

Table 2: Standard specifications

Specification	Value
Temperature range¹	—
Operating	10°C to 35°C (50°F to 95°F)
Nonoperating	-30°C to 60°C (-22°F to 140°F)
Relative humidity (noncondensing)	—
Operating	8% to 90% at 28°C (82.4°F) maximum wet bulb temperature
Non-Operating	5% to 95% at 38.7°C (101.7°F) maximum wet bulb temperature

¹ All temperature ratings shown are for sea level. An altitude derating of 1.0°C per 304.8 m (1.8°F per 1,000 ft) to 3,048 m (10,000 ft) is applicable. No direct sunlight allowed. Maximum rate of change is 20°C per hour (36°F per hour).

Table 3: ASHRAE Class A3 specifications

Specification	Value
Temperature range¹	—
Operating	5°C to 40°C (41°F to 104°F)
Nonoperating	-30°C to 60°C (-22°F to 140°F)
Relative humidity (noncondensing)	—
Operating	8% to 90% at 28°C (82.4°F) maximum wet bulb temperature
Non-Operating	5% to 95% at 38.7°C (101.7°F) maximum wet bulb temperature

¹ All temperature ratings shown are for sea level. Good for 40°C operation up to 1,828 m (6,000 ft) with no altitude de-rating. No restriction on product configurations. Abnormal configurations, allowed for up to 96 hours at one time, no more than 15 days maximum per year. Operation above 40°C (104°F) up to 55°C (131°F), no altitude de-rating, 1,828 m (6,000 ft) limit. Some components could be outside the thermal maximum limits. System must be kept running, processor throttling is allowed. Abnormal conditions allow for operation down to -5°C (23°F).

Table 4: ASHRAE Class A4 specifications

Specification	Value
Temperature range¹	—
Operating	5°C to 45°C (41°F to 113°F)
Nonoperating	-30°C to 60°C (-22°F to 140°F)
Relative humidity (noncondensing)	—
Operating	8% to 90% at 28°C (82.4°F) maximum wet bulb temperature
Non-Operating	5% to 95% at 38.7°C (101.7°F) maximum wet bulb temperature

¹ All temperature ratings shown are for sea level. An altitude derating of 1.0°C per 125 m (1.8°F per 410 ft) to 900 m (2,953 ft) is applicable. No direct sunlight allowed. Maximum rate of change is 20°C per hour (36°F per hour). No restrictions on product configurations except for rotating hard drives. PCI cards must be rated for continuous operation with 60°C cooling air. Not rated for operation over 3,030 m (10,000 ft).

Table 5: Extended Edgeline specifications

Specification	Value
Temperature range¹	—
Operating	0°C to 55°C (32°F to 131°F)
Nonoperating	-30°C to 60°C (-22°F to 140°F)
Relative humidity (noncondensing)	—
Operating	8% to 90% at 28°C (82.4°F) maximum wet bulb temperature
Non-Operating	5% to 95% at 38.7°C (101.7°F) maximum wet bulb temperature

¹ All temperature ratings shown are for sea level. An altitude derating of 1.0°C per 304.8 m (1.8°F per 1,000 ft) to 3,048 m (10,000 ft) is applicable. No direct sunlight allowed. Maximum rate of change is 20°C per hour (36°F per hour).

Environmental specifications-system components support matrix

Environmental specification	Support status						
	Base system	Fans	SFF drives	SATA M.2 drives	NVME M.2 drives	PCIe I/O cards	PXle I/O cards
Standard Operating Support	Yes	Yes (with redundancy)	Yes	Yes	Yes	Yes	Yes (up to 38 W) ¹
Extended Ambient 40°C Operating Support (ASHRAE Class A3 Compliant)	Yes	Yes (with redundancy) ²	Yes	Yes	Yes	Yes	Yes (up to 38 W) ¹
Extended Ambient 45°C Operating Support (ASHRAE Class A4 Compliant)	Yes	Yes (with redundancy) ²	Yes (less than 8 W)	Yes	Yes ³	Yes	Yes (up to 38 W) ¹
Extended Edgeline 0°C to 55°C Operating Support	Yes ⁴	Yes (with redundancy) ²	No	Yes	No	Yes ⁵	Yes (up to 38 W) ¹

¹ Maximum altitude is 2,000 m (800 mbar) (at 25 °C ambient temperature)

² Upon fan failure, the servers in the system might have reduced performance.

³ M.2 drive might exceed its spec by 2°C to 3°C and have slight throttling.

⁴ Near 55°C inlet ambient temperature, when the CPU is stressed at 100%, the HPE m510 -16c server might have reduced performance.

⁵ The PCI card must have inlet spec rated at 65°C or higher, and an air speed of 375 ft/min.

Mechanical specifications

Specification	Value
Length	87.4 mm (3.44 in)
Width	338 mm (13.30 in)
Depth	234 mm (9.20 in)
Weight	7.5 kg (16.53 lb)

Power supply specifications

HPE 500W Flex Slot Platinum Hot Plug Power Supply

Input voltage range (V rms)	100-240							
Frequency range (Nominal) (Hz)	50-60							
Nominal input voltage (V rms)	100	120	127	200	208	220	230	240
Maximum rated output wattage rating (Watts)	500	500	500	500	500	500	500	500
Nominal input current (A rms)	5.6	4.6	4.3	2.7	2.6	2.5	2.4	2.3
Maximum rated input wattage rating (Watts)	558	550	543	539	538	538	537	537
Maximum rated VA (Volt-Amp)	564	556	549	544	544	543	542	542
Efficiency (%)	89.6	90.9	92.1	92.8	92.9	93.0	93.1	93.1
Power factor	0.99	0.99	0.99	0.99	0.99	0.99	0.99	0.99
Leakage current (mA)	0.32	0.38	0.40	0.63	0.65	0.69	0.72	0.75
Maximum inrush current (A peak)	30	30	30	30	30	30	30	30
Maximum inrush current duration (ms)	10	10	10	10	10	10	10	10
Maximum British Thermal Unit rating (BTU-Hr)	1904	1877	1853	1839	1837	1834	1832	1832

HPE 800W Flex -48VDC Hot Plug Power Supply

Input voltage range (V DC)	-40 to -72		
Frequency range (Nominal) (Hz)	DC		
Nominal input voltage (V DC)	-40	-48	-72
Maximum rated output wattage rating (Watts)	800	800	800
Nominal input current (A DC)	22.0	18.1	11.9
Maximum rated input wattage rating (Watts)	882	871	858
Maximum rated VA (Volt-Amp)	882	871	858
Efficiency (%)	90.7	91.9	93.2
Power factor	1.0	1.0	1.0
Leakage current (mA)	0.0	0.0	0.0
Maximum inrush current (A peak)	30	30	30
Maximum inrush current duration (ms)	10	10	10
Maximum British Thermal Unit rating (BTU-Hr)	3008	2971	2929

PXI/PXIe specifications

NOTE: Specifications are subject to change without notice.

Electrical load regulation specifications

Voltage (V)	Load regulation (%)
+3.3	<5
+12	<5
+5	<5
-12	<5

Chassis cooling specifications

Specification	Value
Module cooling system	Forced air circulation (positive pressurization) through three fans with High/Auto speed selector. Launch Recipe supports this.
Airflow	From front to rear

Pollution specifications

Specifications	Value
Pollution degree	2

For indoor use only in a climate-controlled environment.

Shock and vibration specifications

Specification	Value
Operational shock	30 g peak, half-sine, 11 ms pulse
Random vibration	5 Hz to 500 Hz, 0.3 g rms

Acoustic emission specifications

Acoustic noise

Acoustic noise specifications for the following base configurations are available.

Table 6: Base configuration 1 (m510)

Component	Quantity	Specification
Cartridge	4	m510
DIMMs/cartridge	4	Any

Table Continued

Component	Quantity	Specification
SATA M.2/cartridge	1	64 GB
NVME M.2/cartridge	0	NA
PXI	4	PXI 6341
PSU	2	800 W AC

Table 7: Base configuration 2 (m710x)

Component	Quantity	Specification
Cartridge	4	m710x
DIMMs/cartridge	4	Any
SATA M.2/cartridge	1	64 GB
NVME M.2/cartridge	0	NA
PXI	4	PXI 6341
PSU	2	800 W AC

The LWAd and LpAm when the system is operating in a 23°C ambient environment are provided in the following tables. Noise emissions were measured in accordance with ISO 7779 (ECMA 74) and declared in accordance with ISO 9296 (ECMA 109).

Table 8: Acoustic noise when system is idle

system configuration	LWAd (B)	LpAm (dBA)
Base 1	8	64.6
Base 2	8	64.6

Table 9: Acoustic noise when system is operating

system configuration	LWAd (B)	LpAm (dBA)
Base 1	8	64.6
Bae 2	8	64.6

NOTE:

If used in a manner not described in this document, the protection provided by the system can be impaired.

HPE EMC compliance testing

Emissions classification	FCC rating	Class A
EMC	Normative standards	<ul style="list-style-type: none"> • CISPR 22 • EN55022 • EN55024 • FCC CFR 47 • Pt 15 • ICES-003 • CNS13438 • K22 • K24 • EN 61000-3-2 • EN 61000-3-3 • EN 60950-1 • IEC 60950-1

NOTE:

Product conformance to cited product specifications is based on sample (type) testing, evaluation, or assessment. This product or family of products is eligible to bear the appropriate compliance logos and statements.

System synchronization clock specifications

10 MHz system reference clock: PXI_CLK10

Specification	Value
Maximum slot-to-slot skew	1 ns
Accuracy	±25 ppm max (guaranteed over the operating temperature range)
Maximum jitter	5 ps RMS phase jitter (10 Hz to 1 MHz range)
Duty factor	45% to 55%
Unloaded signal swing	3.3 V ±0.3 V

NOTE:

For other specifications, see 'PXI-1 Hardware Specification' at the PXI Systems Alliance website (<http://www.pxisa.org/userfiles/files/Specifications/PXIHWSPEC22.pdf>).

100 MHz system reference clock: PXIe_CLK100 and PXIe_SYNC100

Specification	Value
Maximum slot-to-slot skew	200 ps
Accuracy	±25 ppm max (guaranteed over the operating temperature range)

Table Continued

Specification	Value
Maximum jitter	5 ps RMS phase jitter (10 Hz to 12 kHz range); 5 ps RMS phase jitter (12 kHz to 20 MHz range)
Duty factor for PXIe_CLK100	45% to 55%
Absolute single-ended voltage swing (when each line in the differential pair has 50 W termination to 1.30 V or Thévenin equivalent)	400 mV to 1,000 mV

NOTE:

For other specifications, see 'PXI-5 PXI Express Hardware Specification' at the PXI Systems Alliance website (http://www.pxisa.org/userfiles/files/Specifications/PXIEXPRESS_HW_SPEC_R1.PDF).

External 10 MHz reference out (SMA on front panel of chassis)

Specification	Value
Accuracy	±25 ppm max (guaranteed over the operating temperature range)
Maximum jitter	5 ps RMS phase jitter (10 Hz to 1 MHz range)
Output amplitude	1 VPP ±20% square wave into 50 Ω 2 VPP unloaded
Output impedance	50 Ω ±5 Ω

External clock source

Specification	Value
Frequency	10 MHz ±100 PPM
Input amplitude	—
Front panel BNC	200 mVPP to 5 VPP square-wave or sine-wave
Front panel SMA input impedance	50 Ω ± 5 Ω

Support and other resources

Websites

- [Hewlett Packard Enterprise Information Library](#)
- [Hewlett Packard Enterprise Support Center](#)
- [Contact Hewlett Packard Enterprise Worldwide](#)
- [Subscription Service/Support Alerts](#)
- [Software Depot](#)
- [Customer Self Repair](#)
- [Insight Remote Support](#)
- [Serviceguard Solutions for HP-UX](#)
- [Single Point of Connectivity Knowledge \(SPOCK\) Storage compatibility matrix](#)
- [Storage white papers and analyst reports](#)

Accessing Hewlett Packard Enterprise Support

- For live assistance, go to the Contact Hewlett Packard Enterprise Worldwide website:
<http://www.hpe.com/assistance>
- To access documentation and support services, go to the Hewlett Packard Enterprise Support Center website:
<http://www.hpe.com/support/hpesc>

Information to collect

- Technical support registration number (if applicable)
- Product name, model or version, and serial number
- Operating system name and version
- Firmware version
- Error messages
- Product-specific reports and logs
- Add-on products or components
- Third-party products or components

Information to collect

- Technical support registration number (if applicable)
- Product name, model or version, and serial number
- Operating system name and version
- Firmware version
- Error messages
- Product-specific reports and logs
- Add-on products or components
- Third-party products or components

Accessing updates

- Some software products provide a mechanism for accessing software updates through the product interface. Review your product documentation to identify the recommended software update method.
- To download product updates:

Hewlett Packard Enterprise Support Center

www.hpe.com/support/hpesc

Hewlett Packard Enterprise Support Center: Software downloads

www.hpe.com/support/downloads

Software Depot

www.hpe.com/support/softwaredepot

- To subscribe to eNewsletters and alerts:

www.hpe.com/support/e-updates

- To view and update your entitlements, and to link your contracts and warranties with your profile, go to the Hewlett Packard Enterprise Support Center **More Information on Access to Support Materials** page:

www.hpe.com/support/AccessToSupportMaterials

IMPORTANT:

Access to some updates might require product entitlement when accessed through the Hewlett Packard Enterprise Support Center. You must have an HPE Passport set up with relevant entitlements.

Customer self repair

Hewlett Packard Enterprise customer self repair (CSR) programs allow you to repair your product. If a CSR part needs to be replaced, it will be shipped directly to you so that you can install it at your convenience. Some parts do not qualify for CSR. Your Hewlett Packard Enterprise authorized service provider will determine whether a repair can be accomplished by CSR.

For more information about CSR, contact your local service provider or go to the CSR website:

<http://www.hpe.com/support/selfrepair>

Remote support

Remote support is available with supported devices as part of your warranty or contractual support agreement. It provides intelligent event diagnosis, and automatic, secure submission of hardware event notifications to Hewlett Packard Enterprise, which will initiate a fast and accurate resolution based on your product's service level. Hewlett Packard Enterprise strongly recommends that you register your device for remote support.

If your product includes additional remote support details, use search to locate that information.

Remote support and Proactive Care information

HPE Get Connected

www.hpe.com/services/getconnected

HPE Proactive Care services

www.hpe.com/services/proactivecare

HPE Proactive Care service: Supported products list

www.hpe.com/services/proactivecaresupportedproducts

HPE Proactive Care advanced service: Supported products list

www.hpe.com/services/proactivecareadvancedsupportedproducts

Proactive Care customer information

Proactive Care central

www.hpe.com/services/proactivecarecentral

Proactive Care service activation

www.hpe.com/services/proactivecarecentralgetstarted

Acronyms and abbreviations

CM

chassis management

iLO

integrated Lights-Out

LTE

long-term evolution

PCI

peripheral component interconnect

PCIe

peripheral component interconnect express

PXE

preboot execution environment

PXI

PCI eXtensions for instrumentation

PXIe

PCI eXtensions for instrumentation express

QSFP+

enhanced quad small form-factor pluggable

SFP+

enhanced small form-factor pluggable

UEFI

Unified Extensible Firmware Interface

UID

unit identification

WiFi

wireless fidelity

WLAN

wireless local area network

WWAN

wireless wide area network

Documentation feedback

Hewlett Packard Enterprise is committed to providing documentation that meets your needs. To help us improve the documentation, send any errors, suggestions, or comments to Documentation Feedback (docsfeedback@hpe.com). When submitting your feedback, include the document title, part number, edition, and publication date located on the front cover of the document. For online help content, include the product name, product version, help edition, and publication date located on the legal notices page.