



**Hewlett Packard
Enterprise**

HPE Edgeline EL4000 System User Guide

Abstract

This document is for the person who installs, administers, and troubleshoots servers and storage systems. Hewlett Packard Enterprise assumes you are qualified in the servicing of computer equipment and trained in recognizing hazards in products with hazardous energy levels.

Part Number: 868755-002
Published: May 2017
Edition: 2

Notices

The information contained herein is subject to change without notice. The only warranties for Hewlett Packard Enterprise products and services are set forth in the express warranty statements accompanying such products and services. Nothing herein should be construed as constituting an additional warranty. Hewlett Packard Enterprise shall not be liable for technical or editorial errors or omissions contained herein.

Confidential computer software. Valid license from Hewlett Packard Enterprise required for possession, use, or copying. Consistent with FAR 12.211 and 12.212, Commercial Computer Software, Computer Software Documentation, and Technical Data for Commercial Items are licensed to the U.S. Government under vendor's standard commercial license.

Links to third-party websites take you outside the Hewlett Packard Enterprise website. Hewlett Packard Enterprise has no control over and is not responsible for information outside the Hewlett Packard Enterprise website.

Acknowledgments

Intel[®], Itanium[®], Pentium[®], Intel Inside[®], and the Intel Inside logo are trademarks of Intel Corporation in the United States and other countries.

Microsoft[®] and Windows[®] are either registered trademarks or trademarks of Microsoft Corporation in the United States and/or other countries.

Linux[™] is the registered trademark of Linus Torvalds in the U.S. and other countries.

SD[™] and microSD[™] are trademarks or registered trademarks of SD-3C in the United States, other countries or both.

NVIDIA[™] is a trademark of NVIDIA Corporation in the U.S. and other countries.

Contents

- Component identification..... 6**
 - Base configurations..... 6
 - PCIe configuration..... 6
 - Front panel components..... 6
 - Front panel LEDs and buttons..... 7
 - Rear panel components..... 8
 - System board components (PCIe)..... 8
 - Cartridge slot identification..... 9
 - PXIe configuration..... 9
 - Front panel components..... 9
 - Front panel LEDs and buttons..... 10
 - Rear panel components..... 11
 - Rear panel LEDs and buttons..... 11
 - System board components (PXIe)..... 12
 - Cartridge slot identification..... 12

- Operations..... 14**
 - Install an AC power supply..... 14
 - Install the DC power supply..... 14
 - Install a power supply blank..... 18
 - Power down the system..... 19
 - Power up the system..... 19
 - Mount the system..... 19
 - Remove the access panel..... 20
 - Removing the PCIe access panel..... 20
 - Removing the PXIe access panel..... 20
 - Remove the fixed top cover..... 21
 - Removing the fixed top cover of the PCIe system..... 21
 - Removing the fixed front top cover of the PXIe system..... 21
 - Removing the fixed rear top cover of the PXIe system..... 22
 - Install the fans..... 22
 - Install the cartridge..... 23

- Setup..... 25**
 - Optional services..... 25
 - Optimum environment..... 25
 - Space and airflow requirements..... 25
 - Temperature requirements..... 25
 - Power requirements..... 25
 - Installing hardware options 26
 - Registering the product..... 26

- Hardware options installation..... 27**
 - Installing the short extension rail kit..... 27
 - Installing the full extension rail kit with cable management arm..... 27

Configuration.....	28
Networking in the chassis.....	28
Accessing the System Utilities menu.....	29
Viewing or updating the DHCP address using the serial console cable.....	30
Finding the IP address through DHCP.....	30
Setting the static IP address using the serial console cable.....	31
Software and configuration utilities.....	33
Product QuickSpecs.....	33
Supported operating systems and drivers matrix	33
HPE iLO.....	33
Active Health System.....	33
Active Health System data collection.....	33
Active Health System log.....	34
iLO RESTful API support.....	34
Integrated Management Log.....	34
HPE Insight Cluster Management Utility.....	34
HPE Edgeline Component Pack.....	35
HP Smart Update Manager.....	35
UEFI System Utilities.....	35
Using UEFI System Utilities.....	35
Flexible boot control.....	36
Restoring and customizing configuration settings.....	36
Secure Boot configuration.....	37
Embedded UEFI shell.....	37
Embedded Diagnostics option.....	37
iLO RESTful API support for UEFI.....	38
Re-entering the server serial number and product ID.....	38
Troubleshooting.....	39
HPE Edgeline Troubleshooting Guide.....	39
Battery.....	40
Battery specifications.....	40
Replace the system battery.....	40
Warranty and regulatory information.....	42
Warranty information.....	42
Regulatory information.....	42
Safety and regulatory compliance.....	42
Belarus Kazakhstan Russia marking.....	42
Turkey RoHS material content declaration.....	43
Ukraine RoHS material content declaration.....	43
Electrostatic discharge.....	44
Preventing electrostatic discharge.....	44
Grounding methods to prevent electrostatic discharge.....	44

- Specifications..... 45**
 - Product QuickSpecs..... 45
 - Environmental specifications 45
 - Environmental specifications-system components support matrix.....46
 - Mechanical specifications..... 47
 - Power supply specifications..... 47
 - HPE 800W Flex Slot Platinum Hot Plug Power Supply..... 47
 - HPE 800W Flex -48VDC Hot Plug Power Supply.....48
 - PXI/PXle specifications.....49
 - Electrical load regulation specifications..... 49
 - Chassis cooling specifications..... 49
 - Pollution specifications.....49
 - Shock and vibration specifications.....49
 - Acoustic emission specifications49
 - System synchronization clock specifications..... 50

- Websites..... 52**

- Support and other resources..... 53**
 - Accessing Hewlett Packard Enterprise Support..... 53
 - Information to collect..... 53
 - Accessing updates..... 53
 - Customer self repair..... 53
 - Remote support..... 54

- Acronyms and abbreviations..... 55**

- Documentation feedback..... 57**

Component identification

Base configurations

The HPE Edgeline EL4000 System comes in the following configurations:

- HPE Edgeline EL4000 4x10GbE 2xQSFP+ PassThru System

Supports 1 to 4 full-height, half-length PCIe cards. The core network is pass-through. A separate 1G RJ-45 network port is provided for access to the iLO management network.

- HPE Edgeline EL4000 10GbE 2xSFP+ Switch System

Supports 1 to 4 full-height, half-length PCIe cards. The core network is Layer 2 switched. A separate 1G RJ-45 network port is provided for access to the iLO management network.

- HPE Edgeline EL4000 10GbE 2xSFP+ Switch PXIe System

Supports 1 to 4 PXIe modules. The core network is Layer 2 switched. A separate 1G RJ-45 network port is provided for access to the iLO management network.

For identification of system components, see the following:

- [PCIe configuration](#) on page 6
- [PXIe configuration](#) on page 9

PCIe configuration

Front panel components

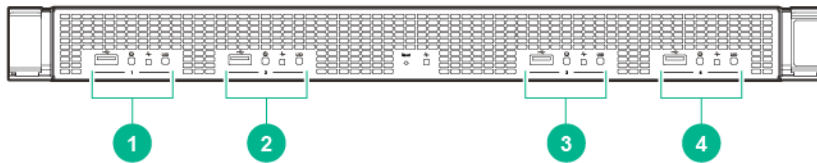

Item	Description
1	Cartridge 1
2	Cartridge 2
3	Cartridge 3
4	Cartridge 4

Front panel LEDs and buttons

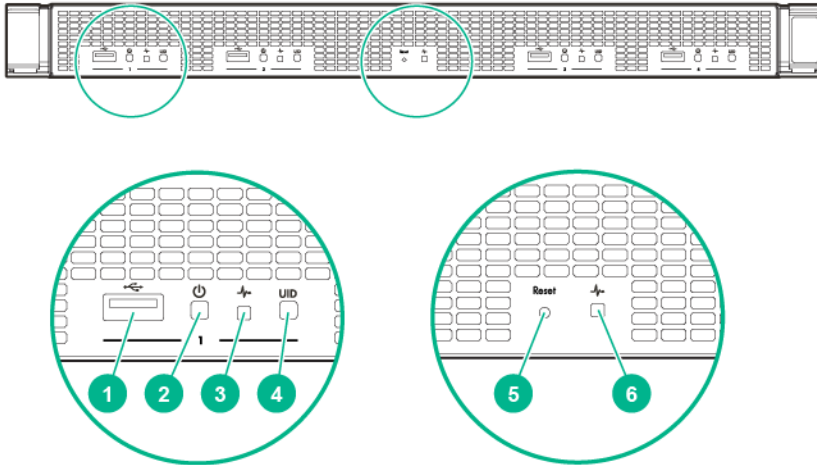

Item	Description	Status
1	USB 2.0 port	Connects a USB 2.0 device to the cartridge
2	Cartridge power LED/ button	Green = Normal operation Amber = Standby operation Off = No power or no cartridge installed
3	Cartridge health LED	Green = Normal operation Flashing Amber = Degraded condition Flashing Red = Critical condition Off = No power or no cartridge installed
4	Cartridge UID LED	Blue = Cartridge ID is selected. Flashing Blue = Cartridge firmware update is in progress or iLO IRC is in use. Off = Cartridge ID is not selected.
5	Management reset pin hole button ¹	Pressing the reset button resets the chassis controller. iLO remains operational.
6	Chassis system health LED	Green = Normal operation Flashing Amber = Degraded condition Off = No power

¹ The reset button is indented and you might need a tool, such as a pin, to press it.

Rear panel components

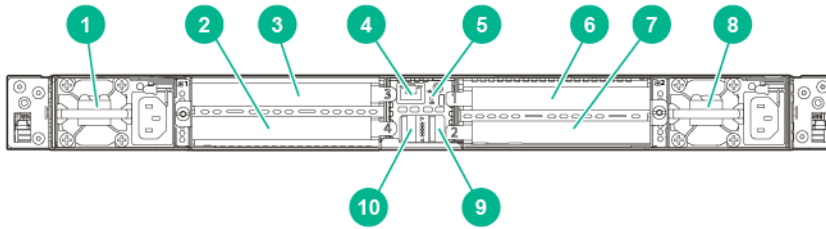

Item	Description
1	Power supply
2	PCIe slot #4 (bottom)
3	PCIe slot #3 (top)
4	iLO port
5	Chassis UID LED
6	PCIe slot #1 (top)
7	PCIe slot #2 (bottom)
8	Power supply
9	QSFP+ Uplink B or SFP+ Uplink B ¹
10	QSFP+ Uplink A or SFP+ Uplink A ¹

¹ Rear components include either QSFP+ or SFP+ ports, depending on configuration.

System board components (PCIe)

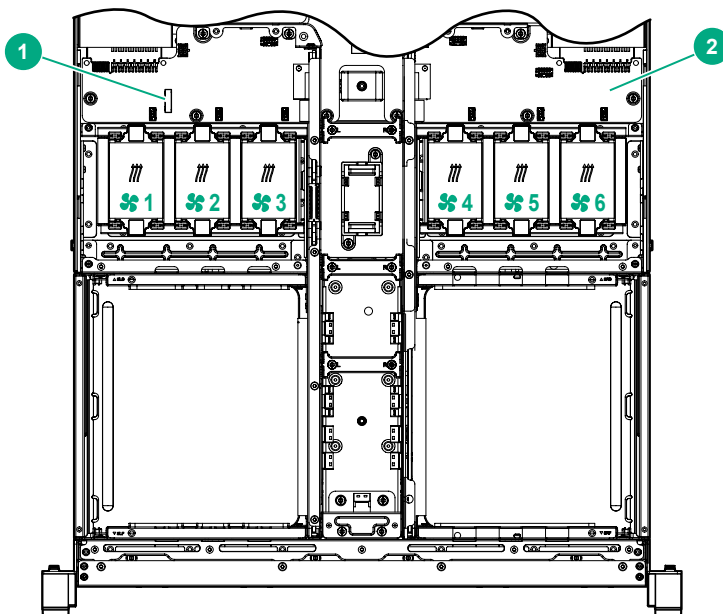

Item	Description
1	System battery
2	System board

Cartridge slot identification

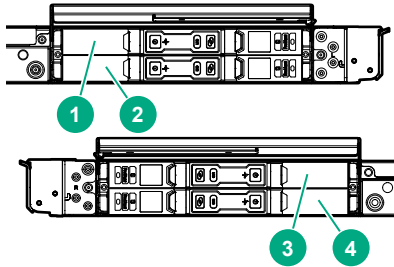

Item	Description
1	Left side, top—Cartridge 1
2	Left side, bottom—Cartridge 2
3	Right side, top—Cartridge 3
4	Right side, bottom—Cartridge 4

PXle configuration

Front panel components

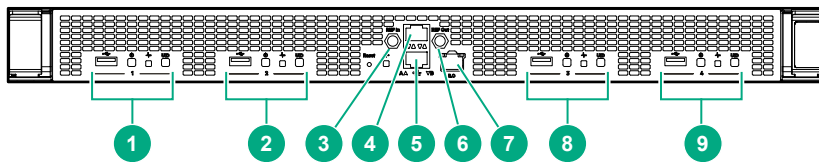

Item	Description
1	Cartridge 1
2	Cartridge 2
3	10 MHz REF OUT clock
4	SFP+ Uplink A connector
5	SFP+ Uplink B connector
6	10 MHz REF IN clock
7	iLO connector

Table Continued

Item	Description
8	Cartridge 3
9	Cartridge 4

Front panel LEDs and buttons

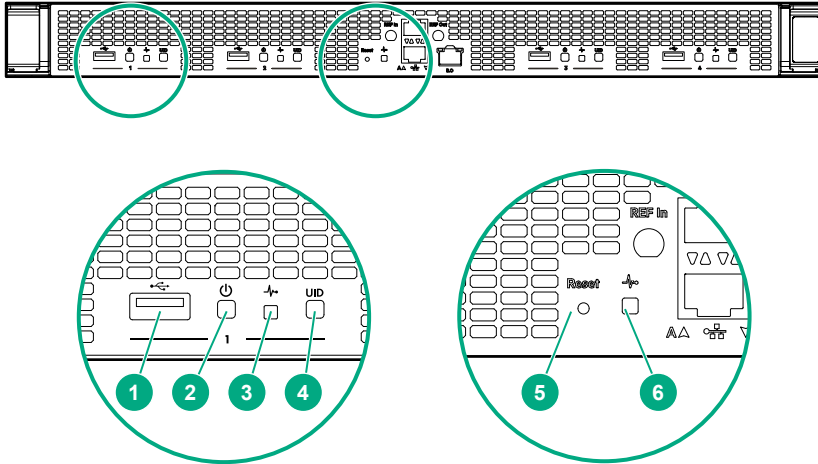

Item	Description	Status
1	USB 2.0 port	Connects a USB 2.0 device to the cartridge
2	Cartridge power LED/ button	Green = Normal operation Amber = Standby operation Off = No power or no cartridge installed
3	Cartridge health LED	Green = Normal operation Flashing Amber = Degraded condition Flashing Red = Critical condition Off = No power or no cartridge installed
4	Cartridge UID LED	Blue = Cartridge ID is selected. Flashing Blue = Cartridge firmware update is in progress or iLO IRC is in use. Off = Cartridge ID is not selected.
5	Management reset pin hole button ¹	Pressing the reset button resets the chassis controller. iLO remains operational.
6	Chassis system health LED	Green = Normal operation Flashing Amber = Degraded condition Off = No power

¹ The reset button is indented and you might need a tool, such as a pin, to press it.

Rear panel components

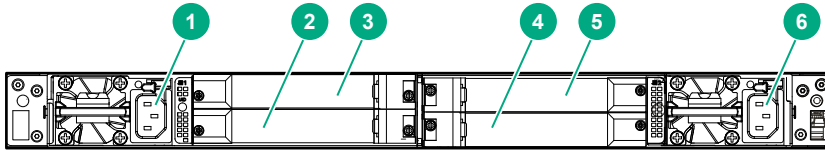

Item	Description
1	Power supply 1
2	PXle slot 4
3	PXle slot 5
4	PXle slot 3
5	PXle slot 2
6	Power supply 2

Rear panel LEDs and buttons

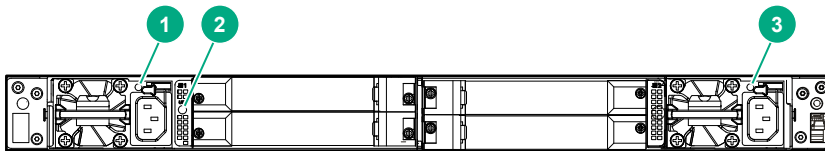

Item	Description
1	Power supply 1 LED
2	Chassis UID LED
3	Power supply 2 LED

System board components (PX1e)

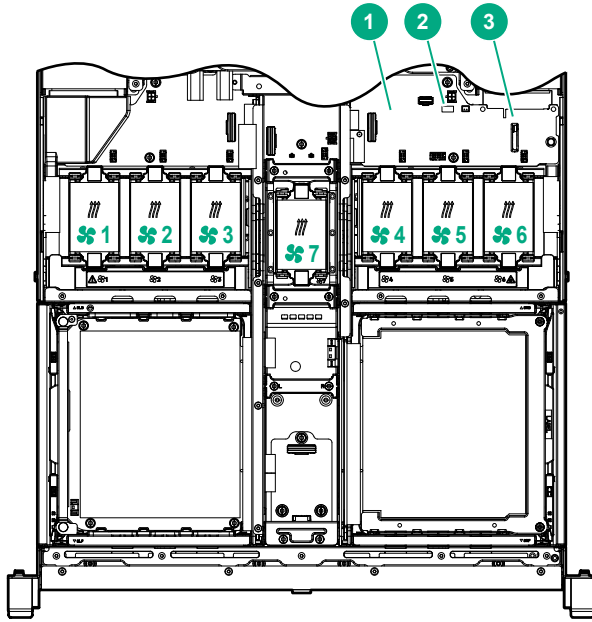

Item	Description
1	System board
2	DIP Switch
3	System battery

DIP switch

Position	Default	Function
S1	Off	<ul style="list-style-type: none"> Off = Fan normal mode On = Fan high mode

Cartridge slot identification

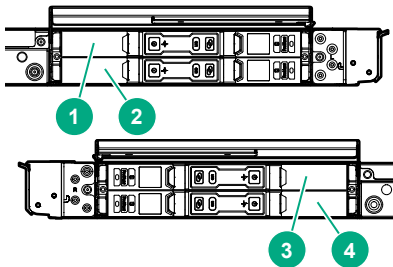

Item	Description
1	Left side, top—Cartridge 1
2	Left side, bottom—Cartridge 2

Table Continued

Item	Description
3	Right side, top—Cartridge 3
4	Right side, bottom—Cartridge 4

Operations

Install an AC power supply

Procedure

1. Align the power supply to the system.
2. Insert the power supply until it locks in place.

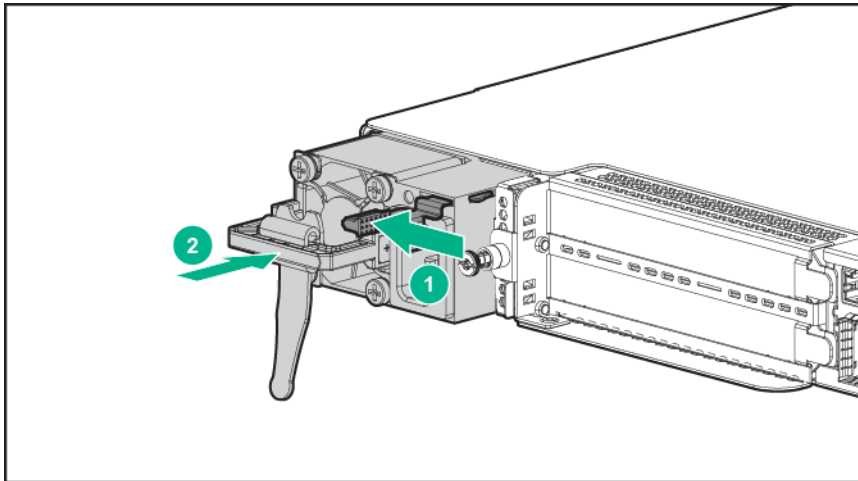

3. Connect the power cord and tie wrap the cable.

You must press the Power On/Off button twice to power on the system.

Install the DC power supply

Procedure

1. Remove the ring tongue from the top of the power supply.

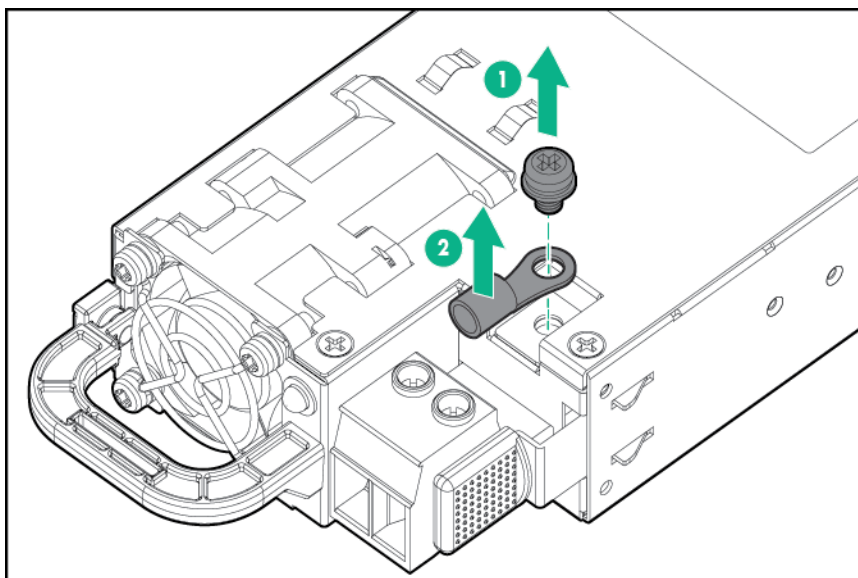

2. Crimp the ring tongue to the ground cable from the -48V power source.

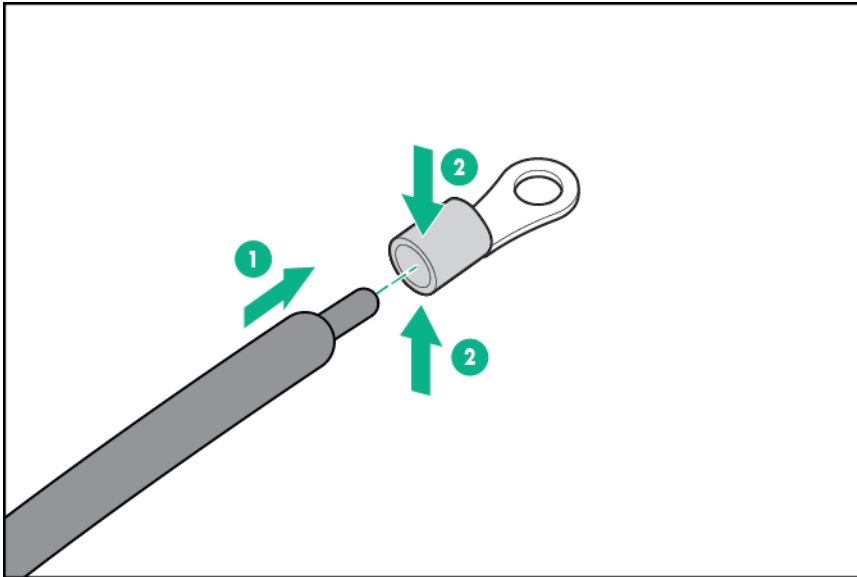

3. Remove the black connector from the rear of the power supply.

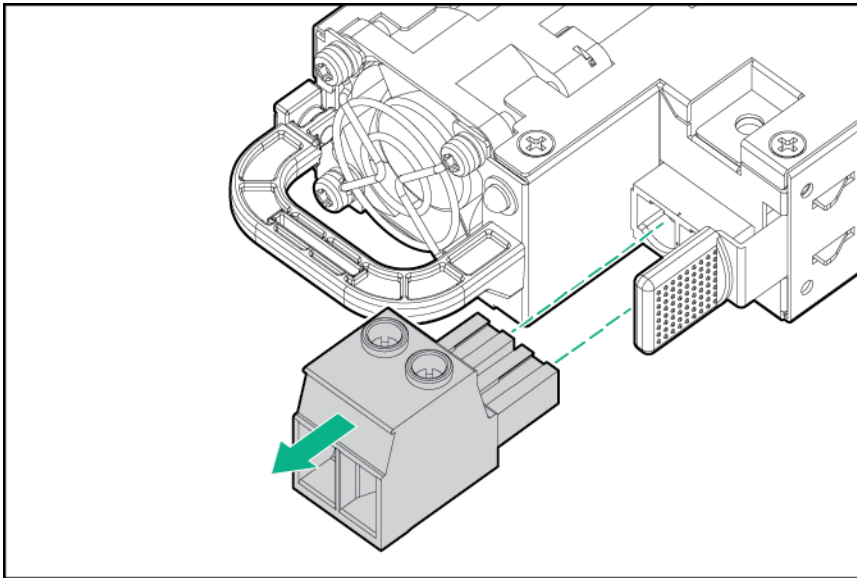

4. Loosen the screws on the connector.

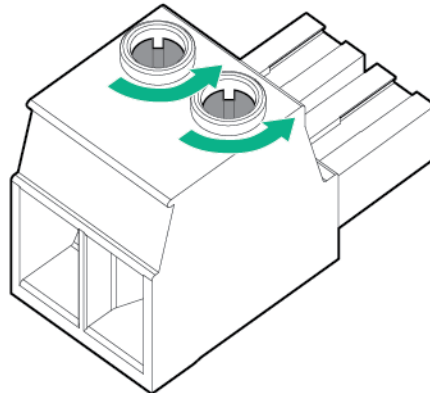

5. Attach the (earthed) cable to the ground screw and washer and tighten to 13 lb-in of torque. The ground cable must be connected before connecting the -48V wire and return wire.

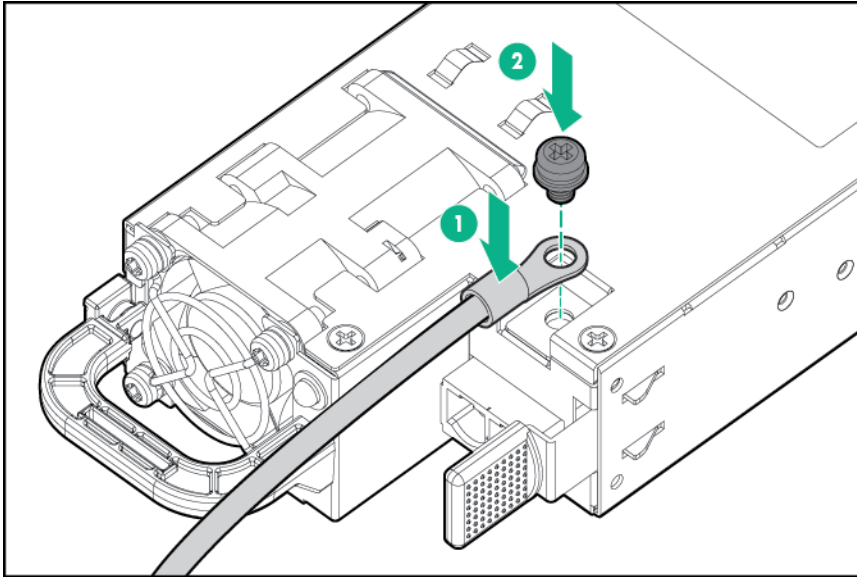

6. Insert the -48V wire into the left side of the connector and tighten the screw to 10 lb-in of torque.

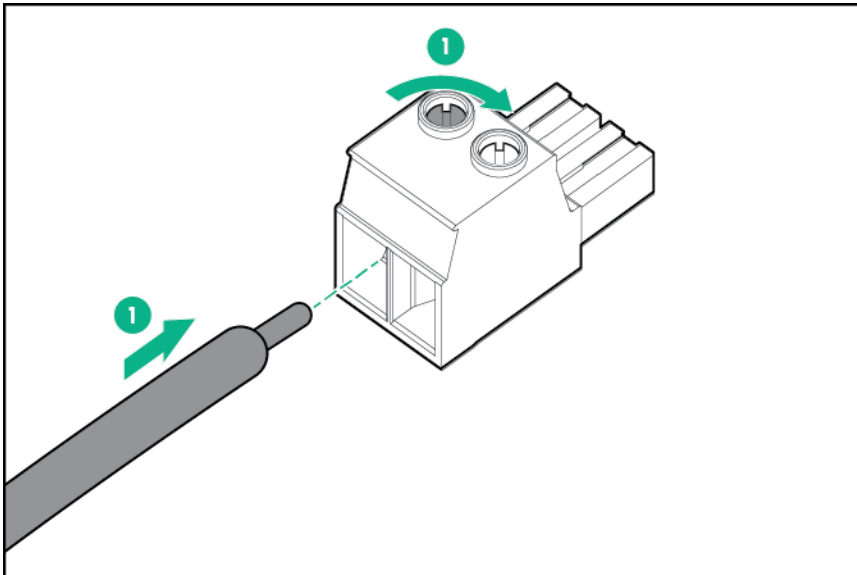

7. Insert the return wire into the right side of the connector and tighten the screw to 10 lb-in of torque.

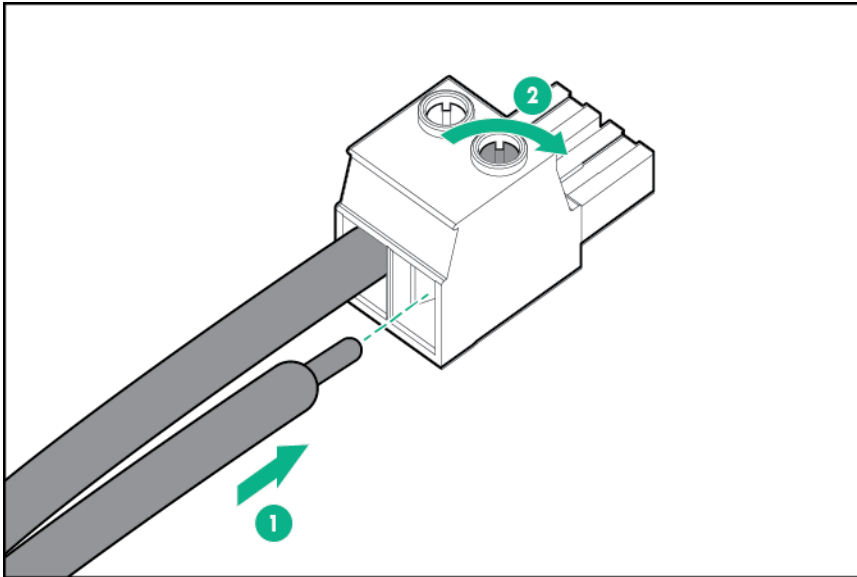

8. Insert the power supply into the power supply bay until it clicks into place.

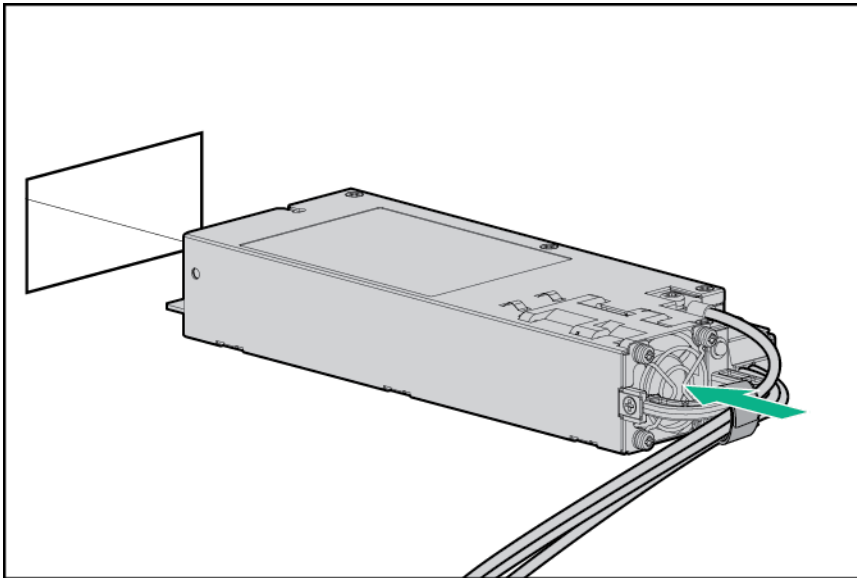

9. Insert the connector into the power supply.

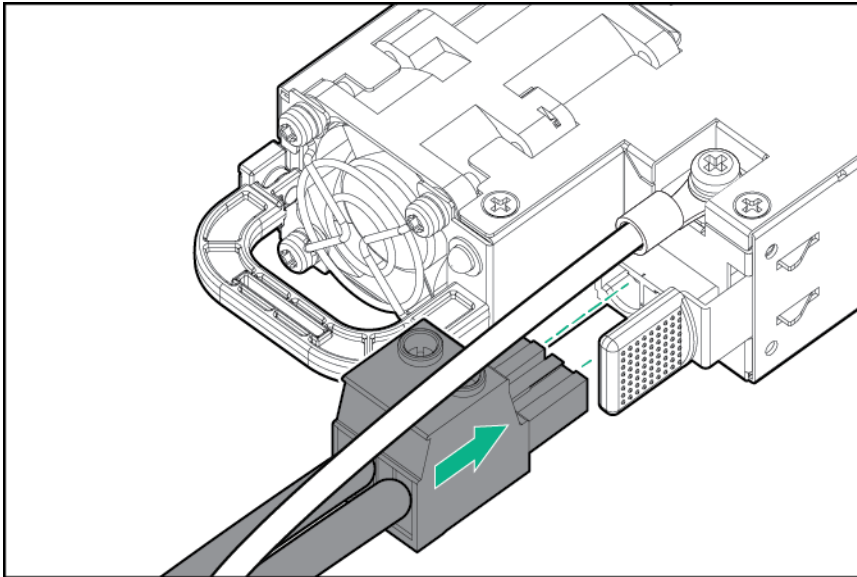

10. Attach the cables to the power supply handle with the hook-and-loop strap.

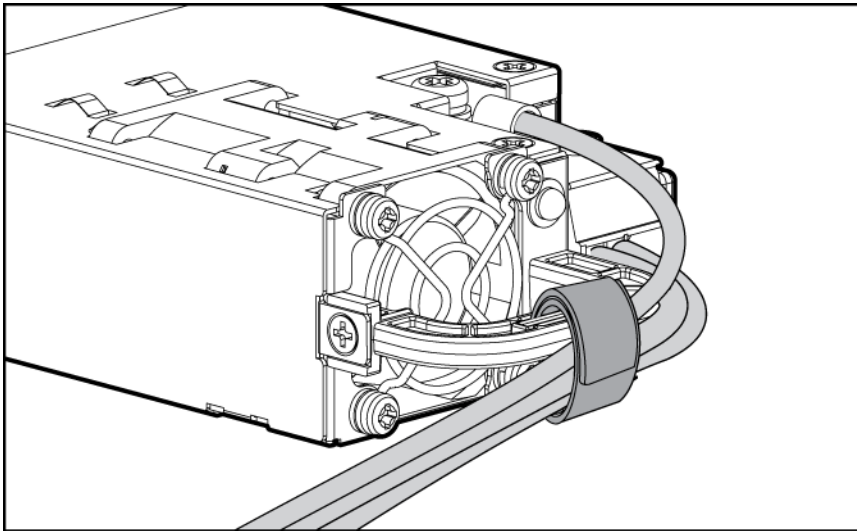

11. Route the power cord. Use best practices when routing power cords and other cables. A cable management arm is available to help with routing. To obtain a cable management arm, contact a Hewlett Packard Enterprise authorized reseller.
12. Make sure the -48V DC power source is off or the PDU breaker is in the off position, and then connect the power cord to the -48V DC power source or PDU.
13. Turn on the -48V power source or switch the PDU breaker to the on position to supply -48V to the power supply.
14. Be sure that the green power supply LED is on.

Install a power supply blank

Procedure

1. Align the power supply blank to the unused power supply bay on the system, and insert until it locks in place.

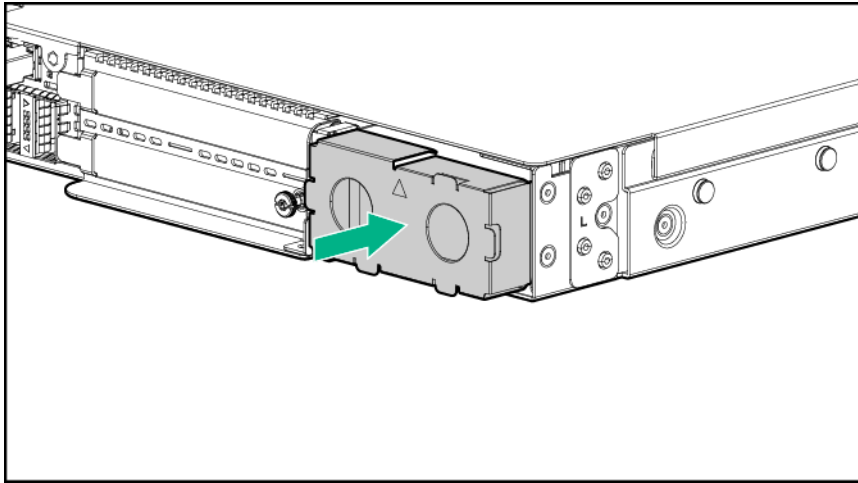

Power down the system

About this task

Before powering down the system for any upgrade or maintenance procedures, back up critical system data and programs.

Before performing chassis maintenance, shut down all cartridges installed in the system.

Procedure

- Use one of the following methods to power down the system:
 - Press and release the Power On/Standby button of the cartridges installed in the system.

This method initiates a controlled shutdown of applications and the OS before the system enters standby mode.
 - Press and hold the Power On/Standby button of the cartridges installed in the system for more than 4 seconds to force the system to power down.

This method forces the system to power down without properly exiting applications and the OS. If an application stops responding, you can use this method to force a shutdown.

Verify the system is in standby mode and the system power LED is off.

Power up the system

About this task

If the system is connected to a power source, it powers up automatically by default. Generally, it has to be powered up only after a manual shutdown. However, using iLO, cartridges can be individually configured to not power up automatically.

Procedure

- Use one of the following methods to power up the system:
 - Press the Power On/Standby button of the cartridge installed in the system.
 - Remotely power up the system through iLO.

Mount the system

The following kits are available to mount your system:

- Rack-mounting kit
- Wall-mounting kit

The wall-mounting kit is non HPE and allows up to two Edgeline EL4000 systems to be installed on a wall. For more details, contact RackSolutions® at <http://www.racksolutions> and request P/N 101-5302.

Remove the access panel

Depending on the configuration of your system, perform one of the following procedures:

- [Removing the PCIe access panel](#) on page 20
- [Removing the PXle access panel](#) on page 20

Removing the PCIe access panel

Procedure

1. Using a Torx screwdriver, turn the T-15 locking Torx screw a quarter turn to unlock the latch.
2. Press the latch button and open the latch.
3. Remove the access panel.

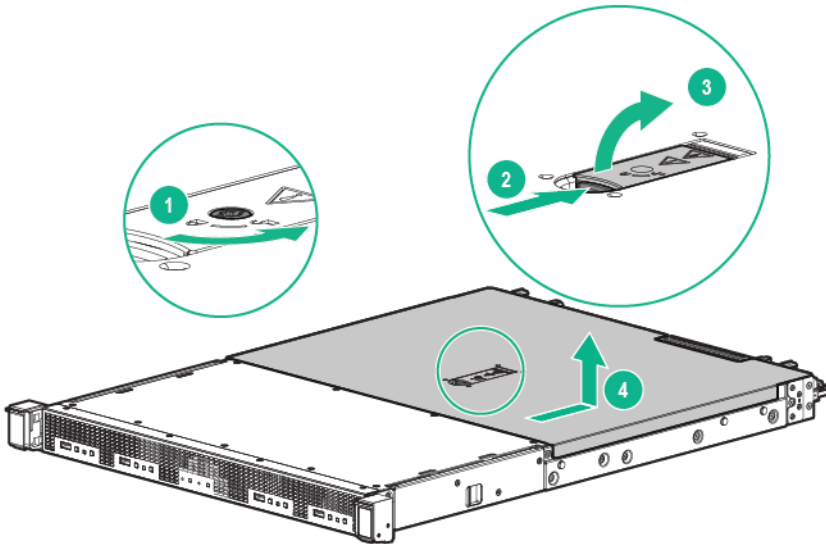

Removing the PXle access panel

Procedure

1. Press the latch button and open the latch.
2. Slide the panel to the rear of the chassis.
3. Lift and remove the access panel.

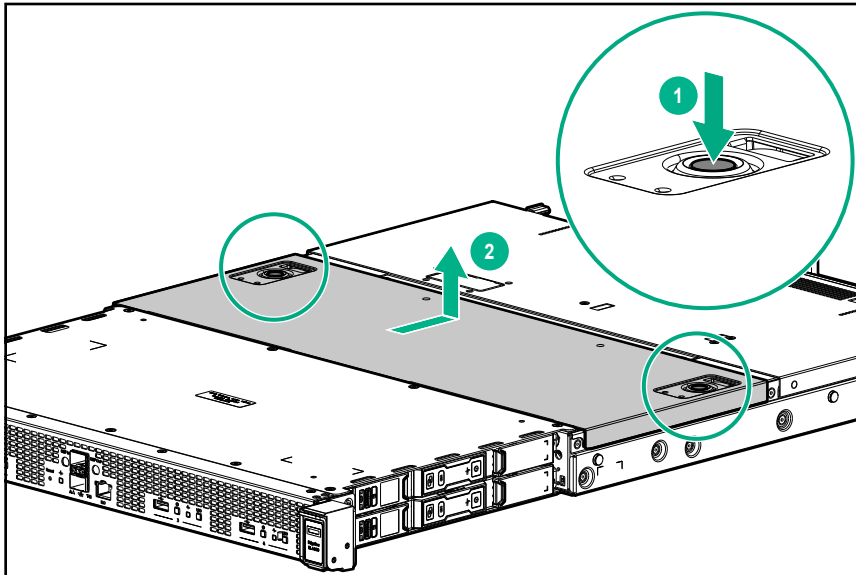

Remove the fixed top cover

Depending on the configuration of your system, perform one or more of the following procedures:

- **Removing the fixed top cover of the PCIe system** on page 21
- **Removing the fixed front top cover of the PXle system** on page 21
- **Removing the fixed rear top cover of the PXle system** on page 22

Removing the fixed top cover of the PCIe system

Procedure

1. Using a Torx screwdriver, remove the nine T-10 Torx screws securing the fixed top cover to the system.

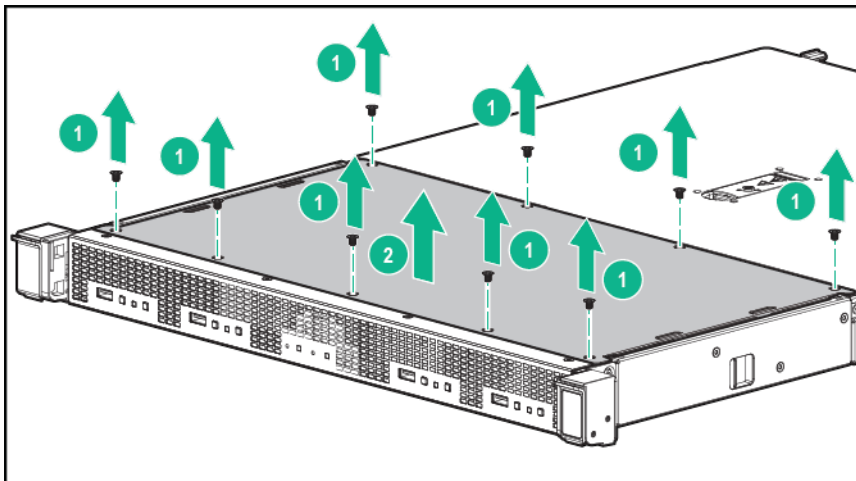

Removing the fixed front top cover of the PXle system

Procedure

1. Using a Torx screwdriver, remove the 10 T-10 Torx screws securing the fixed front top cover to the system.

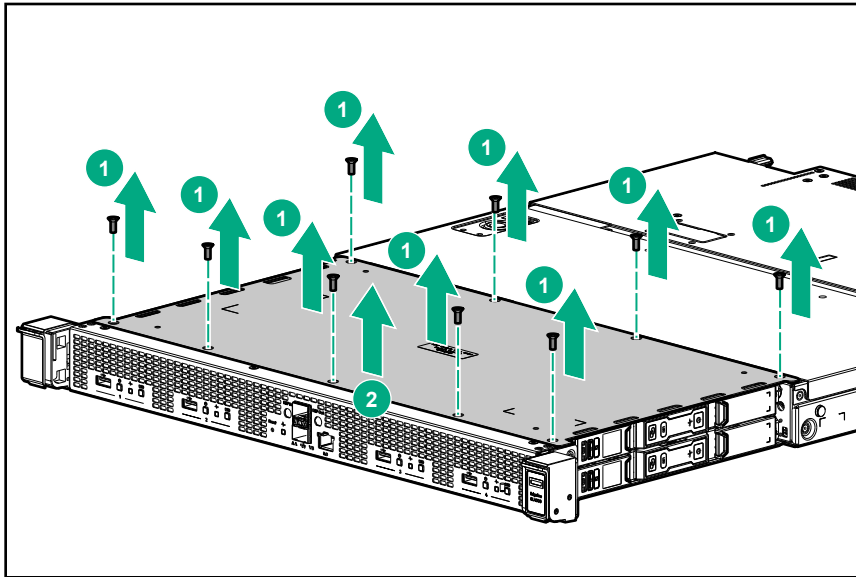

Removing the fixed rear top cover of the PXle system

Procedure

1. Remove the PXle access panel ([Removing the PXle access panel](#) on page 20).
2. Using a Torx screwdriver, remove the 14 T-10 Torx screws securing the fixed rear top cover to the system.

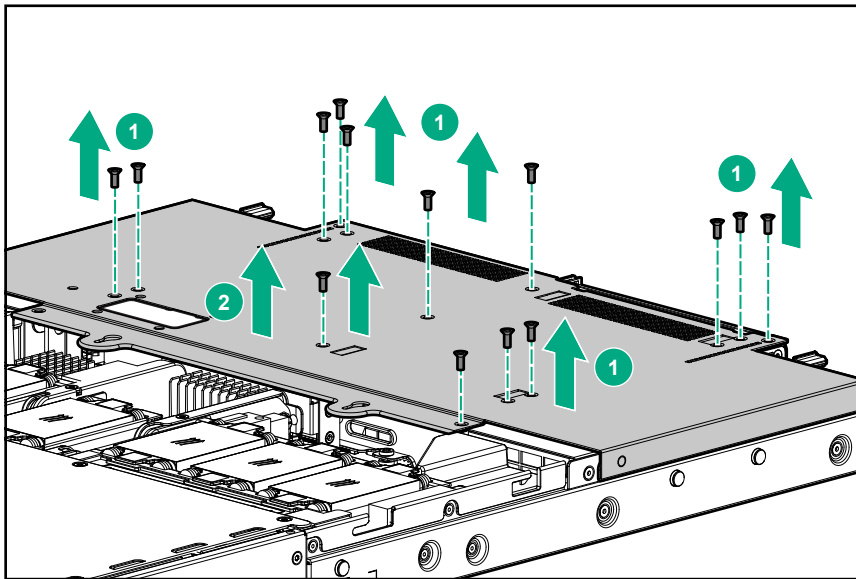

Install the fans

Procedure

1. Align the fan with the fan slots of the system.
2. Squeeze the tabs on either side of the fan, and then slide it into the bay until it clicks in place.

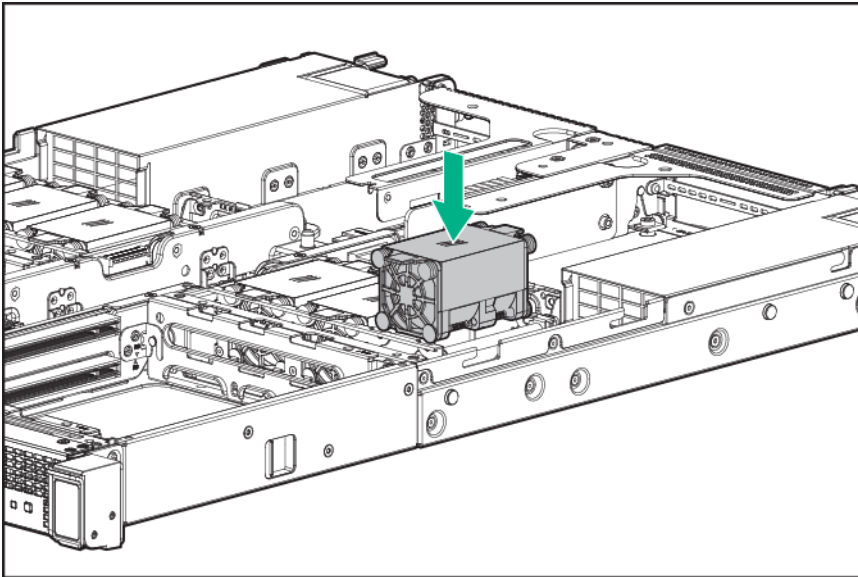

3. Connect the fan cable to the board.



Install the cartridge

Procedure

1. Align and install the cartridge into the system.
 - a. For cartridges 1 and 2 (left side), the cartridges must be inserted with the processor facing up.

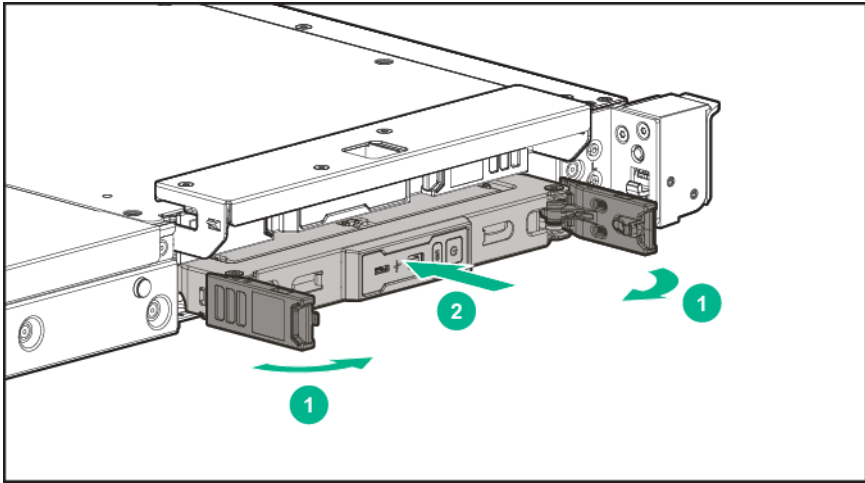

- b. For cartridges 3 and 4 (right side)*, the cartridges must be inserted with the processor facing down.
*Cartridges 3 and 4 will appear upside down from image.

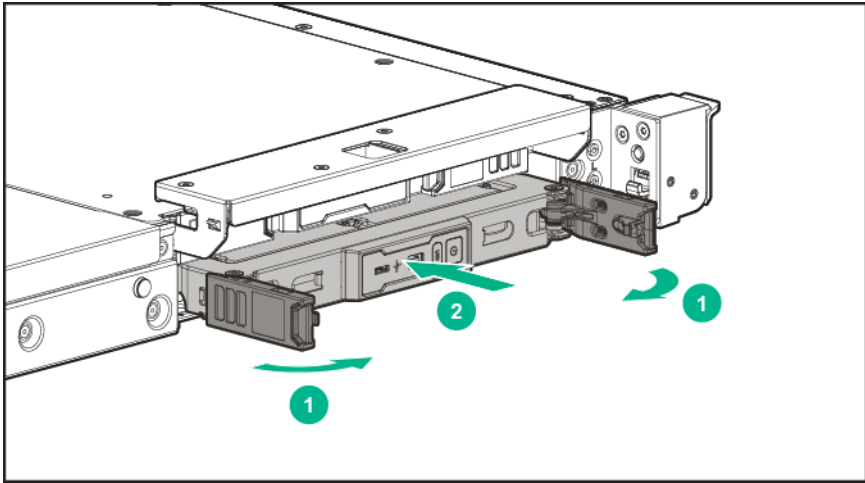

Setup

Optional services

Hewlett Packard Enterprise offers the HPE Foundation Care Next Business Day Exchange Service for this product.

HPE Foundation Care Next Business Day Exchange Service provides a replacement product or part delivered free of freight charges to your location the next business day after a call is opened and provides support 24 hours per day, Monday through Sunday.

Hardware exchange offers a reliable and fast parts exchange service for eligible Hewlett Packard Enterprise products. Specifically targeted at products that can easily be shipped and on which you can easily restore data from backup files, HPE Foundation Care Next Business Day Exchange is a cost-efficient and convenient alternative to onsite support.

Replacement products or parts are new or equivalent to new in performance.

In addition, HPE Foundation Care Next Business Day Exchange provides electronic access to related product and support information, enabling any member of your IT staff to locate commercially available essential information.

For more information on HPE Foundation Care Next Business Day Exchange Service, see the [Hewlett Packard Enterprise website](#).

Optimum environment

When installing the system, select a location that meets the environmental standards.

- [Space and airflow requirements](#) on page 25
- [Temperature requirements](#) on page 25
- [Power requirements](#) on page 25

Space and airflow requirements

To allow for servicing and adequate airflow, leave a minimum clearance of 20 cm (7.9 in.) around the system.

Temperature requirements

To ensure continued safe and reliable equipment operation, install or position the system in a well-ventilated, climate-controlled environment.

Configuration	Temperature
Chassis with cartridges installed, but no PCIe cards/PXle modules installed	Operating temperature of up to 55°C (131°F)

Power requirements

Installation of this equipment must comply with local and regional electrical regulations governing the installation of information technology equipment by licensed electricians. This equipment is designed to operate in installations covered by NFPA 70, 1999 Edition (National Electric Code) and NFPA-75, 1992 (code for Protection of Electronic Computer/Data Processing Equipment). For electrical power ratings on options, see the product rating label or the user documentation supplied with that option.

More Information

[Power supply specifications](#) on page 47

Installing hardware options

Install any hardware options before initializing the system. For options installation information, see the option documentation. For system-specific information, see "[Hardware options installation](#)."

Registering the product

To experience quicker service and more efficient support, register the product at the [Hewlett Packard Enterprise Product Registration website](#).

Hardware options installation

Installing the short extension rail kit

About this task

For detailed instructions, see the instructions that ship with the rack rail hardware kit.

Procedure

1. Attach the rails to the system.
2. Attach the rails to the front of the rack.
3. Attach the rails to the rear of the rack.

Align the system with the rails, and slide into the rack.

Installing the full extension rail kit with cable management arm

About this task

For detailed instructions, see the instructions that ship with the rack rail hardware kit.

Procedure

1. Attach the rails to the system.
2. Attach the rails to the front of the rack.
3. Attach the rails to the rear of the rack.

Align the system with the rails, and slide into the rack.

Configuration

Networking in the chassis

HPE EL4000 4x10G 2xQSFP+ PThru System networking

This configuration has two external 40GbE QSFP+ ports, labelled A and B. The NIC A of each of the four cartridges is connected to the external port A. The NIC B of each cartridge is connected to the external port B through a single 10G lane within the 40GbE port. The connection is a pass-through one, as the cartridge 10G NIC port is routed directly to the external port. If required, VLAN segmentation can be configured at the external switch, based on the ports to which the cartridges are connected.

To connect to an external switch, you can use one of the following methods:

- Using a 40G to 4x10G breakout copper or optical transceiver solution.

Each of the 10G strands of the breakout cable is a 10GbE connection to a cartridge in the chassis. On the HPE 40G to 4x10G DAC cable, the 10G breakout cable labeled A is connected to Cartridge 1. The 10G breakout cable marked B is connected to Cartridge 2, and so on. Each of these cables can be connected to a 10GbE SFP+ port on an external switch.

- Using a 40G to 40G copper or optical transceiver.

This 40G connection is actually four 10GbE connections carried within a single cable. At the external switch, the port to which this cable connects must be configured in 4x10GbE mode, rather than the native 40GbE mode. Any per-cartridge port configuration in the external switch is applied to the component 10G port within the 40G port.

HPE EL4000 10G 2xSFP+ Switch System networking

This configuration has two external 10GbE SFP+ ports, labelled A and B. The NIC A of each of the four cartridges is internally switched within the system to the external 10GbE SFP+ port labelled A. Unicast packets to a cartridge are sent only to that cartridge, while multicast or broadcast packets are sent to all cartridges.

For VLAN segmentation, you can use one of the following methods:

- If all the NIC As are in the same VLAN, that VLAN can be configured at the port of the external switch to which the system port A is connected. Similarly, all of the NIC Bs may be configured in another VLAN if necessary.
- If each cartridge must be in a different VLAN, then VLAN tagging must be configured at the cartridge, typically at the operating system level. The port of the external switch to which the EL4000 network port is attached must be configured as a trunk port. Appropriate configuration of the tagged VLAN used by the system must be done at the external switch. VLAN 1 is always treated as the untagged default VLAN.

HPE EL4000 10G 2SFP+ Switch Pxi System networking (data capture and control)

This configuration has two external 10GbE SFP+ ports, labelled A and B. The NIC A of each of the four cartridges is internally switched to the external 10GbE SFP+ port labelled A. Unicast packets to a cartridge are sent only to that cartridge, while multicast or broadcast packets are sent to all cartridges.

For VLAN segmentation, you can use one of the following methods:

- If all the NIC As are in the same VLAN, that VLAN can be configured at the port of the external switch to which the system port A is connected. All of the NIC Bs can be configured to be in another VLAN.
- If each cartridge must be in a different VLAN, then VLAN tagging must be configured at the cartridge, typically at the operating system level. The port of the external switch to which the EL4000 network port is attached must be configured as a trunk port. Appropriate configuration of the tagged VLAN used by the system must be done at the external switch. VLAN 1 is always treated as the untagged

default VLAN. VLAN 2 and VLAN 3 are used internally by the embedded switch within the system, and cannot be configured as tagged VLANs on the cartridges.

Accessing the System Utilities menu

About this task

To complete these steps, you need the HPE USB-to-serial cable (HPE part number 871947-B21).

Table 1: Settings for connecting USB cable to serial port

Specifications	Value
Baud rate	115200
Data bits	8
Parity	None
Stop bit	1 (8 N1)

Procedure

1. Power down the cartridge.
2. Connect the USB-to-serial cable to the system. The USB end is connected to a system USB port.
3. Attach the serial end of the cable to a serial port using a null modem cable. The other serial port may be another USB-to-serial adapter on a different machine.
4. Power on the cartridge. The serial console output screen displays.

```
(C) Copyright 1982 - 2016 Hewlett Packard Enterprise Development LP
HP ProLiant m710x Server Cartridge
BIOS Version: H07 v1.10 (08/05/2016)
Serial Number:

System Memory: 16 GB
1 Processor(s) detected, 4 total cores enabled, Hyperthreading is enabled
Proc 1: Intel(R) Xeon(R) CPU E3-1585 v5 @ 3.50GHz

HPE Power Profile Mode: Balanced Power and Performance
Power Regulator Mode: Dynamic Power Savings
Boot Mode: UEFI

For access via BIOS Serial Console:
Press 'ESC+9' for System Utilities
Press 'ESC+0' for Intelligent Provisioning
Press 'ESC+!' for One-Time Boot Menu
Press 'ESC+@' for Network Boot

Starting drivers. Please wait, this may take a few moments...

█
```

5. Press the **ESC + 9** keys. The System Utilities menu displays.

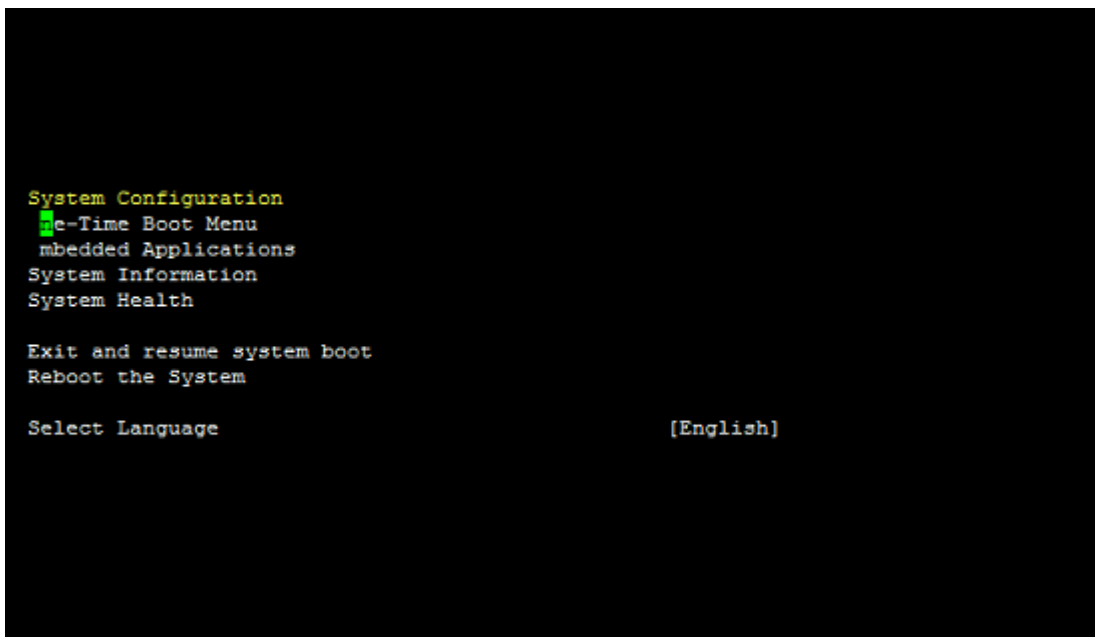

Viewing or updating the DHCP address using the serial console cable

Procedure

1. **Access the System Utilities menu.**
2. Navigate through the menu options **System Configuration > iLO 4 Configuration Utility > Network > DNS/DHCP**, and press **Enter**. The **Network Autoconfiguration** screen displays.
3. View or update the DHCP settings.
4. To save any changes, press the **F10** key.
5. After saving all settings, iLO prompts for a reset in order for any new settings to be used. Reset the system.

Finding the IP address through DHCP

Procedure

1. **Access the System Utilities menu.**
2. Navigate through the menu options **System Configuration > iLO 4 Configuration Utility > Network Options**.
3. The Network Options screen displays the IP address.

```
iLO 4 Configuration Utility

Network Options

MAC Address                [14:02:EC:00:BA:68]
Network Interface Adapter  [ON]
Transceiver Speed Autoselect [ON]

DHCP Enable                [OFF]
DNS Name                   [ILOCN66310D4W]

IP Address                 [172.27.10.100]
Subnet Mask                [255.255.0.0]
Gateway IP Address         [0.0.0.0]
```

Setting the static IP address using the serial console cable

Procedure

1. **Access the System Utilities menu.**
2. Navigate through the menu options **System Configuration > iLO 4 Configuration Utility > Network Options**. The Network Options screen displays.
3. Change **DHCP Enable** to **OFF**.
4. Configure the **IP Address**, **Subnet Mask**, and **Gateway Address** as required. The following image is an example of a completed **Network Options** screen.

```
iLO 4 Configuration Utility

Network Options

MAC Address                [14:02:EC:00:BA:68]
Network Interface Adapter  [ON]
Transceiver Speed Autoselect [ON]

DHCP Enable                [OFF]
DNS Name                   [ILOCN66310D4W]

IP Address                 [172.27.10.100]
Subnet Mask                [255.255.0.0]
Gateway IP Address        [0.0.0.0]
```

5. Once completed, press **ESC** to back out of the menus. Save the settings when prompted.
6. After saving all settings, iLO prompts for a reset in order for the new settings to be used. Reset the system.

Software and configuration utilities

Product QuickSpecs

For more information about product features, specifications, options, configurations, and compatibility, see the product QuickSpecs on the [Hewlett Packard Enterprise website](#).

Supported operating systems and drivers matrix

To validate the minimum supported Operating System for a system platform, go to the Hewlett Packard Enterprise website:

<http://www.hpe.com/info/ossupport>

To download the latest device drivers, go to the Hewlett Packard Enterprise Support Center website:

<http://www.hpe.com/support/hpesc>

HPE iLO

iLO is a remote server management processor embedded on the system boards of HPE ProLiant and Synergy servers. iLO enables the monitoring and controlling of servers from remote locations. HPE iLO management is a powerful tool that provides multiple ways to configure, update, monitor, and repair servers remotely. iLO (Standard) comes preconfigured on HPE servers **without an additional cost or license**.

Features that enhance server administrator productivity are licensed. For more information, see the iLO documentation on the [Hewlett Packard Enterprise website](#).

Active Health System

The Active Health System monitors and records changes in the server hardware and system configuration.

The Active Health System provides:

- Continuous health monitoring of over 1600 system parameters
- Logging of all configuration changes
- Consolidated health and service alerts with precise time stamps
- Agentless monitoring that does not affect application performance

The Agentless Management Service is available in the SPP, which can be downloaded from the [Hewlett Packard Enterprise website](#). The Active Health System log can be downloaded manually from iLO 4 or Intelligent Provisioning and sent to Hewlett Packard Enterprise.

For more information, see the following documents:

- *iLO User Guide* on the [Hewlett Packard Enterprise website](#)
- *Intelligent Provisioning User Guide* on the [Hewlett Packard Enterprise website](#)

Active Health System data collection

The Active Health System does not collect information about your operations, finances, customers, employees, or partners.

Examples of data that is collected:

- Server model and serial number
- Processor model and speed

- Storage capacity and speed
- Memory capacity and speed
- Firmware/BIOS and driver versions and settings

The Active Health System does not parse or change operating system data from third-party error event log activities (for example, content created or passed through the operating system).

Active Health System log

The data collected by the Active Health System is stored in the Active Health System Log. The data is logged securely, isolated from the operating system, and separate from customer data.

When the Active Health System Log is full, new data overwrites the oldest data in the log.

It takes less than 5 minutes to download the Active Health System Log and send it to a Hewlett Packard Enterprise support professional to help you resolve an issue.

When you download and send Active Health System data to Hewlett Packard Enterprise, you agree to have Hewlett Packard Enterprise use the data for analysis, technical resolution, and quality improvements. The data that is collected is managed according to the privacy statement, available on the [Hewlett Packard Enterprise website](#).

iLO RESTful API support

HPE iLO 4 firmware version 2.00 and later includes the iLO RESTful API. The iLO RESTful API is a management interface that server management tools can use to perform configuration, inventory, and monitoring of the ProLiant server via iLO. The iLO RESTful API uses basic HTTPS operations (GET, PUT, POST, DELETE, and PATCH) to submit or return JSON-formatted data with iLO web server.

HPE iLO 4 2.30 and later is Redfish 1.0-conformant while remaining backward compatible with the existing iLO RESTful API.

HPE iLO 4 supports the iLO RESTful API with ProLiant Gen8 and later servers. For more information about the iLO RESTful API, see the [Hewlett Packard Enterprise website](#).

Integrated Management Log

The IML records hundreds of events and stores them in an easy-to-view form. The IML timestamps each event with one-minute granularity.

You can view recorded events in the IML in several ways, including the following:

- From within HPE SIM
- From within the UEFI System Utilities
- From within the Embedded UEFI shell
- From within operating system-specific IML viewers:
 - For Windows: IML Viewer
 - For Linux: IML Viewer Application
- From within the iLO web interface
- From within Insight Diagnostics

HPE Insight Cluster Management Utility

The Insight CMU is an efficient and robust hyperscale cluster lifecycle management framework and suite of tools for large Linux clusters. A simple graphical interface enables an at-a-glance view of the entire cluster across multiple metrics, provides frictionless scalable remote management and analysis, and allows rapid software provisioning to all system nodes. Insight CMU makes cluster management more user friendly, efficient, and error-free than if it were being managed by scripts, or on a node-by-node basis. Insight CMU is highly flexible and customizable, offers both GUI and CLI interfaces, and is used to

deploy a range of software environments, from simple compute farms to highly customized, application-specific configurations.

For more information on Insight CMU features and links to technical documentation, QuickSpecs, and a product demo, see the [Hewlett Packard Enterprise website](#).

To download the product, go to the [Hewlett Packard Enterprise Software Depot](#). Click **Insight Management**, then click **Insight Cluster Management**.

HPE Edgeline Component Pack

The HPE Edgeline Component Pack is a comprehensive firmware solution tested on the Edgeline System and delivered as a compressed file. The compressed file includes all the component files needed to update an Edgeline System. Users deploy the firmware updates contained in the HPE Edgeline Component Pack using the included Smart Update Manager, or by updating using the firmware update capability of the iLO 4 on each server cartridge. Download the latest pack from the [Hewlett Packard Enterprise website](#).

HP Smart Update Manager

HP SUM is an application included with the HPE Edgeline Component Pack that provides a web-based GUI for installing and updating firmware on many Hewlett Packard Enterprise products, including the Edgeline System. HP SUM has an integrated discovery engine that finds the installed hardware and current versions of firmware in use on nodes you identify. The application installs updates in the correct order and ensures that all dependencies are met before deploying an update, and prevents an installation if there are version-based dependencies that it cannot resolve.

The version of HP SUM included with each HPE Edgeline Component Pack release is designed to be the best solution for installing Edgeline System firmware updates. Always use the included version of HP SUM for Edgeline System updates. For more information, see the *HPE Edgeline Component Pack Update Guide* in the [Hewlett Packard Enterprise Information Library](#).

UEFI System Utilities

The UEFI System Utilities is embedded in the system ROM. The UEFI System Utilities enable you to perform a wide range of configuration activities, including:

- Configuring system devices and installed options
- Enabling and disabling system features
- Displaying system information
- Selecting the primary boot controller
- Configuring memory options
- Selecting a language
- Launching other preboot environments such as the Embedded UEFI Shell and Intelligent Provisioning

For more information, see the UEFI System Utilities user guide for your product on the [Hewlett Packard Enterprise website](#).

To access mobile-ready online help for the UEFI System Utilities and UEFI Shell, scan the QR code at the bottom of the screen. For on-screen help, press the **F1** key.

Using UEFI System Utilities

To use the System Utilities, use the following keys.

Action	Key
Access System Utilities	F9 during server POST
Navigate menus	Up and Down arrows
Select items	Enter
Save selections	F10
Access Help for a highlighted configuration option ¹	F1

¹ Scan the QR code on the screen to access online help for the UEFI System Utilities and UEFI Shell.

Default configuration settings are applied to the server at one of the following times:

- Upon the first system power-up
- After defaults have been restored

Default configuration settings are sufficient for typical server operations; however, you can modify configuration settings as needed. The system prompts you for access to the UEFI System Utilities each time the system is powered up.

Flexible boot control

This feature enables you to do the following:

- Add Boot Options:
 - Browse all FAT16 and FAT32 file systems.
 - To add a new UEFI boot option, select an X64 UEFI application with an .EFI extension. For example, adding an OS boot loader or other UEFI application as a new UEFI boot option.

The new boot option is appended to the boot-order list. When you select a file, you are prompted to enter the boot option description. This description, and any optional data to be passed to an .EFI application, is then displayed in the boot menu.
- Boot to System Utilities

After pre-POST, the boot options screen appears. During this time, you can access the UEFI System Utilities by pressing the **F9** key.
- Choose between supported modes:
 - Legacy BIOS Boot Mode
 - UEFI Boot Mode



IMPORTANT:

If the default boot mode settings are different than the user-defined settings, the system might not boot the OS installation if the defaults are restored. To avoid this issue, use the User Defined Defaults feature in UEFI System Utilities to override the factory default settings.

For more information, see the UEFI System Utilities user guide for your product on the [Hewlett Packard Enterprise Information Library](#).

Restoring and customizing configuration settings

You can reset all configuration settings to the factory default settings, or you can restore and use the system default configuration settings.

You can also configure default settings as necessary, and then save the configuration as the custom default configuration. When the system loads the default settings, it uses the custom default settings instead of the factory defaults.

Secure Boot configuration

Secure Boot is integrated in the UEFI specification on which the Hewlett Packard Enterprise implementation of UEFI is based. Secure Boot is implemented in the BIOS and does not require special hardware. Secure Boot ensures that each component launched during the boot process is digitally signed. Secure Boot also ensures that the signature is validated against a set of trusted certificates embedded in the UEFI BIOS. Secure Boot validates the software identity of the following components in the boot process:

- UEFI drivers loaded from PCIe cards
- UEFI drivers loaded from mass storage devices
- Preboot UEFI shell applications
- OS UEFI boot loaders

When enabled, only firmware components and operating systems with boot loaders that have an appropriate digital signature can execute during the boot process. Only operating systems that support Secure Boot and have an EFI boot loader signed with one of the authorized keys can boot. For more information about supported operating systems, see the UEFI System Utilities and Shell release notes for your system on the [Hewlett Packard Enterprise website](#).

A physically present user can customize the certificates embedded in the UEFI BIOS by adding or removing their own certificates.

When Secure Boot is enabled, the System Maintenance Switch does not restore all manufacturing defaults when set to the ON position. For security reasons, the following are not restored to defaults when the System Maintenance Switch is in the ON position:

- Secure Boot is not disabled and remains enabled.
- The Boot Mode remains in UEFI Boot Mode even if the default boot mode is Legacy Boot Mode.
- The Secure Boot Database is not restored to its default state.
- iSCSI Software Initiator configuration settings are not restored to defaults.

Embedded UEFI shell

The system BIOS in all ProLiant Gen9 servers includes an Embedded UEFI Shell in the ROM. The UEFI Shell environment provides an API, a command-line prompt, and a set of CLIs that allow scripting, file manipulation, and system information. These features enhance the capabilities of the UEFI System Utilities.

For more information, see the following documents:

- *UEFI Shell User Guide for HPE ProLiant Gen9 Servers* on the [Hewlett Packard Enterprise website](#)
- *UEFI Shell Specification* on the [UEFI website](#)

Embedded Diagnostics option

The system BIOS in all ProLiant Gen9 servers includes an Embedded Diagnostics option in the ROM. The Embedded Diagnostics option can run comprehensive diagnostics of the server hardware, including processors, memory, drives, and other server components.

For more information on the Embedded Diagnostics option, see the UEFI System Utilities user guide for your system on the [Hewlett Packard Enterprise website](#).

iLO RESTful API support for UEFI

The ProLiant Gen9 servers include support for a UEFI-compliant System BIOS, along with UEFI System Utilities and Embedded UEFI Shell preboot environments. ProLiant Gen9 servers also support configuring the UEFI BIOS settings using the iLO RESTful API, a management interface that server management tools can use to perform configuration, inventory, and monitoring of a ProLiant server. The iLO RESTful API uses basic HTTPS operations (GET, PUT, POST, DELETE, and PATCH) to submit or return JSON-formatted data with iLO web server.

For more information about the iLO RESTful API and the RESTful Interface Tool, see the [Hewlett Packard Enterprise website](#).

Re-entering the server serial number and product ID

About this task

After you replace the system board, you must re-enter the system serial number and the product ID:

Procedure

1. During the system startup sequence, press the **F9** key to access UEFI System Utilities.
2. Select **System Configuration > BIOS/Platform Configuration (RBSU) > Advanced Options > Advanced System ROM Options > Serial Number**, and then press the **Enter** key.
3. Enter the serial number and press the **Enter** key.

The following message appears:

```
The serial number should only be modified by qualified service personnel.  
This value should always match the serial number located on the chassis.
```

4. To clear the warning, press the **Enter** key.
5. Enter the serial number and press the **Enter** key.
6. Select **Product ID**.

The following warning appears:

```
Warning: The Product ID should ONLY be modified by qualified service  
personnel. This value should always match the Product ID located on the  
chassis.
```

7. Enter the product ID and press the **Enter** key.
8. To confirm exiting System Utilities, press the **F10** key.

The system automatically reboots.

Troubleshooting

HPE Edgeline Troubleshooting Guide

The *HPE Edgeline System Troubleshooting Guide* provides procedures for resolving common problems and comprehensive courses of action for fault isolation and identification, issue resolution, and software maintenance on the Edgeline System. The document is available in the **Hewlett Packard Enterprise Information Library**.

Battery

Battery specifications

Feature	Specification
Type	Maintenance-free, sealed, CR2032 lithium manganese dioxide button battery
Voltage	3.0 V

Replace the system battery

Procedure

1. Locate the battery on the system board:
 - **System board components (PCIe)** on page 8
 - **System board components (PXIe)** on page 12
2. Slightly push the metal tab, and then use the small flat-nose pliers to remove the system battery from its socket.

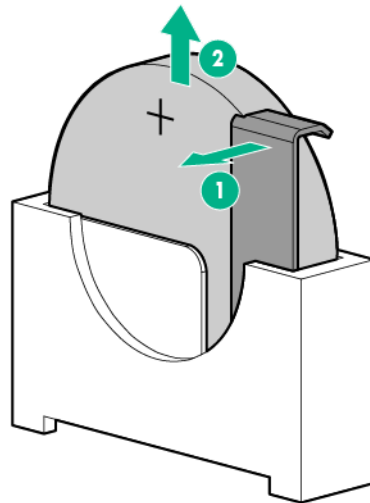

3. Slightly push the metal tab, then install the system battery in the socket.

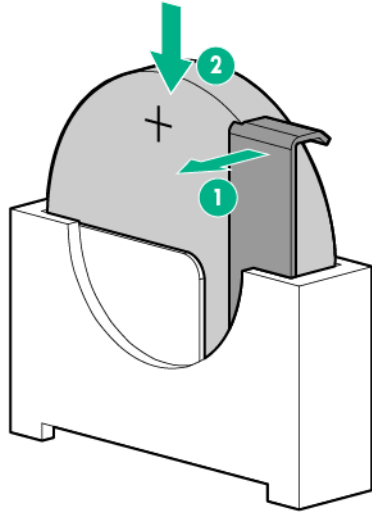

For more information about battery replacement or proper disposal, contact an authorized reseller or an authorized service provider.

Warranty and regulatory information

Warranty information

[HPE ProLiant and x86 Servers and Options](#)

[HPE Enterprise Servers](#)

[HPE Storage Products](#)

[HPE Networking Products](#)

Regulatory information

Safety and regulatory compliance

For important safety, environmental, and regulatory information, see *Safety and Compliance Information for Server, Storage, Power, Networking, and Rack Products*, available at the Hewlett Packard Enterprise website (<http://www.hpe.com/support/Safety-Compliance-EnterpriseProducts>).

Belarus Kazakhstan Russia marking



Manufacturer and Local Representative Information

Manufacturer information:

- Hewlett Packard Enterprise Company, 3000 Hanover Street, Palo Alto, CA 94304 U.S.

Local representative information Russian:

- Russia:

ООО «Хьюлетт Паккард Энтерпрайз», Российская Федерация, 125171, г. Москва, Ленинградское шоссе, 16А, стр.3, Телефон/факс: +7 495 797 35 00

- Belarus:

ИООО «Хьюлетт-Паккард Бел», Республика Беларусь, 220030, г. Минск, ул. Интернациональная, 36-1, Телефон/факс: +375 17 392 28 20

- Kazakhstan:

ТОО «Хьюлетт-Паккард (К)», Республика Казахстан, 050040, г. Алматы, Бостандыкский район, проспект Аль-Фараби, 77/7, Телефон/факс: + 7 727 355 35 52

Local representative information Kazakh:

- Russia:

ЖШС "Хьюлетт Паккард Энтерпрайз", Ресей Федерациясы, 125171, Мәскеу, Ленинград тас жолы, 16А блок 3, Телефон/факс: +7 495 797 35 00

- Belarus:

«HEWLETT-PACKARD Bel» ЖШС, Беларусь Республикасы, 220030, Минск қ.,
Интернациональная көшесі, 36/1, Телефон/факс: +375 17 392 28 20

- Kazakhstan:

ЖШС «Хьюлетт-Паккард (К)», Қазақстан Республикасы, 050040, Алматы қ.,
Бостандық ауданы, Әл-Фараби даңғылы, 77/7, Телефон/факс: +7 727 355 35 52

Manufacturing date:

The manufacturing date is defined by the serial number.

CCSYWWZZZZ (serial number format for this product)

Valid date formats include:

- YWW, where Y indicates the year counting from within each new decade, with 2000 as the starting point; for example, 238: 2 for 2002 and 38 for the week of September 9. In addition, 2010 is indicated by 0, 2011 by 1, 2012 by 2, 2013 by 3, and so forth.
- YYWW, where YY indicates the year, using a base year of 2000; for example, 0238: 02 for 2002 and 38 for the week of September 9.

Turkey RoHS material content declaration

Türkiye Cumhuriyeti: EEE Yönetmeliğine Uygundur

Ukraine RoHS material content declaration

Обладнання відповідає вимогам Технічного регламенту щодо обмеження використання деяких небезпечних речовин в електричному та електронному обладнанні, затвердженого постановою Кабінету Міністрів України від 3 грудня 2008 № 1057

Electrostatic discharge

Preventing electrostatic discharge

About this task

To prevent damaging the system, be aware of the precautions you must follow when setting up the system or handling parts. A discharge of static electricity from a finger or other conductor may damage system boards or other static-sensitive devices. This type of damage may reduce the life expectancy of the device.

Procedure

- Avoid hand contact by transporting and storing products in static-safe containers.
- Keep electrostatic-sensitive parts in their containers until they arrive at static-free workstations.
- Place parts on a grounded surface before removing them from their containers.
- Avoid touching pins, leads, or circuitry.
- Always be properly grounded when touching a static-sensitive component or assembly.

Grounding methods to prevent electrostatic discharge

Several methods are used for grounding. Use one or more of the following methods when handling or installing electrostatic-sensitive parts:

- Use a wrist strap connected by a ground cord to a grounded workstation or computer chassis. Wrist straps are flexible straps with a minimum of 1 megohm ± 10 percent resistance in the ground cords. To provide proper ground, wear the strap snug against the skin.
- Use heel straps, toe straps, or boot straps at standing workstations. Wear the straps on both feet when standing on conductive floors or dissipating floor mats.
- Use conductive field service tools.
- Use a portable field service kit with a folding static-dissipating work mat.

If you do not have any of the suggested equipment for proper grounding, have an authorized reseller install the part.

For more information on static electricity or assistance with product installation, contact an authorized reseller.

Specifications

Product QuickSpecs

For more information about product features, specifications, options, configurations, and compatibility, see the product QuickSpecs on the [Hewlett Packard Enterprise website](#).

Environmental specifications

Table 2: Standard specifications

Specification	Value
Temperature range¹	—
Operating	10°C to 35°C (50°F to 95°F)
Nonoperating	-30°C to 60°C (-22°F to 140°F)
Relative humidity (noncondensing)	—
Operating	8% to 90% at 28°C (82.4°F) maximum wet bulb temperature
Non-Operating	5% to 95% at 38.7°C (101.7°F) maximum wet bulb temperature

¹ All temperature ratings shown are for sea level. An altitude derating of 1.0°C per 304.8 m (1.8°F per 1,000 ft) to 3,048 m (10,000 ft) is applicable. No direct sunlight allowed. Maximum rate of change is 20°C per hour (36°F per hour).

Table 3: ASHRAE Class A3 specifications

Specification	Value
Temperature range¹	—
Operating	5°C to 40°C (41°F to 104°F)
Nonoperating	-30°C to 60°C (-22°F to 140°F)
Relative humidity (noncondensing)	—
Operating	8% to 90% at 28°C (82.4°F) maximum wet bulb temperature
Non-Operating	5% to 95% at 38.7°C (101.7°F) maximum wet bulb temperature

¹ All temperature ratings shown are for sea level. Good for 40°C operation up to 1,828 m (6,000 ft) with no altitude de-rating. No restriction on product configurations. Abnormal configurations, allowed for up to 96 hours at one time, no more than 15 days maximum per year. Operation above 40°C (104°F) up to 55°C (131°F), no altitude de-rating, 1,828 m (6,000 ft) limit. Some components could be outside the thermal maximum limits. System must be kept running, processor throttling is allowed. Abnormal conditions allow for operation down to -5°C (23°F).

Table 4: ASHRAE Class A4 specifications

Specification	Value
Temperature range¹	—
Operating	5°C to 45°C (41°F to 113°F)
Nonoperating	-30°C to 60°C (-22°F to 140°F)
Relative humidity (noncondensing)	—
Operating	8% to 90% at 28°C (82.4°F) maximum wet bulb temperature
Non-Operating	5% to 95% at 38.7°C (101.7°F) maximum wet bulb temperature

¹ All temperature ratings shown are for sea level. An altitude derating of 1.0°C per 125 m (1.8°F per 410 ft) to 900 m (2,953 ft) is applicable. No direct sunlight allowed. Maximum rate of change is 20°C per hour (36°F per hour). No restrictions on product configurations except for rotating hard drives. PCI cards must be rated for continuous operation with 60°C cooling air. Not rated for operation over 3,030 m (10,000 ft).

Table 5: Extended Edgeline specifications

Specification	Value
Temperature range¹	—
Operating	0°C to 55°C (32°F to 131°F)
Nonoperating	-30°C to 60°C (-22°F to 140°F)
Relative humidity (noncondensing)	—
Operating	8% to 90% at 28°C (82.4°F) maximum wet bulb temperature
Non-Operating	5% to 95% at 38.7°C (101.7°F) maximum wet bulb temperature

¹ All temperature ratings shown are for sea level. An altitude derating of 1.0°C per 304.8 m (1.8°F per 1,000 ft) to 3,048 m (10,000 ft) is applicable. No direct sunlight allowed. Maximum rate of change is 20°C per hour (36°F per hour).

Environmental specifications-system components support matrix

Environmental specification	Support status					
	Base system	Fans	SATA M.2 drives	NVME M.2 drives	PCIe cards	PXIe modules
Standard Operating Support	Yes	Yes (with redundancy)	Yes	Yes	Yes	Yes (up to 38 W) ¹
Extended Ambient 40°C Operating Support (ASHRAE Class A3 Compliant)	Yes	Yes (with redundancy)	Yes	Yes	Yes	Yes (up to 38 W) ¹

Table Continued

Environmental specification	Support status					
	Base system	Fans	SATA M.2 drives	NVME M.2 drives	PCIe cards	PXle modules
Extended Ambient 45°C Operating Support (ASHRAE Class A4 Compliant)	Yes	Yes (with redundancy) ²	Yes	Yes ³	Yes	No
Extended Edgeline 0°C to 55°C Operating Support	Yes ⁴	Yes (with redundancy) ²	Yes	No	Yes ⁵	No

¹ Maximum altitude is 2,000 m (800 mbar) (at 25 °C ambient temperature)

² Upon fan failure, the servers in the system might have reduced performance

³ M.2 drive might exceed its spec by 2°C to 3°C and have slight throttling.

⁴ Near 55°C inlet ambient temperature, when the CPU is stressed at 100%, the HPE m510 -16c server might have reduced performance.

⁵ The PCI card must have inlet spec rated at 65°C or higher, and an air speed of 375 ft/min.

Mechanical specifications

Specification	Value
Length	615 mm (24.21 in)
Width	435 mm (17.13 in)
Depth	43 mm (1.69 in)
Weight	14 kg (30.86 lb)

Power supply specifications

Depending on installed options, the system is configured with one of the following power supplies:

- **HPE 800W Flex Slot Platinum Hot Plug Power Supply** on page 47
- **HPE 800W Flex -48VDC Hot Plug Power Supply** on page 48

For detailed power supply specifications, see the QuickSpecs on the Hewlett Packard Enterprise website (<http://www.hpe.com/info/proliant/powersupply>).

HPE 800W Flex Slot Platinum Hot Plug Power Supply

Specification	Value							
Input voltage range (V rms)	100 to 240							
Frequency range (Nominal) (Hz)	50 to 60							
Nominal input voltage (V rms)	100	120	127	200	208	220	230	240
Maximum rated output wattage rating (Watts)	800	800	800	800	800	800	800	800

Table Continued

Nominal input current (A rms)	9.1	7.5	7.0	4.4	4.2	4.0	3.8	3.7
Maximum rated input wattage rating (Watts)	906	891	878	871	870	869	868	868
Maximum rated VA (Volt-Amp)	915	900	887	880	879	877	876	877
Efficiency (%)	88.3	89.8	91.1	91.9	92.0	92.1	92.2	92.1
Power factor	0.99	0.99	0.99	0.99	0.99	0.99	0.99	0.99
Leakage current (mA)	0.32	0.38	0.40	0.63	0.65	0.69	0.72	0.75
Maximum inrush current (A peak)	30	30	30	30	30	30	30	30
Maximum inrush current duration (ms)	10	10	10	10	10	10	10	10
Maximum British Thermal Unit rating (BTU-Hr)	3090	3040	2997	2972	2968	2963	2960	2963

HPE 800W Flex -48VDC Hot Plug Power Supply

Specification	Value		
Input voltage range (V DC)	-40 to -72		
Frequency range (Nominal) (Hz)	DC		
Nominal input voltage (V DC)	-40	-48	-72
Maximum rated output wattage rating (Watts)	800	800	800
Nominal input current (A DC)	22.0	18.1	11.9
Maximum rated input wattage rating (Watts)	882	871	858
Maximum rated VA (Volt-Amp)	882	871	858
Efficiency (%)	90.7	91.9	93.2
Power factor	1.0	1.0	1.0
Leakage current (mA)	0.0	0.0	0.0
Maximum inrush current (A peak)	30	30	30
Maximum inrush current duration (ms)	10	10	10
Maximum British Thermal Unit rating (BTU-Hr)	3008	2971	2929

PXI/PXle specifications

NOTE: Specifications are subject to change without notice.

Electrical load regulation specifications

Voltage (V)	Load regulation (%)
+3.3	<5
+12	<5

Chassis cooling specifications

Specification	Value
Module cooling system	Forced air circulation (positive pressurization) through seven fans with High/Auto speed selector.
Airflow	From front to rear

Pollution specifications

Specifications	Value
Pollution degree	2

For indoor use only in a climate-controlled environment.

Shock and vibration specifications

Specification	Value
Operational shock	30 g peak, half-sine, 11 ms pulse
Random vibration	5 Hz to 500 Hz, 0.3 g rms

Acoustic emission specifications

Acoustic noise

Acoustic noise specifications for the following base configurations are available.

Table 6: Base configuration 1 (m510)

Component	Quantity	Specification
Cartridge	4	m510
DIMMs/cartridge	4	Any
SATA M.2/cartridge	1	64 GB
NVME M.2/cartridge	0	NA
PXI	4	PXI 6341
PSU	2	800 W AC

Table 7: Base configuration 2 (m710x)

Component	Quantity	Specification
Cartridge	4	m710x
DIMMs/cartridge	4	Any
SATA M.2/cartridge	1	64 GB
NVME M.2/cartridge	0	NA
PXI	4	PXI 6341
PSU	2	800 W AC

The LWAd and LpAm when the system is operating in a 23°C ambient environment are provided in the following tables. Noise emissions were measured in accordance with ISO 7779 (ECMA 74) and declared in accordance with ISO 9296 (ECMA 109).

Table 8: Acoustic noise when system is idle

system configuration	LWAd (B)	LpAm (dBA)
Base 1	8	64.6
Base 2	8	64.6

Table 9: Acoustic noise when system is operating

system configuration	LWAd (B)	LpAm (dBA)
Base 1	8	64.6
Bae 2	8	64.6

NOTE:

If used in a manner not described in this document, the protection provided by the system can be impaired.

System synchronization clock specifications**10 MHz system reference clock: PXI_CLK10**

Specification	Value
Maximum slot-to-slot skew	1 ns
Accuracy	±25 ppm max (guaranteed over the operating temperature range)
Maximum jitter	5 ps RMS phase jitter (10 Hz to 1 MHz range)
Duty factor	45% to 55%
Unloaded signal swing	3.3 V ±0.3 V

NOTE:

For other specifications, see 'PXI-1 Hardware Specification' at the PXI Systems Alliance website (<http://www.pxisa.org/userfiles/files/Specifications/PXIHWSPEC22.pdf>).

100 MHz system reference clock: PXIe_CLK100 and PXIe_SYNC100

Specification	Value
Maximum slot-to-slot skew	200 ps
Accuracy	±25 ppm max (guaranteed over the operating temperature range)
Maximum jitter	5 ps RMS phase jitter (10 Hz to 12 kHz range); 5 ps RMS phase jitter (12 kHz to 20 MHz range)
Duty factor for PXIe_CLK100	45% to 55%
Absolute single-ended voltage swing (when each line in the differential pair has 50 W termination to 1.30 V or Thévenin equivalent)	400 mV to 1,000 mV

NOTE:

For other specifications, see 'PXI-5 PXI Express Hardware Specification' at the PXI Systems Alliance website (http://www.pxisa.org/userfiles/files/Specifications/PXIEXPRESS_HW_SPEC_R1.PDF).

External 10 MHz reference out (SMA on front panel of chassis)

Specification	Value
Accuracy	±25 ppm max (guaranteed over the operating temperature range)
Maximum jitter	5 ps RMS phase jitter (10 Hz to 1 MHz range)
Output amplitude	1 VPP ±20% square wave into 50 Ω 2 VPP unloaded
Output impedance	50 Ω ±5 Ω

External clock source

Specification	Value
Frequency	10 MHz ±100 PPM
Input amplitude	—
Front panel BNC	200 mVPP to 5 VPP square-wave or sine-wave
Front panel SMA input impedance	50 Ω ± 5 Ω

Websites

General websites

Hewlett Packard Enterprise Information Library

www.hpe.com/info/EIL

Single Point of Connectivity Knowledge (SPOCK) Storage compatibility matrix

www.hpe.com/storage/spock

Storage white papers and analyst reports

www.hpe.com/storage/whitepapers

For additional websites, see [Support and other resources](#).

Support and other resources

Accessing Hewlett Packard Enterprise Support

- For live assistance, go to the **Contact Hewlett Packard Enterprise Worldwide website**.
- To access documentation and support services, go to the **Hewlett Packard Enterprise Support Center website**.

Information to collect

- Technical support registration number (if applicable)
- Product name, model or version, and serial number
- Operating system name and version
- Firmware version
- Error messages
- Product-specific reports and logs
- Add-on products or components
- Third-party products or components

Accessing updates

- Some software products provide a mechanism for accessing software updates through the product interface. Review your product documentation to identify the recommended software update method.
- To download product updates:

Hewlett Packard Enterprise Support Center

www.hpe.com/support/hpesc

Hewlett Packard Enterprise Support Center: Software downloads

www.hpe.com/support/downloads

Software Depot

www.hpe.com/support/softwaredepot

- To subscribe to eNewsletters and alerts:

www.hpe.com/support/e-updates

- To view and update your entitlements, and to link your contracts and warranties with your profile, go to the Hewlett Packard Enterprise Support Center **More Information on Access to Support Materials** page:

www.hpe.com/support/AccessToSupportMaterials

IMPORTANT:

Access to some updates might require product entitlement when accessed through the Hewlett Packard Enterprise Support Center. You must have an HPE Passport set up with relevant entitlements.

Customer self repair

Hewlett Packard Enterprise customer self repair (CSR) programs allow you to repair your product. If a CSR part needs to be replaced, it will be shipped directly to you so that you can install it at your convenience. Some parts do not qualify for CSR. Your Hewlett Packard Enterprise authorized service provider will determine whether a repair can be accomplished by CSR.

For more information about CSR, contact your local service provider or go to the CSR website:

<http://www.hpe.com/support/selfrepair>

Remote support

Remote support is available with supported devices as part of your warranty or contractual support agreement. It provides intelligent event diagnosis, and automatic, secure submission of hardware event notifications to Hewlett Packard Enterprise, which will initiate a fast and accurate resolution based on your product's service level. Hewlett Packard Enterprise strongly recommends that you register your device for remote support.

If your product includes additional remote support details, use search to locate that information.

Remote support and Proactive Care information

HPE Get Connected

HPE Proactive Care services

HPE Proactive Care service: Supported products list

HPE Proactive Care advanced service: Supported products list

Proactive Care customer information

Proactive Care central

Proactive Care service activation

Acronyms and abbreviations

CM

chassis management

EMC

Electromagnetic compatibility

iLO

Integrated Lights-Out

LpAm

declared average bystander position A-Weighted sound pressure levels

LTE

long-term evolution

LWAd

declared A-Weighted sound power levels

PCI

peripheral component interconnect

PCIe

Peripheral Component Interconnect Express

PXE

preboot execution environment

PXI

PCI eXtensions for instrumentation

PXIe

PCI eXtensions for instrumentation express

QSFP+

enhanced quad small form-factor pluggable

SFP+

enhanced small form-factor pluggable

UEFI

Unified Extensible Firmware Interface

UID

unit identification

WiFi

wireless fidelity

WLAN

wireless local area network

WWAN

wireless wide area network

Documentation feedback

Hewlett Packard Enterprise is committed to providing documentation that meets your needs. To help us improve the documentation, send any errors, suggestions, or comments to Documentation Feedback (docsfeedback@hpe.com). When submitting your feedback, include the document title, part number, edition, and publication date located on the front cover of the document. For online help content, include the product name, product version, help edition, and publication date located on the legal notices page.