

## COMPREHENSIVE SERVICES

We offer competitive repair and calibration services, as well as easily accessible documentation and free downloadable resources.

## SELL YOUR SURPLUS

We buy new, used, decommissioned, and surplus parts from every NI series. We work out the best solution to suit your individual needs.

 Sell For Cash    Get Credit    Receive a Trade-In Deal

## OBSOLETE NI HARDWARE IN STOCK & READY TO SHIP

We stock **New**, **New Surplus**, **Refurbished**, and **Reconditioned** NI Hardware.



*Bridging the gap between the manufacturer and your legacy test system.*

 1-800-915-6216

 [www.apexwaves.com](http://www.apexwaves.com)

 [sales@apexwaves.com](mailto:sales@apexwaves.com)

*All trademarks, brands, and brand names are the property of their respective owners.*

**Request a Quote**

 **CLICK HERE**

**GPIB-PCII**

**DAQ**

# **AT-MIO-16X User Manual**

*Multifunction I/O Board for the PC AT/EISA*

October 1997 Edition  
Part Number 320640B-01



### **Internet Support**

support@natinst.com

E-mail: info@natinst.com

FTP Site: ftp.natinst.com

Web Address: <http://www.natinst.com>



### **Bulletin Board Support**

BBS United States: (512) 794-5422

BBS United Kingdom: 01635 551422

BBS France: 01 48 65 15 59



### **Fax-on-Demand Support**

(512) 418-1111

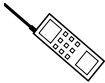

### **Telephone Support (U.S.)**

Tel: (512) 795-8248

Fax: (512) 794-5678

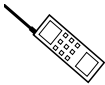

### **International Offices**

Australia 03 9879 5166, Austria 0662 45 79 90 0, Belgium 02 757 00 20,  
Canada (Ontario) 905 785 0085, Canada (Québec) 514 694 8521, Denmark 45 76 26 00,  
Finland 09 725 725 11, France 01 48 14 24 24, Germany 089 741 31 30,  
Hong Kong 2645 3186, Israel 03 5734815, Italy 02 413091, Japan 03 5472 2970,  
Korea 02 596 7456, Mexico 5 520 2635, Netherlands 0348 433466, Norway 32 84 84 00,  
Singapore 2265886, Spain 91 640 0085, Sweden 08 730 49 70, Switzerland 056 200 51 51,  
Taiwan 02 377 1200, United Kingdom 01635 523545

### **National Instruments Corporate Headquarters**

6504 Bridge Point Parkway Austin, TX 78730-5039 Tel: (512) 794-0100

# Important Information

---

## Warranty

The AT-MIO-16X is warranted against defects in materials and workmanship for a period of one year from the date of shipment, as evidenced by receipts or other documentation. National Instruments will, at its option, repair or replace equipment that proves to be defective during the warranty period. This warranty includes parts and labor.

The media on which you receive National Instruments software are warranted not to fail to execute programming instructions, due to defects in materials and workmanship, for a period of 90 days from date of shipment, as evidenced by receipts or other documentation. National Instruments will, at its option, repair or replace software media that do not execute programming instructions if National Instruments receives notice of such defects during the warranty period. National Instruments does not warrant that the operation of the software shall be uninterrupted or error free.

A Return Material Authorization (RMA) number must be obtained from the factory and clearly marked on the outside of the package before any equipment will be accepted for warranty work. National Instruments will pay the shipping costs of returning to the owner parts which are covered by warranty.

National Instruments believes that the information in this manual is accurate. The document has been carefully reviewed for technical accuracy. In the event that technical or typographical errors exist, National Instruments reserves the right to make changes to subsequent editions of this document without prior notice to holders of this edition. The reader should consult National Instruments if errors are suspected. In no event shall National Instruments be liable for any damages arising out of or related to this document or the information contained in it.

EXCEPT AS SPECIFIED HEREIN, NATIONAL INSTRUMENTS MAKES NO WARRANTIES, EXPRESS OR IMPLIED, AND SPECIFICALLY DISCLAIMS ANY WARRANTY OF MERCHANTABILITY OR FITNESS FOR A PARTICULAR PURPOSE. CUSTOMER'S RIGHT TO RECOVER DAMAGES CAUSED BY FAULT OR NEGLIGENCE ON THE PART OF NATIONAL INSTRUMENTS SHALL BE LIMITED TO THE AMOUNT THERETOFORE PAID BY THE CUSTOMER. NATIONAL INSTRUMENTS WILL NOT BE LIABLE FOR DAMAGES RESULTING FROM LOSS OF DATA, PROFITS, USE OF PRODUCTS, OR INCIDENTAL OR CONSEQUENTIAL DAMAGES, EVEN IF ADVISED OF THE POSSIBILITY THEREOF. This limitation of the liability of National Instruments will apply regardless of the form of action, whether in contract or tort, including negligence. Any action against National Instruments must be brought within one year after the cause of action accrues. National Instruments shall not be liable for any delay in performance due to causes beyond its reasonable control. The warranty provided herein does not cover damages, defects, malfunctions, or service failures caused by owner's failure to follow the National Instruments installation, operation, or maintenance instructions; owner's modification of the product; owner's abuse, misuse, or negligent acts; and power failure or surges, fire, flood, accident, actions of third parties, or other events outside reasonable control.

## Copyright

Under the copyright laws, this publication may not be reproduced or transmitted in any form, electronic or mechanical, including photocopying, recording, storing in an information retrieval system, or translating, in whole or in part, without the prior written consent of National Instruments Corporation.

## Trademarks

ComponentWorks™, LabVIEW™, Measure™, NI-DAQ™, RTSI™, and VirtualBench™ are trademarks of National Instruments Corporation.

Product and company names listed are trademarks or trade names of their respective companies.

## WARNING REGARDING MEDICAL AND CLINICAL USE OF NATIONAL INSTRUMENTS PRODUCTS

National Instruments products are not designed with components and testing intended to ensure a level of reliability suitable for use in treatment and diagnosis of humans. Applications of National Instruments products involving medical or clinical treatment can create a potential for accidental injury caused by product failure, or by errors on the part of the user or application designer. Any use or application of National Instruments products for or involving medical or clinical treatment must be performed by properly trained and qualified medical personnel, and all traditional medical safeguards, equipment, and procedures that are appropriate in the particular situation to prevent serious injury or death should always continue to be used when National Instruments products are being used. National Instruments products are NOT intended to be a substitute for any form of established process, procedure, or equipment used to monitor or safeguard human health and safety in medical or clinical treatment.



*Table  
of  
Contents*

---

## About This Manual

Organization of This Manual .....	xv
Conventions Used in This Manual .....	xvi
Related Documentation .....	xvii
Customer Communication .....	xvii

## Chapter 1 Introduction

About the AT-MIO-16X .....	1-1
Analog Input .....	1-2
Analog Output .....	1-2
Digital and Timing I/O .....	1-3
What You Need to Get Started .....	1-3
Software Programming Choices .....	1-4
National Instruments Application Software .....	1-4
NI-DAQ Driver Software .....	1-5
Register-Level Programming .....	1-6
Optional Equipment .....	1-7
Unpacking .....	1-7

## Chapter 2 Configuration and Installation

Board Configuration .....	2-2
AT Bus Interface .....	2-2
Base I/O Address Selection .....	2-3
Interrupt and DMA Channel Selection .....	2-7
Analog Input Configuration .....	2-7
Input Mode .....	2-7
DIFF Input (Eight Channels) .....	2-8
RSE Input (16 Channels) .....	2-9
NRSE Input (16 Channels) .....	2-9
Input Polarity and Input Range .....	2-10
Considerations for Selecting Input Ranges .....	2-10
Analog Output Configuration .....	2-11

Analog Output Reference Selection.....	2-11
Analog Output Polarity Selection .....	2-12
Digital I/O Configuration .....	2-12
Board and RTSI Clock Configuration.....	2-12
Hardware Installation .....	2-13
Signal Connections.....	2-14
Signal Connection Descriptions.....	2-17
Analog Input Signal Connections .....	2-19
Types of Signal Sources.....	2-21
Floating Signal Sources .....	2-21
Ground-Referenced Signal Sources.....	2-21
Input Configurations .....	2-21
Differential Connection Considerations (DIFF Input	
Configuration).....	2-22
Differential Connections for Ground-Referenced Signal	
Sources.....	2-23
Differential Connections for Nonreferenced or Floating	
Signal Sources .....	2-24
Single-Ended Connection Considerations .....	2-26
Single-Ended Connections for Floating Signal Sources	
(RSE Configuration).....	2-27
Single-Ended Connections for Grounded Signal Sources	
(NRSE Configuration).....	2-28
Common-Mode Signal Rejection Considerations .....	2-29
Analog Output Signal Connections.....	2-29
Digital I/O Signal Connections .....	2-31
Power Connections .....	2-32
Timing Connections for Data Acquisition and Analog Output .....	2-33
SCANCLK Signal .....	2-33
EXTSTROBE* Signal.....	2-33
EXTCONV* Signal.....	2-34
EXTTRIG* Signal.....	2-35
EXTGATE* Signal.....	2-36
EXTTMRTRIG* Signal .....	2-36
Counter Signal Connections .....	2-37
Field Wiring Considerations.....	2-42
Cabling Considerations for the AT-MIO-16X with 50-Pin I/O Connector .....	2-43
Cabling Considerations for the AT-MIO-16X with 68-Pin I/O Connector .....	2-44

## Chapter 3

### Theory of Operation

Functional Overview .....	3-1
PC I/O Channel Interface Circuitry .....	3-2
Analog Input and Data Acquisition Circuitry .....	3-5
Analog Input Circuitry .....	3-6
A/D Converter .....	3-6
Analog Input Multiplexers .....	3-6
Analog Input Configuration .....	3-6
PGIA .....	3-7
ADC FIFO Buffer .....	3-7
Analog Input Calibration .....	3-7
Data Acquisition Timing Circuitry .....	3-8
Single-Read Timing .....	3-8
Single-Channel Data Acquisition Timing .....	3-9
Multiple-Channel Data Acquisition .....	3-12
Continuous Scanning Data Acquisition Timing .....	3-13
Interval Scanning Data Acquisition Timing .....	3-14
Data Acquisition Rates .....	3-15
Analog Output and Timing Circuitry .....	3-15
Analog Output Circuitry .....	3-16
Analog Output Configuration .....	3-17
Analog Output Calibration .....	3-17
DAC Waveform Circuitry and Timing .....	3-18
DAC Waveform Circuitry .....	3-18
DAC Waveform Timing Circuitry .....	3-20
FIFO Continuous Cyclic Waveform Generation .....	3-22
FIFO Programmed Cyclic Waveform Generation .....	3-23
FIFO Pulsed Waveform Generation .....	3-23
Digital I/O Circuitry .....	3-24
Timing I/O Circuitry .....	3-25
RTSI Bus Interface Circuitry .....	3-29

## Chapter 4

### Register Map and Descriptions

Register Map .....	4-1
Register Sizes .....	4-3
Register Description Format .....	4-3
Configuration and Status Register Group .....	4-4
Command Register 1 .....	4-5
Command Register 2 .....	4-9

Command Register 3 .....	4-13
Command Register 4 .....	4-20
Status Register 1 .....	4-25
Status Register 2 .....	4-30
Analog Input Register Group .....	4-31
ADC FIFO Register .....	4-32
CONFIGMEM Register .....	4-35
Analog Output Register Group .....	4-41
DAC0 Register .....	4-44
DAC1 Register .....	4-45
ADC Event Strobe Register Group .....	4-46
CONFIGMEMCLR Register .....	4-47
CONFIGMEMLD Register .....	4-48
DAQ Clear Register .....	4-49
DAQ Start Register .....	4-50
Single Conversion Register .....	4-51
ADC Calibration Register .....	4-52
DAC Event Strobe Register Group .....	4-53
TMRREQ Clear Register .....	4-54
DAC Update Register .....	4-55
DAC Clear Register .....	4-56
General Event Strobe Register Group .....	4-57
DMA Channel Clear Register .....	4-58
DMATCA Clear Register .....	4-59
DMATCB Clear Register .....	4-60
External Strobe Register .....	4-61
Calibration DAC 0 Load Register .....	4-62
Calibration DAC 1 Load Register .....	4-63
Am9513A Counter/Timer Register Group .....	4-64
Am9513A Data Register .....	4-65
Am9513A Command Register .....	4-66
Am9513A Status Register .....	4-67
Digital I/O Register Group .....	4-68
Digital Input Register .....	4-69
Digital Output Register .....	4-70
RTSI Switch Register Group .....	4-71
RTSI Switch Shift Register .....	4-72
RTSI Switch Strobe Register .....	4-73



## Chapter 5

### Programming

Register Programming Considerations.....	5-1
Resource Allocation Considerations .....	5-1
Initializing the AT-MIO-16X .....	5-2
Initializing the Am9513A .....	5-3
Programming the Analog Input Circuitry.....	5-5
Single Conversions Using the SCONVERT or EXTCONV* Signal .....	5-5
Generating a Single Conversion .....	5-6
Reading a Single Conversion Result .....	5-7
Programming Single-Channel Data Acquisition Sequence.....	5-7
Programming Data Acquisition Sequences with Channel Scanning.....	5-10
Continuous Channel Scanning Data Acquisition.....	5-10
Interval-Channel Scanning Data Acquisition.....	5-12
Data Acquisition Programming Functions .....	5-14
Clearing the Analog Input Circuitry .....	5-14
Programming Single-Analog Input Channel Configurations .....	5-15
Programming Multiple-Analog Input Channel Configurations .....	5-15
Programming the Sample-Interval Counter.....	5-16
Programming the Sample Counter(s).....	5-17
Sample Counts 2 through 65,536.....	5-18
Sample Counts Greater than 65,536 .....	5-18
Programming the Scan-Interval Counter.....	5-20
Applying a Trigger .....	5-21
Servicing the Data Acquisition Operation.....	5-22
Resetting the Hardware after a Data Acquisition Operation .....	5-22
Resetting a Single Am9513A Counter/Timer.....	5-23
Programming the Analog Output Circuitry .....	5-25
Cyclic Waveform Generation.....	5-26
Programmed Cycle Waveform Generation .....	5-28
Pulsed Cyclic Waveform Generation .....	5-30
Waveform Generation Programming Functions .....	5-32
Clearing the Analog Output Circuitry.....	5-32
Selecting the Internal Update Counter .....	5-32
Programming the Update-Interval Counter .....	5-32
Programming the Waveform Cycle Counter.....	5-34
Programming the Waveform Cycle Interval Counter .....	5-34
Servicing Update Requests .....	5-35
Programming the Digital I/O Circuitry.....	5-36
Programming the Am9513A Counter/Timer.....	5-37
RTSI Bus Trigger Line Programming Considerations .....	5-37

RTSI Switch Signal Connection Considerations.....	5-38
Programming the RTSI Switch .....	5-39
Programming DMA Operations.....	5-41
Interrupt Programming.....	5-43

## **Chapter 6**

### **Calibration Procedures**

Calibration Equipment Requirements .....	6-7
Calibration DACs .....	6-8
Reference Calibration .....	6-8
Analog Input Calibration .....	6-9
Analog Output Calibration .....	6-10

## **Appendix A**

### **Specifications**

## **Appendix B**

### **I/O Connector**

## **Appendix C**

### **AMD Am9513A Data Sheet**

## **Appendix D**

### **Customer Communication**

## **Glossary**

## **Index**

## **Figures**

Figure 1-1. The Relationship between the Programming Environment, NI-DAQ, and Your Hardware .....	1-6
Figure 2-1. AT-MIO-16X with 50-Pin I/O Connector Parts Locator Diagram .....	2-1
Figure 2-2. AT-MIO-16X with 68-Pin I/O Connector Parts Locator Diagram .....	2-2
Figure 2-3. Example Base I/O Address Switch Settings.....	2-3
Figure 2-4. AT-MIO-16X 50-Pin I/O Connector.....	2-15

Figure 2-5.	AT-MIO-16X 68-Pin I/O Connector .....	2-16
Figure 2-6.	AT-MIO-16X PGIA .....	2-20
Figure 2-7.	Differential Input Connections for Ground-Referenced Signals .....	2-23
Figure 2-8.	Differential Input Connections for Nonreferenced Signals .....	2-24
Figure 2-9.	Single-Ended Input Connections for Nonreferenced or Floating Signals .....	2-27
Figure 2-10.	Single-Ended Input Connections for Ground-Referenced Signals .....	2-28
Figure 2-11.	Analog Output Connections.....	2-30
Figure 2-12.	Digital I/O Connections.....	2-32
Figure 2-13.	EXTSTROBE* Signal Timing .....	2-33
Figure 2-14.	EXTCONV* Signal Timing .....	2-34
Figure 2-15.	EXTTRIG* Signal Timing .....	2-35
Figure 2-16.	EXTTMRTRIG* Signal Timing.....	2-36
Figure 2-17.	Event-Counting Application with External Switch Gating .....	2-38
Figure 2-18.	Frequency Measurement Application .....	2-39
Figure 2-19.	General-Purpose Timing Signals .....	2-41
Figure 3-1.	AT-MIO-16X Block Diagram .....	3-1
Figure 3-2.	PC I/O Channel Interface Circuitry Block Diagram.....	3-3
Figure 3-3.	Analog Input and Data Acquisition Circuitry Block Diagram .....	3-5
Figure 3-4.	ADC Conversion Timing.....	3-8
Figure 3-5.	Single-Channel Posttrigger Data Acquisition Timing .....	3-10
Figure 3-6.	Single-Channel Pretrigger Data Acquisition Timing.....	3-11
Figure 3-7.	Scanning Posttrigger Data Acquisition Timing .....	3-13
Figure 3-8.	Interval Scanning Posttrigger Data Acquisition Timing.....	3-14
Figure 3-9.	Analog Output Circuitry Block Diagram.....	3-16
Figure 3-10.	Analog Output Waveform Circuitry .....	3-19
Figure 3-11.	Posted DAC Update Timing .....	3-20
Figure 3-12.	Analog Output Waveform Circuitry .....	3-21
Figure 3-13.	FIFO Cyclic Waveform Generation with Disable .....	3-22
Figure 3-14.	FIFO Programmed Cyclic Waveform Timing.....	3-23
Figure 3-15.	FIFO Pulsed Waveform Generation Timing .....	3-23
Figure 3-16.	Digital I/O Circuitry Block Diagram .....	3-24
Figure 3-17.	Timing I/O Circuitry Block Diagram .....	3-26
Figure 3-18.	Counter Block Diagram.....	3-27
Figure 3-19.	RTSI Bus Interface Circuitry Block Diagram .....	3-29
Figure 5-1.	Initializing the Am9513A Counter/Timer .....	5-4
Figure 5-2.	Single Conversion Programming.....	5-6
Figure 5-3.	Single-Channel Data Acquisition Programming .....	5-9
Figure 5-4.	Scanning Data Acquisition Programming .....	5-11
Figure 5-5.	Interval Scanning Data Acquisition Programming .....	5-13
Figure 5-6.	Resetting an Am9513A Counter/Timer .....	5-24

Figure 5-7.	Cyclic Waveform Programming .....	5-27
Figure 5-8.	Programmed Cycle Waveform Programming .....	5-29
Figure 5-9.	Pulsed Cyclic Waveform Programming .....	5-31
Figure 5-10.	RTSI Switch Control Pattern.....	5-40
Figure 6-1.	AT-MIO-16X EEPROM Map.....	6-2
Figure 6-2.	Revision and Subrevision Field.....	6-5
Figure 6-3.	Configuration Memory Depth Field.....	6-5
Figure 6-4.	ADC and DAC FIFO Depth Field.....	6-6
Figure 6-5.	Area Information Field.....	6-6
Figure B-1.	AT-MIO-16X 50-Pin I/O Connector.....	B-2
Figure B-2.	AT-MIO-16X 68-Pin I/O Connector.....	B-3

## Tables

Table 2-1.	Default Settings of National Instruments Products for the PC.....	2-4
Table 2-2.	Switch Settings with Corresponding Base I/O Address and Base I/O Address Space .....	2-5
Table 2-3.	Available Input Configurations for the AT-MIO-16X.....	2-8
Table 2-4.	Actual Range and Measurement Precision Versus Input Range Selection and Gain.....	2-11
Table 2-5.	Recommended Input Configurations for Ground-Referenced and Floating Signal Sources.....	2-22
Table 4-1.	AT-MIO-16X Register Map.....	4-1
Table 4-2.	DMA Channel Selection .....	4-12
Table 4-3.	DMA and Interrupt Modes .....	4-16
Table 4-4.	Interrupt Level Selection .....	4-19
Table 4-5.	Board and RTSI Clock Selection .....	4-21
Table 4-6.	Analog Output Waveform Modes .....	4-22
Table 4-7.	Straight Binary Mode A/D Conversion Values.....	4-33
Table 4-8.	Two's Complement Mode A/D Conversion Values .....	4-34
Table 4-9.	Input Configuration .....	4-39
Table 4-10.	Analog Output Voltage Versus Digital Code (Unipolar Mode).....	4-42
Table 4-11.	Analog Output Voltage Versus Digital Code (Bipolar Mode).....	4-42
Table 5-1.	Am9513A Counter/Timer Allocations.....	5-2
Table 5-2.	RTSI Switch Signal Connections .....	5-38
Table 6-1.	EEPROM Factory Area Information.....	6-2
Table 6-2.	Calibration DACs .....	6-8

Table A-1.	Equivalent Offset Errors in 16-Bit Systems .....	A-3
Table A-2.	Equivalent Gain Errors in 16-Bit Systems.....	A-4
Table A-3.	Typical Multiple-Channel Scanning Settling Times .....	A-5
Table B-1.	Signal Connection Descriptions.....	B-4

This manual describes the mechanical and electrical aspects of the AT-MIO-16X board and contains information concerning its operation and programming. The AT-MIO-16X is a high-performance, multifunction analog, digital, and timing I/O board for the IBM PC AT and compatibles and EISA personal computers (PCs).

## Organization of This Manual

---

The *AT-MIO-16X User Manual* is organized as follows:

- Chapter 1, *Introduction*, describes the AT-MIO-16X, lists the contents of your AT-MIO-16X kit, the optional software, and optional equipment, and explains how to unpack the AT-MIO-16X.
- Chapter 2, *Configuration and Installation*, explains board configuration, installation of the AT-MIO-16X into the PC, signal connections to the AT-MIO-16X, and cable considerations.
- Chapter 3, *Theory of Operation*, contains a functional overview of the AT-MIO-16X and explains the operation of each functional unit making up the AT-MIO-16X.
- Chapter 4, *Register Map and Descriptions*, describes in detail the address and function of each of the AT-MIO-16X control and status registers.
- Chapter 5, *Programming*, contains programming instructions for operating the circuitry on the AT-MIO-16X.
- Chapter 6, *Calibration Procedures*, discusses the calibration resources and procedures for the AT-MIO-16X analog input and analog output circuitry.
- Appendix A, *Specifications*, lists the specifications of the AT-MIO-16X.
- Appendix B, *I/O Connector*, describes the pinout and signal names for the AT-MIO-16X 50-pin I/O connector and the 68-pin I/O connector.

- Appendix C, *AMD Am9513A Data Sheet*, contains the manufacturer data sheet for the AMD Am9513A System Timing Controller integrated circuit (Advanced Micro Devices, Inc.). This controller is used on the AT-MIO-16X.
- Appendix D, *Customer Communication*, contains forms you can use to request help from National Instruments or to comment on our products.
- The *Glossary* contains an alphabetical list and description of terms used in this manual, including abbreviations, acronyms, metric prefixes, mnemonics, and symbols.
- The *Index* contains an alphabetical list of key terms and topics used in this manual, including the page where you can find each one.

## Conventions Used in This Manual

---

The following conventions are used in this manual:

< >

Angle brackets containing numbers separated by an ellipsis represent a range of values associated with a bit or signal name (for example, DBIO<3..0>).



This icon to the left of bold italicized text denotes a note, which alerts you to important information.



This icon to the left of bold italicized text denotes a caution, which advises you of precautions to take to avoid injury, data loss, or a system crash.

***bold italic***

Bold italic text denotes a note, caution, or warning.

*italic*

Italic text denotes emphasis, a cross reference, or an introduction to a key concept.

NI-DAQ

NI-DAQ is used throughout this manual to refer to the NI-DAQ software for DOS/Windows/LabWindows unless otherwise noted.

PC

PC refers to the IBM PC AT and compatibles, and to EISA personal computers.

The *Glossary* lists abbreviations, acronyms, metric prefixes, mnemonics, symbols, and terms.

## Related Documentation

---

The following document contains information that you may find helpful as you read this manual:

- *IBM Personal Computer AT Technical Reference*

You may also want to consult the following Advanced Micro Devices information if you plan to program the Am9513A Counter/Timer used on the AT-MIO-16X:

- *Am9513A/Am9513 System Timing Controller*

## Customer Communication

---

National Instruments want to receive your comments on our products and manuals. We are interested in the applications you develop with our products, and we want to help if you have problems with them. To make it easy for you to contact us, this manual contains comment and configuration forms for you to complete. These forms are in Appendix D, *Customer Communication*, at the end of this manual.



# Introduction

---

Chapter

1

This chapter describes the AT-MIO-16X, lists the contents of your AT-MIO-16X kit, the optional software, and optional equipment, and explains how to unpack the AT-MIO-16X.

## About the AT-MIO-16X

---

Congratulations on your purchase of the National Instruments AT-MIO-16X. The AT-MIO-16X is a high-performance, software-configurable 16-bit DAQ board for laboratory, test and measurement, and data acquisition and control applications. The board performs *high-accuracy* measurements with self-calibration, high-speed settling to 16 bits, noise as low as 0.8 LSB<sub>rms</sub>, and a maximum DNL of  $\pm 0.5$  LSB. Because of its large FIFOs and dual-channel DMA, the AT-MIO-16X can achieve *high performance*, even when used in environments that may have long interrupt latencies, such as Windows.

Because off-the-shelf instrumentation amplifiers require 500  $\mu$ sec and more to settle to 16-bit accuracy at high gains when sampling multiple channels, National Instruments developed the *NI-PGIA*. The NI-PGIA, which is used on the AT-MIO-16X, is an instrumentation amplifier that settles to 16 bits in 40  $\mu$ s, even when the board is used at its highest gain of 100.

A common problem with DAQ boards is that you cannot easily synchronize several measurement functions to a common trigger or timing event. The AT-MIO-16X has the Real-Time System Integration (RTSI) bus to solve this problem. The *RTSibus* consists of our custom RTSI bus interface chip and a ribbon cable to route timing and trigger signals between several functions on one or more DAQ boards in your PC.

The AT-MIO-16X can interface to the Signal Conditioning eXtensions for Instrumentation (*SCXI*) system so that you can acquire over 3,000 analog signals from thermocouples, RTDs, strain gauges, voltage sources, and current sources. You can also acquire or generate digital

signals for communication and control. SCXI is the instrumentation front end for plug-in DAQ boards.

## Analog Input

The AT-MIO-16X is a high-performance multifunction analog, digital, and timing I/O board for the PC. The AT-MIO-16X has a 10  $\mu$ sec, 16-bit, sampling ADC that can monitor a single input channel, or scan through the 16 single-ended or 8 differential channels (expandable with National Instruments multiplexing products) at a programmable gain of 1, 2, 5, 10, 20, 50, or 100 for unipolar or bipolar input ranges. A 512-word ADC FIFO buffer can perform seamless data acquisition at the maximum rate without data loss. Internal or external triggering and sampling are supported. If signal conditioning or additional analog inputs are required, you can use the SCXI signal conditioning modules, SCXI multiplexer products, or the AMUX-64T multiplexer board.

You can use the NI-DAQ software included with the AT-MIO-16X to calibrate the analog input circuitry. This software adjusts the offset and gain errors to zero by means of board-level calibration DACs. You can store calibration DAC constants resulting from the calibration procedure in the onboard EEPROM for later use. See Chapter 6, *Calibration Procedures*, for additional information on calibration procedures for the AT-MIO-16X.

## Analog Output

The AT-MIO-16X also has two deglitched, double-buffered, multiplying, 16-bit DACs that may be configured for a unipolar or bipolar voltage output range. An onboard, +10-V reference is the internal reference to the circuitry of the DAC. A 2,048-word DAC FIFO buffer allows seamless waveform generation at the maximum rate without data loss. The DAC FIFO can perform cyclic waveform generation directly from the FIFO, independent of the PC interface. You can use the analog output circuitry for internal timer and external signal update capability for waveform generation.

You calibrate the analog output circuitry through the NI-DAQ software provided with the board. This software adjusts the DAC offset and gain errors of each channel to zero by means of board-level calibration DACs. Calibration DAC constants resulting from the calibration procedure may be stored in the onboard EEPROM for later use. See Chapter 6, *Calibration Procedures*, for additional information on calibration procedures for the AT-MIO-16X.

## Digital and Timing I/O

In addition to the analog input and analog output capabilities of the AT-MIO-16X, the AT-MIO-16X also has eight digital I/O lines that can sink up to 24 mA of current, and three independent 16-bit counter/timers for frequency counting, event counting, and pulse output applications. The AT-MIO-16X has timer-generated interrupts, a high-performance RTSI bus interface, and four triggers for system-level timing.

You can use the AT-MIO-16X, with its multifunction analog, digital, and timing I/O, in many applications, including machine and process control automation, level monitoring and control, instrumentation, electronic testing, and many others. You can use the multichannel analog input for signal and transient analysis, data logging, and chromatography. The two analog output channels are useful for machine and process control, analog function generation, 16-bit resolution voltage source, and programmable signal attenuation. You can use the eight TTL-compatible digital I/O lines for machine and process control, intermachine communication, and relay switching control. The three 16-bit counter/timers are useful for such functions as pulse and clock generation, timed control of laboratory equipment, and frequency, event, and pulse-width measurement. With all these functions on one board, you can automatically monitor and control laboratory processes.

The AT-MIO-16X is interfaced to the National Instruments RTSI bus. With this bus, National Instruments AT Series boards can send timing signals to each other. The AT-MIO-16X can send signals from the onboard counter/timer to another board, or another board can control single and multiple A/D conversions on the AT-MIO-16X.

Detailed specifications for the AT-MIO-16X are listed in Appendix A, *Specifications*.

## What You Need to Get Started

---

To set up and use your AT-MIO-16X Series board, you will need the following:

- One of the following boards:
  - AT-MIO-16X 50-pin
  - AT-MIO-16X 68-pin

- AT-MIO-16X User Manual*
- One of the following software packages and documentation:
  - ComponentWorks
  - LabVIEW for Windows
  - LabWindows/CVI for Windows
  - Measure
  - NI-DAQ for PC Compatibles
  - VirtualBench
- Your computer

## Software Programming Choices

---

You have several options to choose from when programming your National Instruments DAQ and SCXI hardware. You can use National Instruments application software, NI-DAQ, or register-level programming.

### National Instruments Application Software

ComponentWorks contains tools for data acquisition and instrument control built on NI-DAQ driver software. ComponentWorks provides a higher-level programming interface for building virtual instruments through standard OLE controls and DLLs. With ComponentWorks, you can use all of the configuration tools, resource management utilities, and interactive control utilities included with NI-DAQ.

LabVIEW features interactive graphics, a state-of-the-art user interface, and a powerful graphical programming language. The LabVIEW Data Acquisition VI Library, a series of VIs for using LabVIEW with National Instruments DAQ hardware, is included with LabVIEW. The LabVIEW Data Acquisition VI Library is functionally equivalent to NI-DAQ software.

LabWindows/CVI features interactive graphics, state-of-the-art user interface, and uses the ANSI standard C programming language. The LabWindows/CVI Data Acquisition Library, a series of functions for using LabWindows/CVI with National Instruments DAQ hardware, is included with the NI-DAQ software kit. The LabWindows/CVI Data Acquisition Library is functionally equivalent to the NI-DAQ software.

VirtualBench features virtual instruments that combine DAQ products, software, and your computer to create a stand-alone instrument with the added benefit of the processing, display, and storage capabilities of your computer. VirtualBench instruments load and save waveform data to disk in the same forms that can be used in popular spreadsheet programs and word processors.

Using ComponentWorks, LabVIEW, LabWindows/CVI, or VirtualBench software will greatly reduce the development time for your data acquisition and control application.

## NI-DAQ Driver Software

The NI-DAQ driver software is included at no charge with all National Instruments DAQ hardware. NI-DAQ is not packaged with SCXI or accessory products, except for the SCXI-1200. NI-DAQ has an extensive library of functions that you can call from your application programming environment. These functions include routines for analog input (A/D conversion), buffered data acquisition (high-speed A/D conversion), analog output (D/A conversion), waveform generation (timed D/A conversion), digital I/O, counter/timer operations, SCXI, RTSI, self-calibration, messaging, and acquiring data to extended memory.

NI-DAQ has both high-level DAQ I/O functions for maximum ease of use and low-level DAQ I/O functions for maximum flexibility and performance. Examples of high-level functions are streaming data to disk or acquiring a certain number of data points. An example of a low-level function is writing directly to registers on the DAQ device. NI-DAQ does not sacrifice the performance of National Instruments DAQ devices because it lets multiple devices operate at their peak.

NI-DAQ also internally addresses many of the complex issues between the computer and the DAQ hardware such as programming interrupts and DMA controllers. NI-DAQ maintains a consistent software interface among its different versions so that you can change platforms with minimal modifications to your code. Whether you are using conventional programming languages or National Instruments application software, your application uses the NI-DAQ driver software, as illustrated in Figure 1-1.

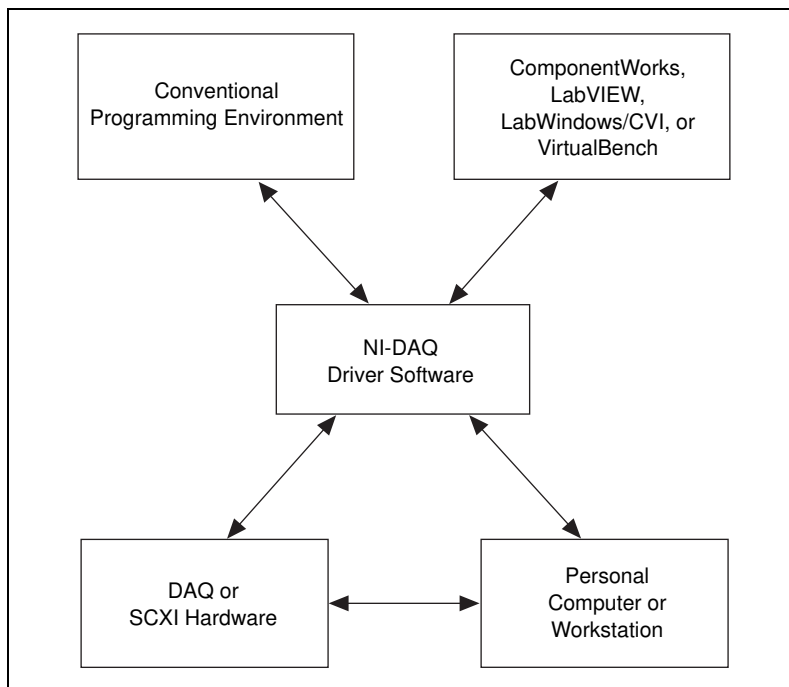

**Figure 1-1.** The Relationship between the Programming Environment, NI-DAQ, and Your Hardware

## Register-Level Programming

The final option for programming any National Instruments DAQ hardware is to write register-level software. Writing register-level programming software can be very time-consuming and inefficient, and is not recommended for most users.

Even if you are an experienced register-level programmer, using NI-DAQ or application software to program your National Instruments DAQ hardware is easier than, and as flexible as, register-level programming, and can save weeks of development time.

## Optional Equipment

---

National Instruments offers a variety of products to use with your AT-MIO-16X board, including cables, connector blocks, and other accessories, as follows:

- Cables and cable assemblies, shielded and ribbon
- Connector blocks, shielded and unshielded 50 and 68-pin screw terminals
- Real Time System Integration (RTSI) bus cables
- SCXI modules and accessories for isolating, amplifying, exciting, and multiplexing signals for relays and analog output. With SCXI you can condition and acquire up to 3,072 channels.
- Low channel count signal conditioning modules, boards, and accessories, including conditioning for strain gauges and RTDs, simultaneous sample and hold, and relays

For more specific information about these products, refer to your National Instruments catalogue or call the office nearest you.

## Unpacking

---

Your AT-MIO-16X board is shipped in an antistatic package to prevent electrostatic damage to the board. Electrostatic discharge can damage several components on the board. To avoid such damage in handling the board, take the following precautions:

- Ground yourself via a grounding strap or by holding a grounded object.
- Touch the antistatic package to a metal part of your computer chassis before removing the board from the package.
- Remove the board from the package and inspect the board for loose components or any other sign of damage. Notify National Instruments if the board appears damaged in any way. *Do not* install a damaged board into your computer.
- *Never* touch the exposed pins of connectors.

# Configuration and Installation

## Chapter 2

This chapter explains board configuration, installation of the AT-MIO-16X into the PC, signal connections to the AT-MIO-16X, and cable considerations.

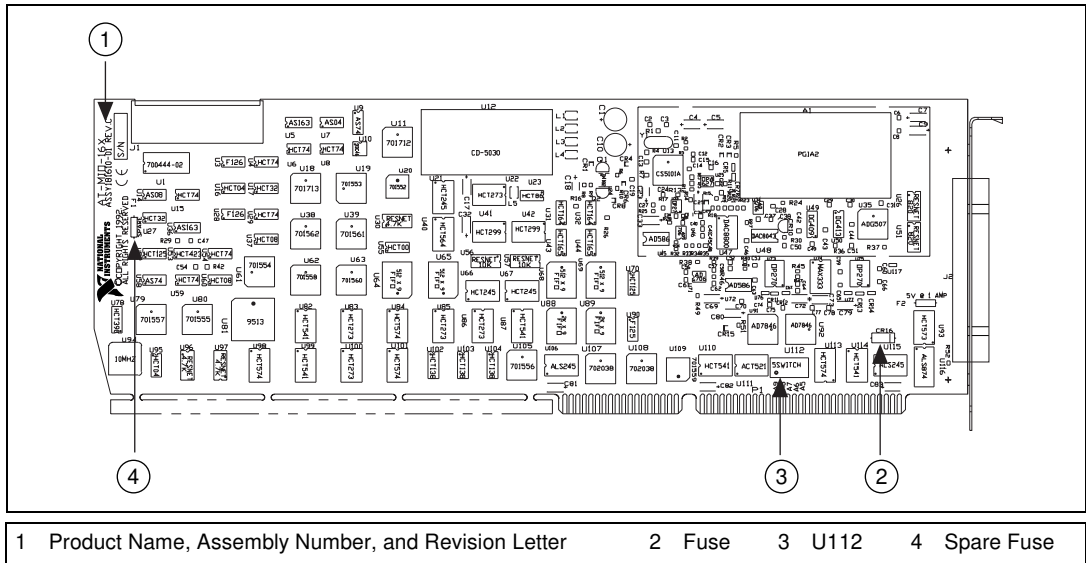

**Figure 2-1.** AT-MIO-16X with 50-Pin I/O Connector Parts Locator Diagram



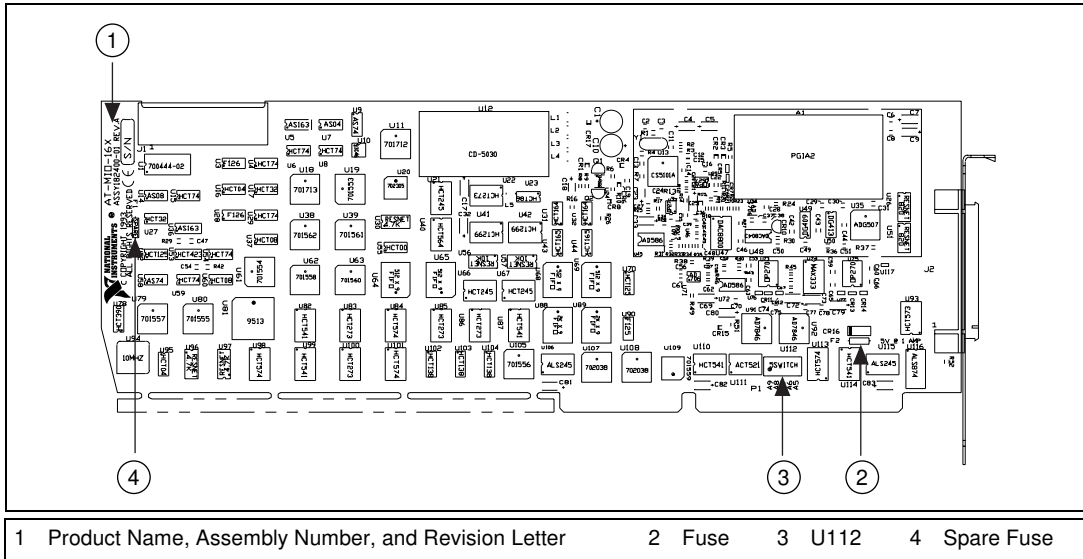

Figure 2-2. AT-MIO-16X with 68-Pin I/O Connector Parts Locator Diagram

## Board Configuration

The AT-MIO-16X contains one DIP switch to configure the base address selection for the AT bus interface. The remaining resource selections, such as DMA and interrupt channel selections, are determined by programming the individual registers in the AT-MIO-16X register set. The general location of the registers in the I/O space of the PC is determined by the base address selection, whereas the specific location of the registers within the register set is determined by the AT-MIO-16X decode circuitry.

## AT Bus Interface

Operation of the AT-MIO-16X multifunction I/O board is controlled through accesses to registers within the board register set. Some of the registers in the register set retain data written to them to determine board operation. Other registers in the register set contain important status information necessary for proper sequencing of events. Still other registers perform functions by accessing them either by reading from or writing to their location. However, these registers do not retain pertinent data when written to, nor do they provide pertinent status information when read.

The PC defines accesses to plug-in boards to be I/O mapped accesses within the I/O space of the computer. Locations are either written to or read from as bytes or words. Each register in the register set is mapped to a certain offset from the base address selection of the board as read or write, and as a word or byte location as defined by the decode circuitry.

## Base I/O Address Selection

The AT-MIO-16X is configured at the factory to a base I/O address of 220 hex. This base address setting is suitable for most systems. However, if your system has other hardware at this base I/O address, you must change either the AT-MIO-16X base address DIP switch or the other hardware base address to avoid a conflict. Figure 2-3 shows a graphical representation of the base address selection DIP switch, and also shows how to reconfigure the selected base address.

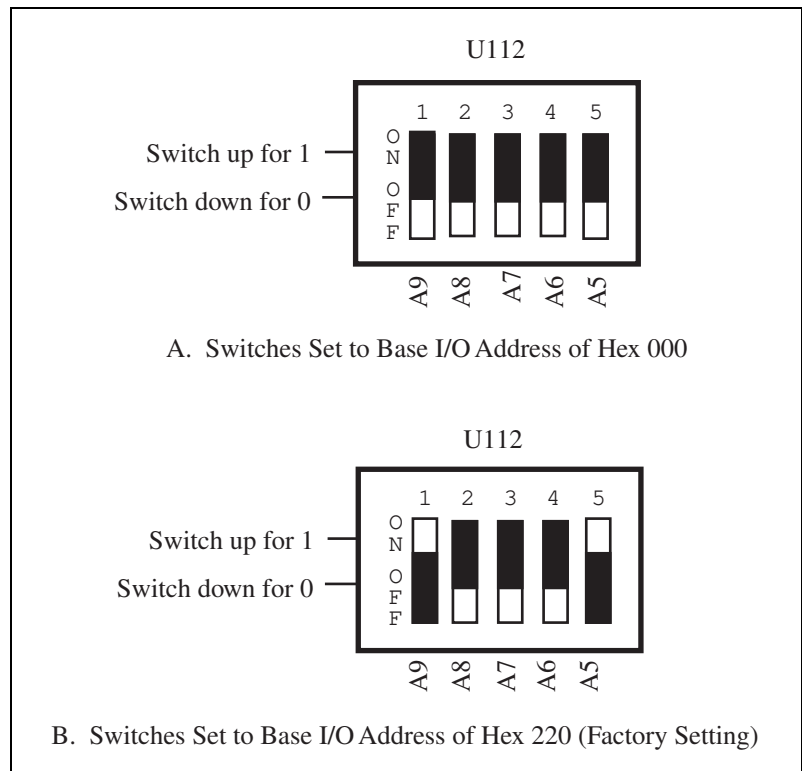

**Figure 2-3.** Example Base I/O Address Switch Settings

The base address DIP switch is arranged so that a logical 1 or *true* state for the associated address selection bit is selected by pushing the toggle switch up, or toward the top of the board. Alternately, a logical 0 or *false* state is selected by pushing the toggle switch down, or toward the bottom of the board. In Figure 2-3B, A9 is up (*true*), A8 through A6 are low (*false*), and A5 is up (*true*). This represents a binary value of 10001XXXXX, or hex 220. The Xs indicate don't care bits and are the five least significant bits (LSBs) of the address (A4 through A0) used by the AT-MIO-16X circuitry to decode the individual register selections. The don't care bits indicate the size of the register space. In this case, the AT-MIO-16X uses I/O address hex 220 through hex 23F in the factory-default setting.

**Note:**

*If you change the AT-MIO-16X base I/O address, you must make a corresponding change to any software packages you use with the AT-MIO-16X. Table 2-1 lists the default settings of other National Instruments products for the PC. Table 2-2 lists the possible switch settings, the corresponding base I/O address, and the base I/O address space used for that setting. For more information about the I/O address of your PC, refer to the technical reference manual for your computer.*

**Table 2-1.** Default Settings of National Instruments Products for the PC

Board	DMA Channel	Interrupt Level	Base I/O Address
AT-A2150	None*	None*	120 hex
AT-AO-6/10	Channel 5	Lines 11, 12	1C0 hex
AT-DIO-32F	Channels 5, 6	Lines 11, 12	240 hex
AT-DSP2200	None*	None*	120 hex
AT-GPIB	Channel 5	Line 11	2C0 hex
AT-MIO-16	Channels 6, 7	Line 10	220 hex
AT-MIO-16D	Channels 6, 7	Lines 5, 10	220 hex
AT-MIO-16F-5	Channels 6, 7	Line 10	220 hex
AT-MIO-16X	None*	None*	220 hex

**Table 2-1.** Default Settings of National Instruments Products for the PC (Continued)

Board	DMA Channel	Interrupt Level	Base I/O Address
AT-MIO-64F-5	None*	None*	220 hex
GPIB-PCII	Channel 1	Line 7	2B8 hex
GPIB-PCIIA	Channel 1	Line 7	02E1 hex
GPIB-PCIII	Channel 1	Line 7	280 hex
Lab-PC	Channel 3	Line 5	260 hex
PC-DIO-24	None	Line 5	210 hex
PC-DIO-96	None	Line 5	180 hex
PC-LPM-16	None	Line 5	260 hex
PC-TIO-10	None	Line 5	1A0 hex
* These settings are software configurable and are disabled at startup time.			

**Table 2-2.** Switch Settings with Corresponding Base I/O Address and Base I/O Address Space

Switch Setting					Base I/O Address (hex)	Base I/O Address Space Used (hex)
A9	A8	A7	A6	A5		
0	0	X	X	X	000 - E00	Reserved
0	1	0	0	0	100	100 - 11F
0	1	0	0	1	120	120 - 13F
0	1	0	1	0	140	140 - 15F
0	1	0	1	1	160	160 - 17F
0	1	1	0	0	180	180 - 19F
0	1	1	0	1	1A0	1A0 - 1BF

**Table 2-2.** Switch Settings with Corresponding Base I/O Address and Base I/O Address Space (Continued)

Switch Setting					Base I/O Address (hex)	Base I/O Address Space Used (hex)
A9	A8	A7	A6	A5		
0	1	1	1	0	1C0	1C0 - 1DF
0	1	1	1	1	1E0	1E0 - 1FF
1	0	0	0	0	200	200 - 21F
1	0	0	0	1	220	220 - 23F
1	0	0	1	0	240	240 - 25F
1	0	0	1	1	260	260 - 27F
1	0	1	0	0	280	280 - 29F
1	0	1	0	1	2A0	2A0 - 2BF
1	0	1	1	0	2C0	2C0 - 2DF
1	0	1	1	1	2E0	2E0 - 2FF
1	1	0	0	0	300	300 - 31F
1	1	0	0	1	320	320 - 33F
1	1	0	1	0	340	340 - 35F
1	1	0	1	1	360	360 - 37F
1	1	1	0	0	380	380 - 39F
1	1	1	0	1	3A0	3A0 - 3BF
1	1	1	1	0	3C0	3C0 - 3DF
1	1	1	1	1	3E0	3E0 - 3FF

## Interrupt and DMA Channel Selection

The base I/O address selection is the only resource on the AT-MIO-16X board that must be set manually before the board is placed into the PC. The interrupt level and DMA channels used by the AT-MIO-16X are selected via registers in the AT-MIO-16X register set. The AT-MIO-16X powers up with all interrupt and DMA requests disabled. To use the interrupt capability of the AT-MIO-16X, an interrupt level must first be selected via register programming, then the specific interrupt mode must be enabled. The same method holds for DMA channel selection. To use the DMA capability of the board, one or two DMA channels must be selected through the appropriate register, then the specific DMA mode must be enabled. It is possible to have interrupt and DMA resources concurrently enabled.

The interrupt lines supported by the AT-MIO-16X hardware are IRQ3, IRQ4, IRQ5, IRQ7, IRQ10, IRQ11, IRQ12, and IRQ15. The DMA channels supported are Channels 0 through 3, and Channels 5 through 7. If you use the AT-MIO-16X in an AT-type computer, you should only use DMA Channels 5 through 7 because these are the only 16-bit channels available. If you use the board in an EISA computer, all channels are capable of 16-bit transfers and you can use them. The AT-MIO-16X *does not* use and *cannot* be configured to use the 8-bit DMA Channels 0 through 3 on the PC I/O channel for 16-bit transfers.

## Analog Input Configuration

---

The analog input section of the AT-MIO-16X is software configurable. You can select different analog input configurations by programming the appropriate register in the AT-MIO-16X register set. The following paragraphs describe in detail each of the analog input categories.

### Input Mode

The AT-MIO-16X offers three different input modes: single-ended (SE) input, referenced single-ended (RSE) input, and differential (DIFF) input. The single-ended input configurations use up to 16 channels. The DIFF input configuration uses up to eight channels. Input modes are programmed on a per channel basis for multimode scanning. For example, the circuitry can be configured to effectively scan 12 channels, four differentially configured channels and eight single-ended channels. The input configurations are described in Table 2-3.

**Table 2-3.** Available Input Configurations for the AT-MIO-16X

Configuration	Description
DIFF	Differential configuration input of the PGIA tied to the multiplexer output of Channels 8 through 15.
RSE	Referenced single-ended configuration negative (-) input of the PGIA referenced to analog ground.
NRSE	Nonreferenced single-ended configuration negative (-) input of the PGIA tied to AI SENSE and <i>not</i> connected to ground.

While reading the following paragraphs, you may find it helpful to refer to the *Analog Input Signal Connections* section later in this chapter, which contains diagrams showing the signal paths for the three configurations.

## DIFF Input (Eight Channels)

DIFF input means that each input signal has its own reference, and the difference between each signal and its reference is measured. The signal and its reference are assigned an input channel. This is the recommended configuration. With this input configuration, the AT-MIO-16X can monitor up to eight different analog input signals. This configuration is selected via software. See the configuration memory register and Table 4-9 in Chapter 4, *Register Map and Descriptions*. The results of this configuration are as follows:

- One of Channels 0 through 7 is tied to the positive (+) input of the PGIA.
- One of Channels 8 through 15 is tied to the negative (-) input of the PGIA.
- Multiplexer control is configured to control up to eight input channels.
- AI SENSE may be driven by the board analog input ground or left unconnected.

Considerations for using the DIFF input configuration are discussed in the *Signal Connections* section later in this chapter. Figure 2-8 shows a schematic diagram of this configuration.

## RSE Input (16 Channels)

RSE input means that all input signals are referenced to a common ground point that is also tied to the analog input ground of the AT-MIO-16X board. The negative (–) input of the differential input amplifier is tied to the analog ground. This configuration is useful when measuring floating signal sources. See the *Types of Signal Sources* section later in this chapter for more information. With this input configuration, the AT-MIO-16X can monitor up to 16 different analog input signals. This configuration is selected via software. See the configuration memory register and Table 4-9 in Chapter 4, *Register Map and Descriptions*. The results of this configuration are as follows:

- The negative (–) input of the PGIA is tied to the PGIA signal ground.
- Multiplexer outputs are tied together into the positive (+) input of the PGIA.
- Multiplexer control is configured to control up to 16 input channels.
- AI SENSE may be driven by the board analog input ground or left unconnected.

Considerations for using the RSE configuration are discussed in the *Signal Connections* section later in this chapter. Figure 2-18 shows a schematic diagram of this configuration.

## NRSE Input (16 Channels)

NRSE input means that all input signals are referenced to the same common-mode voltage, but this common-mode voltage can float with respect to the analog ground of the AT-MIO-16X board. This common-mode voltage is subsequently subtracted from the signals by the input PGIA. This configuration is useful when measuring ground-referenced signal sources. See the *Types of Signal Sources* section later in this chapter for more information. With this input configuration, the AT-MIO-16X can measure up to 16 different analog input signals. This configuration is selected via software. See the configuration memory register and Table 4-9 in Chapter 4, *Register Map and Descriptions*, for additional information. The results of this configuration are as follows:

- AI SENSE is tied into the negative (–) input of the PGIA.
- Multiplexer outputs are tied together into the positive (+) input of the PGIA.



- Multiplexer control is configured to control up to 16 input channels.



**Note:** *The NRSE input mode is the only mode in which the AI SENSE signal from the I/O connector is used as an input. In all other modes, AI SENSE is either programmed to be unused or driven with the board analog input ground.*

Considerations for using the NRSE input configuration are discussed in the *Signal Connections* section later in this chapter. Figure 2-8 shows a schematic diagram of this configuration.

## Input Polarity and Input Range

The AT-MIO-16X has two polarities: unipolar input and bipolar input. Unipolar input means that the input voltage range is between 0 and  $V_{ref}$  where  $V_{ref}$  is a positive reference voltage. Bipolar input means that the input voltage range is between  $-V_{ref}$  and  $+V_{ref}$ . The AT-MIO-16X has a maximum unipolar input range of 10 V, and a maximum bipolar input range of 20 V ( $\pm 10$  V). Polarity and range settings are programmed on a per channel basis through the configuration memory register.

## Considerations for Selecting Input Ranges

Input polarity and range selection depend on the expected input range of the incoming signal. A large input range can accommodate a large signal variation but lowers the voltage resolution. Choosing a smaller input range increases the voltage resolution but may result in the input signal going out of range. For best results, the input range should be matched as closely as possible to the expected range of the input signal. For example, if the input signal is certain not to be negative (below 0 V), a unipolar input is best. However, if the signal is ever negative, inaccurate readings will occur if unipolar input polarity is used.

The software-programmable gain on the AT-MIO-16X increases its overall flexibility by matching the input signal ranges to those that the AT-MIO-16X analog-to-digital converter (ADC) can accommodate. The AT-MIO-16X board has gains of 1, 2, 5, 10, 20, 50, and 100 and is suited for a wide variety of signal levels. With the proper gain setting, the full resolution of the ADC can be used to measure the input signal. Table 2-4 shows the overall input range and precision according to the input range configuration and gain used.

**Table 2-4.** Actual Range and Measurement Precision Versus Input Range Selection and Gain

Range Configuration	Gain	Actual Input Range	Precision*
0 to +10 V	1.0	0 to +10.0 V	152.59 $\mu$ V
	2.0	0 to +5.0 V	76.29 $\mu$ V
	5.0	0 to +2.0 V	30.52 $\mu$ V
	10.0	0 to +1.0 V	15.26 $\mu$ V
	20.0	0 to +0.5 V	7.63 $\mu$ V
	50.0	0 to +0.2 V	3.05 $\mu$ V
	100.0	0 to 100.0 mV	1.53 $\mu$ V
	-10 to +10 V	1.0	-10.0 to +10.0 V
2.0		-5.0 to +5.0 V	152.59 $\mu$ V
5.0		-2.0 to +2.0 V	61.04 $\mu$ V
10.0		-1.0 to +1.0 V	30.52 $\mu$ V
20.0		-0.5 to +0.5 V	15.26 $\mu$ V
50.0		-0.2 to +0.2 V	6.10 $\mu$ V
100.0		-100.0 to +100.0 mV	3.05 $\mu$ V
<p>* The value of 1 LSB of the 16-bit ADC; that is, the voltage increment corresponding to a change of 1 count in the ADC 16-bit count.</p> <p><b>Note:</b> See Appendix A, <i>Specifications</i>, for absolute maximum ratings.</p>			

## Analog Output Configuration

The AT-MIO-16X supplies two channels of analog output voltage at the I/O connector. The analog output circuitry is configurable through programming of a register in the board register set. The reference and range for the analog output circuitry can be selected through software. The reference can be either internal or external, whereas the range can be either bipolar or unipolar.

## Analog Output Reference Selection

Each DAC can be connected to the AT-MIO-16X internal reference of 10 V or to the external reference signal connected to the EXTREF pin on the I/O connector. This signal applied to EXTREF must be between -18 and +18 V. Both channels need not be configured for the same mode.

## Analog Output Polarity Selection

Each analog output channel can be configured for either unipolar or bipolar output. A unipolar configuration has a range of 0 to  $V_{\text{ref}}$  at the analog output. A bipolar configuration has a range of  $-V_{\text{ref}}$  to  $+V_{\text{ref}}$  at the analog output.  $V_{\text{ref}}$  is the voltage reference used by the DACs in the analog output circuitry and can be either the 10-V onboard reference or an externally supplied reference between  $-18$  and  $+18$  V. Both channels need not be configured for the same range.

Selecting a bipolar range for a particular DAC means that any data written to that DAC will be interpreted as two's complement format. In two's complement mode, data values written to the analog output channel range from  $-32,768$  to  $+32,767$  decimal (8000 to 7FFF hex). If unipolar range is selected, data is interpreted in straight binary format. In straight binary mode, data values written to the analog output channel range from 0 to 65,535 decimal (0 to FFFF hex).

## Digital I/O Configuration

---

The AT-MIO-16X contains eight lines of digital I/O for general-purpose use. The eight digital I/O lines supplied are configured as two 4-bit ports. Each port can be individually configured through programming of a register in the board register set as either input or output. At system startup and reset, the digital I/O ports are both configured for input.

## Board and RTSI Clock Configuration

---

When multiple AT Series boards are connected via the RTSI bus, you may want all of the boards to use the same 10-MHz clock. This arrangement is useful for applications that require counter/timer synchronization between boards. Each AT Series board with a RTSI bus interface has an onboard 10-MHz oscillator. Thus, one board can drive the RTSI bus clock signal, and the other boards can receive this signal or disconnect from it.

Many functions performed by the AT-MIO-16X board require a frequency timebase to generate the necessary timing signals for controlling ADC conversions, DAC updates, or general-purpose signals at the I/O connector. You select this timebase through programming one of the registers in the AT-MIO-16X register set.

The AT-MIO-16X can use either its internal 10-MHz timebase, or it can use a timebase received over the RTSI bus. In addition, if the board is configured to use the internal timebase, it can also be programmed to drive its internal timebase over the RTSI bus to another board that is programmed to receive this timebase signal. This clock source, whether local or from the RTSI bus, is then divided by 10 and used as the Am9513A frequency source. The default configuration at startup is to use the internal timebase without driving the RTSI bus timebase signal.

## Hardware Installation

---

You can install the AT-MIO-16X in any available 16-bit expansion slot in your AT Series computer. However, to achieve best noise performance, you should leave as much room as possible between the AT-MIO-16X and other boards and hardware. The AT-MIO-16X *does not* work if installed in an 8-bit expansion slot (PC Series). After you have made any necessary changes, verified, and recorded the switches and jumper settings (a form is included for this purpose in Appendix D, *Customer Communication*), you are ready to install the AT-MIO-16X. The following are general installation instructions, but consult your PC user manual or technical reference manual for specific instructions and warnings.

1. Turn off your computer.
2. Remove the top cover or access port to the I/O channel.
3. Remove the expansion slot cover on the back panel of the computer.
4. Insert the AT-MIO-16X into a 16-bit slot. Do not force the board into place. Verify that there are no extended components on the circuit board of the computer that may touch or be in the way of any part of the AT-MIO-16X.
5. Attach a RTSI cable to the RTSI connectors to connect AT Series boards to each other.
6. Screw the AT-MIO-16X mounting bracket to the back panel rail of the computer.
7. Check the installation.
8. Replace the cover.

The AT-MIO-16X board is installed and ready for operation.

## Signal Connections

---

This section describes input and output signal connections to the AT-MIO-16X board via the AT-MIO-16X I/O connector. This section also includes specifications and connection instructions for the signals given on the AT-MIO-16X I/O connector.



**Caution:** *Connections that exceed any of the maximum ratings of input or output signals on the AT-MIO-16X can result in damage to the AT-MIO-16X board and to the PC. Maximum input ratings for each signal are given in this chapter under the discussion of that signal. National Instruments is not liable for any damages resulting from such signal connections.*

Figure 2-4 shows the pin assignments for the AT-MIO-16X 50-pin I/O connector.

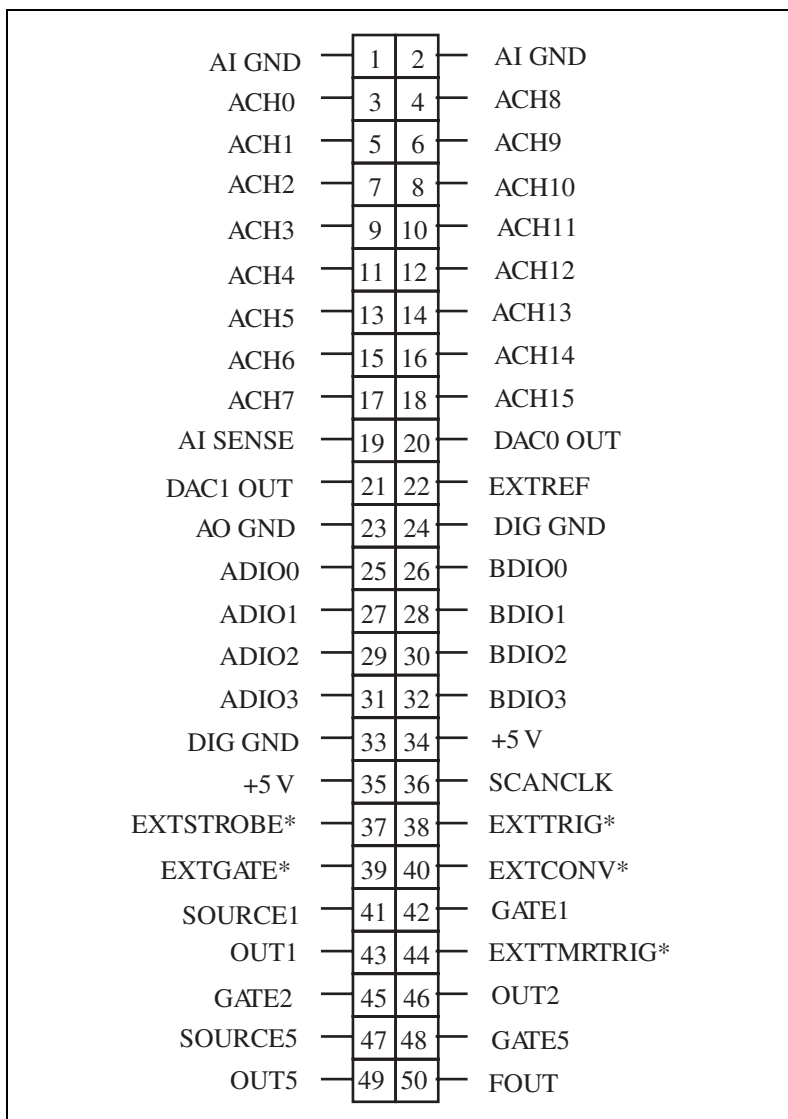

**Figure 2-4.** AT-MIO-16X 50-Pin I/O Connector

Figure 2-5 shows the pin assignments for the AT-MIO-16X 68-pin I/O connector.

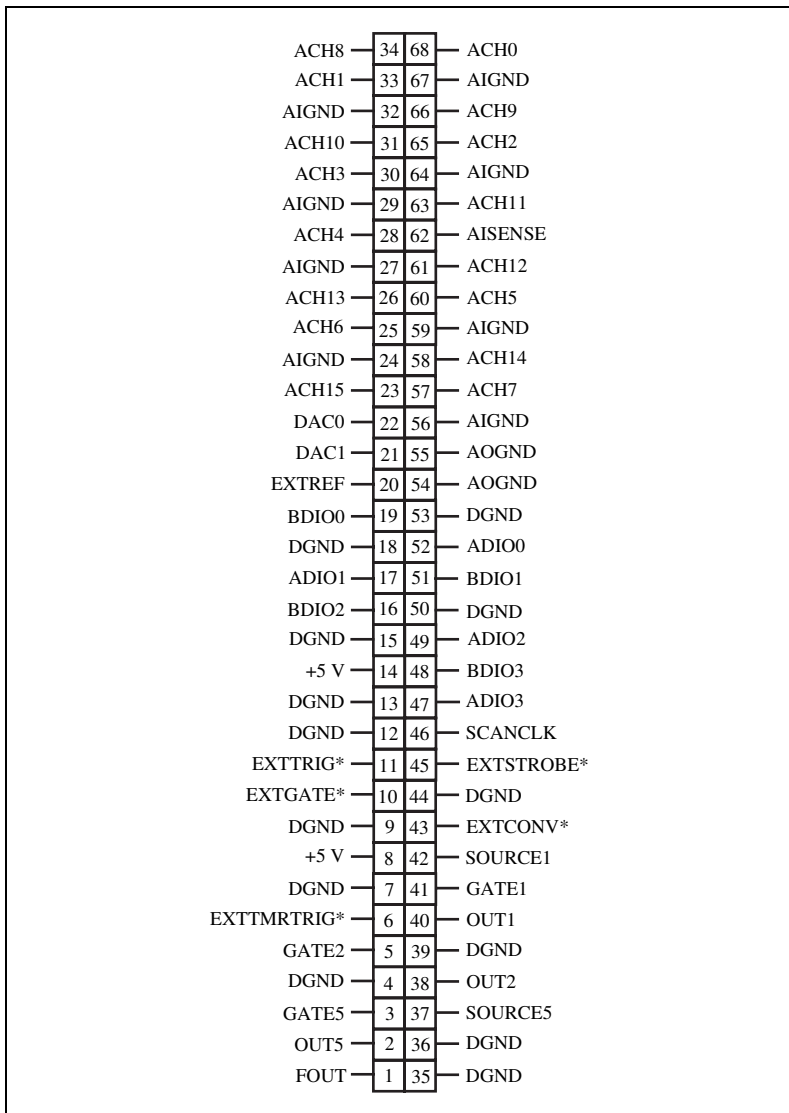

**Figure 2-5.** AT-MIO-16X 68-Pin I/O Connector

## Signal Connection Descriptions

Signal Names	Reference	Descriptions
AI GND	N/A	Analog Input Ground—These pins are the reference point for single-ended measurements and the bias current return point for differential measurements.
ACH<0..15>	AI GND	Analog Input Channels 0 through 15—In differential mode, the input is configured for up to eight channels. In single-ended mode, the input is configured for up to 16 channels.
AI SENSE	AI GND	Analog Input Sense—This pin serves as the reference node when the board is in NRSE configuration. If desired, this signal can be programmed to be driven by the board analog input ground in the DIFF and RSE analog input modes.
DAC0 OUT	AO GND	Analog Channel 0 Output—This pin supplies the voltage output of analog output Channel 0.
DAC1 OUT	AO GND	Analog Channel 1 Output—This pin supplies the voltage output of analog output Channel 1.
EXTREF	AO GND	External Reference—This is the external reference input for the analog output circuitry.
AO GND	N/A	Analog Output Ground—The analog output voltages are referenced to this node.
DIG GND	N/A	Digital Ground—This pin supplies the reference for the digital signals at the I/O connector as well as the +5 VDC supply.
ADIO<0..3>	DIG GND	Digital I/O port A signals.
BDIO<0..3>	DIG GND	Digital I/O port B signals.
+5 V	DIG GND	+5 VDC Source—These pins are fused for up to 1 A of +5 V supply.



Signal Names	Reference	Descriptions
SCANCLK	DIG GND	Scan Clock—This pin pulses once for each A/D conversion in the scanning modes. The low-to-high edge indicates when the input signal can be removed from the input or switched to another signal.
EXTSTROBE*	DIG GND	External Strobe—Writing to the EXTSTROBE Register results in a minimum 500-nsec low pulse on this pin.
EXTTRIG*	DIG GND	External Trigger—In posttrigger data acquisition sequences, a high-to-low edge on EXTTRIG* initiates the sequence. In pretrigger applications, the first high-to-low edge of EXTTRIG* initiates pretrigger conversions while the second high-to-low edge initiates the posttrigger sequence.
EXTGATE*	DIG GND	External Gate—When EXTGATE* is low, A/D conversions are inhibited. When EXTGATE* is high, A/D conversions are enabled.
EXTCONV*	DIG GND	External Convert—A high-to-low edge on EXTCONV* causes an A/D conversion to occur. Conversions initiated by the EXTCONV* signal are inhibited outside of a data acquisition sequence, and when gated off.
SOURCE1	DIG GND	SOURCE1—This pin is from the Am9513A Counter 1 signal.
GATE1	DIG GND	GATE1—This pin is from the Am9513A Counter 1 signal.
OUT1	DIG GND	OUTPUT1—This pin is from the Am9513A Counter 1 signal.
EXTTMRTRIG*	DIG GND	External Timer Trigger—If selected, a high-to-low edge on EXTTMRTRIG* results in the output DACs being updated with the value written to them in the posted update mode. EXTTMRTRIG* will also generate a timed interrupt if enabled.
GATE2	DIG GND	GATE2—This pin is from the Am9513A Counter 2 signal.
OUT2	DIG GND	OUTPUT2—This pin is from the Am9513A Counter 2 signal.
SOURCE5	DIG GND	SOURCE5—This pin is from the Am9513A Counter 5 signal.
GATE5	DIG GND	GATE5—This pin is from the Am9513A Counter 5 signal.

Signal Names	Reference	Descriptions
OUT5	DIG GND	OUT5—This pin is from the Am9513A Counter 5 signal.
FOUT	DIG GND	Frequency Output—This pin is from the Am9513A FOUT signal.

The signals on the connector can be classified as analog input signals, analog output signals, digital I/O signals, digital power connections, or timing I/O signals. Signal connection guidelines for each of these groups are given in the following section.

## Analog Input Signal Connections

AI GND is an analog input common signal that is routed directly to the ground tie point on the AT-MIO-16X. These pins can be used for a general analog power ground tie point to the AT-MIO-16X if necessary. In NRSE mode, AI SENSE is connected internally to the negative (–) input of the AT-MIO-16X PGIA. In the DIFF and RSE modes, this signal is driven by AI GND or left unconnected.

Signal pins ACH<0..15> are tied to the 16 analog input channels of the AT-MIO-16X. In single-ended mode, signals connected to ACH<0..15> are routed to the positive (+) input of the AT-MIO-16X PGIA. In differential mode, signals connected to ACH<0..7> are routed to the positive (+) input of the AT-MIO-16X PGIA, and signals connected to ACH<8..15> are routed to the negative (–) input of the AT-MIO-16X PGIA.



**Caution:** *Exceeding the differential and common-mode input ranges results in distorted input signals. Exceeding the maximum input voltage rating can result in damage to the AT-MIO-16X board and to the PC. National Instruments is not liable for any damages resulting from such signal connections.*

Connection of analog input signals to the AT-MIO-16X depends on the configuration of the AT-MIO-16X analog input circuitry and the type of input signal source. With the different AT-MIO-16X configurations, you can use the AT-MIO-16X PGIA in different ways. Figure 2-6 shows a diagram of the AT-MIO-16X PGIA.

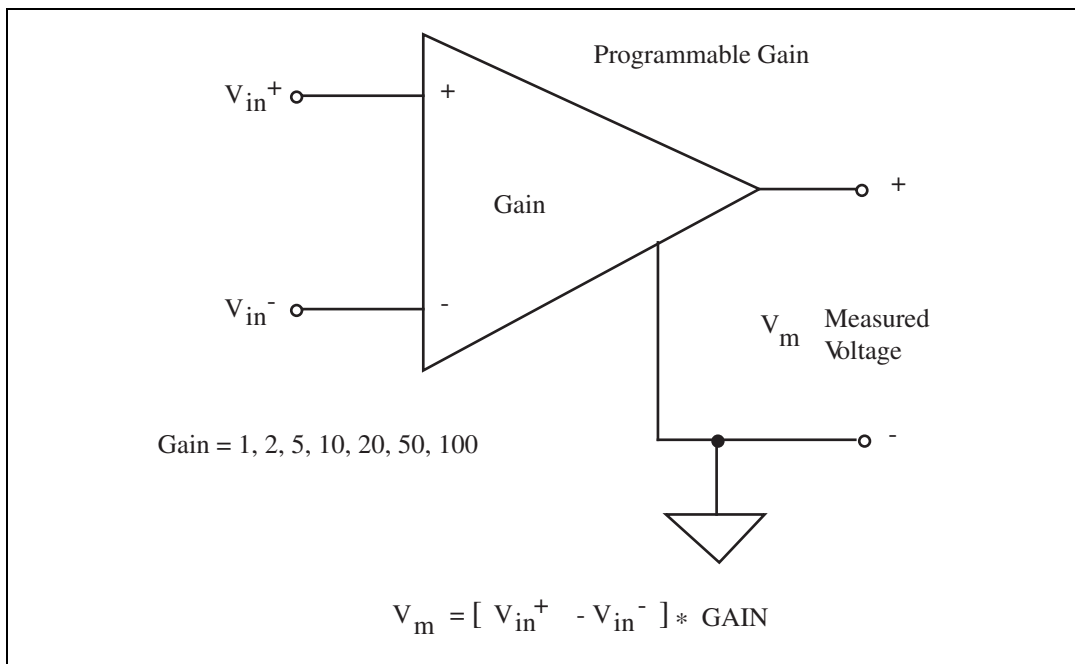

**Figure 2-6.** AT-MIO-16X PGIA

The AT-MIO-16X PGIA applies gain and common-mode voltage rejection, and presents high-input impedance to the analog input signals connected to the AT-MIO-16X board. Signals are routed to the positive (+) and negative (-) inputs of the PGIA through input multiplexers on the AT-MIO-16X. The PGIA converts two input signals to a signal that is the difference between the two input signals multiplied by the gain setting of the amplifier. The amplifier output voltage is referenced to the AT-MIO-16X ground. The AT-MIO-16X ADC measures this output voltage when it performs A/D conversions.

All signals must be referenced to ground, either at the source device or at the AT-MIO-16X. If you have a floating source, the AT-MIO-16X should reference the signal to ground by using the RSE input mode or the DIFF input configuration with bias resistors (see the *Differential Connections for Nonreferenced or Floating Signal Sources* section later in this chapter). If you have a grounded source, the AT-MIO-16X should not reference the signal to AI GND. The AT-MIO-16X board avoids this reference by using the DIFF or NRSE input configurations.

## Types of Signal Sources

When configuring the input mode of the AT-MIO-16X and making signal connections, you must first determine whether the signal source is floating or ground-referenced. These two types of signals are described in the following sections.

### Floating Signal Sources

A floating signal source is one that is not connected in any way to the building ground system but rather has an isolated ground reference point. Some examples of floating signal sources are outputs of transformers, thermocouples, battery-powered devices, optical isolator outputs, and isolation amplifiers. An instrument or device that provides an isolated output falls into the floating signal source category. The ground reference of a floating signal must be tied to the AT-MIO-16X analog input ground in order to establish a local or onboard reference for the signal. Otherwise, the measured input signal varies as the source floats out of the common-mode input range.

### Ground-Referenced Signal Sources

A ground-referenced signal source is one that is connected in some way to the building system ground and is therefore already connected to a common ground point with respect to the AT-MIO-16X board, assuming that the PC AT is plugged into the same power system. Nonisolated outputs of instruments and devices that plug into the building power system fall into this category.

The difference in ground potential between two instruments connected to the same building power system is typically between 1 mV and 100 mV but can be much higher if power distribution circuits are not properly connected. If grounded signal source is improperly measured, this difference may show up as an error in the measurement. The following connection instructions for grounded signal sources are designed to eliminate this ground potential difference from the measured signal.

## Input Configurations

The AT-MIO-16X can be configured for one of three input modes: NRSE, RSE, or DIFF. The following sections discuss the use of single-ended and differential measurements, and considerations for measuring both floating and ground-referenced signal sources.

Table 2-5 summarizes the recommended input configuration for both types of signal sources.

**Table 2-5.** Recommended Input Configurations for Ground-Referenced and Floating Signal Sources

Type of Signal	Recommended Input Configuration
Ground-referenced (nonisolated outputs, plug-in instruments)	DIFF NRSE
Floating (batteries, thermocouples, isolated outputs)	DIFF with bias resistors RSE

## Differential Connection Considerations (DIFF Input Configuration)

Differential connections are those in which each AT-MIO-16X analog input signal has its own reference signal or signal return path. These connections are available when the AT-MIO-16X is configured in the DIFF input mode. Each input signal is tied to the positive (+) input of the PGIA; and its reference signal, or return, is tied to the negative (-) input of the PGIA.

When the AT-MIO-16X is configured for differential input, each signal uses two multiplexer inputs—one for the signal and one for its reference signal. Therefore, with a differential configuration, up to eight analog input channels are available. Differential input connections should be used when any of the following conditions are present:

- You are connecting eight or fewer signals to the AT-MIO-16X.
- Input signals are low level (less than 1 V).
- Leads connecting the signals to the AT-MIO-16X are greater than 10 ft.
- Any of the input signals require a separate ground-reference point or return signal.
- The signal leads travel through noisy environments.

Differential signal connections reduce picked-up noise and increase common-mode noise rejection. Differential signal connections also permit input signals to float within the common-mode limits of the PGIA.

## Differential Connections for Ground-Referenced Signal Sources

Figure 2-7 shows how to connect a ground-referenced signal source to an AT-MIO-16X board configured in the DIFF input mode. The AT-MIO-16X analog input circuitry must be configured for DIFF input to make these types of connections. Configuration instructions are included in Chapter 4, *Register Map and Descriptions*.

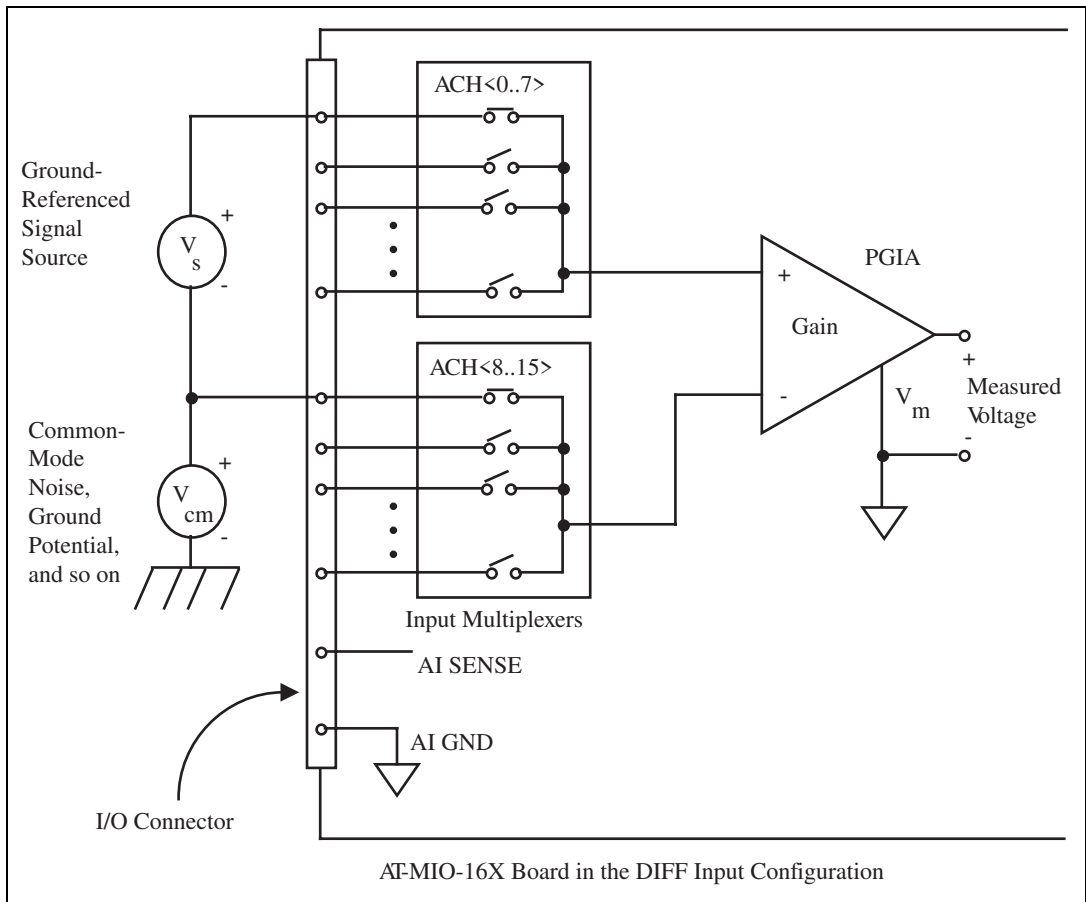
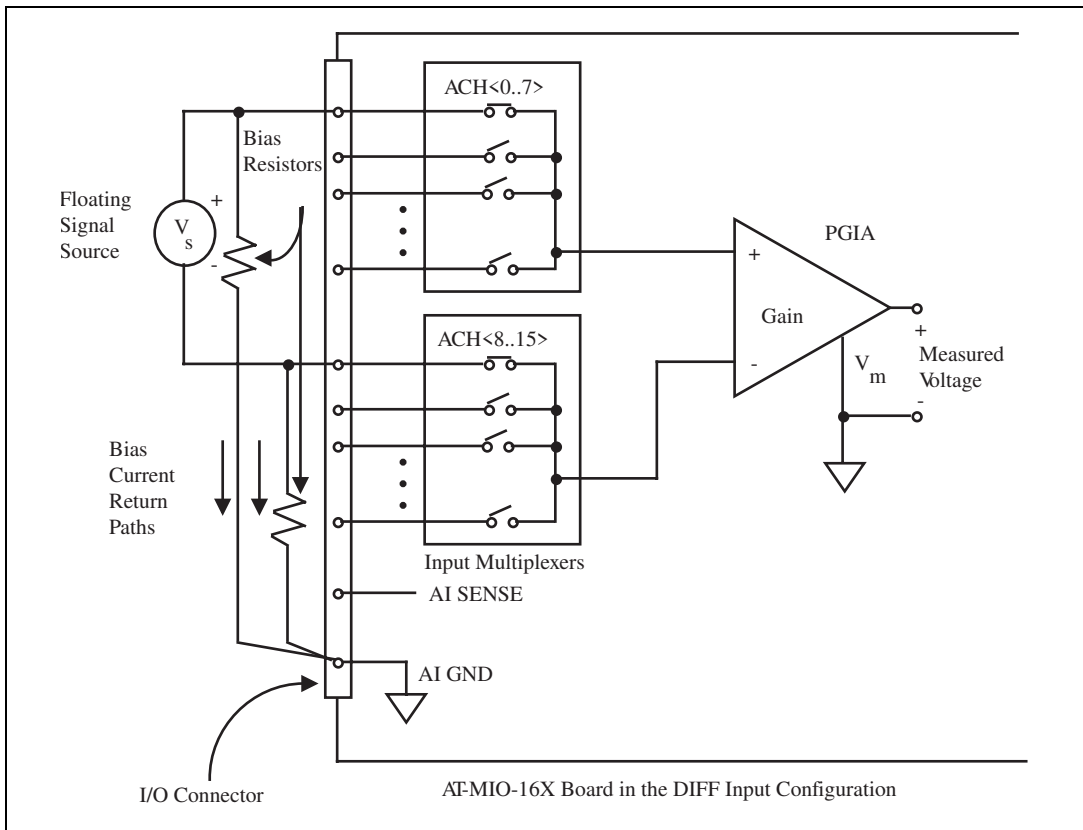

**Figure 2-7.** Differential Input Connections for Ground-Referenced Signals

With this type of connection, the PGIA rejects both the common-mode noise in the signal and the ground potential difference between the signal source and the AT-MIO-16X ground, shown as  $V_{cm}$  in Figure 2-7.

## Differential Connections for Nonreferenced or Floating Signal Sources

Figure 2-8 shows how to connect a floating signal source to an AT-MIO-16X board configured in the DIFF input mode. The AT-MIO-16X analog input circuitry must be configured for DIFF input to make these types of connections. Configuration instructions are included in Chapter 4, *Register Map and Descriptions*.



**Figure 2-8.** Differential Input Connections for Nonreferenced Signals

Figure 2-8 shows two bias resistors connected in parallel with the signal leads of a floating signal source. If the source is truly floating, it is not likely to remain within the common-mode signal range of the PGIA, and the PGIA will saturate (causing erroneous readings). You must reference the source to AI GND. The best way is simply to connect the positive side of the signal to the positive (+) input of the PGIA and

connect the negative side of the signal to AI GND as well as to the negative (–) input of the PGIA. This works well for DC-coupled sources with low source impedance (less than 100  $\Omega$ ). However, for larger source impedances, this connection leaves the differential signal path significantly out of balance. Noise that couples electrostatically onto the positive (+) line does not couple onto the negative (–) line because it is connected to ground. Hence, this noise appears as a differential-mode signal instead of a common-mode signal, and so the PGIA does not reject it. In this case, instead of directly connecting the negative (–) line to AI GND, connect it to AI GND through a resistor that is about 100 times the equivalent source impedance. This puts the signal path nearly in balance, so about the same noise couples onto both (+) and (–) connections, yielding better rejection of electrostatically coupled noise. Also, this configuration does not load down the source (other than the 100-G $\Omega$  input impedance of the PGIA). You can fully balance the signal path by connecting another resistor of the same value between the positive (+) input and AI GND. This fully balanced configuration offers slightly better noise rejection, but has the disadvantage of loading the source down with the series combination (sum) of the two resistors. If, for instance, the source impedance is 2 k $\Omega$  and the two resistors are each 100 k $\Omega$ , the resistors load down the source with 200 k $\Omega$  and produce a –1% gain error.

Both inputs of the PGIA require a DC path to ground in order for the PGIA to work. If the source is AC coupled (capacitively coupled), then the PGIA needs a resistor between the positive (+) input and AI GND. If the source has low impedance, choose a resistor that is large enough not to significantly load the source, but small enough not to produce significant input offset voltage as a result of input bias current (typically 100 k $\Omega$  to 1 M $\Omega$ ). If the source has high output impedance, you should balance the signal path (as described above) using the same value resistor on both the positive (+) and negative (–) inputs, and you should be aware that there is some gain error from loading down the source.

The PGIA obtains its input DC bias currents from the DC paths to ground. These currents are typically less than  $\pm 1$  nA, but they contribute significantly to error whenever the source has more than 1 k $\Omega$  impedance or is AC coupled. If the source is DC coupled, the resulting DC offset is less than 1 nA times the DC source resistance. For instance, a 1-k $\Omega$  source will produce no more than 1  $\mu$ V of input offset (0.33 LSB at a gain of 100, bipolar range). If the source is AC coupled, then the resulting DC offset is less than 1 nA times the sum of the two bias



resistors. For example, if two 100-k $\Omega$  bias resistors are used, there could be as much as 200  $\mu$ V of input offset voltage (0.66 LSB at a gain of 1, bipolar range).

## Single-Ended Connection Considerations

Single-ended connections are those in which all AT-MIO-16X analog input signals are referenced to one common ground. The input signals are tied to the positive (+) input of the PGIA, and their common ground point is tied to the negative (–) input of the PGIA.

When the AT-MIO-16X is configured for single-ended input, up to 16 analog input channels are available. Single-ended input connections can be used when all input signals meet the following criteria:

- Input signals are high level (greater than 1 V).
- Leads connecting the signals to the AT-MIO-16X are less than 15 ft.
- All input signals share a common-reference signal (at the source) or are floating.

DIFF input connections are recommended for greater signal integrity if any of the preceding criteria are not met.

The AT-MIO-16X can be software-configured for two different types of single-ended connections: RSE configuration and NRSE configuration. The RSE configuration is used for floating signal sources; in this case, the AT-MIO-16X provides the reference ground point for the external signal. The NRSE input configuration is used for ground-referenced signal sources; in this case, the external signal supplies its own reference ground point and the AT-MIO-16X should not supply one.

If using the AT-MIO-16X with a 50-pin I/O connector in single-ended configurations, more electrostatic and magnetic noise couples into the signal connections than in differential configurations. Moreover, the amount of coupling varies among channels, especially if a ribbon cable is used. The coupling is the result of differences in the signal path. Magnetic coupling is proportional to the area between the two signal conductors. Electrical coupling is a function of how much the electric field differs between the two conductors. If AI GND is used as the signal reference, Channels 0 and 8 are the quietest and Channels 7 and 15 are the noisiest. AI GND is on pins 1 and 2, which are very close to pins 3 and 4, which are Channels 0 and 1. On the other hand, Channels 7

and 15 are on pins 17 and 18, which are the farthest analog inputs from AI GND. The sensitivities to noise of the other channels in the middle are between those of Channels 0 and 15 and vary according to their distance from AI GND. If AI SENSE is used as a reference instead of AI GND, the sensitivity to noise still varies among the channels, but in this case according to their distance from AI SENSE, pin 19 (so Channel 15 is the least sensitive and Channel 0 is the most sensitive).

## Single-Ended Connections for Floating Signal Sources (RSE Configuration)

Figure 2-9 shows how to connect a floating signal source to an AT-MIO-16X board configured for single-ended input. The AT-MIO-16X analog input circuitry must be configured for RSE input to make these types of connections. Configuration instructions are included in Chapter 4, *Register Map and Descriptions*.

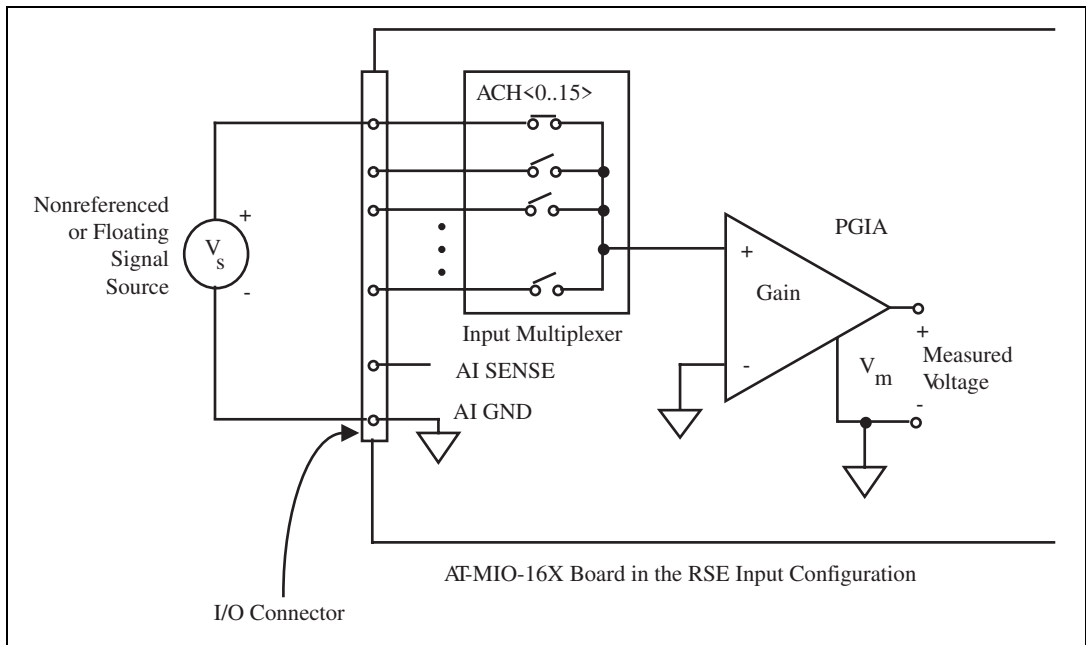
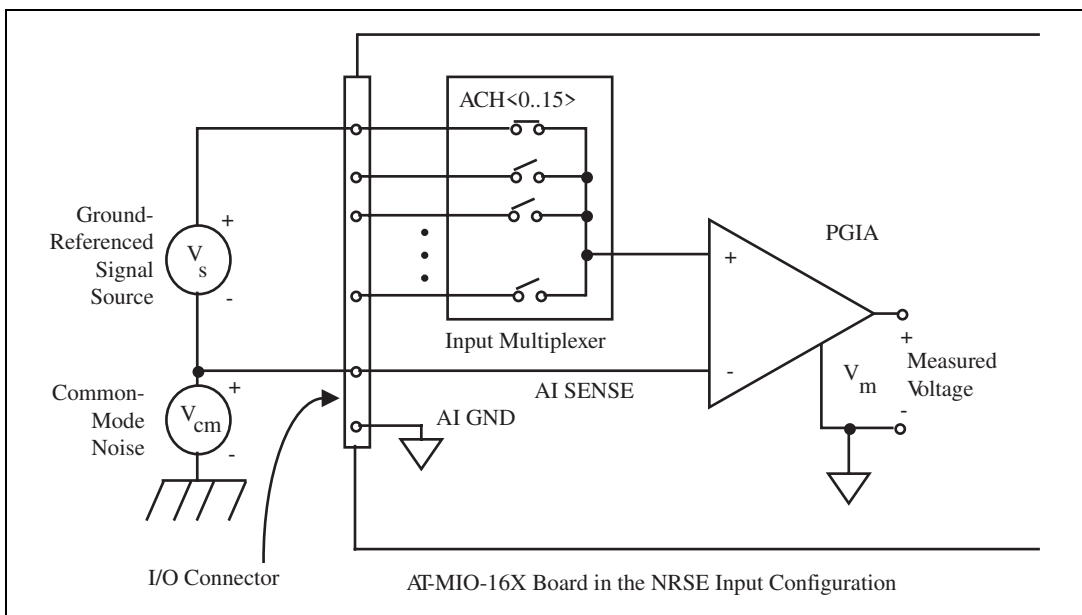

**Figure 2-9.** Single-Ended Input Connections for Nonreferenced or Floating Signals

## Single-Ended Connections for Grounded Signal Sources (NRSE Configuration)

If a grounded signal source is to be measured with a single-ended configuration, then the AT-MIO-16X must be configured in the NRSE input configuration. The signal is connected to the positive (+) input of the AT-MIO-16X PGIA and the signal local ground reference is connected to the negative (-) input of the AT-MIO-16X PGIA. The ground point of the signal should therefore be connected to the AI SENSE pin. Any potential difference between the AT-MIO-16X ground and the signal ground appears as a common-mode signal at both the positive (+) and negative (-) inputs of the PGIA and this difference is rejected by the amplifier. On the other hand, if the input circuitry of the AT-MIO-16X is referenced to ground, such as in the RSE input configuration, this difference in ground potentials appears as an error in the measured voltage.

Figure 2-10 shows how to connect a grounded signal source to an AT-MIO-16X board configured for nonreferenced single-ended input. The AT-MIO-16X analog input circuitry must be configured for NRSE input configuration to make these types of signals. Configuration instructions are included in Chapter 4, *Register Map and Descriptions*.



**Figure 2-10.** Single-Ended Input Connections for Ground-Referenced Signals

## Common-Mode Signal Rejection Considerations

Figures 2-7 and 2-8, located earlier in this chapter, show connections for signal sources that are already referenced to some ground point with respect to the AT-MIO-16X. In these cases, the PGIA can reject any voltage caused by ground potential differences between the signal source and the AT-MIO-16X. In addition, with differential input connections, the PGIA can reject common-mode noise pickup in the leads connecting the signal sources to the AT-MIO-16X.

The common-mode input range of the AT-MIO-16X PGIA is defined as the magnitude of the greatest common-mode signal that can be rejected. The PGIA can reject common-mode signals as long as  $V_{+in}$  and  $V_{-in}$  are both in the range  $\pm 11$  V. Thus, the common-mode range for the AT-MIO-16X depends on the size of the differential input signal ( $V_{diff} = V_{+in} - V_{-in}$ ). The exact formula for the allowed common-mode input range is as follows:

$$V_{cm-max} = \pm(11 \text{ V} - V_{diff}/2)$$

With a differential voltage of 10 V, the maximum possible common-mode voltage is  $\pm 6$  V. The common-mode voltage is measured with respect to the AT-MIO-16X ground and can be calculated by the following formula:

$$V_{cm-actual} = \frac{(V_{+in} + V_{-in})}{2}$$

where  $V_{+in}$  is the signal at the positive (+) input of the PGIA and  $V_{-in}$  is the signal at the negative (-) input of the PGIA. Both  $V_{+in}$  and  $V_{-in}$  are measured with respect to AI GND.

## Analog Output Signal Connections

DAC0 OUT is the voltage output signal for analog output Channel 0.  
DAC1 OUT is the voltage output signal for analog output Channel 1.

EXTREF is the external reference input for both analog output channels. Each analog output channel must be configured individually for external reference selection in order for the signal applied at the external reference input to be used by that channel. Analog output configuration instructions are in the *Analog Output Configuration* section earlier in this chapter.

The following ranges and ratings apply to the EXTREF input:

- Normal input voltage range  $\pm 10$  V peak with respect to AO GND
- Usable input voltage range  $\pm 18$  V peak with respect to AO GND
- Absolute maximum ratings  $\pm 30$  V peak with respect to AO GND

AO GND is the ground reference point for both analog output channels and for the external reference signal.

Figure 2-11 shows how to make analog output connections and the external reference input connection to the AT-MIO-16X board.

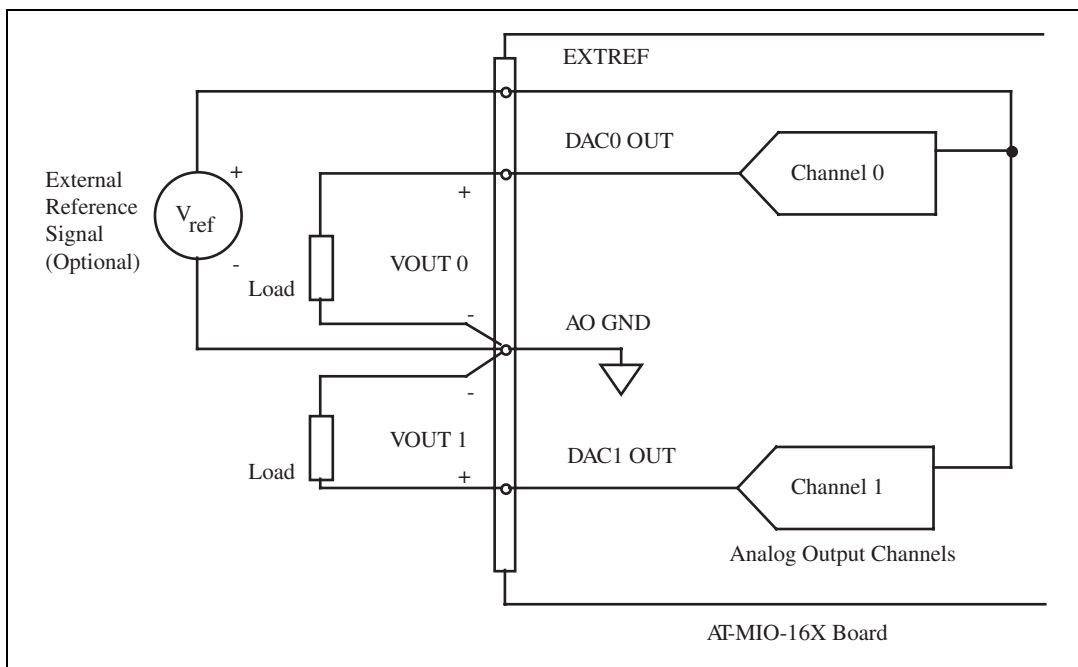

**Figure 2-11.** Analog Output Connections

The external reference signal can be either a DC or an AC signal. This reference signal is multiplied by the DAC code to generate the output voltage.

## Digital I/O Signal Connections

The digital lines ADIO<0..3> are connected to digital I/O port A. The digital lines BDIO<0..3> are connected to digital I/O port B. DIG GND is the digital ground pin for both digital I/O ports. Ports A and B can be programmed individually to be inputs or outputs.

The following specifications and ratings apply to the digital I/O lines.

Absolute maximum voltage input rating    5.5 V with respect to  
DIG GND

Digital input specifications (referenced to DIG GND):

$V_{IH}$ input logic high voltage	2 V minimum
$V_{IL}$ input logic low voltage	0.8 V maximum
$I_{IH}$ input current load, logic high input voltage	40 $\mu$ A maximum
$I_{IL}$ input current load, logic low input voltage	-120 $\mu$ A maximum

Digital output specifications (referenced to DIG GND):

$V_{OH}$ output logic high voltage	2.4 V minimum
$V_{OL}$ output logic low voltage	0.5 V maximum
$I_{OH}$ output source current, logic high	2.6 mA maximum
$I_{OL}$ output sink current, logic low	24 mA maximum

With these specifications, each digital output line can drive 11 standard TTL loads and over 50 LS TTL loads.

Figure 2-12 depicts signal connections for three typical digital I/O applications.

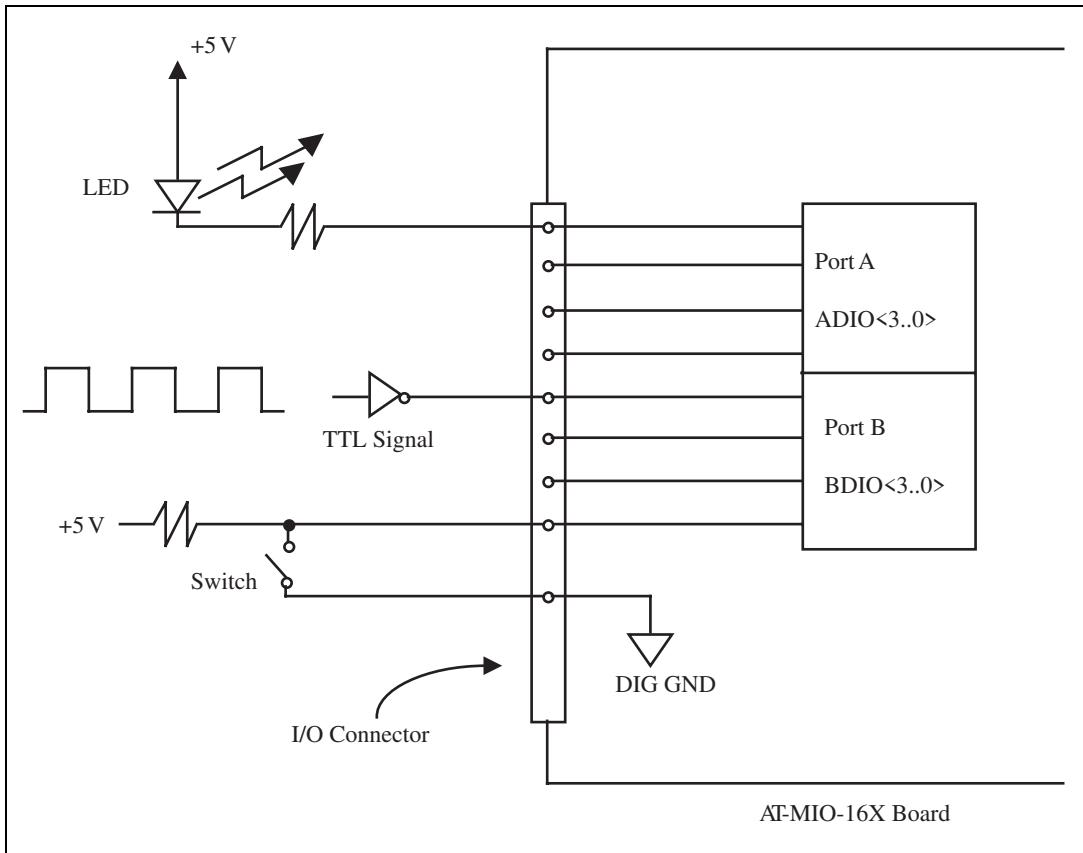

**Figure 2-12.** Digital I/O Connections

In Figure 2-12, port A is configured for digital output, and port B is configured for digital input. Digital input applications include receiving TTL signals and sensing external device states such as the state of the switch in Figure 2-12. Digital output applications include sending TTL signals and driving external devices such as the LED shown in Figure 2-12.

## Power Connections

The I/O connector provides +5 V from the PC power supply. This +5 V is referenced to DIG GND and can be used to power external digital circuitry.

Power rating            1.0 A at +5 V  $\pm$ 10 %, fused



**Caution:** *Under no circumstances should these +5-V power pins be directly connected to analog or digital ground or to any other voltage source on the AT-MIO-16X or any other device. Doing so can damage the AT-MIO-16X and the PC. National Instruments is not liable for damages resulting from such a connection.*

## Timing Connections for Data Acquisition and Analog Output

The data acquisition and analog output timing signals are SCANCLK, EXTSTROBE\*, EXTCONV\*, EXTTRIG\*, EXTGATE\*, and EXTTMRTRIG\*.

### SCANCLK Signal

SCANCLK is an output signal that generates a low-to-high edge whenever an A/D conversion begins. SCANCLK pulses only when scanning is enabled on the AT-MIO-16X. SCANCLK is normally low and pulses high for approximately 8 conversion begins. The low-to-high edge can be used to clock external analog input multiplexers. The SCANCLK signal is driven by one CMOS TTL gate.

### EXTSTROBE\* Signal

A low pulse of no less than 500 ns is generated on the EXTSTROBE\* pin when the External Strobe Register is accessed. See the *External Strobe Register* section in Chapter 4, *Register Map and Descriptions*, for more information. Figure 2-13 shows the timing for the EXTSTROBE\* signal.

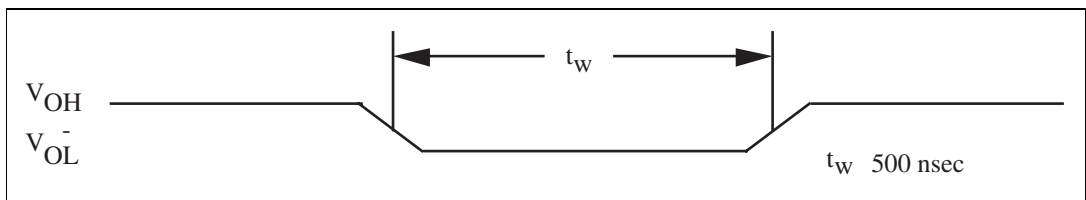

**Figure 2-13.** EXTSTROBE\* Signal Timing

The pulse width is defined as 500 ns minimum. The EXTSTROBE\* signal can be used by an external device to latch signals or trigger events. The EXTSTROBE\* signal is an HCT signal.



## EXTCONV\* Signal

A/D conversions can be externally triggered with the EXTCONV\* pin. Applying an active low pulse to the EXTCONV\* signal initiates an A/D conversion. Figure 2-14 shows the timing requirements for the EXTCONV\* signal.

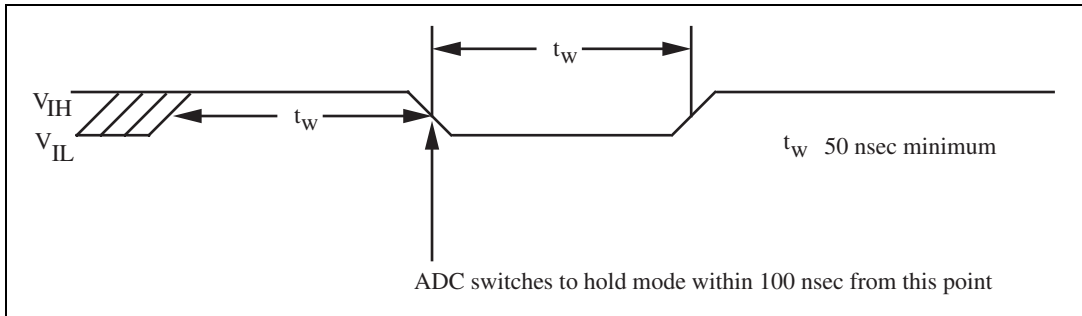

**Figure 2-14.** EXTCONV\* Signal Timing

The minimum allowed pulse width is 50 ns. The ADC switches to hold mode within 100 ns of the high-to-low edge. This hold mode delay time is a function of temperature and does not vary from one conversion to the next. There is no maximum pulse width limitation. EXTCONV\* should be high for at least one conversion period before going low. The EXTCONV\* signal is one HCT load and is pulled up to +5 V through a 10-k $\Omega$  resistor.

EXTCONV\* is also driven by the output of Counter 3 of the Am9513A Counter/Timer. This counter is also referred to as the sample-interval counter. The output of Counter 3 and the RTSI connection to EXTCONV\* must be disabled to a high-impedance state if A/D conversions are to be controlled by pulses applied to the EXTCONV\* pin. If Counter 3 is used to control A/D conversions, its output signal can be monitored at the EXTCONV\* pin.

A/D conversions generated by either the EXTCONV\* signal or the sample-interval counter are inhibited outside of a data acquisition sequence and when gated by either the hardware (EXTGATE\*) signal or software command register gate.



**Note:**

***EXTCONV\* and the output of Counter 3 of the Am9513A are physically connected together on the AT-MIO-16X. If Counter 3 is used in an application, the EXTCONV\* signal must be left undriven. Conversely, if EXTCONV\* is used in an application, Counter 3 must be disabled.***

## EXTTRIG\* Signal

Any data acquisition sequence can be initiated by an external trigger applied to the EXTTRIG\* pin. Applying a falling edge to the EXTTRIG\* pin starts the sample and sample-interval counters, thereby initiating a data acquisition sequence. Figure 2-15 shows the timing requirements for the EXTTRIG\* signal.

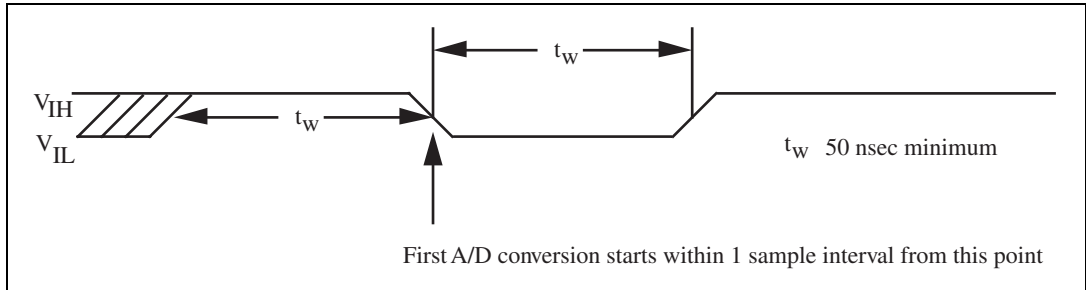

**Figure 2-15.** EXTTRIG\* Signal Timing

The EXTTRIG\* pin is also used to initiate AT-MIO-16X pretriggered data acquisition operations. In pretriggered mode, data is acquired after the first falling edge trigger is received, but no sample counting occurs until after a second falling edge trigger is applied to the EXTTRIG\* pin. The acquisition then completes when the sample counter decrements to zero. This mode acquires data both before and after a hardware trigger is received.

The minimum pulse width allowed is 50 ns. The first A/D conversion starts within one sample interval from the high-to-low edge. The sample interval is controlled by Counter 3 or EXTCONV\*. There is no maximum pulse width limitation; however, EXTTRIG\* should be high for at least 50 ns before going low. The EXTTRIG\* signal is one HCT load and is pulled up to +5 V through a 10-k $\Omega$  resistor.

The EXTTRIG\* signal is logically ANDed with the internal DAQSTART signal. If a data acquisition sequence is to be initiated with an internal trigger, EXTTRIG\* must be high at both the I/O connector and the RTSI switch. If EXTTRIG\* is low, the sequence will not be triggered. In addition, triggers from the EXTTRIG\* signal can be inhibited through programming of a register in the AT-MIO-16X register set.

## EXTGATE\* Signal

EXTGATE\* is an input signal used for hardware gating. EXTGATE\* controls A/D conversion pulses. If EXTGATE\* is low, no A/D conversion pulses occur from EXTCONV\* or the sample-interval counter. If EXTGATE\* is high, conversions take place if programmed and otherwise enabled.

## EXTTMRTRIG\* Signal

The analog output DACs on the AT-MIO-16X can be updated using either internal or external signals in posted update mode. The DACs can be updated externally by using the EXTTMRTRIG\* signal from the I/O connector. This signal updates the DACs when A4RCV is disabled and the appropriate DAC waveform mode is programmed through one of the registers in the AT-MIO-16X register set.

The analog output DACs are updated by the high-to-low edge of the applied pulse. Figure 2-16 shows the timing requirements for the EXTTMRTRIG\* signal.

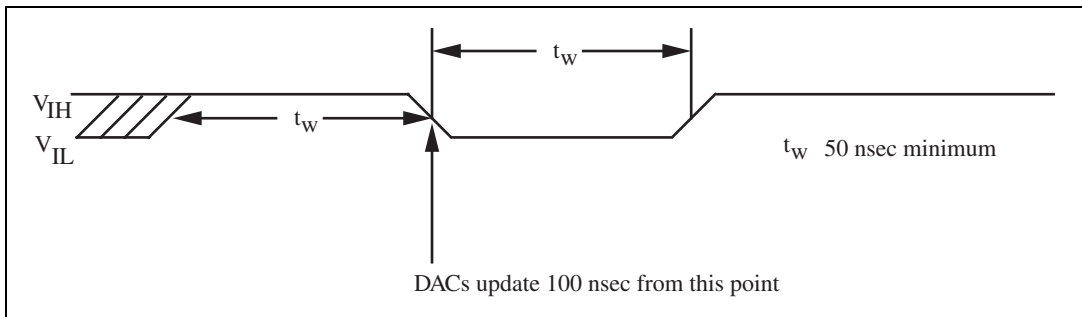

**Figure 2-16.** EXTTMRTRIG\* Signal Timing

The minimum pulse width allowed is 50 ns. The DACs are updated within 100 ns of the high-to-low edge. There is no maximum pulse width limitation. EXTTMRTRIG\* should be high for at least 50 ns before going low. The EXTTMRTRIG\* signal is one HCT load and is pulled up to +5 V through a 10-k $\Omega$  resistor.

## Counter Signal Connections

The general-purpose timing signals include the GATE and OUT signals for the Am9513A Counters 1, 2, and 5, SOURCE signals for Counters 1 and 5, and the FOUT signal generated by the Am9513A. Counters 1, 2, and 5 of the Am9513A Counter/Timer can be used for general-purpose applications, such as pulse and square wave generation, event counting, pulse-width, time-lapse, and frequency measurements. For these applications, SOURCE and GATE signals can be directly applied to the counters from the I/O connector. The counters are programmed for various operations.

The Am9513A Counter/Timer is described briefly in Chapter 3, *Theory of Operation*. For detailed programming information, consult Appendix C, *AMD Am9513A Data Sheet*. For detailed applications information, consult the *Am9513A/Am9513 System Timing Controller* technical manual published by Advanced Micro Devices, Inc.

Pulses and square waves can be produced by programming Counter 1, 2, or 5 to generate a pulse signal at its OUT output pin or to toggle the OUT signal each time the counter reaches the terminal count.

For event counting, one of the counters is programmed to count rising or falling edges applied to any of the Am9513A SOURCE inputs. The counter value can then be read to determine the number of edges that have occurred. Counter operation can be gated on and off during event counting.

Figure 2-17 shows connections for a typical event-counting operation in which a switch is used to gate the counter on and off.

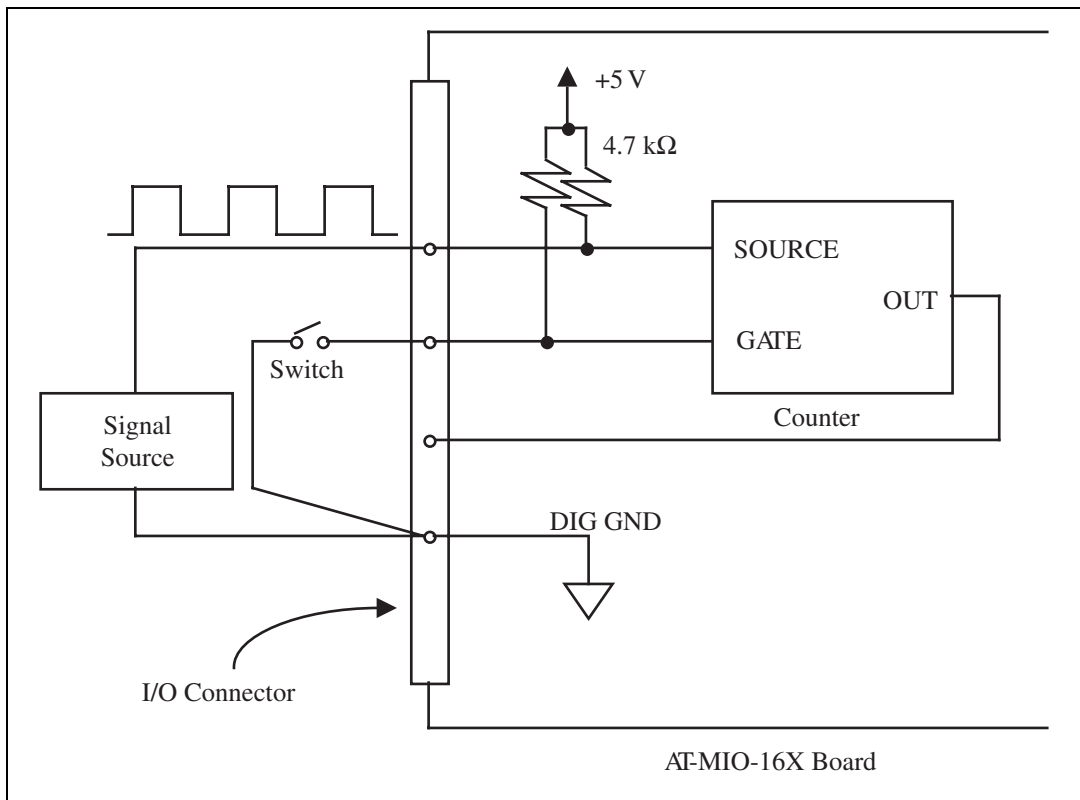
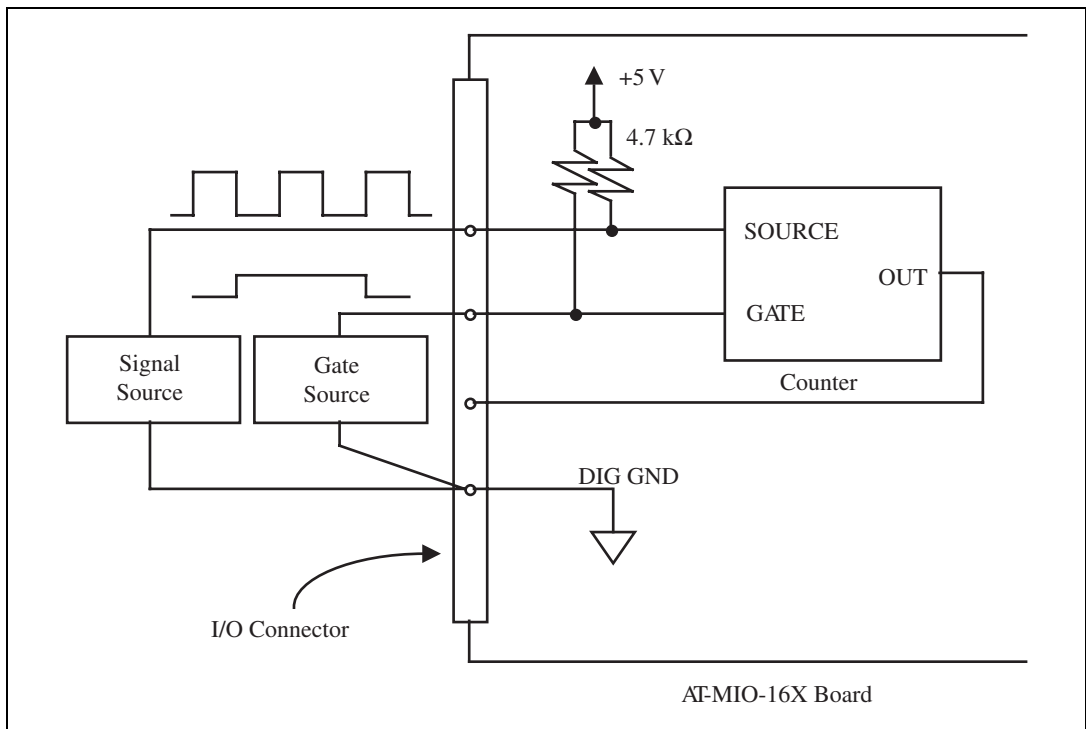

**Figure 2-17.** Event-Counting Application with External Switch Gating

To perform pulse-width measurement, a counter is programmed to be level gated. The pulse to be measured is applied to the counter GATE input. The counter is programmed to count while the signal at the GATE input is either high or low. If the counter is programmed to count an internal timebase, then the pulse width is equal to the counter value multiplied by the timebase period.

For time-lapse measurement, a counter is programmed to be edge gated. An edge is applied to the counter GATE input to start the counter. The counter can be programmed to start counting after receiving either a high-to-low edge or a low-to-high edge. If the counter is programmed to count an internal timebase, then the time lapse since receiving the edge is equal to the counter value multiplied by the timebase period.

To measure frequency, a counter is programmed to be level gated and the rising or falling edges are counted in a signal applied to a SOURCE input. The gate signal applied to the counter GATE input is of some known duration. In this case, the counter is programmed to count either rising or falling edges at the SOURCE input while the gate is applied. The frequency of the input signal is then the count value divided by the known gate period. Figure 2-18 shows the connections for a frequency measurement application. A second counter can also be used to generate the gate signal in this application.



**Figure 2-18.** Frequency Measurement Application

Two or more counters can be concatenated by tying the OUT signal from one counter to the SOURCE signal of another counter. The counters can then be treated as one 32-bit or 48-bit counter for most counting applications.

The signals for Counters 1, 2, and 5, and the FOUT output signal are directly tied from the Am9513A input and output pins to the I/O connector. In addition, the GATE, SOURCE, and OUT1 pins are pulled up to +5 V through a 4.7-k $\Omega$  resistor. The input and output ratings and timing specifications for the Am9513A signals are given as follows:

Absolute maximum voltage input rating     $-0.5$  V to  $+7.0$  V with respect to DIG GND

Am9513A digital input specifications (referenced to DIG GND):

$V_{IH}$ input logic high voltage	2.2 V minimum
$V_{IL}$ input logic low voltage	0.8 V maximum
Input load current	$\pm 10$ $\mu$ A maximum

Am9513A digital output specifications (referenced to DIG GND):

$V_{OH}$ output logic high voltage	2.4 V minimum
$V_{OL}$ output logic low voltage	0.4 V maximum
$I_{OH}$ output source current, at $V_{OH}$	200 $\mu$ A maximum
$I_{OL}$ output sink current, at $V_{OL}$	3.2 mA maximum
Output current, high-impedance state	$\pm 25$ $\mu$ A maximum

Figure 2-19 shows the timing requirements for the GATE and SOURCE input signals and the timing specifications for the OUT output signals of the Am9513A.

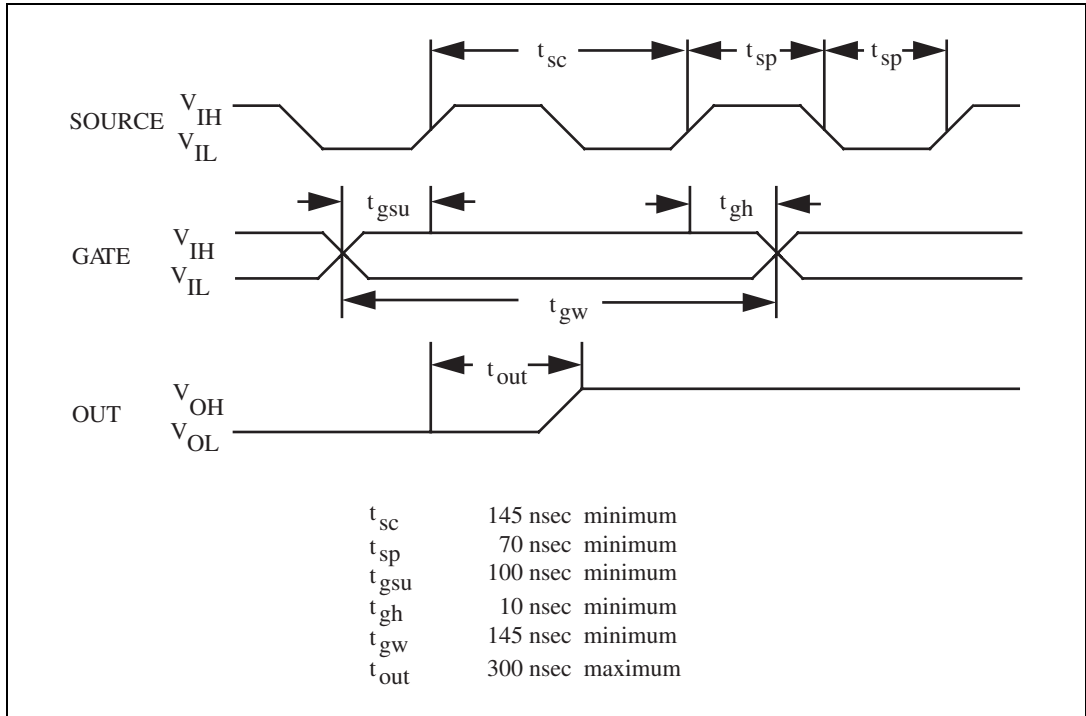

**Figure 2-19.** General-Purpose Timing Signals

The GATE and OUT signal transitions in Figure 2-17 are referenced to the rising edge of the SOURCE signal. This timing diagram assumes that the counters are programmed to count rising edges. The same timing diagram, with the source signal inverted and referenced to the falling edge of the source signal, applies to the case in which the counter is programmed to count falling edges.

The signal applied at a SOURCE input can be used as a clock source by any of the Am9513A counter/timers and by the Am9513A frequency division output FOUT. The signal applied to a SOURCE input must not exceed a frequency of 6 MHz for proper operation of the Am9513A. The Am9513A counters can be individually programmed to count rising or falling edges of signals applied at any of the Am9513A SOURCE or GATE input pins.

In addition to the signals applied to the SOURCE and GATE inputs, the Am9513A generates six internal timebase clocks from the clock signal supplied by the AT-MIO-16X. The base clock signal is selected by a



register in the AT-MIO-16X register set and then divided by 10. The default value is 1 MHz into the Am9513A (10-MHz clock signal on the AT-MIO-16X). The six internal timebase clocks can be used as counting sources, and these clocks have a maximum skew of 75 nsec between them. The SOURCE signal shown in Figure 2-19 represents any of the signals applied at the SOURCE inputs, GATE inputs, or internal timebase clocks. See Appendix C, *AMD Am9513A Data Sheet*, for further details.

Specifications for signals at the GATE input are referenced to the signal at the SOURCE input or one of the Am9513A internally generated signals. Figure 2-19 shows the GATE signal referenced to the rising edge of a source signal. The gate must be valid (either high or low) at least 100 nsec before the rising or falling edge of a source signal for the gate to take effect at that source edge as shown by  $t_{gsu}$  and  $t_{gh}$  in Figure 2-19. Similarly, the gate signal must be held for at least 10 nsec after the rising or falling edge of a source signal for the gate to take effect at that source edge. The gate high or low period must be at least 145 nsec in duration. If an internal timebase clock is used, the gate signal cannot be synchronized with the clock. In this case, gates applied close to a source edge take effect either on that source edge or on the next one. This arrangement results in an uncertainty of one source clock period with respect to unsynchronized gating sources.

Signals generated at the OUT output are referenced to the signal at the SOURCE input or to one of the Am9513A internally generated clock signals. Figure 2-19 shows the OUT signal referenced to the rising edge of a source signal. Any OUT signal state changes occur within 300 nsec after the source signal rising or falling edge.

## Field Wiring Considerations

---

Accuracy of measurements made with the AT-MIO-16X can be seriously affected by environmental noise if proper considerations are not taken into account when running signal wires between signal sources and the AT-MIO-16X board. The following recommendations apply mainly to analog input signal routing to the AT-MIO-16X board, although they are applicable for signal routing in general.

You can minimize noise pickup and maximize measurement accuracy by doing the following:

- Use differential analog input connections to reject common-mode noise.
- Use individually shielded, twisted-pair wires to connect analog input signals to the AT-MIO-16X. With this type of wire, the signals attached to the CH+ and CH- inputs are twisted together and then covered with a shield. This shield is then connected only at one point to the signal source ground. This kind of connection is required for signals traveling through areas with large magnetic fields or high electromagnetic interference.
- Route signals to the AT-MIO-16X carefully. Keep cabling away from noise sources. The most common noise source in a PC data acquisition system is the video monitor. Separate the monitor from the analog signals as much as possible.

The following recommendations apply for all signal connections to the AT-MIO-16X:

- Separate AT-MIO-16X signal lines from high-current or high-voltage lines. These lines are capable of inducing currents in or voltages on the AT-MIO-16X signal lines if they run in parallel paths at a close distance. Reduce the magnetic coupling between lines by separating them by a reasonable distance if they run in parallel, or by running the lines at right angles to each other.
- Do not run AT-MIO-16X signal lines through conduits that also contain power lines.
- Protect AT-MIO-16X signal lines from magnetic fields caused by electric motors, welding equipment, breakers, or transformers by running the AT-MIO-16X signal lines through special metal conduits.

## Cabling Considerations for the AT-MIO-16X with 50-Pin I/O Connector

---

National Instruments has a cable termination accessory, the CB-50, for use with the AT-MIO-16X board. This kit includes a terminated 50-conductor flat ribbon cable and a connector block. Signal I/O leads can be attached to screw terminals on the connector block and thereby connected to the AT-MIO-16X I/O connector.

The CB-50 is useful for prototyping an application or in situations where AT-MIO-16X interconnections are frequently changed. When you develop a final field wiring scheme, however, you may want to develop your own cable. This section contains information and guidelines for designing custom cables.

In making your own cabling, you may decide to shield your cables. The following guidelines may help:

- For the analog input signals, shielded twisted-pair wires for each analog input pair yield the best results, assuming that differential inputs are used. Tie the shield for each signal pair to the ground reference at the source.
- The analog lines, pins 1 through 23, should be routed separately from the digital lines, pins 24 through 50.
- When using a cable shield, use separate shields for the analog and digital halves of the cable. Failure to do so results in noise from switching digital signals coupling into the analog signals.

## Cabling Considerations for the AT-MIO-16X with 68-Pin I/O Connector

---

National Instruments has a 68-pin mating connector and shell kit you can use with the AT-MIO-16X board. In making your own cabling, you may decide to shield your cables. The following guidelines may help:

- For the analog input signals, shielded twisted-pair wires for each analog input pair yield the best results, assuming that differential inputs are used. Tie the shield for each signal pair to the ground reference at the source.
- If you use a non-shielded cable such as a ribbon cable:
  - Route the analog lines separately from the digital lines.
  - When using a cable shielded, use separate shields for the analog and digital halves of the cable. Failure to do so results in noise from switching digital signals coupling into the analog signals.

# Theory of Operation

This chapter contains a functional overview of the AT-MIO-16X and explains the operation of each functional unit making up the AT-MIO-16X.

## Functional Overview

The block diagram in Figure 3-1 is a functional overview of the AT-MIO-16X board.

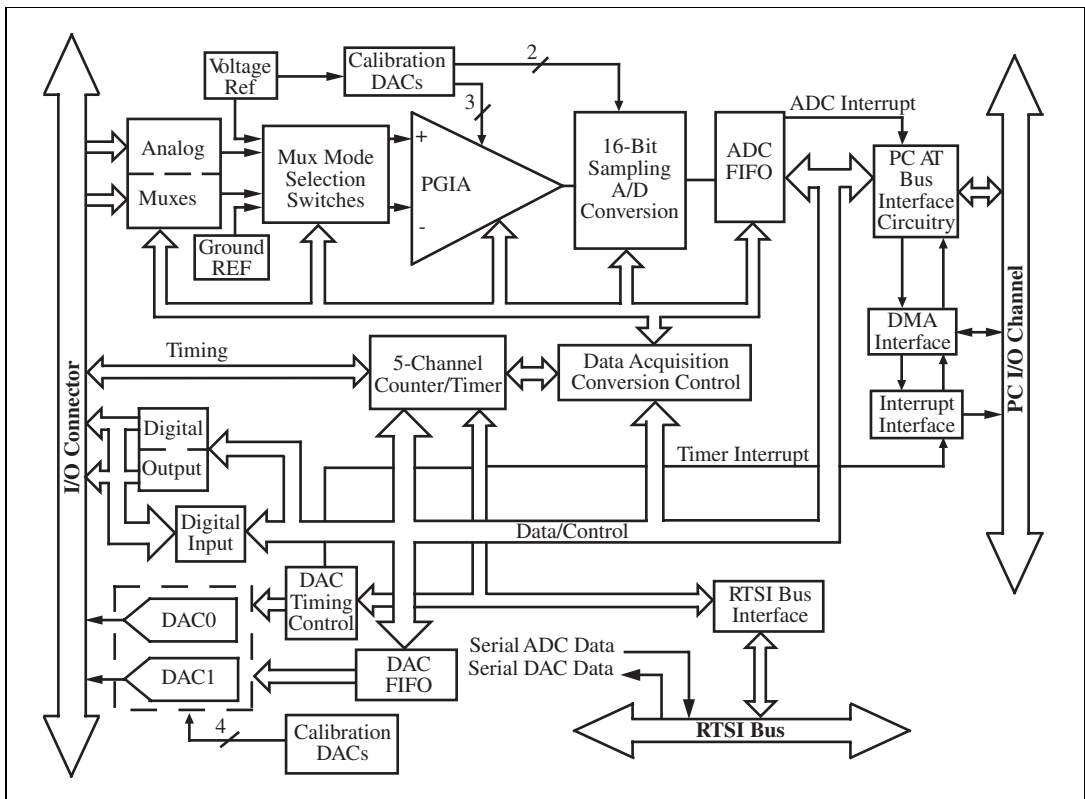

Figure 3-1. AT-MIO-16X Block Diagram

The following major components make up the AT-MIO-16X board:

- PC I/O channel interface circuitry
- Analog input circuitry
- Data acquisition circuitry
- Analog output circuitry
- DAC waveform generation circuitry
- Digital I/O circuitry
- Timing I/O circuitry
- RTSI bus interface circuitry

The internal data and control buses interconnect the components. The theory of operation of each of these components is explained in the remainder of this chapter.

## PC I/O Channel Interface Circuitry

---

The AT-MIO-16X board is a full-size 16-bit PC I/O channel adapter. The PC I/O channel consists of a 24-bit address bus, a 16-bit data bus, a DMA arbitration bus, interrupt lines, and several control and support signals. The components making up the AT-MIO-16X PC I/O channel interface circuitry are shown in Figure 3-2.

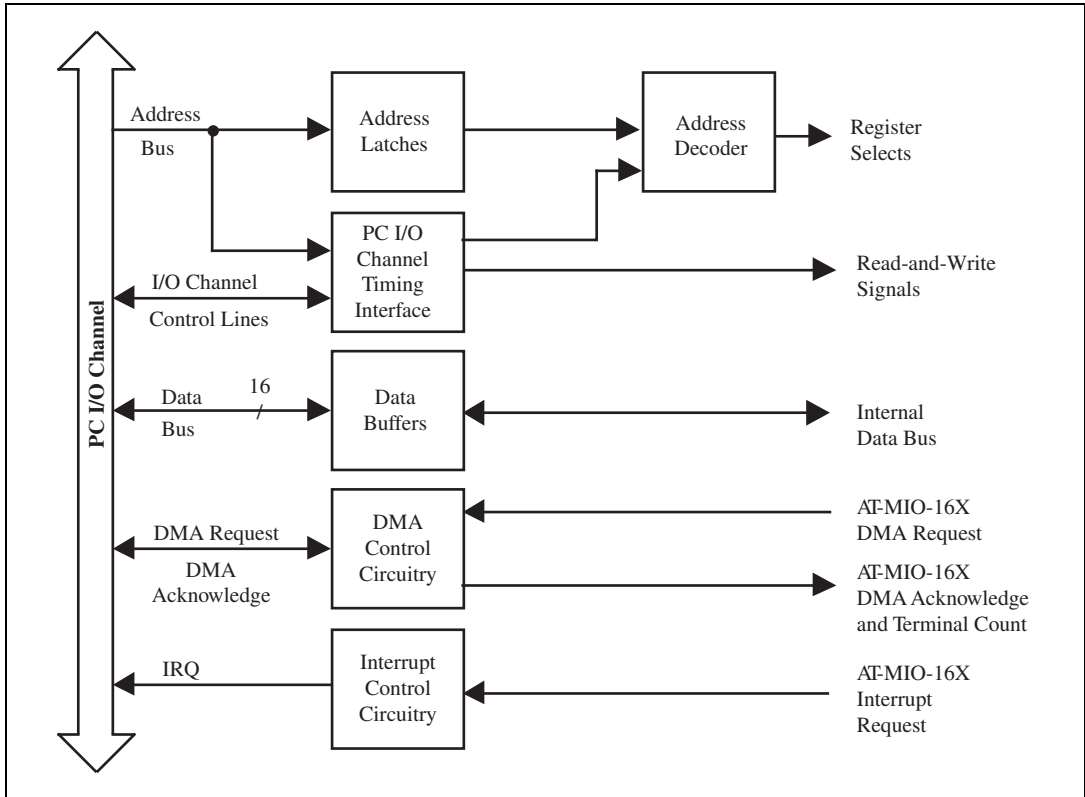

**Figure 3-2.** PC I/O Channel Interface Circuitry Block Diagram

The PC I/O channel interface circuitry consists of address latches, address decoder circuitry, data buffers, PC I/O channel interface timing signals, interrupt circuitry, and DMA arbitration circuitry. The PC I/O channel interface circuitry generates the signals necessary to control and monitor the operation of the AT-MIO-16X multiple-function circuitry.

The PC I/O channel has 24 address lines; the AT-MIO-16X uses 10 of these lines to decode the board address. Therefore, the board address range is 000 to 3FF hex. SA5 through SA9 are used to generate the board enable signal. SA0 through SA4 are used to select individual onboard registers. The address-decoding circuitry generates the register select signals that identify which AT-MIO-16X register is being accessed. The AT-MIO-16X is factory configured for a base address of 220 hex. With this base address, all of the registers on the board will fall into the address range of 220 hex to 23F hex. If this address range

conflicts with any other equipment in your PC, you must change the base address of the AT-MIO-16X or of the other device. See Chapter 2, *Configuration and Installation*, for more information.

The PC I/O channel interface timing signals are used to generate read-and-write signals and to define the transfer cycle size. A transfer cycle can be either an 8-bit or a 16-bit data I/O operation. The AT-MIO-16X returns signals to the PC I/O channel to indicate when the board has been accessed, when the board is ready for another transfer, and the data bit size of the current I/O transfer. Particular attention must be paid to the AT-MIO-16X register sizes. An 8-bit access to a 16-bit location, and vice versa, is invalid and will cause sporadic operation.

The interrupt control circuitry routes any enabled board-level interrupt requests to the selected interrupt request line. The interrupt requests are tristate output signals which allow the AT-MIO-16X board to share the interrupt line with other devices. Eight interrupt request lines are available for use by the AT-MIO-16X: IRQ3, IRQ4, IRQ5, IRQ7, IRQ10, IRQ11, IRQ12, and IRQ15. These interrupt levels are selectable from one of the registers in the AT-MIO-16X register set. Six different interrupts can be generated by the AT-MIO-16X. Each of the following cases is individually enabled and cleared:

- When the ADC FIFO buffer is ready to be serviced
- When a data acquisition operation completes (including an OVERFLOW or OVERRUN error)
- When a DMA terminal count pulse is received on DMA Channel A or DMA Channel B
- When the DAC FIFO buffer is ready to be serviced
- When a DAC sequence completes (including an UNDERFLOW error)
- When a falling edge signal is detected on the DAC update signal (internal or external)

The DMA control circuitry generates DMA requests whenever an A/D measurement is available from the ADC FIFO and when the DAC FIFO is ready to receive more data. The DMA circuitry supports full PC I/O channel 16-bit DMA transfers. DMA Channels 5, 6, and 7 of the PC I/O channel are available for such transfers. DMA Channels 0, 1, 2, and 3 are available for 16-bit transfers on EISA computers only, and not on PC AT and compatible computers. With the DMA circuitry, either single-channel transfer mode or dual-channel transfer mode can be

selected for DMA transfer. These DMA channels are selectable from one of the registers in the AT-MIO-16X register set.

## Analog Input and Data Acquisition Circuitry

The AT-MIO-16X handles 16 channels of analog input with software-programmable configuration and 16-bit A/D conversion. In addition, the AT-MIO-16X contains data acquisition configuration for automatic timing of multiple A/D conversions and includes advanced options such as external triggering, gating, and clocking. Figure 3-3 shows a block diagram of the analog input and data acquisition circuitry.

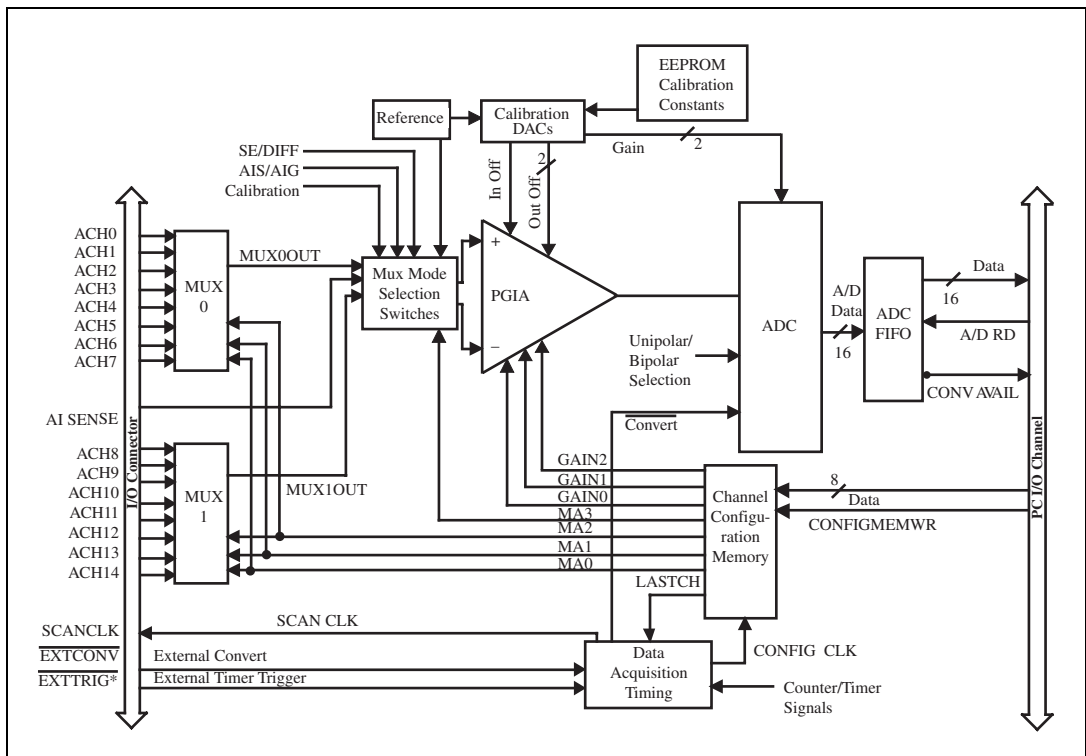

**Figure 3-3.** Analog Input and Data Acquisition Circuitry Block Diagram



## Analog Input Circuitry

The analog input circuitry consists of an input multiplexer, multiplexer-mode selection circuitry, a PGIA, calibration circuitry, a 16-bit sampling ADC, and a 16-bit, 512-word deep FIFO.

### A/D Converter

The ADC is a 16-bit, sampling, successive approximation ADC. With 16-bit resolution, the converter can resolve its input range into 65,536 different steps. This resolution generates a 16-bit digital word that represents the value of the input voltage level with respect to the converter input range. The ADC has two input modes that are software selectable on the AT-MIO-16X board on a per channel basis:  $-10$  to  $+10$  V, or  $0$  to  $+10$  V. The ADC on the AT-MIO-16X is guaranteed to convert at a rate of at least 100 ksamples/sec.

The data format circuitry is software programmable to generate either straight binary numbers or two's complement numbers. In unipolar mode, values returned from the ADC are straight binary and result in a range of  $0$  to  $65,535$ . In bipolar mode, the ADC returns two's complement values, resulting in a range of  $-32,768$  to  $+32,767$ .

### Analog Input Multiplexers

The input multiplexer consists of a dual, eight-to-one CMOS analog input multiplexer preceded by input protection resistors and has 16 analog input channels. Analog input overvoltage protection is  $\pm 25$  V powered on and  $\pm 15$  V powered off. Input signals should be in the range of  $+10$  to  $-10$  V for bipolar operation, and  $0$  to  $+10$  V for unipolar operation. Bipolar or unipolar mode configuration is programmed on a per channel basis and is controlled through one of the registers in the AT-MIO-16X register set.

### Analog Input Configuration

Inputs can be configured for differential or single-ended signals on a per channel basis through a register in the AT-MIO-16X register set. In addition, single-ended inputs can be configured for referenced or nonreferenced signals. In the differential configuration, one of input Channels  $0$  through  $7$  is routed to the positive input of the PGIA, and one of Channels  $8$  through  $15$  is routed to the negative input of the PGIA. In the single-ended configuration, one of input Channels  $0$  through  $15$  is routed to the positive input of the PGIA. The negative

input of the PGIA in single-ended mode is connected to either the input ground or the AI SENSE signal at the I/O connector depending on the nature of the input signals.

## PGIA

The PGIA fulfills two purposes on the AT-MIO-16X board. It converts a differential input signal into a single-ended signal with respect to the AT-MIO-16X ground for input common-mode signal rejection. This conversion allows the input analog signal to be extracted from any common-mode voltage or noise before being sampled and converted. The PGIA also applies gain to the input signal, amplifying an input analog signal before sampling and conversion to increase measurement resolution and accuracy. Software-selectable gains of 1, 2, 5, 10, 20, 50, and 100 are available through the AT-MIO-16X PGIA on a per channel basis.

## ADC FIFO Buffer

When an A/D conversion is complete, the ADC circuitry shifts the result into the ADC FIFO buffer. The FIFO buffer is 16-bits wide and 512-words deep. This FIFO serves as a buffer to the ADC and is beneficial for two reasons. Any time an A/D conversion is complete, the value is saved in the FIFO buffer for later reading, and the ADC is free to start a new conversion. Secondly, the FIFO can collect up to 512 A/D conversion values before any information is lost; thus software or DMA has extra time (512 times the sample interval) to catch up with the hardware. If more than 512 values are stored in the FIFO without the FIFO being read from, an error condition called FIFO overflow occurs and A/D conversion information is lost. When the ADC FIFO contains a single A/D conversion value or more, it can generate a DMA or interrupt request to be serviced.

## Analog Input Calibration

Measurement reliability is assured through the use of the onboard calibration circuitry of the AT-MIO-16X. This circuitry uses a stable, internal, +5 VDC reference that is measured at the factory against a higher accuracy reference; then its value is permanently stored in the EEPROM on the AT-MIO-16X. With this stored reference value, the AT-MIO-16X board can be recalibrated without additional external hardware at any time under any number of different operating conditions in order to remove errors caused by temperature drift and time. The AT-MIO-16X is calibrated at the factory in both unipolar and

bipolar modes, and these values are also permanently stored in the EEPROM. Calibration constants can be read from the EEPROM then written to the calibration DACs that adjust pregain offset, postgain offset, and gain errors associated with the analog input section. There is a 12-bit pregain offset calibration DAC, an 8-bit coarse postgain offset calibration DAC, an 8-bit fine postgain offset calibration DAC, an 8-bit coarse gain calibration DAC, and an 8-bit fine gain calibration DAC. Functions are provided with the board to calibrate the analog input section, access the EEPROM on the board, and write to the calibration DACs. When the AT-MIO-16X leaves the factory, locations 96 through 127 of the EEPROM are protected and cannot be modified. Locations 0 through 95 are unprotected and can be used to store alternate calibration constants for the differing conditions under which the board is used. Refer to Chapter 6, *Calibration Procedures*, for additional calibration information.

## Data Acquisition Timing Circuitry

This section details the different methods of acquiring A/D data from a single channel or multiple channels. Prior to any of these operations, the channel, gain, mode, and range settings must be configured. This is accomplished through writing to a register in the AT-MIO-16X register set.

### Single-Read Timing

The simplest method of acquiring data from the A/D converter is to initiate a single conversion and then read the resulting value from the ADC FIFO buffer after the conversion is complete. A single conversion can be generated three different ways: applying an active low pulse to the EXTCONV\* pin of the I/O connector, generating a falling edge on the sample-interval counter output pin (Counter 3 of the Am9513A Counter/Timer), or strobing the appropriate register in the AT-MIO-16X register set. Any one of these operations will generate the timing shown in Figure 3-4. The ADC\_BUSY\* signal status can be monitored through a status register on the AT-MIO-16X.

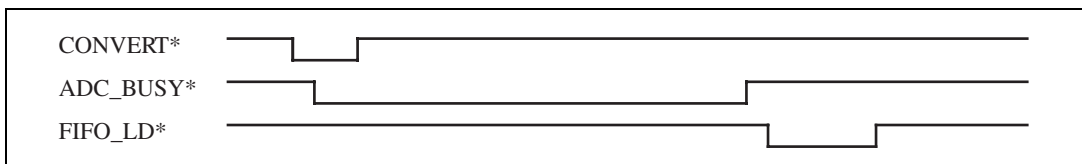

Figure 3-4. ADC Conversion Timing

When the ADC value is shifted into the ADC FIFO buffer by FIFO\_LD\*, a signal is generated that indicates valid data is available to be read. Single conversion timing of this type is appropriate for reading channel data on an ad hoc basis. However, if a sequence of conversions is needed, this method is not very reliable because it relies on the software to generate the conversions in the case of the strobe register. If finely timed conversions are desired that require triggering and gating, then it is necessary to program the board to automatically generate timed signals that initiate and gate conversions. This is known as a data acquisition sequence.

A data acquisition operation refers to the process of taking a sequence of A/D conversions with the sample interval (the time between successive A/D conversions) carefully timed. The data acquisition timing circuitry consists of various clocks and timing signals. Three types of data acquisition are available with the AT-MIO-16X board: single-channel data acquisition, multiple-channel data acquisition with continuous scanning, and multiple-channel data acquisition with interval scanning. All data acquisition operations work with pretrigger and posttrigger modes with either internal or external timing signals. Pretriggering acquires data before a software or hardware trigger is applied. Posttriggering acquires data only after a software or hardware trigger is received.

## Single-Channel Data Acquisition Timing

The sample-interval timer is a 16-bit down counter that can be used with the six internal timebases of the Am9513A to generate sample intervals from 0.4  $\mu$ sec to 6 sec (see the *Timing I/O Circuitry* section later in this chapter). Conversion intervals of less than 10 result in an overrun condition. Counter 3 of the Am9513A Counter/Timer is used to generate conversion interval timing signals. The sample-interval timer can also use any of the external clock inputs to the Am9513A as a timebase. During data acquisition, the sample interval counts down at the rate given by the internal timebase or external clock. Each time the sample-interval timer reaches zero, it generates an active low pulse and reloads with the programmed sample-interval count, initiating a conversion. This operation continues until data acquisition halts.

External control of the sample interval is possible by applying a stream of pulses at the EXTCONV\* input. In this case, you have complete external control over the sample interval and the number of A/D conversions performed. All data acquisition operations are functional with external signals to control conversions. This means that in a data

acquisition sequence that employs external conversion timing, conversions are inhibited by the hardware until a trigger condition is received, then the programmed number of conversions occurs, and conversions are inhibited after the sequence completes. When using internal timing, the EXTCONV\* signal at the I/O connector must be left unconnected or in the high-impedance state.

Data acquisition can be controlled by the onboard sample counter. This counter is loaded with the number of posttrigger samples to be taken during a data acquisition operation. The sample counter can be 16-bit for counts up to 65,535 or 32-bit for counts up to  $2^{32} - 1$ . If a 16-bit counter is needed, Counter 4 of the Am9513A Counter/Timer is used. If more than 16-bits are needed, Counter 4 is concatenated with Counter 5 of the Am9513A to form a 32-bit counter. The sample counter decrements its count each time the sample-interval counter generates an A/D conversion pulse, and the sample counter stops the data acquisition process when it counts down to zero. The sample counter can also be used to count conversions generated by external conversion signals.

The configuration memory register is set up to select the analog input channel and configuration before data acquisition is initiated for a single-channel data acquisition sequence. These settings remain constant during the entire data acquisition process; therefore, all A/D conversions are performed on a single channel. Single-channel acquisition is enabled through a register in the AT-MIO-16X register set. The data acquisition process can be initiated via software or by applying an active low pulse to the EXTTRIG\* input on the AT-MIO-16X I/O connector. Figure 3-5 shows the timing of a typical single-channel data acquisition sequence.

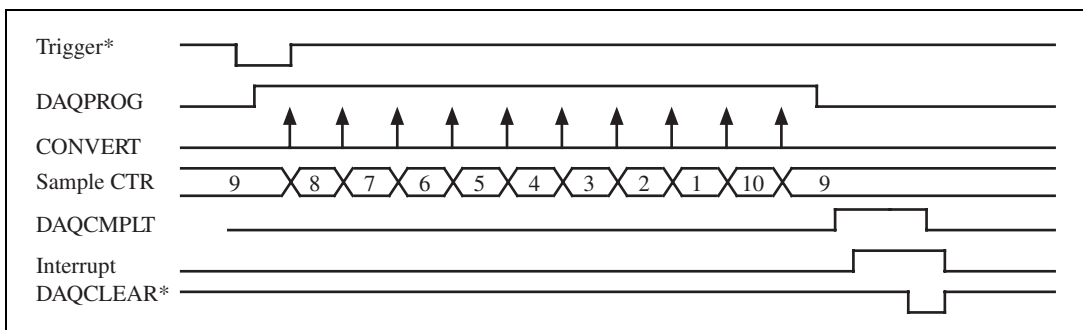

**Figure 3-5.** Single-Channel Posttrigger Data Acquisition Timing

In this sequence, the sample-interval counter, Counter 3, is programmed to generate conversion signals only under a certain gating signal, such as the DAQPROG signal. In addition, the sample counter, Counter 4, is programmed to count the number of conversions generated. In this case, the sample counter is programmed to count 10 samples, then stop the acquisition sequence. A signal is generated at the end of the sequence to indicate its completion. An interrupt request can be generated from this signal if desired. Because the sample counter begins counting immediately after the application of the trigger, this is a posttrigger sequence. If samples are necessary before and after the trigger, then a pretrigger sequence is needed. This sequence is described in the following paragraphs.

Figure 3-6 depicts a pretrigger data acquisition sequence. It is called a pretrigger sequence because the first trigger initiates the sample-interval timer without enabling the sample counter. Conversions occur after this initial trigger and are stored in the ADC FIFO for later retrieval in the same way they are for a posttrigger sequence. After a second trigger is received, the sample counter begins counting conversions. In this example, there are three pretrigger samples, and seven posttrigger samples. Only the number of posttrigger samples is programmable.

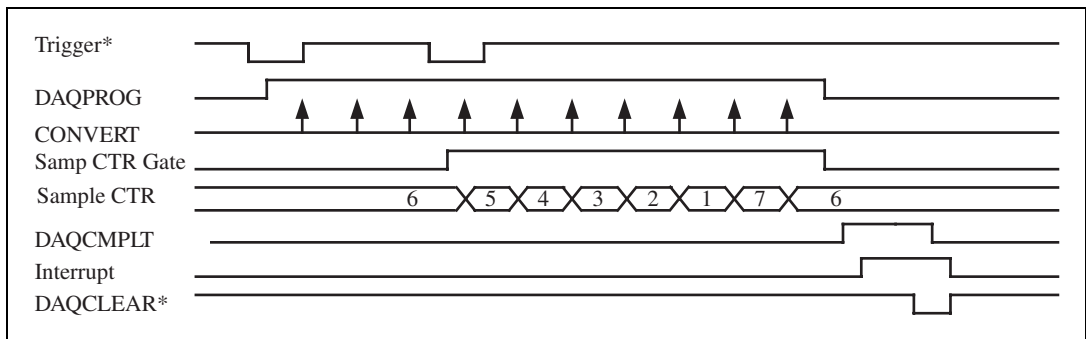

**Figure 3-6.** Single-Channel Pretrigger Data Acquisition Timing

The pretrigger sequence is programmed in much the same way as a posttrigger sequence. The sample-interval timer is programmed to generate conversion pulses under a gate signal, and the sample counter is programmed to count the number of conversions. The only difference between pretrigger and posttrigger sequences for all data acquisition modes is that the sample counter waits for a gating signal in the pretrigger mode before beginning the count. For posttrigger sequences,

the sample timer is independent of the gating signal, and for pretrigger sequences, the sample timer is dependent on the gating signal.

## Multiple-Channel Data Acquisition

Multiple-channel data acquisition is performed by enabling scanning during data acquisition. Multiple-channel scanning is controlled by the configuration memory register.

The configuration memory register consists of 512 words of memory. Each word of memory contains a multiplexer address for input analog channel selection, a gain setting, a mode setting (single-ended or differential), and a range setting (unipolar or bipolar). Each word of memory also contains a bit for synchronizing scanning sequences of different rates, a bit enabling serial data transmission of channel conversion data over the RTSI bus to the AT-DSP2200 digital signal processing board, and a bit indicating if the entry is the last in the scan sequence. In interval scanning, a scan list can consist of any number of scan sequences. Whenever a configuration memory location is selected, the information bits contained in that memory location are applied to the analog input circuitry. For scanning operations, a counter steps through successive locations in the configuration memory at a rate determined by the scan clock. With the configuration memory, therefore, an arbitrary sequence of channels with separate gain, mode, and range settings for each channel can be clocked through during a scanning operation.

A SCANCLK signal is generated from the sample-interval counter. This signal pulses once at the beginning of each A/D conversion and is supplied at the I/O connector. During multiple-channel scanning, the configuration memory location pointer is incremented repeatedly, thereby sequencing through the memory and automatically selecting new channel settings during data acquisition. The signal used to increment the configuration memory location pointer is generated from the SCANCLK signal. Incrementing can be identical to SCANCLK, sequencing the configuration memory location pointer once after every A/D conversion, or it can also be generated by dividing SCANCLK by Counter 1 of the Am9513A Counter/Timer. With this method, the location pointer can be incremented once every  $N$  A/D conversions so that  $N$  conversions can be performed on a single-channel configuration selection before switching to the next configuration memory selection.

## Continuous Scanning Data Acquisition Timing

Continuous scanning data acquisition uses the configuration memory register to automatically sequence from one analog input channel setting to another during the data acquisition sequence. Continuous scanning cycles through the configuration memory without any delays between cycles. Scanning is similar to the single-channel acquisition in the programming of both the sample-interval counter and the sample counter. Scanning data acquisition is enabled through a register in the AT-MIO-16X register set. Figure 3-7 shows the timing for a continuous scanning data acquisition sequence.

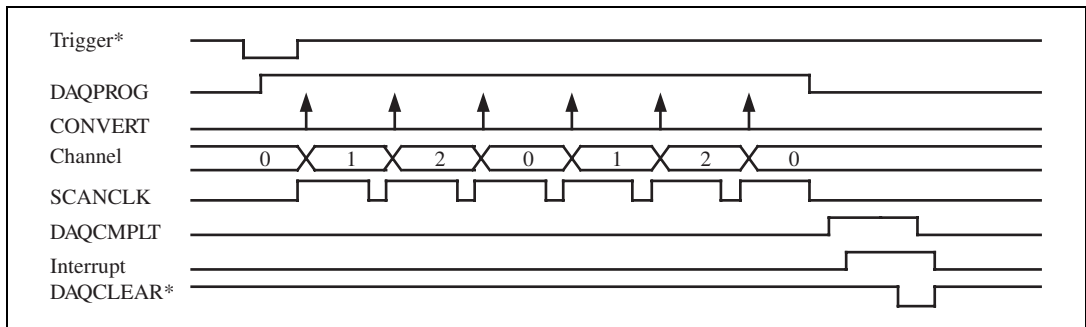

**Figure 3-7.** Scanning Posttrigger Data Acquisition Timing

In this sequence, the timing is the same as the single-channel acquisition except for the addition of the channel sequencing and the generation of the SCANCLK signal. The first sampled channel is Channel 0, followed in time by Channel 1, and finally Channel 2. After this, the sequence is repeated. For this example, the sequence consists of Channels 0, 1, and 2 which are cycled through twice to generate six values of conversion data. After the six samples have been acquired, the sample counter terminates the data acquisition sequence.

The SCANCLK signal is generated to indicate when the input signal can be removed from the conversion channel. This signal is available at the I/O connector and can be used to control external multiplexers for higher channel-count applications. The rising edge of SCANCLK signals when the ADC has acquired the input signal and no longer needs to have it held available. In the scanning acquisition modes, this signal pulses for every conversion.



## Interval Scanning Data Acquisition Timing

Interval scanning assigns a time between the beginning of consecutive scan sequences. If only one scan sequence is in the configuration memory list, the circuitry stops at the end of the list and waits the necessary interval time before starting the scan sequence again. If multiple scan sequences are in the configuration memory list, the circuitry stops at the end of each scan sequence and waits the necessary time interval before starting the next scan sequence. When the end of the scan list is reached, the circuitry stops and waits the necessary time interval before sequencing through the channel information list again. Figure 3-8 shows an example of the interval scanning sequence timing.

Figure 3-8 shows an example of the interval scanning sequence timing.

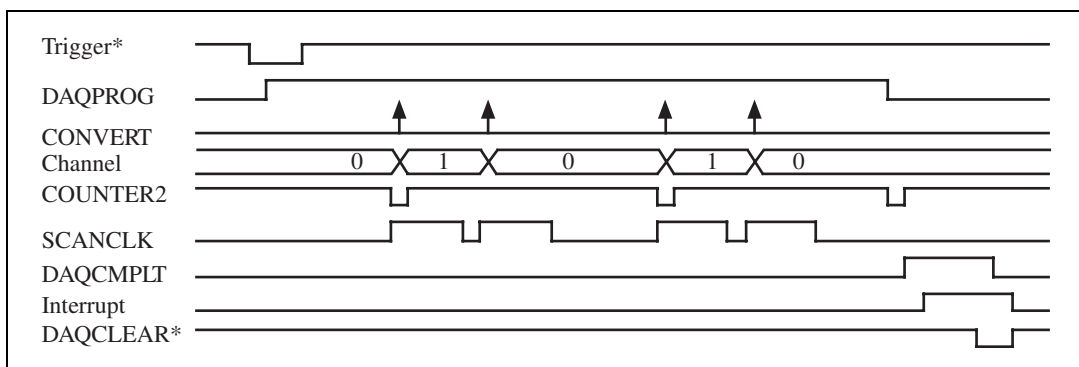

**Figure 3-8.** Interval Scanning Posttrigger Data Acquisition Timing

In interval-scanning applications, the first sample does not occur until after the first falling edge of the Counter 2 output, or one scan interval after the trigger. Scanning stops at the end of the first scan sequence or at the end of the entire scan list. The sequence restarts after a rising edge on Counter 2 is detected. The interval-scanning mode is useful for applications where a number of channels need to be monitored over a long period of time. Interval-scanning monitors the N channels every scan interval, so the effective channel conversion interval is equal to the interval between scans.

## Data Acquisition Rates

The acquisition and channel selection hardware function so that in the channel scanning mode, the next channel in the channel configuration register is selected immediately after the conversion process has begun on the previous channel. With this method, the input multiplexers and the PGIA begin to settle to the new value while the conversion of the last value is still taking place. However, the circuitry does not always settle to full 16-bit accuracy within the smallest allowed sample period of 10  $\mu$ sec. Appendix A, *Specifications*, for specification of settling times for the AT-MIO-16X in scanning modes.

## Analog Output and Timing Circuitry

The AT-MIO-16X has two channels of 16-bit D/A output. Unipolar or bipolar output and internal or external reference voltage selection are available with each analog output channel through a register in the AT-MIO-16X register set. Figure 3-9 shows a block diagram of the analog output circuitry.

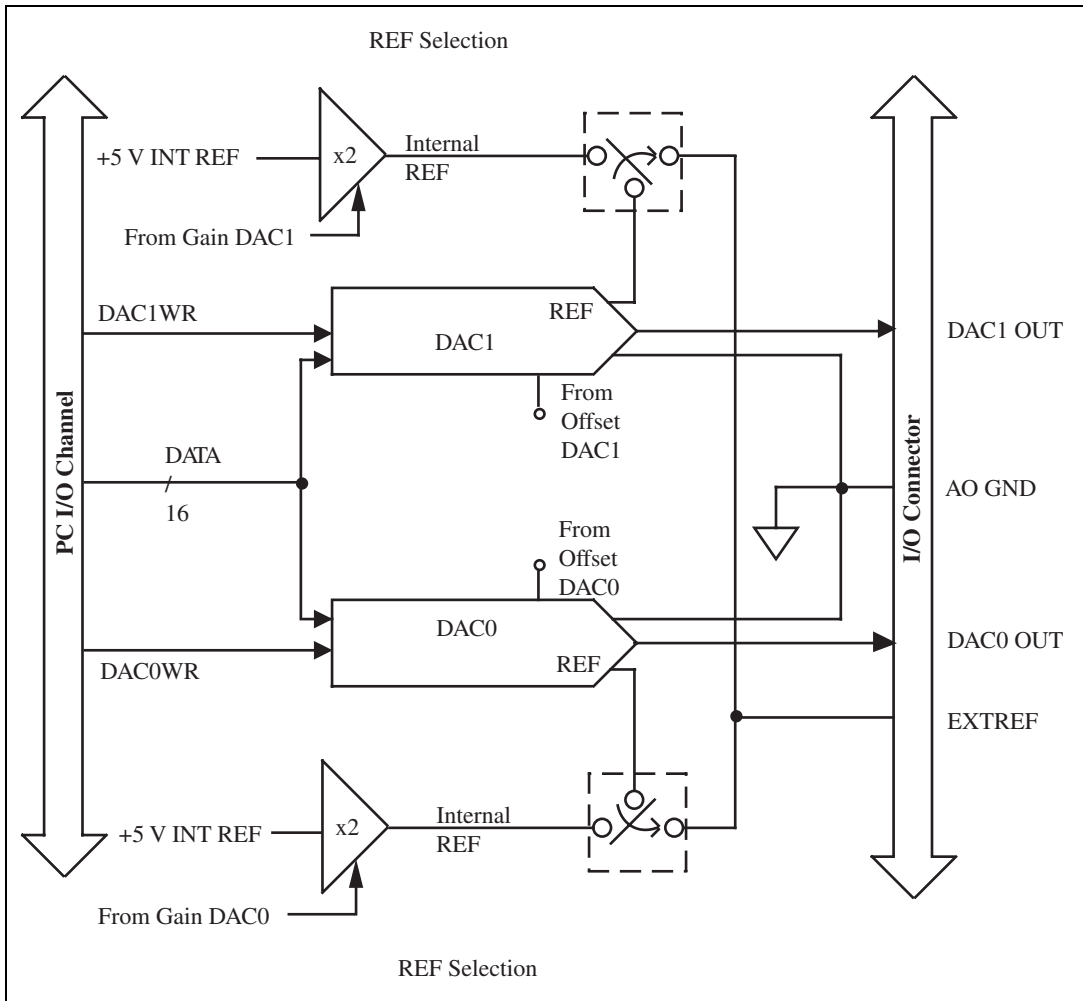

Figure 3-9. Analog Output Circuitry Block Diagram

## Analog Output Circuitry

Each analog output channel contains a 16-bit DAC, reference selection switches, unipolar/bipolar output selection switches, and output data coding circuitry.

The DAC in each analog output channel generates a voltage proportional to the input voltage reference ( $V_{ref}$ ) multiplied by the digital code loaded into the DAC. Each DAC can be loaded with a 16-bit digital code by writing to registers on the AT-MIO-16X board.

The output voltage is available on the AT-MIO-16X I/O connector DAC0 OUT and DAC1 OUT pins. The analog output of the DACs is updated to reflect the loaded 16-bit digital code in one of the following three ways:

- Immediately when the 16-bit code is written to the DACs (in immediate update mode)
- When an active low pulse is detected on the TMRTRIG\* signal (in posted update mode)
- When the Update Register is strobed (in posted update mode)

## Analog Output Configuration

The DAC output op-amps can be configured through one of the AT-MIO-16X registers to generate either a unipolar voltage output or a bipolar voltage output range. A unipolar output has an output voltage range of 0 to  $+V_{\text{ref}} - 1 \text{ LSB V}$  and accepts straight binary input values. A bipolar output has an output voltage range of  $-V_{\text{ref}}$  to  $+V_{\text{ref}} - 1 \text{ LSB V}$  and accepts two's complement input values. One LSB is the voltage increment corresponding to an LSB change in the digital code word. For unipolar output,  $1 \text{ LSB} = (V_{\text{ref}})/65,536$ . For bipolar output,  $1 \text{ LSB} = (V_{\text{ref}})/32,768$ .

The voltage reference source for each DAC is selectable through one of the AT-MIO-16X registers and can be supplied either externally at the EXTREF input or internally. The external reference can be either a DC or an AC signal. If an AC reference is applied, the analog output channel acts as a signal attenuator, and the AC signal appears at the output attenuated by the digital code divided by 65,536 for unipolar output or 32,768 for bipolar output. The internal reference is a 5-V reference multiplied by 2. Using the internal reference supplies an output voltage range of 0 to 9.999847 V in steps of 152.6  $\mu\text{V}$  for unipolar output and an output voltage range of -10 to +9.999695 V in steps of 305.2  $\mu\text{V}$  for bipolar output. Gain calibration for the DACs applies only to the internal reference, not the external reference. Offset calibration can be applied to both references.

## Analog Output Calibration

Output voltage accuracy is assured through the use of the onboard calibration circuitry of the AT-MIO-16X. This circuitry uses a stable, internal, +5 VDC reference that is measured at the factory against a higher accuracy reference; then its value is permanently stored in the EEPROM on the AT-MIO-16X. With this stored reference value, the

AT-MIO-16X board can be recalibrated without external hardware at any time under any number of different operating conditions in order to remove errors caused by temperature drift and time. The AT-MIO-16X is factory calibrated in both unipolar and bipolar modes, and these values are also permanently stored in the EEPROM. Calibration constants can be read from the EEPROM then written to the calibration DACs that adjust offset and gain errors associated with each analog output channel. For each DAC channel, there is an 8-bit offset calibration DAC, and an 8-bit gain calibration DAC. Functions are provided with the board to calibrate the analog output section, access the EEPROM on the board, and write to the calibration DACs. To calibrate an analog output channel, the appropriate DAC signal must be wrapped back to the analog input circuitry. When the AT-MIO-16X leaves the factory, locations 96 through 127 of the EEPROM are protected and cannot be modified. Locations 0 through 95 are unprotected and can be used to store alternate calibration constants for the differing conditions under which the board is used. Refer to Chapter 6, *Calibration Procedures*, for additional calibration information.

## DAC Waveform Circuitry and Timing

There are primarily two modes under which the DACs in the analog output section operate: immediate update and posted update. Immediate update mode is self-evident. You write a value to the DAC and its voltage is *immediately* available at the output. In posted update mode, the voltage is not available at the output until a timer trigger signal initiates an update. This mode has advantages in waveform generation applications which need precisely timed updates that are not software-dependent.

### DAC Waveform Circuitry

Figure 3-10 depicts the three different data paths to the analog output DACs.

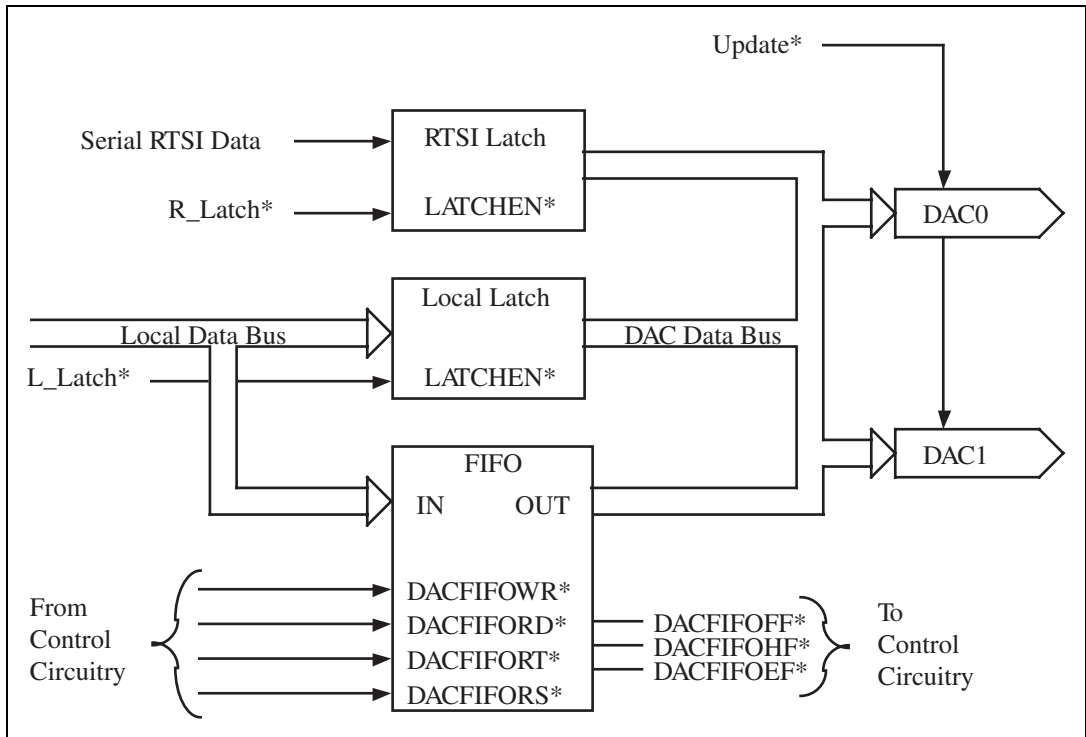

**Figure 3-10.** Analog Output Waveform Circuitry

The local latch is used for immediate updating of the DACs. When data is written to the DACs in immediate updating mode, the data is directly routed to the DACs to be converted to a voltage at the output. In this mode, the Update\* signal is held low, or true. The only path available for data transfer to the DACs in the immediate update mode is the local latch. The path that the data takes to the DACs is determined by the DAC mode enabled through a register in the AT-MIO-16X register set.

The DAC FIFO and RTSI latch are used for posted updating of the DACs. Data written to the DACs is buffered by the DAC FIFO to be updated at a later time. The DAC FIFO can buffer up to 2,048 values before updating the DAC. The RTSI latch is a special case of the posted update mode because data is not directly written to the AT-MIO-16X board from the PC, but it is received serially from the AT-DSP2200. In this case, only one value can be buffered before updating the DAC.

In the posted update mode, you can use any one of the three paths to transfer data to the DACs. Data can be sent through the FIFO and local

latch concurrently or separately. In this instance, the value written to the DAC through the local latch is not updated until the update pulse trigger occurs. If the RTSI latch is used to transfer serial data from the AT-DSP2200 over the RTSI bus, no other transferring path is allowed. In other words, data cannot be transmitted serially over the RTSI bus to DAC Channel 0 and transferred through the FIFO to DAC Channel 1 at the same time. These modes are mutually exclusive.

### DAC Waveform Timing Circuitry

Waveform timing implies precise updating of the analog output DACs to create a pure waveform without any jitter or uncertainty. This timing is accomplished by posting updates to the DACs. Posted update mode configures the DACs to buffer values written to them and update the output voltage only after a trigger signal. This trigger signal can come in the form of an internal counter pulse from Counters 1, 2, 3, or 5 of the Am9513A Counter/Timer, it can be supplied from the EXTMRTRIG\* signal at the I/O connector, or it can be obtained by accessing a register in the AT-MIO-16X register set.

In the posted update mode, requests for writes to the DAC are generated from the TMRREQ signal and can be acknowledged in one of three ways: either polled I/O through monitoring the TMRREQ signal in Status Register 1, interrupts, or DMA. All three response mechanisms will have a delay associated with them in how fast they can respond to the requesting signal. DMA will have the fastest response, followed by polled I/O, and finally interrupts. The advantage of using interrupts is that the CPU is not solely dedicated to monitoring Status Register 1 and can simultaneously perform other tasks. If writes generated from these requests updated the DAC immediately, there could be significant jitter in the resulting output waveform, so values are written to a buffer where they are updated later with a precisely timed update signal. Figure 3-11 depicts the timing for the posted DAC update mode.

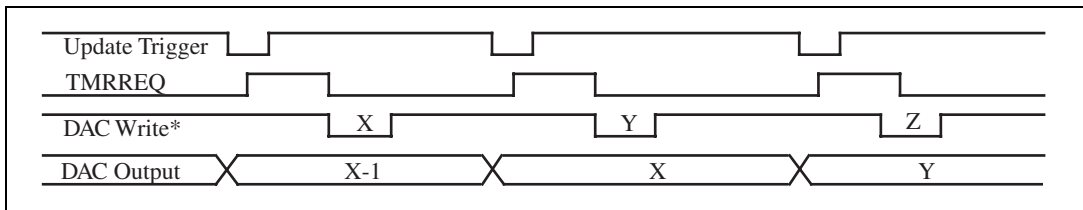
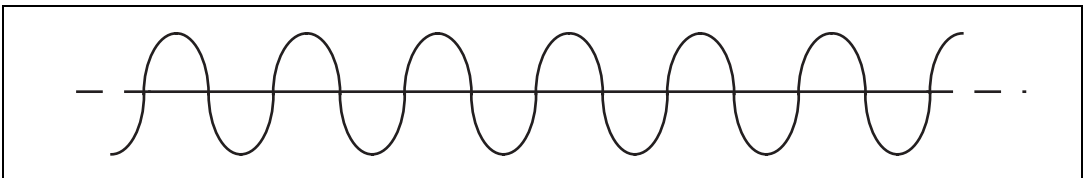

Figure 3-11. Posted DAC Update Timing

In Figure 3-11, the update trigger signal serves to update the previously written value to the DAC. In the posted update mode, the DAC FIFO is used to buffer the data. Requests are generated either when the FIFO is not full or when the FIFO is less than half full. One of these two signals generates the TMRREQ signal. In the example above, requesting is generated when the FIFO is not full. Because each update removes a value from the DAC FIFO, each update also results in the TMRREQ signal being asserted. This sequence of events continues until the output buffer data is exhausted.

There are effectively two different modes in which to operate the DAC FIFOs in posted update mode. Data flows in and out at equal rates, or data as initialized in the FIFO and once updating begins, the data is cycled through when the end of the FIFO buffer is encountered. If waveform cycles involving more than 2,048 values are required, data must continuously flow into and out of the FIFO buffer to be replenished. If waveform cycles of less than 2,048 points are required, the data can be transferred to the DAC FIFO only once where it can be cycled through to generate a continuous waveform. This mode removes the burden on the PC to continuously transfer new data to the DAC FIFO buffer, allowing it to perform other operations. In both cases, waveforms like the one shown in Figure 3-12 can be realized.



**Figure 3-12.** Analog Output Waveform Circuitry

Whether the waveform size is greater than or less than 2,048 points, a waveform can be generated that is seamless, that is, there will be no gaps or missed points in the output waveform. If a point is missed for any reason, the waveform circuitry will automatically stop updating the DAC, and a waveform error signal will be generated that can be monitored in Status Register 1. An error condition, or underflow, occurs when data is extracted from the DAC FIFO faster than it enters, such that at one point the DAC FIFO becomes empty.

Underflow errors occur because of software or hardware latencies in acknowledging the signal requesting more data for the DAC FIFOs. This condition can be prevented in the cyclic mode where the buffer resides wholly in the DAC FIFO and is cycled through to generate a



continuous waveform. The advantage of having the data in the DAC FIFO is that the FIFO never needs to have the data refreshed, therefore it is never empty. Rather than requesting new data, the FIFO simply reuses existing data, removing a large demand on the PC bus bandwidth. Maximum updating performance is achieved in this mode because it does not rely on the speed of the computer. All described waveform modes involving cycling within the DAC FIFO can also be accomplished without the entire buffer fitting inside the FIFO. However, this requires more software intervention and therefore results in a slower rate and decreased reliability.

### FIFO Continuous Cyclic Waveform Generation

In addition to allowing better performance, the cyclic mode provides greater flexibility. Because the hardware is in full control of the buffer, it can start, stop, and restart the generation of the waveform as programmed. An example of this added functionality is shown in Figure 3-13.

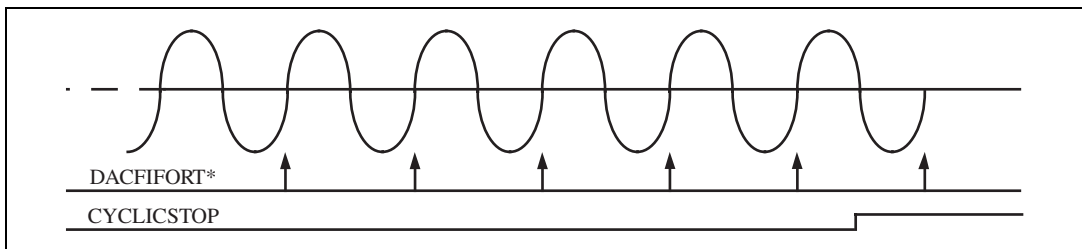
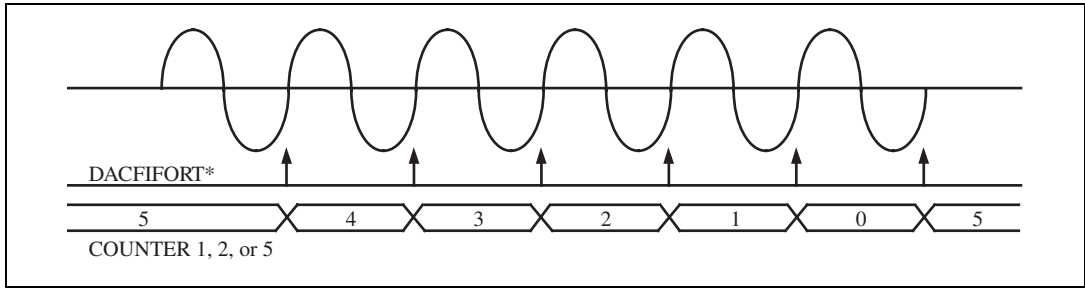

**Figure 3-13.** FIFO Cyclic Waveform Generation with Disable

In this example, the entire buffer fits within the DAC FIFO. After the waveform is initiated, it cycles and recycles through the buffer. The end of the buffer is indicated by the DACFIFORT\* signal, or DAC FIFO Retransmit. This is a signal generated by the hardware in cyclic mode to trigger the DAC FIFO to retransmit its buffer. The CYCLICSTOP signal is programmable through a register in the AT-MIO-16X register set. If this bit is cleared, the DAC FIFO hardware runs ad infinitum or until the timer update pulse triggering is disabled. If necessary, the waveform can be stopped by disabling the timer trigger. The result of this action is to leave the DAC at some unknown value, for example the last updated value. The advantage of the CYCLICSTOP control signal is that DAC updating ends gracefully. When this signal is set, the waveform ends after it encounters the next retransmit signal. Thus, it will always end in a known state at the end of the buffer.

## FIFO Programmed Cyclic Waveform Generation

One step beyond the continuous waveform generation is the programmed cyclic waveform generation. This mode is also available only when the entire buffer fits within the DAC FIFO. Figure 3-14 shows the operation of this mode.

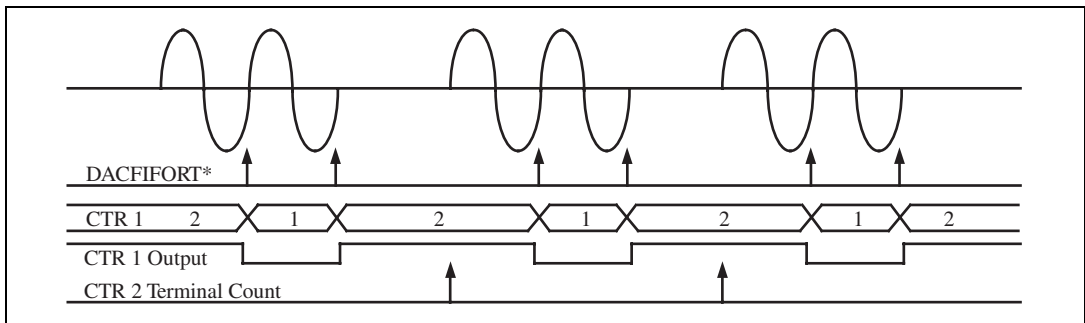

**Figure 3-14.** FIFO Programmed Cyclic Waveform Timing

In this case, one of the counters in the Am9513A Counter/Timer is programmed to count the number of DAC FIFO Retransmit signals. When the counter counts the appropriate number of occurrences, it terminates the waveform sequence. A bit is available in Status Register 1 to indicate termination of a waveform sequence.

## FIFO Pulsed Waveform Generation

Another step beyond cycle counting is pulsed waveform generation. Again, this mode is applicable only if the entire buffer fits within the DAC FIFO. Figure 3-15 shows the operation of this mode and the resulting waveform.



**Figure 3-15.** FIFO Pulsed Waveform Generation Timing

In the pulsed waveform application, Counter 1 of the Am9513A is programmed to count the number of retransmit signals, before terminating the sequence. At this point, Counter 2 serves as an interval timer and then restarting the sequence. This process proceeds ad infinitum until the timer trigger is removed or disabled, or the CYCLICSTOP bit is set.

## Digital I/O Circuitry

The AT-MIO-16X has eight digital I/O lines. These eight digital I/O lines are divided into two ports of four lines each and are located at pins ADIO<3..0> and BDIO<3..0> on the I/O connector. Figure 3-16 shows a block diagram of the digital I/O circuitry.

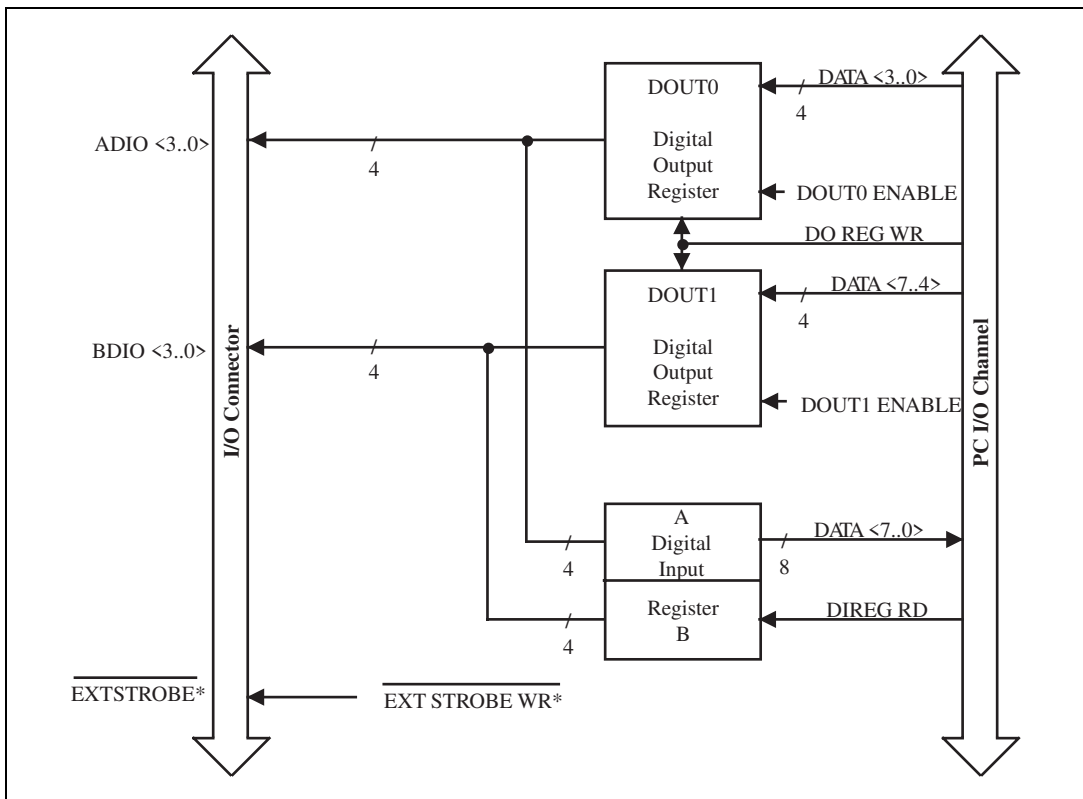

Figure 3-16. Digital I/O Circuitry Block Diagram

The digital I/O lines are controlled by the Digital Output Register and monitored by the Digital Input Register. The Digital Output Register is an 8-bit register that contains the digital output values for both ports 0 and 1. When port 0 is enabled, bits <3..0> in the Digital Output Register are driven onto digital output lines ADIO<3..0>. When port 1 is enabled, bits <7..4> in the Digital Output Register are driven onto digital output lines BDIO<3..0>.

Reading the Digital Input Register returns the state of the digital I/O lines. Digital I/O lines ADIO<3..0> are connected to bits <3..0> of the Digital Input Register. Digital I/O lines BDIO<3..0> are connected to bits <7..4> of the Digital Input Register. When a port is enabled, the Digital Input Register serves as a read-back register, returning the digital output value of the port. When a port is not enabled, reading the Digital Input Register returns the state of the digital I/O lines driven by an external device.

Both the digital input and output registers are TTL-compatible. The digital output ports, when enabled, are capable of sinking 24 mA of current and sourcing 2.6 mA of current on each digital I/O line. When the ports are not enabled, the digital I/O lines act as high-impedance inputs.

The external strobe signal EXTSTROBE\*, shown in Figure 3-16, is a general-purpose strobe signal. Writing to an address location on the AT-MIO-16X board generates an active low 500-nsec pulse on this output pin. EXTSTROBE\* is not necessarily part of the digital I/O circuitry but is shown here because it can be used to latch digital output from the AT-MIO-16X into an external device.

## Timing I/O Circuitry

---

The AT-MIO-16X uses an Am9513A Counter/Timer for data acquisition timing and for general-purpose timing I/O functions. An onboard oscillator is used to generate the 10-MHz clock. Figure 3-17 shows a block diagram of the timing I/O circuitry.

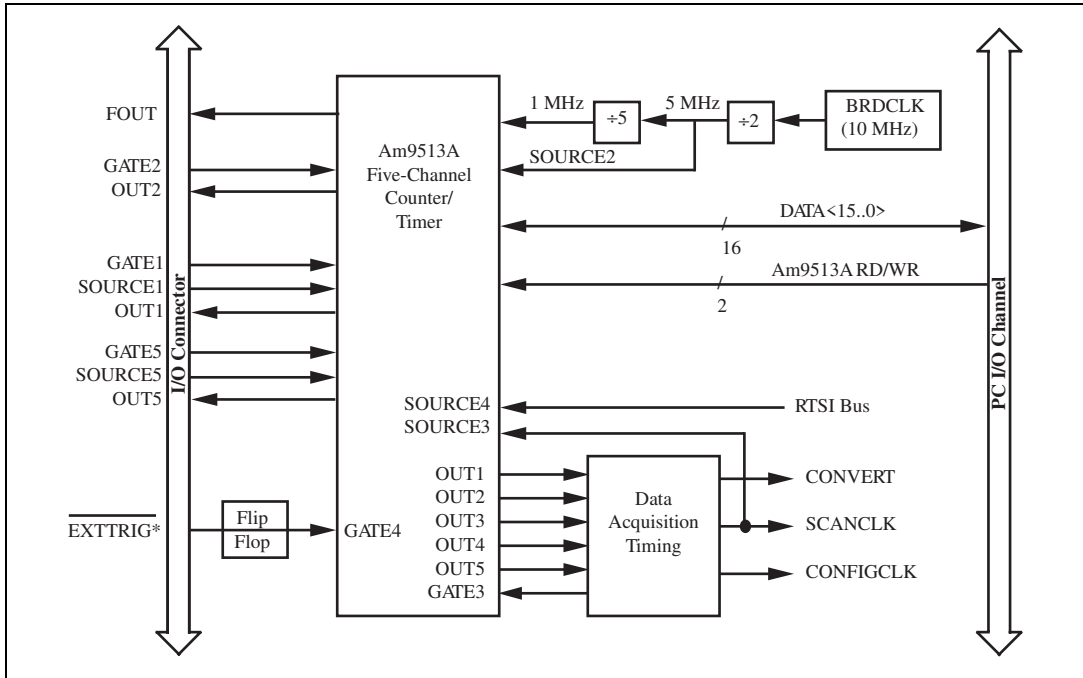

**Figure 3-17.** Timing I/O Circuitry Block Diagram

The Am9513A contains five independent 16-bit counter/timers, a 4-bit frequency output channel, and five internally generated timebases. The five counter/timers can be programmed to operate in several useful timing modes. The programming and operation of the Am9513A are presented in detail in Appendix C, *AMD Am9513A Data Sheet*.

The Am9513A clock input is one-tenth the BRDCLK frequency. BRDCLK is selected through a register in the AT-MIO-16X register set. The factory default for BRDCLK is 10 MHz, which generates a 1-MHz clock input to the Am9513A. The Am9513A uses this clock input plus a BRDCLK divided-by-two input at Source 2 to generate six internal timebases. These timebases can be used as clocks by the counter/timers and by the frequency output channel. When BRDCLK is 10 MHz, the six internal timebases normally used for AT-MIO-16X timing functions are 5 MHz, 1 MHz, 100 kHz, 10 kHz, 1 kHz, and 100 Hz. The 16-bit counters in the Am9513A can be diagrammed as shown in Figure 3-18.

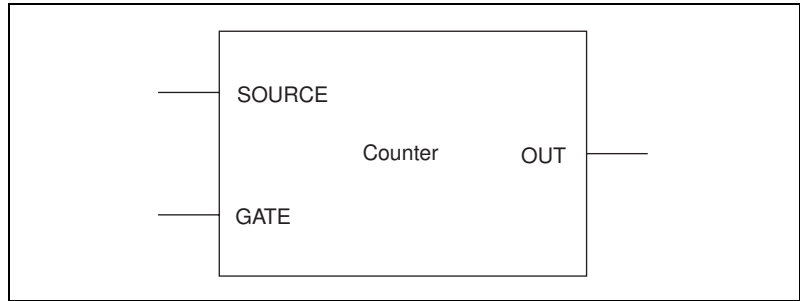

**Figure 3-18.** Counter Block Diagram

Each counter has a SOURCE input pin, a GATE input pin, and an output pin labeled OUT. The Am9513A counters are numbered 1 through 5, and their GATE, SOURCE, and OUT pins are labeled GATE  $N$ , SOURCE  $N$ , and OUT  $N$ , where  $N$  is the counter number.

For counting operations, the counters can be programmed to use any of the five internal timebases, any of the five GATE and five SOURCE inputs to the Am9513A, and the output of the previous counter (Counter 4 uses Counter 3 output, and so on). A counter can be configured to count either falling or rising edges of the selected input.

The counter GATE input allows counter operation to be gated. Once a counter is configured for an operation through software, a signal at the GATE input can be used to start and stop counter operation. The five gating modes available with the Am9513A are as follows:

- No gating
- Level gating active high
- Level gating active low
- Low-to-high edge gating
- High-to-low edge gating

A counter can also be active high level gated by a signal at GATE  $N+1$  and GATE  $N-1$ , where  $N$  is the counter number.

The counter generates timing signals at its OUT output pin. The OUT output pin can also be set to a high-impedance state or a grounded-output state. The counters generate two types of output signals during counter operation: terminal count pulse output and terminal count toggle output. Terminal count is often referred to as TC. A counter reaches TC when it counts up or down and rolls over. In many

counter applications, the counter reloads from an internal register when it reaches TC. In TC pulse output mode, the counter generates a pulse during the cycle that it reaches TC and reloads. In TC toggle output mode, the counter output changes state after it reaches TC and reloads. In addition, the counters can be configured for positive logic output or negative (inverted) logic output for a total of four possible output signals generated for one timing mode.

The GATE and OUT pins for Counters 1, 2, and 5 and SOURCE pins for Counters 1 and 5 of the onboard Am9513A are located on the AT-MIO-16X I/O connector. A falling edge signal on the EXTTRIG\* pin of the I/O connector or writing to the STARTDAQ register during a data acquisition sequence sets the flip-flop output signal connected to the GATE4 input of the Am9513A and can be used as an additional gate input. This mode is also used in the pretrigger data acquisition mode. The flip-flop output connected to GATE4 is cleared when the sample counter reaches TC, when an overflow or overrun occurs, or when the DAQ Clear Register is written to. An overrun is defined as an error generated when the ADC cannot keep up with its programmed conversion speed.

The Am9513A SOURCE5 pin is connected to the AT-MIO-16X RTSI switch, which means that a signal from the RTSI trigger bus can be used as a counting source for the Am9513A counters.

The Am9513A OUT1, OUT2, OUT3 (EXTCONV\*), and OUT5 pins can be used in several different ways. If waveform generation is enabled, an active low pulse on the output of the counter selected through the RTSI switch updates the analog output on the two DACs. The counter outputs can also be used to trigger interrupt and DMA requests. If the proper mode is selected in Command Register 2, an interrupt or DMA request occurs when a falling edge signal is detected on the selected DAC update signal.

Counters 3 and 4 of the Am9513A are dedicated to data acquisition timing, and therefore are not available for general-purpose timing applications. Signals generated at OUT3 and OUT4 are sent to the data acquisition timing circuitry. GATE3 is controlled by the data acquisition timing circuitry. OUT3 is internally connected to EXTCNV\* so that when internal data acquisition sequences (OUT3) are used, EXTCNV\* should be disconnected or tristated. For the same reason, if external data acquisition sequences (EXTCONV\*) are used, OUT3 should be programmed to the high-impedance state.

Counter 5 is sometimes used by the data acquisition timing circuitry and concatenated with Counter 4 to form a 32-bit sample counter. The SCANCLK signal is connected to the SOURCE3 input of the Am9513A, and OUT1 is sent to the data acquisition timing circuitry. This allows Counter 1 to be used to divide the SCANCLK signal for generating the CONFIGCLK signal. See the *Data Acquisition Timing Circuitry* section earlier in this chapter.

Counter 2 is sometimes used by the data acquisition timing circuitry to assign a time interval to each cycle through the scan sequence programmed in the channel configuration register. This mode is called interval channel scanning. See the *Multiple-Channel Data Acquisition* section earlier in this chapter.

The Am9513A 4-bit programmable frequency output channel is located at the I/O connector FOUT pin. Any of the five internal timebases and any of the counter SOURCE or GATE inputs can be selected as the frequency output source. The frequency output channel divides the selected source by its 4-bit programmed value and makes the divided down signal available at the FOUT pin.

## RTSI Bus Interface Circuitry

The AT-MIO-16X is interfaced to the National Instruments RTSI bus. The RTSI bus has seven trigger lines and a system clock line. All National Instruments AT Series boards with RTSI bus connectors can be wired together inside the PC and share these signals. A block diagram of the RTSI bus interface circuitry is shown in Figure 3-19.

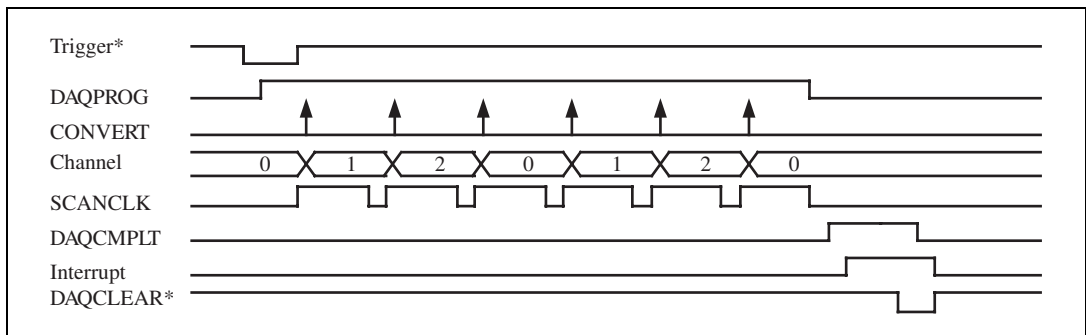

**Figure 3-19.** RTSI Bus Interface Circuitry Block Diagram



The RTSICLK line can be used to source a 10-MHz signal across the RTSI bus or to receive another clock signal from another AT board connected to the RTSI bus. BRDCLK is the system clock used by the AT-MIO-16X. Bits in a command register in the AT-MIO-16X register set control how these clock signals are routed.

The RTSI switch is a National Instruments custom integrated circuit that acts as a 7×7 crossbar switch. Pins B<6..0> are connected to the seven RTSI bus trigger lines. Pins A<6..0> are connected to seven signals on the board. The RTSI switch can drive any of the signals at pins A<6..0> onto any one or more of the seven RTSI bus trigger lines and can drive any of the seven trigger line signals onto any one or more of the pins A<6..0>. This capability provides a completely flexible signal interconnection scheme for any AT Series board sharing the RTSI bus. The RTSI switch is programmed via its chip select and data inputs.

On the AT-MIO-16X board, nine signals are connected to pins A<6..0> of the RTSI switch with the aid of additional drivers. The signals GATE1, OUT1, OUT2, SOURCE5, OUT5, and FOUT are shared with the AT-MIO-16X I/O connector and Am9513A Counter/Timer. The EXTCONV\* and EXTTRIG\* signals are shared with the I/O connector and the data acquisition timing circuitry. The TMRTRIG\* signal is used to update the two DACs on the AT-MIO-16X. These onboard interconnections allow AT-MIO-16X general-purpose and data acquisition timing to be controlled over the RTSI bus as well as externally, and allow the AT-MIO-16X and the I/O connector to send timing signals to other AT boards connected to the RTSI bus.

# Register Map and Descriptions

Chapter

4

This chapter describes in detail the address and function of each of the AT-MIO-16X control and status registers.



**Note:** *If you plan to use a programming software package such as NI-DAQ or LabWindows/CVI with your AT-MIO-16X board, you need not read this chapter. However, you will gain added insight into your AT-MIO-16X board by reading this chapter.*

## Register Map

The register map for the AT-MIO-16X is shown in Table 4-1. This table gives the register name, the register offset address, the type of the register (read-only, write-only, or read-and-write) and the size of the register in bits. The actual register address is obtained by adding the appropriate register offset to the I/O base address of the AT-MIO-16X.

Registers are grouped in the table by function. Each register group is introduced in the order shown in Table 4-1, then described in detail, including a bit-by-bit description.

**Table 4-1.** AT-MIO-16X Register Map

Register Name	Offset Address (Hex)	Type	Size
Configuration and Status Register Group			
Command Register 1	0	Write-only	16-bit
Command Register 2	2	Write-only	16-bit
Command Register 3	4	Write-only	16-bit
Command Register 4	6	Write-only	16-bit
Status Register 1	18	Read-only	16-bit
Status Register 2	1A	Read-only	16-bit
Analog Input Register Group			
ADC FIFO Register	0	Read-only	16-bit
CONFIGMEM Register	8	Write-only	16-bit

**Table 4-1.** AT-MIO-16X Register Map (Continued)

<b>Register Name</b>	<b>Offset Address (Hex)</b>	<b>Type</b>	<b>Size</b>
Analog Output Register Group			
DAC0 Register	10	Write-only	16-bit
DAC1 Register	12	Write-only	16-bit
ADC Event Strobe Register Group			
CONFIGMEMCLR Register	1B	Read-only	8-bit
CONFIGMEMLD Register	1B	Write-only	8-bit
DAQ Clear Register	19	Read-only	8-bit
DAQ Start Register	1D	Read-only	8-bit
Single Conversion Register	1D	Write-only	8-bit
ADC Calibration Register	1F	Write-only	8-bit
DAC Event Strobe Register Group			
TMRREQ Clear Register	1F	Read-only	8-bit
DAC Update Register	18	Write-only	16-bit
DAC Clear Register	1E	Read-only	8-bit
General Event Strobe Register Group			
DMA Channel Clear Register	0B	Read-only	8-bit
DMATCA Clear Register	19	Write-only	8-bit
DMATCB Clear Register	09	Read-only	8-bit
External Strobe Register	1E	Write-only	8-bit
Calibration DAC 0 Load Register	0A	Write-only	8-bit
Calibration DAC 1 Load Register	1A	Write-only	8-bit
Am9513A Counter/Timer Register Group			
Am9513A Data Register	14	Read-and-write	16-bit
Am9513A Command Register	16	Write-only	16-bit
Am9513A Status Register	16	Read-only	16-bit
Digital I/O Register Group			
Digital Input Register	1C	Read-only	16-bit
Digital Output Register	1C	Write-only	16-bit
RTSI Switch Register Group			
RTSI Switch Shift Register	0C	Write-only	8-bit
RTSI Switch Strobe Register	0E	Write-only	8-bit

## Register Sizes

Two different transfer sizes for read-and-write operations are available on the PC: byte (8-bit) and word (16-bit). Table 4-1 shows the size of each AT-MIO-16X register. For example, reading the ADC FIFO Register requires a 16-bit (word) read operation at the selected address, whereas writing to the RTSI Strobe Register requires an 8-bit (byte) write operation at the selected address. These register size accesses must be adhered to for proper board operation. Performing a byte access on a word location is an invalid operation and should be avoided. The converse is also true. Performing a word access on a byte location is also an invalid operation and should be avoided. You should pay particular attention to the register sizes—they are very important.

## Register Description Format

The remainder of this register description chapter discusses each of the AT-MIO-16X registers in the order shown in Table 4-1. Each register group is introduced, followed by a detailed bit description of each register. The individual register description gives the address, type, word size, and bit map of the register, followed by a description of each bit.

The register bit map shows a diagram of the register with the MSB shown on the left (bit 15 for a 16-bit register, bit 7 for an 8-bit register), and the LSB shown on the right (bit 0). A square is used to represent each bit. Each bit is labeled with a name inside its square. An asterisk (\*) after the bit name indicates that the bit is inverted (negative logic).

In many of the registers, several bits are labeled with an X, indicating *don't care* bits. When a register is read, these bits may appear set or cleared but should be ignored because they have no significance.

The bit map field for some registers states *not applicable, no bits used*. Accessing these registers generates a strobe in the AT-MIO-16X. These strobes are used to initiate some onboard event to occur. For example, they can be used to clear the analog input circuitry or to start a data acquisition operation. The data is ignored when writing to these registers; therefore, any bit pattern suffices. Likewise, data returned from a strobe register read access is meaningless.

## Configuration and Status Register Group

The six registers making up the Configuration and Status Register Group allow general control and monitoring of the AT-MIO-16X hardware. Command Registers 1, 2, 3, and 4 contain bits that control operation of several different pieces of the AT-MIO-16X hardware. Status Registers 1 and 2 can be used to read the state of different pieces of the AT-MIO-16X hardware.

Bit descriptions of the six registers making up the Configuration and Status Group are given on the following pages.

## Command Register 1

Command Register 1 contains 11 bits that control AT-MIO-16X serial device access, and data acquisition mode selection. The contents of this register are not defined upon power up and are not cleared after a reset condition. This register should be initialized through software.

**Address:** Base address + 00 (hex)

**Type:** Write-only

**Word Size:** 16-bit

**Bit Map:**

15	14	13	12	11	10	9	8
EEPROMCS	SDATA	SCLK	SCANDIV	0	INTGATE	RETRIG_DIS	DAQEN
MSB							
7	6	5	4	3	2	1	0
SCANEN	SCN2	CNT32/16*	RTSITRIG	0	0	0	0
LSB							

Bit	Name	Description
15	EEPROMCS	EEPROM Chip Select—This bit controls the chip select of the onboard EEPROM used to store calibration constants. When EEPROMCS is set, the chip select signal to the EEPROM is enabled. Before EEPROMCS is brought high, SCLK should first be pulsed high to initialize the EEPROM circuitry.
14	SDATA	Serial Data—This bit is used to transmit a single bit of data to the EEPROM and both of the calibration DACs.
13	SCLK	Serial Clock—A low-to-high transition of this bit clocks data from SDATA into the EEPROM (when EEPROMCS is set) and the calibration DAC. If EEPROMCS is cleared, toggling SCLK does not affect the EEPROM. Serial data is always loaded into the calibration DACs, but the information is not updated until after the

		application of the appropriate load signal.
12	SCANDIV	Scan Divide—This bit controls the configuration memory sequencing during scanned data acquisition. If SCANDIV is set, then sequencing is controlled by Counter 1 of the Am9513A Counter/Timer. If SCANDIV is cleared, the configuration memory is sequenced after each conversion during scanning.
11	0	Reserved—This bit must always be set to zero.
10	INTGATE	Internal Gate—This bit controls internal and external A/D conversions. When INTGATE is set, no A/D conversions take place. When INTGATE is cleared, A/D conversions take place normally. INTGATE can be used as a software gating tool, or to inhibit random conversions during setup operations.
9	RETRIG_DIS	Retrigger Disable—This bit controls retriggering of the AT-MIO-16X data acquisition circuitry. When RETRIG_DIS is set, retriggering of the data acquisition circuitry is inhibited until the end of the previous operation is acknowledged by clearing the DAQPROG bit in Status Register 0. When RETRIG_DIS is cleared, the data acquisition circuitry may be retriggered any time following the end of the previous acquisition sequence.
8	DAQEN	Data Acquisition Enable—This bit enables and disables a data acquisition operation that is controlled by the onboard sample-interval and sample counters. If DAQEN is set, a software DAQ Start or hardware (EXTTRIG*) trigger starts the programmed counters,

thereby initiating a data acquisition operation. If DAQEN is cleared, software and hardware triggers have no effect.

7	SCANEN	Scan Enable—This bit controls multiple-channel scanning during data acquisition. If SCANEN is set and DAQEN is also set, alternate analog input channels are sampled during data acquisition under control of the channel configuration memory. If SCANEN is cleared and DAQEN is set, a single analog input channel is sampled during the entire data acquisition operation. When SCANEN is set, the SCANCLK signal at the I/O connector is enabled. Otherwise, it is disabled.
6	SCN2	Scan Mode 2—This bit selects the data acquisition scanning mode used when scanning multiple A/D channels. If SCN2 is set and SCANEN and DAQEN are set, interval-channel scanning is used. In this mode, scan sequences occur during a programmed time interval, called a <i>scan interval</i> . One cycle of the scan sequence occurs during each scan interval. If SCN2 is cleared and SCANEN and DAQEN are set, continuous channel scanning is used. In this mode, scan sequences are repeated with no delays between cycles.
5	CNT32/16*	32 or 16* Bit Sample Count—This bit selects the count resolution for the number of A/D conversions to be performed in a data acquisition operation. If CNT32/16* is cleared, a 16-bit count mode is selected and Counter 4 of the Am9513A Counter/Timer controls conversion counting. If CNT32/16* is set, a 32-bit count mode is selected and Counter 4 is



			concatenated with Counter 5 to control conversion counting. A 16-bit count mode can be used if the number of A/D sample conversions to be performed is less than 65,537. A 32-bit count mode should be used if the number of A/D sample conversions to be performed is greater than or equal to 65,537.
4	RTSITRIG		RTSI Trigger—This bit controls multiple board synchronization through RTSI Bus triggering. If RTSITRIG is set, then triggering of the data acquisition sequence by another National Instruments board over the RTSI bus is enabled. Otherwise, if RTSITRIG is cleared, the data acquisition sequence is triggered by the onboard Start DAQ Register or a high-to-low transition on the EXTTRIG* signal at the I/O Connector. When this bit is set, the local DAQ Start Register and the EXTTRIG* signal have no effect.
3-0	0		Reserved—These bits must always be set to zero.

## Command Register 2

Command Register 2 contains 15 bits that control AT-MIO-16X RTSI bus transceivers, analog output configuration, and DMA Channels A and B selection. Bits 8-15 of this register are cleared upon power up and after a reset condition. Bits 0-7 of this register are undefined upon power up and are not cleared after a reset condition. These bits should be initialized through software.

**Address:** Base address + 02 (hex)

**Type:** Write-only

**Word Size:** 16-bit

**Bit Map:**

15	14	13	12	11	10	9	8
A4RCV	A4DRV	A2RCV	A2DRV	BIPDAC1	BIPDAC0	EXTREFDAC1	EXTREFDAC0
MSB							
7	6	5	4	3	2	1	0
EISA_DMA	0	DMACHBB2	DMACHBB1	DMACHBB0	DMACHAB2	DMACHAB1	DMACHAB0
LSB							

Bit	Name	Description
15	A4RCV	RTSI A4 Receive—This bit controls the signal source for the TMRTRIG* (Timer Trigger) signal. The TMRTRIG* signal updates the DACs in delayed update mode. If A4RCV is set, pin A4 of the RTSI switch drives the TMRTRIG* signal. If A4RCV is cleared, the TMRTRIG* signal is driven by the EXTTMRTRG* signal from the I/O connector.
14	A4DRV	RTSI A4 Drive—This bit controls the driver that allows the OUT5 signal to drive pin A4 of the RTSI switch. If A4DRV is set, pin A4 of the RTSI switch is driven by OUT5. If A4DRV is cleared, pin A4 is not driven by OUT5, and it can be driven by a signal on the RTSI bus.

13	A2RCV	RTSI A2 Receive—This bit controls the driver that allows the GATE1 signal to be driven from pin A2 of the RTSI switch. If A2RCV is set, pin A2 of the RTSI switch drives the GATE1 signal. In this case, GATE1 may not be driven by a signal at the I/O connector.
12	A2DRV	RTSI A2 Drive—This bit controls the driver that allows the OUT2 signal to drive pin A2 of the RTSI switch. If A2DRV is set, pin A2 of the RTSI switch is driven by OUT2. If A2DRV is cleared, pin A2 is not driven by OUT2, and it can be driven by a signal on the RTSI bus.
11	BIPDAC1	Bipolar DAC 1—This bit configures the range of DAC 1 in the analog output section. If this bit is set, DAC 1 is configured for bipolar operation of $-V_{ref}$ to $+V_{ref}$ . In this mode, data written to this DAC is interpreted in two's complement format. If this bit is cleared, DAC 1 is configured for unipolar operation of 0 V to $+V_{ref}$ . In this mode, data written to DAC 1 is interpreted in straight binary format.
10	BIPDAC0	Bipolar DAC 0—This bit configures the range of DAC 0 in the analog output section. If this bit is set, then DAC 0 is configured for bipolar operation of $-V_{ref}$ to $+V_{ref}$ . In this mode, data written to this DAC is interpreted in two's complement format. If this bit is cleared, then DAC 0 is configured for unipolar operation of 0 V to $+V_{ref}$ . In this mode, data written to DAC 0 is interpreted in straight binary format.

9	EXTREFDAC1	External Reference for DAC 1—This bit controls the reference selection for DAC 1 in the analog output section. If this bit is set, the reference used for DAC 1 is the external reference voltage from the I/O connector. If this bit is cleared, the internal +10 V <sub>ref</sub> is used for the DAC 1 reference.
8	EXTREFDAC0	External Reference for DAC 0—This bit controls the reference selection for DAC 0 in the analog output section. If this bit is set, the reference used for DAC 0 is the external reference voltage from the I/O connector. If this bit is cleared, the internal +10 V <sub>ref</sub> is used for the DAC 0 reference.
7	EISA_DMA	EISA Computer DMA—This bit controls the type of DMA transfer from the ADC FIFO on an EISA computer. If EISA_DMA is clear, single transfer DMA mode is used. If EISA_DMA is set, demand-mode DMA is used. This bit should only be set if the AT-MIO-16X is installed in an EISA-type computer.
6	0	Reserved—This bit must always be set to zero.
5-3	DMACHBB<2..0>	DMA Channel B Select—These bits select the secondary DMA channel for use by the AT-MIO-16X. See Table 4-2.
2-0	DMACHAB<2..0>	DMA Channel A Select—These bits select the primary DMA channel for use by the AT-MIO-16X. See Table 4-2.

**Table 4-2.** DMA Channel Selection

Bit Pattern			Effect	Bit Pattern			Effect
DMA CHAB2	DMA CHAB1	DMA CHAB0	Primary DMA Channel Selected (A)	DMA CHBB2	DMA CHBB1	DMA CHBB0	Secondary DMA Channel Selected (B)
0	0	0	DMA Channel 0	0	0	0	DMA Channel 0
0	0	1	DMA Channel 1	0	0	1	DMA Channel 1
0	1	0	DMA Channel 2	0	1	0	DMA Channel 2
0	1	1	DMA Channel 3	0	1	1	DMA Channel 3
1	0	0	No effect	1	0	0	No effect
1	0	1	DMA Channel 5	1	0	1	DMA Channel 5
1	1	0	DMA Channel 6	1	1	0	DMA Channel 6
1	1	1	DMA Channel 7	1	1	1	DMA Channel 7

## Command Register 3

Command Register 3 contains 16 bits that control the ADC link to the AT-DSP2200, digital I/O port, interrupt and DMA modes, and interrupt channel selection. The contents of this register are defined to be cleared upon power up and after a reset condition.

**Address:** Base address + 04 (hex)

**Type:** Write-only

**Word Size:** 16-bit

**Bit Map:**

15	14	13	12	11	10	9	8
ADCDSP	DIOPBEN	DIOPAEN	DMATCINT	DACCMPLINT	DAQCMPLINT	I/O_INT	DMACHA
MSB							
7	6	5	4	3	2	1	0
DMACHB	ADCREQ	DAC1REQ	DAC0REQ	DRVAIS	INTCHB2	INTCHB1	INTCHB0
LSB							

Bit	Name	Description
15	ADCDSP	ADC DSP Link Enable—This bit controls the serial link from the A/D converter to the AT-DSP2200. If ADCDSP is set, then the serial link is enabled. Data from channels that have been marked in the channel configuration memory will be transmitted over the RTSI bus. If ADCDSP is cleared, the serial RTSI link is disabled, irrespective of the marking of channels in the channel configuration memory.
14	DIOPBEN	Digital I/O Port B Enable—This bit controls the 4-bit digital output port B. If DIOPBEN is set, the Digital Output Register drives the DIO<8..5> digital lines at the I/O connector. If DIOPBEN is cleared, the Digital Output Register drivers are set to a high-impedance state; therefore, an external device can drive the DIO<8..5> digital lines.

13	DIOPAEN	Digital I/O Port A Enable—This bit controls the 4-bit digital port A. If DIOPAEN is set, the Digital Output Register drives the DIO<4..1> digital lines at the I/O connector. If DIOPAEN is cleared, the Digital Output Register drivers are set to a high-impedance state; therefore, an external device can drive the DIO<4..1> digital lines.
12	DMATCINT	DMA Terminal Count Interrupt Enable—This bit controls the generation of an interrupt when a DMA terminal count pulse is received from the DMA controller in the PC AT. If DMATCINT is set, an interrupt request is generated when the DMA controller transfers the final value on the primary DMA channel, Channel A, or the secondary DMA channel, Channel B. The interrupt request is serviced by strobing the appropriate DMATC Clear Register. When DMATCINT is cleared, no DMA terminal count interrupts are generated.
11	DACCMLINT	DAC Complete Interrupt Enable—This bit controls the generation of an interrupt when a DAC sequence completes. If DACCMLINT is set, an interrupt request is generated when the sequence completes. The interrupt request is serviced by strobing the TMRREQ Clear or DAC Clear Register. When DACCMLINT is cleared, completion of a sequence does not generate an interrupt. A DAC sequence ends by running its course or when an error condition occurs such as UNDERFLOW.
10	DAQMPLINT	DAQ Complete Interrupt Enable—This bit controls the generation of an interrupt when a data acquisition sequence completes. If DAQMPLINT is set, an interrupt request is generated when the

data acquisition operation completes. The interrupt request is serviced by strobing the DAQ Clear Register. When DAQCMPLINT is cleared, completion of a data acquisition sequence does not generate an interrupt. A data acquisition sequence ends by running its course or when an error condition occurs such as OVERRUN or OVERFLOW.

9	I/O_INT	Input/Output Interrupt Enable—This bit, along with the appropriate mode bits, enables and disables I/O interrupts generated from the AT-MIO-16X. To select a specific mode, refer to Table 4-3 for available modes and associated bit patterns.
8	DMACHA	DMA Channel A Enable—This bit controls the generation of DMA requests on DMA Channel A as selected in Command Register 2. DMA requests are generated from A/D conversions as well as from timer updates. If DMACHA is set, then requesting is enabled for DMA Channel A. If DMACHA is cleared, no DMA requests are generated on DMA Channel A. To select a specific mode, refer to Table 4-3 for available modes and associated bit patterns.
7	DMACHB	DMA Channel B Enable—This bit controls the generation of DMA requests on DMA Channel B as selected in Command Register 2. DMA requests are generated from A/D conversions as well as from timer updates. If DMACHB is set, requesting is enabled for DMA Channel B. If DMACHB is cleared, no DMA requests are generated on DMA Channel B. To select a specific mode, refer to Table 4-3 for available modes and associated bit patterns.



6

ADCREQ

ADC Request Enable—This bit controls DMA requesting and interrupt generation from an A/D conversion. If this bit is set, an interrupt or DMA request is generated when an A/D conversion is available in the FIFO. If this bit is cleared, no DMA request or interrupt is generated following an A/D conversion. To select a specific mode, refer to Table 4-3 for available modes and associated bit patterns.

**Table 4-3.** DMA and Interrupt Modes

Interface Mode						Mode Description
IO_INT	DMACHA	DMACHB	ADCREQ	DAC1REQ	DAC0REQ	
0	1	0	0	0	1	Channel A to DAC0
0	1	0	0	1	0	Channel A to DAC1
0	1	0	0	1	1	Channel A to DAC0 and DAC1 (interleaved)
0	1	0	1	0	0	Channel A from ADC
0	0	1	0	0	1	Channel B to DAC0
0	0	1	0	1	0	Channel B to DAC1
0	0	1	0	1	1	Channel B to DAC0 and DAC1 (interleaved)
0	0	1	1	0	0	Channel B from ADC
0	1	1	0	0	0	Channel A and Channel B to DAC0 and DAC1 (double-buffered)
0	1	1	0	0	1	Channel A and Channel B to DAC0 (double-buffered)
0	1	1	0	1	0	Channel A and Channel B to DAC1 (double-buffered)
0	1	1	0	1	1	Channel A and Channel B to DAC0 and DAC1 (sync double-channel)
0	1	1	1	0	0	Channel A and Channel B from ADC (double-buffered)

**Table 4-3.** DMA and Interrupt Modes (Continued)

Interface Mode						Mode Description
IO_INT	DMACHA	DMACHB	ADCREQ	DAC1REQ	DAC0REQ	
0	1	1	1	0	1	Channel A from ADC, Channel B to DAC0
0	1	1	1	1	0	Channel A from ADC, Channel B to DAC1
0	1	1	1	1	1	Channel A from ADC, Channel B to DAC0 and DAC1 (interleaved)
1	0	0	0	0	1	Timer interrupt
1	0	0	0	1	0	Timer interrupt
1	0	0	0	1	1	Timer interrupt
1	0	0	1	0	0	ADC interrupt
1	0	0	1	0	1	ADC and timer interrupt
1	0	0	1	1	0	ADC and timer interrupt
1	0	0	1	1	1	ADC and timer interrupt
1	0	0	0	0	1	Channel A to DAC0 with ADC interrupt
1	1	0	0	1	0	Channel A to DAC1 with ADC interrupt
1	1	0	0	1	1	Channel A to DAC0 and DAC1 (interleaved) with ADC interrupt
1	1	0	1	0	0	Channel A from ADC with timer interrupt
1	0	1	0	1	0	Channel B to DAC1 with ADC interrupt
1	0	1	0	1	1	Channel B to DAC0 and DAC1 (interleaved) with ADC interrupt
1	0	1	1	0	0	Channel B from ADC with timer interrupt
1	1	1	1	0	1	Channels A and B to DACs 0 and 1 (double-buffered) with ADC interrupt

**Table 4-3.** DMA and Interrupt Modes (Continued)

Interface Mode						Mode Description
IO_INT	DMACHA	DMACHB	ADCREQ	DAC1REQ	DAC0REQ	
1	1	1	0	0	1	Channel A and Channel B to DAC0 (double-buffered) with ADC interrupt
1	1	1	0	1	0	Channel A and Channel B to DAC1 (double-buffered) with ADC interrupt
1	1	1	0	1	1	Channels A and B to DACs 0 and 1 (sync double-channel) with ADC interrupt
1	1	1	1	0	0	Channels A and B from ADC (double-buffered) with timer interrupt
1	1	1	1	0	1	Channel A to DAC0 and Channel B from ADC
1	1	1	1	1	0	Channel A to DAC1 and Channel B from ADC
1	1	1	1	1	1	Channel A to DAC0 and DAC1 (interleaved) and Channel B from ADC

5                    DAC1REQ            DAC 1 Request Enable—This bit controls DMA requesting and interrupt generation from D/A updates. If this bit is set, an interrupt or DMA request is generated when the DAC is ready to receive data. If this bit is cleared, no DMA request or interrupt is generated. To select a specific mode, refer to Table 4-3 for available modes and associated bit patterns.

4                    DAC0REQ            DAC 0 Request Enable—This bit controls DMA requesting and interrupt generation from D/A updates. If this bit is set, an interrupt or DMA request is generated when the DAC is ready to receive data. If this bit is cleared, no DMA request or interrupt is generated. To select a specific mode, refer to

Table 4-3 for available modes and associated bit patterns.

- 3            **DRVAIS**            Drive Analog Input Sense—This signal controls the AI SENSE signal at the I/O connector. AI SENSE is always used as an input in the NRSE input configuration mode irrespective of DRVAIS. If DRVAIS is set, then AI SENSE is connected to board ground unless the board is configured in the NRSE mode, in which case AI SENSE is used as an input. If DRVAIS is cleared, AI SENSE is used as an input in the NRSE input configuration, and is not driven otherwise.
- 2-0            **INTCHB<2..0>**            Interrupt Channel Select—These bits select the interrupt channel available for use by the AT-MIO-16X. See Table 4-4.

**Table 4-4.** Interrupt Level Selection

Bit Pattern			Effect
INTCHB2	INTCHB1	INTCHB0	Interrupt Level Enabled
0	0	0	Level 3
0	0	1	Level 4
0	1	0	Level 5
0	1	1	Level 7
1	0	0	Level 10
1	0	1	Level 11
1	1	0	Level 12
1	1	1	Level 15

## Command Register 4

Command Register 4 contains 16 bits that control the AT-MIO-16X board clock selection, serial DAC link over the RTSI bus, DAC mode selection, and miscellaneous configuration bits.

Bits 8-15 of this register are cleared upon power up or following a reset condition. Bits 0-7 of this register are undefined upon power up and are not cleared after a reset condition. These bits should be initialized through software.

**Address:** Base address + 06 (hex)

**Type:** Write-only

**World Size:** 16-bit

**Bit Map:**

15	14	13	12	11	10	9	8
CLKMODEB1	CLMODEB0	DAC1DSP	DAC0DSP	DACMB3	DACMB2	DACMB1	DACMB0
MSB							
7	6	5	4	3	2	1	0
DACGATE	DB_DIS	CYCLICSTOP	ADCFIFOREQ	SRC3SEL	GATE2SEL	FIFO/DAC	EXTTRIG_DIS
LSB							

Bit	Name	Description
15-14	CLKMODEB<1..0>	Clock Mode Select—These bits control the selection of the board clock and RTSI bus clock. Upon power up, CLKMODEB1 and CLKMODEB0 are cleared. In this condition, the board is configured for internal, 10-MHz operation. For other available modes see Table 4-5 for bit patterns.

**Table 4-5.** Board and RTSI Clock Selection

Bit Pattern		Effect	
CLKMODEB1	CLKMODEB0	RTSI Clock	Board Clock
X	0	No connection	Internal, 10 MHz
0	1	Internal, 10 MHz	Internal, 10 MHz
1	1	Driven onto board clock	Received from RTSI clock

- 13            DAC1DSP      DAC 1 DSP Link Enable—This bit controls the serial link from the AT-DSP2200 to DAC 1 of the analog output section. If DAC1DSP is set, then the serial link is enabled. Data is sent from the AT-DSP2200 over the RTSI bus and is accepted by DAC 1. If DAC1DSP is cleared, the serial RTSI link is disabled.
- 12            DAC0DSP      DAC 0 DSP Link Enable—This bit controls the serial link from the AT-DSP2200 to DAC 0 of the analog output section. If DAC0DSP is set, then the serial link is enabled. Data is sent from the AT-DSP2200 over the RTSI bus and is accepted by DAC 0. If DAC0DSP is cleared, the serial RTSI link is disabled.
- 11-8        DACMB<3..0>      DAC Mode Select—These bits control the mode used to and updating the DACs. DACMB3 is used to select the number of reads from the DAC FIFO per update signal, when in waveform generation modes. If DACMB3 is clear, there will be only one read of the DAC FIFO per

update. If DACMB3 is set, the circuitry will determine whether to perform one read or two reads from the DAC FIFO depending on the data in the FIFO. See Table 4-6 for available modes and bit patterns.

**Table 4-6.** Analog Output Waveform Modes

Waveform Mode				Mode Description
DACMB3	DACMB2	DACMB1	DACMB0	
0	0	0	0	Single update with no timed interrupts
1	0	0	0	Single update with timed interrupts
X	0	0	1	DMA access through DAC FIFO (with single requesting)
X	0	1	0	DMA access through DAC FIFO (with half flag requesting)
X	0	1	1	FIFO continuous waveform generation (buffer in DAC FIFO)
X	1	0	0	Programmed cycle waveform generation (Counter 1 stops after N cycles)
X	1	0	1	Programmed cycle waveform generation (Counter 2 stops after N cycles)
X	1	1	0	Programmed cycle waveform generation (Counter 5 stops after N cycles)
X	1	1	1	Pulsed waveform (Counter 1 stops after N cycles, Counter 2 restarts)

7                    DACGATE            DAC Update Gate—This bit controls the update circuitry for the DACs in the delayed update mode. If DACGATE is set, updating of the DACs is inhibited.

		Values can be directly written to the DAC, but not through the DAC FIFO. If DACGATE is cleared, updating of and writing to the DACs proceeds normally.
6	DB_DIS	Double Buffering Disable—This bit controls the updating of the DACs. If DB_DIS is set, writes to the DACs in immediate and delayed update mode are neither double-buffered nor deglitched. If DB_DIS is cleared, the DACs are double-buffered and deglitched.
5	CYCLICSTOP	Cyclic Stop Enable—This bit controls when a DAC sequence terminates. If this bit is set when operating the DACs through the FIFO in a cyclic mode, the DAC circuitry will halt when the next end of buffer is encountered. If this bit is clear when the DACs are in a cyclic mode, the DAC circuitry will restart transmission of the buffer after reaching the final point in the buffer. This bit is functional only when the DAC circuitry is in cyclic mode and data is stored exclusively in the DAC FIFO.
4	ADCFIFOREQ	ADC FIFO Request—This bit controls the ADC FIFO Interrupt and DMA Request mode. When ADCFIFOREQ is set, ADC interrupt/DMA requests are generated when the ADC FIFO is half-full. In this case, the request is removed only when the ADC FIFO has been emptied of all its data. When ADCFIFOREQ is cleared, ADC interrupt/DMA requests are generated when a single conversion is available in the FIFO. In this case, the request is removed when the ADC FIFO is empty.
3	SRC3SEL	Source 3 Select—This bit is used to configure the signal connected to Source 3 of the Am9513 Counter/Timer.



		If SRC3SEL is set, Source 3 is connected to the DAC FIFO retransmit signal. In the FIFO programmed cycle waveform modes, this bit should be set so the counter can access to the DAC FIFO retransmit signal. If SRC3SEL is cleared, Source 3 is connected to the SCANCLK signal.
2	GATE2SEL	Gate 2 Select—This bit is used to configure the signal connected to Gate 2 of the Am9513 Counter/Timer. If GATE2SEL is set, Gate 2 is connected to Out 1 of the Am9513. This bit should be set when using the FIFO pulsed waveform generation mode. If GATE2SEL is cleared, Gate 2 is connected to the internal Gate 2 circuitry on the AT-MIO-16X.
1	FIFO/DAC	FIFO or DAC Write Select—This bit controls the destination of writes to the analog output DACs. DMA transfers to the DACs are always buffered by the DAC FIFO. Programmed I/O writes are routed either to the DACs or through the DAC FIFO by using the FIFO/DAC bit. If FIFO/DAC is set, programmed I/O writes to the DACs are buffered by the DAC FIFO. If FIFO/DAC is cleared, programmed I/O writes to the DACs bypass the DAC FIFO and are transmitted directly to the DACs.
0	EXTTRIG_DIS	External Trigger Disable—This bit gates the EXTTRIG* signal from the I/O connector. If EXTTRIG_DIS is set, triggers from EXTTRIG* are ignored by the AT-MIO-16X circuitry. If this bit is cleared, triggers from the EXTTRIG* signal are able to initiate data acquisition sequences.

## Status Register 1

Status Register 1 contains 16 bits of AT-MIO-16X hardware status information, including interrupt, analog input status, analog output status, and data acquisition progress.

**Address:** Base address + 18 (hex)

**Type:** Read-only

**Word Size:** 16-bit

**Bit Map:**

15	14	13	12	11	10	9	8
DAQCOMP	DAQPROG	ADCFIFOHF*	ADCFIFOEF*	DMATCA	DMATCB	OVERFLOW	OVERRUN
MSB							
7	6	5	4	3	2	1	0
TMRREQ	DACCOMP	DAQFIFOFF*	DAQFIFOHF*	DAQFIFOEF*	EEPROMDATA	EEPROMCD*	CFGMEMEF*
LSB							

Bit	Name	Description
15	DAQCOMP	Data Acquisition Complete—This bit reflects the status of the data acquisition termination signal. If DAQCOMP is set and either OVERFLOW or OVERRUN is also set, the current acquisition sequence ended on an error condition. If DAQCOMP is set and neither OVERFLOW nor OVERRUN is set, the data acquisition operation has completed without error. When DAQCOMP is set, and ADCREQ in Command Register 3 is also set, enabled interrupt or DMA requests are generated until the ADC FIFO is empty. DAQCOMP is cleared by strobing the DAQ Clear Register.
14	DAQPROG	Data Acquisition Progress—This bit indicates whether a data acquisition operation is in progress. If DAQPROG is set, a data acquisition operation is in progress. If DAQPROG is cleared, the

		data acquisition operation has completed.
13	ADCFIFOHF*	ADC FIFO Half-Full Flag—This bit reflects the state of the ADC IFO. If the appropriate conversion interrupts are enabled, see Table 4-3, and ADCFIFOHF* is clear, the current interrupt indicates at least 256 A/D conversions are available in the ADC FIFO. To clear the interrupt, read the ADC FIFO until it is empty, ADCFIFOEF* is clear. If ADCFIFOHF* is set, less than 256 ADC conversions are available in the ADC FIFO.
12	ADCFIFOEF*	ADC FIFO Empty Flag—This bit reflects the state of the ADC FIFO. If ADCFIFOEF* is set, one or more A/D conversion results can be read from the ADC FIFO. If the appropriate conversion interrupts are enabled, see Table 4-3, and ADCFIFOEF* is set, the current interrupt indicates that A/D conversion data is available in the ADC FIFO. To clear the interrupt, the FIFO must be read until it is empty. If ADCFIFOEF* is cleared, the ADC FIFO is empty and no conversion interrupt request is asserted.
11	DMATCA	DMA Terminal Count Channel A—DMATCA reflects the status of the DMA process on the selected DMA Channel A. When the DMA operation is completed, DMATCA goes high and remains high until cleared by strobing the DMATCA Clear Register.
10	DMATCB	DMA Terminal Count Channel B—DMATCB reflects the status of the DMA process on the selected DMA Channel B. When the DMA operation is completed, DMATCB goes high and remains high

		until cleared by strobing the DMATCB Clear Register.
9	OVERFLOW	Overflow—This bit indicates whether the ADC FIFO has overflowed during a sample run. OVERFLOW is an error condition that occurs if the FIFO fills up with A/D conversion data and A/D conversions continue. If OVERFLOW is set, A/D conversion data has been lost because of FIFO overflow. If OVERFLOW is clear, no overflow has occurred. If OVERFLOW occurs during a data acquisition operation, the data acquisition is terminated immediately. This bit is reset by strobing the DAQ Clear Register.
8	OVERRUN	Overrun—This bit indicates whether an A/D conversion was initiated before the previous A/D conversion was complete. OVERRUN is an error condition that can occur if the data acquisition sample interval is too small (sample rate is too high). If OVERRUN is set, one or more conversions were skipped. If OVERRUN is clear, no overrun condition has occurred. If OVERRUN occurs during a data acquisition operation, the data acquisition is immediately terminated. This bit is reset by strobing the DAQ Clear Register.
7	TMRREQ	Timer Request—This bit reflects the status of the timer update. TMRREQ is set whenever the DAC FIFO is ready to receive data, or a pulse has occurred on the TMRTRIG* signal in the interrupt mode. TMRREQ generates an interrupt or DMA request only if the proper mode is selected according to Table 4-3. In DMA transfer mode, TMRREQ is automatically cleared when the DAC is written to. In interrupt and programmed

		I/O modes, TMRREQ must be cleared by strobing the TMRREQ Clear Register.
6	DACCOMP	DAC Sequence Complete—This bit reflects the status of the DAC sequence termination circuitry. When the DAC sequence has normally completed, or ended on an error condition, the DACCOMP bit is set. If DACCOMP is set prematurely, this indicates an error condition. If interrupts are enabled, an interrupt will be generated on this condition. The interrupt is serviced by strobing the TMRREQ Clear or DAC Clear Register. While the sequence is in progress, the DACCOMP bit is cleared.
5	DACFIFOFF*	DAC FIFO Full Flag—This bit reflects the state of the DAC FIFO. If DACFIFOFF* is clear, the DAC FIFO is full and is not ready to receive data. If DACFIFOFF* is set, the DAC FIFO is not full and is able to continue receiving data. If the appropriate DAC and I/O modes are enabled, interrupts or DMA requests are generated until the DAC FIFO is full.
4	DACFIFOHF*	DAC FIFO Half Full Flag—This bit reflects the state of the DAC FIFO. If DACFIFOHF* is clear, the DAC FIFO is at least half-full of data. If DACFIFOHF* is set, the DAC FIFO is not half-full of data. If the appropriate DAC and I/O modes are enabled, interrupts or DMA requests are generated when the DAC FIFO is less than half-full.
3	DACFIFOEF*	DAC FIFO Empty Flag—This bit reflects the state of the DAC FIFO. If DACFIFOEF* is clear, the DAC FIFO is empty. If DACFIFOEF* is clear before the last point has been transferred to the

DACs, and DACCOMP is set, this is an error condition and should be handled appropriately. If DACFIFOEF\* is set, then the DAC FIFO has at least one remaining point to be transferred.

- |   |                   |  |
|---|-------------------|--|
| 2 | <b>EEPROMDATA</b> | EEPROM Data—This bit reflects the value of the data shifted out of the EEPROM using SCLK with EEPROMCS enabled.  |
| 1 | <b>EEPROMCD*</b>  | EEPROM Chip Deselect—This bit reflects the status of the EEPROM chip select pin. Because protection circuitry surrounds the EEPROM, having EEPROMCS enabled in Command Register 1 does not necessarily result in the EEPROM being enabled. If EEPROMCD* is low after a mode has been shifted into the EEPROM, an error occurred in shifting in an unsupported mode. To initialize EEPROMCD*, EEPROMCS must be brought low while SCLK is pulsed high. |
| 0 | <b>CFGMEMEF*</b>  | Configuration Memory Empty Flag—This bit indicates the status of the channel configuration memory. If this bit is clear, the channel configuration memory is empty and can be written to. If CFGMEMEF* is set, the channel configuration memory is not empty.  |

## Status Register 2

Status Register 2 contains 1 bit of AT-MIO-16X hardware status information for monitoring the status of the A/D conversion.

**Address:** Base address + 1A (hex)

**Type:** Read-only

**Word Size:** 1-bit

**Bit Map:**

15	14	13	12	11	10	9	8
X	X	X	X	X	X	X	X
MSB							
7	6	5	4	3	2	1	0
X	X	X	X	X	X	X	ADC_BUSY*
LSB							

Bit	Name	Description
15-1	X	Don't care bits.
0	ADC_BUSY*	ADC BUSY—This bit indicates the status of the A/D converter on the AT-MIO-16X during a conversion or calibration process. The A/D converter on the AT-MIO-16X can calibrate its internal circuitry on command by strobing the ADC Calibration Register. If ADC_BUSY* is clear, an ADC conversion or calibration operation is currently in progress. If ADC_BUSY* is set, no ADC conversion or calibration operation is in progress. An ADC calibration cycle takes approximately 1.25 sec. During this time, the ADC is busy as reflected by the ADC_BUSY* status, and cannot be used.

## Analog Input Register Group

The two registers making up the Analog Input Register Group control the analog input circuitry and can be used to read the ADC FIFO. Reading from the ADC FIFO Register location transfers data from the AT-MIO-16X ADC FIFO buffer to the PC. Writing to the CONFIGMEM Register location sets up channel configuration information for the analog input section. This information is necessary for single conversions as well as single- and multiple-channel data acquisition sequences.

Bit descriptions of the two registers making up the Analog Input Register Group are given on the following pages.



## ADC FIFO Register

Reading the ADC FIFO Register returns the oldest ADC conversion value stored in the ADC FIFO. Whenever the ADC FIFO is read, the value read is removed from the ADC FIFO, thereby leaving space for another ADC conversion value to be stored. Values are shifted into the ADC FIFO whenever an ADC conversion is complete.

The ADC FIFO is emptied when all values it contains are read. Status Register 1 should be read to determine the FIFO state before the ADC FIFO Register is read. If the ADC FIFO contains one or more ADC conversion values, the ADCFIFOEF\* bit is set in Status Register 1 and the ADC FIFO Register can be read to retrieve a value. If the ADCFIFOEF\* bit is cleared, the ADC FIFO is empty, in which case reading the ADC FIFO Register returns meaningless information. If the ADCFIFOHF\* flag is clear in Status Register 1, the ADC FIFO is at least half-full with conversion data, and 256 FIFO values can be read without checking the ADCFIFOEF\* in Status Register 1.

The values returned by reading the ADC FIFO Register are available in two different binary formats: straight binary, which generates only positive numbers, or two's complement binary, which generates both positive and negative numbers. The binary format used is determined by the mode in which the ADC is configured. The bit pattern returned for either format is given as follows:

**Address:** Base address + 00 (hex)

**Type:** Read-only

**Word Size:** 16-bit

**Bit Map:**

15	14	13	12	11	10	9	8	7	6	5	4	3	2	1	0
D15	D14	D13	D12	D11	D10	D9	D8	D7	D6	D5	D4	D3	D2	D1	D0

MSB LSB

Bit	Name	Description
15-0	D<15..0>	Local data bus bits. When the ADC FIFO is addressed, these bits are the result of a 16-bit ADC conversion. Values read range from 0 to 65,535 decimal (0x0000 to 0xFFFF) when the ADC is in unipolar mode, and -32,768 to 32,767 decimal

(0x8000 to 0x7FFF) when the ADC is in bipolar mode.

The A/D conversion result can be returned from the ADC FIFO as a two's complement or straight binary value depending on the input mode set by the CHAN\_BIP bit in the configuration memory location for the converted channel. If the analog input circuitry is configured for the input range 0 to +10 V, straight binary format is implemented. Straight binary format returns numbers between 0 and 65,535 (decimal) when the ADC FIFO Register is read. If the analog input circuitry is configured for the input ranges -10 to +10 V, two's complement format is used. Two's complement format returns numbers between -32,768 and +32,767 (decimal) when the ADC FIFO Register is read. Table 4-7 shows input voltage versus A/D conversion value for straight binary format and 0 to +10 V input range. Table 4-8 shows input voltage versus A/D conversion value for two's complement format for -10 to +10 V input range.

**Table 4-7.** Straight Binary Mode A/D Conversion Values

Input Voltage (Gain = 1)	A/D Conversion Result Range: 0 to 10 V	
	Decimal	Hex
0.0 V	0	0000
152.6 $\mu$ V	1	0001
2.5 V	16,384	4000
5.0 V	32,768	8000
7.5 V	49,152	C000
9.999847 V	65,535	FFFF

To convert from the ADC FIFO value to the input voltage measured, use the following formula:

$$V = \frac{\text{ADC reading}}{65,536} * \frac{10 \text{ V}}{\text{Gain}}$$

**Table 4-8.** Two's Complement Mode A/D Conversion Values

Input Voltage (Gain = 1)	A/D Conversion Result Range: -10 to +10 V	
	Decimal	Hex
-10.0 V	-32,768	8000
-9.999695 V	-32,767	8001
-5.0 V	-16,384	C000
-305.2 $\mu$ V	-1	FFFF
0.0 V	0	0000
305.2 $\mu$ V	1	0001
5.0 V	16,384	4000
9.999695 V	32,767	7FFF

To convert from the ADC FIFO value to the input voltage measured, use the following formula:

$$V = \frac{\text{ADC reading}}{32,768} * \frac{10 \text{ V}}{\text{Gain}}$$

## CONFIGMEM Register

The CONFIGMEM Register controls the input channel-selection multiplexers, gain, range, and mode settings, and can contain up to 512 channel configuration settings for use in scanning sequences.

**Address:** Base address + 08 (hex)

**Type:** Write-only

**Word Size:** 16-bit

**Bit Map:**

15	14	13	12	11	10	9	8
CHAN_SE	CHAN_AIS	CHAN_CAL	CHAN_BIP	0	0	CHANSEL3	CHANSEL2
MSB							
7	6	5	4	3	2	1	0
CHANSEL1	CHANSEL0	CH_GAIN2	CH_GAIN1	CH_GAIN0	CHAN_LAST	CHAN_GHOST	CHAN_DSP
LSB							

Bit	Name	Description
15	CHAN_SE	Channel Single-Ended—This bit configures the analog input section for single-ended or differential mode. See Table 4-9.
14	CHAN_AIS	Channel Analog Input Sense—This bit sets the analog input section for RSE or NRSE mode when CHAN_CAL is cleared. When CHAN_CAL is set, this bit controls the reference signal connected to the positive (+) side of the PGIA for calibration purposes. See Table 4-9.
13	CHAN_CAL	Channel Calibration Enable—This bit controls the analog input configuration switches. CHAN_CAL is used to disconnect the input multiplexers from the PGIA during a calibration procedure so that known internal reference signals can be routed to the amplifier. See Table 4-9.

- 12            **CHAN\_BIP**            Channel Bipolar—This bit configures the ADC for unipolar or bipolar mode. When **CHAN\_BIP** is clear, the ADC is configured for unipolar operation and values read from the ADC FIFO are in straight binary format. When **CHAN\_BIP** is set, the ADC is configured for bipolar operation and values. The FIFO values are two's complement and automatically sign extended.
- 11-10        0                            Reserved—These bits must always be set to zero.
- 9-6            **CHANSEL<3..0>**            Input Channel Select—These four bits control the input multiplexer address setting for selecting the analog input channel routed to the ADC. In single-ended mode, only one analog input channel is selected. In differential mode, two analog input channels are selected. The following table shows the mapping of analog input channels in the different input configurations.

<b>CHANSEL&lt;3..0&gt;</b>	<b>Selected Analog Input Channels</b>	
	<b>Single-Ended</b>	<b>Differential (+) (-)</b>
0000	0	0 and 8
0001	1	1 and 9
0010	2	2 and 10
0011	3	3 and 11
0100	4	4 and 12
0101	5	5 and 13
0110	6	6 and 14

CHANSEL<3..0>	Selected Analog Input Channels	
	Single-Ended	Differential (+) (-)
0111	7	7 and 15
1000	8	0 and 8
1001	9	1 and 9
1010	10	2 and 10
1011	11	3 and 11
1100	12	4 and 12
1101	13	5 and 13
1110	14	6 and 14
1111	15	7 and 15

5-3 CH\_GAIN<2..0> Channel Gain Select—These three bits control the gain setting of the input PGIA for the selected channel. The following gains can be selected on the AT-MIO-16X:

CH_GAIN<2..0>	Actual Gain
000	N/A
001	1
010	2
011	5
100	10
101	20

<b>CH_GAIN&lt;2..0&gt;</b>	<b>Actual Gain</b>
110	50
111	100

- 2            **CHAN\_LAST**    Channel Last—This bit should be set in the last entry of the scan sequence loaded into the channel configuration memory. More than one occurrence of the CHAN\_LAST bit is possible in the configuration memory list for the interval-scanning mode. For example, there can be multiple scan sequences in one memory list.
- 1            **CHAN\_GHOST**    Channel Ghost—This bit is used to synchronize conversion for multiple-rate channel scanning. When this bit is set in any channel configuration value, the conversion occurs on the selected channel but the value is not saved in the ADC FIFO. In addition, if the sample counter is programmed to count samples from Source 4, conversions with the CHAN\_GHOST bit set are not counted. When the CHAN\_GHOST bit is clear, conversions occur normally and are saved in the ADC FIFO.
- 0            **CHAN\_DSP**        Channel DSP—This bit is used to flag channel data that is to be serially sent over the RTSI bus to the AT-DSP2200. If the CHAN\_DSP bit is set, the associated channel conversion data is sent over the RTSI bus. If CHAN\_DSP is clear, channel conversion data is not sent. The CHAN\_DSP bit has no bearing on whether or not the channel conversion data is stored in the ADC FIFO. That is controlled by the CHAN\_GHOST bit.

**Table 4-9.** Input Configuration

Input Mode	Bit Map			Effect	
	CHAN_CAL	CHAN_SE	CHAN_AIS	PGIA (+)	PGIA (-)
DIFF	0	0	X	Channels 0 to 7	Channels 8 to 15
RSE	0	1	0	Channels 0 to 15	AI GND
NRSE	0	1	1	Channels 0 to 15	AI SENSE
Offset Calibration	1	X	0	AI GND	AI GND
Gain Calibration	1	X	1	Internal +5 V <sub>ref</sub>	AI GND
<b>Note:</b> X indicates a <i>don't care</i> bit.					

Writing to the channel configuration memory must be preceded with a strobe to the CONFIGMEMCLR Register. After the channel configuration memory is set up, the first value must be preloaded by accessing the CONFIGMEMLD Register. Writing to the CONFIGMEM Register following a CONFIGMEMCLR automatically sequences into the memory list for multiple-channel configuration values. Writing can continue until the end of the channel configuration list is reached, or the memory becomes full. After the final write to the channel configuration memory, the CONFIGMEMLD Register should be strobed to load the first channel configuration value. At this point, the channel configuration memory is primed and does not need to be accessed again until a new channel configuration sequence is desired.

Conversions, either by EXTCONV\* or by Counter 3 of the Am9513A Counter/Timer, automatically sequence through the channel configuration memory as programmed. When the end of the channel configuration memory is detected, it is automatically reset to the first value in the list. Strobing the DAQ Clear Register also resets the channel configuration memory to the first value in the list without destroying existing channel configuration values. A strobe of the CONFIGMEMLD Register is still necessary to load the first value in the memory.



Continual strobing of the CONFIGMEMLD Register with only one value in the list serves only to reload this one value. Continual strobing with more than one value in the memory sequences through the channel configuration list.

In the single-channel data acquisition mode, only one value should be written and loaded into the channel configuration register.

## Analog Output Register Group

The two registers making up the Analog Output Register Group access the two analog output channels. Data can be transferred to the DACs in one of three ways depending on the mode configuration in Command Register 4 according to Table 4-6. Data can be directly sent to the DACs from the local data bus, buffered from the local bus by the DAC FIFOs, or received serially from the AT-DSP2200 across the RTSI bus. There are two methods of updating the DACs, immediate and posted. In the immediate update mode, data transferred to the DACs is not buffered, and is immediately converted to the appropriate voltage at the output. In the posted update mode, data is converted to an output voltage only after a falling edge is detected on the TMRTRIG\* signal, or the DAC Update Register is strobed. In the immediate update mode and the serial mode, the DAC FIFOs are not utilized. In all other output modes, the DAC FIFOs are used.

The output voltage generated from the digital code depends on the configuration, unipolar or bipolar, of the associated analog output channel. This configuration is determined by control bits in the Command Register 2. Configuration bits in Command Register 2 determine if the digital code written to the DACs is in straight binary form or in a two's complement form. Table 4-10 shows the output voltage versus digital code for a unipolar analog output configuration. Table 4-11 shows the voltage versus digital code for a bipolar analog output configuration.

The formula for the voltage output versus digital code for a unipolar analog output configuration is as follows:

$$V_{\text{out}} = V_{\text{ref}} * \frac{(\text{digital code})}{65,536}$$

where  $V_{\text{ref}}$  is the reference voltage applied to the analog output channel. The digital code in the above formula is a decimal value ranging from 0 to 65,535.

**Table 4-10.** Analog Output Voltage Versus Digital Code (Unipolar Mode)

Digital Code		Voltage Output
Decimal	Hex	$V_{\text{ref}} = 10 \text{ V}$
0	0000	0.0 V
1	0001	152.6 $\mu\text{V}$
16,384	4000	2.5 V
32,768	8000	5.0 V
49,152	C000	7.5 V
65,535	FFFF	9.999847 V

The formula for the voltage output versus digital code for a bipolar analog output configuration in two's complement form is as follows:

$$V_{\text{out}} = V_{\text{ref}} * \frac{(\text{digital code})}{32,768}$$

where  $V_{\text{ref}}$  is the positive reference voltage applied to the analog output channel. The digital code in the preceding formula is a decimal value ranging from  $-32,768$  to  $+32,767$ .

**Table 4-11.** Analog Output Voltage Versus Digital Code (Bipolar Mode)

Digital Code		Voltage Output
Decimal	Hex	Reference = 10 V
$-32,768$	8000	$-10.0 \text{ V}$
$-32,767$	8001	$-9.999695 \text{ V}$
$-16,384$	C000	$-5.0 \text{ V}$
$-1$	FFFF	$-305.2 \mu\text{V}$
0	0000	0.0 V
1	0001	305.2 $\mu\text{V}$

**Table 4-11.** Analog Output Voltage Versus Digital Code (Bipolar Mode) (Continued)

<b>Digital Code</b>		<b>Voltage Output</b>
<b>Decimal</b>	<b>Hex</b>	<b>Reference = 10 V</b>
16,384	4000	5.0 V
32,767	7FFF	9.999695 V

Bit descriptions for the registers making up the Analog Output Register Group are given on the following pages.

## DAC0 Register

Writing to the DAC0 Register loads the value written to the analog output DAC Channel 0 in immediate update mode. If posted update mode is used, the value written to the DAC0 Register is buffered and updated to the analog output DAC Channel 0 only after an access to the DAC Update Register or a timer trigger is received in one of the prescribed paths.

**Address:** Base address + 10 (hex)

**Type:** Write-only

**Word Size:** 16-bit

**Bit Map:**

15	14	13	12	11	10	9	8	7	6	5	4	3	2	1	0
D15	D14	D13	D12	D11	D10	D9	D8	D7	D6	D5	D4	D3	D2	D1	D0
MSB															LSB

Bit	Name	Description
15-0	D<15..0>	Data bus to the analog output DACs. The data written to the DACs is interpreted in straight binary form when DAC Channel 0 is configured for unipolar operation. When DAC Channel 0 is configured for bipolar operation, the data is interpreted in two's complement form.

## DAC1 Register

Writing to the DAC1 Register loads the value written to the analog output DAC Channel 1 in immediate update mode. If posted update mode is used, the value written to the DAC1 Register is buffered and updated to the analog output DAC Channel 1 only after an access to the DAC Update Register or a timer trigger is received in one of the prescribed paths.

**Address:** Base address + 12 (hex)

**Type:** Write-only

**Word Size:** 16-bit

### Bit Map:

15	14	13	12	11	10	9	8	7	6	5	4	3	2	1	0
D15	D14	D13	D12	D11	D10	D9	D8	D7	D6	D5	D4	D3	D2	D1	D0
MSB														LSB	

Bit	Name	Description
15-0	D<15..0>	Data bus to the analog output DACs. The data written to the DACs is interpreted in straight binary form when DAC Channel 1 is configured for unipolar operation. When DAC Channel 1 is configured for bipolar operation, the data is interpreted in two's complement form.

## ADC Event Strobe Register Group

The ADC Event Strobe Register Group consists of six registers that, when written to, cause the occurrence of certain events on the AT-MIO-16X board, such as clearing flags and starting A/D conversions.

Bit descriptions of the six registers making up the ADC Event Strobe Register Group are given on the following pages.

## CONFIGMEMCLR Register

Accessing the CONFIGMEMCLR Register clears all information in the channel configuration memory and resets the write pointer to the first location in the memory.

<b>Address:</b>	Base address + 1B (hex)
<b>Type:</b>	Read-only
<b>Word Size:</b>	8-bit
<b>Bit map:</b>	Not applicable, no bits used
<b>Strobe Effect:</b>	Clears the channel configuration memory

Before the channel configuration memory is written to, it must be cleared of its existing information and reset to an initialized state. This process is accomplished by accessing the CONFIGMEMCLR Register. Once the existing channel configuration values are cleared, they are not recoverable. At this point, the channel configuration memory is ready to be filled with valid information.



## CONFIGMEMLD Register

Accessing the CONFIGMEMLD Register loads and sequences through the channel configuration memory.

**Address:** Base address + 1B (hex)

**Type:** Write-only

**Word Size:** 8-bit

**Bit Map:** Not applicable, no bits used

**Strobe Effect:** Read and apply a channel configuration value to the analog input section

Accessing the CONFIGMEMLD Register loads the channel configuration memory values and applies the first channel configuration value to the analog input circuitry. After the final write to the channel configuration memory, accessing the CONFIGMEMLD Register loads the first channel configuration value. Writing to the CONFIGMEMLD Register again loads the second channel configuration value, and so on.

Strobing the DAQ Clear Register resets the channel configuration memory to the first value, but does not load the value. This does not clear the memory of any values written to it prior to the DAQ Clear strobe. After strobing the DAQ Clear Register, the CONFIGMEMLD Register should be strobed to load the first value. A scanned data acquisition can be initiated from any location in the channel configuration memory by using this method.

## DAQ Clear Register

Accessing the DAQ Clear Register location clears the data acquisition circuitry.

<b>Address:</b>	Base address + 19 (hex)
<b>Type:</b>	Read-only
<b>Word Size:</b>	8-bit
<b>Bit Map:</b>	Not applicable, no bits used
<b>Strobe Effect:</b>	Cancels any data acquisition operation in progress, empties the ADC FIFO, clears the OVERRUN bit in Status Register 1, clears the OVERFLOW bit in Status Register 1, clears the DAQCOMP bit in Status Register 1, clears any pending ADC interrupt, and resets the configuration memory to the initial value (no values are lost)



**Note:** *If the channel configuration memory contains valid information and no new values are to be added before restarting the data acquisition sequence, the CONFIGMEMLD Register should be strobed following a DAQ Clear strobe.*

## DAQ Start Register

Accessing the DAQ Start Register location initiates a multiple A/D conversion data acquisition operation.



**Note:** *Several other pieces of AT-MIO-16X circuitry must be set up before a data acquisition run can occur. See Chapter 5, Programming.*

**Address:** Base address + 1D (hex)

**Type:** Read-only

**Word Size:** 8-bit

**Bit Map:** Not applicable, no bits used

**Strobe Effect:** Initiates a programmed data acquisition sequence



**Note:** *Multiple A/D conversion data acquisition operations can be initiated in one of three ways—by accessing the Start DAQ Register, or by detecting an active-low signal on either the EXTTRIG\* or the RTSITRIG\* signal. To trigger the board with the Start DAQ Register, the RTSITRIG signal in Command Register 1 must be cleared. In addition, either the EXTTRIG\* signal should be unasserted, or the EXTTRIG\_DIS signal in Command Register 4 must be set. Otherwise, strobing the Start DAQ Register has no effect.*

## Single Conversion Register

Accessing the Single Conversion Register location initiates a single A/D conversion.

<b>Address:</b>	Base address + 1D (hex)
<b>Type:</b>	Write-only
<b>Word Size:</b>	8-bit
<b>Bit Map:</b>	Not applicable, no bits used
<b>Strobe Effect:</b>	Initiates a single ADC conversion

**Note:**

*A/D conversions can be initiated in one of two ways—by accessing the Single Conversion Register or by applying an active-low signal on the EXTCONV\* signal. The EXTCONV\* signal is connected to the I/O connector, to OUT3 of the Am9513A, and to the A0 pin of the RTSI bus switch. If the Single Conversion Register is to initiate A/D conversions, all other sources of conversion should be inhibited to avoid an OVERRUN condition.*

## ADC Calibration Register

Accessing the ADC Calibration Register location initiates an ADC calibration procedure. This register should be strobed after power up to assure the ADC is in a calibrated state.

**Address:** Base address + 1F (hex)

**Type:** Write-only

**Word Size:** 8-bit

**Bit Map:** Not applicable, no bits used

**Strobe Effect:** Initiates an ADC-level calibration (not a system-level calibration)



**Note:**

*The ADC\_BUSY\* signal in Status Register 2 should be monitored to determine when the AT-MIO-16X ADC calibration cycle is finished. The calibration cycle takes approximately 1.25 sec to complete. All other conversions must be inhibited until the ADC calibration cycle is completed. After the calibration cycle, the ADC must be initialized by generating a conversion. The Single Conversion Register should be accessed to start an A/D conversion. After the conversion is completed, the result will be stored in the ADC FIFO. Because this data is meaningless, it must be cleared by reading the value from the FIFO or accessing the DAQ Clear Register.*

## DAC Event Strobe Register Group

The DAC Event Strobe Register Group consists of three registers that, when written to, cause the occurrence of certain events on the AT-MIO-16X board, such as clearing flags and updating the analog output DACs.

Bit descriptions of the three registers making up the DAC Event Strobe Register Group are given on the following pages.

## TMRREQ Clear Register

Accessing the TMRREQ Clear Register clears the TMRREQ and DACCOMP bits after a TMRTRIG\* pulse is detected. Clearing TMRREQ when interrupt or DMA mode is enabled clears the respective interrupt or DMA request.

<b>Address:</b>	Base address + 1F (hex)
<b>Type:</b>	Read-only
<b>Word Size:</b>	8-bit
<b>Bit Map:</b>	Not applicable, no bits used
<b>Strobe Effect:</b>	Clears the TMRREQ signal in Status Register 1 and its associated interrupts, and clears the DAC COMP signal in Status Register 1 and its associated interrupt

The analog output DACs can be updated internally and externally in the waveform generation mode through the control of A4RCV. If A4RCV is enabled, internal updating is selected and any signal from the RTSI switch can control the updating interval. If OUT2 is to be used for updating the DACs, A2DRV must also be enabled. If OUT5 is to be used, A4DRV must be enabled as well. If A4RCV is disabled, external updating is selected and the EXTMRTRIG\* signal from the I/O connector is used for updating.

In all cases, a falling edge on the selected signal triggers the updating mechanism in posted update mode. This trigger also sets the TMRREQ bit in Status Register 1 and generates an interrupt or DMA request if so enabled.

## DAC Update Register

Accessing the DAC Update Register with posted update mode enabled updates both DAC0 and DAC1 simultaneously with the previously written values and removes DAC FIFO data for DAC0, DAC1, or both, as programmed.

<b>Address:</b>	Base address + 18 (hex)
<b>Type:</b>	Write-only
<b>Word Size:</b>	16-bit
<b>Bit Map:</b>	Not applicable, no bits used.
<b>Strobe Effect:</b>	Updates latched DAC values to the DAC Register in posted update mode, sets the TMRREQ signal in Status Register 1, and generates an interrupt or DMA request if enabled



## DAC Clear Register

Accessing the DAC Clear Register clears parts of the DAC circuitry, including emptying the DAC FIFO.

**Address:** Base address + 1E (hex)

**Type:** Read-only

**Word Size:** 8-bit

**Bit Map:** Not applicable, no bits used

**Strobe Effect:** Empties the DAC FIFO, clears the TMRREQ bit in Status Register 1 and its associated interrupts, and clears the DACCOMP bit in Status Register 1 and its associated interrupts

## General Event Strobe Register Group

The General Event Strobe Register Group consists of six registers that, when written to, cause the occurrence of certain events on the AT-MIO-16X board, such as clearing flags and starting A/D conversions.

Bit descriptions of the six registers making up the General Event Strobe Register Group are given on the following pages.

## DMA Channel Clear Register

Accessing the DMA Channel Clear Register clears the circuitry associated with dual-channel DMA operation. Two DMA channels are programmed for dual channel DMA. When the first DMA channel terminal count is reached, the circuitry automatically sequences the second DMA channel. When the second DMA channel terminal count is reached, the circuitry returns to the first DMA channel for servicing. The effect of the DMA channel Clear Register is to initialize this circuitry.

<b>Address:</b>	Base address + 0B (hex)
<b>Type:</b>	Read-only
<b>Word Size:</b>	8-bit
<b>Bit Map:</b>	Not applicable, no bits used
<b>Strobe Effect:</b>	Clears the dual DMA channel circuitry (dual DMA mode only)

## DMATCA Clear Register

Accessing the DMATCA Clear Register will clear the DMATCA signal in Status Register 1, and it will acknowledge the interrupt generated from the Channel A terminal counter interrupt. When the selected DMA Channel A reaches its terminal count, the DMATCA signal in the Status Register is asserted. If DMATC interrupts are enabled, an interrupt will also be generated.

**Address:** Base address + 19 (hex)

**Type:** Write-only

**Word Size:** 8-bit

**Bit Map:** Not applicable, no bits used

**Strobe Effect:** Clears the DMATCA signal in Status Register 1, and acknowledges an interrupt from a DMA Channel A terminal count

## DMATCB Clear Register

Accessing the DMATCB Clear Register clears the DMATCB signal in Status Register 1, and acknowledges the interrupt generated from the Channel B terminal counter interrupt. When the selected DMA Channel B terminal count is reached, the DMATCB signal in Status Register 1 is asserted. If DMATC interrupts are enabled, an interrupt will also be generated.

**Address:** Base address + 09 (hex)

**Type:** Read-only

**Word Size:** 8-bit

**Bit Map:** Not applicable, no bits used

**Strobe Effect:** Clears the DMATCB signal in Status Register 1, and acknowledges an interrupt from a DMA Channel B terminal count

## External Strobe Register

Accessing the External Strobe Register location generates an active low signal at the EXTSTROBE\* output of the I/O connector. This signal has a minimum low time of 500 nsec. The EXTSTROBE\* pulse is useful for several applications, including generating external general-purpose triggers and latching data into external devices, for example, from the digital output port.

<b>Address:</b>	Base address + 1E (hex)
<b>Type:</b>	Write-only
<b>Word Size:</b>	8-bit
<b>Bit Map:</b>	Not applicable, no bits used
<b>Strobe Effect:</b>	Generates an active-low pulse at the I/O connector of at least 500-nsec duration

## Calibration DAC 0 Load Register

Accessing the Calibration DAC 0 Load Register loads the serial data previously shifted into one of the eight selected 8-bit calibration DACs.

**Address:** Base address + 0A (hex)

**Type:** Write-only

**Word Size:** 8-bit

**Bit Map:** Not applicable, no bits used

**Strobe Effect:** Updates a selected calibration DAC

## Calibration DAC 1 Load Register

Accessing the Calibration DAC 1 Load Register loads the serial data shifted into the 12-bit ADC pregain offset calibration DACs.

<b>Address:</b>	Base address + 1A (hex)
<b>Type:</b>	Write-only
<b>Word Size:</b>	8-bit
<b>Bit Map:</b>	Not applicable, no bits used
<b>Strobe Effect:</b>	Updates the ADC pregain offset calibration DAC



## Am9513A Counter/Timer Register Group

The three registers making up the Am9513A Counter/Timer Register Group access the onboard counter/timer. The Am9513A controls onboard data acquisition timing as well as general-purpose timing for the user.

The Am9513A registers described here are the Am9513A Data Register, the Am9513A Command Register, and the Am9513A Status Register. The Am9513A contains 18 additional internal registers. These internal registers are accessed through the Am9513A Data Register. A detailed register description of all Am9513A registers is included in Appendix C, *AMD Am9513A Data Sheet*.

Bit descriptions for the Am9513A Counter/Timer Register Group registers are given in the following pages.

## Am9513A Data Register

With the Am9513A Data Register, any of the 18 internal registers of the Am9513A can be written to or read from. The Am9513A Command Register must be written to in order to select the register to be accessed by the Am9513A Data Register. The internal registers accessed by the Am9513A Data Register are as follows:

- Counter Mode Registers for Counters 1, 2, 3, 4, and 5
- Counter Load Registers for Counters 1, 2, 3, 4, and 5
- Counter Hold Registers for Counters 1, 2, 3, 4, and 5
- The Master Mode Register
- The Compare Registers for Counters 1 and 2

All these registers are 16-bit registers. Bit descriptions for each of these registers are included in Appendix C, *AMD Am9513A Data Sheet*.

**Address:** Base address + 14 (hex)

**Type:** Read-and-write

**Word Size:** 16-bit

**Bit Map:**

15	14	13	12	11	10	9	8	7	6	5	4	3	2	1	0
D15	D14	D13	D12	D11	D10	D9	D8	D7	D6	D5	D4	D3	D2	D1	D0
MSB															LSB

Bit	Name	Description
15-0	D<15..0>	These 16 bits are loaded into the Am9513A Internal Register currently selected. See Appendix C, <i>AMD Am9513A Data Sheet</i> , for the detailed bit descriptions of the 18 registers accessed through the Am9513A Data Register.

## Am9513A Command Register

The Am9513A Command Register controls the overall operation of the Am9513A Counter/Timer and controls selection of the internal registers accessed through the Am9513A Data Register.

**Address:** Base address + 16 (hex)

**Type:** Write-only

**Word Size:** 16-bit

**Bit Map:**

15	14	13	12	11	10	9	8	7	6	5	4	3	2	1	0
1	1	1	1	1	1	1	1	C7	C6	C5	C4	C3	C2	C1	C0
MSB														LSB	

Bit	Name	Description
15-8	1	These bits must always be set when writing to the Am9513A Command Register.
7-0	C<7..0>	These eight bits are loaded into the Am9513A Command Register. See Appendix C, <i>AMD Am9513A Data Sheet</i> , for the detailed bit description of the Am9513A Command Register.

## Am9513A Status Register

The Am9513A Status Register contains information about the output pin status of each counter in the Am9513A.

**Address:** Base address + 16 (hex)

**Type:** Read-only

**Word Size:** 16-bit

**Bit Map:**

15	14	13	12	11	10	9	8
X	X	X	X	X	X	X	X
MSB							
7	6	5	4	3	2	1	0
X	X	OUT5	OUT4	OUT3	OUT2	OUT1	BYTEPTR
LSB							

Bit	Name	Description
15-6	X	Don't care bits.
5-1	OUT<5..1>	Each of these five bits returns the logic state of the associated counter output pin. For example, if OUT4 is set, then the output pin of Counter 4 is at a logic high state.
0	BYTEPTR	This bit represents the state of the Am9513A Byte Pointer Flip-Flop. This bit has no significance for AT-MIO-16X operation because the Am9513A should always be used in 16-bit mode on the AT-MIO-16X.

## Digital I/O Register Group

The two registers making up the Digital I/O Register Group monitor and control the AT-MIO-16X digital I/O lines. The Digital Input Register returns the digital state of the eight digital I/O lines. A pattern written to the Digital Output Register is driven onto the digital I/O lines when the digital output drivers are enabled (see the description for Command Register 2).

Bit descriptions of the two registers making up the Digital I/O Register Group are given on the following pages.

## Digital Input Register

The Digital Input Register, when read, returns the logic state of the eight AT-MIO-16X digital I/O lines.

**Address:** Base address + 1C (hex)

**Type:** Read-only

**Word Size:** 16-bit

**Bit Map:**

15	14	13	12	11	10	9	8
X	X	X	X	X	X	X	X
MSB							
7	6	5	4	3	2	1	0
BDIO3	BDIO2	BDIO1	BDIO0	ADIO3	ADIO2	ADIO1	ADIO0
LSB							

Bit	Name	Description
15-8	X	Don't care bits.
7-4	BDIO<3..0>	These four bits represent the logic state of the digital lines BDIO<3..0>.
3-0	ADIO<3..0>	These four bits represent the logic state of the digital lines ADIO<3..0>.

## Digital Output Register

Writing to the Digital Output Register controls the eight AT-MIO-16X digital I/O lines. The Digital Output Register controls both ports A and B. When either digital port is enabled, the pattern contained in the Digital Output Register is driven onto the lines of the digital port.

**Address:** Base address + 1C (hex)

**Type:** Write-only

**Word Size:** 16-bit

**Bit Map:**

15	14	13	12	11	10	9	8
0	0	0	0	0	0	0	0
MSB							
7	6	5	4	3	2	1	0
BDIO3	BDIO2	BDIO1	BDIO0	ADIO3	ADIO2	ADIO1	ADIO0
LSB							

Bit	Name	Description
15-8	0	Reserved
7-4	BDIO<3..0>	These four bits control the digital lines BDIO<3..0>. The bit DIOPBEN in Command Register 2 must be set for BDIO<3..0> to be driven onto the digital lines BDIO<3..0>.
3-0	ADIO<3..0>	These four bits control the digital lines ADIO<3..0>. The bit DIOPAEN in Command Register 2 must be set for ADIO<3..0> to be driven onto the digital lines ADIO<3..0>.

## **RTSI Switch Register Group**

The two registers making up the RTSI Switch Register Group, allow the AT-MIO-16X RTSI switch to be programmed for routing of signals on the RTSI bus trigger lines to and from several AT-MIO-16X signal lines. The RTSI switch is programmed by shifting a 56-bit routing pattern into the RTSI switch and then loading the internal RTSI Switch Control Register. The routing pattern is shifted into the RTSI switch by writing one bit at a time to the RTSI Switch Shift Register. The RTSI Switch Control Register is then loaded by writing to the RTSI Switch Strobe Register.

Bit descriptions of the two registers making up the RTSI Switch Register Group are given on the following pages.



## RTSI Switch Shift Register

The RTSI Switch Shift Register is written to in order to load the RTSI switch internal 56-bit Control Register with routing information for switching signals to and from the RTSI bus trigger lines. The RTSI Switch Shift Register is a 1-bit register and must be written to 56 times to shift the 56 bits into the internal register.

**Address:** Base address + 0C (hex)

**Type:** Write-only

**Word Size:** 8-bit

**Bit Map:**

7	6	5	4	3	2	1	0
0	0	0	0	0	0	0	RSI

LSB

Bit	Name	Description
7-1	0	Reserved
0	RSI	RTSI Switch Serial Input—This bit is the serial input to the RTSI switch. Each time the RTSI Switch Shift Register is written to, the value of this bit is shifted into the RTSI switch. See the <i>Programming the RTSI Switch</i> section in Chapter 5, <i>Programming</i> , for more information.

## RTSI Switch Strobe Register

The RTSI Switch Strobe Register is written to in order to load the contents of the RTSI Switch Shift Register into the RTSI Switch Control Register, thereby updating the RTSI switch routing pattern. The RTSI Switch Strobe Register is written to after shifting the 56-bit routing pattern into the RTSI Switch Shift Register.

**Address:** Base address + 0E (hex)

**Type:** Write-only

**Word Size:** 8-bit

**Bit Map:** Not applicable, no bits used

# Programming

---

Chapter

5

This chapter contains programming instructions for operating the circuitry on the AT-MIO-16X.

Programming the AT-MIO-16X involves writing to and reading from the various registers on the board. The programming instructions list the sequence of steps to take. The instructions are language independent; that is, they instruct you to write a value to a given register, to set or clear a bit in a given register, or to detect whether a given bit is set or cleared without presenting the actual code.



**Note:**

*If you plan to use a programming software package such as NI-DAQ or LabWindows/CVI with your AT-MIO-16X board, you need not read this chapter.*

## Register Programming Considerations

Several write-only registers on the AT-MIO-16X contain bits that control a number of independent pieces of the onboard circuitry. In the instructions for setting or clearing bits, specific register bits should be set or cleared without changing the current state of the remaining bits in the register. However, writing to these registers simultaneously affects all register bits. You cannot read these registers to determine which bits have been set or cleared in the past; therefore, you should maintain a software copy of the write-only registers. This software copy can then be read to determine the status of the write-only registers. To change the state of a single bit without disturbing the remaining bits, set or clear the bit in the software copy and write the software copy to the register.

## Resource Allocation Considerations

Counters 1, 2, and 5 of the Am9513A Counter/Timer are available at the I/O connector for general-purpose use. These counters can only be used so long as this does not conflict with an internal operation in progress on the board that is already using the desired counter. Table 5-1 lists the five counters in the Am9513A Counter/Timer and enumerates what they are used for in each operation.

**Table 5-1.** Am9513A Counter/Timer Allocations

Counter	DAQ Operation	Waveform Operation
1	Scan division	Updating/cycle counting/pulsed waveform
2	Scan division	Updating/cycle counting/pulsed waveform
3	Sample interval	Updating
4	Sample count	N/A
5	Sample count (> 65,536)	Updating/cycle counting

Table 5-1 provides a general overview of the AT-MIO-16X resources to ensure there are no conflicts when using the counters/timers. As an example, if an interval scanning data acquisition sequence that requires less than 65,537 samples is in operation, Counters 2, 3, and 4 of the Am9513A are reserved for this purpose. This leaves Counters 1 and 5 available for general-purpose or waveform generation use.

## Initializing the AT-MIO-16X

The AT-MIO-16X hardware must be initialized for the AT-MIO-16X circuitry to operate properly. To initialize the AT-MIO-16X hardware, complete the following steps:

1. Write 0 to Command Registers <1..4>.
2. Access the following strobe registers:
  - CONFIGMEMCLR Register
  - DAQ Clear Register
  - DMATC A and B Clear Registers
  - DMA Channel Clear Register
  - DAC Clear Register
  - TMRREQ Clear Register
  - ADC Calibration Register
3. Initialize the Am9513A (see *Initializing the Am9513A* section later in this chapter).

4. Disable all RTSI switch connections (see *Programming the RTSI Switch* section later in this chapter).

This sequence leaves the AT-MIO-16X circuitry in the following state:

- DMA and interrupts are disabled.
- The DMA circuitry is cleared.
- The outputs of counter/timers are in the high-impedance state.
- The analog input circuitry is initialized.
- The analog output is in immediate update mode.
- The ADC and DAC FIFOs are cleared.
- The DIO ports A and B are set for input mode.

## Initializing the Am9513A

Use the following sequence to initialize the Am9513A Counter/Timer. All writes are 16-bit operations. All values are given in hexadecimal.

After this sequence of writes, the Am9513A Counter/Timer is in the following state:

- 16-bit mode is enabled.
- The BCD scaler division is selected.
- The FOUT signal is turned off.
- All counter OUT output pins are set to the high-impedance output state.
- All counters are loaded with a nonterminal count value.

For additional details concerning the Am9513A Counter/Timer, see Appendix C, *AMD Am9513A Data Sheet*.

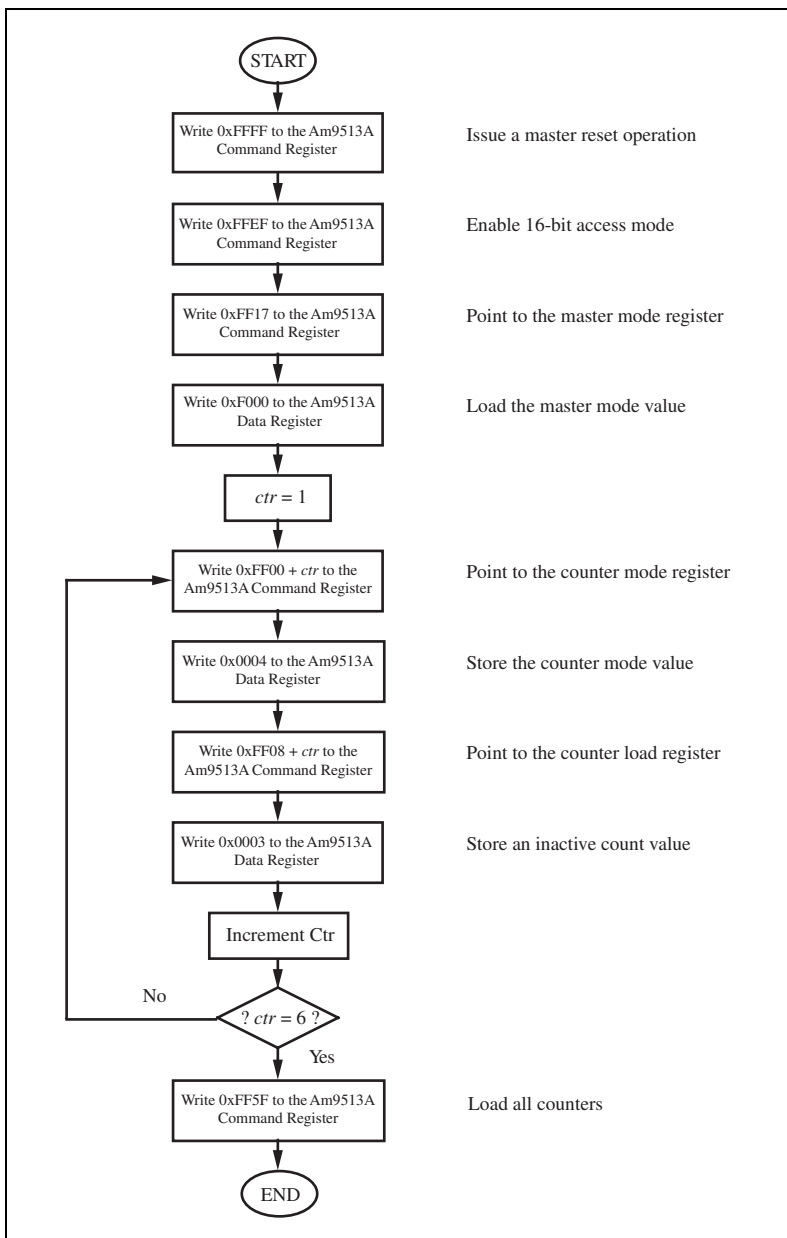

**Figure 5-1.** Initializing the Am9513A Counter/Timer

## Programming the Analog Input Circuitry

The analog input circuitry can be programmed for a number of different modes depending on the application. If single channels are to be monitored on an ad hoc basis, then the single conversion mode can be used. If a number of consecutive conversions on any one given channel are required, the single channel data acquisition mode should be used. If more than one channel needs to be monitored with multiple conversions per channel, the scanning data acquisition mode should be used. This mode scans through a programmed number of channels, each having its own gain, mode, and range setting. The channels are scanned in a round-robin fashion, separated in time by the programmed sample interval. The final mode is the interval-scanning mode. This mode should be used if more than one channel needs to be monitored, but not scanned at full speed. Interval scanning sequences through the scan list with each channel conversion separated in time by the programmed sample interval, then waits a scan interval before rescanning the list of channels. The programming of each of these acquisition modes is described in the following sections.

### Single Conversions Using the SCONVERT or EXTCONV\* Signal

Programming the analog input circuitry to obtain a single A/D conversion involves the following sequence of steps listed in Figure 5-2.

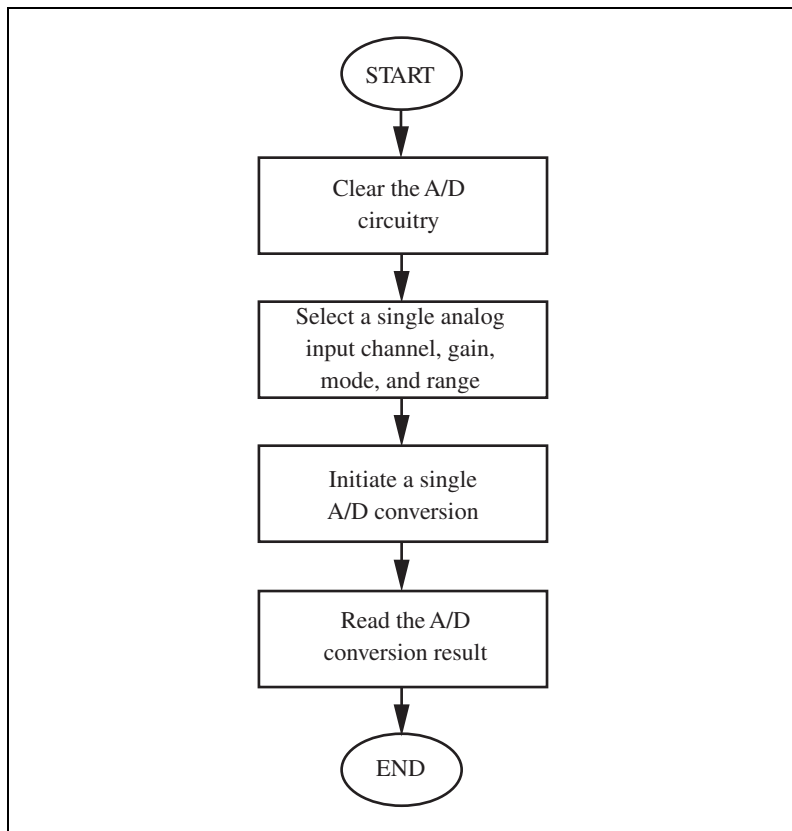

**Figure 5-2.** Single Conversion Programming

## Generating a Single Conversion

An A/D conversion can be initiated in one of two ways: a software-generated pulse or a hardware pulse. To initiate a single A/D conversion through software, access the Single Conversion Register. To initiate a single A/D conversion through hardware, apply an active low pulse to the EXTCONV\* pin on the AT-MIO-16X I/O connector. See the *Timing Connections for Data Acquisition and Analog Output* section in Chapter 2, *Configuration and Installation*, for EXTCONV\* signal specifications. Once an A/D conversion is initiated, the ADC automatically stores the result in the ADC FIFO at the end of its conversion cycle.



## Reading a Single Conversion Result

A/D conversion results are available when ADCFIFOEF\* is set in the Status Register and can be obtained by reading the ADC FIFO Register.

To read the A/D conversion result, use the following steps:

1. Read the Status Register (16-bit read).
2. If the **OVERRUN** or **OVERFLOW** bits are set, an error occurred and data was lost.
3. If the **ADCFIFOEF\*** bit is set, read the ADC FIFO Register to obtain the result.

Reading the ADC FIFO Register removes the A/D conversion result from the ADC FIFO and clears the **ADCFIFOEF\*** bit if no more values remain in the FIFO.

The **ADCFIFOEF\*** bit indicates whether one or more A/D conversion results are stored in the ADC FIFO. If the **ADCFIFOEF\*** bit is not set, the ADC FIFO is empty and reading the ADC FIFO Register returns meaningless data. Once an A/D conversion is initiated, the **ADCFIFOEF\*** bit is set approximately 10 the conversion, indicating that the data conversion result can be read from the FIFO.

An ADC FIFO overflow condition occurs if more than 512 conversions are initiated and stored in the ADC FIFO before the ADC FIFO Register is read. If this condition occurs, the **OVERFLOW** bit is set in the Status Register to alert you that one or more A/D conversion results have been lost because of FIFO overflow. Strobing the DAQ Clear Register resets this error flag.

An ADC overrun condition occurs if an attempt is made to start a new conversion while the previous conversion is being completed. If this condition occurs, the **OVERRUN** bit is set in Status Register 1 to indicate an error condition or that an invalid operation occurred. Strobing the DAQ Clear Register resets this error flag.

## Programming Single-Channel Data Acquisition Sequence

The following programming sequence for sample counts less than 65,537 leaves the data acquisition circuitry in a retriggerable state. The sample-interval and sample counters are reloaded at the end of the data acquisition to prepare for another data acquisition operation. The counters do not need reprogramming, and the next data acquisition operation starts when another trigger condition is received.

In posttrigger sequences, the sample counter starts counting after receipt of the first trigger, while in the pretrigger acquisition mode, the sample counter does not start counting until a second trigger condition occurs. The data acquisition operation is initiated by writing to the DAQ Start Register or by a falling edge on the EXTTRIG\* signal. Programming multiple A/D conversions on a single channel requires the following programming steps for posttrigger and pretrigger modes, as well as internal and external timing. The instructions in the blocks of the following flow chart are enumerated in the *Data Acquisition Programming Functions* section later in this chapter.

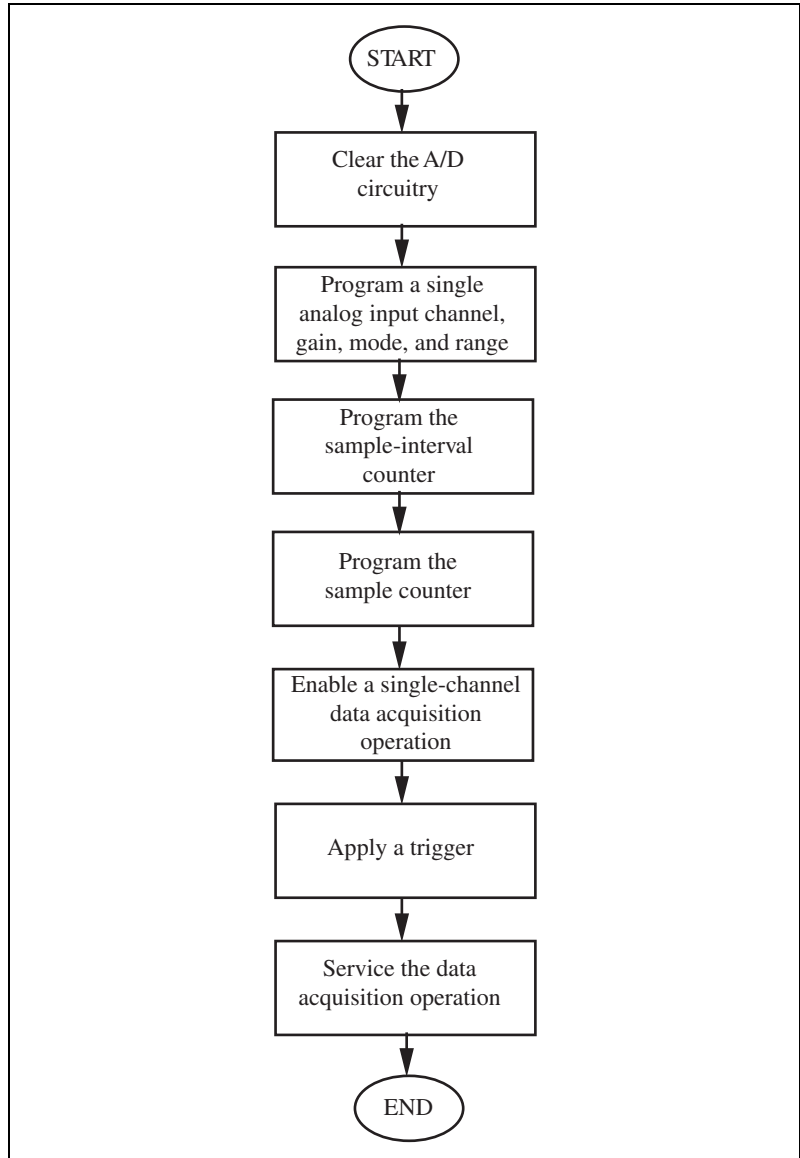

**Figure 5-3.** Single-Channel Data Acquisition Programming

## Programming Data Acquisition Sequences with Channel Scanning

The preceding data acquisition programming sequence programs the AT-MIO-16X for multiple A/D conversions on a single input channel. The AT-MIO-16X can also be programmed for scanning multiple-analog input channels with different gain, mode, and range settings during the data acquisition operation. The sequence of A/D channels and configuration settings, called the *scan sequence*, is programmed into the channel configuration memory.

There are two types of multiple A/D conversions with channel scanning: continuous channel scanning and interval-channel scanning. Continuous channel scanning cycles through the scan sequence in the channel configuration memory and repeats the scan sequence until the sample counter terminates the data acquisition. There is no delay between the cycles of the scan sequence. Continuous channel scanning can be thought of as a round-robin approach to scanning multiple channels.

Interval-channel scanning gives each scan sequence a programmed time interval called a *scan interval*. Each cycle of the scan sequence begins at the time interval determined by the scan interval. If the sample-interval counter is programmed for the minimum time required to complete an A/D conversion, interval-channel scanning can be thought of as a *pseudo-simultaneous* scanning of multiple channels; that is, all channels in the scan sequence are read as quickly as possible at the beginning of each scan interval.

### Continuous Channel Scanning Data Acquisition

Use the programming steps listed in Figure 5-4 to program continuous scanning of multiple A/D conversions for posttrigger and pretrigger modes, as well as internal and external timing. The instructions in the blocks of the following flow chart are enumerated in the *Data Acquisition Programming Functions* section later in this chapter.

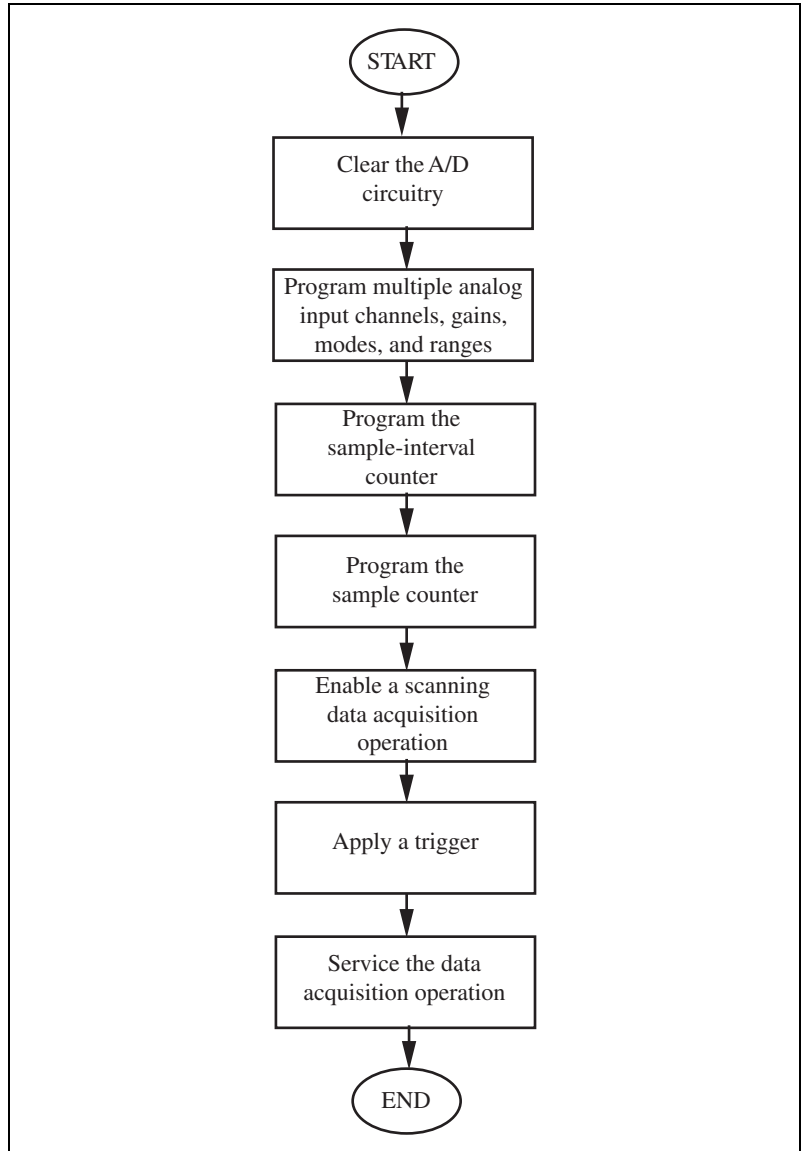
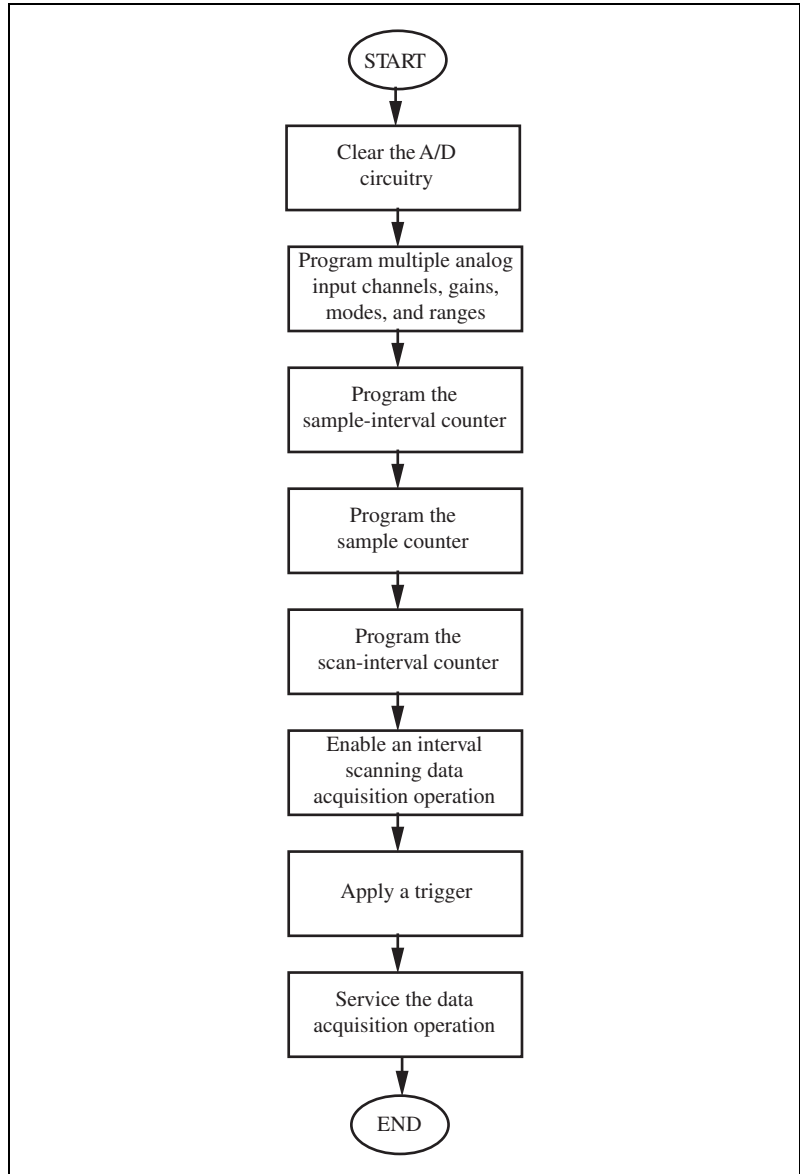

**Figure 5-4.** Scanning Data Acquisition Programming

Setting the SCANEN bit in conjunction with the DAQEN bit in Command Register 1 enables scanning during multiple A/D conversions. The SCANEN bit must be set regardless of the type of scanning used (continuous or interval); otherwise, only a single channel is scanned.

## Interval-Channel Scanning Data Acquisition

Follow the programming steps listed in Figure 5-5 to program scanned multiple A/D conversions with a scan interval (pseudo-simultaneous) for posttrigger and pretrigger modes, as well as internal and external timing. The instructions in the blocks of the following flow chart are enumerated in the *Data Acquisition Programming Functions* section later in this chapter.



**Figure 5-5.** Interval Scanning Data Acquisition Programming

Setting the SCANEN bit in conjunction with the DAQEN bit in Command Register 1 enables scanning during multiple A/D conversions. The SCANEN bit must be set regardless of the type of scanning used (continuous or interval); otherwise, only a single channel is scanned.

Setting the SCN2 bit in Command Register 1 enables the use of a scan interval during multiple A/D conversions. The scan-interval counter gives each cycle through the scan sequence a time interval. The scan-interval counter begins counting at the start of the scan sequence programmed into the channel configuration memory. When the scan sequence terminates, the next cycle through the scan sequence does not begin until the scan-interval counter has reached its terminal count. Be sure that the scan-interval counter allows enough time for all conversions in a scan sequence to occur so that conversions are not missed.

## Data Acquisition Programming Functions

---

This section provides a detailed explanation of the functions necessary to program the analog input for single and multiple channel A/D conversions.

### Clearing the Analog Input Circuitry

The analog input circuitry can be cleared by strobing the DAQ Clear Register. This operation leaves the analog input circuitry in the following state:

- Analog input error flags **OVERFLOW** and **OVERRUN** are cleared
- Pending data acquisition interrupt requests are cleared
- ADC FIFO is emptied
- **DAQCOMP** flag in the Status Register is cleared

Empty the ADC FIFO before starting any A/D conversions. This action guarantees that the A/D conversion results read from the FIFO are the results from the initiated conversions and are not left over results from previous conversions.



## Programming Single-Analog Input Channel Configurations

The analog input channel, gain, mode, and range for single conversion and single channel acquisition are selected by writing a single configuration value to the CONFIGMEM Register. This register offers a window into the channel configuration memory. The CONFIGMEMLD Register must then be strobed to load this channel configuration information. See the CONFIGMEM Register bit description earlier in this chapter for analog input channel and configuration bit patterns. Set up the bits as given in the CONFIGMEM Register bit description and write to the CONFIGMEM Register. Remember that the channel configuration memory must be first initialized with an access to the CONFIGMEMCLR Register.

Once the channel configuration memory is configured, it needs to be written to only when the analog input channel or configuration settings need to be changed.

## Programming Multiple-Analog Input Channel Configurations

During a scanning data acquisition operation, a selected number of locations in the channel configuration memory are sequenced through by the acquisition circuitry. A new channel configuration value is selected after each A/D conversion. The first conversion is performed on the first channel setting in the memory. The second conversion is performed on the second channel and gain setting, and so on. The last entry written to the channel configuration memory must have the CHAN\_LAST bit set. This bit marks the end of the scan sequence. After the last conversion is performed, the scan sequence starts over. If there are  $N$  entries in the channel configuration memory, every  $N$ th conversion in the data collected is performed on the same channel, gain, mode, and range setting.

Multiple conversions can be performed on each entry in the channel configuration memory before incrementing to the next entry in the scan sequence. If the SCANDIV bit in Command Register 1 is set, the channel configuration memory increments to the next entry when an active low pulse is detected on the Am9513A Counter/Timer OUT1 signal. If the SCANDIV bit is cleared, the channel configuration memory is incremented to the next entry after every conversion.

The channel configuration memory must be loaded with the desired scan sequence before data acquisition begins. To load the channel

configuration memory, perform the following write operations where  $N$  is the number of entries in the scan sequence:

- Strobe the CONFIGMEMCLR Register.
- For  $i = 0$  to  $N-1$ , use the following steps:
  - a. Write the desired analog channel selection and gain setting to the CONFIGMEM Register (this loads the configuration memory at location  $i$ ).
  - b. If  $i = N-1$ , also set the LASTONE bit when writing to the CONFIGMEM Register.
- Strobe the CONFIGMEMLD Register.

## Programming the Sample-Interval Counter

Counter 3 of the Am9513A Counter/Timer is used as the sample-interval counter. Counter 3 can be programmed to generate an active low pulse once every  $N$  counts.  $N$  is referred to as the sample interval, that is, the time between successive A/D conversions.  $N$  can be between 2 and 65,536. One count is equal to the period of the timebase clock used by the counter. The following internal clocks are available to the Am9513A: 5 MHz, 1 MHz, 100 kHz, 10 kHz, 1 kHz, and 100 Hz. In addition, the sample-interval timer can use signals connected to any of the Am9513A SOURCE input pins.

Using the EXTCONV\* signal from the I/O connector to control multiple A/D conversions involves disabling the sample-interval counter. This counter should be left in the high-impedance state, see the *Resetting a Single Am9513A Counter/Timer* section later in this chapter. Conversions are generated by the falling edge of the EXTCONV\* signal. Although EXTCONV\* may be pulsing, conversions do not begin until after an active low pulse on DAQ Start or the EXTTRIG\* signal. Conversions are automatically halted irrespective of the EXTCONV\* signal when the sample counter reaches zero.

To program the sample-interval counter for internal conversion signals, use the following programming sequence. All writes are 16-bit operations. All values given are hexadecimal.

1. Write FF03 to the Am9513A Command Register to select the Counter 3 Mode Register.
2. Write the mode value to the Am9513A Data Register to store the Counter 3 mode value. Am9513A counter mode information can be

found in Appendix C, *AMD Am9513A Data Sheet*. Use one of the following mode values:

8225 — Selects 5-MHz clock (from SOURCE2 pin)

8B25 — Selects 1-MHz clock

8C25 — Selects 100-kHz clock

8D25 — Selects 10-kHz clock

8E25 — Selects 1-kHz clock

8F25 — Selects 100-Hz clock

8525 — Selects signal at SOURCE5 input as clock  
(counts the rising edge of the signal, 6 MHz maximum)

3. Write FF0B to the Am9513A Command Register to select the Counter 3 Load Register.
4. Write 2 to the Am9513A Data Register to store the Counter 3 load value.
5. Write FF44 to the Am9513A Command Register to load Counter 3.
6. Write FFF3 to the Am9513A Command Register to step Counter 3 down to 1.
7. Write the desired sample interval to the Am9513A Data Register to store the Counter 3 load value:
  - If the sample interval is between 2 and FFFF (65,535 decimal), write the sample interval to the Am9513A Data Register.
  - If the sample interval is 10000 (65,536 decimal), write 0 to the Am9513A Data Register.
8. Write FF24 to the Am9513A Command Register to arm Counter 3.

After you complete this programming sequence, Counter 3 is configured to generate A/D conversion pulses as soon as application of a trigger causes it to be enabled.

## Programming the Sample Counter(s)

Counters 4 and 5 of the Am9513A Counter/Timer are used as the sample counter. The sample counter tallies the number of A/D conversions initiated by Counter 3 or EXTCONV\* and inhibits conversions when the desired sample count is reached. If the desired sample count is 65,536 or less, only Counter 4 needs to be used, making Counter 5 available for general-purpose timing applications. If the desired sample count is greater than 65,536, both Counters 4 and 5 must be used.

## Sample Counts 2 through 65,536

Use the following programming sequence to program the sample counter for sample counts up to 65,536. The minimum permitted sample count is 2. All writes are 16-bit operations. All values given are hexadecimal.

1. Write FF04 to the Am9513A Command Register to select the Counter 4 Mode Register.
2. Write 1025 to the Am9513A Data Register to store the Counter 4 mode value for posttrigger acquisition modes. Write 9025 to the Am9513A Data Register to store the Counter 4 mode value for pretrigger acquisition modes.
3. Write FF0C to the Am9513A Command Register to select the Counter 4 Load Register.
4. Write the sample count value to the Am9513A Data Register to store the Counter 4 load value:
  - If the sample count is between 2 and FFFF (65,535 decimal), write the sample count to the Am9513A Data Register.
  - If the sample count is 10000 (65,536 decimal), write 0 to the Am9513A Data Register.
5. Write FF48 to the Am9513A Command Register to load Counter 4.
6. Write FFF4 to the Am9513A Command Register to decrement Counter 4.
7. Write FF28 to the Am9513A Command Register to arm Counter 4.
8. Clear the CNT32/16\* bit in Command Register 1 to notify the hardware that only Counter 4 will be used as the sample counter.

After you complete this programming sequence, Counter 4 is configured to count A/D conversion pulses generated by Counter 3 and turns off the data acquisition operation when Counter 4 decrements to zero.

## Sample Counts Greater than 65,536

To program the sample counter for sample counts greater than 65,536, use the following programming sequence to concatenate Counter 4 to Counter 5. The lower 16 bits of the sample count are stored in Counter 4, and the upper 16 bits of the sample count are stored in Counter 5. All writes are 16-bit operations. All values given are hexadecimal.

1. Write FF04 to the Am9513A Command Register to select the Counter 4 Mode Register.
2. Write 1025 to the Am9513A Data Register to store the Counter 4 mode value for posttrigger acquisition modes. Write 9025 to the Am9513A Data Register to store the Counter 4 mode value for pretrigger acquisition modes.
3. Write FF0C to the Am9513A Command Register to select the Counter 4 Load Register.
4. Write the 16 LSBs of the sample count value minus 1 to the Am9513A Data Register to store the Counter 4 load value.
  - If the 16 LSBs are all 0, write FFFF.
5. Write FF48 to the Am9513A Command Register to load Counter 4.
6. Write 0 to the Am9513A Data Register to store 0 into the Load Register for Counter 4 reloading.
7. Write FF28 to the Am9513A Command Register to arm Counter 4.
8. Write FF05 to the Am9513A Command Register to select the Counter 5 Mode Register.
9. Write 25 to the Am9513A Data Register to store the Counter 5 mode value.
10. Write FF0D to the Am9513A Command Register to select the Counter 5 Load Register.
11. Take the 16 MSBs of the sample count and complete the following steps:
  - If the 16 LSBs of the sample count are all 0 or all 0 except for a 1 in the LSB, write the 16 MSBs to the Am9513A Data Register to store the Counter 5 load value.
  - Otherwise, add 1 to the 16 MSBs of the sample count and write that value to the Am9513A Data Register to store the Counter 5 load value.
12. Write FF70 to the Am9513A Command Register to load and arm Counter 5.
13. Set the CNT32/16\* bit in Command Register 1 to notify the hardware that both Counters 4 and 5 will be used as the sample counter.

After you complete this programming sequence, Counter 4 is configured to count A/D conversion pulses generated by Counter 3, and Counter 5 decrements every time Counter 4 reaches zero. The data

acquisition operation is terminated when Counter 4 and Counter 5 reach zero.

## Programming the Scan-Interval Counter

Counter 2 of the Am9513A Counter/Timer is used as the scan-interval counter. Counter 2 can be programmed to generate a pulse once every  $N$  counts.  $N$  is referred to as the scan interval, which is the time between successive scan sequences programmed into the mux-channel gain memory.  $N$  can be between 2 and 65,536. One count is equal to the period of the timebase clock used by the counter. The following clocks are available internal to the Am9513A: 5 MHz, 1 MHz, 100 kHz, 10 kHz, 1 kHz, and 100 Hz. In addition, the scan-interval timer can use signals connected to any of the Am9513A SOURCE input pins.

To program the scan-interval counter, use the following programming sequence. All writes are 16-bit operations. All values given are hexadecimal.

1. Write FF02 to the Am9513A Command Register to select the Counter 2 Mode Register.
2. Write the mode value to the Am9513A Data Register to store the Counter 2 mode value. Use one of the following mode values:
  - 8225 — Selects 5-MHz clock (Counter 2 Source signal)
  - 8B25 — Selects 1-MHz clock
  - 8C25 — Selects 100-kHz clock
  - 8D25 — Selects 10-kHz clock
  - 8E25 — Selects 1-kHz clock
  - 8F25 — Selects 100-Hz clock
  - 8525 — Selects signal at SOURCE5 input as clock  
(counts the rising edge of the signal, 6 MHz maximum)
3. Write FF0A to the Am9513A Command Register to select the Counter 2 Load Register.
4. Write 2 to the Am9513A Data Register to store the Counter 2 load value.
5. Write FF42 to the Am9513A Command Register to load Counter 2.
6. Write FFF2 to the Am9513A Command Register to step Counter 2 down to 1.

7. Entries stored in the mux-channel gain memory should be scanned once during a scan interval. The following condition must be satisfied:

scan interval  $\geq$  sample interval \*  $x$ , where  $x$  is the number of entries in the scan sequence.

Write the desired scan interval to the Am9513A Data Register to store the Counter 2 load value:

- If the scan interval is between 2 and FFFF (65,535 decimal), write the scan interval to the Am9513A Data Register.
- If the scan interval is 10000 (65,536 decimal), write 0 to the Am9513A Data Register.

8. Write FF22 to the Am9513A Command Register to arm Counter 2.

After you complete this programming sequence, Counter 2 is configured to assign a time interval to scan sequences once the trigger to enable A/D conversions is detected.

## Applying a Trigger

Once a data acquisition operation has been configured and programmed, the acquisition sequence is initiated when a trigger is received. A trigger can be initiated through software or hardware.

To initiate the data acquisition operation through software, strobe the Start DAQ Register. Make sure EXTTRIG\* is not pulled low at the I/O connector or the RTSI switch.

To initiate the data acquisition operation through hardware, apply an active low pulse to the EXTTRIG\* pin on the AT-MIO-16X I/O connector. See the *Timing Connections for Data Acquisition and Analog Output* section in Chapter 2, *Configuration and Installation*, for EXTTRIG\* signal specifications.

Once the trigger is applied, Counter 3 generates pulses initiating A/D conversions once every sample interval until the sample counter reaches zero. In the pretrigger mode, these conversions are not counted by the sample counter. Counting begins only after the application of a second hardware or software trigger condition and continues until the sample counter reaches zero. A/D conversion data stored before receipt of the EXTTRIG\* or DAQ Start signal are pretrigger samples.

## Servicing the Data Acquisition Operation

Once the data acquisition operation is initiated with the application of a trigger, the operation must be serviced by reading the ADC FIFO. The ADC FIFO can be serviced in two different ways. One method is to monitor the ADCFIFOEF\* to read the A/D conversion result every time one becomes available. Another method is to monitor the ADCFIFOHF\* flag and read in values only when the ADC FIFO is at least half-full. If the FIFO is half-full, a block of 256 values can be consecutively read in. The advantage of this second method is that Status Register 1 needs to be read only once for every 256 values, while the first method requires one status register to be read per ADC FIFO read.

To service the data acquisition operation, perform the following sequence until the data acquisition has completed:

1. Read Status Register 1 (16-bit read).
2. If the **OVERRUN** or **OVERFLOW** bits are set, the data acquisition sequence has been halted because one of these error conditions has occurred. Clear the A/D circuitry by writing to DAQ Clear Register and determine the cause of the error. **OVERRUN** and **OVERFLOW** are explained in the *Status Register 1* section in Chapter 4, *Register Map and Descriptions*.
3. If the **ADCFIFOEF\*** bit is set (or the **ADCFIFOHF\*** bit), read the ADC FIFO Register to obtain the result(s).

Interrupts or DMA can also be used to service the data acquisition operation. These topics are discussed later in this chapter.

## Resetting the Hardware after a Data Acquisition Operation

After a data acquisition operation terminates, if no errors occurred and the sample count was less than or equal to 10000 hex, the AT-MIO-16X is left in the same state as it was at the beginning of the data acquisition operation. The counters do not need to be reprogrammed; another data acquisition operation begins when a trigger is received. If the next data acquisition operation requires the counters to be programmed differently, the Am9513A counters that were used must be disarmed and reset.



## Resetting a Single Am9513A Counter/Timer

To reset a particular counter in the Am9513A, use the following programming sequence. All writes are 16-bit operations. All values given are hexadecimal. The equation  $\{2^{(ctr - 1)}\}$  means  $\{2^{\text{“raised to”}}(ctr - 1)\}$ . If ctr is equal to 4, then  $2^{(ctr - 1)}$  results in  $2^3$ , or  $2 * 2 * 2$ , or 8. This result can also be obtained by shifting 1 left three times.

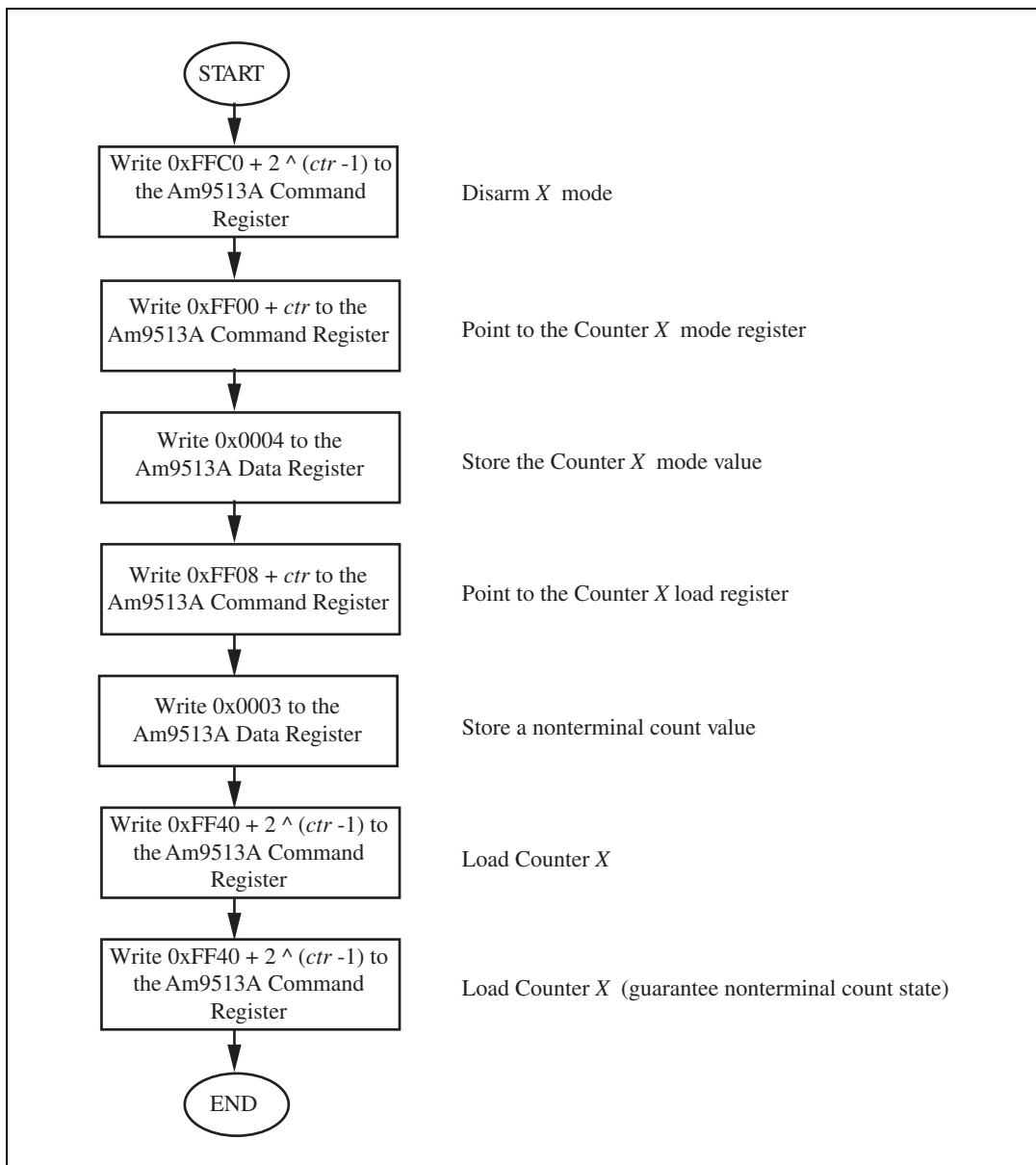

**Figure 5-6.** Resetting an Am9513A Counter/Timer

## Programming the Analog Output Circuitry

The voltages at the analog output circuitry output pins (pins DAC0 OUT and DAC1 OUT on the AT-MIO-16X I/O connector) are controlled by loading the DAC in the analog output channel with a 16-bit digital code. The DAC is loaded by writing the digital code to the DAC0 and DAC1 Registers, and then the converted output is available at the I/O connector. Writing to the DAC0 Register controls the voltage at the DAC0 OUT pin, while writing to the DAC1 Register controls the voltage at the DAC1 OUT pin. The analog output on pins DAC0 OUT and DAC1 OUT can be updated in one of three ways: immediately when DAC0 or DAC1 is written to, when an active low pulse is detected on the TMRTRIG\* signal, or when the DAC Update Register is strobed. The TMRTRIG\* signal is either the EXTTMRTRIG\* signal from the I/O connector or an internal signal from the output of Counters 1, 2, 3, or 5, depending on the state of the A4RCV bit in Command Register 2. The update method is selected through mode bits in the Command Register 4.

In the waveform mode where a timer trigger generates an update for the DACs and a request for new data, the DAC FIFO is used to buffer the incoming data to both of the DAC channels. Because this FIFO is 2,048 values deep, the last value buffered by the DAC FIFO could lag the output of the DAC channel by up to 2,048 times the update interval. Requests can be programmed to be generated whenever the DAC FIFO is not full or only when the FIFO is less than half-full. If the half-full method is used, 1,024 values can be written at once without reading the DAC FIFO flags after each subsequent transfer to keep from overflowing the FIFO. This mode results in a significant performance increase in polled I/O or interrupt servicing of the DACs.

The waveform circuitry is configured through mode bits in Command Register 4 to perform one or two DAC writes per update pulse. If two DAC channels are being used and single update mode (DACMODEB3 is clear) is enabled, only one value is read from the DAC FIFO and written to the appropriate DAC channel per update pulse. The result is that the channel updates are out of phase with respect to each other. If the dual update mode is used (DACMODEB3 is set), the circuitry will read up to two values from the DAC FIFO and write them to the appropriate DAC channels. If the dual update mode is enabled, and only one DAC is used, then the circuitry will perform only one FIFO read and DAC write per update pulse. Notice that if two channels are used, the DAC0 value must be written to the DAC FIFO before the DAC1 value.

## Cyclic Waveform Generation

The simplest mode of waveform generation is the cyclic mode in which an internal or external timing signal is used to update the DACs. In this case, DAC updating begins when the timing signal starts, and ends when the timing signal is removed. A special case of this mode occurs when the buffer fits entirely within the DAC FIFO where it is cycled through. If this is true, and the CYCLICSTOP bit in Command Register 4 is set, DAC updating stops at the next end of buffer. This provides a known final value for the DACs.

To update the analog output DACs in cyclic waveform generation mode, the following sequence of programming steps in Figure 5-7 must be followed. The instructions in the blocks of the following flow chart are enumerated in the *Waveform Generation Programming Functions* section later in this chapter.

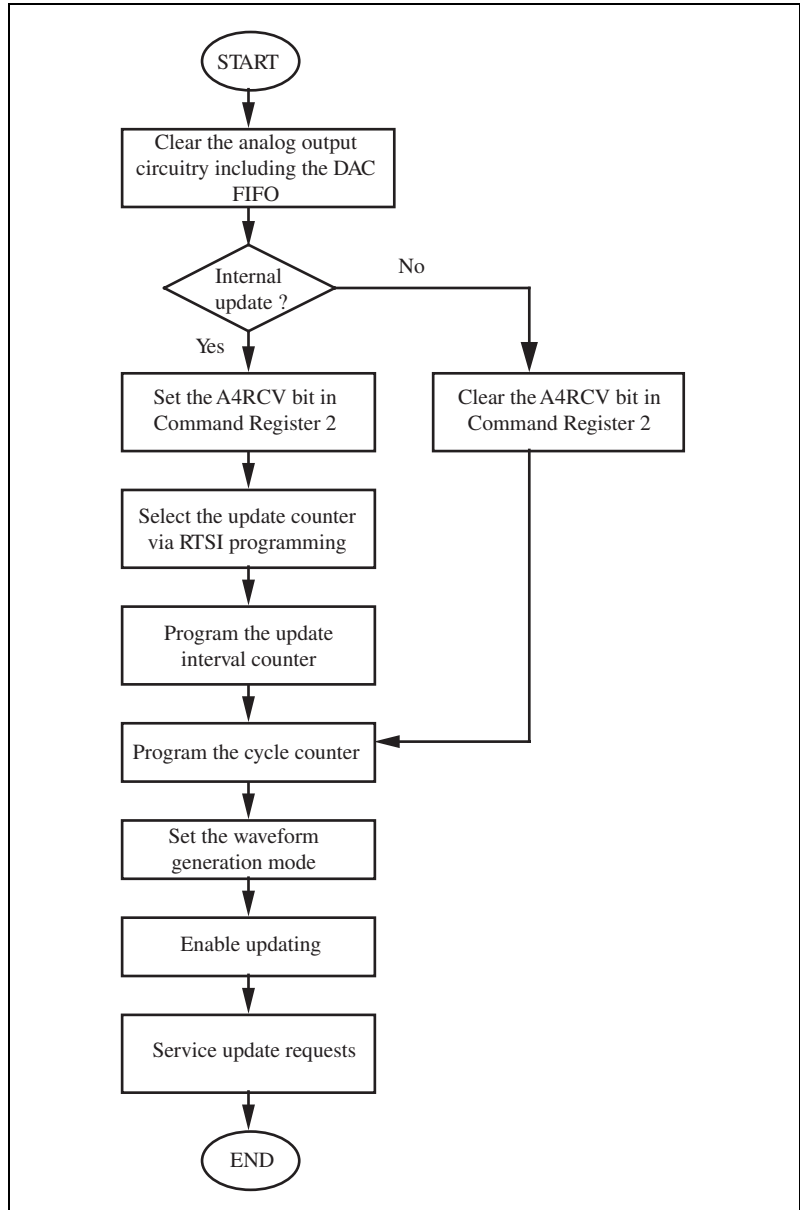
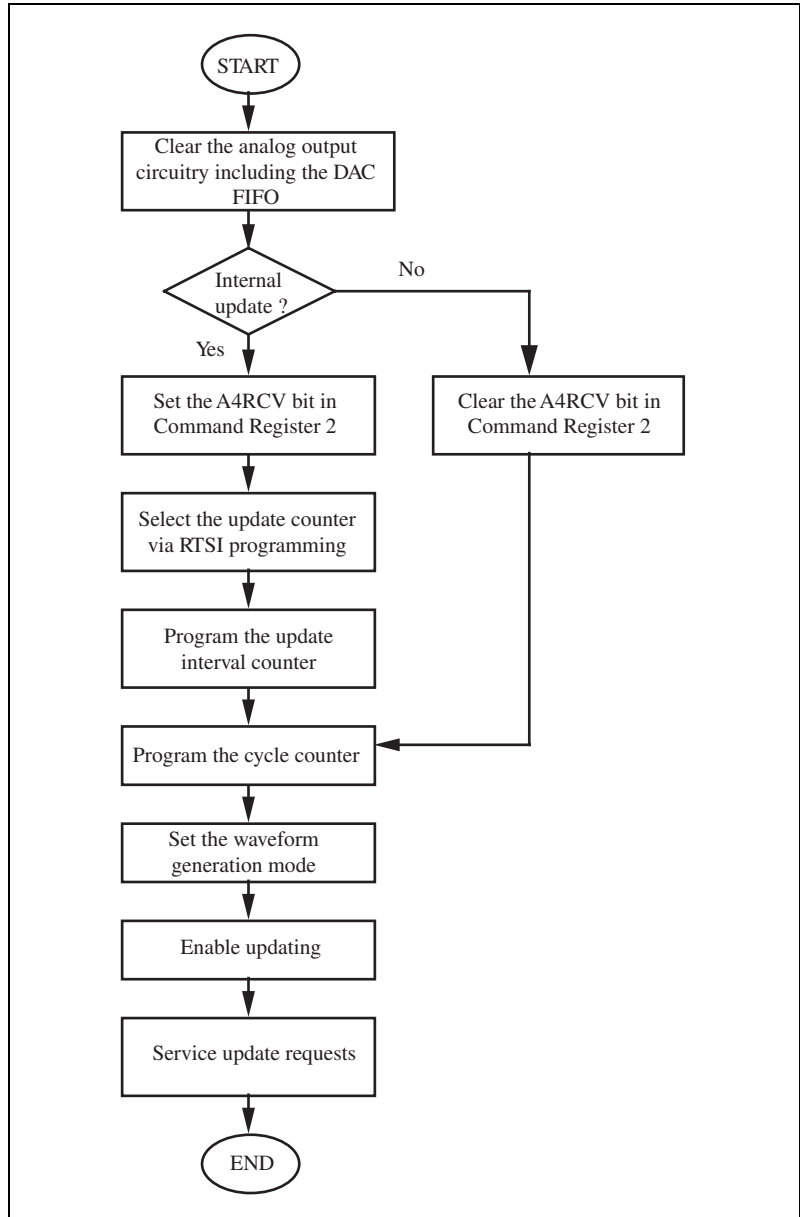

**Figure 5-7.** Cyclic Waveform Programming

## Programmed Cycle Waveform Generation

A superset of the waveform functionality exists if DAC data buffer is less than or equal to 2,048 for one channel, or less than or equal 1,024 per DAC for two channels. In these cases, the entire buffer resides wholly within the DAC FIFO where the waveform circuitry cycles through the buffer when the end is reached. This removes a large burden on the PC bus for continually updating data in the DAC FIFO. Also due to the smaller buffer size, the hardware has more control over the updating and cycling through of the buffer. This enables the waveform circuitry to perform cycle counting, programmed cycle generation, and pulsed cyclic waveform generation.

To update the analog output DACs in programmed cycle waveform generation mode, complete the sequence of programming steps in Figure 5-8. The instructions in the blocks of the following flow chart are enumerated in the *Waveform Generation Programming Functions* section later in this chapter.



**Figure 5-8.** Programmed Cycle Waveform Programming

One disadvantage of the programmed cycle waveform generation is that it uses yet another counter to perform the cycle counting. For this mode, the SRC3SEL bit in Command Register 4 must be set so that the programmed counter can count the buffer retransmit signals from the source line of Counter 3. Counter 1, 2, or 5 can be used to count buffer cycles in this mode. If Counter 5 is being used for the update signal, then only Counters 1 and 2 are available for cycle counting. Once the cycle counter reaches the end of its count, DAC updating is halted irrespective of the update signal.

## Pulsed Cyclic Waveform Generation

An extension of the programmed cycle mode is the pulsed cyclic waveform generation mode in which a programmed number of cycles is generated between a programmed cycle interval. The instructions in the blocks of the following flow chart are enumerated in the *Waveform Generation Programming Functions* section later in this chapter.



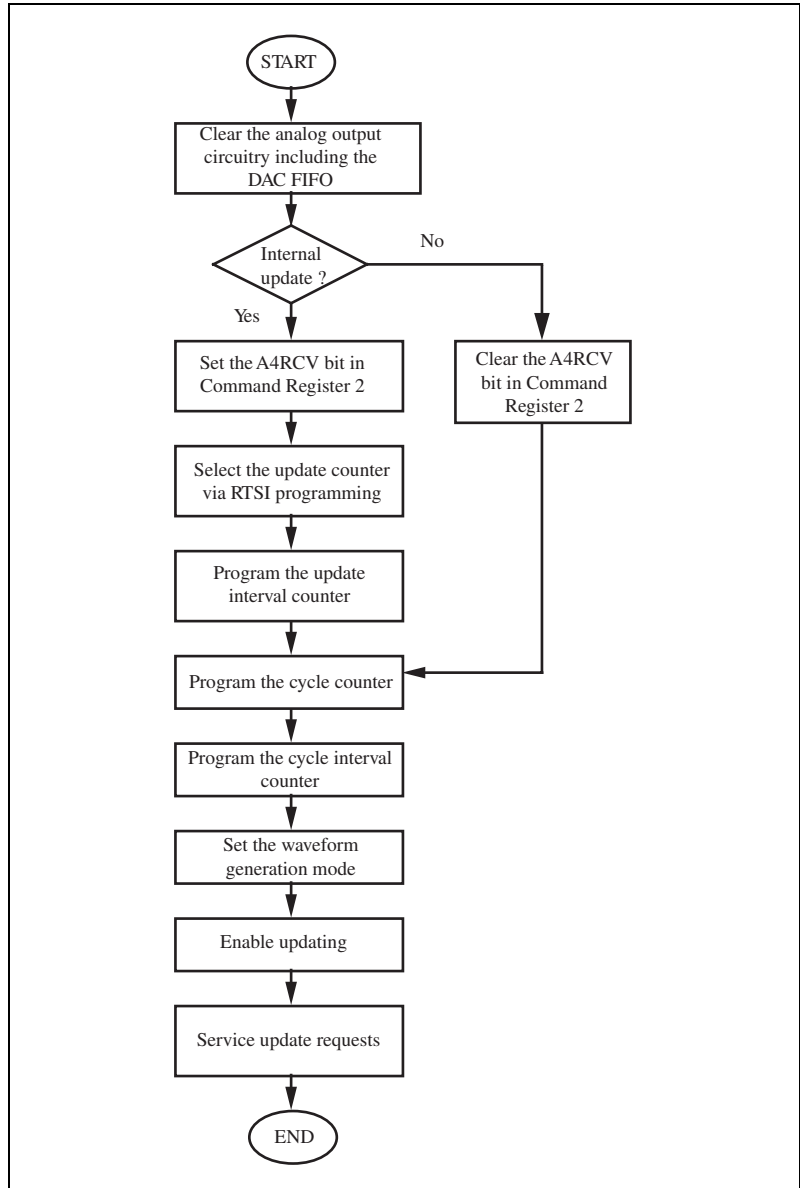

**Figure 5-9.** Pulsed Cyclic Waveform Programming

In this mode, Counter 1 counts the programmed number of cycles before terminating the sequence. Counter 2 then begins counting the time between cycles, the cycle interval, then restarts the sequence. This

sequence of events continues ad infinitum and does not stop until the update signal is removed or the DAC circuitry is cleared.

This sequence requires that the GATE2SEL signal in addition to the SRC3SEL signal be set in Command Register 4. This allows Counter 1 to count the buffer retransmit signals from the source line of Counter 3 while Counter 2 is gated by the signal at its own gate pin.

## Waveform Generation Programming Functions

This section provides a detailed explanation of the programming functions necessary to generate synchronously timed analog output waveforms.

### Clearing the Analog Output Circuitry

This involves clearing the TMRREQ, DACCOMP, and DMATCA or DMATCB bits in the Status Register. To do this, access the TMRREQ Clear, DAC Clear, and if necessary, the DMATCA or DMATCB Clear registers.

### Selecting the Internal Update Counter

Select the desired signal at the RTSI switch to be used for updating the DACs. OUT1, OUT2, OUT3 (available as EXTCONV\*), and OUT5 are available for updating. To route these update signals, the A side pin of the RTSI switch must be internally routed to the B side, or trigger side. Select a trigger line that is not being used. The signal must be routed from the selected B side trigger line to the A4 pin on the RTSI switch. All of this is done in one programming sequence by shifting a 56-bit value to the RTSI switch. See the *RTSI Bus Trigger Line Programming Considerations* section later in this chapter.

Notice that if OUT5 is to be used for updating, it does not need to be routed across the RTSI switch. In this case only is it sufficient to enable A4DRV to drive pin A4 of the RTSI switch with OUT5.

## Programming the Update-Interval Counter

Select the appropriate counter (1, 2, 3, or 5) from the Am9513A Counter/Timer to be used for updating the DACs. Active low pulsing and no gating should be part of the mode programmed. To program the update-interval counter, complete the following programming

sequence. All writes are 16-bit operations. All values given are hexadecimal.

1. Write  $\text{FF00} + n$  to the Am9513A Command Register to select the Counter  $n$  Mode Register.
2. Write the mode value to the Am9513A Data Register to store the Counter  $n$  mode value. Am9513A counter mode information can be found in Appendix C, *AMD Am9513A Data Sheet*. Use one of the following mode values:
  - 0225 — Selects 5-MHz clock (from SOURCE2 pin)
  - 0B25 — Selects 1-MHz clock
  - 0C25 — Selects 100-kHz clock
  - 0D25 — Selects 10-kHz clock
  - 0E25 — Selects 1-kHz clock
  - 0F25 — Selects 100-Hz clock
  - 0525 — Selects signal at SOURCE5 input as clock  
(counts the rising edge of the signal, 6 MHz maximum)
3. Write  $(\text{FF08} + n)$  to the Am9513A Command Register to select the Counter  $n$  Load Register.
4. Write the desired update interval to the Am9513A Data Register to store the counter  $n$  load value.
5. Write the following value to the Am9513A Command Register to load counter  $n$ .
  - FF41 — Load Counter 1
  - FF42 — Load Counter 2
  - FF50 — Load Counter 5
6. Write  $(\text{FFF0} + n)$  to the Am9513A Command Register to decrement Counter  $n$ .
7. Write the following value to the Am9513A Command Register to arm Counter  $n$ .
  - FF21 — Arm Counter 1
  - FF22 — Arm Counter 2
  - FF30 — Arm Counter 5

After you complete this programming sequence, Counter  $n$  is configured to generate active-low pulses as soon as the load/arm counter command is written.

## Programming the Waveform Cycle Counter

Select the appropriate counter (1, 2, or 5) from the Am9513A Counter/Timer to be used for counting DAC buffer cycles. To program the cycle counter, complete the following programming sequence. All writes are 16-bit operations. All values given are hexadecimal.

1. Write  $FF00 + n$  to the Am9513A Command Register to select the Counter  $n$  Mode Register.
2. Write 0325 to the Am9513A Data Register to store the Counter  $n$  mode value. Am9513A counter mode information can be found in Appendix C, *AMD Am9513A Data Sheet*.
3. Write  $(FF08 + n)$  to the Am9513A Command Register to select the Counter  $n$  Load Register.
4. Write the desired cycle count to the Am9513A Data Register to store the Counter  $n$  load value.
5. Write the following value to the Am9513A Command Register to load Counter  $n$ .
  - FF41 — Load Counter 1
  - FF42 — Load Counter 2
  - FF50 — Load Counter 5
6. Write  $(FFF0 + n)$  to the Am9513A Command Register to decrement Counter  $n$ .
7. Write the following value to the Am9513A Command Register to arm Counter  $n$ .
  - FF21 — Arm Counter 1
  - FF22 — Arm Counter 2
  - FF30 — Arm Counter 5

After you complete this programming sequence, Counter  $n$  is configured to count the DAC buffer retransmit signal from SOURCE3 as soon as the load/arm counter command is written.

## Programming the Waveform Cycle Interval Counter

To program the cycle-interval Counter for a pulsed cyclic waveform generation mode, use the following programming sequence. All writes are 16-bit operations. All values given are hexadecimal.

1. Write FF02 to the Am9513A Command Register to select the Counter 2 Mode Register.

2. Write the mode value to the Am9513A Data Register to store the Counter 2 mode value. Am9513A counter mode information can be found in Appendix C, *AMD Am9513A Data Sheet*.
  - C225 — Selects 5-MHz clock (from SOURCE2 pin)
  - CB25 — Selects 1-MHz clock
  - CC25 — Selects 100-kHz clock
  - CD25 — Selects 10-kHz clock
  - CE25 — Selects 1-kHz clock
  - CF25 — Selects 100-Hz clock
  - C525 — Selects signal at SOURCE5 input as clock  
(counts the rising edge of the signal, 6 MHz maximum)
3. Write FF0A to the Am9513A Command Register to select the Counter 2 Load Register.
4. Write the desired cycle interval plus one to the Am9513A Data Register to store the Counter 2 load value.
5. Write FF42 to the Am9513A Command Register to load Counter 2.
6. Write FFF2 to the Am9513A Command Register to decrement Counter 2.
7. Write FF22 to the Am9513A Command Register to arm Counter 2.

After you complete this programming sequence, Counter 2 is configured to count the desired interval after each rising edge on GATE2 is encountered. The terminal count active low edge will restart the waveform generation process.

## Servicing Update Requests

Updating the DACs using a timer signal can be handled using either polled I/O, interrupts or DMA requests. Upon the application of a falling edge signal to the TMRTRIG\* signal, both DACs are updated and TMRREQ in Status Register 1 is set and if DMA or interrupts are enabled, a request is generated. TMRTRIG\* can be connected to selected internal signals on the RTSI bus with A4RCV set or the external signal EXTTMRTRIG\* with A4RCV cleared. In the polled I/O mode, the TMRREQ signal must be monitored in the Status Register to determine when the previous value has been updated to the DAC and a new value is required. The most desirable solution involves the use of interrupts because the PC is not dedicated to monitoring the Status Register. If interrupts are enabled, an interrupt occurs when TMRREQ is set. In interrupt mode, TMRREQ must be cleared using the TMRREQ

Clear Register before exiting the interrupt routine. This clears the interrupt request. The best method of servicing update requests is with DMA since this is done in parallel with the PC CPU. If DMA is enabled, DMA requests are generated when TMRREQ is set. When the DMA controller acknowledges the request, TMRREQ is automatically cleared.

An error is indicated in timer waveform generation when the DACCOMP bit in Status Register 1 is set prematurely. If DACFIFOEF\* is clear when another update occurs, then an error has occurred. This error indicates an underrun condition, where rates are above the maximum rate of the DMA controller or interrupt handling capabilities. The error condition is cleared by writing to the TMRREQ Clear Register or the DAC Clear Register.

## Programming the Digital I/O Circuitry

---

The digital input circuitry is controlled and monitored using the Digital Input Register, the Digital Output Register, and the two bits DIOPAEN and DIOPBEN in Command Register 2. See the register bit descriptions earlier in this chapter for more information.

To enable digital output port A, set the DIOPAEN bit in Command Register 2. To enable digital output port B, set the DIOPBEN bit in Command Register 2. When a digital output port is enabled, the contents of the Digital Output Register are driven onto the digital lines corresponding to that port. The digital output for both ports A and B are updated by writing the desired pattern to the Digital Output Register.

In order for an external device to drive the digital I/O lines, the input ports must be enabled. Clear the DIOPAEN bit in Command Register 2 if an external device is driving digital I/O lines ADIO<3..0>. Clear the DIOPBEN bit in Command Register 2 if an external device is driving digital I/O lines BDIO<3..0>. The Digital Input Register can then be read to monitor the state of the digital I/O lines as driven by the external device.

The logic state of all eight digital I/O lines can be read from the Digital Input Register. If the digital output ports are enabled, the Digital Input Register serves as a read-back register; that is, you can determine how the AT-MIO-16X is driving the digital I/O lines by reading the Digital Input Register.

If any digital I/O line is not driven, it floats to an indeterminate value. If more than one device is driving any digital I/O line, the voltage at that line may also be indeterminate. In these cases, the digital line has no meaningful logic value, and reading the Digital Input Register may return either 1 or 0 for the state of the digital line.

## Programming the Am9513A Counter/Timer

---

Counters 1, 2, and 5 of the Am9513A Counter/Timer are available for general-purpose timing applications. The programmable frequency output pin FOUT is also available as a timing signal source. These applications and a general description of the Am9513A Counter/Timer are included in the *Timing Connections for Data Acquisition and Analog Output* section in Chapter 2, *Configuration and Installation*. The *Timing I/O Circuitry* section in Chapter 3, *Theory of Operation*, explains how the Am9513A is used on the AT-MIO-16X board.

Initialization of the Am9513A as required by the AT-MIO-16X and specific programming requirements for the sample-interval and sample counters are given earlier in this chapter. For general programming details for Counters 1, 2 and 5, and the programmable frequency output, refer to Appendix C, *AMD Am9513A Data Sheet*.

In programming the Master Mode Register, keep the following considerations in mind:

- The Am9513A must be used in 16-bit bus mode.
- The scaler control should be set to BCD division for correct operation of the clocks as shown in Figure 5-1.

## RTSI Bus Trigger Line Programming Considerations

---

The RTSI switch connects signals on the AT-MIO-16X to the seven RTSI bus trigger lines. The RTSI switch has seven pins labeled A<6..0> connected to AT-MIO-16X signals and seven pins labeled B<6..0> connected to the seven RTSI bus trigger lines. Table 5-2 shows the signals connected to each pin.

**Table 5-2.** RTSI Switch Signal Connections

RTSI Switch Pin	Signal Name	Signal Direction
A Side		
A0	EXTCONV*	Bidirectional
A1	FOUT	Output
A2	OUT2	Output
A2	GATE1	Input
A3	SOURCE5	Bidirectional
A4	OUT5	Output
A4	TMRTRIG*	Input
A5	OUT1	Bidirectional
A6	EXTTRIG*	Bidirectional
B Side		
B0	TRIGGER0	Bidirectional
B1	TRIGGER1	Bidirectional
B2	TRIGGER2	Bidirectional
B3	TRIGGER3	Bidirectional
B4	TRIGGER4	Bidirectional
B5	TRIGGER5	Bidirectional
B6	TRIGGER6	Bidirectional

Figure 3-19 in Chapter 3, *Theory of Operation*, diagrams the AT-MIO-16X RTSI switch connections.

## RTSI Switch Signal Connection Considerations

The AT-MIO-16X board has a total of nine signals connected to the seven A-side pins of the RTSI crossbar switch. These same signals also appear at the AT-MIO-16X I/O connector. As shown in Table 5-2, two AT-MIO-16X signals are connected to pin A2, and two signals are connected to pin A4. The routing of these signals is further controlled by the bits A4DRV, A4RCV, A2DRV, and A2RCV in Command Register 2.

- To drive the RTSI switch pin A2 with the signal OUT2, set the A2DRV bit in Command Register 2. Otherwise, clear the A2DRV bit.
- To drive the signal GATE1 from pin A2 of the RTSI switch, set the A2RCV bit in Command Register 2. Otherwise, clear the A2RCV bit.





**Note:** *If both the A2DRV and A2RCV bits are set, the GATE1 signal is driven by the signal OUT2. This arrangement is probably not desirable.*

- To drive the RTSI switch pin A4 with the signal OUT5, set the A4DRV bit in Command Register 2. Otherwise, clear the A4DRV bit.
- To drive the signal TMRTRIG\* from pin A4 of the RTSI switch, set the A4RCV bit in Command Register 2. Otherwise, clear the A4RCV bit.



**Note:** *If both the A4DRV and A4RCV bits are set, the TMRTRIG\* signal is driven by the signal OUT5.*

## Programming the RTSI Switch

---

The RTSI switch is a 7×7 crossbar switch which can be programmed to connect any of the signals on the A side to any of the signals on the B side and vice versa. To do this, a 56-bit pattern is shifted into the RTSI switch by writing one bit at a time to the RTSI Switch Shift Register and then writing to the RTSI Switch Strobe Register to load the pattern into the RTSI switch.

The 56-bit pattern is made up of two 28-bit patterns, one for side A and one for side B of the RTSI switch. The low-order 28 bits select the signal sources for the B-side pins. The high-order 28 bits select the signal sources for the A-side pins. Each of the 28-bit patterns are made up of seven 4-bit fields, one for each pin. The 4-bit field selects the signal source and the output enable for the pin. Figure 5-10 shows the bit map of the RTSI switch 56-bit pattern.

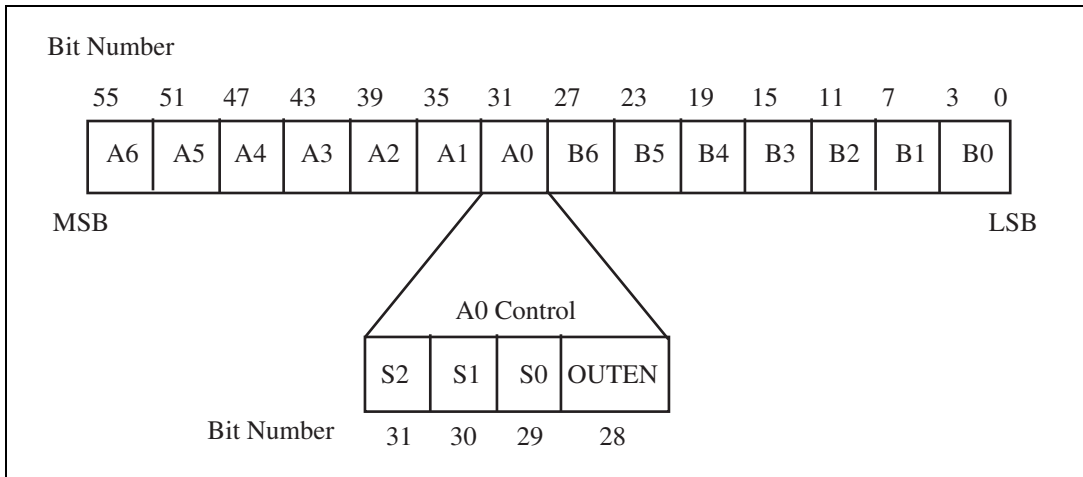

**Figure 5-10.** RTSI Switch Control Pattern

In Figure 5-10, the fields labeled A6 through A0 and B6 through B0 are the 4-bit control fields for each RTSI switch pin of the same name. The 4-bit control field for pin A0 is shown in Figure 5-10.

The bits labeled S2 through S0 are the signal source selection bits for the pin. One of seven source signals can be selected. Pins A6 through A0 can select any of the pins B6 through B0 as signal sources. Pins B6 through B0 select any of the pins A6 through A0 as signal sources. For example, the pattern 011 for S2 through S0 in the A0 control field selects the signal connected to pin B3 as the signal source for pin A0.

The bit labeled OUTEN is the output enable bit for that pin. If the OUTEN bit is set, the pin is driven by the selected source signal (the pin acts as an output pin). If the OUTEN bit is cleared, the pin is not driven regardless of the source signal selected; instead, the pin can be used as an input pin.

If the preceding A0 control field contains the pattern 0111, the signal connected to pin B3 (Trigger Line 3) appears at pin A0. On the AT-MIO-16X board, this arrangement allows the EXTCONV\* signal to be driven by Trigger Line 3. Conversely, if the B4 control field contains the pattern 1011, the signal connected to pin A5 appears at pin B4. This arrangement allows Trigger Line 4 to be driven by the AT-MIO-16X OUT1 signal. In this way, boards connected via the RTSI bus can send signals to each other over the RTSI bus trigger lines.

To program the RTSI switch, complete these steps:

1. Calculate the 56-bit pattern based on the desired signal routing.
  - a. Clear the OUTEN bit for all input pins and for all unused pins.
  - b. Select the signal source pin for all output pins by setting bits S2 through S0 to the source pin number.
  - c. Set the OUTEN bit for all output pins.
2. For  $i = 0$  to 55, follow these steps:
  - a. Copy bit  $i$  of the 56-bit pattern to bit 0 of an 8-bit temporary variable.
  - b. Write the temporary variable to the RTSI Switch Shift Register (8-bit write).
3. Write 0 to the RTSI Switch Strobe Register (8-bit write). This operation loads the 56-bit pattern into the RTSI switch. At this point, the new signal routing goes into effect.

Step 2 can be completed by simply writing the low-order 8 bits of the 56-bit pattern to the RTSI Switch Shift Register, then shifting the 56-bit pattern right once, and repeating this two-step operation a total of 56 times. Only bit 0 of the word written to the RTSI Switch Shift Register is used. The higher-order bits are ignored.

## Programming DMA Operations

The AT-MIO-16X can be programmed so that the ADCFIFOEF\* generates DMA requests every time one or more A/D conversion values are stored in the ADC FIFO, when the ADCFIFOHF\* is low and the FIFO is half-full, and when the DACFIFO requires at least one data value (DACFIFOFF\* is set), and when the DACFIFO is less than half full (DACFIFOHF\* is set). There are two DMA modes: single-channel transfer and dual-channel transfer. Single-channel DMA uses only channel A DMA signals, while dual-channel DMA uses signals for both Channel A and Channel B. The DMA channels are selected through Command Register 2. To program the DMA operation, perform the following steps after the circuitry on the AT-MIO-16X is set up:

1. Set the appropriate mode bits in Command Register 3 to enable DMA request generation.
2. Access the DMATCA and DMATCB Clear Registers, the TMRREQ Clear Register, the DAC Clear Register, and the DAQ Clear Register.

3. Program the DMA controller to service DMA requests from the AT-MIO-16X board. Refer to the *IBM Personal Computer AT Technical Reference* manual for more information on DMA controller programming.
4. If a DMA terminal count is received after the DMA service, write 0 to either the appropriate DMATC Clear Register to clear the DMATCA or DMATCB bits in Status Register 1.

Once steps 1 through 3 are completed, the DMA controller is programmed to acknowledge requests. If analog input DMA is programmed, the DMA controller automatically reads the ADC FIFO Register whenever an A/D conversion result is available and then stores the result in a buffer in memory. If the DMA controller has been programmed for analog output updating, values from the buffer in memory are automatically written to the DAC upon receipt of a DMA request. If both analog input and output DMA is selected, then the DMA controller reads the FIFO or writes to the DACs depending on which channel requested a DMA transfer.

If single-channel interleaved DMA is selected for writing data to the DACs, then one buffer services both DAC 0 and DAC 1. This is accomplished by interleaving the data in the buffer. The first location in the buffer should hold the first value to be transferred to DAC 0, the second should hold the first value to be transferred to DAC 1, the third should hold the second value to be transferred to DAC 0, and so on.

If dual-channel DMA operation has been selected for DMA requesting service, DMA Channel A and memory buffer A (DMA A) are served first. When a DMA terminal count is received, the board automatically switches the DMA operation to DMA Channel B and memory buffer B (DMA B). Therefore, the board can collect data to or from one buffer and simultaneously service data in another buffer. If the DMA controller is programmed for auto-reinitialize mode, DMA A and DMA B are continuously served in turn.

If dual-channel DMA operation has been selected to service both analog outputs, memory buffer A (DMA Channel A) and memory buffer B (DMA Channel B) are concurrently serviced, with buffer A serving DAC 0 and buffer B serving DAC 1.

## Interrupt Programming

Seven different interrupts are generated by the AT-MIO-16X board:

- Whenever a conversion is available to be read from the ADC FIFO
- Whenever the ADC FIFO is more than half-full
- Whenever a data acquisition sequence completes
- Whenever a DMA terminal count is received
- Whenever a falling edge on the TMRTRIG\* pin of the Am9513A is detected
- Whenever the DAC FIFO is less than full
- Whenever the DAC FIFO is half-full

These interrupts can be enabled either individually or in any combination. In any of the interrupt modes, it is a good practice to confirm the source of the interrupt through reading Status Register 1. If ADC FIFOEF\* or ADC FIFOHF\* is true, a conversion interrupt has occurred. Reading from the ADC FIFO Register clears these interrupt conditions. Writing to the DAQ Clear Register also clears these conversion interrupts. If DAQCOMP is set, the interrupt results from the completion of a data acquisition operation. This interrupt is cleared by writing to the DAQ Clear Register. If TMRREQ is set, a DAC update interrupt has occurred. Writing to the TMRREQ Clear Register clears this interrupt condition. In the case that waveform generation is disabled in Command Register 2, the DACs are not updated and the TMRREQ signal can be used as a timer interrupt. If DMATCA or DMATCB is set, a DMATC INT has occurred on either DMA Channel A or B. Writing to the DMATCA or DMATCB Clear Register clears this interrupt condition.

# Calibration Procedures

---

*Chapter*

**6**

This chapter discusses the calibration resources and procedures for the AT-MIO-16X analog input and analog output circuitry.

The calibration process involves reading offset and gain errors from the analog input and analog output sections and writing values to the appropriate calibration DACs to null out the errors. There are five calibration DACs associated with the analog input section, and four calibration DACs with the analog output section; two for each output channel. After the calibration process is complete, each calibration DAC is at a known value. Because these values are lost when the board is powered down, they are also stored in the onboard EEPROM for future referencing. Figure 6-1 shows where information is stored in the EEPROM.

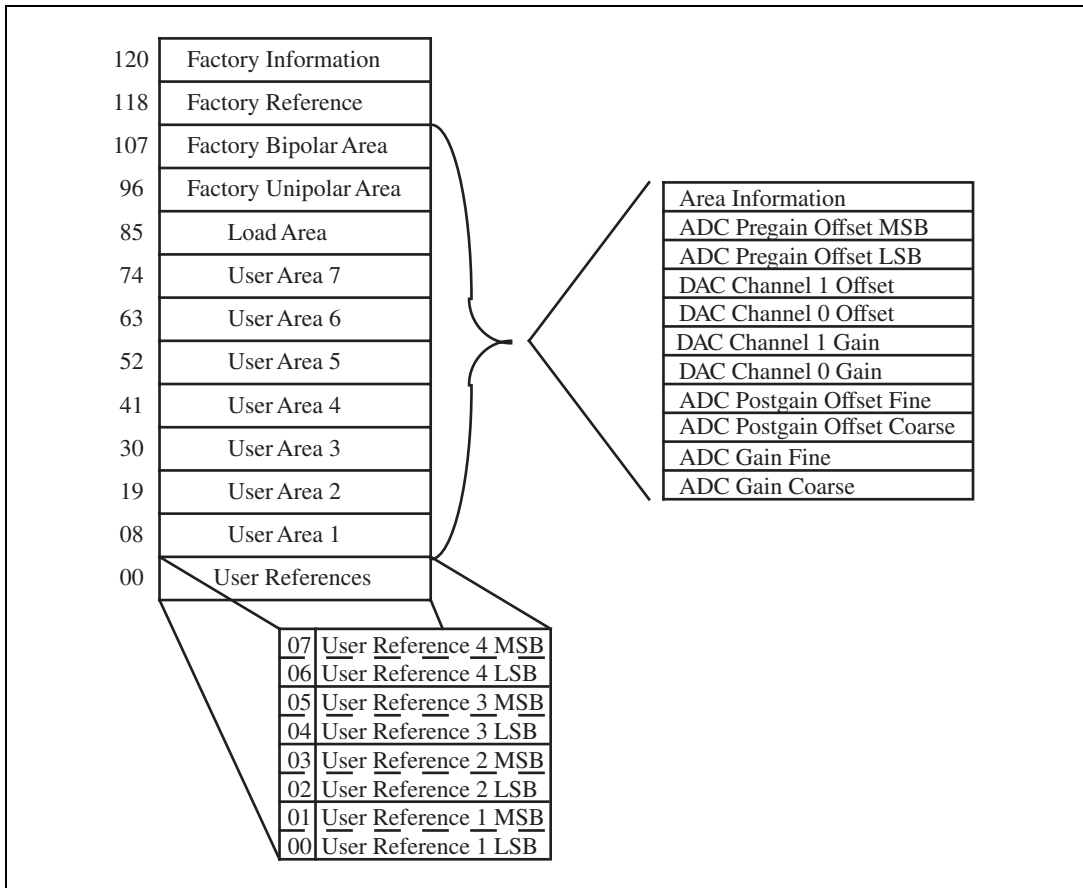

**Figure 6-1.** AT-MIO-16X EEPROM Map

The AT-MIO-16X is factory calibrated before shipment, and the associated calibration constants are stored in the factory area of the EEPROM. Table 6-1 lists what is stored in the EEPROM factory area.

**Table 6-1.** EEPROM Factory Area Information

Location	Location Description
127	Year of reference calibration (for example, 92 = 1992)
126	Month of reference calibration (for example, 2 = February)
125	Day of reference calibration (for example, 29 = 29th)

**Table 6-1.** EEPROM Factory Area Information (Continued)

<b>Location</b>	<b>Location Description</b>
124	Reserved
123	Board Code (AT-MIO-16X = 2)
122	Revision and Sub-Revision Field
121	Configuration Memory Depth
120	ADC and DAC FIFO Depths
119	Factory Reference Value MSB
118	Factory Reference Value LSB
117	Area Information
116	Factory ADC Bipolar Pregain Offset MSB
115	Factory ADC Bipolar Pregain Offset LSB
114	Factory DAC Channel 1 Bipolar Offset
113	Factory DAC Channel 0 Bipolar Offset
112	Factory DAC Channel 1 Bipolar Gain
111	Factory DAC Channel 0 Bipolar Gain
110	Factory ADC Bipolar Postgain Offset Fine
109	Factory ADC Bipolar Postgain Offset Coarse
108	Factory ADC Bipolar Gain Fine
107	Factory ADC Bipolar Gain Coarse
106	Area Information
105	Factory ADC Unipolar Pregain Offset MSB
104	Factory ADC Unipolar Pregain Offset LSB
103	Factory DAC Channel 1 Unipolar Offset

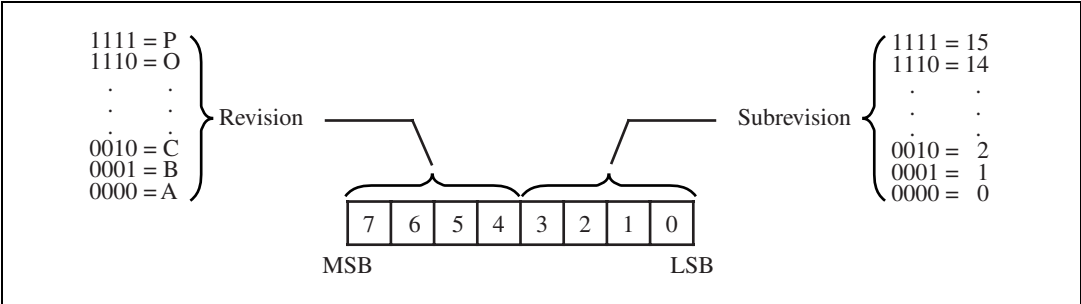

**Table 6-1.** EEPROM Factory Area Information (Continued)

<b>Location</b>	<b>Location Description</b>
102	Factory DAC Channel 0 Unipolar Offset
101	Factory DAC Channel 1 Unipolar Gain
100	Factory DAC Channel 0 Unipolar Gain
99	Factory ADC Unipolar Postgain Offset Fine
98	Factory ADC Unipolar Postgain Offset Coarse
97	Factory ADC Unipolar Gain Fine
96	Factory ADC Unipolar Gain Coarse

When the AT-MIO-16X board is powered on, or the conditions under which it is operating change, the calibration DACs should be loaded with values from the EEPROM, or if desired, the board can be recalibrated. The AT-MIO-16X calibration process is not difficult or lengthy, and requires no external equipment (other than wires to connect the analog output to the analog input). Calibration is performed by calling the MIO\_Calibrate function in NI-DAQ. The function calibrates the board and performs the necessary EEPROM reads and writes and calibration DAC writes.

The EEPROM is a 128-bit by 8-bit storage area which contains a permanent storage area and a modifiable storage area. The permanent storage area consists of locations 96 through 127. While at the factory, these locations can be accessed for a read or a write operation, but in the field, these locations can only be read from. These locations cannot and should not be written to. This allows for a permanent set of calibration values that cannot be erased. The modifiable area consists of locations 0 through 95. These locations can always be read from and written to. Included in this area are the load area, user areas, and user reference areas. Notice that the load area contains constants that are loaded at initialization by the software to place the board in a known and calibrated state.



**Figure 6-2.** Revision and Subrevision Field

If the Revision and Subrevision Field contain the binary value 00100010, this signifies that the accessed AT-MIO-16X board is at Revision C and Subrevision 2. This number can be very useful in tracking boards in the field and in answering questions concerning board operation. Board operation sometimes varies depending on the revision or subrevision of the board.

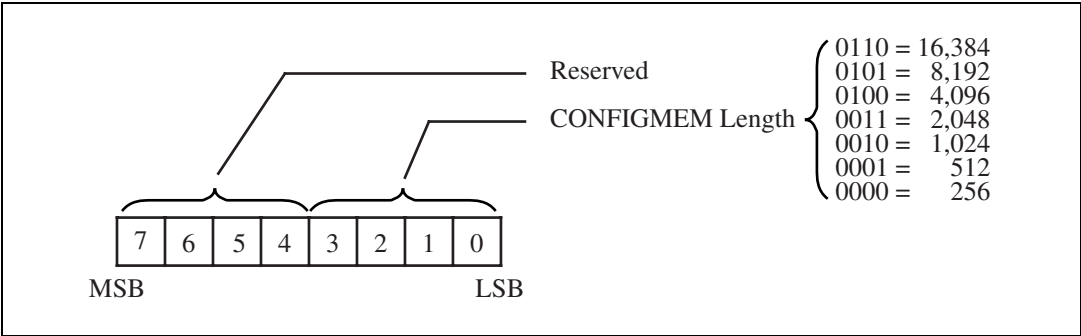

**Figure 6-3.** Configuration Memory Depth Field

If the Configuration Memory Depth Field contains the binary value XXXX0001 where X indicates don't care bits, this signifies that the accessed AT-MIO-16X board contains a configuration memory with a depth of 512. Thus, the configuration memory can hold up to 512 configuration values for channel, gain, mode, and range settings.

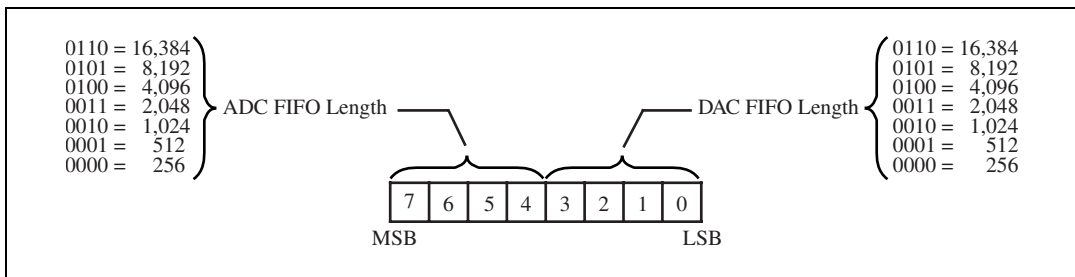

**Figure 6-4.** ADC and DAC FIFO Depth Field

If the ADC and DAC FIFO Depth Field contains the binary value 00010011, then the AT-MIO-16X board that was accessed contains an ADC FIFO buffer of depth 512 and a DAC FIFO buffer of depth 2,048. This information is extremely useful in determining how many values to read from the ADC FIFO or write to the DAC FIFO when a half-full interrupt is generated. For example, if it is known that the ADC FIFO is 512 values deep and a half-full interrupt is generated, then 256 values can be read in at once without checking the Status Register 0 to see if the FIFO contains values. Alternately, if the DAC FIFO is 2,048 values deep and a half-full interrupt is generated, then 1,024 values can be read. This can have a significant performance impact on software speed.

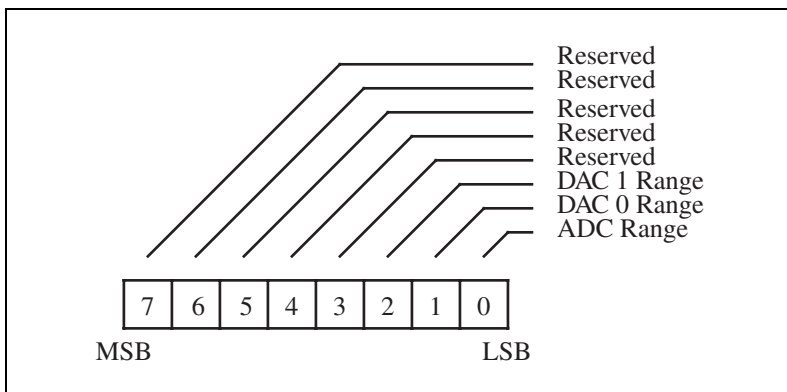

**Figure 6-5.** Area Information Field

If the Area Information Field contains the binary value XXXXX101 where X indicates don't care bits, then the area described by this area information value contains bipolar DAC 1 calibration constants, unipolar DAC 0 calibration constants, and bipolar ADC calibration constants. The area information value for the factory bipolar area will always be XXXXX111, and for the factory unipolar area it will always

be XXXXX000. If the analog input section is calibrated using the utility library functions and the constants are saved to User Area 7, then the ADC Range bit in the area information field for User Area 7 is set or cleared according to the mode in which the analog input section was calibrated. The same holds true for the analog output section.

## Calibration Equipment Requirements

---

Normal self-calibration requires no external calibration equipment. However, because the internal voltage reference drifts slightly with time and temperature, it may be necessary to redetermine its value every year, or whenever operating the board at an ambient temperature that is more than 10° C from the temperature at which the reference value was last determined. The value of the reference is initially determined at the factory at a room temperature of 25° C. After the value of the reference is determined, the value should be stored in the EEPROM so that it can be used by the input and output calibration routines. The calibration procedure which determines the reference value is explained in the *Reference Calibration* section later in this chapter. Locations have been provided in the EEPROM to accommodate user calibration constants (see Figure 6-1).

For best measurement results, the AT-MIO-16X onboard reference needs to be measured to  $\pm 0.0015\%$  ( $\pm 15$  ppm) accuracy. According to standard practice, the equipment used to calibrate the AT-MIO-16X should be 10 times as accurate; that is, the equipment should have  $\pm 0.00015\%$  ( $\pm 1.5$  ppm) rated accuracy. Practically speaking, calibration equipment with four times the accuracy of the item under calibration is generally considered acceptable. Four times the accuracy of the AT-MIO-16X is  $\pm 0.000375\%$  ( $\pm 3.75$  ppm). To redetermine the value of the reference on the AT-MIO-16X board you will need the following equipment:

A precision DC voltage source (usually a calibrator):

Voltage: 5.0 to 9.99 V

Accuracy:  $\pm 0.00015\%$  ( $\pm 1.5$  ppm) standard  
 $\pm 0.000375\%$  ( $\pm 3.75$  ppm) standard

It is important to realize that inaccuracy of the internal voltage reference results only in gain error. Offset error is unaffected. If an application can tolerate slight gain inaccuracy, there should not be a need to redetermine the value of the onboard reference.

## Calibration DACs

There are eight 8-bit DACs (CALDAC<0..7>) and one 12-bit DAC (CALDAC8) on the AT-MIO-16X that are used for calibration. These DACs are described in Table 6-2.

**Table 6-2.** Calibration DACs

Analog	DAC	Function	Adjustment Range	Incremental Effect
Input	CALDAC0	Coarse gain trim	$\pm 1169$ ppm	$-9.13$ ppm
	CALDAC1	Fine gain trim	$\pm 65.1$ ppm	$-0.509$ ppm
	CALDAC2	Coarse postgain offset trim	$\pm 51.8$ ppm	$404$ $\mu$ V
	CALDAC3	Fine postgain offset trim	$\pm 512$ $\mu$ V	$4.00$ $\mu$ V
	CALDAC8	Pregain offset trim	$\pm 1.2$ $\mu$ V	$0.586$ $\mu$ V
Output	CALDAC4	DAC0 gain trim	$\pm 976$ ppm	$7.62$ ppm
	CALDAC5	DAC1 gain trim	$\pm 976$ ppm	$7.62$ ppm
	CALDAC6	DAC0 offset trim	$\pm 4.86$ mV	$38.0$ $\mu$ V
	CALDAC7	DAC1 offset trim	$\pm 4.86$ mV	$38.0$ $\mu$ V

## Reference Calibration

The AT-MIO-16X has a stable voltage reference to which gain can be calibrated. The value of this voltage reference is determined through the reference calibration routine, which requires a known external voltage between 5 and 9.99 V to be connected differentially on any desired input channel. The routine calibrates the circuitry to the external reference and then reads the internal reference. This value is stored as

a two's complement binary number in the onboard EEPROM for subsequent use by the analog input calibration routines.

Because the onboard reference is very stable with respect to time and temperature, it is seldom necessary to use the reference calibration routine. Every year should be sufficient, or whenever operating the board at an ambient temperature that is more than 10° C from the temperature at which the reference value was last determined. Factory calibration is performed at approximately 25° C.

## Analog Input Calibration

---

To null out error sources that compromise the quality of measurements, the input calibration routine calibrates the analog input circuitry by adjusting the following potential sources of error:

- Pregain offset (offset error at the input of the PGIA)
- Postgain offset (offset error at the input of the ADC)
- Gain error of the analog input circuitry

Pregain offset contributes gain-dependent error to the analog input system. This offset is multiplied by the gain of the PGIA. To calibrate this offset, the routine grounds the inputs of the PGIA, measures the input at two different gains, and adjusts CALDAC8 until the measured offset in LSBs is independent of the gain setting.

Postgain offset is the total of the voltage offsets contributed by the circuitry from the output of the PGIA to the ADC input (including the ADC's own offsets). To calibrate this offset, the routine grounds the inputs of the PGIA and adjusts CALDAC2 and CALDAC3 until the offset is within a small fraction of an LSB. The postgain offset is always calibrated immediately after the pregain offset is calibrated.

If the three offset DACs are adjusted in this way, there is no significant residual offset error, and reading a grounded channel returns (on average) less than  $\pm 0.5$  LSB, regardless of gain setting.

All the stages up to and including the input of the ADC contribute to the gain error of the analog input circuitry. With the PGIA set to a gain of 1, the gain of the analog input circuitry is ideally 1. The gain error is the deviation of the gain from 1 and appears as a multiplication of the input voltage being measured. To eliminate this error source, the routine measures the internal voltage reference and adjusts CALDAC0 and

CALDAC1 until the measured voltage is equal to the value of the reference as stored in the onboard EEPROM. Once the board is calibrated at a gain of 1, there is only a small residual gain error ( $\pm 0.02\%$  maximum) at the other gains. The gain error is always calibrated immediately after the offsets are calibrated.

## Analog Output Calibration

---

To null out error sources that affect the accuracy of the output voltages generated, the output calibration routine calibrates the analog output circuitry by adjusting the following potential sources of error:

- Analog output offset error
- Analog output gain error

In order to read the analog output voltages, the output calibration routine requires that the AT-MIO-16X analog outputs be wrapped back to the analog inputs as follows:

1. Connect DAC0 to a channel in ACH<0..7>
2. Connect DAC1 to another channel in ACH<0..7>
3. Connect AO GND to the negative sides of the channels selected in steps 1 and 2. Do not tie AO GND to AI GND as this will complete a ground loop, potentially introducing offset calibration errors of several LSBs.

The output calibration routines require that the input is already calibrated, because it uses the input circuitry as the source of calibration.

Offset error in the analog output circuitry is the total of the voltage offsets contributed by the components in the output circuitry. This error, which is independent of the DAC output voltage, is the amount of voltage generated by the DAC when it is set to produce 0 V. To correct this offset error, the routine writes a value of 0 to each DAC and adjusts CALDAC6 and CALDAC7 until it measures 0 V between each analog output and AO GND.

Gain error in the analog output circuitry is the sum of the gain errors contributed by the components in the output circuitry. This error is a voltage difference between the desired voltage and the actual output voltage generated that is proportional to the DAC output voltage. To correct the gain error, the output calibration routine sets each analog

output to 5 V and adjusts CALDAC4 and CALDAC5 until it measures 5 V between each analog output and AO GND. The gain error is always calibrated immediately after the offset is calibrated. Notice that CALDAC4 and CALDAC5 adjust the gain by varying the values of the internal DAC references. Hence, the gain of an analog output channel cannot be adjusted under software control if the channel is using an external reference (but the offset can still be adjusted).



# Specifications

---

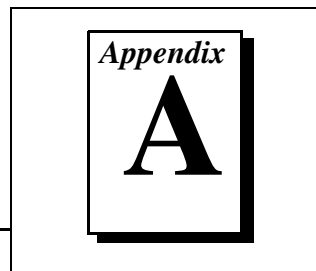

This appendix lists the specifications of the AT-MIO-16X. These are typical at 25° C unless otherwise stated. The operating temperature range is 0° to 70° C. A warmup time of at least 15 minutes is required.

## Analog Input

---

Number of input channels .....	16 single-ended, 8 differential
Analog resolution .....	16-bit, 1 in 65,536
Maximum sampling rate .....	100 ksamples/sec
Relative accuracy .....	±1.5 LSB maximum over temperature, ±0.75 LSB typical
Differential nonlinearity (DNL) .....	±1 LSB maximum (no missing codes over temperature, ±0.5 LSB typical
Differential analog input ranges .....	±10 V or 0 to +10 V, software-selectable
Common-mode input range .....	Each input to the instrumentation amplifier should remain within ±11 V of AIGND at any gain or range
Overvoltage protection (ACH0 to ACH15 and AISENSE) .....	±15 V power off, ±25 V power on
Common-mode rejection ratio .....	105 dB, all gains DC to 60 Hz
Bandwidth (–3 dB) .....	DC to 255 kHz, all gains
Input bias current .....	±1 nA

Input impedance .....	100 G $\Omega$ in parallel with 100 pF
Gains .....	1, 2, 5, 10, 20, 50, and 100, software-selectable
Pregain offset error	
After calibration .....	$\pm 3$ $\mu$ V maximum
Before calibration .....	$\pm 2.2$ mV maximum
Temperature coefficient .....	$\pm 5$ $\mu$ V/ $^{\circ}$ C
Postgain offset error	
After calibration .....	$\pm 381$ $\mu$ V maximum
Before calibration .....	$\pm 102$ mV maximum
Temperature coefficient .....	$\pm 120$ $\mu$ V/ $^{\circ}$ C
Gain error (relative to reference)	
After calibration .....	$\pm 0.00366\%$ (36.6 ppm) maximum
Before calibration (any gain) .....	$\pm 0.215\%$ (2,150 ppm) maximum
Gain $\neq 1$ .....	$\pm 0.02\%$ (200 ppm) maximum, with gain error adjusted to 0 at gain = 1
Temperature coefficient (any gain) .....	$\pm 8$ ppm/ $^{\circ}$ C
System noise (including quantization noise)	
Bipolar ( $\pm 10$ V range) .....	0.6 LSB rms for gain 1 to 10 0.7 LSB rms for gain 20 1.1 LSB rms for gain 50 2.0 LSB rms for gain 100
Unipolar (0 to 10 V range) .....	0.8 LSB rms for gains 1 to 10 1.1 LSB rms for gain 20 2.0 LSB rms for gain 50 3.8 LSB rms for gain 100
Crosstalk (other than from settling) ....	$-70$ dB (DC to 100 kHz)
Onboard reference .....	5.000 V ( $\pm 2$ mV)
Temperature coefficient .....	2 ppm/ $^{\circ}$ C maximum (10 $\mu$ V/ $^{\circ}$ C maximum)

$$\text{Long-term stability} \dots\dots\dots 15 \text{ ppm } \sqrt{1,000 \text{ h}}$$

$$(75 \mu\text{V} / \sqrt{1,000 \text{ h}})$$

## Explanation of Analog Input Specifications

### Linear Errors

*Pregain offset error* is the amount of possible voltage offset error in the circuitry before the gain stage. Its contribution to total offset error is multiplied by the gain.

*Postgain offset error* is the amount of possible voltage offset error in the circuitry following the gain stage. Its contribution to total offset error is not multiplied by the gain. The total offset error is the postgain offset error plus the gain times the pregain offset error.

*Gain error* is the amount of possible deviation from ideal gain, expressed as a proportion of the gain.

The total linear measurement error for a given input voltage takes into account all gain and offset errors but does not include any nonlinear errors (such as relative accuracy). It is the sum of the gain error times the input voltage, the gain times the pregain offset error, and the postgain offset error.

Tables A-1 and A-2 list equivalent offset and gain errors for 16-bit ADC systems and may be useful for comparing systems. They also apply to 16-bit DAC systems.

**Table A-1.** Equivalent Offset Errors in 16-Bit Systems

Range	LSB	Voltage	% of FSR
0 to 10 V	1	152.6 $\mu\text{V}$	0.001526%
-10 to 10 V	1	305.2 $\mu\text{V}$	0.001526%

**Table A-2.** Equivalent Gain Errors in 16-Bit Systems

Range	Error at Full-Scale		Gain Error	
	LSB	% of FSR	% of Gain	PPM of Gain
0 to 10 V	1	0.001526%	0.001526%	15.26 ppm
-10 to 10 V	1	0.001526%	0.003052%	30.52 ppm

## Nonlinear Errors

*Relative accuracy* is a measure of the (non)linearity of an analog system. It indicates the maximum deviation of the averaged analog-input-to-digital-output transfer curve from an endpoint-fit straight line. If the analog circuitry has been calibrated perfectly, then the endpoint-fit straight line is the ideal transfer function, and the relative accuracy specification indicates the farthest deviation from the ideal that the system permits.

*Differential nonlinearity* (DNL) is a measure of deviation of code widths from their theoretical value of 1 LSB. The width of a given code is the size of the range of analog values that can be input to produce that code, ideally 1 LSB. A specification of  $\pm 1$  LSB differential nonlinearity ensures that no code has a width of 0 LSBs (that is, no missing codes) and that no code width exceeds 2 LSBs. DNL is measured using histograms.

## Noise

*System noise* is the amount of noise (in LSB rms) in the ADC data when there is no signal present at the input of the board. This figure includes the quantization noise of the ADC.

# Analog Data Acquisition Rates

---

## Single-Channel Acquisition Rates

The maximum single-channel data acquisition rate of the AT-MIO-16X is 100 ksamples/sec (10- $\mu$ sec sample period). The AT-MIO-16X may run as fast as 111 ksamples/sec (9- $\mu$ sec sample period), but with unspecified accuracy.

## Multiple-Channel Scanning Acquisition Rates

When scanning among channels with different voltages, the analog circuitry on the AT-MIO-16X needs time to settle from one voltage to the next. Because of its complex transient response, the AT-MIO-16X is not always able to settle to full 16-bit accuracy within 10  $\mu$ sec, which is the shortest guaranteed sampling interval. Table A-3 lists the typical voltage settling times to within three different percentages of full-scale range.

**Table A-3.** Typical Multiple-Channel Scanning Settling Times

Accuracy	$\pm 0.0061\%$ FSR ( $\pm 4$ LSB)	$\pm 0.0015\%$ FSR ( $\pm 1$ LSB)	$\pm 0.00076\%$ FSR ( $\pm 0.5$ LSB)
Typical settling time	10 $\mu$ sec	20 $\mu$ sec	40 $\mu$ sec
Maximum per-channel acquisition rate	100 ksamples/sec	50 ksamples/sec	25 ksamples/sec

When scanning among channels at various gains, the settling times may further increase. The settling times given in Table A-3 are for signals changing from and to voltages within in the same full-scale range. When the PGIA switches to a higher gain, the signal on the previous channel may be well outside the new, smaller range. For instance, suppose a 4-V signal is connected to Channel 0 and a 1-mV signal is connected to Channel 1, and suppose the PGIA is programmed to apply a gain of 1 to Channel 0 and a gain of 100 to Channel 1. When the multiplexer switches to Channel 1 and the PGIA switches to a gain of 100, the new full-scale range is  $\pm 100$  mV (if the ADC is in bipolar mode). The approximately 4-V step from 4 V to 1 mV is 2,000% of the new full-scale range. To settle within 0.0015% (15 ppm) of the  $\pm 100$  mV full-scale range on Channel 1, the input circuitry has to settle to within 0.000075% (0.75 ppm) of the 4-V step. It may take as long as 4,000  $\mu$ sec for the circuitry to settle this much. In general this extra settling time is not needed when the PGIA is switching to a lower gain.

Because of the problems with settling times, multiple-channel scanning is not recommended unless sampling rates are low enough or it is necessary to simultaneously sample several signals as close as possible. The data is much more accurate (and channel-to-channel independent) if you acquire data from each channel independently (for example, 100 points from Channel 0, then 100 points from Channel 1, then 100 points from Channel 2, and so on). If, however, all the channels are scanned at

the same gain and all the signals are within 10% of the full-scale range of each other (for example, within 2 V of each other with a  $\pm 10$ -V range), the circuitry settles to full 16-bit accuracy ( $\pm 0.5$  LSB) in 10  $\mu$ sec and the channels can be scanned at the full rate of 100 ksamples/sec.

## Analog Output

---

Number of output channels .....	2
Type of DAC.....	16-bit, multiplying
Data transfers .....	DMA, programmed I/O, or interrupts
Maximum update rate.....	100 ksamples/sec
Relative accuracy (nonlinearity).....	$\pm 4$ LSB maximum, $\pm 2$ LSB typical, bipolar $\pm 8$ LSB maximum, $\pm 4$ LSB typical, bipolar
Differential nonlinearity.....	$\pm 0.5$ LSB maximum (monotonic over temperature)
Offset error	
After calibration .....	$\pm 305$ $\mu$ V maximum
Before calibration .....	$\pm 8.15$ mV maximum
Temperature coefficient.....	$\pm 50$ $\mu$ V/ $^{\circ}$ C
Gain error	
Using internal reference	
After calibration.....	$\pm 0.0061\%$ (61 ppm) maximum
Before calibration .....	$\pm 0.182\%$ (1,820 ppm) maximum
Temperature coefficient .....	$\pm 7.3$ ppm/ $^{\circ}$ C
Using external reference .....	$\pm 0.15\%$ (1,500 ppm), not adjustable
Temperature coefficient .....	$\pm 7.3$ ppm/ $^{\circ}$ C
Onboard reference	
Temperature coefficient.....	2 ppm/ $^{\circ}$ C maximum
Long-term stability .....	15 ppm $\sqrt{1,000}$ h

Output voltage ranges .....	0 to 10 V, unipolar mode; ±10 V, bipolar mode, (software-selectable)
Current drive capability .....	±5 mA (short-circuit protected) 2 k $\Omega$ minimum load, 1,000 pF maximum capacitive load
Output settling time to ±0.003% FSR.....	10 $\mu$ sec for a 20 V step
Output slew rate.....	5 V/ $\mu$ sec
Output noise .....	50 $\mu$ V rms, DC to 1 MHz
Output impedance .....	0.3 $\Omega$
External reference input impedance ....	10 k $\Omega$
External reference input range .....	±18 V (protected to ±30 V, power on or off)
External reference bandwidth (–3 dB) .....	DC to 300 kHz

## Explanation of Analog Output Specifications

*Offset error* is the amount of possible voltage offset error in the analog output circuitry, expressed in mV.

*Gain error* is the amount of possible deviation from ideal gain of the analog output circuitry, expressed as a proportion of the gain.

The total linear error for a DAC at a given output voltage is the output voltage times the gain error, plus the offset error.

*Relative accuracy* in a DAC is the same as integral nonlinearity because no uncertainty is added by quantization. Unlike an ADC, every digital code in a DAC represents a specific analog value rather than a range of values. The relative accuracy of the system is therefore limited to the worst-case deviation from the ideal correspondence (a straight line), excepting noise. If a DAC has been perfectly calibrated, then the relative accuracy specification reflects its worst-case absolute error.

*Differential nonlinearity* in a DAC is a measure of deviation of code width from 1 LSB. For a DAC, code width is the difference between the analog values produced by consecutive digital codes. A specification of  $\pm 0.5$  LSB differential nonlinearity ensure that the code width is always greater than 0.5 LSB (guaranteeing monotonicity) and less than 1.5 LSB.

## Digital I/O

---

Compatibility .....	TTL-compatible
Output current source capability.....	Can source 2.6 mA at $V_{OH}$ at 2.4 V min
Output current sink capability .....	Can sink 24 mA at $V_{OL}$ at 0.5 V max

## Timing I/O

---

Number of channels .....	3 counter/timers 1 frequency output
Resolution .....	16-bit for 3 counter/timers, 4-bit for frequency output channel
Base clock available .....	5 MHz, 1 MHz, 100 kHz, 10 kHz, 1 kHz, 100 Hz
Base clock accuracy .....	$\pm 0.01\%$
Compatibility .....	TTL-compatible inputs and outputs. Counter gate and source inputs are pulled up with 4.7-k $\Omega$ resistors onboard.
Counter input frequency .....	6.9 MHz maximum (145-nsec period) with a minimum pulse width of 70 nsec



## Power Requirement (from PC I/O Channel)

---

Power consumption.....2.0 A typical at +5 VDC  
Power available at I/O connector .....4.75 V to 5.25 V at 1 A

## Physical

---

Board dimensions .....13.3 by 4.5 in.  
I/O connector .....50-pin male ribbon-cable  
connector or 68-pin male  
shielded cable connector

## Environment

---

Operating component temperature .....0° to +70° C  
Storage Temperature .....-55° to +150° C  
Relative humidity .....5% to 90% noncondensing

# I/O Connector

---

The logo for Appendix B, featuring the word "Appendix" in a serif font above a large, bold, serif letter "B". The text is contained within a rectangular frame with a double-line border.

This appendix describes the pinout and signal names for the AT-MIO-16X 50-pin I/O connector and the 68-pin I/O connector.

Figure B-1 shows the AT-MIO-16X 50-pin I/O connector.

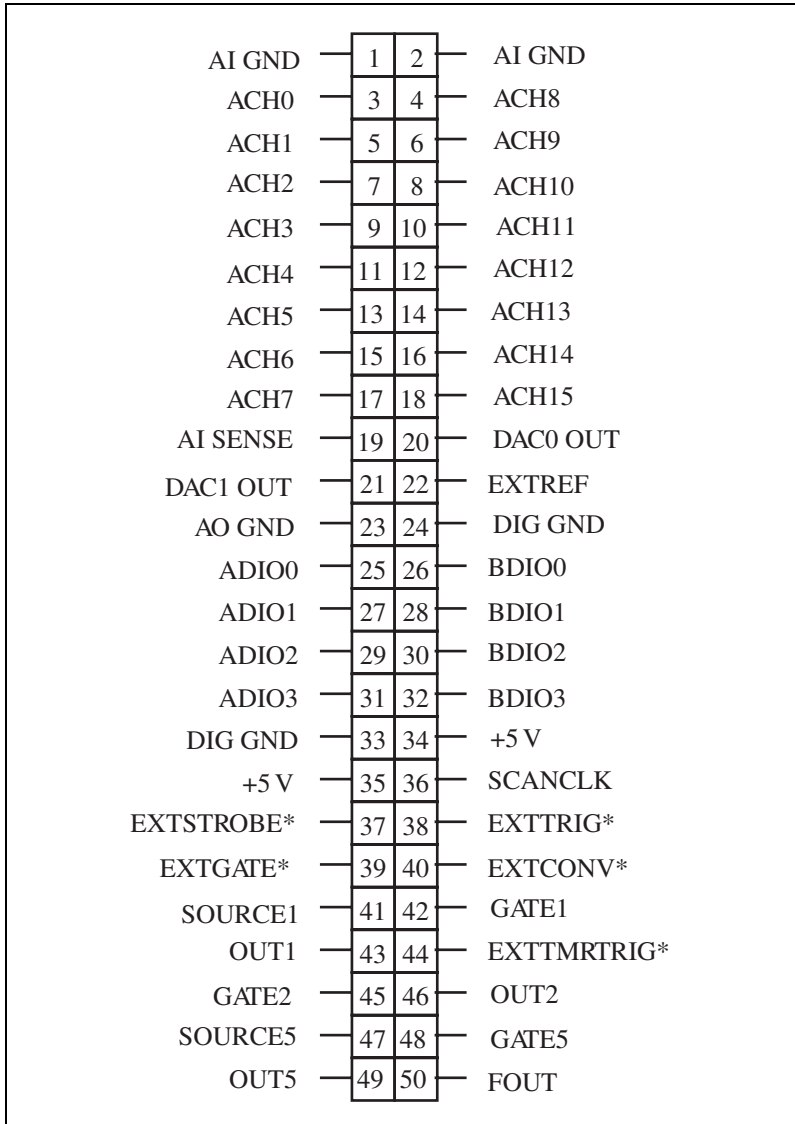
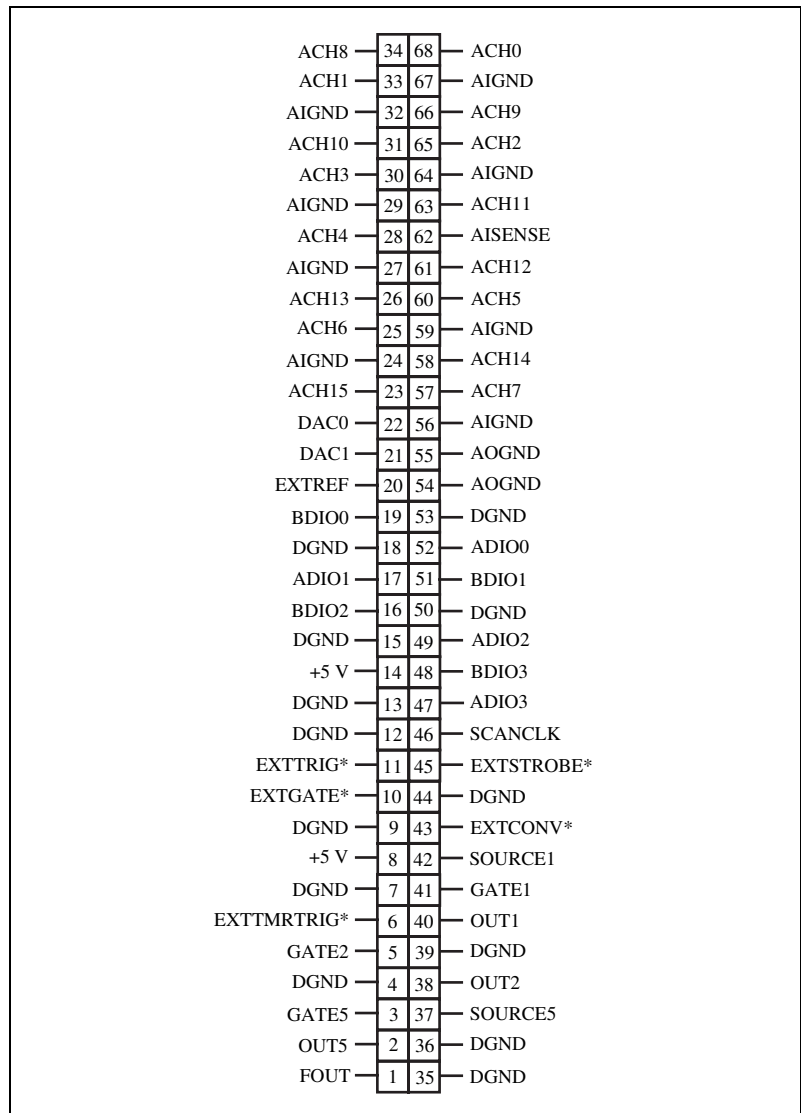

Figure B-1. AT-MIO-16X 50-Pin I/O Connector

Figure B-2 shows the pin assignments for the AT-MIO-16X 68-pin I/O connector.



**Figure B-2.** AT-MIO-16X 68-Pin I/O Connector

**Table B-1.** Signal Connection Descriptions

68-Pin Pins	50-Pin Pins	Signal Names	Descriptions
24, 27, 29, 32, 56, 59, 64, 67	1-2	AI GND	Analog Input Ground—These pins are the reference point for single-ended measurements and the bias current return point for differential measurements.
68, 33, 65, 30, 28, 60, 25, 57, 34, 66, 31, 63, 61, 26, 58, 23	3-18	ACH<0..15>	Analog Input Channels 0 through 15—In differential mode, the input is configured for up to eight channels. In single-ended mode, the input is configured for up to 16 channels.
62	19	AI SENSE	Analog Input Sense—This pin serves as the reference node when the board is in NRSE configuration. If desired, this signal can be programmed to be driven by the board analog input ground in the DIFF and RSE analog input modes.
22	20	DAC0 OUT	Analog Channel 0 Output—This pin supplies the voltage output of analog output Channel 0.
21	21	DAC1 OUT	Analog Channel 1 Output—This pin supplies the voltage output of analog output Channel 1.
20	22	EXTREF	External Reference—This is the external reference input for the analog output circuitry.
54, 55	23	AO GND	Analog Output Ground—The analog output voltages are referenced to this node.
4, 7, 9, 12, 13, 15, 18, 35, 36, 39, 44, 50, 53	24, 33	DIG GND	Digital Ground—This pin supplies the reference for the digital signals at the I/O connector as well as the +5 VDC supply.
52, 17, 49, 47	25, 27, 29, 31	ADIO<0..3>	Digital I/O port A signals.
19, 51, 16, 48	26, 28, 30, 32	BDIO<0..3>	Digital I/O port B signals.

**Table B-1.** Signal Connection Descriptions (Continued)

68-Pin Pins	50-Pin Pins	Signal Names	Descriptions
8, 14	34, 35	+5 V	+5 VDC Source—These pins are fused for up to 1 A of +5 V supply.
46	36	SCANCLK	Scan Clock—This pin pulses once for each A/D conversion in the scanning modes. The low-to-high edge indicates when the input signal can be removed from the input or switched to another signal.
45	37	EXTSTROBE*	External Strobe—Writing to the EXTSTROBE Register results in a minimum 500-nsec low pulse on this pin.
11	38	EXTTRIG*	External Trigger—In posttrigger data acquisition sequences, a high-to-low edge on EXTTRIG* initiates the sequence. In pretrigger applications, the first high-to-low edge of EXTTRIG* initiates pretrigger conversions while the second high-to-low edge initiates the posttrigger sequence.
10	39	EXTGATE*	External Gate—When EXTGATE* is low, A/D conversions are inhibited. When EXTGATE* is high, A/D conversions are enabled.
43	40	EXTCONV*	External Convert—A high-to-low edge on EXTCONV* causes an A/D conversion to occur. Conversions initiated by the EXTCONV* signal are inhibited outside of a data acquisition sequence, and when gated off.
42	41	SOURCE1	SOURCE1—This pin is from the Am9513A Counter 1 signal.
41	42	GATE1	GATE1—This pin is from the Am9513A Counter 1 signal.

**Table B-1.** Signal Connection Descriptions (Continued)

<b>68-Pin Pins</b>	<b>50-Pin Pins</b>	<b>Signal Names</b>	<b>Descriptions</b>
40	43	OUT1	OUTPUT1—This pin is from the Am9513A Counter 1 signal.
6	44	EXTTMRTRIG*	External Timer Trigger—If selected, a high-to-low edge on EXTTMRTRIG* results in the output DACs being updated with the value written to them in the posted update mode. EXTTMRTRIG* will also generate a timed interrupt if enabled.
5	45	GATE2	GATE2—This pin is from the Am9513A Counter 2 signal.
38	46	OUT2	OUTPUT2—This pin is from the Am9513A Counter 2 signal.
37	47	SOURCE5	SOURCE5—This pin is from the Am9513A Counter 5 signal.
3	48	GATE5	GATE5—This pin is from the Am9513A Counter 5 signal.
2	49	OUT5	OUT5—This pin is from the Am9513A Counter 5 signal.
1	50	FOUT	Frequency Output—This pin is from the Am9513A FOUT signal.

# AMD Am9513A Data Sheet<sup>1</sup>

---

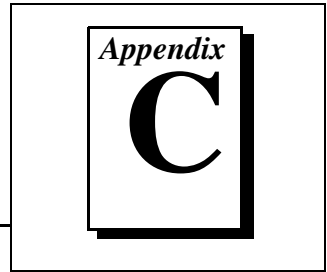

This appendix contains the manufacturer data sheet for the AMD Am9513A System Timing Controller integrated circuit (Advanced Micro Devices, Inc.) data sheet. This controller is used on the AT-MIO-16X.

---

1. Copyright © Advanced Micro Devices, Inc. 1989. Reprinted with permission of copyright owner. All rights reserved.  
Advanced Micro Devices, Inc. 1990 Data Book *Personal Computer Products: Processors, Coprocessors, Video, and Mass Storage*.



# Am9513A

## System Timing Controller

FINAL

### DISTINCTIVE CHARACTERISTICS

- Five independent 16-bit counters
- High speed counting rates
- Up/down and binary/BCD counting
- Internal oscillator frequency source
- Tapped frequency scaler
- Programmable frequency output
- 8-bit or 16-bit bus interface
- Time-of-day option
- Alarm comparators on counters 1 and 2
- Complex duty cycle outputs
- One-shot or continuous outputs
- Programmable count/gate source selection
- Programmable input and output polarities
- Programmable gating functions
- Retriggering capability
- +5 volt power supply
- Standard 40-pin package
- SMD/DESC qualified

### GENERAL DESCRIPTION

The Am9513A System Timing Controller is an LSI circuit designed to service many types of counting, sequencing and timing applications. It provides the capability for programmable frequency synthesis, high resolution programmable duty cycle waveforms, retriggerable digital one-shots, time-of-day clocking, coincidence alarms, complex pulse generation, high resolution baud rate generation, frequency shift keying, stop-watching timing, event count accumulation, waveform analysis, etc. A variety of programmable operating modes and control features allows the Am9513A to be personalized for particular applications as well as dynamically reconfigured under program control.

The STC includes five general-purpose 16-bit counters. A variety of internal frequency sources and external pins may be selected as inputs for individual counters with software selectable active-high or active-low input polarity. Both hardware and software gating of each counter is available. Three-state outputs for each counter provide pulses or levels and can be active-high or active-low. The counters can be programmed to count up or down in either binary or BCD. The host processor may read an accumulated count at any time without disturbing the counting process. Any of the counters may be internally concatenated to form any effective counter length up to 80 bits.

### BLOCK DIAGRAM

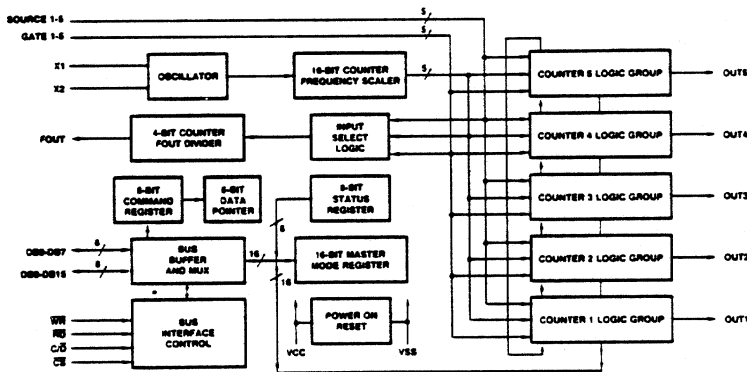

BD003381

2-116

Am9513A

Publication #	Rev.	Amendment
01731	F	/0
Issue Date: August 1988		

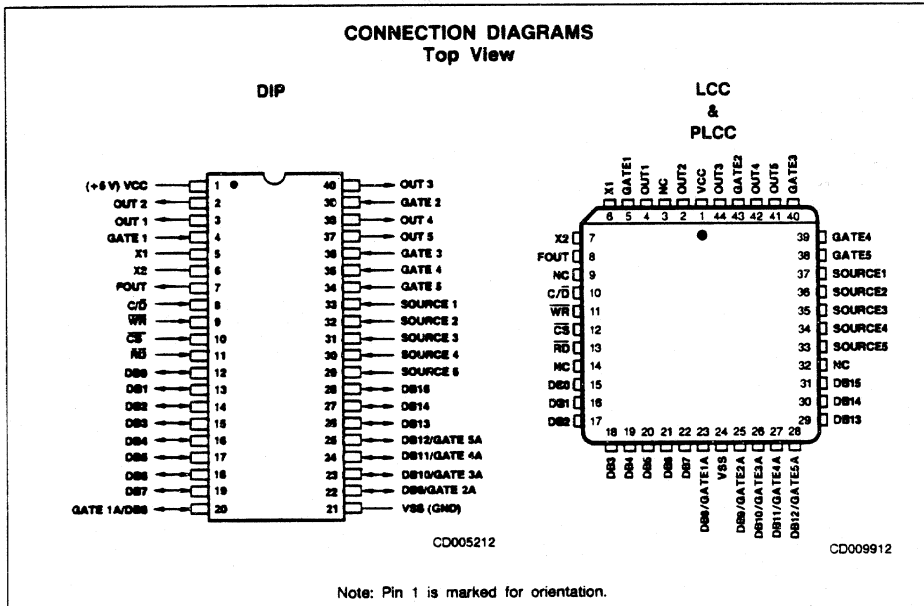

2

### ORDERING INFORMATION Standard Products

AMD standard products are available in several packages and operating ranges. The order number (Valid Combination) is formed by a combination of:

- a. Device Number
- b. Speed Option (if applicable)
- c. Package Type
- d. Temperature Range
- e. Optional Processing

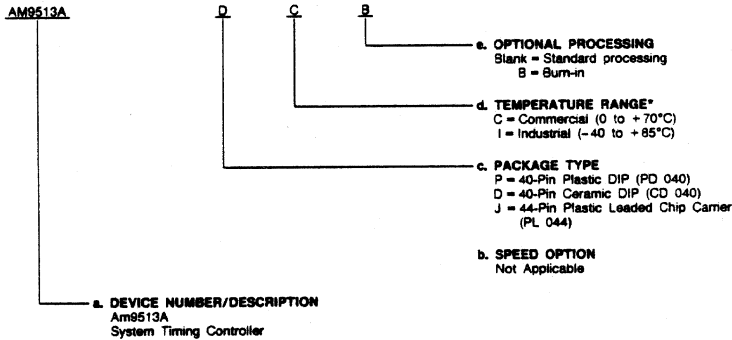

Valid Combinations	
AM9513A	PC, DC, DCB, DIB, JC

\*This device is also available in Military temperature range.

#### Valid Combinations

Valid Combinations list configurations planned to be supported in volume for this device. Consult the local AMD sales office to confirm availability of specific valid combinations, to check on newly released combinations, and to obtain additional data on AMD's standard military grade products.

**ORDERING INFORMATION (continued)**

**Standard Military Drawing (SMD)/DESC Products**

AMD products for Aerospace and Defense applications are available in several packages and operating ranges. Standard Military Drawing (SMD)/DESC products are fully compliant with MIL-STD-883C requirements. The order number (Valid Combination) for SMD/DESC products is formed by a combination of:

- a. Military Drawing Part Number
- b. Device Type
- c. Case Outline
- d. Lead Finish

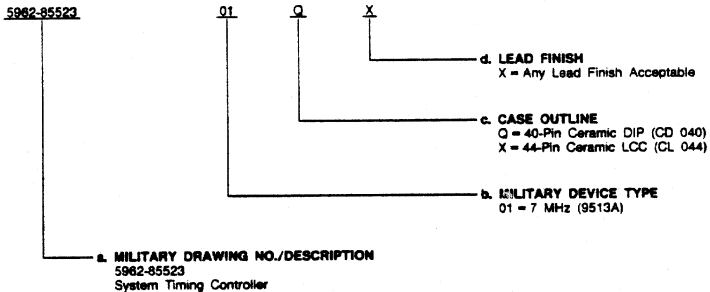

**Valid Combinations**

Valid Combinations list configurations planned to be supported in volume for this device. Consult the local AMD sales office to confirm availability of specific valid combinations or to check for newly released valid combinations.

Valid Combinations	
5962-8552301	QX, XX

**Group A Tests**

Group A tests consist of Subgroups 1, 2, 3, 7, 8, 9, 10, 11.

**ORDERING INFORMATION (continued)**

**APL Products**

AMD products for Aerospace and Defense applications are available in several packages and operating ranges. APL (Approved Products List) products are fully compliant with MIL-STD-883C requirements. The order number (Valid Combination) for APL products is formed by a combination of:

- a. Device Number
- b. Speed Option (if applicable)
- c. Device Class
- d. Package Type
- e. Lead Finish

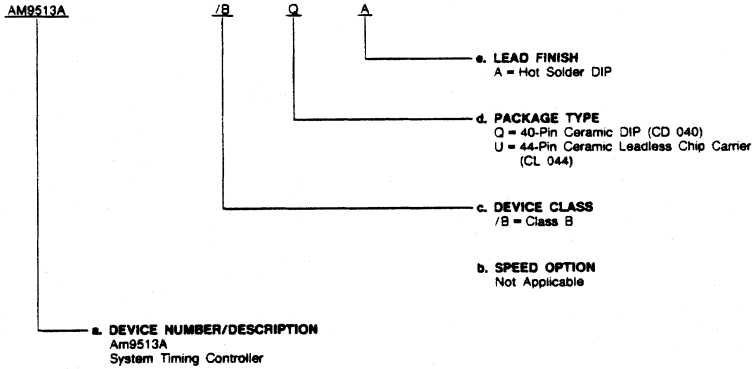

**Valid Combinations**

Valid Combinations list configurations planned to be supported in volume for this device. Consult the local AMD sales office to confirm availability of specific valid combinations or to check for newly released valid combinations.

Valid Combinations	
AM9513A	/BQA, /BUA

**Group A Tests**

Group A tests consist of Subgroups 1, 2, 3, 7, 8, 9, 10, 11.



PIN DESCRIPTION			
Pin No.	Name	I/O	Description
1	VCC		+5 V Power Supply.
21	VSS		Ground.
5, 6	X1, X2	O, I	(Crystal). X1 and X2 are the connections for an external crystal used to determine the frequency of the internal oscillator. The crystal should be a parallel-resonant, fundamental-mode type. An RC or LC or other reactive network may be used instead of a crystal. For driving from an external frequency source, X1 should be left open and X2 should be connected to a TTL source and a pull-up resistor.
7	FOUT	O	(Frequency Out). The FOUT output is derived from a 4-bit counter that may be programmed to divide its input by any integer value from 1 through 16 inclusive. The input to the counter is selected from any of 15 sources, including the internal scaled oscillator frequencies. FOUT may be gated on and off under software control and when off will exhibit a low impedance to ground. Control over the various FOUT options resides in the Master Mode register. After power-up, FOUT provides a frequency that is 1/16 that of the oscillator. The input source on power-up is F1.
4, 39, 36 - 34	GATE1 - GATE5	I	(Gate). The Gate inputs may be used to control the operations of individual counters by determining when counting may proceed. The same Gate input may control up to three counters. Gate pins may also be selected as count sources for any of the counters and for the FOUT divider. The active polarity for a selected Gate input is programmed at each counter. Gating function options allow level-sensitive gating or edge-initiated gating. Other gating modes are available including one that allows the Gate input to select between two counter output frequencies. All gating functions may also be disabled. The active Gate input is conditioned by an auxiliary input when the unit is operating with an external 8-bit data bus. See Data Bus description. Schmitt-trigger circuitry on the GATE inputs allows slow transition times to be used.
33 - 29	SRC1 - SRC5	I	(Source). The Source inputs provide external signals that may be counted by any of the counters. Any Source line may be routed to any or all of the counters and the FOUT divider. The active polarity for a selected SRC input is programmed at each counter. Any duty cycle waveform will be accepted as long as the minimum pulse width is at least half the period of the maximum specified counting frequency for the part. Schmitt-trigger circuitry on the SRC inputs allows slow transition times to be used.
3, 2, 40, 38, 37	OUT1 - OUT5	O	(Counter). Each 3-state OUT signal is directly associated with a corresponding individual counter. Depending on the counter configuration, the OUT signal may be a pulse, a square wave, or a complex duty cycle waveform. OUT pulse polarities are individually programmable. The output circuitry detects the counter state that would have been all bits zero in the absence of a reinitialization. That information is used to generate the selected waveform type. An optional output mode for Counters 1 and 2 overrides the normal output mode and provides a true OUT signal when the counter contents match the contents of an Alarm register.
12 - 19, 20, 22 - 28	DB0 - DB7, DB8 - DB15	I/O	(Data Bus). The 16 bidirectional Data Bus lines are used for information exchanges with the host processor. HIGH on a Data Bus line corresponds to one and LOW corresponds to zero. These lines act as inputs when WR and CS are active and as outputs when RD and CS are active. When CS is inactive, these pins are placed in a high-impedance state.  After power-up or reset, the data bus will be configured for 8-bit width and will use only DB0 through DB7. DB0 is the least significant and DB7 is the most significant bit position. The data bus may be reconfigured for 16-bit width by changing a control bit in the Master Mode register. This is accomplished by writing an 8-bit command into the low-order DB lines while holding the DB13 - DB15 lines at a logic high level. Thereafter, all 16 lines can be used, with DB0 as the least significant and DB15 as the most significant bit position.  When operating in the 8-bit data bus environment, DB8 - DB15 will never be driven active by the Am9513A. DB8 through DB12 may optionally be used as additional Gate inputs (see Figure 2). If unused, they should be held HIGH. When pulled LOW, a GATENA signal will disable the action of the corresponding counter N gating. DB13 - DB15 should be held HIGH in 8-bit bus mode whenever CS and WR are simultaneously active.
10	CS	I	(Chip Select). The active-low Chip Select input enables Read and Write operations on the data bus. When Chip Select is HIGH, the Read and Write inputs are ignored. The first Chip Select signal after power-up is used to clear the power-on reset circuitry. If Chip Select is tied to ground permanently, the power-on reset circuitry may not function. In such a configuration, the software reset command must be issued following power-up to reset the Am9513A.
11	RD	I	(Read). The active-low Read signal is conditioned by Chip Select and indicates that internal information is to be transferred to the data bus. The source will be determined by the port being addressed and, for Data Port reads, by the contents of the Data Pointer register. WR and RD should be mutually exclusive.
9	WR	I	(Write). The active-low Write signal is conditioned by Chip Select and indicates that data bus information is to be transferred to an internal location. The destination will be determined by the port being addressed and, for Data Port writes, by the contents of the Data Pointer register. WR and RD should be mutually exclusive.
8	C/D	I	(Control/Data). The Control/Data signal selects source and destination locations for Read and Write operations on the data bus. Control Write operations load the Command register and the Data Pointer. Control Read operations output the Status register. Data Read and Data Write transfers communicate with all other internal registers. Indirect addressing at the data port is controlled internally by the Data Pointer register.

Signal	Abbreviation	Type	Pins
+ 5 Volts	VCC	Power	1
Ground	VSS	Power	1
Crystal	X1, X2	O, I	2
Read	$\overline{RD}$	Input	1
Write	$\overline{WR}$	Input	1
Chip Select	$\overline{CS}$	Input	1
Control/Data	C/D	Input	1
Source N	SRC	Input	5
Gate N	GATE	Input	5
Data Bus	DB	I/O	16
Frequency Out	FOUT	Output	1
Out N	OUT	Output	5

Figure 1. Interface Signal Summary

Figure 1 summarizes the interface signals and their abbreviations for the STC.

Package Pin	Data Bus Width (MM14)	
	16 Bits	8 Bits
12	DB0	DB0
13	DB1	DB1
14	DB2	DB2
15	DB3	DB3
16	DB4	DB4
17	DB5	DB5
18	DB6	DB6
19	DB7	DB7
20	DB8	GATE 1A
22	DB9	GATE 2A
23	DB10	GATE 3A
24	DB11	GATE 4A
25	DB12	GATE 5A
26	DB13	(VIH)
27	DB14	(VIH)
28	DB15	(VIH)

Figure 2. Data Bus Assignments

**Interface Considerations**

All of the input and output signals for the Am9513A are specified with logic levels compatible with those of standard TTL circuits. In addition to providing TTL compatible voltage levels, other output conditions are specified to help configure non-standard interface circuitry. The logic level specifications take into account all worst-case combinations of the three variables that affect the logic level thresholds: ambient temperature, supply voltage and processing parameters. A change in any of these toward nominal values will improve the actual operating margins and will increase noise immunity.

Unprotected open gate inputs of high quality MOS transistors exhibit very high resistances on the order of perhaps  $10^{14}$  ohms. It is easy, therefore, in some circumstances, for charge to enter the gate node of such an input faster than it can be discharged and consequently, for the gate voltage to rise high enough to break down the oxides and destroy the transistor.

All inputs to the Am9513A include protection networks to help prevent damaging accumulations of static charge. The protection circuitry is designed to slow the transitions of incoming current surges and to provide low-impedance discharge paths for voltages beyond the normal operating levels. Note, however, that input energy levels can nonetheless be too high to be successfully absorbed. Conventional design, storage, and handling precautions should be observed so that the protection networks themselves are not overstressed.

Within the limits of normal operation, the input protection circuitry is inactive and may be modeled as a lumped series RC as shown in Figure 3(a). The functionally active input connection during normal operation is the gate of a MOS transistor. No active sources or drains are connected to the inputs so that neither transient nor steady-state currents are impressed on the driving signals other than the charging or discharging of the input capacitance and the accumulated leakage associated with the protection network and the input circuit.

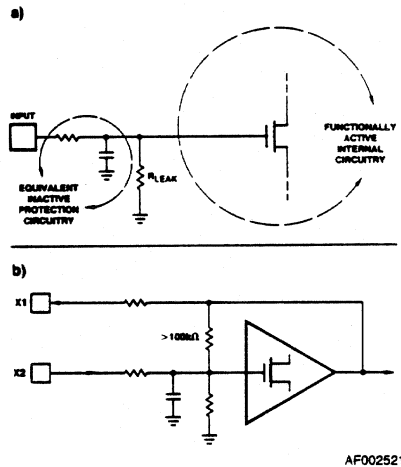

Figure 3. Input Circuitry

The only exception to the purely capacitive input case is the X2 crystal input. As shown in Figure 3(b) an internal resistor connects X1 and X2 in addition to the protection network. The resistor is a modestly high value of more than 100kohms.

Fanout from the driving circuitry into the Am9513A inputs will generally be limited by transition time considerations rather than DC current limitations when the loading is dominated by conventional MOS circuits. In an operating environment, all inputs should be terminated so they do not float and therefore will not accumulate stray static charges. Unused inputs should be tied directly to Ground or VCC, as appropriate. An input in use will have some type of logic output driving it, and termination during operation will not be a problem. Where inputs are driven from logic external to the card containing this chip, however, on-board termination should be provided to protect the chip when the board is unplugged (the input would otherwise float). A pull-up resistor or a simple inverter or gate will suffice.

2

**DETAILED DESCRIPTION**

The Am9513A System Timing Controller (STC) is a support device for processor oriented systems that is designed to enhance the available capability with respect to counting and timing operations. It provides the capability for programmable frequency synthesis, high resolution programmable duty cycle waveforms, retriggerable digital timing functions, time-of-day clocking, coincidence alarms, complex pulse generation, high resolution baud rate generation, frequency shift keying, stop-watching timing, event count accumulation, waveform analysis and many more. A variety of programmable operating modes and control features allow the Am9513A to be personalized for particular applications as well as dynamically reconfigured under program control.

The STC includes five general-purpose 16-bit counters. A variety of internal frequency sources and external pins may be selected as inputs for individual counters with software selectable active-high or active-low input polarity. Both hardware and software gating of each counter is available. Three-state outputs for each counter provide either pulses or levels. The counters can be programmed to count up or down in either binary or BCD. The accumulated count may be read without disturbing the counting process. Any of the counters may be internally concatenated to form an effective counter length of up to 80 bits.

The Am9513A block diagrams indicate the interface signals and the basic flow of information. Internal control lines and the internal data bus have been omitted. The control and data registers are all connected to a common internal 16-bit bus. The external bus may be 8- or 16-bits wide; in the 8-bit mode, the internal 16-bit information is multiplexed to the low order data bus pins DB0 through DB7.

An internal oscillator provides a convenient source of frequencies for use as counter inputs. The oscillator's frequency is controlled at the X1 and X2 interface pins by an external reactive network such as a crystal. The oscillator output is divided by the Frequency Scaler to provide several sub-frequencies. One of the scaled frequencies (or one of ten input signals) may be selected as an input to the FOUT divider and then comes out of the chip at the FOUT interface pin.

The STC is addressed by the external system as two locations: a Control port and a Data port. The Control port

provides direct access to the Status and Command registers, as well as allowing the user to update the Data Pointer register. The Data port is used to communicate with all other addressable internal locations. The Data Pointer register controls the Data port addressing.

Among the registers accessible through the Data port are the Master Mode register and five Counter Mode registers, one for each counter. The Master Mode register controls the programmable options that are not controlled by the Counter Mode registers.

Each of the five general-purpose counters is 16-bits long and is independently controlled by its Counter Mode register. Through this register, a user can software select one of 16 sources as the counter input, a variety of gating and repetition modes, up or down counting in binary or BCD and active-high or active-low input and output polarities.

Associated with each counter are a Load register and a Hold register, both accessible through the Data port. The Load register is used to automatically reload the counter to any predefined value, thus controlling the effective count period. The Hold register is used to save count values without disturbing the count process, permitting the host processor to read intermediate counts. In addition, the Hold register may be used as a second Load register to generate a number of complex output waveforms.

All five counters have the same basic control logic and control registers. Counters 1 and 2 have additional Alarm registers and comparators associated with them, plus the extra logic necessary for operating in a 24-hour time-of-day mode. For real-time operation, the time-of-day logic will accept 50Hz, 60Hz or 100Hz input frequencies.

Each general counter has a single dedicated output pin. It may be turned off when the output is not of interest or may be configured in a variety of ways to drive interrupt controllers, Darlington buffers, bus drivers, etc. The counter inputs, on the other hand, are specifically not dedicated to any given interface line. Considerable versatility is available for configuring both the input and the gating of individual counters. This not only permits dynamic reassignment of inputs under software control, but also allows multiple counters to use a single input and a single gate pin to control more than one counter. Indeed, a single pin can be the gate for one counter and, at the same time, the count source for another.

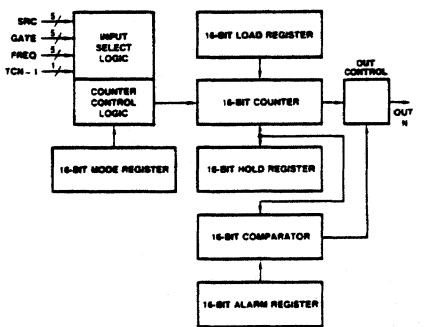

Figure 4. Counter Logic Groups 1 and 2

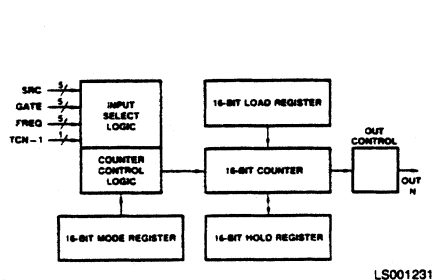
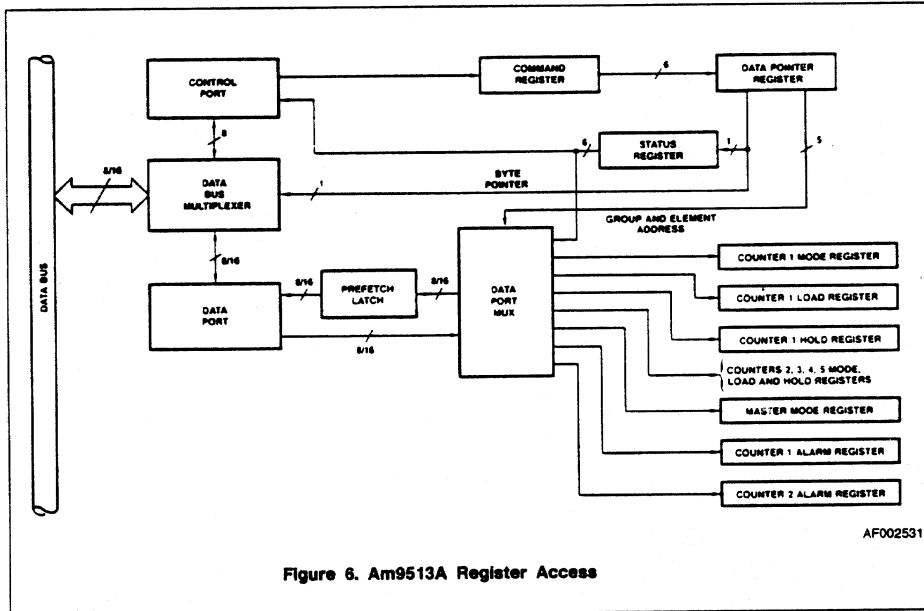

Figure 5. Counter Logic Groups 3, 4 and 5



AF002531

Figure 6. Am9513A Register Access

2

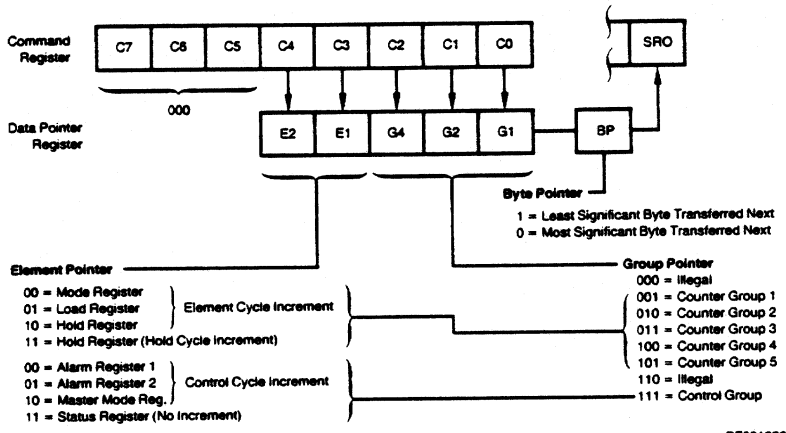

DF001890

Figure 7. Data Pointer Register



	Element Cycle			Hold Cycle
	Mode Register	Load Register	Hold Register	Hold Register
Counter 1	FF01	FF09	FF11	FF19
Counter 2	FF02	FF0A	FF12	FF1A
Counter 3	FF03	FF0B	FF13	FF1B
Counter 4	FF04	FF0C	FF14	FF1C
Counter 5	FF05	FF0D	FF15	FF1D

Master Mode Register = FF17  
 Alarm 1 Register = FF07  
 Alarm 2 Register = FF0F  
 Status Register = FF1F

- Notes:
- All codes are in hex.
  - When used with an 8-bit bus, only the two low order hex digits should be written to the command port; the "FF" prefix should be used only for a 16-bit data bus interface.

**Figure 8. Load Data Pointer Commands**

Sequencing is enabled by clearing Master Mode bit 14 (MM14) to zero. As shown in Figure 9 several types of sequencing are available depending on the data bus width being used and the initial Data Pointer value entered by command.

When E1 = 0 or E2 = 0 and G4, G2, G1 points to a Counter Group, the Data Pointer will proceed through the Element cycle. The Element field will automatically sequence through the three values 00, 01 and 10 starting with the value entered. When the transition from 10 to 00 occurs, the Group field will also be incremented by one. Note that the Element field in this case does not sequence to a value of 11. The Group field circulates only within the five Counter Group codes.

If E2, E1 = 11 and a Counter Group are selected, then only the Hold registers is sequenced. This is the Hold cycle. It allows the Hold registers to be sequentially accessed while bypassing the Mode and Load registers. The third type of sequencing is the Control cycle. If G4, G2, G1 = 111 and E2, E1 ≠ 11, the Element Pointer will be incremented through the values 00, 01 and 10, with no change to the Group Pointer.

When G4, G2, G1 = 111 and E2, E1 = 11, no incrementing takes place and only the Status register will be available through the Data port. Note that the Status register can also always be read directly through the Control port.

For all these auto-sequencing modes, if an 8-bit data bus is used, the Byte pointer will toggle after every data transfer to allow the least and most significant bytes to be transferred before the Element or Group fields are incremented.

**Prefetch Circuit**

To minimize the read access time to internal Am9513A registers, a prefetch circuit is used for all read operations through the Data port. Following each read or write operation through the Data port, the Data Pointer register is updated to point to the next register to be accessed. Immediately following this update, the new register data is transferred to a special prefetch latch at the interface pad logic. When the user performs a subsequent read of the Data port, the data bus drivers are enabled, outputting the prefetched data on the bus. Since the internal data register is accessed prior to the start of the read operation, its access time is transparent to the user. To keep the prefetched data consistent with the Data Pointer, prefetches are also performed after each write to the Data port and after execution of the "Load Data Pointer" com-

mand. The following rules should be kept in mind regarding Data port Transfers.

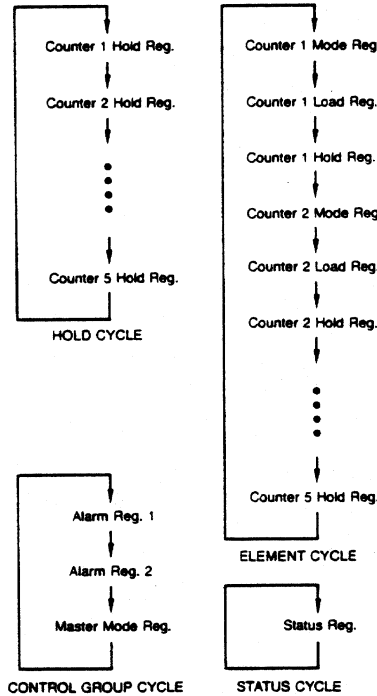

LS001240

**Figure 9. Data Pointer Sequencing**

- The Data Pointer register should always be reloaded before reading from the Data port if a command, other than "Load Data Pointer," was issued to the Am9513A following the last Data port read or write. The Data Pointer does not have to be loaded again if the first Data port transaction after a command entry is a write, since the Data port write will automatically cause a new prefetch to occur.
- Operating modes N, O, Q, R and X allow the user to save the counter contents in the Hold register by applying an active-going gate edge. If the Data Pointer register had been pointing to the Hold register in question, the prefetched value will not correspond to the new value saved in the Hold Register. To avoid reading an incorrect value, a new "Load Data Pointer" command should be issued before attempting to read the saved data. A Data port write (to another register) will also initiate a prefetch; subsequent reads will access the recently saved Hold register data. Many systems will use the "saving" gate edge to interrupt the host CPU. In systems such as this, the interrupt service routine should issue a "Load Data Pointer" command prior to reading the saved data.

**Status Register**

The 8-bit read-only Status register indicates the state of the Byte Pointer bit in the Data Pointer register and the state of the

OUT signal for each of the general counters. See Figures 10 and 17. The OUT signals reported are those internal to the chip after the polarity-select logic and just before the three-state interface buffer circuitry. Bits SR6 and SR7 may be 0 or 1.

The Status register OUT bit reflects an active-high or active-low TC output or a TC Toggled output, as programmed in the Output Control Field of the Counter Mode register. That is, it reflects the exact state of the OUT pin. When the low-impedance to Ground Output option (CM2-CM0 = 000) is selected, the Status register will reflect an active-high TC Output. When a high-impedance Output option (CM2-CM0 = 100) is selected, the Status register will reflect an active-low TC output.

For Counters 1 and 2, the OUT pin will reflect the comparator output if the comparators are enabled. The Status register bit and OUT pin are active-high if CM2 = 0 and active-low if CM2 = 1. When the high-impedance option is selected and the comparator is enabled, the status register bit will reflect an active-high comparator output. When the low-impedance to Ground option is selected and the comparator is enabled, the status register bit will reflect an active-low comparator output.

The Status register is normally accessed by reading the Control port (see Figure 6) but may also be read via the Data port as part of the Control Group.

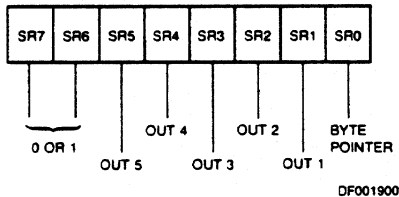

Figure 10. Status Register Bit Assignments

## DATA PORT REGISTERS

### Counter Logic Groups

As shown in Figures 4 and 5, each of the five Counter Logic Groups consists of a 16-bit general counter with associated control and output logic, a 16-bit Load register, a 16-bit Hold register and a 16-bit Mode register. In addition, Counter Groups 1 and 2 also include 16-bit Comparators and 16-bit Alarm registers. The comparator/alarm functions are controlled by the Master Mode register. The operation of the Counter Mode registers is the same for all five counters. The host CPU has both read and write access to all registers in the Counter Logic Groups through the Data port. The counter itself is never directly accessed.

### Load Register

The 16-bit read/write Load register is used to control the effective length of the general counter. Any 16-bit value may be written into the Load register. That value can then be transferred into the counter each time the Terminal Count (TC) occurs. "Terminal Count" is defined as that period of time when the counter contents would have been zero if an external value had not been transferred into the counter. Thus, the terminal count frequency can be the input frequency

divided by the value in the Load register. In all operating modes, either the Load or Hold register will be transferred into the counter when TC occurs. In cases where values are being accumulated in the counter, the Load register action can become transparent by filling the Load register with all zeros.

### Hold Register

The 16-bit read/write Hold register is dual-purpose. It can be used in the same way as the Load register, thus offering an alternate source for module definition for the counter. The Hold register may also be used to store accumulated counter values for later transfer to the host processor. This allows the count to be sampled while the counting process proceeds without interruption. Transfer of the counter contents into the Hold register is accomplished by the hardware interface in some operating modes or by software commands at any time.

### Counter Mode Register

The 16-bit read/write Counter Mode register controls the gating, counting, output and source select functions within each Counter Logic Group. The "Counter Mode Control Options" section of this document describes the detailed control options available. Figure 16 shows the bit assignments for the Counter Mode registers.

### Alarm Registers and Comparators

Added functions are available in the Counter Logic Groups for Counters 1 and 2 (see Figure 4). Each contains a 16-bit Alarm register and a 16-bit Comparator. When the value in the counter reaches the value in the Alarm register, the Comparator output will go true. The Master Mode register contains control bits to individually enable/disable the comparators. When enabled, the comparator output appears on the OUT pin of the associated counter in place of the normal counter output. The output will remain true as long as the comparison is true, that is, until the next input causes the count to change. The polarity of the Comparator output will be active-high if the Output Control field of the Counter Mode register is 001 or 010 and active-low if the Output Control field is 101.

2

## MASTER MODE CONTROL OPTIONS

The 16-bit Master Mode (MM) register is used to control those internal activities that are not controlled by the individual Counter Mode registers. This includes frequency control, Time-of-Day operation, comparator controls, data bus width and data pointer sequencing. Figure 11 shows the bit assignments for the Master Mode register. This section describes the use of each control field.

Master Mode register bits MM12, MM13 and MM14 can be individually set and reset using commands issued to the Command register. In addition, they can all be changed by writing directly to the Master Mode register.

After power-on reset or a Master Reset command, the Master Mode register is cleared to an all zero condition. This results in the following configuration:

- Time-of-Day disabled
- Both Comparators disabled
- FOUT Source is frequency F1
- FOUT Divider set for divide-by-16
- FOUT gated on
- Data Bus 8 bits wide
- Data Pointer Sequencing enabled
- Frequency Scaler divides in binary

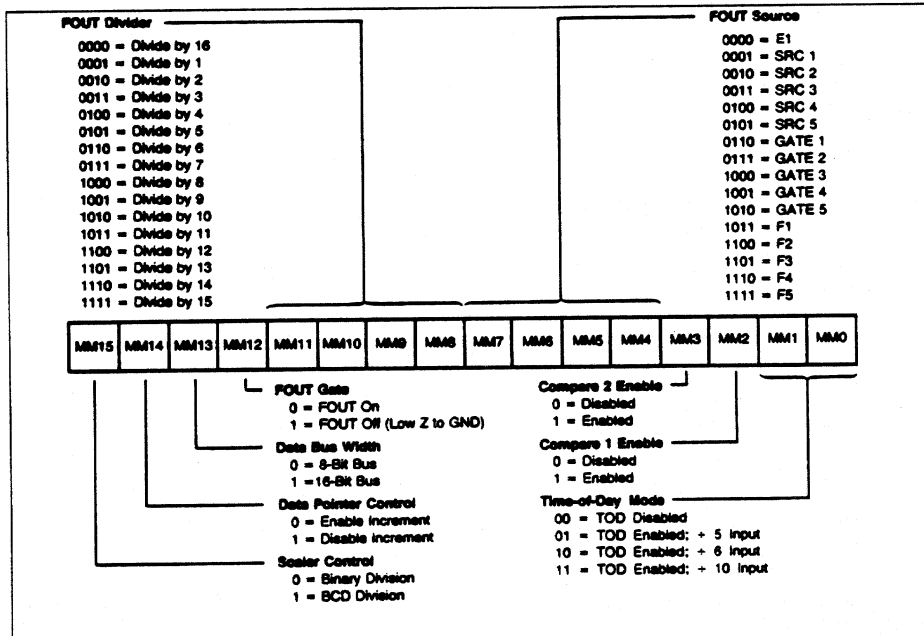

DF001913

Figure 11. Master Mode Register Bit Assignments

**Time-of-Day**

Bits MM0 and MM1 of the Master Mode register specify the Time-of-Day (TOD) options. When MM0 = 0 and MM1 = 0, the special logic used to implement TOD is disabled, and Counters 1 and 2 will operate in exactly the same way as Counters 3, 4 and 5. When MM0 = 1 or MM1 = 1, additional counter decoding and control logic is enabled on Counters 1 and 2, which causes their decades to turn over at the counts that generate appropriate 24-hour TOD accumulations. For additional information, see the Time-of-Day chapter in the 9513A System timing controller technical manual.

**Comparator Enable**

Bits MM2 and MM3 control the Comparators associated with Counters 1 and 2. When a Comparator is enabled, its output is substituted for the normal counter output on the associated OUT1 or OUT2 pin. The comparator output will be active-high if the output control field of the Counter Mode register is 001 or 010 and active-low for a code of 101. Once the compare output is true, it will remain so until the count changes and the comparison therefore goes false.

The two Comparators can always be used individually in any operating mode. One special case occurs when the Time-of-Day option is revoked and both Comparators are enabled. The operation of Comparator 2 will then be conditioned by Comparator 1 so that a full 32-bit compare must be true in order to generate a true signal on OUT2. OUT1 will continue, as usual, to reflect the state of the 16-bit comparison between Alarm 1 and Counter 1.

**FOUT Source**

Master Mode bits MM4 through MM7 specify the source input for the FOUT divider. Fifteen inputs are available for selection, and they include the five Source pins, the five Gate pins and the five internal frequencies derived from the oscillator. The 16th combination of the four control bits (all zeros) is used to assure that an active frequency is available at the input to the FOUT divider following reset.

**FOUT Divider**

Bits MM8 through MM11 specify the dividing ratio for the FOUT Divider. The FOUT source (selected by bits MM4 through MM7) is divided by an integer value between 1 and 16, inclusive, and is then passed to the FOUT output buffer. After power-on or reset, the FOUT divider is set to divide-by-16.

**FOUT Gate**

Master Mode bit MM12 provides a software gating capability for the FOUT signal. When MM12 = 1, FOUT is off and in a low-impedance state to ground. MM12 may be set or cleared in conjunction with the loading of the other bits in the Master Mode register; alternatively, there are commands that allow MM12 to be individually set or cleared directly without changing any other Master Mode bits. After power-up or reset, FOUT is gated on.

When changing the FOUT divider ratio or FOUT source, transient pulses as short as half the period of the FOUT source may appear on the FOUT pin. Turning the FOUT gate on or off can also generate a transient. This should be considered when using FOUT as a system clock source.

**Bus Width**

Bit MM13 controls the multiplexer at the data bus interface in order to configure the part for an 8-bit or 16-bit external bus. The internal bus is always 16-bits wide. When MM13 = 1, 16-bit data is transferred directly between the internal bus and all 16 of the external bus lines. In this configuration, the Byte Pointer bit in the Data Pointer register remains set at all times. When MM13 = 0, 16-bit internal data is transferred a byte at a time to and from the eight low-order external data bus lines. The Byte Pointer bit toggles with each byte transfer in this mode.

When the Am9513A is set to operate with an 8-bit data bus width, pins DB8 through DB15 are not used for the data bus and are available for other functions. Pins DB13 through DB15 should be tied high. Pins DB8 through DB12 are used as auxiliary gating inputs and are labeled GATE1A through GATE5A respectively. The auxiliary gate pin, GATENA, is logically ANDed with the gate input to Counter N, as shown in Figure 12. The output of the AND gate is then used as the gating signal for Counter N.

**Data Pointer Sequencing**

Bit MM14 controls the Data Pointer logic to enable or disable the automatic sequencing functions. When MM14 = 1, the contents of the Data Pointer can be changed only directly by entering a command. When MM14 = 0, several types of automatic sequencing of the Data Pointer are available. These are described in the Data Pointer register section of this document.

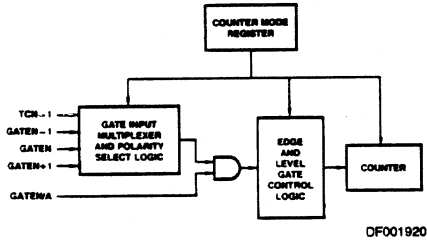

Figure 12. Gating Control

Thus, the host processor, by controlling MM14, may repetitively read/write a single internal location, or may sequentially read/write groups of locations. Bit MM14 can be loaded by writing to the Master Mode register or can be set or cleared by software command.

**Scaler Ratios**

Master Mode bit MM15 controls the counting configuration of the Frequency Scaler counter. When MM15 = 0, the Scaler divides the oscillator frequency in binary steps so that each subfrequency is 1/16 of the preceding frequency. When MM15 = 1, the Scaler divides in BCD steps so that adjacent frequencies are related by ratios of 10 instead of 16 (see Figure 13).

2

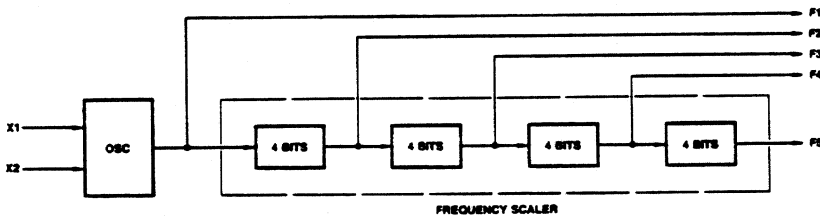

AF002541

Frequency	BCD Scaling MM15 = 1	Binary Scaling MM15 = 0
F1	OSC	OSC
F2	F1 ÷ 10	F1 ÷ 16
F3	F1 ÷ 100	F1 ÷ 256
F4	F1 ÷ 1,000	F1 ÷ 4,096
F5	F1 ÷ 10,000	F1 ÷ 65,536

Figure 13. Frequency Scaler Ratios

Counter Mode	A	B	C	D	E	F	G	H	I	J	K	L
Special Gate (CM7)	0	0	0	0	0	0	0	0	0	0	0	0
Reload Source (CM6)	0	0	0	0	0	0	1	1	1	1	1	1
Repetition (CM5)	0	0	0	1	1	1	0	0	0	1	1	1
Gate Control (CM15–CM13)	000	LEVEL	EDGE	000	LEVEL	EDGE	000	LEVEL	EDGE	000	LEVEL	EDGE
Count to TC once, then disarm	X	X	X									
Count to TC twice, then disarm							X	X	X			
Count to TC repeatedly without disarming				X	X	X				X	X	X
Gate input does not gate counter input	X			X			X			X		
Count only during active gate level		X			X			X			X	
Start count on active gate edge and stop count on next TC			X			X						
Start count on active gate edge and stop count on second TC									X			X
No hardware retriggering	X	X	X	X	X	X	X	X	X	X	X	X
Reload counter from Load register on TC	X	X	X	X	X	X						
Reload counter on each TC, alternating reload source between Load and Hold registers							X	X	X	X	X	X
Transfer Load register into counter on each TC that gate is LOW, transfer Hold register into counter on each TC that gate is HIGH.												
On active gate edge transfer counter into Hold register and then reload counter from Load register												
Counter Mode	M	N	O	P	Q	R	S	T	U	V	W	X
Special Gate (CM7)	1	1	1	1	1	1	1	1	1	1	1	1
Reload Source (CM6)	0	0	0	0	0	0	1	1	1	1	1	1
Repetition (CM5)	0	0	0	1	1	1	0	0	0	1	1	1
Gate Control (CM15–CM13)	000	LEVEL	EDGE	000	LEVEL	EDGE	000	LEVEL	EDGE	000	LEVEL	EDGE
Count to TC once, then disarm		X	X									
Count to TC twice, then disarm							X					
Count to TC repeatedly without disarming					X	X				X		X
Gate input does not gate counter input							X			X		
Count only during active gate level		X			X							
Start count on active gate edge and stop count on next TC			X			X						X
Start count on active gate edge and stop count on second TC												
No hardware retriggering							X			X		X
Reload counter from Load register on TC		X	X		X	X						X
Reload counter on each TC, alternating reload source between Load and Hold registers.												
Transfer Load register into counter on each TC that gate is LOW, transfer Hold register into counter on each TC that gate is HIGH.							X			X		
On active gate edge transfer counter into Hold register and then reload counter from Load register		X	X		X	X						
On active gate edge transfer counter into Hold register, but counting continues												X

Notes: 1. Counter modes M, P, T, U and W are reserved and should not be used.  
 2. Mode X is available for Am9513A only.

Figure 14. Counter Mode Operating Summary

**COUNTER MODE DESCRIPTIONS**

Counter Mode register bits CM15–CM13 and CM7–CM5 select the operating mode for each counter (see Figure 14). To simplify references to a particular mode, each mode is assigned a letter from A through X. Representative waveforms for the counter modes are illustrated in Figures 15a through 15v. (Because the letter suffix in the figure number is keyed to the mode, Figures 15m, 15p, 15t, 15u and 15w do not exist.) The figures assume down counting on rising source edges. Those modes which automatically disarm the counter (CM5 = 0) are shown with the WR plus entering the required ARM command; for modes which count repetitively (CM5 = 1),

the ARM command is omitted. The retriggering modes (N, O, Q and R) are shown with one retrigger operation. Both a TC output waveform and a TC Toggled output waveform are shown for each mode. The symbols L and H are used to represent count values equal to the Load and Hold register contents, respectively. The symbols K and N represent arbitrary count values. For each mode, the required bit pattern in the Counter Mode register is shown; "don't care" bits are marked "X." These figures are designed to clarify the mode descriptions; the Am9513A Electrical Specification should be used as the authoritative reference for timing relationships between signals.

To keep the following mode descriptions concise and to the point, the phrase "source edges" is used to refer to active-going source edges only, not to inactive-going edges. Similarly, the phrase "gate edges" refers only to active-going gate edges. Also, again to avoid verbosity and euphuism, the descriptions of some modes state that a counter is stopped or disarmed "on a TC, inhibiting further counting." As is fully explained in the TC section of this document, for these modes the counter is actually stopped or disarmed following the active-going source edge which drives the counter out of TC. In other words, since a counter in the TC state always counts, irrespective of its gating or arming status, the stopping or disarming of the count sequence is delayed until TC is terminated.

**MODE A**

**Software-Triggered Strobe with No Hardware Gating**

CM15	CM14	CM13	CM12	CM11	CM10	CM9	CM8
0	0	0	X	X	X	X	X

CM7	CM6	CM5	CM4	CM3	CM2	CM1	CM0
0	0	0	X	X	X	X	X

Mode A, shown in Figure 15a, is one of the simplest operating modes. The counter will be available for counting source edges when it is issued an ARM command. On each TC, the counter will reload from the Load register and automatically disarm itself, inhibiting further counting. Counting will resume when a new ARM command is issued.

**MODE B**

**Software-Triggered Strobe with Level Gating**

CM15	CM14	CM13	CM12	CM11	CM10	CM9	CM8
LEVEL			X	X	X	X	X

CM7	CM6	CM5	CM4	CM3	CM2	CM1	CM0
0	0	0	X	X	X	X	X

Mode B, shown in Figure 15b, is identical to Mode A except that source edges are counted only when the assigned Gate is active. The counter must be armed before counting can occur. Once armed, the counter will count all source edges which occur while the Gate is active and disregard those edges which occur while the Gate is inactive. This permits the Gate to turn the count process on and off. On each TC the counter will reload from the Load register and automatically disarm itself, inhibiting further counting until a new ARM command is issued.

**2**

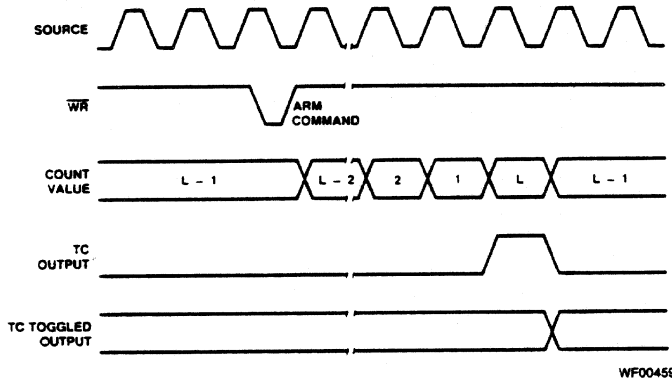

WF004590

Figure 15a. Mode A Waveforms

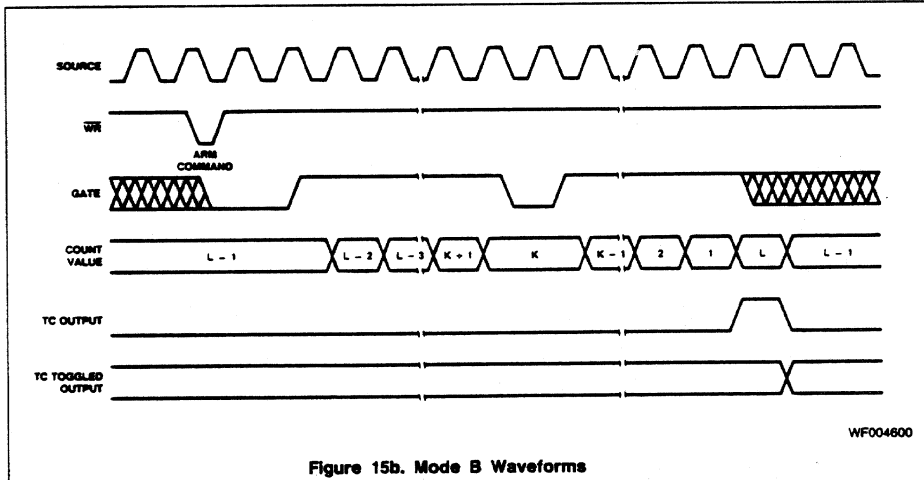

WF004600

Figure 15b. Mode B Waveforms

**MODE C**

**Hardware-Triggered Strobe**

CM15	CM14	CM13	CM12	CM11	CM10	CM9	CM8
EDGE			X	X	X	X	X

CM7	CM6	CM5	CM4	CM3	CM2	CM1	CM0
0	0	0	X	X	X	X	X

armed counter. The counter must be armed before application of the triggered Gate edge; Gate edges applied to a disarmed counter are disregarded. The counter will start counting on the first source edge after the triggering Gate edge and will continue counting until TC. At TC, the counter will reload from the Load register and automatically disarm itself. Counting will then remain inhibited until a new ARM command and a new Gate edge are applied in that order. Note that after application of a triggered Gate edge, the Gate input will be disregarded for the remainder of the count cycle. This differs from Mode B, where the Gate can be modulated throughout the count cycle to stop and start the counter.

Mode C, shown in Figure 15c, is identical to Mode A, except that counting will not begin until a Gate edge is applied to the

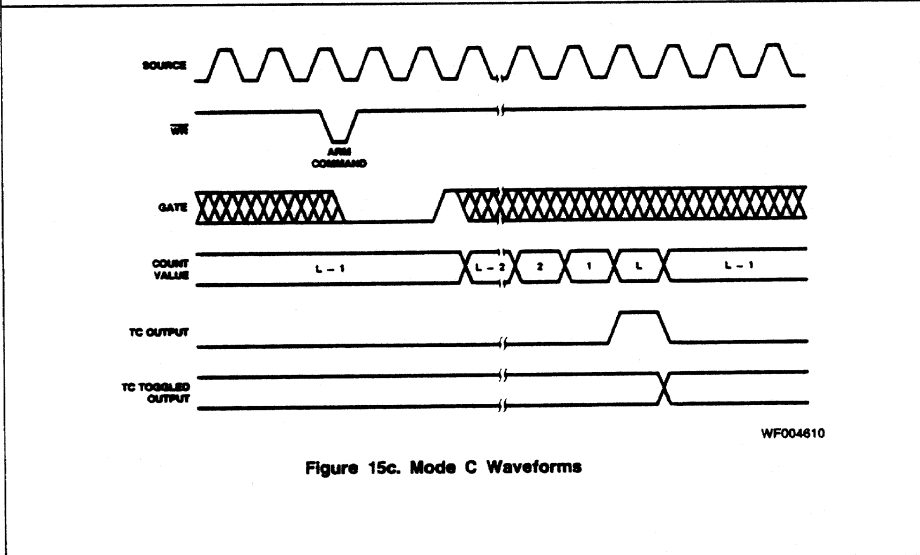

WF004610

Figure 15c. Mode C Waveforms

**MODE D**

**Rate Generator with No Hardware Gating**

CM15	CM14	CM13	CM12	CM11	CM10	CM9	CM8
0	0	0	X	X	X	X	X

CM7	CM6	CM5	CM4	CM3	CM2	CM1	CM0
0	0	1	X	X	X	X	X

Mode D, shown in Figure 15d, is typically used in frequency generation applications. In this mode, the Gate input does not affect counter operation. Once armed, the counter will count to TC repetitively. On each TC, the counter will reload itself from the Load register; hence, the Load register value determines the time between TCs. A square wave rate generator may be obtained by specifying the TC Toggled output mode in the Counter Mode register.

**MODE E**

**Rate Generator with Level Gating**

CM15	CM14	CM13	CM12	CM11	CM10	CM9	CM8
LEVEL			X	X	X	X	X

CM7	CM6	CM5	CM4	CM3	CM2	CM1	CM0
0	0	1	X	X	X	X	X

Mode E, shown in Figure 15e, is identical to Mode D, except the counter will only count those source edges which occur while the Gate input is active. This feature allows the counting process to be enabled and disabled under hardware control. A square wave rate generator may be obtained by specifying the TC Toggled output mode.

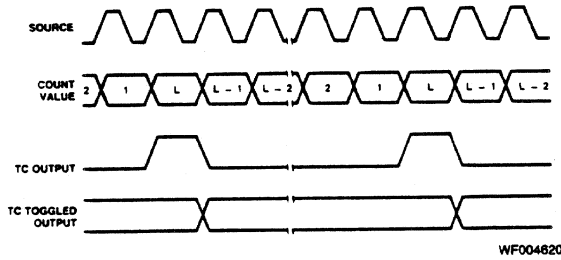

Figure 15d. Mode D Waveforms

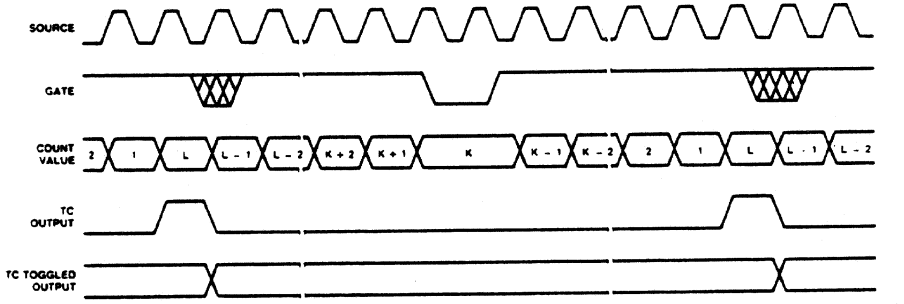

Figure 15e. Mode E Waveforms

**2**



**MODE F**

**Non-Retriggerable One-Shot**

CM15	CM14	CM13	CM12	CM11	CM10	CM9	CM8
EDGE			X	X	X	X	X

CM7	CM6	CM5	CM4	CM3	CM2	CM1	CM0
0	0	1	X	X	X	X	X

Mode F, shown in Figure 15f, provides a non-retriggerable one-shot timing function. The counter must be armed before it will function. Application of a Gate edge to the armed counter will enable counting. When the counter reaches TC, it will reload itself from the Load register. The counter will then stop counting, awaiting a new Gate edge. Note that unlike Mode C, a new ARM command is not needed after TC, only a new Gate edge. After application of a triggering Gate edge, the Gate input is disregarded until TC.

**MODE G**

**Software-Triggerred Delayed Pulse One-Shot**

CM15	CM14	CM13	CM12	CM11	CM10	CM9	CM8
0	0	0	X	X	X	X	X

CM7	CM6	CM5	CM4	CM3	CM2	CM1	CM0
0	1	0	X	X	X	X	X

In Mode G, the Gate does not affect the counter's operation. Once armed, the counter will count to TC twice and then automatically disarm itself. For most applications, the counter will initially be loaded from the Load register either by a LOAD command or by the last TC of an earlier timing cycle. Upon counting to the first TC, the counter will reload itself from the Hold register. Counting will proceed until the second TC, when the counter will reload itself from the Load register and automatically disarm itself, inhibiting further counting. Counting can be resumed by issuing a new ARM command. A software-triggerred delayed pulse one-shot may be generated by specifying the TC Toggled output mode in the Counter Mode register. The initial counter contents control the delay from the ARM command until the output pulse starts. The Hold register contents control the pulse duration. Mode G is shown in Figure 15g.

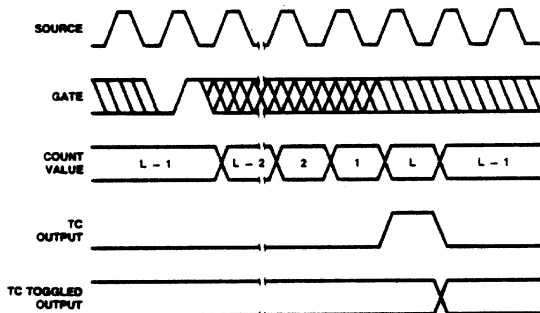

WF004640

Figure 15f. Mode F Waveforms

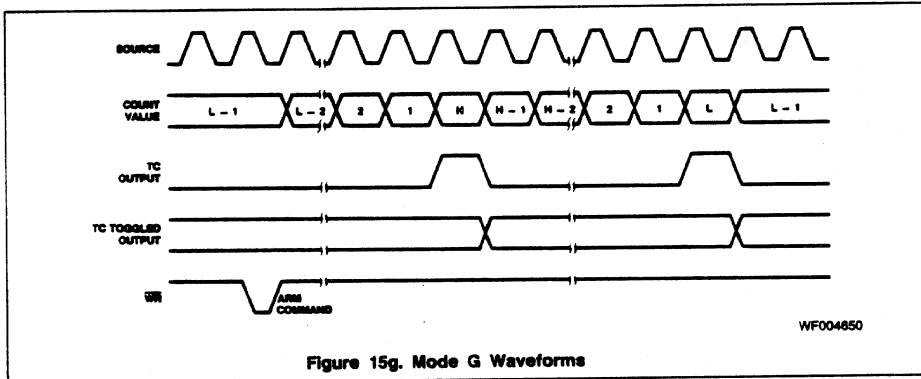

Figure 15g. Mode G Waveforms

**MODE H**

Software-Triggered Delayed Pulse One-Shot with Hardware Gating

CM15	CM14	CM13	CM12	CM11	CM10	CM9	CM8
LEVEL			X	X	X	X	X

CM7	CM6	CM5	CM4	CM3	CM2	CM1	CM0
0	1	0	X	X	X	X	X

Mode H, shown in Figure 15h, is identical to Mode G except that the Gate input is used to qualify which source edges are to be counted. The counter must be armed for counting to occur. Once armed, the counter will count all source edges that occur while the Gate is active. This permits the Gate to turn the count process on and off. As with Mode G, the counter will be reloaded from the Hold register on the first TC and reloaded from the Load register and disarmed on the second TC. This mode allows the Gate to control the extension of both the initial output delay time and the pulse width.

**MODE I**

Hardware-Triggered Delayed Pulse Strobe

CM15	CM14	CM13	CM12	CM11	CM10	CM9	CM8
EDGE			X	X	X	X	X

CM7	CM6	CM5	CM4	CM3	CM2	CM1	CM0
0	1	0	X	X	X	X	X

Mode I, shown in Figure 15i, is identical to Mode G, except that counting will not begin until a Gate edge is applied to an armed counter. The counter must be armed before application of the triggering Gate edge; Gate edges applied to a disarmed counter are disregarded. An armed counter will start counting on the first source edge after the triggering Gate edge. Counting will then proceed in the same manner as in Mode G. After the second TC, the counter will disarm itself. An ARM command and Gate edge must be issued in this order to restart counting. Note that after application of a triggering Gate edge, the Gate input will be disregarded until the second TC. This differs from Mode H, where the Gate can be modulated throughout the count cycle to stop and start the counter.

2

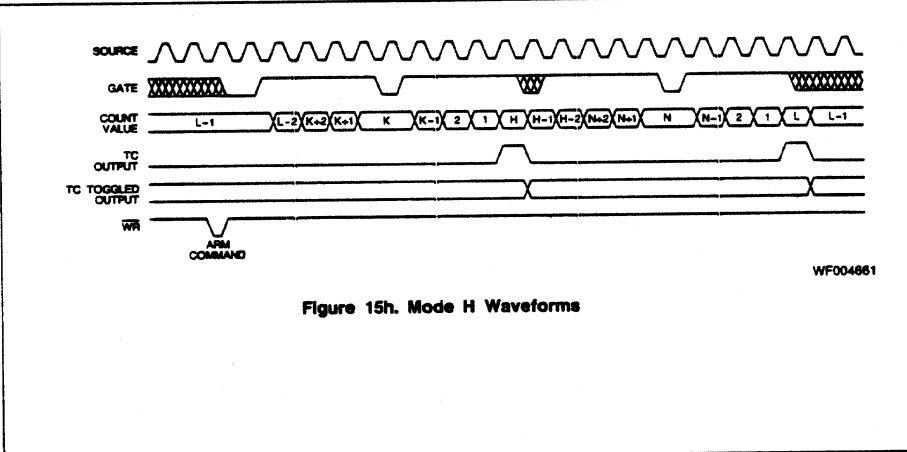

Figure 15h. Mode H Waveforms

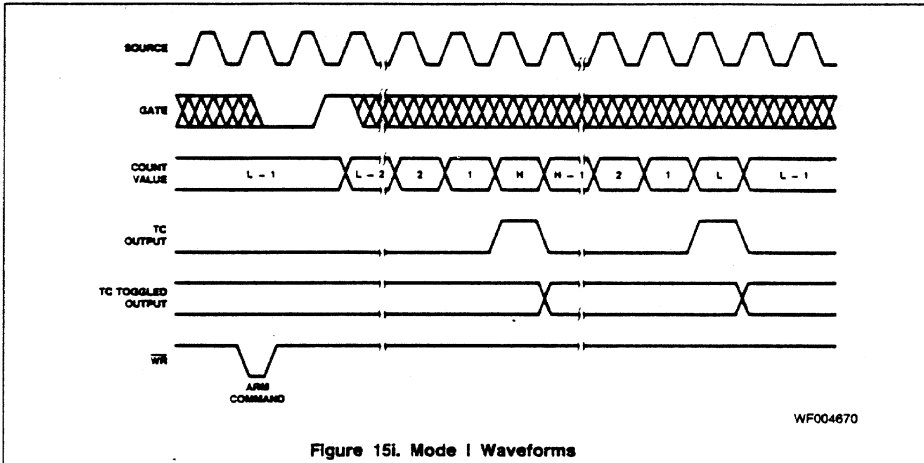

Figure 15i. Mode I Waveforms

WF004670

**MODE J**

**Variable Duty Cycle Rate Generator with No Hardware Gating**

CM15	CM14	CM13	CM12	CM11	CM10	CM9	CM8
0	0	0	X	X	X	X	X

CM7	CM6	CM5	CM4	CM3	CM2	CM1	CM0
0	1	1	X	X	X	X	X

Mode J, shown in Figure 15j, will find the greatest usage in frequency generation applications with variable duty cycle requirements. Once armed, the counter will count continuously until it is issued a DISARM command. On the first TC, the counter will be reloaded from the Hold register. Counting will then proceed until the second TC at which time the counter will be reloaded from the Load register. Counting will continue, with the reload source alternating on each TC, until a DISARM command is issued to the counter. (The third TC reloads from the Hold register, the fourth TC reloads from the Load register, etc.) A variable duty cycle output can be generated by specifying the TC Toggled output in the Counter Mode register. The Load and Hold values then directly control the output duty cycle, with high resolution available when relatively high count values are used.

**MODE K**

**Variable Duty Cycle Rate Generator with Level Gating**

CM15	CM14	CM13	CM12	CM11	CM10	CM9	CM8
LEVEL			X	X	X	X	X

CM7	CM6	CM5	CM4	CM3	CM2	CM1	CM0
0	1	1	X	X	X	X	X

Mode K, shown in Figure 15k, is identical to Mode J, except that source edges are only counted when the Gate is active. The counter must be armed for counting to occur. Once armed, the counter will count all source edges which occur while Gate is active and disregard those source edges which occur while the Gate is inactive. This permits the Gate to turn the count process on and off. As with Mode J, the reload source used will alternate on each TC, starting with the Hold register on the first TC after any ARM command. When the TC Toggled output is used, this mode allows the Gate to modulate the duty cycle of the output waveform. It can affect both the HIGH and LOW portions of the output waveform.

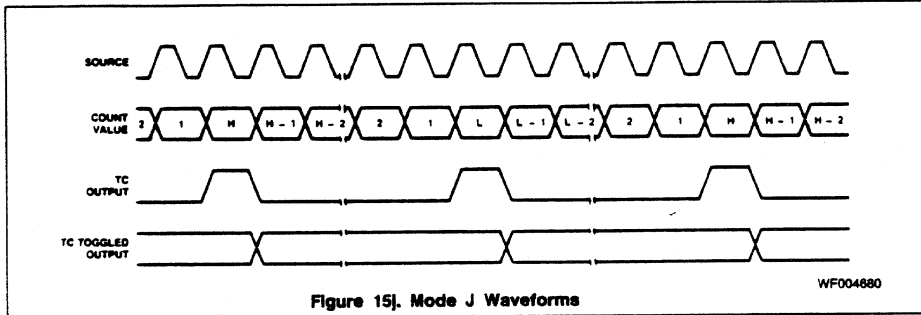

Figure 15j. Mode J Waveforms

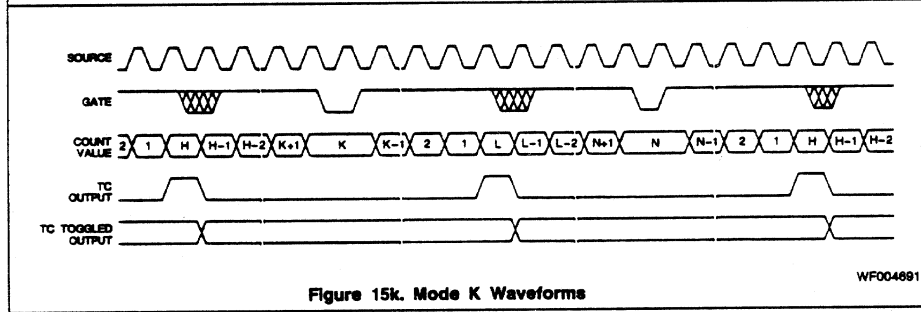

Figure 15k. Mode K Waveforms

2

**MODE L**

**Hardware-Triggered Delayed Pulse One-Shot**

CM15	CM14	CM13	CM12	CM11	CM10	CM9	CM8
EDGE			X	X	X	X	X

CM7	CM6	CM5	CM4	CM3	CM2	CM1	CM0
0	1	1	X	X	X	X	X

Mode L, shown in Figure 15j, is similar to Mode J except that counting will not begin until a Gate edge is applied to an armed counter. The counter must be armed before application of the triggering Gate edge; Gate edges applied to a disarmed counter are disregarded. The counter will start counting source edges after the triggering Gate edge, and counting will proceed until the second TC. Note that after application of a triggering Gate edge, the Gate input will be disregarded for the remainder of the count cycle. This differs from Mode K, where the gate can be modulated throughout the count cycle to stop and start the counter. On the first TC after application of the triggering Gate edge, the counter will be reloaded from the Hold register. On the second TC, the counter will be reloaded from the Load register, and counting will stop until a new gate edge is issued to the counter. Note that unlike Mode K, new Gate edges are required after every second TC to continue counting.

**MODE N**

**Software-Triggered Strobe with Level Gating and Hardware Retriggering**

CM15	CM14	CM13	CM12	CM11	CM10	CM9	CM8
LEVEL			X	X	X	X	X

CM7	CM6	CM5	CM4	CM3	CM2	CM1	CM0
1	0	0	X	X	X	X	X

Mode N, shown in Figure 15n, provides a software-triggered strobe with level gating that is also hardware retriggerable. The counter must be issued an ARM command before counting can occur. Once armed, the counter will count all source edges which occur while the gate is active and disregard those source edges which occur while the Gate is inactive. This permits the Gate to turn the count process on and off. After the issuance of the ARM command and the application of an active Gate, the counter will count to TC. Upon reaching TC, the counter will reload from the Load register and automatically disarm itself, inhibiting further counting. Counting will resume upon the issuance of a new ARM command. All active-going Gate edges issued to an armed counter will cause a retrigger operation. Upon application of the Gate edge, the counter contents will be saved in the Hold register. On the first qualified source edge after application of the retriggering gate edge, the contents of the Load register will be transferred into the counter. Counting will resume on the second qualified source edge after the retriggering Gate edge. Qualified source edges are active-going edges which occur while the Gate is active.

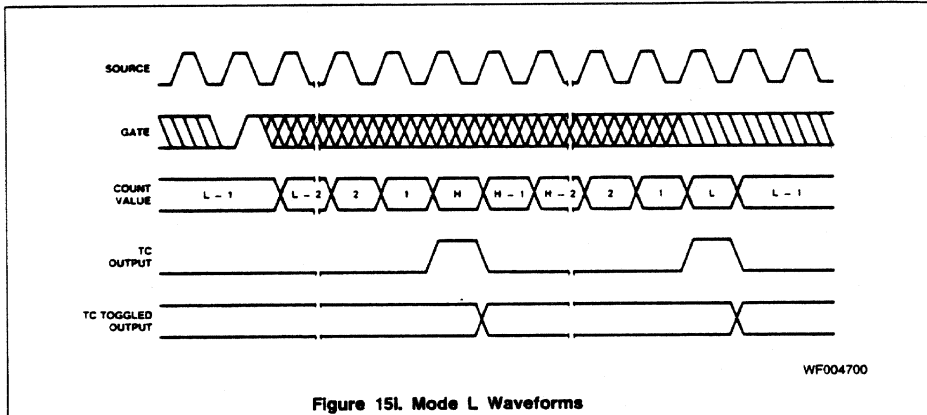

Figure 15l. Mode L Waveforms

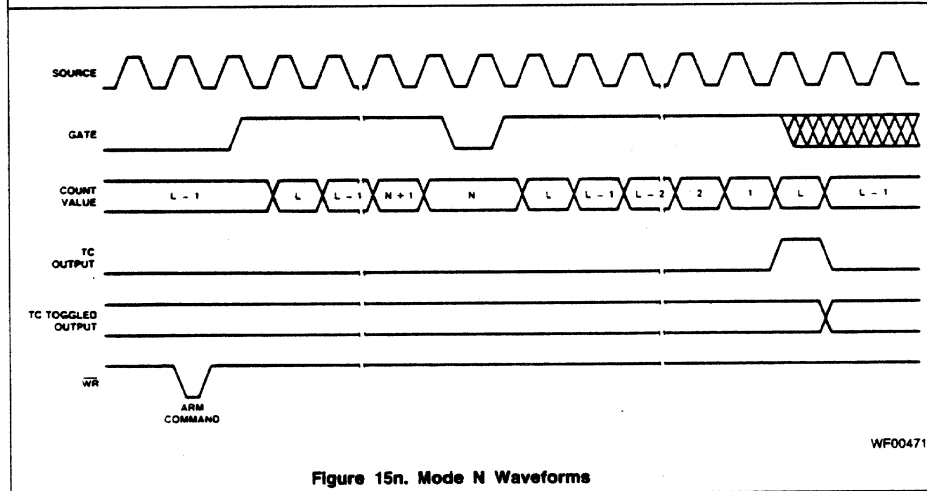

Figure 15n. Mode N Waveforms

**MODE O**

**Software-Triggered Strobe with Edge Gating and Hardware Retriggering**

CM15	CM14	CM13	CM12	CM11	CM10	CM9	CM8
EDGE			X	X	X	X	X

CM7	CM6	CM5	CM4	CM3	CM2	CM1	CM0
1	0	0	X	X	X	X	X

Mode O, shown in Figure 15o, is similar Mode N, except that counting will not begin until an active-going Gate edge is applied to an armed counter and the Gate level is not used to

modulate counting. The counter must be armed before application of the triggering Gate edge; Gate edges applied to a disarmed counter are disregarded. Irrespective of the Gate level, the counter will count all source edges after the triggering Gate edge until the first TC. On the first TC, the counter will be reloaded from the Load register and disarmed. A new ARM command and a new Gate edge must be applied in that order to initiate a new counting cycle. Unlike Modes C, F, I and L, which disregard the Gate input once counting starts, in Mode O the count process will be retriggered on all active-going Gate edges, including the first Gate edge used to start the counter. On each retriggering Gate edge, the counter contents will be transferred into the Hold register. On the first source edge after the retriggering Gate edge, the Load register contents will be transferred into the counter. Counting will resume on the second-source edge after a retrigger.

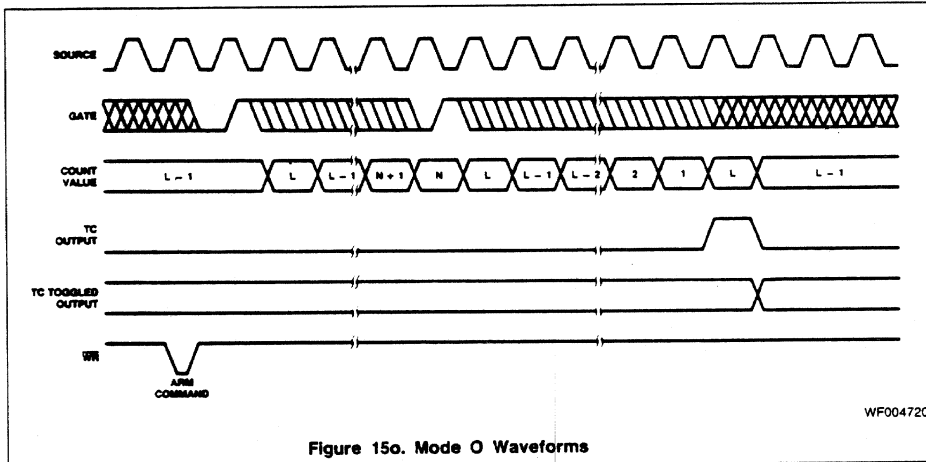

Figure 15o. Mode O Waveforms

**MODE Q**

**Rate Generator with Synchronization (Event Counter with Auto-Read/Reset)**

CM15	CM14	CM13	CM12	CM11	CM10	CM9	CM8
LEVEL			X	X	X	X	X

CM7	CM6	CM5	CM4	CM3	CM2	CM1	CM0
1	0	1	X	X	X	X	X

Mode Q, shown in Figure 15q, provides a rate generator with synchronization or an event counter with auto-read/reset. The counter must first be issued an ARM command before counting can occur. Once armed, the counter will count all source edges which occur while the Gate is active and disregard those edges which occur while the Gate is inactive. This permits the Gate to turn the count process on and off. After the issuance of an ARM command and the application of an active Gate, the counter will count to TC repetitively. On each TC, the counter will reload itself from the Load register. The counter may be retriggered at any time by presenting an active-going Gate edge to the Gate input. The retriggering Gate edge will transfer the contents of the counter into the Hold register. The first qualified source edge after the retriggering Gate edge will transfer the contents of the Load register into the Counter. Counting will resume on the second qualified source edge after the retriggering Gate edge. Qualified source edges are active-going edges which occur while the Gate is active.

**MODE R**

**Retriggerable One-Shot**

CM15	CM14	CM13	CM12	CM11	CM10	CM9	CM8
EDGE			X	X	X	X	X

CM7	CM6	CM5	CM4	CM3	CM2	CM1	CM0
1	0	1	X	X	X	X	X

Mode R, shown in Figure 15r, is similar to Mode Q, except that edge gating rather than level gating is used. In other words, rather than use the Gate level to qualify which source edges to count, Gate edges are used to start the counting operation. The counter must be armed before application of the triggering Gate edge; Gate edges applied to a disarmed counter are disregarded. After application of a Gate edge, an armed counter will count all source edges until TC, irrespective of the Gate level. On the first TC, the counter will be reloaded from the Load register and stopped. Subsequent counting will not occur until a new Gate edge is applied. All Gate edges applied to the counter, including the first used to trigger counting, initiate a retrigger operation. Upon application of a Gate edge, the counter contents are saved in the Hold register. On the first source edge after the retriggering Gate edge, the Load register contents will be transferred into the counter. Counting will resume on the second source edge after the retriggering Gate edge.

**2**

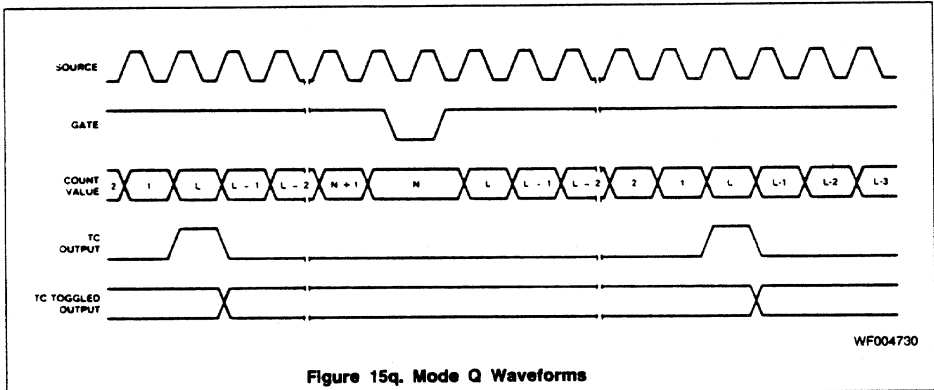

Figure 15q. Mode Q Waveforms

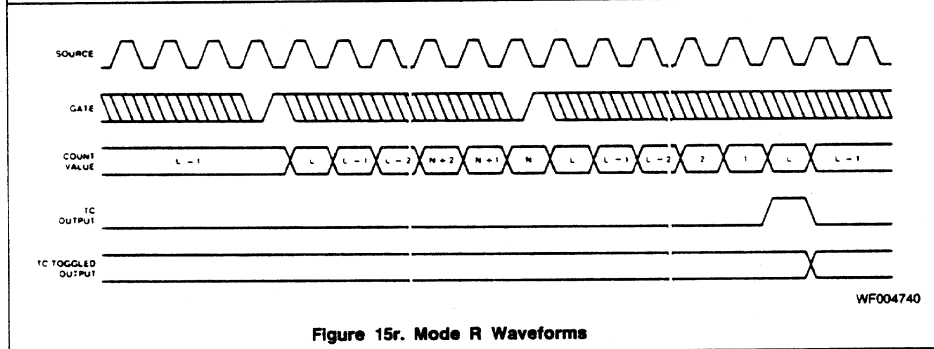

Figure 15r. Mode R Waveforms

**MODE S**

**RELOAD SOURCE**

CM15	CM14	CM13	CM12	CM11	CM10	CM9	CM8
0	0	0	X	X	X	X	X
CM7	CM6	CM5	CM4	CM3	CM2	CM1	CM0
1	1	0	X	X	X	X	X

In this mode, the reload source for LOAD commands (irrespective of whether the counter is armed or disarmed) and for TC-initiated reloads is determined by the Gate input. The Gate input in Mode S is used only to select the reload source, not to start or modulate counting. When the Gate is Low, the Load register is used; when the Gate is High, the Hold register is used. Note the Low-Load, High-Hold mnemonic convention. Once armed, the counter will count to TC twice and then disarm itself. On each TC, the counter will be reloaded from the reload source selected by the Gate. Following the second TC, an ARM command is required to start a new counting cycle. Mode S is shown in Figure 15s.

**MODE V**

**Frequency-Shift Keying**

CM15	CM14	CM13	CM12	CM11	CM10	CM9	CM8
0	0	0	X	X	X	X	X
CM7	CM6	CM5	CM4	CM3	CM2	CM1	CM0
1	1	1	X	X	X	X	X

Mode V, shown in Figure 15v, provides frequency-shift keying modulation capability. Gate operation in this mode is identical to that in Mode S. If the Gate is Low, a LOAD command or a TC-induced reload will reload the counter from the Load register. If the Gate is HIGH, LOADs and reloads will occur from the Hold register. The polarity of the Gate only selects the reload source; it does not start or modulate counting. Once armed, the counter will count repetitively to TC. On each TC, the counter will reload itself from the register determined by the polarity of the Gate. Counting will continue in this manner until a DISARM command is issued to the counter. Frequency shift keying may be obtained by specifying a TC Toggled output mode in the Counter Mode register. The switching of frequencies is achieved by modulating the Gate.

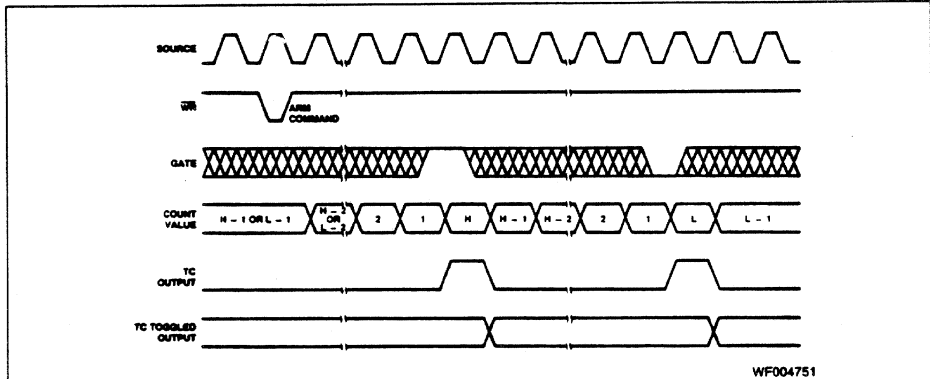

Figure 15s. Mode S Waveforms

WF004751

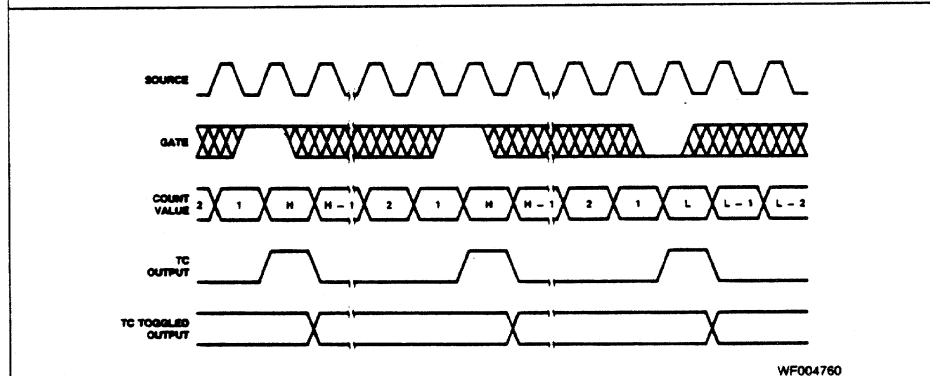

Figure 15v. Mode V Waveforms

WF004760

2



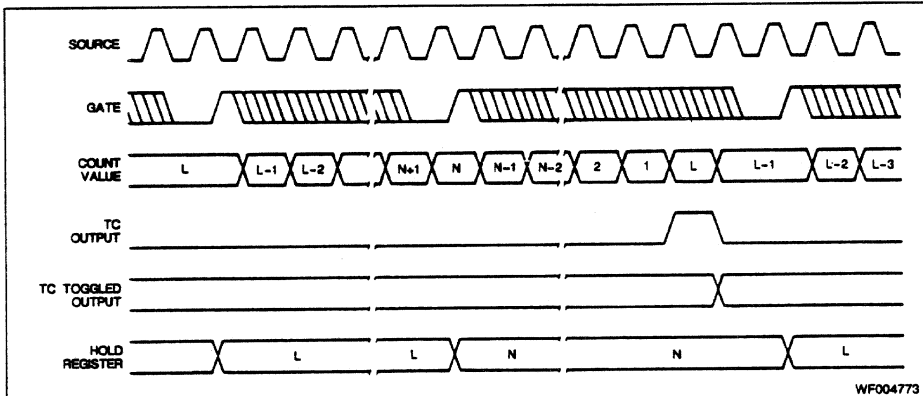

Figure 15x. Mode X Waveforms

WF004773

**MODE X**

Hardware Save (available in Am9513A only)

CM15	CM14	CM13	CM12	CM11	CM10	CM9	CM8
			X	X	X	X	X

CM7	CM6	CM5	CM4	CM3	CM2	CM1	CM0
1	1	1	X	X	X	X	X

Mode X, as shown in Figure 15x, provides a hardware sampling of the counter contents without interrupting the count. A LOAD AND ARM command or a LOAD command followed by an ARM command is required to initialize the counter. Once armed, a Gate edge starts the counting operation; Gate edges applied to a disarmed counter are disregarded. After application of the Triggering Gate edge, the counter will count all qualified source edges until the first TC, irrespective of the gate level. All gate edges applied during the counting sequence will store the current count in the Hold register, but they will not interrupt the counting sequence. On each TC, the counter will be reloaded from the Load register and stopped. Subsequent counting requires a new triggering Gate edge; counting resumes on the first source edge following the triggering Gate edge.

Note: Mode X is only available in the Am9513A devices.

**COUNTER MODE CONTROL OPTIONS**

Each Counter Logic Group includes a 18-bit Counter Mode (CM) register used to control all of the individual options available with its associated general counter. These options include output configuration, count control, count source and gating control. Figure 18 shows the bit assignments for the Counter Mode registers. This section describes the control options in detail. Note that generally each counter is independently configured and does not depend on information outside its Counter Logic Group. The Counter Mode register should be loaded only when the counter is Disarmed. Attempts to load the Counter Mode register when the counter is armed may result in erratic counter operation.

After power-on reset or a Master Reset command, the Counter Mode registers are initialized to a preset condition. The value entered is 0B00 hex and results in the following control configuration:

- Output low-impedance to ground
- Count down
- Count binary
- Count once
- Load register selected
- No retrigging
- F1 input source selected
- Positive-true input polarity
- No gating

**Output Control**

Counter mode bits CM0 through CM2 specify the output control configuration. Figure 17 shows a schematic representation of the output control logic. The OUT pin may be off (a high-impedance state), or it may be inactive with a low-impedance to ground. The three remaining valid combinations represent the active-high, active-low or TC Toggle output waveforms.

One output form available is called Terminal Count (TC) and represents the period in time that the counter reaches an equivalent value of zero. TC will occur on the next count when the counter is at 0001 for down counting, at 9999 (BCD) for BCD up counting or at FFFF (hex) for binary up counting. Figure 18 shows a Terminal Count pulse and an example context that generated it. The TC width is determined by the period of the counting source. Regardless of any gating input or whether the counter is Armed or Disarmed, the terminal count will go active for only one clock cycle. Figure 18 assumes active-high source polarity, counter armed, counter decrementing and an external reload value of K.

The counter will always be loaded from an external location when TC occurs; the user can choose the source location and the value. If a non-zero value is picked, the counter will never really attain a zero state, and TC will indicate the counter state that would have been zero had no parallel transfer occurred.

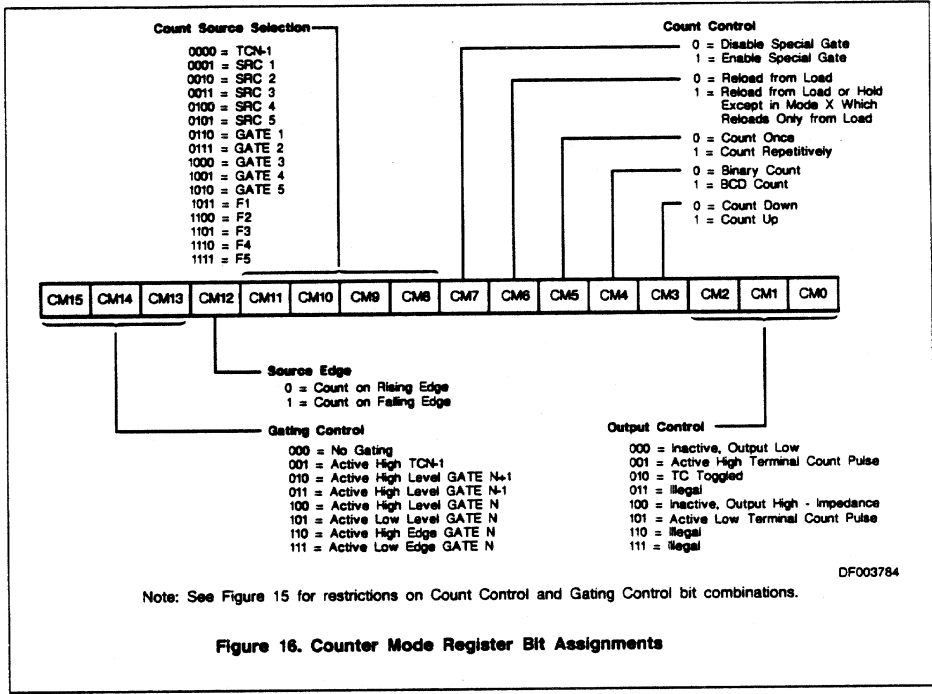

Figure 16. Counter Mode Register Bit Assignments

2

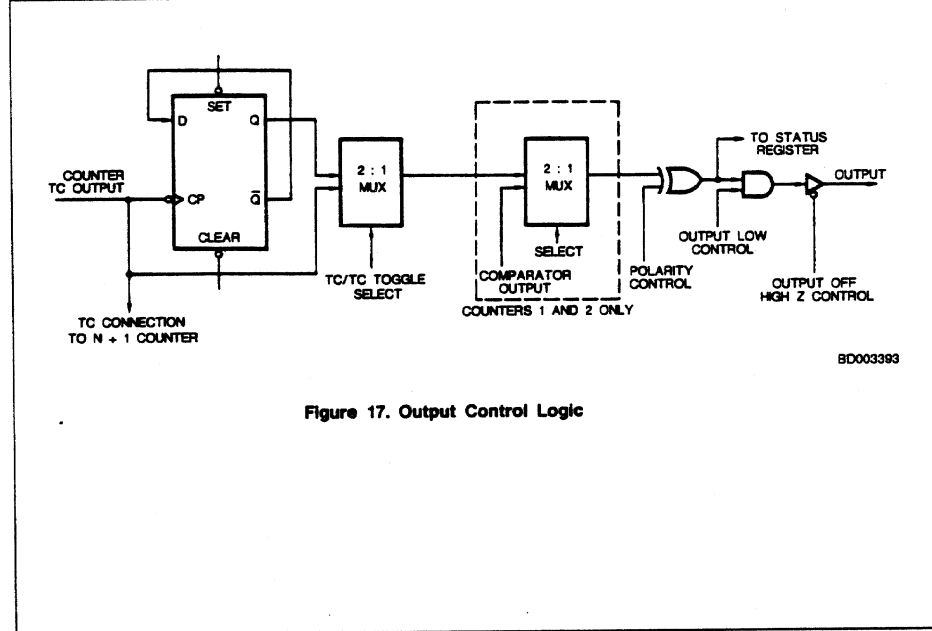

Figure 17. Output Control Logic

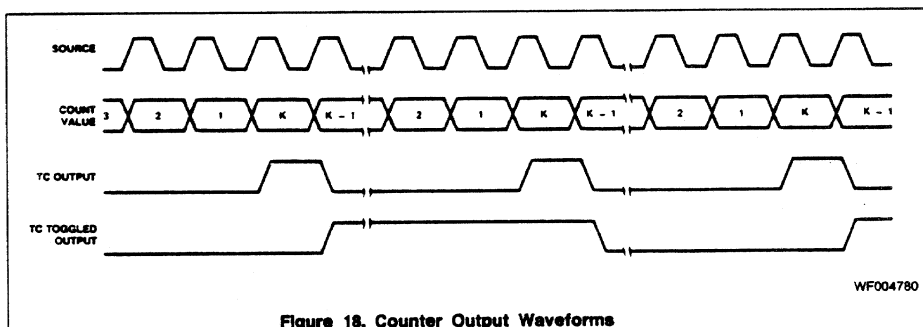

Figure 18. Counter Output Waveforms

The other output form, TC Toggled, uses the trailing edge of TC to toggle a flip-flop to generate an output level instead of a pulse. The toggle output is half the frequency of TC. The TC Toggled output will frequently be used to generate variable duty-cycle square waves in Operating Modes G through K.

In Mode L the TC Toggled output can be used to generate a one-shot function, with the delay to the start of the output pulse and the width of the output pulse separately programmable. With selection of the minimum delay to the start of the pulse, the output will toggle on the second source pulse following application of the triggering Gate edge.

Note that the TC Toggled output form contains no implication about whether the output is active-high or active-low. Unlike the TC output, which generates a transient pulse which can clearly be active-high or active-low, the TC Toggled output waveform only flips the state of the output on each TC. The sole criterion of whether the TC Toggled output is active-high or active-low is the level of the output at the start of the count cycle. This can be controlled by the Set and Clear Output commands. (See Figure 19.)

#### TC (Terminal Count)

On each Terminal Count (TC), the counter will reload itself from the Load or Hold register. TC is defined as that period of time when the counter contents would have been zero had no reload occurred. Some special conditions apply to counter operation immediately before and during TC.

1. In the clock cycle before TC, an internal signal is generated that commits the counter to go to TC on the next count, and retriggering by a hardware Gate edge (Modes N, O, Q and R) or a software LOAD or LOAD AND ARM command will not extend the time to TC. Note that the "next count" driving the counter to TC can be caused by the application of a count source edge (in level gating modes, the edge must occur while the gate is active, or it will be disregarded), by the application of a LOAD or LOAD AND ARM command (see 2 below) or by the application of a STEP command.
2. If a LOAD or LOAD AND ARM command is executed during the cycle preceding TC, the counter will immediately go to TC. If these commands are issued during TC, the TC state will immediately terminate.
3. When TC is active, the counter will always count the next source edge issued to it, even if it is disarmed or gated off during TC. This means that TC will never be active for longer than one count period and it may, in fact, be shorter if a STEP command or a LOAD or LOAD AND ARM command is applied during TC (see item 2 above). This also means that a counter that is disarmed or stopped on TC is actually disarmed/stopped immediately following TC.

This may cause count sequences different from what a user might expect. Since the counter is always reloaded at the start of TC and since it always counts at the end of TC, the counter contents following TC will differ by one from the reloaded value, irrespective of the operating mode used.

If the reloaded value was 0001 for down counting, 9999 (BCD) for BCD up counting or FFFF (hex) for binary up counting, the count at the end of TC will drive the counter into TC again regardless of whether the counter is gated off or disarmed. As long as these values are reloaded, the TC output will stay active. If a TC Toggled output is selected, it will toggle on each count. Execution of a LOAD, LOAD AND ARM or STEP command with these counter contents will act the same as application of a source pulse, causing TC to remain active and a TC Toggled output to toggle.

#### Count Control

Counter Mode bits CM3 through CM7 specify the various options available for direct control of the counting process. CM3 and CM4 operate independently of the others and control up/down and BCD/binary counting. They may be combined freely with other control bits to form many types of counting configurations. The other three bits and the Gating Control field interact in complex ways. Bit CM5 controls the repetition of the count process. When CM5 = 1, counting will proceed in the specified mode until the counter is disarmed. When CM5 = 0, the count process will proceed only until one full cycle of operation occurs. This may occur after one or two TC events. The counter is then disarmed automatically. The single or double TC requirement will depend on the state of other control bits. Note that even if the counter is automatically disarmed upon a TC, it always counts the count source edge which generates the trailing TC edge.

When TC occurs, the counter is always reloaded with a value from either the Load register or the Hold register. Bit CM6 specifies the source options for reloading the counter. When CM6 = 0, the contents of the Load register will be transferred into the counter at every occurrence of TC. When CM6 = 1, the counter reload location will be either the Load or Hold Register. The reload location in this case may be controlled externally by using a Gate pin (Modes S and V) or may alternate on each TC (Modes G through L). With alternating sources and with the TC Toggled output selected, the duty cycle of the output waveform is controlled by the relative Load and Hold values and very fine resolution of duty cycles ratios may be achieved.

Bit CM7 controls the special gating functions that allow retriggering and the selection of Load or Hold sources for counter reloading. The use and definition of CM7 will depend

on the status of the Gating Control field and bits CM5 and CM6.

#### Hardware Retriggering

Whenever hardware retriggering is enabled (Modes N, O, Q, and R), all active-going Gate edges initiate retrigger operations. On application of the Gate edge, the counter contents will be transferred to the Hold register. On the first qualified source edge after application of the retriggering Gate edge, the Load register contents will be transferred into the counter. (Qualified source edges are edges which occur while the counter is gated on and Armed.)

This means that, if level gating is used, the edge occurring on active-going gate transitions will initiate a retrigger. Similarly, when edge gating is enabled, an edge used to start the counter will also initiate a retrigger. The first count source edge applied after the Gate edge will not increment/decrement the counter but retrigger it.

If a LOAD, LOAD AND ARM, or a STEP Command occurs between the retriggering Gate edge and the first qualified source edge, it will be interpreted as a source edge and transfer the Load register contents into the counter. Thereafter, the counter will count all qualified source edges.

When some form of Gating is specified, CM7 controls hardware retriggering. In this case, when CM7 = 0, hardware retriggering does not occur; when CM7 = 1, the counter is retriggered any time an active-going Gate edge occurs. Retriggering causes the counter value to be saved in the Hold register and the Load register contents to be transferred into the counter.

When No Gating is specified, the definition of CM7 changes. In this case, when CM7 = 0, the Gate input has no effect on the counting; when CM7 = 1, the Gate input specifies the source (selecting either the Load or Hold register) used to reload the counter when TC occurs. Figure 14 shows the various available control combinations for these interrelated bits.

#### Count Source Selection

Counter Mode bits CM8 through CM12 specify the source used as input to the counter and the active edge that is counted. Bit CM12 controls the polarity for all the sources; logic zero counts rising edges and logic one counts falling edges. Bits CM8 through CM11 select 1 of 16 counting sources to route to the counter input. Five of the available inputs are internal frequencies derived from the internal oscillator (see Figure 13 for frequency assignments). Ten of the available inputs are interface pins; five are labeled SRC and five are labeled GATE.

The 16th available input is the TC output from the adjacent lower-numbered counter. (The Counter 5 TC wraps around to the Counter 1 input.) This option allows internal concatenating that permits very long counts to be accumulated. Since all five counters may be concatenated, it is possible to configure a counter that is 80-bits long on one Am9513A chip. When TCN-1 is the source, the count ripples between the connected counters. External connections can also be made, and can use the toggle bit for even longer counts. This is easily accomplished by selecting a TC Toggled output mode and wiring OUTN to one of the SRC inputs.

#### Gating Control

Counter Mode bits CM15, CM14, CM13 specify the hardware gating options. When "no gating" is selected (000), the

counter will proceed unconditionally as long as it is armed. For any other gating mode, the count process is conditioned by the specified gating configuration.

For a code of 100 in this field, counting can proceed only when the pin labeled GATEN associated with Counter N is at a logic high level. When it goes LOW, counting is simply suspended until the Gate goes HIGH again. A code of 101 performs the same function with an opposite active polarity. Codes 010 and 011 offer the same function as 100, but specify alternate input pins as Gating Sources. This allows any of three interface pins to be used as gates for a given counter. On Counter 4, for example, pin 34, pin 35 or pin 36 may be used to perform the gating function. This also allows a single Gate pin to simultaneously control up to three counters. Counters 1 and 5 are considered adjacent when using TCN-1 (001), Gate N + 1 (010) and Gate N - 1 (011) controls.

For codes of 110 or 111 in this field, counting proceeds after the specified active Gate edge until one or two TC events occur. Within this interval, the Gate input is ignored, except for the retriggering option. When repetition is selected, a cycle will be repeated as soon as another Gate edge occurs. With repetition selected, any Gate edge applied after TC goes active will start a new count cycle. Edge gating is useful when implementing a digital single-shot since the gate can serve as a convenient firing trigger.

A 001 code in this field selects the TC (not TOGGLE) output from the adjacent lower-numbered counter as the gate. This is useful for synchronous counting when adjacent counters are concatenated.

#### COMMAND DESCRIPTIONS

The command set for the Am9513A allows the host processor to customize and manage the operating modes and features for particular applications, to initialize and update both the internal data and control information, and to manipulate operating bits during operation. Commands are entered directly into the 8-bit Command register by writing into the Control port (see Figure 6).

All available commands are described in the following text. Figure 19 summarizes the command codes and includes a brief description of each function. Figure 20 shows all the unused code combinations; unused codes should not be entered into the Command register since undefined activities may occur.

Six of the command types are used for direct software control of the counting process and they each contain a 5-bit S field. In a linear-select fashion, each bit in the S field corresponds to one of five general counters (S1 = Counter 1, S2 = Counter 2, etc.). When an S bit is a one, the specified operation is performed on the counter so designated; when an S bit is a zero, no operation occurs for the corresponding counter. This type of command format has three basic advantages. It saves host software by allowing any combination of counters to be acted on by a single command. It allows simultaneous action on multiple counters where synchronization of commands is important. It allows counter-specific service routines to control individual counters without needing to be aware of the operating context of other counters.

Three of the commands use a 3-bit binary code (N4, N2, N1) to identify the affected counter (a 001 programs counter 1, etc.). Unlike the previously mentioned commands, these commands allow you to program only one counter at a time.

2

Command Code								Command Description
C7	C6	C5	C4	C3	C2	C1	C0	
0	0	0	E2	E1	G4	G2	G1	Load Data Pointer register with contents of E and G fields. (G ≠ 000, G ≠ 110)
0	0	1	S5	S4	S3	S2	S1	Arm counting for all selected counters
0	1	0	S5	S4	S3	S2	S1	Load contents of specified source into all selected counters
0	1	1	S5	S4	S3	S2	S1	Load and Arm all selected counters*
1	0	0	S5	S4	S3	S2	S1	Disarm and Save all selected counters
1	0	1	S5	S4	S3	S2	S1	Save all selected counters in Hold register
1	1	0	S5	S4	S3	S2	S1	Disarm all selected counters
1	1	1	0	1	N4	N2	N1	Set Toggle out (HIGH) for counter N (001 ≤ N ≤ 101)
1	1	1	0	0	N4	N2	N1	Clear Toggle out (LOW) for counter N (001 ≤ N ≤ 101)
1	1	1	1	0	N4	N2	N1	Step counter N (001 ≤ N ≤ 101)
1	1	1	0	1	0	0	0	Set MM14 (Disable Data Pointer Sequencing)
1	1	1	0	1	1	1	0	Set MM12 (Gate off FOUT)
1	1	1	0	1	1	1	1	Set MM13 (Enter 16-bit bus mode)
1	1	1	0	0	0	0	0	Clear MM14 (Enable Data Pointer Sequencing)
1	1	1	0	0	1	1	0	Clear MM12 (Gate on FOUT)
1	1	1	0	0	1	1	1	Clear MM13 (Enter 8-bit bus mode)
1	1	1	1	1	0	0	0	Enable Prefetch for Write operations (Am9513'A' only)
1	1	1	1	1	0	0	1	Disable Prefetch for Write operations (Am9513'A' only)
1	1	1	1	1	1	1	1	Master reset

\*Not to be used for asynchronous operations.

Figure 19. Am9513A Command Summary

C7	C6	C5	C4	C3	C2	C1	C0
1	1	1	1	0	0	0	0
1	1	1	1	0	1	1	0
1	1	1	1	0	1	1	1
0	0	0	X	X	1	1	0
0	0	0	X	X	0	0	0
*1	1	1	1	1	X	X	X

\*Unused except when XXX = 111, 001 or 000.

Figure 20. Am9513A Unused Command Codes

Arm Counters

Coding:

C7	C6	C5	C4	C3	C2	C1	C0
0	0	1	S5	S4	S3	S2	S1

Description: Any combination of counters, as specified by the S field, will be enabled for counting. A counter must be armed before counting can commence. Once armed, the counting process may be further enabled or disabled using the hardware gating facilities. This command can only arm or do nothing for a given counter; a zero in the S field does not disarm the counter.

ARM and DISARM commands can be used to gate counter operation on and off under software control. DISARM commands entered while a counter is in the TC state will not take effect until the counter leaves TC. This ensures that the counter never latches up in a TC state. (The counter may leave the TC state because of application of a count source edge, execution of a LOAD or LOAD AND ARM command, or execution of a STEP command.)

In modes which alternate reload sources (Modes G-L), the ARming operation is used as a reset for the logic which

determines which reload source to use on the upcoming TC. Following each ARM or LOAD AND ARM command, a counter in one of these modes will reload from the Hold register on the first TC and alternate reload sources thereafter (reload from the Load register on the second TC, the Hold register on the third, etc.).

Load Counters

Coding:

C7	C6	C5	C4	C3	C2	C1	C0
0	1	0	S5	S4	S3	S2	S1

Description: Any combination of counters, as specified in the S field, will be loaded with previously entered values. The source of information for each counter will be either the associated Load register or the associated Hold register, as determined by the operating configuration in the Mode register. The Load/Hold contents are not changed. This command will cause a transfer independent of any current operating configuration for the counter. It will often be used as a software retrigger or as counter initialization prior to active hardware gating.

If a LOAD or LOAD AND ARM command is executed during the cycle preceding TC, the counter will go immediately to TC. This occurs because the LOAD operation is performed by generating a pseudo-count pulse internal to the Am9513A, and the Am9513A is expecting to go into TC on the next count pulse. The reload source used to reload the counter will be the same as that which would have been used if the TC were generated by a source edge rather than by the LOAD operation.

Execution of a LOAD or LOAD AND ARM command while the counter is in TC will cause the TC to end. For Armed counters in all modes except S or V, the LOAD source used will be that to be used for the upcoming TC. (The LOADing operation will not alter the selection of reload source for the upcoming TC.) For Disarmed counters in modes except S or V, the reload sources used will be the LOAD register. For modes S or V, the reload source will be selected by the GATE input, regardless of whether the counter is Armed or Disarmed.

Special considerations apply when modes with alternating reload sources are used (Modes G – L). If a LOAD command drives the counter to TC in these modes, the reload source for the next TC will be from the opposite reload location. In other words, the LOAD-generated TC will cause the reload sources to alternate just as a TC generated by a source edge would. Note that if a second LOAD command is issued during the LOAD-generated TC (or during any other TC, for that matter), the second LOAD command will terminate the TC and cause a reload from the source designated for use with the next TC. The second LOAD will not alter the reload source for the next TC since the second LOAD does not generate a TC; reload sources alternate on TCs only, not on LOAD commands.

#### Load and Arm Counters\*

Coding:	C7	C6	C5	C4	C3	C2	C1	C0
	0	1	1	S5	S4	S3	S2	S1

Description: Any combination of counters, as specified in the S field, will be first loaded and then armed. This command is equivalent to issuing a LOAD command and then an ARM command.

A LOAD AND ARM command which drives a counter to TC generates the same sequence of operations as execution of a LOAD command and then an ARM command. In modes which disarm on TC (Modes A – C and N – O, and Modes G – I and S if the current TC is the second in the cycle), the ARM part of the LOAD AND ARM command will re-enable counting for another cycle. In modes which alternate reload sources (Modes G – L), the ARMing operation will cause the next TC to reload from the HOLD register, irrespective of which reload source the current TC used.

\*This command should not be used during asynchronous operations.

#### Disarm Counters

Coding:	C7	C6	C5	C4	C3	C2	C1	C0
	1	1	0	S5	S4	S3	S2	S1

Description: Any combination of counters, as specified by the S field, will be disabled from counting. A disarmed counter will cease all counting independent of other conditions. The only exception to this is that a counter in the TC state will always count once, in order to leave TC, before DISARming. This count may be generated by a source edge, by a LOAD or LOAD AND ARM command (the LOAD AND ARM command will negate the DISARM command) or by a STEP command. A disarmed counter may be updated using the LOAD command and may be read using the SAVE command. A count process may be resumed using an ARM command. See the ARM command description for further details.

#### Save Counters

Coding:	C7	C6	C5	C4	C3	C2	C1	C0
	1	0	1	S5	S4	S3	S2	S1

Description: Any combination of counters, as specified by S field, will have their contents transferred into their associated Hold register. The transfer takes place without interfering with any counting that may be underway. This command will overwrite any previous Hold register contents. The SAVE command is designed to allow an accumulated count to be preserved so that it can be read by the host CPU at some later time.

#### Disarm and Save Counters

Coding:	C7	C6	C5	C4	C3	C2	C1	C0
	1	0	0	S5	S4	S3	S2	S1

Description: Any combination of counters, as specified by the S field, will be disarmed, and the contents of the counter will be transferred into the associated Hold registers. This command is identical to issuing a DISARM command followed by a SAVE command.

#### Set TC Toggle Output

Coding:	C7	C6	C5	C4	C3	C2	C1	C0
	1	1	1	0	1	N4	N2	N1

(001 < N < 101)

Description: The initial output level for TC Toggle mode is set (HIGH) for counter N selected by N4, N2, N1 = 001 (Counter 1) thru 101 (Counter 5) respectively. This command conditions the TC Toggle flip-flop (see Figure 17) but does not appear at the counter output unless TC Toggle mode (CM2, CM1, CM0 = 010) is selected.

#### Clear TC Toggle Output

Coding:	C7	C6	C5	C4	C3	C2	C1	C0
	1	1	1	0	0	N4	N2	N1

(001 < N < 101)

Description: The initial output level for TC Toggle mode is Cleared (LOW) for counter N selected by N4, N2, N1 = 001 (Counter 1) thru 101 (Counter 5) respectively. This command conditions the TC Toggle flip-flop (see Figure 17) but does not appear at the counter output unless TC Toggle mode (CM2, CM1, CM0 = 010) is selected.

#### Step Counter

Coding:	C7	C6	C5	C4	C3	C2	C1	C0
	1	1	1	1	0	N4	N2	N1

(001 < N < 101)

Description: Counter N is incremented or decremented by one, depending on its operating configuration. If the Counter Mode register associated with the selected counter has its CM3 bit cleared to zero, this command will cause the counter to decrement by one. If CM3 is set to a logic high, this command will increment the counter by one. The STEP command will take effect even on a disarmed counter.

#### Load Data Pointer Register

Coding:	C7	C6	C5	C4	C3	C2	C1	C0
	0	0	0	E2	E1	G4	G2	G1

(G4, G2, G1 ≠ 000, ≠ 110)

Description: Bits in the E and G fields will be transferred into the corresponding Element and Group fields of the Data Pointer register as shown in Figure 7. The Byte Pointer bit in the Data Pointer register is set. Transfers into the Data Pointer only occur for G field values of 001, 010, 011, 100, 101 and 111. Values of 000 and 110 for G should not be used. See the "Setting the Data Pointer Register" section of this document for additional details.

#### Disable Data Pointer Sequencing

Coding:	C7	C6	C5	C4	C3	C2	C1	C0
	1	1	1	0	1	0	0	0

Description: This command sets Master Mode bit 14 without affecting other bits in the Master Mode register. MM14 controls the automatic sequencing of the Data Pointer register. Disabling the sequencing allows repetitive host processor access to a given internal location without repetitive updating of the Data Pointer. MM14 may also be controlled by loading a full word into the Master Mode register.

2

**Enable Data Pointer Sequencing**

Coding: 

C7	C6	C5	C4	C3	C2	C1	C0
1	1	1	0	0	0	0	0

Description: This command clears Master Mode bit 14 without affecting other bits in the Master Mode register. MM14 controls the automatic sequencing of the Data Pointer register. Enabling the sequencing allows sequential host processor access to several internal locations without repetitive updating of the Data Pointer. MM14 may also be controlled by loading a full word into the Master Mode register. See the "Data Pointer Register" section of this document for additional information on Data Pointer sequencing

**Enable 16-Bit Data Bus**

Coding: 

C7	C6	C5	C4	C3	C2	C1	C0
1	1	1	0	1	1	1	1

Description: This command sets Master Mode bit 13 without affecting other bits in the Master Mode register. MM13 controls the multiplexer in the data bus buffer. When MM13 is set, no multiplexing takes place and all 16 external data bus lines are used to transfer information into and out of the STC. MM13 may also be controlled by loading the full Master Mode register in parallel.

**Enable 8-Bit Data Bus**

Coding: 

C7	C6	C5	C4	C3	C2	C1	C0
1	1	1	0	0	1	1	1

Description: This command clears Master Mode bit 13 without affecting other bits in the Master Mode register. MM13 controls the multiplexer in the data bus buffer. When MM13 is cleared, the multiplexer is enabled and 16-bit internal information is transferred eight bits at a time to the eight low-order external data bus lines. MM13 may also be controlled by loading the full Master Mode register in parallel.

**Gate Off FOUT**

Coding: 

C7	C6	C5	C4	C3	C2	C1	C0
1	1	1	0	1	1	1	0

Description: This command sets Master Mode bit 12 without affecting other bits in the Master Mode register. MM12 controls the output state of the FOUT signal. When gated off, the FOUT line will exhibit a low-impedance to ground. MM12 may also be controlled by loading the full Master Mode register in parallel.

**Gate On FOUT**

Coding: 

C7	C6	C5	C4	C3	C2	C1	C0
1	1	1	0	0	1	1	0

Description: This command clears Master Mode bit 12 without affecting other bits in the Master Mode register. MM12 controls the output status of the FOUT signal. When MM12 is

cleared, FOUT will become active and will drive out the selected and divided FOUT signal. MM12 may also be controlled by loading the full Master Mode register in parallel. When FOUT is gated on or off, a transient pulse may be generated on the FOUT signal.

**Disable Prefetch for Write Operations**

Coding: 

C7	C6	C5	C4	C3	C2	C1	C0
1	1	1	1	1	0	0	1

Description: This command disables the prefetch circuitry during Write operations (if does not affect Read operations). This reduces the write recovery time and allows the user to use block move instructions for initialization of the Am9513A registers. Once prefetch is disabled for writing, an Enable Prefetch for Write or a Reset command is necessary to re-enable the prefetch circuitry for writing.

Note: This command is only available in Am9513A devices; it is an illegal command in the "non-A" Am9513 device.

**Enable Prefetch for Write Operations**

Coding: 

C7	C6	C5	C4	C3	C2	C1	C0
1	1	1	1	1	0	0	0

Description: This command re-enables the prefetch circuitry for Write operations. It is used only to terminate the Disable Prefetch Command.

Note: This command is only available in Am9513A devices; it is an illegal command in the "non-A" Am9513 device.

**Master Reset**

Coding: 

C7	C6	C5	C4	C3	C2	C1	C0
1	1	1	1	1	1	1	1

Description: The Master Reset command duplicates the action of the power-on reset circuitry. It disarms all counters, enters 0000 in the Master Mode, Load and Hold registers and enters 0B00 (hex) in the Counter Mode registers.

Following either a power-up or software reset, the LOAD command should be applied to all the counters to clear any that may be in a TC state. The Data Pointer register should also be set to a legal value, since reset does not initialize it. A complete reset operation follows.

1. Using the procedure given in the "Command Initiation" section of this document, enter the FF (hex) command to perform a software reset.
2. Using the "Command Initiation" procedure, enter the LOAD command for all counters, opcode 5F (hex).
3. Using the procedure given in the "Setting the Data Pointer Register" section of this document, set the Data Pointer to a valid code. The legal Data Pointer codes are given in Figure 8.

The Master Mode, Counter Mode, Load and Hold registers can now be initialized to the desired values.

**ABSOLUTE MAXIMUM RATINGS**

Storage Temperature ..... -65°C to +150°C  
 VCC with Respect to VSS ..... -0.5 V to +7.0 V  
 All Signal Voltages  
 with Respect to VSS ..... -0.5 V to +7.0 V  
 Power Dissipation (Package Limitation) ..... 1.5 W

*Stresses above those listed under ABSOLUTE MAXIMUM RATINGS may cause permanent device failure. Functionality at or above these limits is not implied. Exposure to absolute maximum ratings for extended periods may affect device reliability.*

**OPERATING RANGES**

Commercial (C) Devices  
 Temperature (T<sub>A</sub>) ..... 0 to +70°C  
 Supply Voltage (V<sub>CC</sub>) ..... 5 V ±5%

Industrial (I) Devices  
 Temperature (T<sub>A</sub>) ..... -40 to +85°C  
 Supply Voltage (V<sub>CC</sub>) ..... 5 V ±5%

Military (M) Devices  
 Temperature (T<sub>C</sub>) ..... -55 to +125°C  
 Supply Voltage (V<sub>CC</sub>) ..... 5 V ±5%

*Operating ranges define those limits between which the functionality of the device is guaranteed.*

**DC CHARACTERISTICS** over operating ranges unless otherwise specified.

Parameters	Description	Test Conditions	Min	Max	Units	
VIL	Input Low Voltage	All Inputs Except X2	VSS - 0.5	0.8	Volts	
		X2 Input	VSS - 0.5	0.8		
VIH	Input High Voltage	All Input Except X2	2.2 V	VCC	Volts	
		X2 Input	3.8	VCC		
VITH	Input Hysteresis (SRC and GATE inputs Only)		0.2		Volts	
VOL	Output Low Voltage	IOL = 3.2 mA		0.4	Volts	
VOH	Output High Voltage	IOH = -200 µA	2.4		Volts	
IIX	Input Load Current (Except X2)	VSS ≤ VIN ≤ VCC		±10	µA	
IIX	Input Load Current X2	VSS ≤ VIN ≤ VCC		±100	µA	
IOZ	Output Leakage Current (Except X1)	VSS + 0.4 ≤ VOUT ≤ VCC High-Impedance State		±25	µA	
ICC	VCC Supply Current (Steady State)			255	275	mA
CiN	Input Capacitance	f = 1 MHz, T <sub>A</sub> = +25°C. All pins not under test at 0 V.		10*	20*	pF
COU	Output Capacitance			15*	20*	
CI0	IN/OUT Capacitance			20*	20*	

\* Guaranteed by design.



**SWITCHING TEST INPUT/OUTPUT WAVEFORMS**

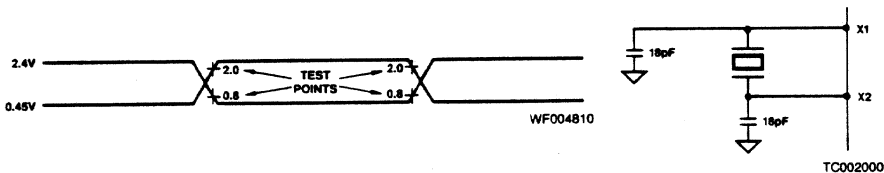

Crystal is fundamental mode parallel resonant 32 pF load capacitance less than 100 Ω ESR C<sub>0</sub> less than 100 pF.



The second and fourth letters designate the reference states of the signals named in the first and third letters respectively, using the following abbreviations.

H = HIGH  
 L = LOW  
 V = VALID  
 X = Unknown or Don't care  
 Z = High-Impedance

2. Any input transition that occurs before this minimum setup requirement will be reflected in the contents read from the status register.
3. Any input transition that occurs before this minimum setup requirement will act on the counter before the execution of the operation initiated by the write and the counter may be off by one count.
4. Any input transition that occurs after this minimum hold time is guaranteed to not influence the contents read from the status register on the current read operation.
5. Any input transition that occurs after this minimum hold time is guaranteed to be seen by the counter as occurring after the action initiated by the write operation and the counter may be off by one count.
6. This parameter applies to cases where the write operation causes a change in the output bit.
7. The enabled count source is one of F1 – F5, TCN-1 SRC1 – SRC5 or GATE1 – GATE 5, as selected in the applicable Counter Mode register. The timing diagram assumes the counter counts on rising source edges. The timing specifications are the same for falling-edge counting.
8. This parameter applies to edge gating (CM15 – CM13 = 110 or 111) and gating when both CM7 = 1 and CM15 – CM13 ≠ 000. This parameter represents the minimum GATE pulse width needed to ensure that the pulse initiates counting or counter reloading.
9. This parameter applies to both edge and level gating (CM15 – CM13 = 001 through 111 and CM7 = 0). This parameter represents the minimum setup or hold times to ensure that the Gate input is seen at the intended level on the active source edge and the counter may be off by one count.
10. This parameter assumes that the GATENA input is unused (16-bit bus mode) or is tied high. In cases where the GATENA input is used, this timing specification must be met by both the GATE and GATENA inputs.
11. Signals F1 – F5 cannot be directly monitored by the user. The phase difference between these signals will manifest itself by causing counters using two different F signals to count at different times on nominally simultaneous transitions in the F signals. F1 = X2.
12. This timing specification assumes that  $\overline{CS}$  is active whenever  $\overline{RD}$  or  $\overline{WR}$  are active.  $\overline{CS}$  may be held active indefinitely.
13. This parameter assumes X2 is driven from an external gate with a square wave.
14. This parameter assumes that the write operation is to the command register.
15. This timing specification applies to single-action commands only (e.g., LOAD, ARM, SAVE, etc.). For double-action commands such as LOAD AND ARM and DISARM AND SAVE, TWHEH minimum = 700 ns.
16. In short data write mode, TWHRL and TWHWL minimum = 1000 ns.
17. This parameter applies to the hardware retrigger/save modes N, O, Q, R, and X (CM7 = 1 and CM15 – CM13 <> 000). This parameter ensures that the gating pulse initiates a hardware retrigger/save operation.
18. This parameter applies to hardware load source select modes S and V (CM7 = 1 and CM15 – CM13 = 000). This parameter represents the minimum hold time to ensure that the GATE input selects the correct load source on the active source edge.

**SWITCHING CHARACTERISTICS** over COMMERCIAL operating ranges unless otherwise specified (Note 1)

Parameters	Description	Figure	Am9513A		Unit	
			Min	Max		
TAVRL	C/D Valid to Read Low	21	25		ns	
TAVWH	C/D Valid to Write High	21	170		ns	
TCHCH	X2 High to X2 High (X2 Period) (Note 13)	22	145		ns	
TCHCL	X2 High to X2 Low (X2 High Pulse Width) (Note 13)	22	70		ns	
TCLCH	X2 Low to X2 High (X2 Low Pulse Width) (Note 13)	22	70		ns	
TDVWH	Data In Valid to Write High	21	80		ns	
TEHEH	Count Source High to Count Source High (Source Cycle Time) (Note 7)	22	145		ns	
TEHEL TELEH	Count Source Pulse Duration (Note 7)	22	70		ns	
TEHFV	Count Source High to FOUT Valid (Note 7)	22		500	ns	
TEHGV	Count Source High to Gate Valid (Level Gating Hold Time) (Notes 7, 9, 10)	22	10		ns	
TEHRL	Count Source High to Read Low (Set-up Time) (Notes 2, 7)	21	190		ns	
TEHWH	Count Source High to Write High (Set-up Time) (Notes 3, 7)	21	-100		ns	
TEHYV	Count Source High to Out Valid (Note 7)	TC Output	22		300	ns
		Immediate or Delayed Toggle Output	22		300	
		Comparator Output	22		350	
TFN	FN High to FN + 1 Valid (Note 11)	22		75	ns	
TGVEH	Gate Valid to Count Source High (Level Gating Set-up Time) (Notes 7, 9, 10)	22	100		ns	
TGVGV	Gate Valid to Gate Valid (Gate Pulse Duration) (Notes 8, 10)	22	145		ns	
TGVWH	Gate Valid to Write High (Notes 3, 10)	21	-100		ns	
TRHAX	Read High to C/D Don't Care	21	0		ns	
TRHEH	Read High to Count Source High (Notes 4, 7)	21	0		ns	
TRHQX	Read High to Data Out Invalid	21	10		ns	
TRHQZ	Read High to Data Out at High-impedance (Data Bus Release Time)	21		85	ns	
TRHRL	Read High to Read Low (Read Recovery Time)	21	1000		ns	
TRHSH	Read High to CS High (Note 12)	21	0		ns	
TRHWL	Read High to Write Low (Read Recovery Time)	21	1000		ns	
TRLOV	Read Low to Data Out Valid	21		110	ns	
TRLQX	Read Low to Data Bus Driven (Data Bus Drive Time)	21	20		ns	
TRLRH	Read Low to Read High (Read Pulse Duration) (Note 12)	21	160		ns	
TSLRL	CS Low to Read Low (Note 12)	21	20		ns	
TSLWH	CS Low to Write High (Note 12)	21	170		ns	
TWHAX	Write High to C/D Don't Care	21	20		ns	
TWHDX	Write High to Data In Don't Care	21	20		ns	
TWHEH	Write High to Count Source High (Notes 5, 7, 14, 15)	21	550		ns	
TWHGV	Write High to Gate Valid (Notes 5, 10, 14)	21	475		ns	
TWHRL	Write High to Read Low (Write Recovery Time) (Note 16)	21	1500*		ns	
TWHSH	Write High to CS High (Note 12)	21	20		ns	
TWHWL	Write High to Write Low (Write Recovery Time) (Note 16)	21	1500*		ns	
TWHYV	Write High to Out Valid (Notes 6, 14)	21		650	ns	
TWLWH	Write Low to Write High (Write Pulse Duration) (Note 12)	21	150		ns	
TGVEH2	Gate Valid to Count Source High (Special Gate) (Notes 10, 13, 17)	22	200		ns	
TEHGV2	Count Source High to Gate Valid (Special Gate) (Notes 10, 13, 18)	22	80		ns	

**Notes:**

1. Abbreviations used for the switching parameter symbols are given as the letter T followed by four or five characters. The first and third characters represent the signal names on which the measurements start and end. Signal abbreviations used are:

A (Address) = C/D  
 C (Clock) = X2  
 D (Data In) = DB0-DB15

E (Enabled counter source input) = SRC1 - SRC5,  
 GATE1 - GATE5, F1 - F5, TCN-1

F = FOUT

G (Counter gate input) = GATE1 - GATE5, TCN-1

Q (Data Out) = DB0 - DB15

R (Read) = RD

S (Chip Select) = CS

W (Write) = WR

Y (Output) = OUT1 - OUT5

**2**

<b>SWITCHING CHARACTERISTICS</b> over <b>MILITARY</b> operating range (for SMD/DESC and APL Products, Group A, Subgroups 9, 10, 11 are tested unless otherwise noted)				
Parameter Symbol	Description	Am9513A		Unit
		Min.	Max.	
TAVRL	C/D Valid to Read Low	25		ns
TAVWH	C/D Valid to Write High	170		ns
TCHCH	X2 High to X2 High (X2 Period) (Note 13)	145		ns
TCHCL	X2 High to X2 Low (X2 High Pulse Width) (Note 13)	70		ns
TCLCH	X2 Low to X2 High (X2 Low Pulse Width) (Note 13)	70		ns
TDVWH	Data In Valid to Write High	80		ns
TEHEH	Count Source High to Count Source High (Source Cycle Time) (Note 7)	145		ns
TEHEL	Count Source Pulse Duration (Note 7)	70		ns
TEHFEV	Count Source High to FOUT Valid (Note 7)		500	ns
TEHGV	Count Source High to Gate Valid (Level Gating Hold Time) (Notes 7, 9, 10)	10		ns
TEHRL	Count Source High to Read Low (Set-up Time) (Notes 2, 7)	190		ns
TEHWH	Count Source High to Write High (Set-up Time) (Notes 3, 7)	-100		ns
TEHYV	Count Source High to Out Valid (Note 7)	TC Output	300	ns
		Immediate or Delayed Toggle Output	300	
		Comparator Output	350	
TFN	FN High to FN + 1 Valid (Note 11)		75	ns
TGVEH	Gate Valid to Count Source High (Level Gating Set-up Time) (Notes 7, 9, 10)	100		ns
TGVG	Gate Valid to Gate Valid (Gate Pulse Duration) (Notes 8, 10)	145		ns
TGVWH	Gate Valid to Write High (Notes 3, 10)	-100		ns
TRHAX	Read High to C/D Don't Care	0		ns
TRHEH	Read High to Count Source High (Notes 4, 7)	0		ns
TRHQX	Read High to Data Out Invalid	10		ns
TRHQZ	Read High to Data Out at High-Impedance (Data Bus Release Time)		85	ns
TRHRL	Read High to Read Low (Read Recovery Time)	1000		ns
TRHSH	Read High to CS High (Note 12)	0		ns
TRHWL	Read High to Write Low (Read Recovery Time)	1000		ns
TRLQV	Read Low to Data Out Valid		110	ns
TRLQX	Read Low to Data Bus Driven (Data Bus Drive Time)	20		ns
TRLRH	Read Low to Read High (Read Pulse Duration) (Note 12)	160		ns
TSLRL	CS Low to Read Low (Note 12)	20		ns
TSLWH	CS Low to Write High (Note 12)	170		ns
TWHAX	Write High to C/D Don't Care	20		ns
TWHDX	Write High to Data In Don't Care	20		ns
TWHEH	Write High to Count Source High (Notes 5, 7, 14, 15)	550		ns
TWHGV	Write High to Gate Valid (Notes 5, 10, 14)	475		ns
TWHRL	Write High to Read Low (Write Recovery Time) (Note 16)	1500		ns
TWHSH	Write High to CS High (Note 12)	20		ns
TWHWL	Write High to Write Low (Write Recovery Time) (Note 16)	1500		ns
TWHYV	Write High to Out Valid (Notes 6, 14)		650	ns
TWLWH	Write Low to Write High (Write Pulse Duration) (Note 12)	150		ns
TGVEH2	Gate Valid to Count Source High (Special Gate) (Notes 10, 13, 17)	200		ns
TEHGV2	Count Source High to Gate Valid (Special Gate) (Notes 10, 13, 18)	80		ns

**Notes:**

1. Abbreviations used for the switching parameter symbols are given as the letter T followed by four or five characters. The first and third characters represent the signal names on which the measurements start and end. Signal abbreviations used are:

A (Address) = C/D  
C (Clock) = X2  
D (Data In) = DB0 - DB15  
E (Enabled counter source input) = SRC1 - SRC5, GATE1 - GATE5, F1 - F5, TCN-1  
F = FOUT  
G (Counter gate input) = GATE1 - GATE5, TCN-1  
Q (Data Out) = DB0 - DB15  
R (Read) = RD  
S (Chip Select) = CS  
W (Write) = WR  
Y (Output) = OUT1 - OUT5

The second and fourth letters designate the reference states of the signals named in the first and third letters respectively, using the following abbreviations.

- H = HIGH
- L = LOW
- V = VALID
- X = Unknown or Don't care
- Z = High-Impedance

2. Any input transition that occurs before this minimum setup requirement will be reflected in the contents read from the status register.
3. Any input transition that occurs before this minimum setup requirement will act on the counter before the execution of the operation initiated by the write and the counter may be off by one count.
4. Any input transition that occurs after this minimum hold time is guaranteed to not influence the contents read from the status register on the current read operation.
5. Any input transition that occurs after this minimum hold time is guaranteed to be seen by the counter as occurring after the action initiated by the write operation and the counter may be off by one count.
6. This parameter applies to cases where the write operation causes a change in the output bit.
7. The enabled count source is one of F1 – F5, TCN-1 SRC1 – SRC5 or GATE1 – GATE 5, as selected in the applicable Counter Mode register. The timing diagram assumes the counter counts on rising source edges. The timing specifications are the same for falling-edge counting.
8. This parameter applies to edge gating (CM15 – CM13 = 110 or 111) and gating when both CM7 = 1 and CM15 – CM13 ≠ 000. This parameter represents the minimum GATE pulse width needed to ensure that the pulse initiates counting or counter reloading.
9. This parameter applies to both edge and level gating (CM15 – CM13 = 001 through 111 and CM7 = 0). This pa-

parameter represents the minimum setup or hold times to ensure that the Gate input is seen at the intended level on the active source edge and the counter may be off by one count.

10. This parameter assumes that the GATENA input is unused (16-bit bus mode) or is tied high. In cases where the GATENA input is used, this timing specification must be met by both the GATE and GATENA inputs.
11. Signals F1 – F5 cannot be directly monitored by the user. The phase difference between these signals will manifest itself by causing counters using two different F signals to count at different times on nominally simultaneous transitions in the F signals. F1 = X2.
12. This timing specification assumes that  $\overline{CS}$  is active whenever RD or WR are active.  $\overline{CS}$  may be held active indefinitely.
13. This parameter assumes X2 is driven from an external gate with a square wave.
14. This parameter assumes that the write operation is to the command register.
15. This timing specification applies to single-action commands only (e.g., LOAD, ARM, SAVE, etc.). For double-action commands such as LOAD AND ARM and DISARM AND SAVE, TWHEH minimum = 700 ns.
16. In short data write mode, TWHRL and TWHWL minimum = 1000 ns.
17. This parameter applies to the hardware retrigger/save modes N, O, Q, R, and X (CM7 = 1 and CM15 – CM13 < > 000). This parameter ensures that the gating pulse initiates a hardware retrigger/save operation.
18. This parameter applies to hardware load source select modes S and V (CM7 = 1 and CM15 – CM13 = 000). This parameter represents the minimum hold time to ensure that the GATE input selects the correct load source on the active source edge.

2

### SWITCHING TEST CIRCUIT

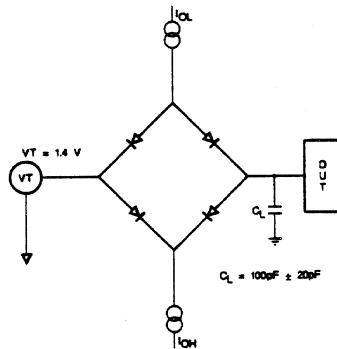

TC003853

This test circuit is the dynamic load of a Teradyne J941.

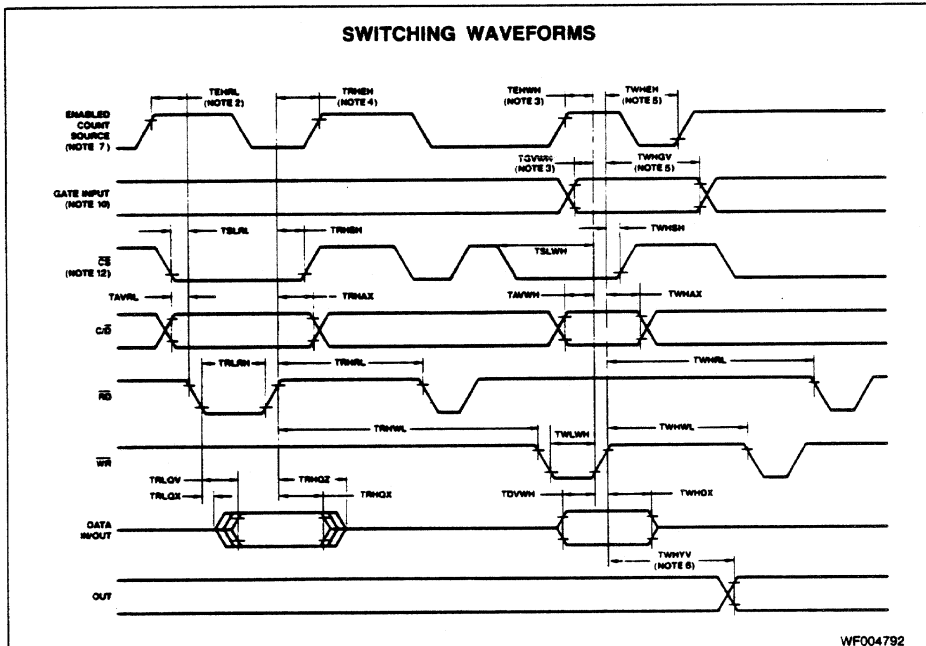

Figure 21. Bus Transfer Switching Waveforms

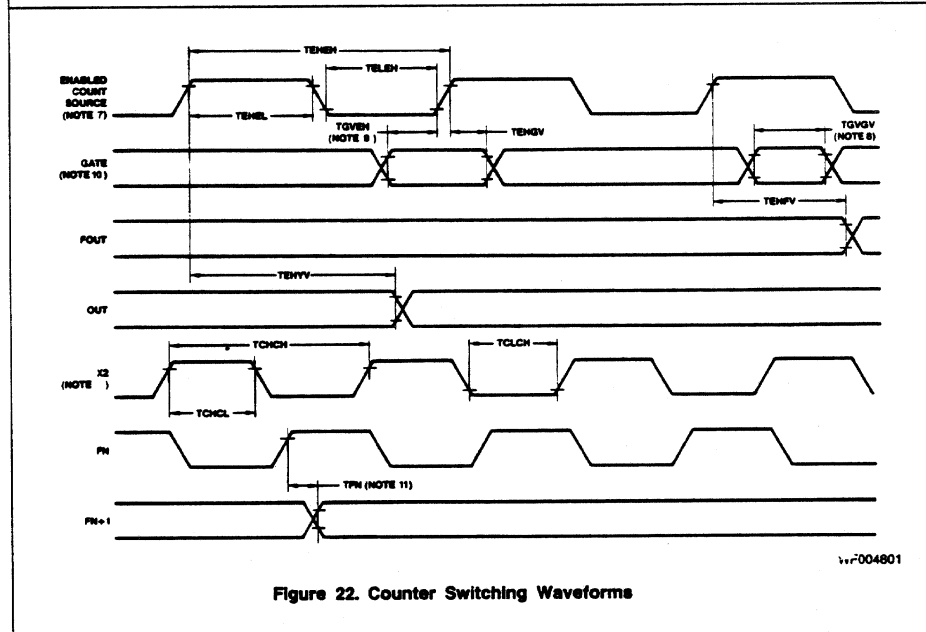

Figure 22. Counter Switching Waveforms

## APPENDIX A

## Design Hints

- 1) When a crystal is not being used, X1 and X2 should be connected as shown for TTL input (Figure A1) and no input (Figure A2).
- 2) Recommended oscillator capacitor values are 18 pF on X1 and X2.
- 3) Unused inputs should be tied to VCC.
- 4) The TC output can glitch when the counter is loaded. For this reason this output should not be connected to edge sensitive interrupts. The counter output should be set or cleared after the LOAD command.
- 5) The two most significant bits of the status register are not specified. They may be zero or one.
- 6) The mode register should not be modified when the counter is armed.
- 7) The LOAD and HOLD registers should not be changed during TC.
- 8) When using the different clocks for different counters be aware that there is a 75 ns skew between F1, F2, F3, F4 and F5.
- 9) The TC output will remain inactive if programmed to be in the TC TOGGLE mode and the step command is used to increment or decrement the counter. The output will go into TC if programmed to be in the active High or active Low terminal count modes. The only two ways out of TC in this case are:
  - Arming the counter and having an active source connected to it.
  - Issuing another step command.
- 10) Timing parameters TEHWH and TGVWH are specified as negative. The diagrams in Figure A3 show the relationship between these signals.
- 11) In mode X the counter will count all qualified source edges until the second (not the first) TC and then stop.
- 12) A TC can occur when the counters are loaded if the counter was stopped at FFFF<sub>H</sub> or 9999<sub>10</sub> in the count up mode or at count 0001 when counting down. This is because an internal TC is generated which forces TC to be generated on the next count pulse.
- 13) In modes that alternate the reload source between the load and the hold registers (e.g., mode J), if the counter is disarmed at 0001<sub>H</sub> for down counting or 9999<sub>10</sub> for BCD up counting or FFFF<sub>H</sub> for binary up counting and rearmed, the reload source after the first TC will be the load register instead of the hold register. To avoid this, issue a software "dummy" load to the counter immediately after the disarm command.
- 14) In the down counting mode of the Am9513A, if a 0001 is loaded into the counter and another LOAD COUNTER command is issued, the TC of that counter will go active. If the load register contents are subsequently changed, and the counter armed, the first clock edge will cause the new load register contents to transfer into the counter and the next clock edge will decrement the counter and make it go out of TC.
- 15) Glitches on  $\overline{CS}$  just before the  $\overline{RD}$  or  $\overline{WR}$  pulse may cause the part to behave incorrectly.
- 16) Timing parameters TGVEH & TEHGV must not be violated; Figure A4 shows a method.

2

## Troubleshooting (Symptom: Solution)

- 1) Registers not being programmed correctly: Check READ or WRITE recovery time.
- 2) Setup and hold problems observed in synchronous systems: Try switching from positive edge to negative edge triggering.

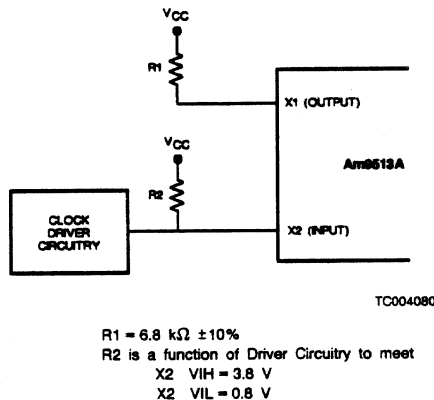

Figure A1. Crystal Input Configuration

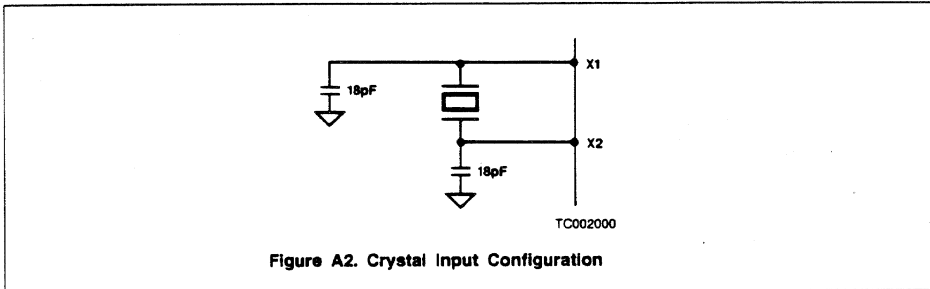

Figure A2. Crystal Input Configuration

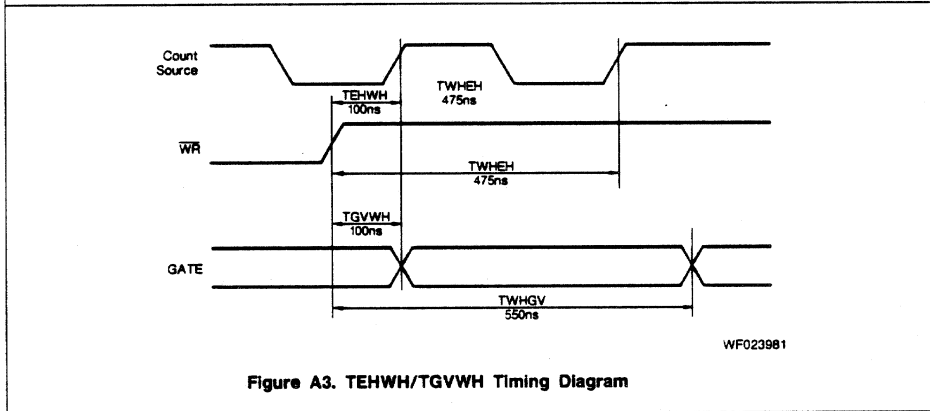

Figure A3. TEHWH/TGVWH Timing Diagram

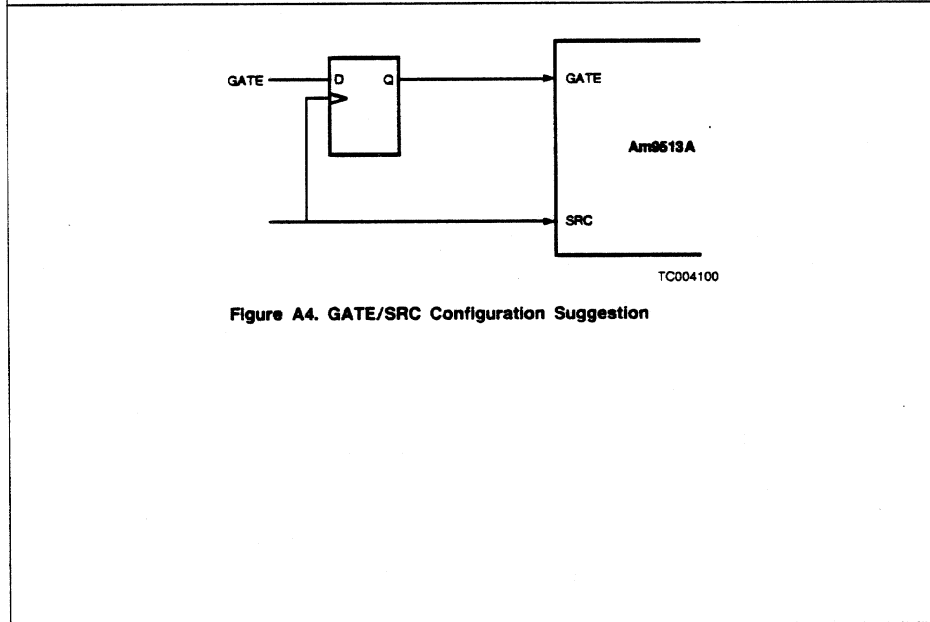

Figure A4. GATE/SRC Configuration Suggestion

# Customer Communication

---

Appendix

D

For your convenience, this appendix contains forms to help you gather the information necessary to help us solve your technical problems and a form you can use to comment on the product documentation. When you contact us, we need the information on the Technical Support Form and the configuration form, if your manual contains one, about your system configuration to answer your questions as quickly as possible.

National Instruments has technical assistance through electronic, fax, and telephone systems to quickly provide the information you need. Our electronic services include a bulletin board service, an FTP site, a Fax-on-Demand system, and e-mail support. If you have a hardware or software problem, first try the electronic support systems. If the information available on these systems does not answer your questions, we offer fax and telephone support through our technical support centers, which are staffed by applications engineers.

## Electronic Services



### Bulletin Board Support

National Instruments has BBS and FTP sites dedicated for 24-hour support with a collection of files and documents to answer most common customer questions. From these sites, you can also download the latest instrument drivers, updates, and example programs. For recorded instructions on how to use the bulletin board and FTP services and for BBS automated information, call (512) 795-6990. You can access these services at:

United States: (512) 794-5422

Up to 14,400 baud, 8 data bits, 1 stop bit, no parity

United Kingdom: 01635 551422

Up to 9,600 baud, 8 data bits, 1 stop bit, no parity

France: 01 48 65 15 59

Up to 9,600 baud, 8 data bits, 1 stop bit, no parity



### FTP Support

To access our FTP site, log on to our Internet host, `ftp.natinst.com`, as anonymous and use your Internet address, such as `joesmith@anywhere.com`, as your password. The support files and documents are located in the `/support` directories.





## Fax-on-Demand Support

Fax-on-Demand is a 24-hour information retrieval system containing a library of documents on a wide range of technical information. You can access Fax-on-Demand from a touch-tone telephone at (512) 418-1111.



## E-Mail Support (currently U.S. only)

You can submit technical support questions to the applications engineering team through e-mail at the Internet address listed below. Remember to include your name, address, and phone number so we can contact you with solutions and suggestions.

support@natinst.com

## Telephone and Fax Support

National Instruments has branch offices all over the world. Use the list below to find the technical support number for your country. If there is no National Instruments office in your country, contact the source from which you purchased your software to obtain support.

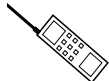

### Telephone



### Fax

Australia	03 9879 5166	03 9879 6277
Austria	0662 45 79 90 0	0662 45 79 90 19
Belgium	02 757 00 20	02 757 03 11
Canada (Ontario)	905 785 0085	905 785 0086
Canada (Quebec)	514 694 8521	514 694 4399
Denmark	45 76 26 00	45 76 26 02
Finland	09 725 725 11	09 725 725 55
France	01 48 14 24 24	01 48 14 24 14
Germany	089 741 31 30	089 714 60 35
Hong Kong	2645 3186	2686 8505
Israel	03 5734815	03 5734816
Italy	02 413091	02 41309215
Japan	03 5472 2970	03 5472 2977
Korea	02 596 7456	02 596 7455
Mexico	5 520 2635	5 520 3282
Netherlands	0348 433466	0348 430673
Norway	32 84 84 00	32 84 86 00
Singapore	2265886	2265887
Spain	91 640 0085	91 640 0533
Sweden	08 730 49 70	08 730 43 70
Switzerland	056 200 51 51	056 200 51 55
Taiwan	02 377 1200	02 737 4644
United Kingdom	01635 523545	01635 523154
United States	512 795 8248	512 794 5678

# Technical Support Form

Photocopy this form and update it each time you make changes to your software or hardware, and use the completed copy of this form as a reference for your current configuration. Completing this form accurately before contacting National Instruments for technical support helps our applications engineers answer your questions more efficiently.

If you are using any National Instruments hardware or software products related to this problem, include the configuration forms from their user manuals. Include additional pages if necessary.

Name \_\_\_\_\_

Company \_\_\_\_\_

Address \_\_\_\_\_

\_\_\_\_\_

Fax ( \_\_\_ ) \_\_\_\_\_ Phone ( \_\_\_ ) \_\_\_\_\_

Computer brand \_\_\_\_\_ Model \_\_\_\_\_ Processor \_\_\_\_\_

Operating system (include version number) \_\_\_\_\_

Clock speed \_\_\_\_\_ MHz RAM \_\_\_\_\_ MB Display adapter \_\_\_\_\_

Mouse \_\_\_yes \_\_\_no Other adapters installed \_\_\_\_\_

Hard disk capacity \_\_\_\_\_ MB Brand \_\_\_\_\_

Instruments used \_\_\_\_\_

\_\_\_\_\_

National Instruments hardware product model \_\_\_\_\_ Revision \_\_\_\_\_

Configuration \_\_\_\_\_

National Instruments software product \_\_\_\_\_ Version \_\_\_\_\_

Configuration \_\_\_\_\_

The problem is: \_\_\_\_\_

\_\_\_\_\_

\_\_\_\_\_

\_\_\_\_\_

List any error messages: \_\_\_\_\_

\_\_\_\_\_

\_\_\_\_\_

The following steps reproduce the problem: \_\_\_\_\_

\_\_\_\_\_

\_\_\_\_\_

\_\_\_\_\_

\_\_\_\_\_

\_\_\_\_\_

# AT-MIO-16X Hardware and Software Configuration Form

Record the settings and revisions of your hardware and software on the line to the right of each item. Complete a new copy of this form each time you revise your software or hardware configuration, and use this form as a reference for your current configuration. Completing this form accurately before contacting National Instruments for technical support helps our applications engineers answer your questions more efficiently.

## National Instruments Products

DAQ hardware \_\_\_\_\_

Interrupt level of hardware \_\_\_\_\_

DMA channels of hardware \_\_\_\_\_

Base I/O address of hardware \_\_\_\_\_

Programming choice \_\_\_\_\_

National Instruments Application Software \_\_\_\_\_

Other boards in system \_\_\_\_\_

Base I/O address of other boards \_\_\_\_\_

DMA channels of other boards \_\_\_\_\_

Interrupt level of other boards \_\_\_\_\_

## Other Products

Computer make and model \_\_\_\_\_

Microprocessor \_\_\_\_\_

Clock frequency or speed \_\_\_\_\_

Type of video board installed \_\_\_\_\_

Operating system version \_\_\_\_\_

Operating system mode \_\_\_\_\_

Programming language \_\_\_\_\_

Programming language version \_\_\_\_\_

Other boards in system \_\_\_\_\_

Base I/O address of other boards \_\_\_\_\_

DMA channels of other boards \_\_\_\_\_

Interrupt level of other boards \_\_\_\_\_

# Documentation Comment Form

National Instruments encourages you to comment on the documentation supplied with our products. This information helps us provide quality products to meet your needs.

**Title:** *AT-MIO-16X User Manual*

**Edition Date:** October 1997

**Part Number:** 320640B-01

Please comment on the completeness, clarity, and organization of the manual.

---

---

---

---

---

---

---

---

If you find errors in the manual, please record the page numbers and describe the errors.

---

---

---

---

---

---

---

---

Thank you for your help.

Name \_\_\_\_\_

Title \_\_\_\_\_

Company \_\_\_\_\_

Address \_\_\_\_\_

---

Phone ( \_\_\_ ) \_\_\_\_\_ Fax ( \_\_\_ ) \_\_\_\_\_

**Mail to:** Technical Publications  
National Instruments Corporation  
6504 Bridge Point Parkway  
Austin, TX 78730-5039

**Fax to:** Technical Publications  
National Instruments Corporation  
(512) 794-5678

<b>Prefix</b>	<b>Meanings</b>	<b>Value</b>
p-	pico-	$10^{-12}$
n-	nano-	$10^{-9}$
$\mu$ -	micro-	$10^{-6}$
m-	milli-	$10^{-3}$
k-	kilo-	$10^3$
M-	mega-	$10^6$
G-	giga-	$10^9$

## **Numbers/Symbols**

%	percent
+	positive of, or plus
-	negative of, or minus
/	per
°	degree
$\Omega$	ohm

## **A**

A	amperes
AC	alternating current

AC coupled	allowing the transmission of AC signals while blocking DC signals
A/D	analog-to-digital
ADC	analog-to-digital converter—an electronic device, often an integrated circuit, that converts an analog voltage to a digital number
ADC resolution	the resolution of the ADC, which is measured in bits. An ADC with 16 bits has a higher resolution, and thus a higher degree of accuracy, than a 12-bit ADC.
address	character code that identifies a specific location (or series of locations) in memory
alias	a false lower frequency component that appears in sampled data acquired at too low a sampling rate
ALU	arithmetic logic unit—the element(s) in a processing system that perform(s) the mathematical functions such as addition, subtraction, multiplication, division, inversion, AND, OR, NAND, and NOR
AMD	Advanced Micro Devices
amplification	a type of signal conditioning that improves accuracy in the resulting digitized signal and reduces noise
amplitude flatness	a measure of how close to constant the gain of a circuit remains over a range of frequencies
ANSI	American National Standards Institute
ASIC	Application-Specific Integrated Circuit—a proprietary semiconductor component designed and manufactured to perform a set of specific functions for a specific customer
asynchronous	(1) hardware—a property of an event that occurs at an arbitrary time, without synchronization to a reference clock (2) software—a property of a function that begins an operation and returns prior to the completion or termination of the operation
attenuate	to decrease the amplitude of a signal
attenuation ratio	the factor by which a signal's amplitude is decreased
AWG	American Wire Gauge

**B**

b	bit—one binary digit, either 0 or 1
B	byte—eight related bits of data, an eight-bit binary number. Also used to denote the amount of memory required to store one byte of data.
bandwidth	the range of frequencies present in a signal, or the range of frequencies to which a measuring device can respond
base address	a memory address that serves as the starting address for programmable registers. All other addresses are located by adding to the base address.
baud rate	serial communications data transmission rate expressed in bits per second (b/s)
BCD	binary-coded decimal
binary	a number system with a base of 2
BIOS	basic input/output system- BIOS functions are the fundamental level of any PC or compatible computer. BIOS functions embody the basic operations needed for successful use of the computer's hardware resources.
bipolar	a signal range that includes both positive and negative values (for example, -5 V to +5 V)
BNC	a type of coaxial signal connector
break-before-make	a type of switching contact that is completely disengaged from one terminal before it connects with another terminal
breakdown voltage	the voltage high enough to cause breakdown of optical isolation, semiconductors, or dielectric materials. <i>See also</i> working voltage.
buffer	temporary storage for acquired or generated data (software)
burst-mode	a high-speed data transfer in which the address of the data is sent followed by back-to-back data words while a physical signal is asserted
bus	the group of conductors that interconnect individual circuitry in a computer. Typically, a bus is the expansion vehicle to which I/O or other devices are connected. Examples of PC buses are the AT bus, NuBus, Micro Channel, and EISA bus.

bus master                    a type of a plug-in board or controller with the ability to read and write devices on the computer bus

## **C**

C                                Celsius

cache                         high-speed processor memory that buffers commonly used instructions or data to increase processing throughput

CalDAC                        calibration DAC

capacitively coupled

cascading                    process of extending the counting range of a counter chip by connecting to the next higher counter

channel                        pin or wire lead to which you apply or from which you read the analog or digital signal. Analog signals can be single-ended or differential. For digital signals, you group channels to form ports. Ports usually consist of either four or eight digital channels.

channel clock                the clock controlling the time interval between individual channel sampling within a scan. Boards with simultaneous sampling do not have this clock.

chromatograph              an instrument used in chemical analysis of gases and liquids.

CI                                computing index

circuit trigger                a condition for starting or stopping clocks

clock                            hardware component that controls timing for reading from or writing to groups

CMOS                          complementary metal-oxide semiconductor

CMRR                          common-mode rejection ratio—a measure of an instrument's ability to reject interference from a common-mode signal, usually expressed in decibels (dB)

code width                    the smallest detectable change in an input voltage of a DAQ device

cold-junction  
compensation                a method of compensating for inaccuracies in thermocouple circuits



common-mode range	the input range over which a circuit can handle a common-mode signal
common-mode signal	the mathematical average voltage, relative to the computer's ground, of the signals from a differential input
common-mode voltage	any voltage present at the instrumentation amplifier inputs with respect to amplifier ground
compensation range	the range of a parameter for which compensating adjustment can be made
conditional retrieval	a method of triggering in which you simulate an analog trigger using software. Also called software triggering.
conversion device	device that transforms a signal from one form to another. For example, analog-to-digital converters (ADCs) for analog input, digital-to-analog converters (DACs) for analog output, digital input or output ports, and counter/timers are conversion devices.
conversion time	the time required, in an analog input or output system, from the moment a channel is interrogated (such as with a read instruction) to the moment that accurate data is available
counter/timer	a circuit that counts external pulses or clock pulses (timing)
coupling	the manner in which a signal is connected from one location to another
CPU	central processing unit
crosstalk	an unwanted signal on one channel due to an input on a different channel
current drive capability	the amount of current a digital or analog output channel is capable of sourcing or sinking while still operating within voltage range specifications
current sinking	the ability of a DAQ board to dissipate current for analog or digital output signals
current sourcing	the ability of a DAQ board to supply current for analog or digital output signals

## D

D/A	digital-to-analog.
DAC	digital-to-analog converter—an electronic device, often an integrated circuit, that converts a digital number into a corresponding analog voltage or current
daisy-chain	a method of propagating signals along a bus, in which the devices are prioritized on the basis of their position on the bus
DAQ	data acquisition—(1) collecting and measuring electrical signals from sensors, transducers, and test probes or fixtures and inputting them to a computer for processing; (2) collecting and measuring the same kinds of electrical signals with A/D and/or DIO boards plugged into a computer, and possibly generating control signals with D/A and/or DIO boards in the same computer
dB	decibel—the unit for expressing a logarithmic measure of the ratio of two signal levels: $dB=20\log_{10} V_1/V_2$ , for signals in volts
DC	direct current
DC coupled	allowing the transmission of both AC and DC signals
DCS	distributed control system—a large-scale process control system characterized by a distributed network of processors and I/O subsystems that encompass control, user interfacing, data collection, and system management. DCSs are commonly used in large industrial facilities, such as a petroleum refinery or paper mill.
default setting	a default parameter value recorded in the driver. In many cases, the default input of a control is a certain value (often 0) that means <i>use the current default setting</i> . For example, the default input for a parameter may be <i>do not change current setting</i> , and the default setting may be <i>no AMUX-64T boards</i> . If you do change the value of such a parameter, the new value becomes the new setting. You can set default settings for some parameters in the configuration utility or manually using switches located on the device.
delta-sigma modulating ADC	a high-accuracy circuit that samples at a higher rate and lower resolution than is needed and (by means of feedback loops) pushes the quantization noise above the frequency range of interest. This out-of-band noise is typically removed by digital filters.

derivative control	a control action with an output that is proportional to the rate of change of the error signal. Derivative control anticipates the magnitude difference between the process variable and the setpoint.
device	a plug-in data acquisition board, card, or pad that can contain multiple channels and conversion devices. Plug-in boards, PCMCIA cards, and devices such as the DAQPad-1200, which connects to your computer parallel port, are all examples of DAQ devices. SCXI modules are distinct from devices, with the exception of the SCXI-1200, which is a hybrid.
DIFF	differential mode
differential input	an analog input consisting of two terminals, both of which are isolated from computer ground, whose difference is measured
differential measurement system	a way you can configure your device to read signals, in which you do not need to connect either input to a fixed reference, such as the earth or a building ground
digital port	<i>See</i> port.
digital trigger	a TTL level signal having two discrete levels—a high and a low level
DIN	Deutsche Industrie Norme
DIO	digital input/output
DIP	dual inline package
dithering	the addition of Gaussian noise to an analog input signal
DMA	direct memory access—a method by which data can be transferred to/from computer memory from/to a device or memory on the bus while the processor does something else. DMA is the fastest method of transferring data to/from computer memory.
DNL	differential nonlinearity—a measure in LSB of the worst-case deviation of code widths from their ideal value of 1 LSB
DOS	disk operating system
down counter	performing frequency division on an internal signal
DRAM	dynamic RAM

drivers	software that controls a specific hardware device such as a DAQ board or a GPIB interface board
DSP	digital signal processing
dual-access memory	memory that can be sequentially accessed by more than one controller or processor but not simultaneously accessed. Also known as shared memory.
dual-ported memory	memory that can be simultaneously accessed by more than one controller or processor
dynamic range	the ratio of the largest signal level a circuit can handle to the smallest signal level it can handle (usually taken to be the noise level), normally expressed in dB
<b>E</b>	
ECL	emitter-coupled logic
EEPROM	electrically erasable programmable read-only memory—ROM that can be erased with an electrical signal and reprogrammed
EGA	enhanced graphics adapter
EISA	extended industry standard architecture
electrostatically coupled	propagating a signal by means of a varying electric field
EMC	electromechanical compliance
encoder	a device that converts linear or rotary displacement into digital or pulse signals. The most popular type of encoder is the optical encoder, which uses a rotating disk with alternating opaque areas, a light source, and a photodetector.
EPROM	erasable programmable read-only memory—ROM that can be erased (usually by ultraviolet light exposure) and reprogrammed
ETS	equivalent-time sampling
event	the condition or state of an analog or digital signal
expansion ROM	an onboard EEPROM that may contain device-specific initialization and system boot functionality

external trigger a voltage pulse from an external source that triggers an event such as A/D conversion

## F

F farads

false triggering triggering that occurs at an unintended time

fetch-and-deposit a data transfer in which the data bytes are transferred from the source to the controller, and then from the controller to the target

Fieldbus an all-digital communication network used to connect process instrumentation and control systems; it will ultimately replace existing 4–20 mA analog standard

Fieldbus Foundation the organization located in Austin, TX, that is developing a standard digital communication network (fieldbus) for industrial automation applications. The network developed by the Foundation is referred to as the Foundation Fieldbus.

FIFO first-in first-out memory buffer—the first data stored is the first data sent to the acceptor. FIFOs are often used on DAQ devices to temporarily store incoming or outgoing data until that data can be retrieved or output. For example, an analog input FIFO stores the results of A/D conversions until the data can be retrieved into system memory, a process that requires the servicing of interrupts and often the programming of the DMA controller. This process can take several milliseconds in some cases. During this time, data accumulates in the FIFO for future retrieval. With a larger FIFO, longer latencies can be tolerated. In the case of analog output, a FIFO permits faster update rates, because the waveform data can be stored on the FIFO ahead of time. This again reduces the effect of latencies associated with getting the data from system memory to the DAQ device.

filtering a type of signal conditioning that allows you to filter unwanted signals from the signal you are trying to measure

flash ADC an ADC whose output code is determined in a single step by a bank of comparators and encoding logic

floating signal sources signal sources with voltage signals that are not connected to an absolute reference or system ground. Also called nonreferenced signal sources.

Some common example of floating signal sources are batteries, transformers, or thermocouples.

flyby a type of high-performance data transfer in which the data bytes pass directly from the source to the target without being transferred to the controller

FSR full-scale range

ft feet

## G

gain the factor by which a signal is amplified, sometimes expressed in decibels

gain accuracy a measure of deviation of the gain of an amplifier from the ideal gain

GATE input pin a counter input pin that controls when counting occurs in your application

glitch

GPIB General Purpose Interface bus, synonymous with HP-IB. The standard bus used for controlling electronic instruments with a computer. Also called IEEE 488 bus because it is defined by ANSI/IEEE Standards 488-1978, 488.1-1987, and 488.2-1987.

$g_{rms}$  level of random vibration

grounded measurement system *See* referenced single-ended measurement system.

## H

h hour

half-flash ADC an ADC that determines its output code by digitally combining the results of two sequentially performed, lower-resolution flash conversions

half-power bandwidth the frequency range over which a circuit maintains a level of at least  $-3$  dB with respect to the maximum level

handle	pointer to a pointer to a block of memory; handles reference arrays and strings. An array of strings is a handle to a block of memory containing handles to strings.
handler	a device driver that is installed as part of the operating system of the computer
handshaked digital I/O	a type of digital acquisition/generation where a device or module accepts or transfers data after a digital pulse has been received. Also called latched digital I/O.
hardware	the physical components of a computer system, such as the circuit boards, plug-in boards, chassis, enclosures, peripherals, cables, and so on
hardware triggering	a form of triggering where you set the start time of an acquisition and gather data at a known position in time relative to a trigger signal
HCT	high-speed CMOS TTL
hex	hexadecimal
Hz	hertz—the number of scans read or updates written per second
<b>I</b>	
IBM	International Business Machines
IC	integrated circuit
ID	identification
IDE	integrated development environment
IEEE	Institute of Electrical and Electronics Engineers
IEEE 488	the shortened notation for ANSI/IEEE Standards 488-1978, 488.1-1987, and 488.2-1987. See also GPIB.
IMD	intermodulation distortion—the ratio, in dB, of the total rms signal level of harmonic sum and difference distortion products, to the overall rms signal level. The test signal is two sine waves added together according to the following standards: SMPTE—A 60 Hz sine wave and a 7 kHz

sine wave added in a 4:1 amplitude ratio.  
DIN—A 250 Hz sine wave and an 8 kHz sine wave added in a 4:1 amplitude ratio.  
CCIF—A 14 kHz sine wave and a 15 kHz sine wave added in a 1:1 amplitude ratio.

immediate digital I/O	a type of digital acquisition/generation where LabVIEW updates the digital lines or port states immediately or returns the digital value of an input line. Also called nonlatched digital I/O.
in.	inches
Industrial Device Networks	standardized digital communications networks used in industrial automation applications; they often replace vendor-proprietary networks so that devices from different vendors can communicate in control systems
INL	integral nonlinearity—a measure in LSB of the worst-case deviation from the ideal A/D or D/A transfer characteristic of the analog I/O circuitry
input bias current	the current that flows into the inputs of a circuit
input impedance	the measured resistance and capacitance between the input terminals of a circuit
input offset current	the difference in the input bias currents of the two inputs of an instrumentation amplifier
instrument driver	a set of high-level software functions that controls a specific GPIB, VXI, or RS-232 programmable instrument or a specific plug-in DAQ board. Instrument drivers are available in several forms, ranging from a function callable language to a virtual instrument (VI) in LabVIEW.
instrumentation amplifier	a circuit whose output voltage with respect to ground is proportional to the difference between the voltages at its two inputs
integral control	a control action that eliminates the offset inherent in proportional control
integrating ADC	an ADC whose output code represents the average value of the input voltage over a given time interval
interrupt	a computer signal indicating that the CPU should suspend its current task to service a designated activity



interrupt level	the relative priority at which a device can interrupt
interval scanning	scanning method where there is a longer interval between scans than there is between individual channels comprising a scan
I/O	input/output—the transfer of data to/from a computer system involving communications channels, operator interface devices, and/or data acquisition and control interfaces
$I_{OH}$	current, output high
$I_{OL}$	current, output low
IRQ	interrupt request
ISA	industry standard architecture
isolation	a type of signal conditioning in which you isolate the transducer signals from the computer for safety purposes. This protects you and your computer from large voltage spikes and makes sure the measurements from the DAQ device are not affected by differences in ground potentials.
isolation voltage	the voltage that an isolated circuit can normally withstand, usually specified from input to input and/or from any input to the amplifier output, or to the computer bus
isothermal	constructed to maintain constant temperature across area. Isothermal construction of terminal blocks increases thermocouple measurement accuracy.
<b>K</b>	
k	kilo—the standard metric prefix for 1,000, or $10^3$ , used with units of measure such as volts, hertz, and meters
K	kilo—the prefix for 1,024, or $2^{10}$ , used with B in quantifying data or computer memory
kbytes/s	a unit for data transfer that means 1,000 or $10^3$ bytes/s
kS	1,000 samples
Kword	1,024 words of memory

## L

LabVIEW	laboratory virtual instrument engineering workbench
latch	
latched digital I/O	a type of digital acquisition/generation where a device or module accepts or transfers data after a digital pulse has been received. Also called handshaked digital I/O.
LED	light-emitting diode
library	a file containing compiled object modules, each comprised of one of more functions, that can be linked to other object modules that make use of these functions. NIDAQMSC.LIB is a library that contains NI-DAQ functions. The NI-DAQ function set is broken down into object modules so that only the object modules that are relevant to your application are linked in, while those object modules that are not relevant are not linked.
linearity	the adherence of device response to the equation $R = KS$ , where $R$ = response, $S$ = stimulus, and $K$ = a constant
linearization	a type of signal conditioning in which software linearizes the voltage levels from transducers, so the voltages can be scaled to measure physical phenomena
listener	a device on the GPIB that receives information from a Talker on the bus
low frequency corner	in an AC-coupled circuit, the frequency below which signals are attenuated by at least 3 dB
LS	low-power schottsky
LSB	least significant bit

## M

m	meters
M	(1) Mega, the standard metric prefix for 1 million or $10^6$ , when used with units of measure such as volts and hertz; (2) mega, the prefix for 1,048,576, or $2^{20}$ , when used with B to quantify data or computer memory

MB	megabytes of memory
MBLT	eight-byte block transfers in which both the Address bus and the Data bus are used to transfer data
Mbytes/s	a unit for data transfer that means 1 million or $10^6$ bytes/s
memory buffer	<i>See</i> buffer.
MFLOPS	million floating-point operations per second—the unit for expressing the computational power of a processor
MIO	multifunction I/O
MIPS	million instructions per second—the unit for expressing the speed of processor machine code instructions
MITE	MXI Interfaces to Everything is a custom ASIC designed by National Instruments that implements the PCI bus interface. The MITE supports bus mastering for high speed data transfers over the PCI bus.
MS	million samples
MSB	most significant bit
MTBF	mean time between failure
multiplexed mode	an SCXI operating mode in which analog input channels are multiplexed into one module output so that your cabled DAQ device has access to the module's multiplexed output as well as the outputs on all other multiplexed modules in the chassis through the SCXI bus. Also called serial mode.
mux	multiplexer—a switching device with multiple inputs that sequentially connects each of its inputs to its output, typically at high speeds, in order to measure several signals with a single analog input channel
<b>N</b>	
NB	NuBus—a slot-dependent, 32-bit bus type used in Macintosh computers that has 32 interrupts and doesn't use DMA
NC	normally closed, or not connected
NI-DAQ	NI driver software for DAQ hardware

NIST	National Institute of Standards and Technology
nodes	execution elements of a block diagram consisting of functions, structures, and subVIs
noise	an undesirable electrical signal—Noise comes from external sources such as the AC power line, motors, generators, transformers, fluorescent lights, soldering irons, CRT displays, computers, electrical storms, welders, radio transmitters, and internal sources such as semiconductors, resistors, and capacitors. Noise corrupts signals you are trying to send or receive.
nonlatched digital I/O	a type of digital acquisition/generation where LabVIEW updates the digital lines or port states immediately or returns the digital value of an input line. Also called immediate digital I/O or non-handshaking.
nonreferenced signal sources	signal sources with voltage signals that are not connected to an absolute reference or system ground. Also called floating signal sources. Some common example of nonreferenced signal sources are batteries, transformers, or thermocouples.
NRSE	nonreferenced single-ended mode—all measurements are made with respect to a common (NRSE) measurement system reference, but the voltage at this reference can vary with respect to the measurement system ground
Nyquist Sampling Theorem	a law of sampling theory stating that if a continuous bandwidth-limited signal contains no frequency components higher than half the frequency at which it is sampled, then the original signal can be recovered without distortion

## 0

onboard channels	channels provided by the plug-in data acquisition board
onboard RAM	optional RAM usually installed into SIMM slots
OpenDoc	a compound document architecture created by the joining of several technologies supplied by Apple (the base OpenDoc architecture, the Bento file system and the Open Scripting Architecture) and IBM (the System Object Model)

operating system	base-level software that controls a computer, runs programs, interacts with users, and communicates with installed hardware or peripheral devices
optical coupler, optocoupler	a device designed to transfer electrical signals by utilizing light waves to provide coupling with electrical isolation between input and output. Sometimes called optoisolator or photocoupler.
optical isolation	the technique of using an optoelectric transmitter and receiver to transfer data without electrical continuity, to eliminate high-potential differences and transients
OUT	output pin—a counter output pin where the counter can generate various TTL pulse waveforms
output settling time	the amount of time required for the analog output voltage to reach its final value within specified limits
output slew rate	the maximum rate of change of analog output voltage from one level to another

## P

parallel mode	a type of SCXI operating mode in which the module sends each of its input channels directly to a separate analog input channel of the device to the module
passband	the range of frequencies which a device can properly propagate or measure
pattern generation	a type of handshaked (latched) digital I/O in which internal counters generate the handshaked signal, which in turn initiates a digital transfer. Because counters output digital pulses at a constant rate, this means you can generate and retrieve patterns at a constant rate because the handshaked signal is produced at a constant rate.
PC Card	a credit-card-sized expansion card that fits in a PCMCIA slot often referred to as a PCMCIA card
PCI	Peripheral Component Interconnect—a high-performance expansion bus architecture originally developed by Intel to replace ISA and EISA. It is achieving widespread acceptance as a standard for PCs and workstations; it offers a theoretical maximum transfer rate of 132 Mbytes/s.

PCMCIA	an expansion bus architecture that has found widespread acceptance as a de facto standard in notebook-size computers. It originated as a specification for add-on memory cards written by the Personal Computer Memory Card International Association.
peak to peak	a measure of signal amplitude; the difference between the highest and lowest excursions of the signal
PFI	programmable function input
PGIA	programmable gain instrumentation amplifier
photoelectric sensor	an electrical device that responds to a change in the intensity of the light falling upon it
PID control	a three-term control mechanism combining proportional, integral, and derivative control actions. Also see proportional control, integral control, and derivative control.
pipeline	a high-performance processor structure in which the completion of an instruction is broken into its elements so that several elements can be processed simultaneously from different instructions
PLC	programmable logic controller—a highly reliable special-purpose computer used in industrial monitoring and control applications. PLCs typically have proprietary programming and networking protocols, and special-purpose digital and analog I/O ports.
Plug and Play devices	devices that do not require dip switches or jumpers to configure resources on the devices—also called switchless devices
Plug and Play ISA	a specification prepared by Microsoft, Intel, and other PC-related companies that will result in PCs with plug-in boards that can be fully configured in software, without jumpers or switches on the boards
port	(1) a communications connection on a computer or a remote controller (2) a digital port, consisting of four or eight lines of digital input and/or output
posttriggering	the technique used on a DAQ board to acquire a programmed number of samples after trigger conditions are met
potentiometer	an electrical device the resistance of which can be manually adjusted; used for manual adjustment of electrical circuits and as a transducer for linear or rotary position

ppm	parts per million
pretriggering	the technique used on a DAQ board to keep a continuous buffer filled with data, so that when the trigger conditions are met, the sample includes the data leading up to the trigger condition
propagation	the transmission of a signal through a computer system
propagation delay	the amount of time required for a signal to pass through a circuit
proportional control	a control action with an output that is to be proportional to the deviation of the controlled variable from a desired setpoint
protocol	the exact sequence of bits, characters, and control codes used to transfer data between computers and peripherals through a communications channel, such as the GPIB bus
proximity sensor	a device that detects the presence of an object without physical contact. Most proximity sensors provide a digital on/off relay or digital output signal.
pts	points
pulse trains	multiple pulses
pulsed output	a form of counter signal generation by which a pulse is outputted when a counter reaches a certain value

## Q

quantization error	the inherent uncertainty in digitizing an analog value due to the finite resolution of the conversion process
QuickTime	Apple system software tools that make video presentation a standard part of the Macintosh. Applications can use QuickTime to record and display audio and video in the same way applications use system tools to generate and display text and graphics.

## R

RAM	random-access memory
real time	a property of an event or system in which data is processed as it is acquired instead of being accumulated and processed at a later time
referenced signal sources	signal sources with voltage signals that are referenced to a system ground, such as the earth or a building ground. Also called grounded signal sources.
relative accuracy	a measure in LSB of the accuracy of an ADC. It includes all non-linearity and quantization errors. It does not include offset and gain errors of the circuitry feeding the ADC.
resolution	the smallest signal increment that can be detected by a measurement system. Resolution can be expressed in bits, in proportions, or in percent of full scale. For example, a system has 12-bit resolution, one part in 4,096 resolution, and 0.0244 percent of full scale.
resource locking	a technique whereby a device is signaled not to use its local memory while the memory is in use from the bus
retry	an acknowledge by a destination that signifies that the cycle did not complete and should be repeated
ribbon cable	a flat cable in which the conductors are side by side
rise time	the difference in time between the 10% and 90% points of a system's step response
rms	root mean square—the square root of the average value of the square of the instantaneous signal amplitude; a measure of signal amplitude
ROM	read-only memory
RSE	referenced single-ended mode—all measurements are made with respect to a common reference measurement system or a ground. Also called a grounded measurement system.
RTD	resistance temperature detector—a metallic probe that measures temperature based upon its coefficient of resistivity



RTSI	Real-Time System Integration
RTSI bus	real-time system integration bus—the National Instruments timing bus that connects DAQ boards directly, by means of connectors on top of the boards, for precise synchronization of functions
<b>S</b>	
s	seconds
S	samples
sample counter	the clock that counts the output of the channel clock, in other words, the number of samples taken. On boards with simultaneous sampling, this counter counts the output of the scan clock and hence the number of scans.
SCADA	supervisory control and data acquisition—a common PC function in process control applications, where programmable logic controllers (PLCs) perform control functions but are monitored and supervised by a PC
scan	one or more analog or digital input samples. Typically, the number of input samples in a scan is equal to the number of channels in the input group. For example, one pulse from the scan clock produces one scan which acquires one new sample from every analog input channel in the group.
scan clock	the clock controlling the time interval between scans. On boards with interval scanning support (for example, the AT-MIO-16F-5), this clock gates the channel clock on and off. On boards with simultaneous sampling (for example, the EISA-A2000), this clock clocks the track-and-hold circuitry.
scan rate	the number of scans per second. For example, a scan rate of 10 Hz means sampling each channel 10 times per second.
SCXI	Signal Conditioning eXtensions for Instrumentation—the National Instruments product line for conditioning low-level signals within an external chassis near sensors so only high-level signals are sent to DAQ boards in the noisy PC environment
SDK	software development kit

SE	single-ended—a term used to describe an analog input that is measured with respect to a common ground
self-calibrating	a property of a DAQ board that has an extremely stable onboard reference and calibrates its own A/D and D/A circuits without manual adjustments by the user
sensor	a device that responds to a physical stimulus (heat, light, sound, pressure, motion, flow, and so on), and produces a corresponding electrical signal
settling time	the amount of time required for a voltage to reach its final value within specified limits
S/H	sample-and-hold—a circuit that acquires and stores an analog voltage on a capacitor for a short period of time
shared memory	<i>See</i> dual-access memory
signal conditioning	the manipulation of signals to prepare them for digitizing
signal divider	performing frequency division on an external signal
SIMM	single in-line memory module
SMB	a type of miniature coaxial signal connector
SNR	signal-to-noise ratio—the ratio of the overall rms signal level to the rms noise level, expressed in dB
software trigger	a programmed event that triggers an event such as data acquisition
software triggering	a method of triggering in which you simulate an analog trigger using software. Also called conditional retrieval.
source impedance	a parameter of signal sources that reflects current-driving ability of voltage sources (lower is better) and the voltage-driving ability of current sources (higher is better)
SOURCE input pin	an counter input pin where the counter counts the signal transitions
SPDT	single-pole double throw—a property of a switch in which one terminal can be connected to one of two other terminals
SS	simultaneous sampling—a property of a system in which each input or output channel is digitized or updated at the same instant

S/s	samples per second—used to express the rate at which a DAQ board samples an analog signal
STC	system timing controller
strain gauge	a thin conductor, which is attached to a material, that detects stress or vibrations in that material. The conductor's resistance is a function of the applied force.
statically configured device	a device whose logical address cannot be set through software; that is, it is not dynamically configurable
successive-approximation ADC	an ADC that sequentially compares a series of binary-weighted values with an analog input to produce an output digital word in $n$ steps, where $n$ is the bit resolution of the ADC
switchless device	devices that do not require dip switches or jumpers to configure resources on the devices—also called Plug and Play devices
synchronous	(1) hardware—a property of an event that is synchronized to a reference clock (2) software—a property of a function that begins an operation and returns only when the operation is complete
system RAM	RAM installed on a personal computer and used by the operating system, as contrasted with onboard RAM
system noise	a measure of the amount of noise seen by an analog circuit or an ADC when the analog inputs are grounded

## T

TC	terminal count—the highest value of a counter
T/H	track-and-hold—a circuit that tracks an analog voltage and holds the value on command
THD	total harmonic distortion—the ratio of the total rms signal due to harmonic distortion to the overall rms signal, in dB or percent
THD+N	signal-to-THD plus noise—the ratio in decibels of the overall rms signal to the rms signal of harmonic distortion plus noise introduced

thermistor	a semiconductor sensor that exhibits a repeatable change in electrical resistance as a function of temperature. Most thermistors exhibit a negative temperature coefficient.
thermocouple	a temperature sensor created by joining two dissimilar metals. The junction produces a small voltage as a function of the temperature.
throughput rate	the data, measured in bytes/s, for a given continuous operation, calculated to include software overhead. Throughput Rate = Transfer Rate Software Overhead Factor.
top-level VI	VI at the top of the VI hierarchy. This term is used to distinguish the VI from its subVIs.
transducer	<i>See</i> sensor
transducer excitation	a type of signal conditioning that uses external voltages and currents to excite the circuitry of a signal conditioning system into measuring physical phenomena
transfer rate	the rate, measured in bytes/s, at which data is moved from source to destination after software initialization and set up operations; the maximum rate at which the hardware can operate
trigger	any event that causes or starts some form of data capture
TTL	transistor-transistor logic
<b>U</b>	
UART	universal asynchronous receiver/transmitter—an integrated circuit that converts parallel data to serial data (and vice versa), commonly used as a computer bus to serial device interface for serial communication
UI	update interval
unipolar	a signal range that is always positive (for example, 0 to +10 V)
update	the output equivalent of a scan. One or more analog or digital output samples. Typically, the number of output samples in an update is equal to the number of channels in the output group. For example, one pulse from the update clock produces one update which sends one new sample to every analog output channel in the group.

update rate                    the number of output updates per second

## V

V                                volts

$V_{DC}$                         volts direct current

VDMAD                        virtual DMA driver

VI                                virtual instrument—(1) a combination of hardware and/or software elements, typically used with a PC, that has the functionality of a classic stand-alone instrument (2) a LabVIEW software module (VI), which consists of a front panel user interface and a block diagram program

$V_{IH}$                         volts, input high

$V_{IL}$                         volts, input low

$V_{in}$                         volts in

VISA                            a new driver software architecture developed by National Instruments to unify instrumentation software GPIB, DAQ, and VXI. It has been accepted as a standard for VXI by the VXIplug&play Systems Alliance.

visual basic custom control (VBXs)                    a specific form of binary packaged object that can be created by different companies and integrated into applications written using Visual Basic

$V_{OH}$                         volts, output high

$V_{OL}$                         volts, output low

VPICD                        virtual programmable interrupt controller device

$V_{ref}$                         reference voltage

$V_{rms}$                         volts, root mean square

## W

waveform                    multiple voltage readings taken at a specific sampling rate

wire                            data path between nodes

## *Glossary*

word	the standard number of bits that a processor or memory manipulates at one time. Microprocessors typically use 8, 16, or 32-bit words.
working voltage	the highest voltage that should be applied to a product in normal use, normally well under the breakdown voltage for safety margin. See also Breakdown Voltage.

## **Z**

zero-overhead looping	the ability of a high-performance processor to repeat instructions without requiring time to branch to the beginning of the instructions
zero-wait-state memory	memory fast enough that the processor does not have to wait during any reads and writes to the memory

## Numbers

### +5 V signal

- description (table), 2-17, B-5
- power connections, 2-32 to 2-33

## A

### A2DRV bit

- description, 4-10
- RTSI switch signal connections, 5-38 to 5-39

### A2RCV bit

- description, 4-10
- RTSI switch signal connections, 5-38 to 5-39

### A4DRV bit

- description, 4-9
- RTSI switch signal connections, 5-38 to 5-39

### A4RCV bit

- description, 4-9
- RTSI switch signal connections, 5-38 to 5-39
- servicing update requests, 5-35

### A6 through A0 bits, 5-40

### ACH<0..15> signal (table), 2-17, B-4

### A/D conversion results

- in ADC FIFO, 4-32
- reading single conversion result, 5-7
- straight binary mode A/D conversion values (table), 4-33
- two's complement mode A/D conversion values (table), 4-34

### A/D converter, 3-6

### ADC\_BUSY\* bit, 4-30

### ADC Calibration Register, 4-52

### ADC conversion timing, 3-8

### ADC Event Strobe Register Group, 4-46 to 4-52

#### ADC Calibration Register, 4-52

#### CONFIGMEMCLR Register

- description, 4-47
- programming multiple-analog input channel configurations, 5-16
- programming single-analog input channel configurations, 5-15

#### CONFIGMEMLD Register

- description, 4-48
- programming multiple-analog input channel configurations, 5-16
- programming single-analog input channel configurations, 5-15

#### DAQ Clear Register

- clearing analog input circuitry, 5-14
- description, 4-49
- interrupt programming, 5-43
- programming DMA operations, 5-41

#### DAQ Start Register, 4-50

#### register map, 4-2

#### Single Conversion Register, 4-51

### ADC FIFO buffer

- ADC conversion timing (figure), 3-8
- analog input circuitry, 3-7

### ADC FIFO Register

- clearing analog input circuitry, 5-14
- description, 4-32 to 4-34
- interrupt programming, 5-43
- reading single conversion result, 5-7
- servicing data acquisition operation, 5-22

- ADCDSP bit, 4-13
- ADC\_FIFOEF\* bit
  - description, 4-26
  - DMA operations, 5-41
  - interrupt programming, 5-43
  - reading single conversion result, 5-7
  - servicing data acquisition operation, 5-22
- ADC\_FIFOHF\* bit
  - description, 4-26
  - DMA operations, 5-41
  - interrupt programming, 5-43
  - servicing data acquisition operation, 5-22
- ADC\_FOREQ bit, 4-23
- ADCREQ bit, 4-16 to 4-18
- address decoder circuitry, 3-3
- address latches, 3-3
- address lines, 3-3
- address selection. *See* base I/O address selection.
- ADIO<0..3> signal
  - description (table), 2-17, B-4
  - digital I/O circuitry, 3-24 to 3-25
  - digital I/O connections, 2-31 to 2-32
- ADIO<3..0> bits
  - Digital Input Register, 4-69
  - Digital Output Register, 4-70
  - programming digital I/O circuitry, 5-36
- AIGND signal
  - description (table), 2-17, B-4
  - differential connections for floating signal sources, 2-24 to 2-25
- AISENSE signal (table), 2-17, B-4
- Am9513A Counter/Timer Register Group, 4-64 to 4-67
  - Am9513A Command Register, 4-66
  - Am9513A Data Register, 4-65
  - Am9513A Status Register, 4-67
  - programming
    - general considerations, 5-37
    - resource allocation considerations, 5-1 to 5-2
    - sample counters, 5-17 to 5-20
    - sample-interval counter, 5-16 to 5-17
    - scan interval counter, 5-20 to 5-21
    - update-interval counter, 5-32 to 5-33
    - waveform cycle counter, 5-34
    - waveform cycle interval counter, 5-34 to 5-36
  - register map, 4-2
  - resetting after data acquisition operation, 5-23 to 5-24
- Am9513A System Timing Controller
  - data sheet, C-1 to C-40
  - initializing, 5-3 to 5-4
  - programming, 5-37
  - timing I/O circuitry, 3-25 to 3-29
- analog data acquisition rates
  - multiple-channel scanning rates, A-5 to A-6
  - single-channel rates, A-4
- analog input
  - calibration, 6-9 to 6-10
  - overview, 1-2
  - signal connections, 2-19 to 2-20
- analog input circuitry
  - A/D converter, 3-6
  - ADC FIFO buffer, 3-7
  - block diagram, 3-5
  - calibration, 3-7 to 3-8
  - clearing, 5-14
  - input configuration, 3-6 to 3-7
  - input multiplexers, 3-6
  - PGIA, 3-7
  - programming, 5-5 to 5-6
  - theory of operation, 3-6 to 3-8
- analog input configuration, 2-7 to 2-11
  - available input modes, 2-7 to 2-10
  - available configurations (table), 2-8
  - DIFF input, 2-8



- NRSE input, 2-9 to 2-10
- RSE input, 2-9
- common-mode signal rejection, 2-29
- considerations for selecting input ranges, 2-10
- differential connections
  - DIFF input configuration, 2-22
  - floating signal sources, 2-24 to 2-26
  - ground-referenced signal sources, 2-23
  - nonreferenced signal sources, 2-24 to 2-26
- input polarity and range, 2-10 to 2-11
- recommended configuration (table), 2-22
- single-ended connections, 2-26 to 2-27
  - floating signal sources (RSE configuration), 2-27
  - grounded signal sources (NRSE configuration), 2-28
- theory of operation, 3-6 to 3-7
- Analog Input Register Group, 4-31 to 4-40
  - ADC FIFO Register
    - clearing analog input circuitry, 5-14
    - description, 4-32 to 4-34
    - interrupt programming, 5-43
    - reading single conversion result, 5-7
    - servicing data acquisition operation, 5-22
  - CONFIGMEM Register
    - description, 4-35 to 4-40
    - programming multiple-analog input channel configurations, 5-16
    - programming single-analog input channel configurations, 5-15
  - register map, 4-1
- analog input specifications
  - linear errors, A-3 to A-4
    - equivalent gain errors in 16-bit systems (table), A-4
    - equivalent offset errors in 16-bit systems (table), A-3
    - gain error, A-3
    - postgain offset error, A-3
    - pregain offset error, A-3
  - list of specifications, A-1 to A-2
  - noise, A-4
  - nonlinear errors, A-4
    - differential nonlinearity, A-4
    - relative accuracy, A-4
  - system noise, A-4
- analog output
  - overview, 1-2
  - signal connections, 2-29 to 2-30
- analog output circuitry, 3-15 to 3-18
  - block diagram, 3-16
  - calibration, 3-17 to 3-18, 6-10 to 6-11
  - clearing, 5-32
  - configuration, 3-17
  - description, 3-16 to 3-17
  - programming, 5-25
- analog output configuration, 2-11 to 2-12.
  - See also* Command Register 2.
  - output polarity selection, 2-12
  - reference selection, 2-11
  - theory of operation, 3-17
- Analog Output Register Group, 4-41 to 4-43
  - analog output voltage *versus* digital code
    - bipolar mode (table), 4-42 to 4-43
    - unipolar mode (table), 4-42
  - DAC0 Register
    - description, 4-44
    - programming analog output circuitry, 5-25
  - DAC1 Register
    - description, 4-45
    - programming analog output circuitry, 5-25
  - formula for voltage output *versus* digital code, 4-42
  - overview, 4-41 to 4-43
  - register map, 4-2

- analog output specifications
  - differential nonlinearity, A-8
  - gain error, A-7
  - list of, A-6 to A-7
  - offset error, A-7
  - relative accuracy, A-7
- AOGND signal
  - analog output connections, 2-30
  - description (table), 2-17, B-4
- AT-MIO-16X. *See also* specifications; theory of operation.
  - block diagram, 3-1
  - features, 1-1 to 1-2
  - initializing, 5-2 to 5-3
  - National Instruments application
    - software, 1-4 to 1-5
  - optional equipment, 1-7
  - overview
    - analog input, 1-2
    - analog output, 1-2
    - digital and timing I/O, 1-3
  - requirements for getting started, 1-3 to 1-4
  - software programming choices
    - NI-DAQ driver software, 1-5 to 1-6
    - register-level programming, 1-6
  - unpacking, 1-7
- B**
- B6 through B0 bits, 5-40
- base I/O address selection, 2-3 to 2-6
  - changing software to match (note), 2-4
  - default settings of National Instruments products (table), 2-4 to 2-5
  - example switch settings (figure), 2-3
  - switch settings, with base I/O address and address space (table), 2-5 to 2-6
- BDIO<0..3> signal
  - description (table), 2-17, B-4
  - digital I/O circuitry, 3-24 to 3-25
  - digital I/O connections, 2-31 to 2-32
- BDIO<3..0> bits
  - Digital Input Register, 4-69
  - Digital Output Register, 4-70
  - programming digital I/O circuitry, 5-36
- BIPDAC0 bit, 4-10
- BIPDAC1 bit, 4-10
- bipolar input, 2-10
- bipolar mode, analog output voltage *versus* digital code (table), 4-42 to 4-43
- bipolar output, 2-12
- bits
  - A2DRV, 4-10, 5-38 to 5-39
  - A2RCV, 4-10, 5-38 to 5-39
  - A4DRV, 4-9, 5-38 to 5-39
  - A4RCV, 4-9, 5-35, 5-38 to 5-39
  - A6 through A0, 5-40
  - ADC\_BUSY\*, 4-30
  - ADC\_DSP, 4-13
  - ADCFIFOEF\*, 4-26, 5-7, 5-22, 5-41, 5-43
  - ADCFIFOHF\*, 4-26, 5-22, 5-41, 5-43
  - ADCFIFOREQ, 4-23
  - ADCREQ, 4-16 to 4-18
  - ADIO<3..0>, 4-69, 4-70, 5-36
  - B6 through B0 bits, 5-40
  - BDIO<3..0>, 4-69, 4-70, 5-36
  - BIPDAC0, 4-10
  - BIPDAC1, 4-10
  - BYTEPTR, 4-67
  - C<7..0>, 4-66
  - CFGMEMEF\*, 4-29
  - CHAN\_AIS, 4-35
  - CHAN\_BIP, 4-36
  - CHAN\_CAL, 4-35
  - CHAN\_DSP, 4-38 to 4-39
  - CHAN\_GHOST, 4-38
  - CHAN\_LAST, 4-38, 5-15
  - CHAN\_SE, 4-35
  - CHANSEL<3..0>, 4-36 to 4-37

CH\_GAIN<2..0>, 4-37 to 4-38  
 CLKMODEB<1..0>, 4-20 to 4-21  
 CNT32/16\*, 4-7 to 4-8, 5-18, 5-19  
 CYCLICSTOP, 3-22, 4-23, 5-26  
 D<15..0>, 4-44, 4-45, 4-65  
 DAC0DSP, 4-21  
 DAC0REQ, 4-18 to 4-19  
 DAC1DSP, 4-21  
 DAC1REQ, 4-18  
 DACCMPLINT, 4-14  
 DACCOMP, 4-28, 5-32, 5-36  
 DACFIFOEF\*, 4-28 to 4-29, 5-36  
 DACFIFOFF\*, 4-28, 5-41  
 DACFIFOHF\*, 4-28, 5-41  
 DACGATE, 4-22 to 4-23  
 DACMB<3..0>, 4-21 to 4-22  
 DAQCMPLINT, 4-14 to 4-15  
 DAQCOMP, 4-25, 5-36, 5-43  
 DAQEN, 4-6 to 4-7, 5-11, 5-14  
 DAQPROG, 4-25 to 4-26  
 DB\_DIS, 4-23  
 DIOPAEN, 4-14, 5-36  
 DIOPBEN, 4-13, 5-36  
 DMACHA, 4-15  
 DMACHAB<2..0>, 4-11 to 4-12  
 DMACHB, 4-15  
 DMACHBB<2..0>, 4-11  
 DMATCA, 4-26, 5-32, 5-41, 5-43  
 DMATCB, 4-26 to 4-27, 5-32, 5-41, 5-43  
 DMATCINT, 4-14  
 DRVAIS, 4-19  
 EEPROMC\*, 4-29  
 EEPROMCS, 4-5  
 EEPROMDATA, 4-29  
 EISA\_DMA, 4-11  
 EXTREFDAC0, 4-11  
 EXTREFDAC1, 4-11  
 EXTTRIG\_DIS, 4-24  
 FIFO/DAC, 4-24  
 GATE2SEL, 4-24, 5-32

INTCHB<2..0>, 4-19  
 INTGATE, 4-6  
 I/O\_INT, 4-15  
 OUT<5..1>, 4-67  
 OUTEN, 5-40  
 OVERFLOW, 4-27, 5-7, 5-22  
 OVERRUN, 4-27, 5-7, 5-22  
 RETRIG\_DIS, 4-6  
 RSI, 4-72  
 RTSITRIG, 4-8  
 S2 through S0 bits, 5-40  
 SCANDIV, 4-6, 5-15  
 SCANEN, 4-7, 5-11, 5-14  
 SCLK, 4-5 to 4-6  
 SCN2, 4-7, 5-14  
 SDATA, 4-5  
 SRC3SEL, 4-23 to 4-24, 5-30, 5-32  
 TMRREQ, 4-27 to 4-28, 5-32, 5-35, 5-43

board and RTSI clock selection. *See* Command Register 4; RTSI bus clock.

board configuration. *See* configuration.

bulletin board support, D-1 to D-2

BYTEPTR bit, 4-67

## C

C<7..0> bits, 4-66

cable considerations. *See also* I/O connectors.

field wiring considerations, 2-42 to 2-43

optional equipment, 1-7

Calibration DAC 0 Load Register, 4-62

Calibration DAC 1 Load Register, 4-63

calibration procedures

analog input calibration, 6-9 to 6-10

calibration DACs, 6-8

EEPROM

ADC and DAC FIFO Depth field (figure), 6-6

Area Information field (figure), 6-6

- Configuration Memory Depth Field (figure), 6-5
- EEPROM map, 6-2
- factory area information (table), 6-2 to 6-4
- Revision and Subrevision field (figure), 6-5
- storage area, 6-4
- equipment requirements, 6-7 to 6-8
- input calibration, 3-7 to 3-8
- output calibration, 3-17 to 3-18, 6-10 to 6-11
- reference calibration, 6-8 to 6-9
- CFGMEMEF\* bit, 4-29
- CHAN\_AIS bit, 4-35
- CHAN\_BIP bit, 4-36
- CHAN\_CAL bit, 4-35
- CHAN\_DSP bit, 4-38 to 4-39
- CHAN\_GHOST bit, 4-38
- CHAN\_LAST bit
  - description, 4-38
  - programming multiple-analog input channel configurations, 5-15
- channel scanning. *See* data acquisition programming.
- CHAN\_SE bit, 4-35
- CHANSEL<3..0> bits, 4-36 to 4-37
- CH\_GAIN<2..0> bits, 4-37 to 4-38
- CLKMODEB<1..0> bits, 4-20 to 4-21
- CNT32/16\* bit
  - description, 4-7 to 4-8
  - sample counting, 5-18, 5-19
- Command Register 1, 4-5 to 4-8
- Command Register 2
  - description, 4-9 to 4-12
  - interrupt programming, 5-43
  - programming digital I/O circuitry, 5-36
- Command Register 3, 4-13 to 4-19
- Command Register 4, 4-20 to 4-24
- common-mode signal rejection, 2-29
- ComponentWorks software, 1-4
- concatenating counters, 2-39
- CONFIGCLK signal, 3-29
- CONFIGMEM Register
  - description, 4-35 to 4-40
  - programming
    - multiple-analog input channel configurations, 5-16
    - single-analog input channel configurations, 5-15
- CONFIGMEMCLR Register
  - description, 4-47
  - programming
    - multiple-analog input channel configurations, 5-16
    - single-analog input channel configurations, 5-15
- CONFIGMEMLD Register
  - description, 4-48
  - programming
    - multiple-analog input channel configurations, 5-16
    - single-analog input channel configurations, 5-15
- configuration. *See also* input configurations; installation; signal connections.
  - analog input, 2-7 to 2-11
    - considerations for selecting input ranges, 2-10
    - input modes, 2-7 to 2-10
    - input polarity and range, 2-10 to 2-11
  - analog output, 2-11 to 2-12
    - output polarity selection, 2-12
    - reference selection, 2-11
  - AT bus interface, 2-2 to 2-3
  - base I/O address selection, 2-3 to 2-6
  - changing software to match (note), 2-4
  - default settings of National Instruments products (table), 2-4 to 2-5

- example switch settings (figure), 2-3
- switch settings, with base I/O address and address space (table), 2-5 to 2-6
- DMA channel selection, 2-7
- interrupt channel selection, 2-7
- Configuration and Status Register Group, 4-4 to 4-30
  - Command Register 1, 4-5 to 4-8
  - Command Register 2
    - description, 4-9 to 4-12
    - interrupt programming, 5-43
    - programming digital I/O circuitry, 5-36
  - Command Register 3, 4-13 to 4-19
  - Command Register 4, 4-20 to 4-24
  - overview, 4-4
  - register map, 4-1
  - Status Register 1
    - description, 4-25 to 4-29
    - servicing update requests, 5-36
  - Status Register 2, 4-30
- connectors. *See* I/O connectors.
- continuous channel scanning
  - definition, 5-10
  - programming, 5-10 to 5-11
- continuous scanning data acquisition
  - timing, 3-13
- counter block diagram, 3-27
- counter signal connections, 2-37 to 2-42
  - concatenating counters, 2-39
  - event-counting application, 2-37 to 2-38
  - frequency measurements, 2-39
  - input and output ratings, 2-40
  - overview, 2-37
  - pulse-width measurements, 2-38
  - time-lapse measurements, 2-38
  - timing requirements (figure), 2-41
  - timing specifications, 2-40 to 2-43

- counter/timer. *See* Am9513A Counter/Timer Register Group; Am9513A System Timing Controller.
- customer communication, xvii, D-1 to D-2
- cyclic waveform generation. *See* DAC waveform circuitry and timing; waveform generation programming.
- CYCLICSTOP bit
  - cyclic waveform generation, 3-22, 5-26
  - description, 4-23

## D

- D<15..0> bit
  - Am9513A Data Register, 4-65
  - DAC0 Register, 4-44
  - DAC1 Register, 4-45
- D<15..0> bits
  - ADC FIFO Register, 4-32 to 4-33
- DAC Clear Register
  - clearing analog output circuitry, 5-32
  - description, 4-56
  - DMA operations, 5-41
  - servicing update requests, 5-36
- DAC Event Strobe Register Group, 4-53 to 4-56
  - DAC Clear Register
    - clearing analog output circuitry, 5-32
    - description, 4-56
    - DMA operations, 5-41
    - servicing update requests, 5-36
  - DAC Update Register, 4-55
  - register map, 4-2
  - TMRREQ Clear Register
    - clearing analog output circuitry, 5-32
    - description, 4-54
    - DMA operations, 5-41
    - interrupt programming, 5-43
    - servicing update requests, 5-35 to 5-36

- DAC FIFO
  - continuous cyclic waveform generation, 3-22 to 3-23
  - cyclic waveform generation, 5-26 to 5-27
  - DAC waveform and circuitry timing, 3-19 to 3-22
  - DMA operations, 5-41
  - interrupt programming, 5-43
  - programmed cycle waveform generation, 5-28 to 5-30
  - programmed cyclic waveform generation, 3-23
  - programming analog output circuitry, 5-25
  - pulsed waveform generation, 3-23 to 3-24
- DAC Update Register, 4-55
- DAC waveform circuitry and timing, 3-18 to 3-24. *See also* waveform generation programming.
  - analog output waveform circuitry (figure), 3-21
  - DACMB<3..0> bits for selecting waveform modes, 4-21 to 4-22
  - FIFO continuous cyclic waveform generation, 3-22 to 3-23
  - FIFO programmed cyclic waveform generation, 3-23
  - FIFO pulsed waveform generation, 3-23 to 3-24
  - immediate updating of DACs, 3-18 to 3-19
  - posted DAC update timing (figure), 3-20
  - posted update mode, 3-18 to 3-20
  - waveform circuitry (figure), 3-19
  - waveform timing circuitry, 3-20 to 3-22
- DAC0 Register
  - description, 4-44
  - programming analog output circuitry, 5-25
- DAC0DSP bit, 4-21
- DAC0OUT signal
  - analog output connections, 2-29
  - description (table), 2-17, B-4
  - programming analog output circuitry, 5-25
- DAC0REQ bit, 4-18 to 4-19
- DAC1 Register
  - description, 4-45
  - programming analog output circuitry, 5-25
- DAC1DSP bit, 4-21
- DAC1OUT signal
  - analog output connections, 2-29
  - description (table), 2-17, B-4
  - programming analog output circuitry, 5-25
- DAC1REQ bit, 4-18
- DACCMLINT bit, 4-14
- DACCOMP bit
  - clearing analog output circuitry, 5-32
  - description, 4-28
  - servicing update requests, 5-36
- DACFIFOEF\* bit
  - description, 4-28 to 4-29
  - servicing update requests, 5-36
- DACFIFOFF\* bit
  - description, 4-28
  - programming DMA operations, 5-41
- DACFIFOHF\* bit
  - description, 4-28
  - programming DMA operations, 5-41
- DACFIFORT\* signal, 3-22
- DACGATE bit, 4-22 to 4-23
- DACMB<3..0> bits, 4-21 to 4-22
- DACs, analog output
  - circuitry, 3-16 to 3-17
  - immediate updating, 3-18 to 3-19
  - output configuration, 3-17
  - posted updating, 3-19 to 3-20
- DAQ Clear Register
  - clearing analog input circuitry, 5-14

- description, 4-49
- DMA operations, 5-41
- interrupt programming, 5-43
- DAQ Start Register, 4-50
- DAQCMLINT bit, 4-14 to 4-15
- DAQCOMP bit
  - description, 4-25
  - interrupt programming, 5-43
- DAQEN bit
  - continuous channel scanning data acquisition, 5-11
  - description, 4-6 to 4-7
  - interval-channel scanning data acquisition, 5-14
- DAQPROG bit, 4-25 to 4-26
- data acquisition mode selection. *See* Command Register 1.
- data acquisition programming, 5-14 to 5-36
  - analog input circuitry, 5-5 to 5-6
  - analog output circuitry, 5-25
  - applying a trigger, 5-21
  - channel scanning, 5-10 to 5-11
    - continuous channel scanning, 5-10 to 5-11
    - interval-channel scanning, 5-12 to 5-14
  - clearing analog input circuitry, 5-14
  - cyclic waveform generation, 5-26 to 5-27
  - multiple-analog input channel configurations, 5-15 to 5-16
  - programmed cycle waveform generation, 5-28 to 5-30
  - pulsed cyclic waveform generation, 5-30 to 5-32
  - resetting hardware, 5-22 to 5-24
  - sample counter(s), 5-17 to 5-20
  - sample-interval counter, 5-16 to 5-17
  - scan-interval counter, 5-20 to 5-21
  - servicing data acquisition operations, 5-22
  - single conversions
    - flow chart, 5-6
    - generating single conversions, 5-6
    - reading single conversion result, 5-7
    - using SCONVERT or EXTCONV\* signal, 5-5 to 5-6
  - single-analog input channel configurations, 5-15
  - single-channel data acquisition sequence, 5-7 to 5-9
  - waveform cycle counter, 5-34
  - waveform cycle interval counter, 5-34 to 5-36
  - waveform generation functions, 5-32
- data acquisition rates
  - multiple-channel scanning rates, A-5 to A-6
  - single-channel rates, A-4
- data acquisition timing circuitry
  - block diagram, 3-5
  - definition, 3-8
  - multiple-channel data acquisition, 3-12 to 3-15
  - rates of data acquisition, 3-15
  - single-channel data acquisition, 3-9 to 3-12
  - single-read timing, 3-8 to 3-9
  - theory of operation, 3-8 to 3-12
- data acquisition timing connections, 2-33 to 2-42
  - counter signal connections, 2-37 to 2-42
  - EXTCONVERT\* signal, 2-34
  - EXTGATE\* signal, 2-36
  - EXTSTROBE\* signal, 2-33
  - EXTTMRTRIG\* signal, 2-36
  - EXTTRIG\* signal, 2-35
  - SCANCLK signal, 2-33
- data buffers, PC I/O channel interface circuitry, 3-3
- DB\_DIS bit, 4-23
- DIFF (differential) input mode
  - definition (table), 2-8

- description, 2-22
- ground-referenced signal sources, 2-23
- nonreferenced or floating signal sources, 2-24 to 2-26
- recommended configuration (table), 2-22
- single-ended connections, 2-26 to 2-37
  - floating signal sources (RSE), 2-27
  - grounded signal sources (NRSE), 2-28
- when to use, 2-22
- differential nonlinearity errors
  - analog input, A-4
  - analog output, A-8
- DIGGND signal
  - description (table), 2-17, B-4
  - digital I/O connections, 2-31 to 2-32
- Digital Input Register. *See* Digital I/O Register Group.
- digital I/O
  - overview, 1-3
  - signal connections, 2-31 to 2-32
  - specifications, A-8
- digital I/O circuitry
  - block diagram, 3-24
  - programming, 5-36 to 5-37
  - theory of operation, 3-24 to 3-25
- Digital I/O Register Group, 4-68 to 4-70
  - Digital Input Register
    - description, 4-69
    - digital I/O circuitry, 3-25
    - programming digital I/O circuitry, 5-36
  - Digital Output Register
    - description, 4-70
    - overview, 3-25
    - programming digital I/O circuitry, 5-36
  - register map, 4-2
- Digital Output Register. *See* Digital I/O Register Group.
- DIOPAEN bit
  - description, 4-14
  - programming digital I/O circuitry, 5-36
- DIOPBEN bit
  - description, 4-13
  - programming digital I/O circuitry, 5-36
- DMA Channel Clear Register, 4-58
- DMA channels
  - configuring, 2-7
  - PC I/O channel interface, 3-4
- DMA operations, programming, 5-41 to 5-42
  - dual-channel interleaved mode, 5-42
  - procedure, 5-41 to 5-42
  - servicing update requests, 5-35 to 5-36
  - single-channel interleaved mode, 5-42
- DMA request generation
  - controlling with bits in Command Register 3, 4-13 to 4-19
    - DMA and interrupt modes (table), 4-16 to 4-17
    - interrupt level selection (table), 4-19
  - programming, 5-42
- DMACHA bit, 4-15
- DMACHAB<2..0> bits, 4-11 to 4-12
- DMACHB bit, 4-15
- DMACHBB<2..0> bits, 4-11
- DMATCA bit
  - clearing analog output circuitry, 5-32
  - description, 4-26
  - interrupt programming, 5-43
  - programming DMA operations, 5-42
- DMATCA Clear Register
  - clearing analog output circuitry, 5-32
  - description, 4-59
  - interrupt programming, 5-43
  - programming DMA operations, 5-42
- DMATCB bit
  - clearing analog output circuitry, 5-32
  - description, 4-26 to 4-27
  - interrupt programming, 5-43



- programming DMA operations, 5-42
- DMATCB Clear Register
  - clearing analog output circuitry, 5-32
  - description, 4-60
  - interrupt programming, 5-43
  - programming DMA operations, 5-41
- DMATCINT bit, 4-14
- documentation
  - conventions used in manual, *xvi*
  - organization of manual, *xv-xvi*
  - related documentation, *xvii*
- DRVAIS bit, 4-19

## E

- EEPROM
  - ADC and DAC FIFO Depth field (figure), 6-6
  - Area Information field (figure), 6-6
  - Configuration Memory Depth Field (figure), 6-5
  - EEPROM map, 6-2
  - factory area information (table), 6-2 to 6-4
  - Revision and Subrevision field (figure), 6-5
  - storage area, 6-4
- EEPROMCD\* bit, 4-29
- EEPROMCS bit, 4-5
- EEPROMDATA bit, 4-29
- EISA\_DMA bit, 4-11
- electronic support services, D-1 to D-2
- e-mail support, D-2
- environmental noise, avoiding, 2-42 to 2-43
- equipment, optional, 1-7
- event strobe registers. *See* ADC Event Strobe Register Group; DAC Event Strobe Register Group; General Event Strobe Register Group.
- event-counting application, 2-37 to 2-38
- EXTCONV\* signal

- description (table), 2-18, B-5
- generating single conversions, 5-5 to 5-6
- programming sample counter(s), 5-17
- programming sample-interval counter, 5-16
- RTSI switch, 3-30
- single-channel data acquisition, 3-9 to 3-10
- timing connections, 2-34
- updating DACs, 5-32
- External Strobe Register, 4-61
- EXTGATE\* signal
  - description (table), 2-18, B-5
  - timing connections, 2-36
- EXTREF signal
  - analog output connections, 2-29 to 2-30
  - analog output reference selection, 2-11
  - description (table), 2-17, B-4
- EXTREFDAC0 bit, 4-11
- EXTREFDAC1 bit, 4-11
- EXTSTROBE\* signal
  - description (table), 2-18, B-5
  - digital I/O circuitry, 3-25
  - timing connections, 2-33
- EXTTMRTRIG\* signal
  - DAC waveform timing circuitry, 3-20
  - description (table), 2-18, B-6
  - programming analog output circuitry, 5-25
  - servicing update requests, 5-35
  - timing connections, 2-36
- EXTTRIG\* signal
  - applying a trigger, 5-21
  - description (table), 2-18, B-5
  - programming sample-interval counter, 5-16
  - RTSI switch, 3-30
  - timing connections, 2-35
  - timing I/O circuitry, 3-28
- EXTTRIG\_DIS bit, 4-24

**F**

- fax and telephone support, D-2
- Fax-on-Demand support, D-2
- field wiring considerations, 2-42 to 2-43
- FIFO. *See* ADC FIFO Register; DAC FIFO.
- FIFO/DAC bit, 4-24
- floating signal sources
  - description, 2-21
  - differential connections, 2-24 to 2-26
  - recommended configuration (table), 2-22
  - single-ended connections (RSE configuration), 2-27
- FOUT signal
  - Am9513A programmable frequency output channel, 3-29
  - description (table), 2-19, B-6
  - RTSI switch connections, 3-30
  - timing signal source, 5-37
- frequency measurements, 2-39
- FTP support, D-1
- functional overview. *See* theory of operation.
- fuses and fusing
  - fusing of +5 V pin (table), 2-17, B-5
  - location of fuses (figure), 2-1, 2-2
  - power connections, 2-32

**G**

- gain error
  - analog input circuitry, A-3
  - analog output circuitry, A-7
- GATE, OUT, and SOURCE timing signals
  - counter signal connections, 2-37 to 2-42
  - RTSI bus interface circuitry, 3-30
  - timing I/O circuitry, 3-27 to 3-29
- GATE1 signal
  - description (table), 2-18, B-5
  - RTSI switch connections (table), 5-38
- GATE2 signal (table), 2-18, B-6
- GATE2SEL bit

- description, 4-24
- pulsed cyclic waveform generation, 5-30
- GATE5 signal (table), 2-18, B-6
- General Event Strobe Register Group, 4-57 to 4-63
  - Calibration DAC 0 Load Register, 4-62
  - Calibration DAC 1 Load Register, 4-63
  - DMA Channel Clear Register, 4-58
  - DMATCA Clear Register
    - clearing analog output circuitry, 5-32
    - description, 4-59
    - interrupt programming, 5-43
    - programming DMA operations, 5-41
  - DMATCB Clear Register
    - clearing analog output circuitry, 5-32
    - description, 4-60
    - interrupt programming, 5-43
    - programming DMA operations, 5-41
  - External Strobe Register, 4-61
  - register map, 4-2
- general-purpose timing signals. *See* counter signal connections.
- ground-referenced signal sources
  - description, 2-21
  - differential connections, 2-23
  - recommended configuration (table), 2-22
  - single-ended connections (NRSE configuration), 2-28

**H**

- hardware
  - installing, 2-13
  - resetting after data acquisition operation, 5-22 to 5-24

**I**

immediate update mode, 3-18

input configurations. *See also* CONFIGMEM Register.

- available input modes, 2-7 to 2-10
  - DIFF (table), 2-8
  - NRSE (table), 2-8
  - RSE (table), 2-8
- common-mode signal rejection, 2-29
- differential connections
  - DIFF input configuration, 2-22
  - floating signal sources, 2-24 to 2-26
  - ground-referenced signal sources, 2-23
  - nonreferenced signal sources, 2-24 to 2-26
- recommended configuration (table), 2-22
- single-ended connections, 2-26 to 2-27
  - floating signal sources (RSE configuration), 2-27
  - grounded signal sources (NRSE configuration), 2-28

input multiplexer

- address selection bits (CHANSEL <3..0>), 4-36 to 4-37
- description, 3-6

input polarity and range, 2-10 to 2-11

- actual range and measurement precision (table), 2-11
- selection considerations, 2-10

installation. *See also* configuration.

- hardware installation, 2-13
- unpacking AT-MIO-16X, 1-7

INTCHB<2..0> bits, 4-19

internal update counter, selecting, 5-32

interrupts

- controlling with bits in Command Register 3, 4-13 to 4-19
- interrupt channel selection, 2-7
- interrupt level selection (table), 4-19

- PC I/O channel interface, 3-4
  - programming, 5-43
- interval channel scanning
  - definition, 5-10
  - programming, 5-12 to 5-14
- interval scanning data acquisition timing, 3-14
- INTGATE bit, 4-6
- I/O connectors
  - cabling considerations
    - 50-pin I/O connector, 2-43 to 2-44
    - 68-pin I/O connector, 2-44
  - exceeding maximum ratings (warning), 2-14
  - pin assignments
    - 50-pin connector (figure), 2-15, B-2
    - 68-pin connector (figure), 2-16, B-3
  - signal descriptions (table), 2-17 to 2-19
- I/O\_INT bit, 4-15

**L**

LabVIEW and LabWindows/CVI software, 1-4

LASTONE bit, 5-16

linear errors

- equivalent gain errors in 16-bit systems (table), A-4
- equivalent offset errors in 16-bit systems (table), A-3
- gain error, A-3
- postgain offset error, A-3
- pregain offset error, A-3

**M**

manual. *See* documentation.

multiple-analog input channel configurations, programming, 5-15 to 5-16

multiple-channel data acquisition timing, 3-12 to 3-15

- continuous scanning, 3-13

- data acquisition rates, 3-15
- interval scanning, 3-14
- posttrigger data acquisition timing, 3-13
- multiple-channel scanning acquisition rates specifications, A-5 to A-6
- typical settling times (table), A-5
- multiplexer, input. *See* input multiplexer.

## N

- NI-DAQ driver software, 1-5 to 1-6
- noise
  - environmental, avoiding, 2-42 to 2-43
  - system noise, A-4
- nonlinear errors, A-4
  - differential nonlinearity, A-4
  - relative accuracy, A-4
- NRSE (nonreferenced single-ended input)
  - description (table), 2-8
  - differential connections, 2-24 to 2-26
  - recommended configuration (table), 2-22
  - single-ended connections (NRSE configuration), 2-28

## O

- offset error, analog output circuitry, A-7
- operating environment specifications, A-9
- operation of AT-MIO-16X. *See* theory of operation.
- optional equipment, 1-7
- OUT, GATE, and SOURCE timing signals
  - counter signal connections, 2-37 to 2-42
  - RTSI bus interface circuitry, 3-30
  - timing I/O circuitry, 3-27 to 3-29
- OUT<5..1> bits, 4-67
- OUT1 signal
  - description (table), 2-18, B-6
  - selecting internal update counter, 5-32
- OUT2 signal

- description (table), 2-18, B-6
- RTSI switch signal connections (table), 5-38
- selecting internal update counter, 5-32
- OUT3 signal, 5-32
- OUT5 signal
  - description (table), 2-19, B-6
  - RTSI switch signal connections (table), 5-38
  - selecting internal update counter, 5-32
- OUTEN bit, 5-40
- output polarity selection, 2-12
- OVERFLOW bit
  - ADC FIFO overflow condition, 5-7
  - description, 4-27
  - servicing data acquisition operation, 5-22
- OVERRUN bit
  - ADC overrun condition, 5-7
  - description, 4-27
  - servicing data acquisition operation, 5-22

## P

- PC I/O channel interface circuitry
  - block diagram, 3-3
  - theory of operation, 3-2 to 3-5
- PGIA (programmable gain instrumentation amplifier)
  - analog input circuitry, 3-7
  - common-mode signal rejection, 2-29
  - controlling with CH\_GAIN<2..0> bit, 4-37 to 4-38
  - differential connections
    - floating signal sources, 2-24 to 2-26
    - ground-referenced signal sources, 2-23
  - single-ended connections
    - floating signal sources (figure), 2-27
    - grounded signal sources (figure), 2-28

- physical specifications, A-9
- pin assignments. *See* I/O connectors.
- polarity
  - input polarity and range, 2-10 to 2-11
  - output polarity selection, 2-12
- posted update mode, 3-18 to 3-20
- postgain offset error, analog input circuitry, A-3
- posttrigger data acquisition timing
  - interval scanning data acquisition (figure), 3-14
  - multiple-channel data acquisition, 3-13
  - single-channel data acquisition, 3-10 to 3-11
- power connections, 2-32 to 2-33
- power requirements, A-9
- pregain offset error, A-3
- pretrigger data acquisition timing, 3-11 to 3-12
- programmable gain instrumentation amplifier. *See* PGIA (programmable gain instrumentation amplifier).
- programming. *See also* registers.
  - Am9513A Counter/Timer, 5-37
  - analog input circuitry, 5-5 to 5-6
  - data acquisition functions, 5-14 to 5-36
    - analog output circuitry, 5-25
    - applying a trigger, 5-21
    - clearing analog input circuitry, 5-14
    - cyclic waveform generation, 5-26 to 5-27
    - multiple-analog input channel configurations, 5-15 to 5-16
    - programmed cycle waveform generation, 5-28 to 5-30
    - pulsed cyclic waveform generation, 5-30 to 5-32
    - resetting hardware, 5-22 to 5-24
    - sample counter(s), 5-17 to 5-20
    - sample-interval counter, 5-16 to 5-17
    - scan-interval counter, 5-20 to 5-21
    - servicing data acquisition operations, 5-22
    - single-analog input channel configurations, 5-15
    - waveform cycle counter, 5-34
    - waveform cycle interval counter, 5-34 to 5-36
    - waveform generation functions, 5-32
  - data acquisition sequences with channel scanning, 5-10 to 5-11
    - continuous channel scanning, 5-10 to 5-11
    - interval-channel scanning, 5-12 to 5-14
  - digital I/O circuitry, 5-36 to 5-37
  - initialization
    - Am9513A, 5-3 to 5-4
    - AT-MIO-16X, 5-2 to 5-3
  - register programming considerations, 5-1
  - resource allocation considerations, 5-1 to 5-2
  - RTSI bus trigger line, 5-37 to 5-39
  - RTSI switch, 5-39 to 5-43
    - DMA operations, 5-41 to 5-42
    - interrupt programming, 5-43
    - signal connections, 5-37 to 5-39
  - single conversions
    - generating, 5-6
    - reading results, 5-7
    - using SCONVERT or EXTCONV\* signal, 5-5 to 5-6
  - single-channel data acquisition sequence, 5-7 to 5-9
- pseudo-simultaneous scanning, 5-10
- pulsed cyclic waveform generation, 5-30 to 5-32
- pulse-width measurements, 2-38

**R**

- reference calibration, 6-8 to 6-9
- reference selection, analog output, 2-11
- referenced single-ended input (RSE). *See* RSE (referenced single-ended input).
- register-level programming, 1-6
- registers
  - ADC Calibration Register, 4-52
  - ADC Event Strobe Register Group, 4-46 to 4-52
  - ADC FIFO Register
    - clearing analog input circuitry, 5-14
    - description, 4-32 to 4-34
    - interrupt programming, 5-43
    - reading single conversion result, 5-7
    - servicing data acquisition operation, 5-22
  - Am9513A Command Register, 4-66
  - Am9513A Counter/Timer Register Group, 4-64 to 4-67
    - programming
      - general considerations, 5-37
      - resource allocation
        - considerations, 5-1 to 5-2
      - sample counters, 5-17 to 5-20
      - sample-interval counter, 5-16 to 5-17
      - scan interval counter, 5-20 to 5-21
      - update-interval counter, 5-32 to 5-33
      - waveform cycle counter, 5-34
      - waveform cycle interval counter, 5-34 to 5-36
    - resetting after data acquisition operation, 5-23 to 5-24
  - Am9513A Data Register, 4-65
  - Am9513A Status Register, 4-67
  - Analog Input Register Group, 4-31 to 4-40
  - Analog Output Register Group, 4-41 to 4-43
    - analog output voltage *versus* digital code
      - bipolar mode (table), 4-42 to 4-43
      - unipolar mode (table), 4-42
    - formula for voltage output *versus* digital code, 4-42
  - Calibration DAC 0 Load Register, 4-62
  - Calibration DAC 1 Load Register, 4-63
  - Command Register 1, 4-5 to 4-8
  - Command Register 2
    - description, 4-9 to 4-12
    - interrupt programming, 5-43
    - programming digital I/O circuitry, 5-36
  - Command Register 3, 4-13 to 4-19
  - Command Register 4, 4-20 to 4-24
  - CONFIGMEM Register
    - description, 4-35 to 4-40
    - programming multiple-analog input channel configurations, 5-16
    - programming single-analog input channel configurations, 5-15
  - CONFIGMEMCLR Register
    - description, 4-47
    - programming multiple-analog input channel configurations, 5-16
    - programming single-analog input channel configurations, 5-15
  - CONFIGMEMLD Register
    - description, 4-48
    - programming multiple-analog input channel configurations, 5-16
    - programming single-analog input channel configurations, 5-15
  - Configuration and Status Register Group, 4-4 to 4-30
  - DAC Clear Register
    - clearing analog output circuitry, 5-32

- description, 4-56
  - DMA operations, 5-41
  - servicing update requests, 5-36
- DAC Event Strobe Register Group, 4-53 to 4-56
- DAC Update Register, 4-55
- DAC0 Register
  - description, 4-44
  - programming analog output circuitry, 5-25
- DAC1 Register
  - description, 4-45
  - programming analog output circuitry, 5-25
- DAQ Clear Register
  - clearing analog input circuitry, 5-14
  - description, 4-49
  - interrupt programming, 5-43
  - programming DMA operations, 5-41
- DAQ Start Register, 4-50
- description format, 4-3
- Digital Input Register
  - description, 4-69
  - digital I/O circuitry, 3-25
  - programming digital I/O circuitry, 5-36
- Digital I/O Register Group, 4-68 to 4-70
- Digital Output Register
  - description, 4-70
  - overview, 3-25
  - programming digital I/O circuitry, 5-36
- DMA Channel Clear Register, 4-58
- DMATCA Clear Register
  - clearing analog output circuitry, 5-32
  - description, 4-59
  - interrupt programming, 5-43
  - programming DMA operations, 5-41
- DMATCB Clear Register
  - clearing analog output circuitry, 5-32
  - description, 4-60
  - interrupt programming, 5-43
  - programming DMA operations, 5-41
- External Strobe Register, 4-61
- General Event Strobe Register Group, 4-57 to 4-63
- programming considerations, 5-1
- register map, 4-1 to 4-2
- register sizes, 4-3
- RTSI Switch Register Group, 4-71 to 4-73
  - RTSI Switch Shift Register, 4-72
  - RTSI Switch Strobe Register, 4-73
- Single Conversion Register, 4-51
- Status Register 1
  - description, 4-25 to 4-29
  - servicing update requests, 5-36
- Status Register 2, 4-30
- TMRREQ Clear Register
  - clearing analog output circuitry, 5-32
  - description, 4-54
  - DMA operations, 5-41
  - interrupt programming, 5-43
  - servicing update requests, 5-35 to 5-36
- relative accuracy specification
  - analog input, A-4
  - analog output, A-7
- RETRIG\_DIS bit, 4-6
- RSE (referenced single-ended input)
  - description (table), 2-8
  - recommended configuration (table), 2-22
  - single-ended connections for floating signal sources, 2-27
- RSI bit, 4-72
- RTSI bus clock, CLKMODEB<1..0> bits for selecting, 4-20 to 4-21
- RTSI bus interface circuitry, 3-29 to 3-30
  - block diagram, 3-29
- RTSI bus trigger line, programming, 5-37 to 5-38

RTSI latch, 3-19

RTSI switch

- definition, 3-30
- programming, 5-39 to 5-43
  - control pattern (figure), 5-40
  - DMA operations, 5-41 to 5-42
  - interrupts, 5-43
- selecting internal update counter, 5-32
- signal connections
  - description, 3-30
  - programming considerations, 5-37 to 5-39
  - signals (table), 5-38

RTSI Switch Register Group, 4-71 to 4-73

- register map, 4-2
- RTSI Switch Shift Register, 4-72
- RTSI Switch Strobe Register, 4-73

RTSICLK signal, 3-30

RTSITRIG bit, 4-8

## S

S2 through S0 bits, 5-40

sample counters, programming, 5-17 to 5-20

- sample counts 2 through 65,536, 5-18
- sample counts greater than 65,536, 5-18 to 5-20

sample-interval counter, programming, 5-16 to 5-17

sample-interval timer, 3-9

scan interval, 5-10

scan interval counter, programming, 5-20 to 5-21

scan sequence, 5-10

SCANCLK signal

- description (table), 2-18, B-5
- multiple-channel data
  - acquisition, 3-12, 3-13
- timing connections, 2-33
- timing I/O circuitry, 3-29

SCANDIV bit

- description, 4-6
- programming multiple-analog input channel configurations, 5-15

SCANEN bit

- continuous channel scanning data
  - acquisition, 5-11
- description, 4-7
- interval-channel scanning data
  - acquisition, 5-14

SCLK bit, 4-5 to 4-6

SCN2 bit

- description, 4-7
- interval-channel scanning data
  - acquisition, 5-14

SDATA bit, 4-5

signal connections

- analog input, 2-19 to 2-20
- analog input configurations
  - common-mode signal rejection, 2-29
  - differential connections
    - DIFF input configuration, 2-22
  - floating signal sources, 2-24 to 2-26
  - ground-referenced signal sources, 2-23
  - nonreferenced signal sources, 2-24 to 2-26
- input modes, 2-7 to 2-11
  - available modes (table), 2-8
  - DIFF input, 2-8
  - NRSE input, 2-9 to 2-10
  - RSE input, 2-9
- recommended configuration (table), 2-22
- single-ended connections, 2-26 to 2-27
  - floating signal sources (RSE configuration), 2-27
  - grounded signal sources (NRSE configuration), 2-28



- analog output, 2-29 to 2-30
- digital I/O, 2-31 to 2-32
- field wiring considerations, 2-42 to 2-43
- I/O connector
  - exceeding maximum ratings (warning), 2-14
  - pin assignments
    - 50-pin connector (figure), 2-15, B-2
    - 68-pin connector (figure), 2-16, B-3
- power connections, 2-32 to 2-33
- RTSI switch, 5-37 to 5-39
- signal descriptions (table), 2-17 to 2-19, B-4 to B-6
- timing connections, 2-33 to 2-42
  - counter signal connections, 2-37 to 2-42
  - data acquisition timing connections, 2-33 to 2-42
  - EXTCONVERT\* signal, 2-34
  - EXTGATE\* signal, 2-36
  - EXTSTROBE\* signal, 2-33
  - EXTTMRTRIG\* signal, 2-36
  - EXTTRIG\* signal, 2-35
  - SCANCLK signal, 2-33
- types of signal sources, 2-21
  - floating, 2-21
  - ground-referenced, 2-21
- Single Conversion Register, 4-51
- single conversions, programming
  - flow chart, 5-6
  - generating single conversions, 5-6
  - reading single conversion result, 5-7
  - using SCONVERT or EXTCNV\* signal, 5-5 to 5-6
- single-analog input channel, programming, 5-15
- single-channel data acquisition timing, 3-9 to 3-12. *See also* data acquisition programming.
  - posttrigger data acquisition timing, 3-10 to 3-11
  - pretrigger data acquisition timing, 3-11 to 3-12
  - programming sequence, 5-7 to 5-9
  - sample-interval timer, 3-9
  - specifications, A-4
- single-ended connections
  - description, 2-26 to 2-37
  - floating signal sources (RSE), 2-27
  - grounded signal sources (NRSE), 2-28
  - when to use, 2-26
- single-read timing, 3-8 to 3-9
- software programming choices
  - ComponentWorks, 1-4
  - LabVIEW and LabWindows/CVI, 1-4
  - NI-DAQ driver software, 1-5 to 1-6
  - register-level programming, 1-6
  - VirtualBench, 1-5
- SOURCE, OUT, and GATE timing signals
  - counter signal connections, 2-37 to 2-42
  - RTSI bus interface circuitry, 3-30
  - timing I/O circuitry, 3-27 to 3-29
- SOURCE1 signal (table), 2-18, B-5
- SOURCE5 signal (table), 2-18, B-6
- specifications
  - Am9513A System Timing Controller, C-33 to C-38
  - analog data acquisition rates, A-4 to A-6
  - analog input, A-1 to A-4
  - analog output, A-6 to A-8
  - digital I/O, A-8
  - operating environment, A-9
  - physical characteristics, A-9
  - power requirements, A-9
  - storage environment, A-9
  - timing I/O, A-8
- SRC3SEL bit
  - description, 4-23 to 4-24

- programmed cycle waveform generation, 5-30
- pulsed cyclic waveform generation, 5-32
- STARTDAQ Register, 3-28
- Status Register 1
  - description, 4-25 to 4-29
  - servicing update requests, 5-36
- Status Register 2, 4-30
- storage environment specifications, A-9
- straight binary mode A/D conversion values (table), 4-33
- switch settings. *See* base I/O address selection.
- system noise, A-4

## T

- technical support, D-1 to D-2
- telephone and fax support, D-2
- theory of operation
  - analog input circuitry, 3-6 to 3-8
    - A/D converter, 3-6
    - ADC FIFO buffer, 3-7
    - block diagram, 3-5
    - input multiplexers, 3-6
    - PGIA, 3-7
  - analog output circuitry, 3-15 to 3-18
    - block diagram, 3-16
    - calibration, 3-17 to 3-18
    - circuitry, 3-16 to 3-17
    - configuration, 3-17
  - AT-MIO-16X block diagram, 3-1
  - DAC waveform circuitry and timing, 3-18 to 3-24
    - FIFO continuous cyclic waveform generation, 3-22 to 3-23
    - FIFO programmed cyclic waveform generation, 3-23
    - FIFO pulsed waveform generation, 3-23 to 3-24
    - waveform circuitry, 3-18 to 3-20
    - waveform timing circuitry, 3-20 to 3-22
  - data acquisition timing circuitry, 3-8 to 3-12
    - block diagram, 3-5
    - data acquisition rates, 3-15
    - multiple-channel data acquisition, 3-12 to 3-15
    - single-channel data acquisition, 3-9 to 3-12
    - single-read timing, 3-8 to 3-9
  - digital I/O circuitry, 3-24 to 3-25
  - functional overview, 3-1 to 3-2
  - PC I/O channel interface circuitry, 3-2 to 3-5
  - RTSI bus interface circuitry, 3-29 to 3-30
  - timing I/O circuitry, 3-25 to 3-29
- time-lapse measurements, 2-38
- timing circuitry. *See* data acquisition timing circuitry; timing I/O circuitry.
- timing connections, 2-33 to 2-42
  - counter signal connections, 2-37 to 2-42
  - EXTCONVERT\* signal, 2-34
  - EXTGATE\* signal, 2-36
  - EXTSTROBE\* signal, 2-33
  - EXTTMRTRIG\* signal, 2-36
  - EXTTRIG\* signal, 2-35
  - SCANCLK signal, 2-33
- timing I/O
  - overview, 1-3
  - specifications, A-8
- timing I/O circuitry, 3-25 to 3-29
  - block diagram, 3-26
  - counter block diagram, 3-27
- timing signals, PC I/O channel interface, 3-4
- TMRREQ bit
  - clearing analog output circuitry, 5-32
  - description, 4-27 to 4-28
  - interrupt programming, 5-43
  - servicing update requests, 5-35

**TMRREQ Clear Register**  
 clearing analog output circuitry, 5-32  
 description, 4-54  
 DMA operations, 5-41  
 interrupt programming, 5-43  
 programming DMA operations, 5-41  
 servicing update requests, 5-35 to 5-36

**TMRREQ signal**  
 DAC waveform timing circuitry, 3-20  
 interrupt programming, 5-43  
 servicing update requests, 5-35 to 5-36

**TMRTRIG\* signal**  
 controlled by A4RCV bit, 4-9  
 programming analog output  
 circuitry, 5-25  
 RTSI switch, 3-30  
 servicing update requests, 5-35

trigger, applying, 5-21

two's complement mode A/D conversion  
 values (table), 4-34

## U

unipolar input, 2-10

unipolar mode, analog output voltage *versus*  
 digital code (table), 4-42

unipolar output, 2-12

unpacking AT-MIO-16X, 1-7

update counter, selecting, 5-32

update-interval counter, programming,  
 5-32 to 5-33

## V

VirtualBench software, 1-5

voltage reference calibration, 6-8 to 6-9

## W

waveform generation programming. *See also*  
 DAC waveform circuitry and timing.

clearing analog output circuitry, 5-32

cyclic waveform generation, 5-26 to 5-27

programmed cycle waveform generation,  
 5-28 to 5-30

pulsed cyclic waveform generation,  
 5-30 to 5-32

selecting internal update counter, 5-32

update-interval counter, 5-32 to 5-33

waveform cycle counter, 5-34

waveform cycle interval counter,  
 5-34 to 5-36

servicing update requests,  
 5-35 to 5-36

wiring considerations, 2-42 to 2-43