

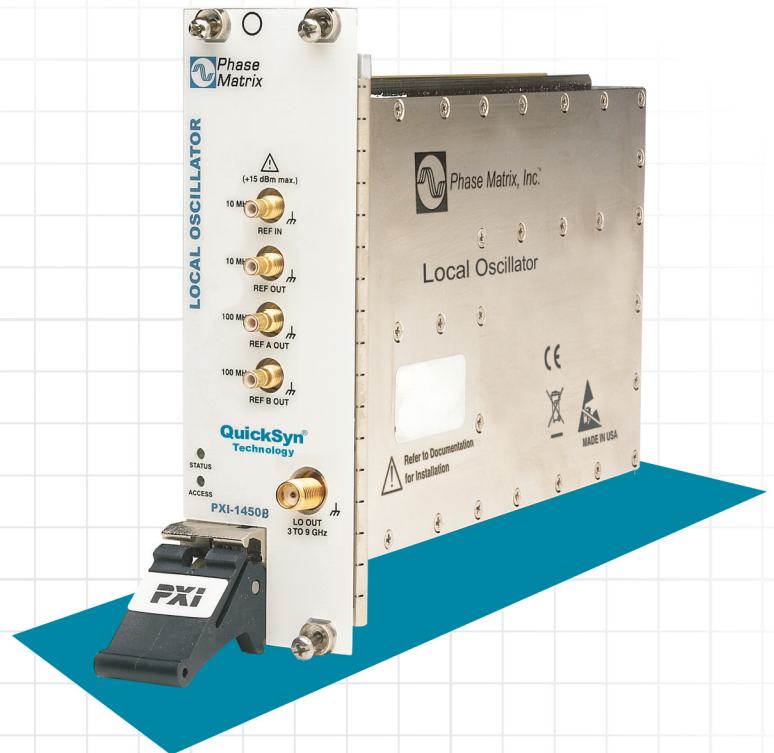

Phase Matrix, Inc.™

PXI MICROWAVE LOCAL OSCILLATOR MODULE

Model PXI-1450B



Quick Start Guide

PXI-1450B CCN 14401

Manual Assy Part Number 5585115-02

Manual Text Part Number 5580115-02 Rev B

Notices

© Phase Matrix, Inc. 2012

No part of this manual may be copied, duplicated, or reproduced in any form or by any means (including electronic storage and retrieval or translation into a foreign language) without prior agreement and written consent from Phase Matrix, Inc. as governed by United States and international copyright laws.

Phase Matrix, Inc.
109 Bonaventura Drive
San Jose, CA 95134

Software Copyright

Original Phase Matrix, Inc. software may be distributed without consent from Phase Matrix, Inc. only if all software and associated files are included in the distribution and remain unmodified.

EIP® is a brand name used to refer to a line of traditional T&M instruments owned by Phase Matrix, Inc.

National Instruments®, NI®, ni.com®, LabVIEW®, and LabWindows® are registered trademarks of National Instruments Corporation.

Microsoft®, Windows®, Vista®, XP®, and 2000® are registered trademarks of Microsoft Corporation.

Warranty

Phase Matrix, Inc. warrants this product to be free from defects in material and workmanship for one year from the date of delivery. Damage due to accident, abuse, or improper signal level is not covered by the warranty. Removal, defacement, or alteration of any serial or inspection label, marking, or seal may void the warranty. Phase Matrix, Inc. will repair or replace, at its option, any components of this product which prove to be defective during the warranty period, provided the entire unit is returned to Phase Matrix, Inc. or an authorized service facility. In-warranty units will be returned freight prepaid; out-of-warranty units will be returned freight COLLECT. No warranty other than the above is expressed or implied.

Certification

Phase Matrix, Inc. certifies this instrument to be in conformance with the specifications noted herein at time of shipment from the factory. Phase Matrix, Inc. further certifies that its calibration measurements are traceable to the United States National Institute of Standards and Technology.

Manual Change Information

As Phase Matrix, Inc. continually improves and updates its products, changes to the material covered by the manual will occur. When a part or assembly in a Phase Matrix, Inc. instrument is changed to the extent that it is no longer interchangeable with the earlier part, the configuration control number (CCN) of the instrument, shown on the title page of the manual, will change, and a new edition of the manual will be published.

To maintain the technical accuracy of the manual, it may be necessary to provide new or additional information with the manual. In these cases, the manual is shipped with a Manual Update. Please be sure to incorporate the information as instructed in the Manual Update.

Safety Notices

CAUTION

A **CAUTION** notice denotes a hazard. It calls attention to an operating procedure, practice, or the like that, if not correctly performed or adhered to, could result in damage to the product or loss of important data. Do not proceed beyond a **CAUTION** notice until the indicated conditions are fully understood and met.

WARNING

A **WARNING** notice defines a hazard. It calls attention to an operating procedure or practice that if not correctly followed or adhered to, could result in either personal injury or death. Do not proceed beyond a **WARNING** notice until the indicated conditions are fully understood and met.



*Phase Matrix, Inc.*TM

Introducing the PXI-1450B Local Oscillator Module

Congratulations on purchasing a
Phase Matrix PXI-1450B Local Oscillator Module!

To get the most out of your purchase, it is recommended that this
[*Quick Start Guide*](#) be read carefully and completely.

In this document...

The scope of this document is to describe the installation process of the stand-alone hardware and software for the PXI-1450B and to confirm basic module operation.

This document describes information for the PXI-1450B when used in a PXI system with an embedded controller or a PXI remote controller.

“Step 1. Confirm Module Operating Requirements” on page 4

“Step 2. Perform Hardware Installation/Configuration” on page 5

“Step 3. Perform Software Installation/Configuration” on page 9

“Step 4. Review Hardware and Soft Front Panels” on page 19

“Step 5. Confirm Basic Module Operation” on page 27

Step 1. Confirm Module Operating Requirements

Table 1 Module Operating Requirements When Used in a PXI System

Operating System

- Windows 7 (32- and 64-bit versions)
- Windows XP (32-bit version)
- LabVIEW Real-Time (Version 8.2.1 and later)

BIOS - computers manufactured prior to 2008 require *NI MXI-Express BIOS Compatibility Software*.

This BIOS software is available on the Internet at: [NI > Support > Drivers and Software > MXI-Express BIOS Compatibility Software - Windows Vista x86/XP](#)

RAM - minimum of 256 MB required by LabVIEW.

CD Drive - used to install PXI device driver software and Soft Front Panel from an optional CD

PXI device driver software and Soft Front Panels are available from an optional CD or from the Phase Matrix web site at: www.phasematrix.com

Screen Resolution - at least 1024 × 768 pixels, recommended.

Adobe Reader - 6.0.1 or later to view or search PDF versions of manuals.

Interface/Controller - select either an embedded controller or a PXI remote controller.

Embedded Controller

NI PXI-8106 2.16 GHz Dual-Core PXI Embedded Controller
or NI PXIe-8106 2.16 GHz Dual-Core PXI Express Embedded Controller
or equivalent embedded controller running Windows 7/XP

PXI Remote Controller

NI PXI-CardBus8310 Laptop Control of PXI with PCMCIA CardBus
or NI PXIe-ExpressCard8360 Laptop Control of PXI Express with ExpressCard
or equivalent PXI remote controller running Windows 7/XP

NOTE

LabVIEW does not support Windows NT/Me/98/95, any of the Windows Server editions, or Windows XP x64.

LabVIEW does support Windows 7 (64-bit version).

LabVIEW or the LabVIEW Run-Time Engine does support Windows 2000 with Service Pack 3 or later.



Phase Matrix, Inc.™

Step 2. Perform Hardware Installation/Configuration

CAUTION

PXI hardware does not support “hot-swap” capabilities!

Before installing the PXI-1450B Local Oscillator Module, the PXI chassis must be powered off and unplugged to prevent damage to PXI modules.

3

The PXI-1450B can be installed in any standard-PXI slot marked with a peripheral slot compatibility image (a circle containing the slot number).

7

The PXI-1450B can also be installed in any hybrid-PXI slot marked with a peripheral slot compatibility image (the letter “H” and a solid circle containing the slot number).

Do not install the PXI-1450B into a slot for PXI Express (PXIe) modules.

NOTE

A PXI-1450B can be used in either a PXI or PXIe chassis, with either a PXI or PXIe interface/controller, but the PXI-1450B must only be installed into a standard-PXI slot or a hybrid-PXI slot.

Step 2-1. Unpack Hardware

PXI-1450Bs ship in antistatic packages to prevent damage from electrostatic discharge (ESD). Because ESD can damage several components of a hardware module, store all modules in antistatic envelopes when not in use.

CAUTION

- To avoid damage when handling a module, do not touch exposed connector pins.
- Before touching or handling a module, use a grounding strap or touch a grounded object to ground yourself.
- Before touching or removing a module from its package, touch the antistatic package to a metal part of your computer chassis.
- Remove each module from its package and inspect it for loose components or any signs of damage. Notify Phase Matrix if any module appears damaged in any way.
- Do not install damaged modules into a system.

Unpack the contents of the box and verify that everything is included:

- PXI-1450B Local Oscillator Module
- Optional CD (included if specifically ordered; otherwise, PXI device driver software and Soft Front Panels are available from the Phase Matrix web site at: www.phasematrix.com).

Step 2-2. Install PXI Modules into a PXI Chassis

Figure 1 Install PXI Modules into a PXI Chassis

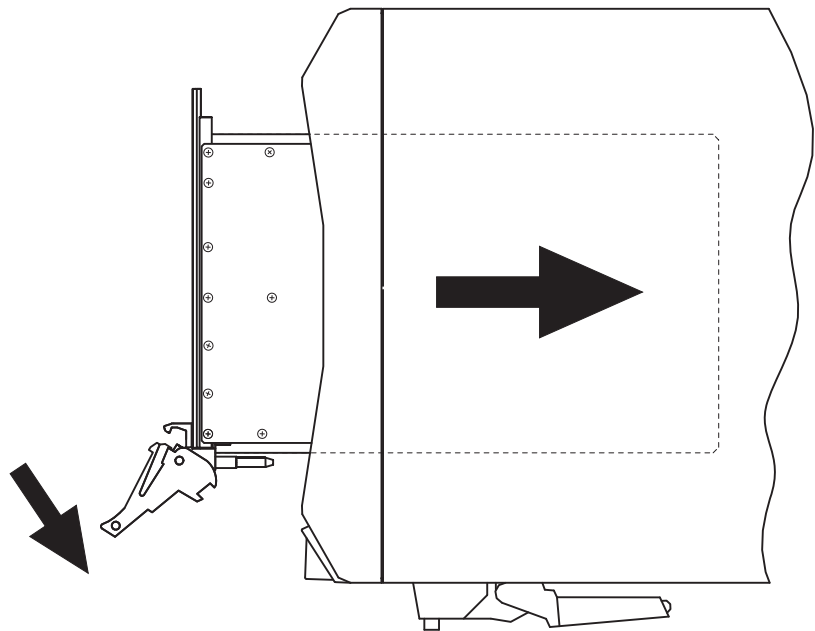

Phase Matrix PXI modules are sensitive instruments that should be handled carefully. Do not expose modules to temperatures or humidity beyond their rated maximums.

CAUTION

- For information about the rated maximums, refer to each module's specifications document available at: www.phasematrix.com
- Keep the module free of dust by cleaning only with compressed air.
- Do not clean the module with any solvents or liquids.
- To prevent damage to the module caused by ESD or contamination, handle the module using the edges or the metal bracket.

- 1 Assure that the power switch is in the Off (Standby) position and unplug the PXI chassis.
- 2 If the chassis has multiple fan speed settings, ensure that the fans are set to automatic. Do not set the fan speed to low or turn it off.
- 3 Position the chassis so that there is ample space between the chassis fan intake and exhaust vents. Blockage by walls or obstructions affects the air flow needed for cooling. (Refer to the chassis documentation for more information about cooling.)
- 4 Holding the PXI-1450B by the injector/ejector handle, slide it into an available PXI (or hybrid) slot, as shown in [Figure 1](#).
 - a Install the PXI-1450B into the PXI (or hybrid) slot of the chassis by placing the module card edges into the front module guides (top and bottom).
 - b Slide the PXI-1450B to the rear of the chassis and assure that the injector/ejector handle is pushed down in the unlatched (downward) position.
 - c Slide the module completely into the chassis. When you begin to feel resistance, push up on the injector/ejector handle to fully inject the module into the chassis frame.
- 5 Latch the PXI-1450B by pulling up on the injector/ejector handle and secure the module front panel to the chassis using the module front-panel mounting screws.
- 6 Tighten the screws on the PXI-1450B front panel. Performance may suffer if the screws are not tightened properly.
- 7 Verify that the PXI chassis fans are operable and free of dust and other contaminants that may restrict airflow.
- 8 Install all chassis covers and filler panels after installing the PXI-1450B. Missing filler panels disrupt necessary air circulation in the chassis.

NOTE

Phase Matrix recommends installing slot blockers in adjacent vacant PXI slots to maximize cooling air flow to the PXI modules.

A PXI Chassis Slot Blocker Kit (National Instruments part number 778678-01) is available for purchase at www.ni.com.

- 9 Plug-in and power-on the PXI chassis.

Step 2-3. Connect to the Host Computer and Power Source

Embedded Controller

- 1 Connect the keyboard, mouse, monitor and any other external devices to the PXI embedded controller.
- 2 Connect the chassis' AC or DC inlet to the power source using an appropriate power cable.
- 3 When the power switch is in the ON position, observe that fans become operational.
- 4 If the power outlet does not have an appropriate ground connection, connect the premise safety ground to the chassis grounding screw. Refer to the chassis' user manual at ni.com/manual for instructions.

PXI systems can be controlled from a PC or laptop computer through a software transparent link using National Instruments' PXI Remote Controllers.

- PC control of PXI consists of a PCI/PCI Express board in the computer and a PXI/PXI Express module in slot 1 of the PXI system, connected by a copper or fiber-optic cable.

- Laptop computer control of PXI consists of an ExpressCard/PCMCIA CardBus card in the laptop and a PXI/PXI Express module in slot 1 of the PXI system, connected by a copper cable.

PXI Remote Controller

- 1 Install the PCI/PCI Express board in a PC or insert the ExpressCard/PCMCIA CardBus card in a laptop computer.
- 2 Connect the chassis' AC or DC inlet to the power source using an appropriate power cable.
- 3 When the power switch is in the ON position, observe that fans become operational.
- 4 If the power outlet does not have an appropriate ground connection, connect the premise safety ground to the chassis grounding screw. Refer to the chassis' user manual at ni.com/manual for instructions.

(Step 2-4. Optional) Uninstall PXI Modules

Before uninstalling PXI modules, power off the PXI chassis!

When removing PXI modules from a chassis, ensure that you are grounded with a grounding strap or are touching a grounded metal surface. To avoid ESD, do not touch the exposed connector pins or any exposed circuitry on the device. When not in use, PXI modules should be stored in the original antistatic envelope to avoid damage.



Phase Matrix, Inc.™

Step 3. Perform Software Installation/Configuration

Complete the following steps to install the PXI device driver software and Soft Front Panel available from an optional CD or from the Phase Matrix web site at: www.phasematrix.com

NOTE

Any application development environment (ADE) that is to be used (such as LabVIEW, LabWindows/CVI, or a third-party program) must be installed prior to installing the PXI device driver software or its Soft Front Panel.

Embedded Controller

- 1 Install the PXI device driver from an optional CD or from the Phase Matrix web site.
See “[Step 3-1. Installing the PXI Device Driver](#)” on page 10.
- 2 Install the Soft Front Panel from an optional CD or from the Phase Matrix web site.
See “[Step 3-2. Installing the Soft Front Panel](#)” on page 13.

PXI Remote Controller

PXI systems can be controlled from a PC or laptop computer through a software transparent link using National Instruments’ PXI Remote Controllers.

- PC control of PXI consists of a PCI/PCI Express board in the computer and a PXI/PXI Express module in slot 1 of the PXI system, connected by a copper or fiber-optic cable.

- Laptop computer control of PXI consists of an ExpressCard/PCMCIA CardBus card in the laptop and a PXI/PXI Express module in slot 1 of the PXI system, connected by a copper cable.

- 1 If the PXI remote controller (PC or laptop computer) being used is a Windows based operating system and was manufactured prior to 2008, install *NI MXI-Express BIOS Compatibility Software*:
[NI MXI-Express BIOS Compatibility Software](#)
- 2 Install the *NI PXI Platform Services Software* that accompanies the PXI remote controller: [NI PXI Platform Services Software](#)
- 3 Install the PXI device driver from an optional CD or from the Phase Matrix web site.
See “[Step 3-1. Installing the PXI Device Driver](#)” on page 10.
- 4 Install the Soft Front Panel from an optional CD or from the Phase Matrix web site.
See “[Step 3-2. Installing the Soft Front Panel](#)” on page 13.
- 5 Connect the PXI remote controller, using the manufacture’s provided cable, to the expansion card in the PXI remote controller.
- 6 Reboot the PXI remote controller.

Step 3-1. Installing the PXI Device Driver

This procedure is used to install the PXI-1450B's device driver using the "Found New Hardware Wizard" on an embedded controller or a PXI remote controller running Windows 7/XP.

NOTE

If the embedded controller or the PXI remote controller being used has previously had a device driver of the same type installed, it must be removed before installing a new PXI-1450B's device driver.

Refer to "(Step 3-3. Optional) Uninstalling the PXI Device Driver" on page 17 for further details.

NOTE

Any application development environment (ADE) that is to be used (such as LabVIEW, LabWindows/CVI, or a third-party program) must be installed prior to installing the PXI device driver software or its Soft Front Panel.

NOTE

The following procedure is shown for systems running Windows 7 and may vary slightly for systems running Windows XP.

NOTE

Anti-virus software may prevent the PXI device driver installer from executing.

1 Install PXI device drivers using one of the following methods:

- Insert the optional CD containing the device driver.
- Download the latest available PXI device driver from the Phase Matrix web site and unzip it to a location on the embedded controller or the PXI remote controller.

Device drivers are available at: www.phasematrix.com

CAUTION

PXI hardware does not support "hot-swap" capabilities!

Before installing the PXI-1450B Local Oscillator Module, the PXI chassis must be powered off and unplugged to prevent damage to PXI modules.

2 Install PXI modules into the PXI chassis and turn on power.

- 3 Launch the PXI-14XX Series Device Driver Installer, “PXI-14XX Driver (32 bit).exe” or “PXI-14XX Driver (64 bit).exe.”

The PXI-14XX Series Device Driver Installer will open with a welcome window similar to the one shown in [Figure 2](#).

Figure 2 Example Welcome Window



- 4 Select **Next** to continue.

Windows will display the End User License Agreement (EULA) as shown in [Figure 3](#).

Figure 3 Example of Software License Agreement

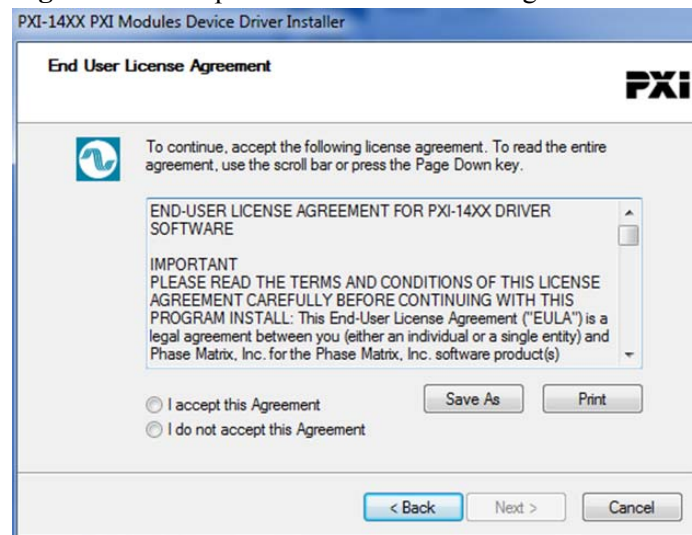

5 Carefully read through the EULA.

- If you accept the terms of the EULA, select “I accept this Agreement” and select **Next** to continue.
- If you do not accept the agreement, you will not be able to install the software.

A Windows security window similar to the one shown in [Figure 4](#) will appear.

Figure 4 Example of Windows Security Window

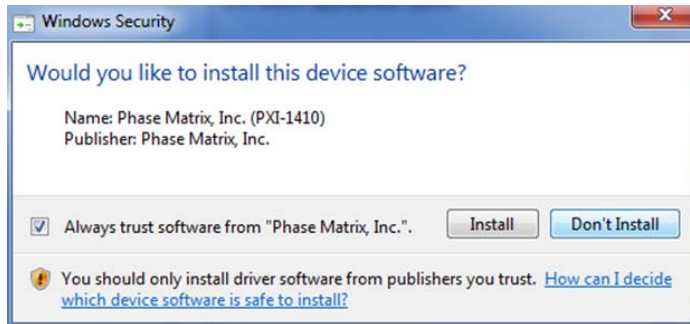

6 Select **Install** to continue.

Windows should display a message indicating that the installation was successful.

Figure 5 Example of Completing the Installer



7 Select **Finish** to complete the device driver installation.

Step 3-2. Installing the Soft Front Panel

This procedure is used to install the PXI-1450B's Soft Front Panel graphical user interface on an embedded controller or a PXI remote controller running Windows 7/XP.

NOTE

The device driver software must be installed before this Soft Front Panel can be used to control the PXI-1450B.

Refer to “[Step 3-1. Installing the PXI Device Driver](#)” on page 10 for further details.

NOTE

Any application development environment (ADE) that is to be used (such as LabVIEW, LabWindows/CVI, or a third-party program) must be installed prior to installing the PXI device driver software or its Soft Front Panel.

NOTE

The following procedure is shown for systems running Windows XP and may vary slightly for systems running Windows 7.

- 1 Install the Soft Front Panel using one of the following methods:
 - Insert the optional CD containing the Soft Front Panel.
 - Download the latest available Soft Front Panel from the Phase Matrix web site and unzip it to a location on the embedded controller or the PXI remote controller.

Soft Front Panels are available at: www.phasematrix.com

- 2 Start the installation process by selecting **Start > Run > Browse**, navigate to the "setup.exe" file and select **Open** to start the installation wizard.

After a small delay, a screen similar to [Figure 6](#) is displayed. The actual screen that appears will have the label of the module Soft Front Panel being installed, so instead of “PXI-14XX,” the label is

displayed as either “PXI-1410,” “PXI-1420,” “PXI-1430B,” “PXI-1440,” or “PXI-1450B.”

Figure 6 Example of Starting the Soft Front Panel Installation Wizard

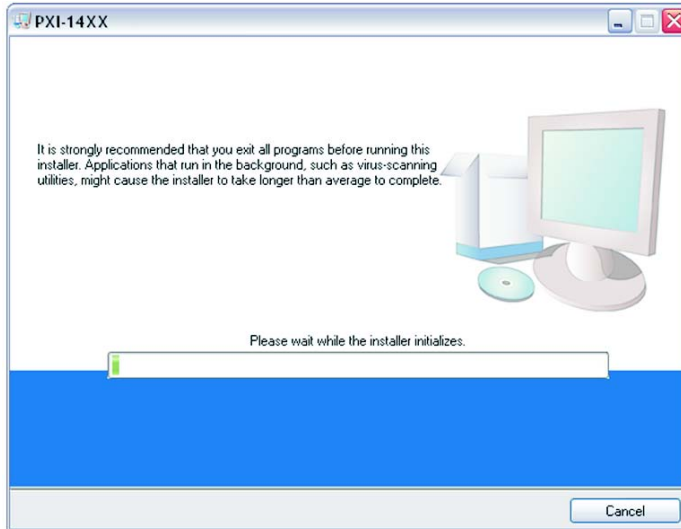

3 Continue to the next screen.

Figure 7 Example of Selecting Destination Directory for Executables

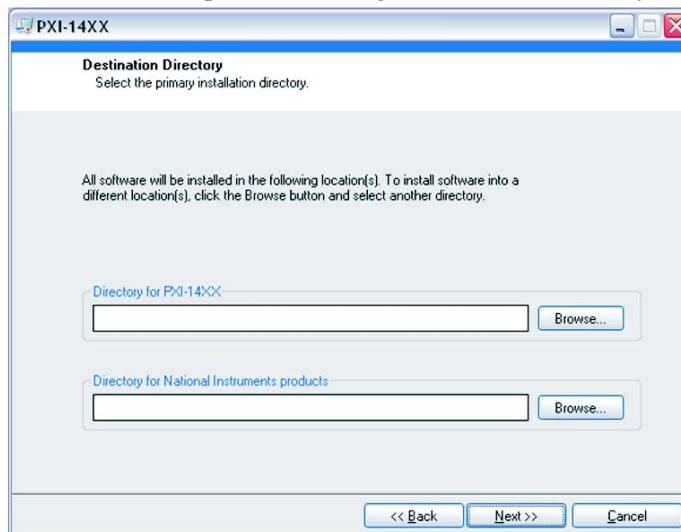

- 4 Enter the destination directory for the PXI-1450B’s Soft Front Panel executables or browse to a destination directory by selecting the **Browse** button.
- 5 Once the file path has been entered, select **Next** to continue to the Software License Agreement.

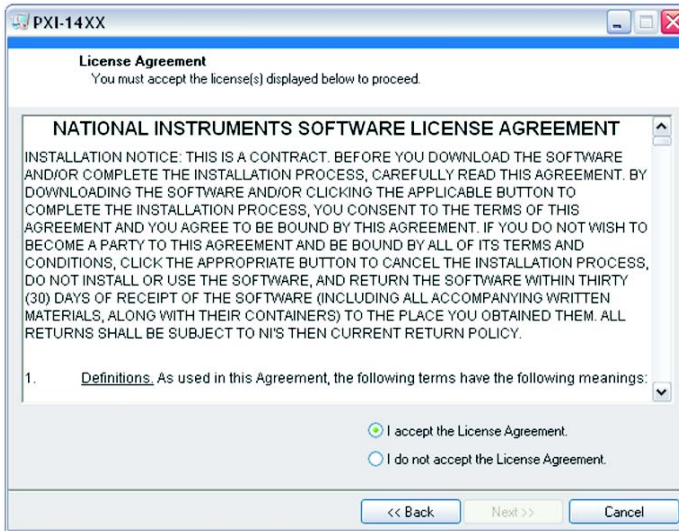
Figure 8 Example Software License Agreement

- 6 Carefully read through the Software License Agreement.
 - If you agree to the terms of the software license agreement, select "I accept the License Agreement" and select **Next** to continue.
 - If you do not agree, you will not be able to install the software.

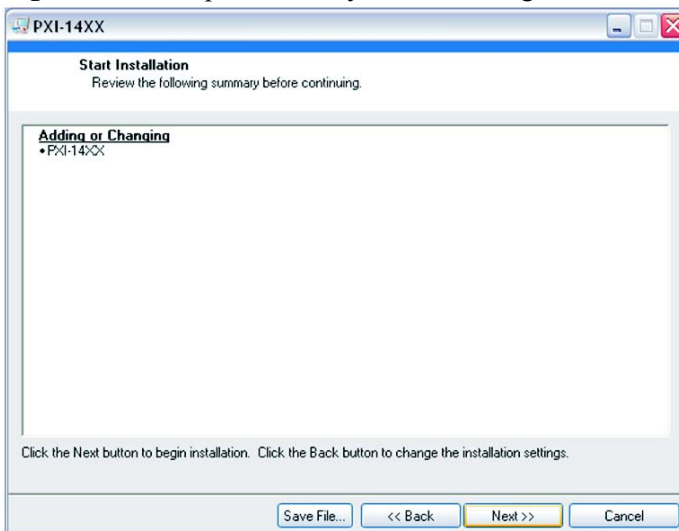
Figure 9 Example Summary of Files Being Installed

- 7 Review the list of files to be installed and select **Next** to begin the installation.

Figure 10 Example of Completing Soft Front Panel Installation Wizard

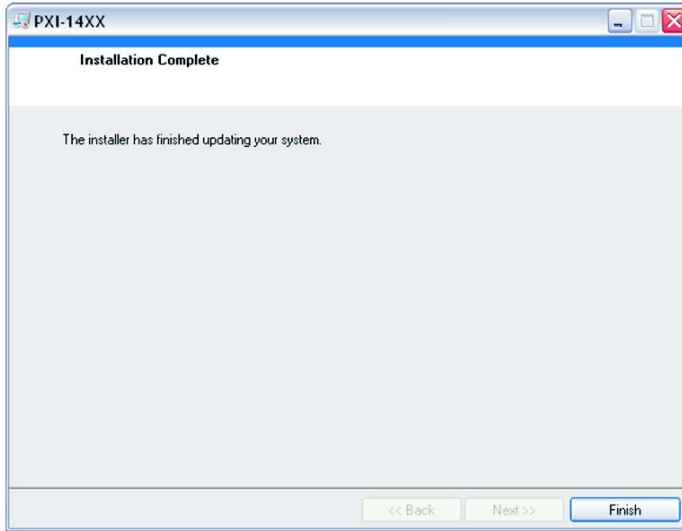

8 Select **Finish** to complete the Soft Front Panel installation.

(Step 3-3. Optional) Uninstalling the PXI Device Driver

This procedure is used to uninstall previous versions of the PXI-1450B's device driver from an embedded controller or a PXI remote controller running Windows 7/XP.

NOTE

- If this is the first time that a PXI-1450B's device driver is being installed, this procedure is optional and can be skipped.
- If the embedded controller or the PXI remote controller has previously had a device driver of the same type installed, it must be removed before installing a new PXI-1450B's device driver.

NOTE

The following procedure is shown for systems running Windows XP and may vary slightly for systems running Windows 7.

Figure 11 Example of Device PX14XX Under "NI-VISA PXI Devices"

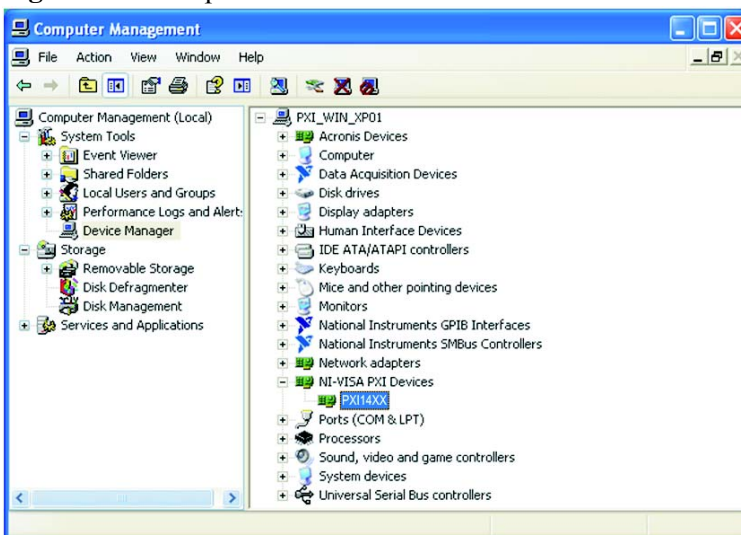

- 1 Open the Device Manager by selecting **Start > Control Panel > Performance and Maintenance > System**.
- 2 Select the **Hardware** tab and select **Device Manger**.
- 3 Select the **View** pull-down menu.
- 4 Select **Devices by connection** and the device should appear under "NI-VISA PXI Devices" with the label as "PM14XX."*

* PM14XX will actually display as PXI-1450B Local Oscillator Module.

- 5 To uninstall the device driver for a selected module, right-click on the selected device and a popup menu is displayed with five selectable choices.
- 6 Select **Uninstall** and a popup window is displayed with a conformation to continue with the uninstall process.

Figure 12 Example of Confirming Device Driver Removal



- 7 Select **OK** to confirm the prompt and uninstall the device driver.



Step 4. Review Hardware and Soft Front Panels

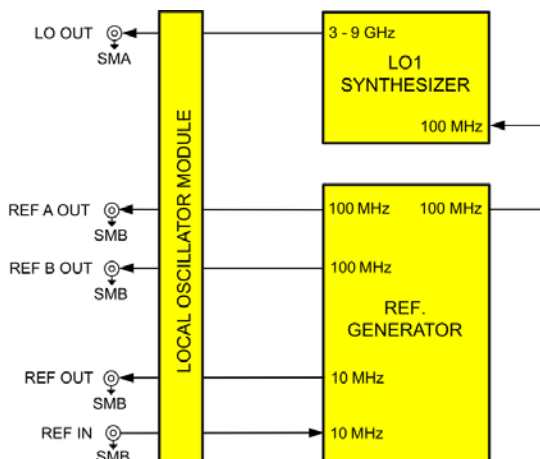
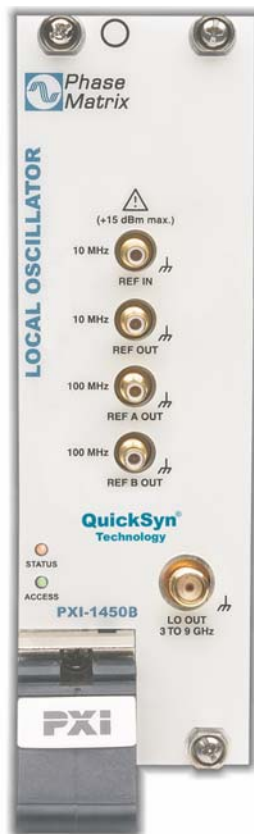

Hardware Front Panel

Figure 13 Hardware Front Panel of the PXI-1450B Local Oscillator Module

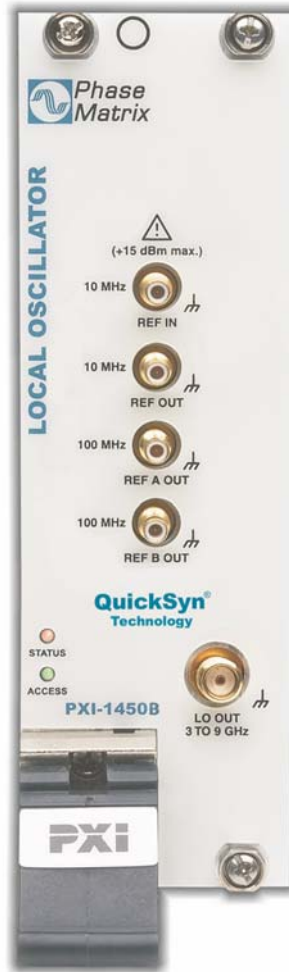

CAUTION

The maximum power input to the 10 MHz REF IN connector must not exceed +15 dBm!

STATUS LED This LED indicates the overall health of the PXI-1450B. This includes the power supplies and other hardware.

The PXI-1450B has extensive built-in-test (BIT). Additional insight can be learned by reading the status section of the Soft Front Panel.

The STATUS LED can have four possible conditions:

- **Green** indicates that all power supplies are functioning within their tolerances and all hardware is functioning.
- **Amber** indicates that all power supplies are functioning within their tolerances, but there is a hardware failure or no reference clock is present.
- **Red** indicates a failure in the power supplies and module hardware. This can be a catastrophic failure.
- **Off** indicates a failure in the power supplies, but module hardware seems to be functioning. Module hardware functioning indication can be erroneous in this mode since this circuitry can be compromised by a power supply failure.

ACCESS LED This Solid AMBER LED blinks to indicate each time the module is written to or read from.

REF IN 10 MHz SMB (m) connector is used to supply 10 MHz reference input to the front panel.

REF OUT 10 MHz SMB (m) connector is used to supply 10 MHz reference out from the front panel.

REF A/B OUT 100 MHz SMB (m) connectors are used to supply 100 MHz reference out from the front panel. These 100 MHz reference signals are phase coherent with the 10 MHz reference being used.

LO OUT SMA (f) connector is used to deliver the local oscillator signal (3 GHz to 9 GHz) out of the front panel.

Soft Front Panel

Control Tab

Figure 14 Control Tab



Serial Number, Soft Front Panel, Last Cal Date, and FPGA Date Code shown in the top-right corner of the Soft Front Panel is information about the PXI module being controlled by this Soft Front Panel. This information cannot be changed through the Soft Front Panel.

Stop Button This button is used to stop the Soft Front Panel from reading and writing to the PXI module; it halts the program and is the preferred way to exit the program.

REF OUT 10 MHz These selection buttons are used to select between REF OUT and MUTE.

- When REF OUT is selected, the 10 MHz reference is output to the REF OUT 10 MHz front panel connector.
- When MUTE is selected, the REF OUT 10 MHz reference signal is disabled.

REF A/B OUT 100 MHz These selection buttons are used to select between 100 MHz REF A/B OUT and MUTE.

- When REF A/B OUT is selected, the 100 MHz reference is output to the REF A OUT 100 MHz and REF B OUT 100 MHz front panel connectors.
- When MUTE is selected, the REF A OUT 100 MHz and REF B OUT 100 MHz signals are disabled.

LO OUT Power These selection buttons are used to select between LO OUT ON and MUTE.

- When LO OUT ON is selected, the LO frequency and output power are output to the LO OUT 3 to 9 GHz front panel connector.
- When MUTE is selected, the LO OUT 3 to 9 GHz signal is disabled.

LO OUT Frequency This rotary control (along with an entry box) is used to select the LO output frequency and may be changed by pointing to the rotary control and dragging it around to the left or right so that the rotary control turns and selects different frequency values; the corresponding selected value of LO output frequency is displayed in the entry box below the rotary control. The entry box value may be changed by highlighting the numbers and entering the change or by using the up/down buttons to the left of the entry box. Values can be changed from 3 GHz to 9 GHz.

Status The Status LEDs described in [Table 2](#) display green when the module is functioning properly. A red LED indicated the module is not communicating with the PXI bus.

Table 2 Soft Front Panel, LOM Control, Status LEDs

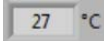
Indicator	Description
+5Volts	+5 V power supply displays green when functioning and is within tolerance.
+12Volts	+12 V power supply displays green when functioning and is within tolerance.
+3Volts	+3 V power supply displays green when functioning and is within tolerance.
-12Volts	-12 V power supply displays green when functioning and is within tolerance.
Ref Detect	Displays green when a reference signal is detected at REF IN on the front panel.
Ref Lock	Displays green when the internal reference is locked to the external reference signal applied at REF IN.
Locked	Displays green when the LO signal has settled and indicates that the final output is locked; this is an AND function of the three internal synthesizers (RBASE, VBASE, and DCELP).
BUSY	Displays green when the PXI Interface is BUSY writing commands to the internal hardware. No other commands should be sent to this PXI module while BUSY is active
	For factory use only.
	This number indicates the internal real-time ambient temperature of the module in degrees Celsius.

Cal Data Tab

Figure 15 Cal Data Tab



The Cal Data tab displays data that is stored in the module hardware. This data is loaded at the factory during initialization and calibration.

The upper portion of this tab displays unit information such as model number, serial number, configuration-control number, FPGA part number, EEPROM part number, and last calibration date.



*Phase Matrix, Inc.*TM

Step 5. Confirm Basic Module Operation

Purpose of Confirmation

The purpose of this process is to confirm the basic module operation of the PXI-1450B.

Confirmation Requirements

The PXI-1450B is confirmed by measuring the output frequency with a Microwave Frequency Counter at a sampling of frequencies as follows:

- 3 GHz
- 4 GHz
- 5 GHz
- 6 GHz
- 6.000000010 GHz
- 6.000000100 GHz
- 6.000001000 GHz
- 7 GHz
- 8 GHz
- 9 GHz

This process confirms that all connectors, switches, cables, and related circuitry used in these signal paths are functional.

Equipment Requirements

Figure 16 shows a block diagram of the equipment setup with the type of equipment (or equivalent performance) required to confirm basic module operation.

Table 3 Equipment Requirements to Confirm Basic Module Operation

Qty	Type	Description
1	Phase Matrix 25B	Microwave Frequency Counter
1	10 dB Attenuator	
1	NI PXIe-1065	PXI chassis
1	NI PXI-8106	PXI Embedded Controller with Windows 7/XP
1		Display

Equipment Setup to Confirm Basic Module Operation

Figure 16 Equipment Setup to Confirm Basic Module Operation

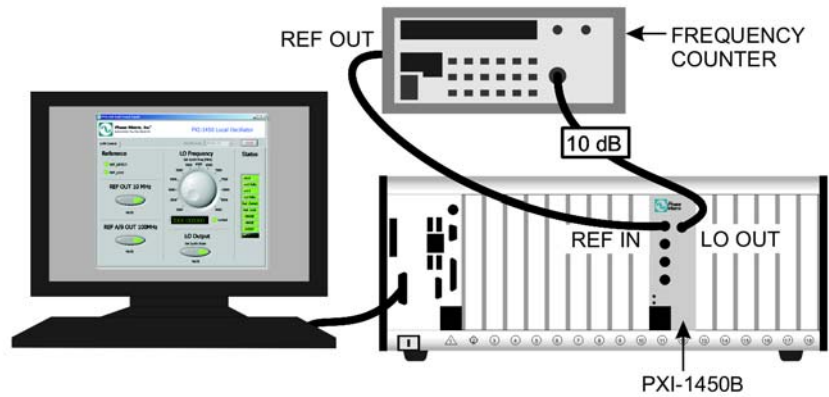

- 1 Connect the equipment as shown in Figure 16.

The output of the PXI-1450B Local Oscillator Module is connected to the appropriate frequency range input of the Microwave Frequency Counter.

To reduce damages from over power, insert a 10 dB attenuator on the input of the Microwave Frequency Counter.

- 2 To reduce time base errors from the measurements, connect the internal time base REF OUT of the Microwave Frequency Counter

to the REF IN 10 MHz of the PXI-1450B.

- 3 Check that the REF DETECT indicator on the PXI-1450B's Soft Front Panel is indicating that the external 10 MHz is detected.

Check that the REF_LOCK indicator on the PXI-1450B's Soft Front Panel is indicating that the external 10 MHz is locked.

For a description of REF DETECT, see the section about "[REF A/B OUT 100 MHz](#)" on page 23.

- 4 Using the Soft Front Panel of the PXI-1450B, adjust the LO frequency to a desired test frequency and enable the LO OUTPUT.
- 5 The Microwave Frequency Counter should display:
set frequency \pm spec \pm Microwave Frequency Counter resolution
- 6 Repeat this process for each desired test frequency.

If a Problem Occurs

If a problem occurs, perform the following checks before returning a PXI module for repair:

- 1 Check that all system components are powered on:
 - PXI mainframe
 - PXI-1450B Local Oscillator Module
 - Microwave Frequency Counter
- 2 Check that both the PXI-1450B and the Microwave Frequency Counter are tuned to the same frequency, and that the cable connections are properly made. (Refer to [Figure 16](#).)
- 3 Check that the STATUS LED is Green, refer to [page 21](#).
- 4 Check that the ACCESS LED switches each time that a path is selected, refer to [page 21](#).
- 5 Contact Phase Matrix Customer Support for additional help.

Service Information

Periodic Maintenance

No periodic preventive maintenance is required. There are no hardware adjustments within the PXI-1450B.

Phase Matrix recommends that the PXI module is calibrated every 12 months or whenever a problem is suspected. The specific calibration interval depends upon the accuracy required.

PXI Module Identification

Each PXI module is identified by three sets of numbers: the model number (PXI-1450 is shown in this example), a configuration-control number (CCN), and a serial number (S/N).

These numbers are located on a label affixed to the frame on the side of the PXI-1450B (some units may have separate CCN and serial-number labels). The model number, CCN, serial number, and the numbers of any options must be included in any correspondence regarding your PXI module. A typical serial-number label is shown in [Figure 17](#).

Figure 17 Example of a Label Affixed to the Side of the PXI Module

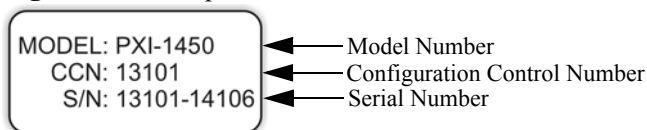

Factory Service

If you are returning a PXI module to Phase Matrix for service or repair, be sure to include the following information with the shipment:

- Name and address of owner.
- Model, complete serial number, and CCN of the PXI module.
- A complete description of the problem. Be sure to provide enough information so that the problem can be verified:
 - Under what conditions did the problem occur?
 - Did the unit work and then fail?
 - What other equipment was connected to the PXI module when the problem occurred?
- The name and telephone number of someone familiar with the problem who can be contacted by Phase Matrix if any further information is required.
- The shipping address to which the PXI module is to be returned. Include any special shipping instructions.

Shipping Instructions

- 1 Place the PXI module in an antistatic bag or enclosure.
- 2 Wrap the PXI module in heavy plastic or kraft paper.
- 3 Repack the PXI module in the original container, if available.

If the original container cannot be used, pack the PXI module in a heavy (275 pound test) double-walled carton with approximately four inches of packing material between the PXI module and the inner carton.

- 4 Seal the carton with strong filament tape or strapping.
- 5 Mark the carton to indicate that it contains a fragile electronic instrument.
- 6 Ship the PXI module to Phase Matrix at the following address:

Phase Matrix, Inc.
109 Bonaventura Dr.
San Jose, CA 95134
Tel: 1-408-428-1000
www.phasematrix.com