

---

# PCIe-8371

# Features

---

2024-06-25



# Contents

PCIe-8371 .....	3
Functional Overview .....	5
Getting Started .....	9
Installation and Configuration.....	12
PCIe-8371 (199994x-01L) LEDs.....	18
Software Installation and Configuration .....	19
Common Questions .....	20

# PCIe-8371

This manual describes the features, functions, and operation of the PCIe-8371.

## Electromagnetic Compatibility Guidelines

This product was tested and complies with the regulatory requirements and limits for electromagnetic compatibility (EMC) as stated in the product specifications. These requirements and limits are designed to provide reasonable protection against harmful interference when the product is operated in its intended operational electromagnetic environment. There is no guarantee that interference will not occur in a particular installation. To minimize the potential for the product to cause interference to radio and television reception or to experience unacceptable performance degradation, install and use this product in strict accordance with the instructions in the product documentation.

The following statements contain important information needed before installing and using this product:



**Caution** This product is intended for use in industrial locations. As a result, this product may cause interference if used in residential areas. Such use must be avoided unless the user takes special measures to reduce electromagnetic emissions to prevent interference to the reception of radio and television broadcasts.



**Caution** Changes or modifications not expressly approved by National Instruments could void the user's authority to operate the hardware under the local regulatory rules.



**Caution** For EMC compliance, operate this device with shielded cables and accessories.

## Description and Features

MXI-Express x4 uses PCI Express signals over a cable of up to 7 m with PCI Express-to-PCI Express switches. You can do the following with MXI-Express x4:

- Control a PXI Express or CompactPCI Express backplane with a PCI Express-based PC
- Physically separate the measurement or automation system from a host PC
- Control multiple PXI Express or CompactPCI Express chassis with a single PCI Express-based PC or PXI Express embedded controller.

The following table lists the products and lists their features for comparison.

**Table 1.** Feature Comparison of Available MXI-Express x4 Interfaces

Model	Slot Type	Number of Ports	Cable Support
PCIe-8371	PCI Express x4	1	MXI-Express x4 Copper
PCIe-8372	PCI Express x4	2	MXI-Express x4 Copper
PXIe-8370	PXI Express Controller	1	MXI-Express x4 Copper
PXIe-8374	PXI Express Peripheral	1	MXI-Express x4 Copper



**Note** There are other products not listed in the table above that support MXI-Express x4 connectivity, such as the HDD-826X series of products. For installation instructions and other information concerning these products, refer to their respective manuals.

# Functional Overview

MXI-Express x4 is based on PCI Express technology. A MXI-Express x4 kit uses PCI Express switches to enable control of a PXI Express or CompactPCI Express chassis from a PC with an available PCI Express slot, or from a PXI Express chassis with an available PXI Express slot. The switch architecture is transparent to device drivers, so no additional software is needed for CompactPCI Express level support for PXI Express devices in connected chassis.



**Note** For full PXI/PXI Express functionality such as chassis and controller identification, trigger routing, and slot detection, install the PXI Platform Services software included with your kit. You also can find this software at [ni.com/updates](http://ni.com/updates) by searching for **PXI Platform Services**.

The link between the PC and the chassis is a x4 cabled PCI Express link. This link is a dual-simplex communication channel comprised of four low-voltage, differentially driven signal pairs. The link can transmit at a rate of 10 Gbps in each direction simultaneously.



**Note** This port is compatible with the cabled PCI Express specification developed by the PCI-SIG.

The BIOS of some host machines may not support the extension of the PCI-Express fabric or PCI bus. Because this is the primary function of MXI-Express x4 products, those systems may not boot or function correctly. To address this issue, certain MXI-Express x4 products have additional functionality intended to hide all PCI or PCI-Express resources that are connected to the host machine, and allow NI MXI-Express BIOS Compatibility Software to handle the enumeration process of these resources instead of the BIOS.

In the cases where this software is required, there may be a dip switch on the board that needs to be toggled as instructed by the documentation for the software. The functional block diagram illustrates the location and availability of the dip switch

package. Only the first dip switch in the package is used for this purpose. The other switches serve no function and should be left in their default position. <sup>[1]</sup>



**Note** Unless NI MXI-Express BIOS Compatibility Software is installed on the host machine for use, the BIOS Compat Mode dip switch (switch 1) should remain in the off position. If this mode is enabled on a MXI-Express x4 product in a host machine that does not have the software installed, the operating system will not detect connected devices.

## PCIe-8371 Overview

With the PCIe-8371, you can control PXI Express and CompactPCI Express systems from a x4 or higher PCI Express slot in your desktop or server PC.

The PCIe-8371 includes one x4 PCI Express link that provides up to 798 MB/s of sustained throughput when cabled to a single PXI Express chassis. The PXIe-PCIe-8371 kit consists of an PCIe-8371 in the PC connected via a x4 MXI-Express cable to a PXI Express module in slot 1 of a PXI Express chassis.

## PCIe-8371 Block Diagram

Figure 1. PCIe-8371 (199994x-01L) Block Diagram

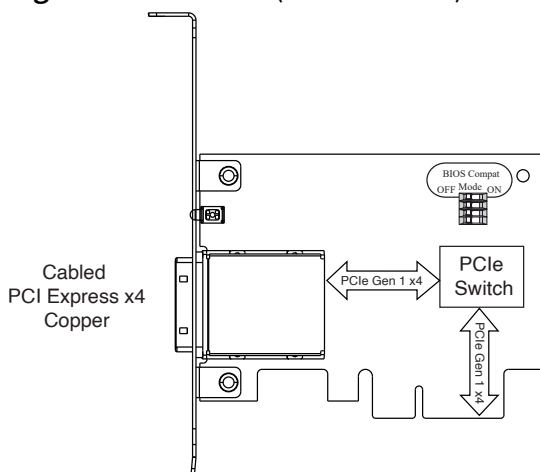

## Basic MXI-Express x4 System

The simplest MXI-Express x4 system consists of a PCIe-8371/8372 in a PC connected to a PXIe-8370 in the controller slot of a PXI Express chassis, as shown in the following

figure.

**Figure 2.** Example of a Basic MXI-Express x4 Link Topology

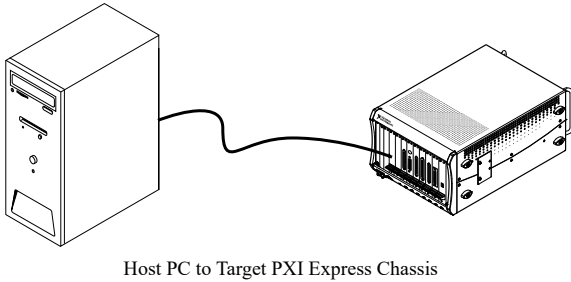

Host PC to Target PXI Express Chassis

## Larger MXI-Express x4 Systems

The PCIe-8372 has two MXI-Express x4 connectors, allowing one PCIe-8372 to host two different PXIe-8370 cards in separate PXI Express or CompactPCI Express chassis. If multiple PCI Express slots are available in the host PC, you can connect additional PXI Express chassis by installing an additional PCIe-8371/8372 in any available PCI Express slot.

You can also daisy-chain from a PXI Express chassis already controlled by an embedded controller, host PC, or laptop to additional PXI Express chassis using MXI-Express x4 products.

The following figures show how you can use MXI-Express x4 cards to connect multiple PXI Express expansion chassis to a PC in a star or daisy-chain topology.

**Figure 3.** Example of MXI-Express x4 Star Topology

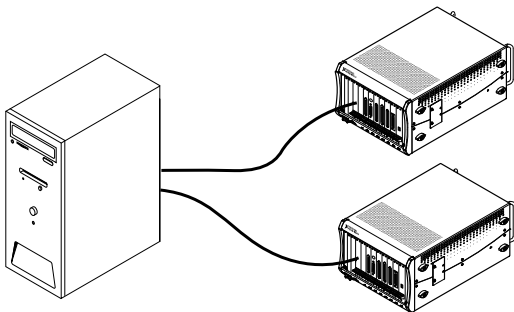

**Figure 4.** Example of MXI-Express Daisy-Chain Topology

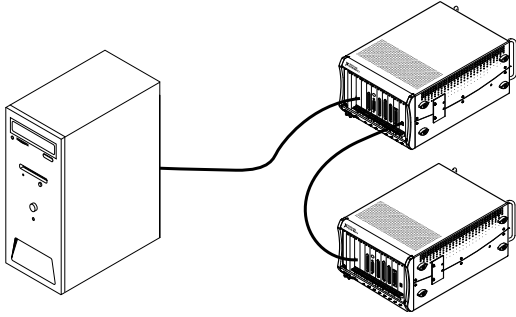



# Getting Started

This section explains what you will need to set up various MXI-Express x4 hardware configurations.

The products covered by this guide are the PCIe-8371/8372 and PXIe-8370/8374. For the remainder of this manual, the term **MXI-Express x4 product** refers to any of these products.

Additional compatible products are included in subsequent tables, but are not covered in this manual.

## Terminology

The following terms may be used throughout this document:

- Host PC—A host computer with at least one PCI Express x4 or wider slot available.



**Note** Using a PCI Express slot wider than x4 may result in negotiation down to x1 width, and therefore limiting bandwidth. This is uncommon in newer PCs.

- Expansion Chassis—An expansion chassis of any of the following types:
  - CompactPCI Express chassis
  - PXI Express chassis
  - NI HDD RAID
- MXI-Express x4 copper cable—Standard PCI Express specification-compliant cable with x4 PCI Express connectors.



**Note** Refer to the **Cabling** section for details. Most MXI-Express kits include the cable, but not all.

- Host Board—The MXI-Express x4 board of a cabled pair of boards that is closer to the CPU.

- Target Board—The MXI-Express x4 board of a cabled pair of boards that is farther from the CPU.
- Cabled Pair—Two MXI-Express x4 boards that are connected with a single cable.

## Connecting a PC to an Expansion Chassis

### Using a MXI-Express x4 Copper Cable

Refer to the **Terminology** section for more detail on the items in this list.

#### Equipment Needed

- Host PC
- Expansion chassis
- MXI-Express x4 copper cable
- A MXI-Express x4 host board and target board that is appropriate for the host system slot and target chassis. Refer to the following table for more information.

From Host	Targets				
Slot Type	Product	PXI Express Chassis	HDD RAID		
		PXIe-8370	HDD-8263	HDD-8264	HDD-8265
PCI Express x4	PCIe-8371	✓	✓	✓	✓
PCI Express x4	PCIe-8372	✓	✓	✓	✓

Note: For installation instructions and other information about the NI HDD series of products, refer to their respective user manuals.



**Note** For full PXI or PXI Express functionality, refer to the **Software Installation and Configuration** section.

# Connecting Additional Expansion Chassis to a System

## Using a MXI-Express x4 Copper Cable

Refer to the **Terminology** section for more detail on the items in this list.

### Equipment Needed

- Chassis to daisy-chain from
- Expansion chassis to daisy-chain to
- MXI-Express x4 copper cable
- A MXI-Express x4 host board and target board that is appropriate for the host system slot and target chassis. Refer to the following table for more information.

From Chassis		Targets			
Slot Type	Product	PXI Express Chassis	HDD RAID		
		PXIe-8370	HDD-8263	HDD-8264	HDD-8265
PCI Express x4	PXIe-8374	✓	✓	✓	✓
PCI Express x4	NI 8262	—	✓	✓	✓

Note: For installation instructions and other information about the NI HDD series of products, refer to their respective user manuals.



**Note** For full PXI or PXI Express functionality, refer to the **Software Installation and Configuration** section.

# Installation and Configuration

This section explains how to unpack, install, and configure the MXI-Express x4 hardware and software.

## Unpacking

Your MXI-Express x4 cards are shipped in antistatic packages to prevent electrostatic damage (ESD) to the devices. ESD can damage several components on the device.



**Caution** Never touch the exposed pins of connectors. Doing so may damage the device.

To avoid such damage in handling the device, take the following precautions:

- Ground yourself using a grounding strap or by holding a grounded object.
- Touch the antistatic package to a metal part of the computer chassis before removing the device from the package.

Remove the device from the package and inspect the device for loose components or any sign of damage. Notify NI if the device appears damaged in any way. Do not install a damaged device into the computer or into a PXI Express or CompactPCI Express chassis.

Store the device in the antistatic envelope when not in use.

## Hardware Installation

The following are general instructions for installing the MXI-Express x4 cards. Consult your computer user manual or technical reference manual for specific instructions and warnings.

## Installing a PCIe-8371/8372

Complete the following steps to install the PCIe-8371/8372 in your computer.

1. Power off your computer.



**Caution** To protect both yourself and the computer from electrical hazards, your computer should remain off until you finish installing all hardware as instructed.

2. Remove the top cover or access port to the PCI Express expansion slots.
3. Touch the metal part of the power supply case inside the computer to discharge any static electricity that might be on your clothes or body.
4. Unplug the computer and wait 30 seconds to allow the energy stored in the computer's power supply to fully dissipate.
5. Select any available PCI Express expansion slot (x4 or wider).



**Note** Using a PCI Express slot wider than x4 may result in negotiation down to x1 width, which will reduce throughput performance. This is rare in modern systems.



**Note** The BIOS or motherboard may not support the PCIe-8371/8372 in a slot intended for a graphics card.



**Note** Not all PCI Express expansion slots that have x4 or wider physical connectors are electrically capable of x4 PCI Express operation. Check with the motherboard manufacturer to verify that the slot is capable of x4 PCI Express operation.

6. Locate the metal bracket that covers the cut-out in the back panel of the computer for the slot you have selected. Remove and save the bracket-retaining screw and the bracket cover.
7. Line up the PCIe-8371/8372 with the slot on the back panel. Slowly lower the PCIe-8371/8372 until its card-edge connector is resting on the expansion slot receptacle. Using slow, evenly distributed pressure, press the PCIe-8371/8372 straight down until it seats in the expansion slot, as shown in the figure below.

8. Secure the PCIe-8371/8372 to the back panel rail using a bracket retaining screw.
9. Replace the computer cover.
10. Plug the computer back in.

**Figure 5.** Installing the PCIe-8371/8372

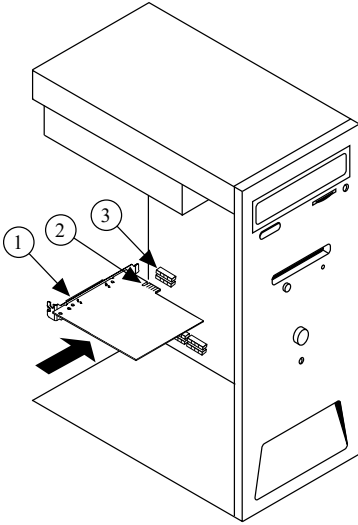

1. PCIe-8371/8372
2. PCI Express x4 Card-Edge Connector
3. PCI Express Slot (x4 or wider)

## Installing the Low-Profile Bracket on the PCIe-8371 (Optional)

To install the PCIe-8371 in a host computer that requires a low-profile height card, you must replace the front bracket with the low-profile bracket included with your kit. Complete the following steps to replace the bracket.

1. Remove the standard height front bracket already installed on your PCIe-8371 card by removing the two 4-40 × 1/4 inch Phillips head screws that attach the bracket to the card. Note that the two mounting tabs for the standard height bracket rest against the front side of the card, which is the side upon which the cable receptacle connector housing rests. Set the two screws aside to re-use when installing the low-profile bracket.

**Figure 6.** Removing the Standard Height Bracket from the PCIe-8371

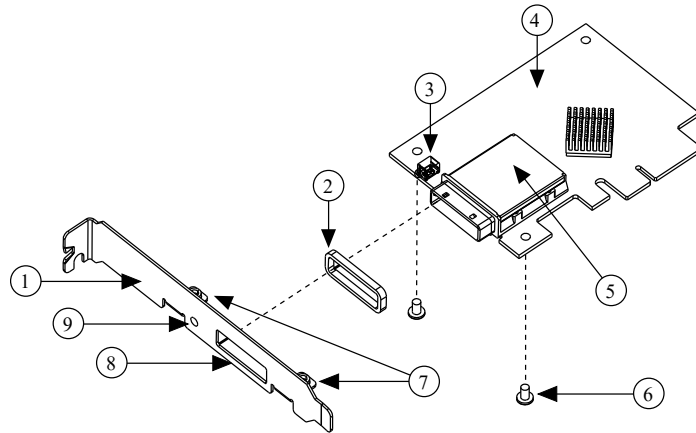

1. Standard Height Bracket
2. EMI Gasket
3. LED
4. Front Side of Card
5. Connector Shield
6. 4-40 x 1/4 inch Phillips Head Screws (x2)
7. Mounting Tabs
8. Bracket Hole for Connector Shield
9. Bracket Hole for LED



**Caution** When removing the bracket, be careful not to remove or lose the EMI gasket on the cable receptacle connector housing.

2. Fit the low-profile bracket onto the PCIe-8371. Note that the two mounting tabs that the screws thread into rest against the back side of the card for the low-profile bracket. Ensure that the front bracket LED bulb is situated in the display hole correctly.
3. Align the mounting holes on the card with the threaded holes on the mounting tabs of the bracket, and insert the screws from the front side.
4. Tighten each screw to a maximum torque of 3.6 lb · in.(0.407 N · m).

## Cabling

MXI-Express x4 is available with copper cables of various lengths. The following table shows the MXI-Express x4 copper cables available from National Instruments.

**Table 2.** National Instruments MXI-Express x4 Copper Cables

Cable Length (Meters)	Description	Part Number
3 m	MXI-Express x4 copper cable	779725-03
7 m	MXI-Express x4 copper cable	779725-07

Connect the MXI-Express x4 cable to both MXI-Express x4 cards. The cables have no polarity, so you can connect either end to either card.



**Note** Do *not* remove the cable after the system is powered on. Doing so can hang or cause errors in applications communicating with devices behind MXI-Express x4. If a cable becomes unplugged, plug it back into the system. (You may need to restart your computer.)

## Powering On the MXI-Express x4 System

1. Power on all of the expansion chassis in any order you choose.
2. Power on the host.



**Note** There are no requirements on how MXI-Express x4 expansion chassis are powered up relative to each other, as long as they are all on before the computer is powered on.

3. Observe the LED status on the PCIe-8371, PCIe-8372, PXIe-8370, and PXIe-8374 where applicable. A properly connected and powered up system should report a valid link and power status on all of these boards once the host PC is powered on. Refer to the **LED Indicators** section for more information.

Typical PCI-PCI bridges and switches are used to add PCI devices to a PCI hierarchy in which all the bridges and devices are contained within a single chassis. Because of this, BIOSes and operating systems make the assumption that all PCI devices in the entire hierarchy will be available as soon as code execution begins at power-up time. This assumption means that all of the expansion chassis must be turned on before the host PC for the BIOS and OS to correctly configure a MXI-Express x4 system.



## Powering Off the MXI-Express x4 System

Because operating systems and drivers commonly make the assumption that PCI devices will be present in the system from power up to power down, it is important to not power off the expansion chassis until after the host PC is powered off. Powering off the expansion chassis while the host is still on can cause crashes or hangs. However, once the host PC is powered off, the order that you power off the expansion chassis is not important.



**Note** To power down the chassis while the host PC or host chassis is on, you may need to hold the power button for at least four seconds. However, this behavior cannot be guaranteed.

## PCIe-8371 (199994x-01L) LEDs

The LEDs on MXI-Express x4 boards give status information about power supplies and link state. The PCIe-8371 has one tri-color LED on the panel, indicating power and link status.

**Table 3.** LED Status Descriptions

Board	LED	Color	Meaning
PCIe-8371 (199994x-01L)	PWR/LINK	Off	Power is off
		Blinking red	Power is out of spec
		Solid amber	Power is within spec; no link to chassis
		Solid green	Power is within spec; link established

# Software Installation and Configuration

## Installation

MXI-Express x4 is based on PCI Express technology, using PCI Express switches and/or bridges to enable control of a PXI Express chassis from a PC or another PXI Express chassis with an available PCI Express or PXI Express slot. This technology will be recognized as a collection of PCI-to-PCI bridges to the operating system, and should automatically have CompactPCI Express level support without any additional software.



**Note** For full PXI/PXI Express functionality such as chassis and controller identification, trigger routing, and slot detection, install the PXI Platform Services software included with your kit. This software also can be found at [ni.com/updates](http://ni.com/updates) by searching for **PXI Platform Services**.

For operating system support, refer to KnowledgeBase 53399AQ7, **PXI Platform Services Operating System Support**, at [ni.com/kb](http://ni.com/kb).

## Configuring Your System



**Note** The following requires the PXI Platform Services software and Measurement & Automation Explorer (MAX), included on your PXI Platform Services CD or your driver CD.

For information about configuring your system in MAX, open MAX and navigate to Help»Help Topics»PXI.

# Common Questions

This section lists common questions related to the use of the MXI-Express x4 controllers.

## General Hardware

**How does the PCIe-8371 (part number 194591X-02) differ from the PCIe-8371 (part number 199994X-01)?**

Besides the physical weight and size reduction, there is now a front panel LED that indicates link status, as shown in the ***LED Status Descriptions of MXI-Express x4 Products*** table. The smaller size allows the PCIe-8371 to fit in systems requiring a low-profile card when used with the low-profile front bracket included with the card.

You may see a small performance increase and/or reduced latency in most applications, but otherwise there is no functional difference.

**What connectors do the NI MXI-Express x4 copper cables use?**

The NI MXI-Express x4 copper cables use x4 PCI Express connectors. For more information about these connectors, visit Molex at [www.molex.com](http://www.molex.com) and search for ***x4 PCIe iPass***.

**How many PXI bus segments can I connect together with MXI-Express x4?**

The PCI specification allows up to 255 bus segments. MXI-Express x4 does not limit this number, but the maximum number of bus segments allowed can be BIOS or operating system dependent. Also, a computer may already have several PCI bus segments internally, and the MXI-Express x4 link also has multiple PCI buses internally. Every PCI Express device has at least one bus segment, though it has more if it includes a bridge or switch.

**Will my PC work with MXI-Express x4 products?**

It depends on the robustness of your PC BIOS. In most cases, the BIOS can enumerate the bridge resources that the MXI products require for operation, especially for smaller MXI system configurations. For more information, refer to the NI Developer Zone article ***Tips to Help You Successfully Use NI MXI-Express Controllers*** at [ni.com/zone](http://ni.com/zone).

### **What is the maximum MXI-Express x4 copper cable length?**

The maximum length for a MXI-Express x4 copper cable is 7 m. National Instruments offers 3 m and 7 m copper cables. Refer to the ***Cabling*** section for more information.

## **MXI-3 and MXI-4 to MXI-Express x4 Upgrade**

### **What are some improvements from MXI-3 and MXI-4 to MXI-Express x4?**

MXI-Express x4 incorporates the latest technology to include:

- Support for PCI Express slots.
- Support for PXI Express and CompactPCI Express chassis.
- Improved error correction and handling for noisy or harsh environments.
- Improved mechanical connectivity and performance.
- Support for two chassis from a single card in the host PC.

### **Can I connect a MXI-3, MXI-4, and MXI-Express x4 board directly?**

No. MXI-3, MXI-4, and MXI-Express x4 boards use different cable connectors and cannot be connected. Also, the board-to-board communication protocols differ.

### **Can I use a MXI-3, MXI-4, and MXI-Express x4 kit in the same multichassis PXI system?**

Yes. You can mix different MXI kits to connect multiple PXI and PXI Express chassis. As mentioned above, an individual MXI-3 or MXI-4 board cannot cable directly to a MXI-Express x4 board.

### **MXI-3 and MXI-4 systems require a specific boot ordering. Is this a requirement with MXI-Express x4?**

Yes. When you use MXI-Express x4, the PCI bus still requires you to power-on secondary PXI/PXI Express chassis before powering on the host PC.

With MXI-3 and several chassis connected in series (daisy chain configuration), you are required to power-on the chassis in order starting with the chassis at the end of the chain and move towards the host controller. With MXI-Express x4, multiple chassis are connected in parallel. You can power them on in any order, but you must power on the host PC last.

For more details, refer to the ***Powering On the MXI-Express x4 System*** section.

## General Software

### Which operating systems do MXI-Express x4 products support?

Most operating systems recognize MXI-Express x4 as a collection of PCI-to-PCI bridges. It should have CompactPCI Express support automatically with most systems such as Windows, Macintosh OS X, Linux, and Solaris. Full PXI Express functionality requires PXI Platform Services software. Refer to the ***Software Installation and Configuration*** section for more information.

### What software does my MXI-Express x4 kit require?

For Windows and LabVIEW RT, the required software is included as part of the PXI Platform Services software included with your kit. The software for your MXI-Express x4 controller enhances the product, allowing you to view information about the organization of your PXI Express system, gain access to the PXI Express chassis' trigger routing capabilities, and programmatically retrieve data about the chassis and modules you have installed.

For a list of operating systems PXI Platform Services supports, refer to KnowledgeBase 53399AQ7, ***PXI Platform Services Operating System Support***, on [ni.com](http://ni.com).

If PXI Platform Services does not support your operating system, you still can use MXI-Express x4 as a PCI Express expansion solution. However, this solution does not support features such as chassis and controller identification, trigger routing, and slot detection.

**MXI-3 required optimization software. Does MXI-Express x4 require the same?**

No. The MXI-Express x4 hardware performs necessary optimization automatically.