

USER GUIDE AND TERMINAL BLOCK SPECIFICATIONS

NI PXIe-4302/4303 and RM-4302

NI PXIe-4302/4303, 32 Ch, 24-bit, Filtered Analog Input Module, RM-4302 Rack-Mount Terminal Block

[Français](#) [Deutsch](#) [日本語](#) [한국어](#) [简体中文](#)

ni.com/manuals

This document explains how to install, configure, and set up the NI PXIe-4302 and NI PXIe-4303 (NI PXIe-4302/4303) simultaneous filtered modules with the RM-4302 rack-mount terminal block. Driver support for the PXIe-4302/4303 was first available in NI-DAQmx 15.1.1. Driver support for the RM-4302 was first available in NI-DAQmx 15.5. For the list of devices supported by a specific release, refer to the *NI-DAQmx Readme*, available on the version-specific download page or installation media.



Note The keying of this terminal block prevents it from connecting to other modules that could be damaged by the voltage present on the terminal block. However, you should only use these terminal blocks with their supported modules.

Contents

Electromagnetic Compatibility Guidelines	2
What You Need to Get Started	3
Installation	4
Install the Software.....	4
Unpack and Install the Module.....	4
Unpack and Install the Rack-Mount Terminal Block, Chassis, and Cables.....	6
CAL IN	10
CAL BIAS	11
In-Situ Calibration	11
EXT PWR.....	12
Current Fault Protection Reset	12
Resources	13
RJ50.....	14
Status LED.....	14
PF10	15
Switching	15

Confirm SC Express Module Recognition	16
Run Test Panels	17
Take an NI-DAQmx Measurement.....	17
NI-DAQmx Channels and Tasks	17
Configure a Task Using the DAQ Assistant in MAX	17
Use Your SC Express Device in an Application	18
Programming Examples.....	18
Removal.....	19
Terminal Block and Cables Removal	19
Module Removal.....	19
Create a Simulated Device.....	20
More Information.....	21
Troubleshooting	21
Specifications (RM-4302).....	21
Electrical	21
Input Characteristics	21
External Power (EXT PWR).....	22
Mechanical.....	22
Connectors	22
Physical Characteristics	23
Environmental.....	23
Operating Environment.....	23
Storage Environment	24
Shock and Vibration	24
Safety	24
Safety Standards	24
Electromagnetic Compatibility.....	25
CE Compliance.....	25
Online Product Certification.....	25
Environmental Management.....	26
Worldwide Support and Services	26

Electromagnetic Compatibility Guidelines

This product was tested and complies with the regulatory requirements and limits for electromagnetic compatibility (EMC) stated in the product specifications. These requirements and limits provide reasonable protection against harmful interference when the product is operated in the intended operational electromagnetic environment.

This product is intended for use in industrial locations. However, harmful interference may occur in some installations, when the product is connected to a peripheral device or test object, or if the product is used in residential or commercial areas. To minimize interference with radio and television reception and prevent unacceptable performance degradation, install and use this product in strict accordance with the instructions in the product documentation.

Furthermore, any modifications to the product not expressly approved by National Instruments could void your authority to operate it under your local regulatory rules.



Caution To ensure the specified EMC performance, operate this product only with shielded cables and accessories. Shielded, twisted pair cable must be used for all RJ-50 ports and the CAL IN port. A shielded cable is not required for the cable connected to the EXT PWR port.



Caution To ensure the specified EMC performance, the length of any cable connected to the EXT PWR and PFI0 ports must be no longer than 3 m (10 ft).



Caution To ensure the specified EMC performance, the length of any cable connected to the Channel (RJ-50) ports must be no longer than 30 m (100 ft).

What You Need to Get Started

To set up and use the RM-4302 rack-mount terminal block with the PXIe-4302/4303 module, you need the following items:

- Hardware
 - RM-4302 rack-mount terminal block
 - PXIe-4302/4303 module
 - PXIe chassis
 - 19 in. rack to accommodate the RM-4302 and PXIe chassis
 - Four screws (not supplied by NI) suitable for your application to mount the RM-4302 in the rack
 - SH96-96-2 cable and included standoffs, which are used to mount the cable to the module
 - Rack-mount kit (as required for your application) for mounting the PXIe chassis in the 19 in. rack
 - Cabling and sensors as required for your application
 - Clamp-on ferrite beads (included with RM-4302)
- Tools
 - Phillips-head screwdrivers as required by your application
 - Flathead screwdrivers as required by your application
 - Long-nose pliers
 - Wire cutter
 - Wire insulation stripper
 - RJ50 terminal crimper
- Documentation
 - NI PXIe-4302/4303 and RM-4302 User Guide and Terminal Block Specifications
 - *NI PXIe-4302/4303 User Manual*
 - PXIe chassis user manual

You can download needed documents from ni.com/manuals.

Installation

Install the Software



Note You must be an administrator to install NI software and devices on your computer.

Ensure that the following software is installed before installing the SC Express hardware:

1. Your application software, such as LabVIEW, LabWindows™/CVI™ or .NET.
2. NI-DAQmx—PXIe-4302/4303 modules were first supported in NI-DAQmx 15.1.1. RM-4302 terminal blocks were first supported in NI-DAQmx 15.5.



Note For detailed NI software version support, refer to the *NI-DAQmx Readme*. Back up any applications before upgrading software or modifying the application.

Unpack and Install the Module

Remove the packaging and inspect the module. Contact NI if the module is damaged. Do not install a damaged module.



Caution The module is static sensitive. Always properly ground yourself and the equipment when handling or connecting to the module.

Complete the following steps to install the SC Express module while referring to Figures 1 and 2:



Note To maintain forced air cooling in the PXIe system, refer to the *Maintain Forced-Air Cooling* document.

1. Make sure the chassis is powered off.
2. Connect the power cord to your chassis and then plug it into the power supply receptacle before installing the PXIe-4302/4303. The power cord grounds the chassis and protects it from electrical damage while you install the module.



Caution To protect yourself, the chassis, and the PXIe-4302/4303 from electrical hazards, leave the chassis powered off until you complete the PXIe-4302/4303 module installation.

- Identify a supported PXI Express slot in the chassis. SC Express devices can be placed only in PXI Express Peripheral slots, PXI Express Hybrid Peripheral slots, and PXI Express System Timing slots. Refer to the chassis documentation for details.

Figure 1. Symbols for PXI Express/PXI Express Hybrid/PXI Slots

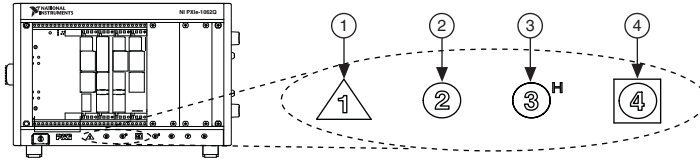

1	PXI Express System Controller Slot	3	PXI Express Hybrid Peripheral Slot
2	PXI Peripheral Slot	4	PXI Express System Timing Slot

- Remove the filler panel, and touch any metal part of the chassis to discharge static electricity.
- Place the module edges into the module guides at the top and bottom of the slot.



Caution When installing the module, make sure both edges are positioned inside the guides and that the module components do not come into contact with adjacent modules.

- Slide the module along the guides until it reaches the rear connector then seat the module by pushing the front panel until it is flush with the front panel of the chassis.
- Secure the module to the chassis using the front-panel captive screws, shown in Figure 2. Tighten the screws to 0.31 N · m (2.7 lb · in.).

Figure 2. Installing PXIe-4302/4303 Modules

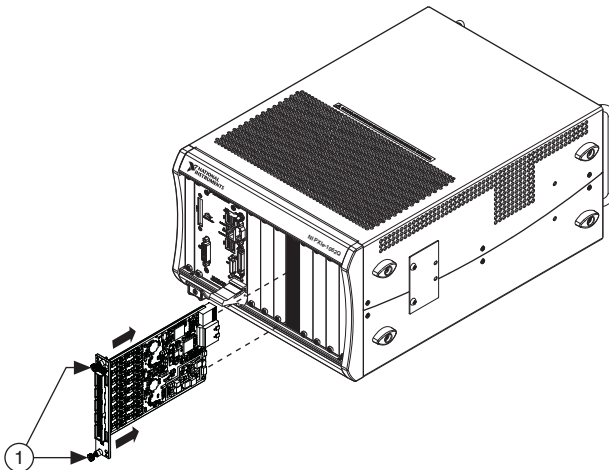

1	Captive Screws
---	----------------

Unpack and Install the Rack-Mount Terminal Block, Chassis, and Cables

Remove the packaging and inspect the terminal block, chassis, and cables. Contact NI if there is any damage. Do not install a damaged product.



Caution The module and terminal block are static sensitive. Always properly ground yourself and the equipment when handling or connecting to the module and terminal block.



Caution Do not supply hazardous voltages ($>30 V_{\text{rms}}/42.4 V_{\text{pk}}/60 \text{ VDC}$) to the terminal block.



Note The chassis can be powered on or off when connecting the terminal block.

To install the rack-mount terminal block into the rack, complete the following steps while referring to Figure 3.

1. Place the RM-4302 in the desired position.
2. Install and tighten the four rack-mounting screws.

If the chassis is not already installed in the rack, complete the following steps:

1. Attach the PXIe chassis rack-mount hardware to the PXIe chassis. Refer to your rack-mount kit installation guide for more details.
2. Mount the PXIe chassis in the rack in the desired position. Refer to your rack-mount kit installation guide for more details.

Figure 3. RM-4302 Installation and Front Connections

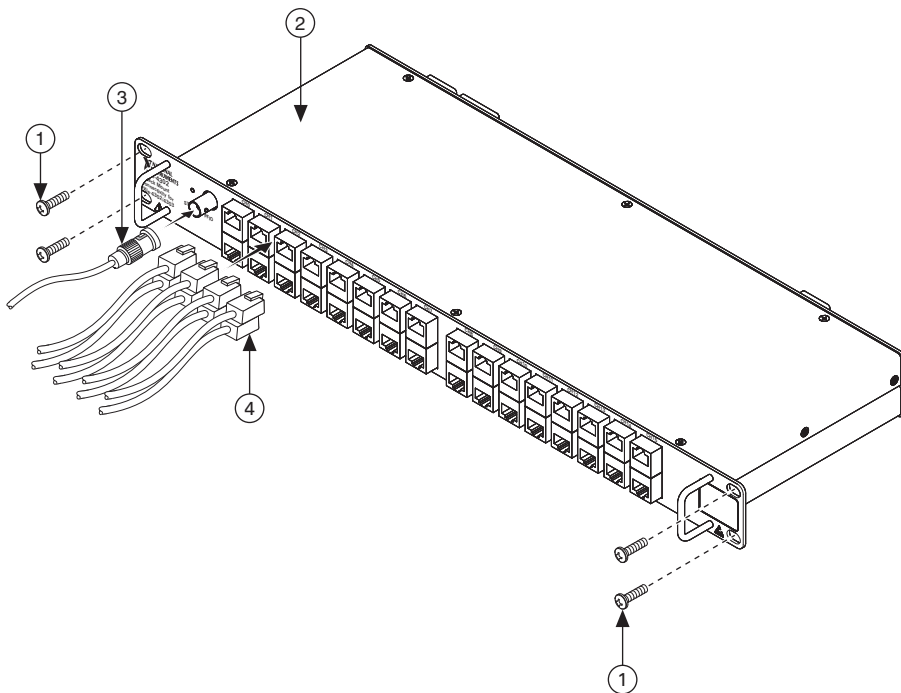

1	Rack-Mounting Screws (4)	3	PFI BNC Cable
2	RM-4302 Rack-Mount Terminal Block	4	RJ50 (32) Cable Connectors

To install the cables, complete the following steps while referring to Figures 3 and 6.

1. Connect the RJ50 cable connectors to the appropriate RJ50 connector receptacles. Refer to the [RJ50](#) section for more information.
2. Make any of the following connections as needed for your application:
 - Connect the BNC cable to the PFI0 receptacle.
 - Connect the external power source.
 - a. Remove the 2-pin EXT PWR connector from the RM-4302.
 - b. Install the external power wires. Refer to the [EXT PWR](#) section for more information.
 - c. Install the 2-pin COMBICON cable into the RM-4302.

- Connect calibration input.
 - a. Remove the 2-pin COMBICON connector from the RM-4302.
 - b. Install the calibrator input wires. Refer to the [In-Situ Calibration](#) section for more information.
 - c. Connect the CAL IN cable shield to AIGND, Pin 2 and 3 of CAL BIAS Connector, as shown in Figure 4.

Figure 4. CAL BIAS Cable Connections

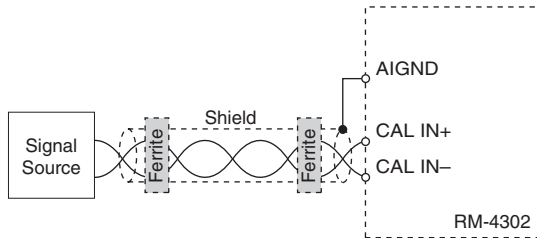

- d. For CAL IN cable lengths greater than 3 meters, install the included clamp-on ferrite beads on both ends of the CAL IN cable. Refer to Figure 5 to install the clamp-on ferrite beads.



Note Clamp-on ferrite beads must be installed on the cable as close to the RM-4302 and to the source as possible. Placing the clamp-on ferrite beads elsewhere on the cable noticeably impairs its effectiveness.

Figure 5. Clamp-On Ferrite Bead Installation

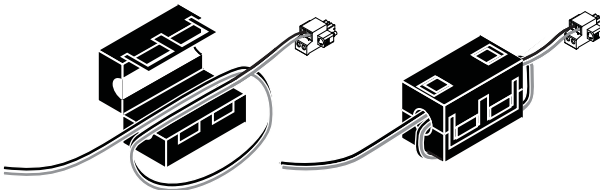

- e. Install the 2-pin COMBICON cable into the RM-4302.
- Connect the calibration bias resistors.
 - a. Remove the 4-pin COMBICON connector from the RM-4302.
 - b. Install the bias resistors. Refer to the [CAL IN](#) section for more information.
 - c. Install the 4-pin COMBICON cable into the RM-4302.

3. Connect the chassis ground wire to the chassis ground screw.

Figure 6. Cables, Resistor, and Standoff Installation

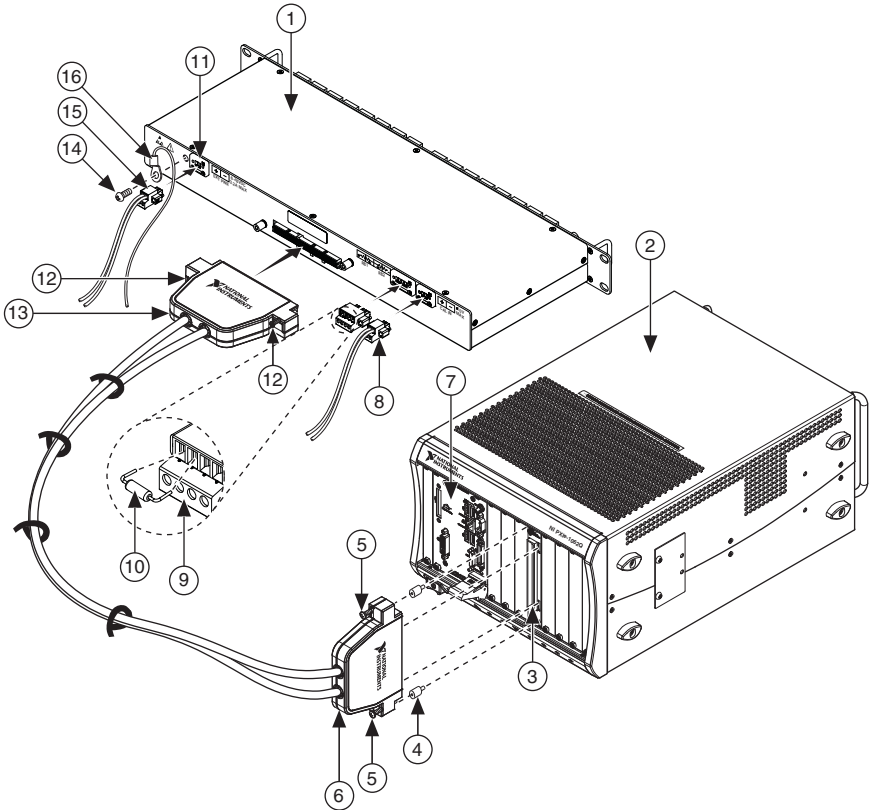

- | | |
|---|---|
| 1 RM-4302 Rack-Mount Terminal Block | 9 Calibration Bias Resistor Connector 4-position COMBICON |
| 2 PXIe Chassis | 10 Bias Resistor |
| 3 PXIe-4302/4303 Module | 11 EXT PWR Connector Receptacle |
| 4 Standoffs (2) | 12 Jack Screws (2x) |
| 5 Jack Screws (2x) | 13 SH96-96-2 Cable RM-4302 Connector Plug (male) |
| 6 SH96-96-2 Cable RM-4302 Connector Plug (female) | 14 Chassis Ground Screw |
| 7 PXIe Controller | 15 External Power 2-position COMBICON Cable |
| 8 Calibration Input 2-position COMBICON Cable | 16 Chassis Ground Cable |

4. Screw the two standoffs into the PXIe-4302/4303 module. Tighten the standoffs to 1.30 N · m (11.5 lb · in.).
5. Connect the male end of the SH96-96-2 cable to the RM-4302 and tighten the two jack screws to 0.90 N · m (8.0 lb · in.).



Note For safety purposes and to prevent damage to equipment when high voltages are present, the SH96-96-2 cable is keyed to prevent connection between incompatible terminal blocks, modules, and/or cables.

- Connect the female end of the SH96-96-2 cable to the PXIe-4302/4303 and tighten the two jack screws to 0.90 N · m (8.0 lb · in.).



Note For information about sensors, go to ni.com/sensors.

- Power on the PXIe chassis if it is powered off.

CAL IN

The CAL IN input connector on the rear of the RM-4302 allows you to connect a voltage reference that can be internally routed to the analog input of each channel (AI+, AI-) on the PXIe-4302/4303. All channels are simultaneously switched to the CAL IN by utilizing the Calibration API within NI-DAQmx. Refer to the *In-Situ Calibration* section for detailed information.

The calibration source voltage is connected to the CAL IN+ and CAL IN- terminals as shown in Table 1.

Table 1. Calibration Input Connector Pin Assignments

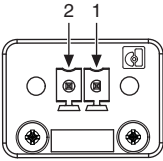
Calibration Input Pin Diagram	Pin	Signal Name	Signal Description
	1	CAL IN-	Calibration input negative
	2	CAL IN+	Calibration input positive

CAL BIAS

You can use the connector labeled RB1 and RB2 on the rear of the RM-4302 to reference the CAL \pm input to analog ground (AIGND). For flexibility, access to both CAL+ and CAL- is provided. The CAL BIAS+ pin connects to CAL+ and the CAL BIAS- pin connects to CAL-. You can reference a floating voltage to AIGND by populating the RB1 position. To provide a differential voltage that is referenced to AIGND with zero common mode, populate both RB1 and RB2 with equal value resistors. When choosing resistor values, consider the output impedance of the external reference voltage source. Refer to Table 2 for connections.

Table 2. Bias Resistor Connector

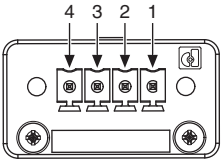
Bias Resistor Connector	Pin	Signal Name	Signal Description
	1	CAL BIAS-	RB2 calibration bias resistor for CAL-
	2	AIGND	Analog input ground
	3	AIGND	Analog input ground
	4	CAL BIAS+	RB1 calibration bias resistor for CAL+

In-Situ Calibration

The RM-4302 provides the ability to perform in-situ calibration of input channels referenced to an external traceable voltage source that you can use to connect to the CAL IN connector. In-situ calibration offers a means to determine measurement errors and uncertainties compared to a traceable standard. The calibration data can be used to compensate for changes in the hardware, resulting in a more accurate measurement. In-situ calibration can be performed before and after test acquisition, or on a periodic schedule, to ensure data validity without physically disconnecting any inputs from the RM-4302.

During in-situ calibration, the input channels are disconnected internally from the RJ50 connectors and connected to a calibration bus that is driven by the calibration voltage reference connected to CAL IN \pm . Any PXIe-4302/4303 circuitry drift since the last full calibration will be available through measurement of these channels. In-situ calibration performs a verification, but not an adjustment. Therefore, the results from in-situ calibration will not rewrite the calibration coefficients to the PXIe-4302/4303. Instead these results can be applied to the test setup, test results, or to the PXIe-4302/4303 programmatically.

To assist you with starting development of an application with in-situ calibration, an example program is available for download from the NI Community. Refer to ni.com/info and enter Info Code `exsueg`.

For in-situ calibration, the following connection options are supported through NI-DAQmx as shown in Table 3.

Table 3. Connection Options Configurable Through NI-DAQmx Connect SC Express Calibration Accessory Channels API

Connection Option	Purpose
_cal_channel	Connect a voltage reference provided through CAL IN to the analog input of each channel.

EXT PWR

The external power input connector on the rear of the RM-4302 allows you to connect a positive voltage supply for use in powering powered sensors. The external voltage source can be either ground referenced or floating. The EXT PWR- input is connected to the ground of the RM-4302. Do not apply a ground referenced voltage to the EXT PWR- input; doing so can result in excessive current conducted through the ground of the RM-4302. The EXT PWR+ and EXT PWR- are connected to the EXT PWR+ and EXT PWR- of each RJ50 connector on the front of the RM-4302. Refer to Table 4 for signal names and descriptions.

Table 4. External Power Connector Pin Assignments

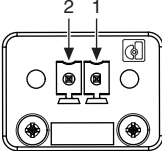
External Power Connector Pin Diagram	Pin	Signal Name	Signal Description
	1	EXT PWR- (GND)	Ground
	2	EXT PWR+	External power

After connecting EXT PWR to a powered sensor, a short time delay may need to be introduced in the measurement application to allow the sensor to warm up. Refer to your powered sensor documentation for any power up settling requirements.

Current Fault Protection Reset

The positive temperature coefficient (PTC) resistors used for short circuit fault protection trip by undergoing a large, abrupt change in resistance in response to an overcurrent. The tripped state of the PTC is a latched state that is sustained by a small self-heating current.

The RM-4302 has one PTC per group of 8 channels. The channels in each group are 0..7, 8..15, 16..23, 24..31. A fault on any channel will cause the entire group to trip. Channels not in that group will be unaffected.

To reset the PTC, the fault must be removed and all the current through the PTC must be momentarily interrupted from the faulted group that contains the faulted channel. After removal of the fault, you can interrupt the current by disconnecting EXT PWR or by disconnecting all

channels of the faulted group. The following three steps summarize the steps required to reset a tripped PTC:

1. Remove the short-circuit fault from the affected channel.
2. Disconnect EXT PWR.
3. After 10 seconds, reconnect EXT PWR.

Resources

This section describes the resources available on both the front and rear of the RM-4302. Figure 7 shows the locations of these resources.

Figure 7. RM-4302 Front and Rear View

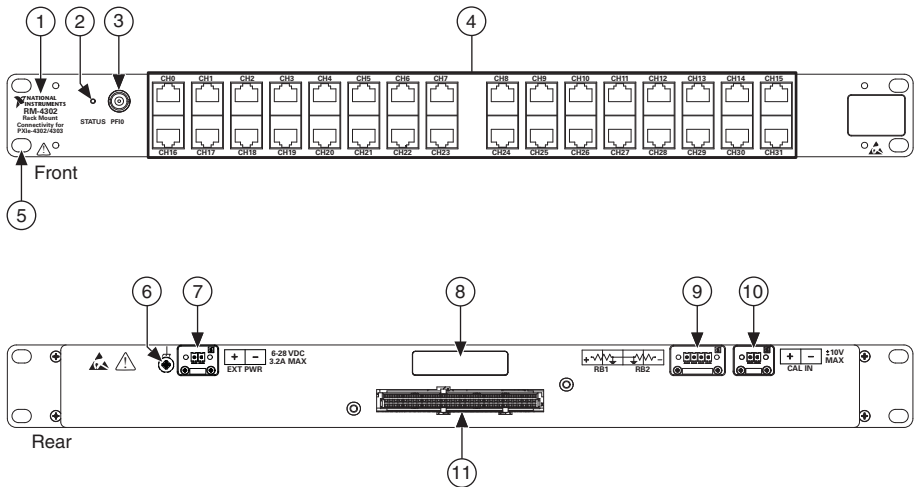

- | | | | |
|---|-----------------------|----|---|
| 1 | RM-4302 Product Name | 7 | External Power 2-position COMBICON |
| 2 | LED Status Indicator | 8 | Serial Number Label |
| 3 | PFI0 | 9 | Calibration Bias Resistor Connector 4-position COMBICON |
| 4 | RJ45 Connectors (32) | 10 | Calibration Input 2-p-position COMBICON |
| 5 | Mounting Flanges (2x) | 11 | 96-Pin DIN Cable Connector |
| 6 | Chassis Ground | | |

RJ50

Refer to Table 5 for signal names and descriptions, and the correlation to the pin numbers of the RJ50 (10p10c) modular plug. Refer to Figure 8 for default switch positions.

Table 5. RJ50 Connector Pin Assignments

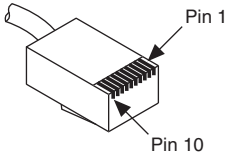
RJ50* (10p10c) Modular Plug Pin Number Diagram	Pin	Signal Name	Signal Description
 <p>The diagram shows a perspective view of an RJ50 modular plug. Two arrows point to the top and bottom pins of the connector, labeled 'Pin 1' and 'Pin 10' respectively.</p>	1	NC	No connection.
	2	AI+	Positive input signal—connected to the AI+ input of the PXIe-4302/4303 or disconnected when the channel is connected to CAL_IN+
	3	AI-	Negative input signal—connected to the AI- input of the PXIe-4302/4303 or disconnected when the channel is connected to CAL_IN-
	4	NC	No connection.
	5	NC	No connection.
	6	EXT PWR+	External power +.
	7	EXT PWR-	External power -.
	8	NC	No connection.
	9	AIGND	Analog ground.
	10	NC	No connection.
<p>* NI does not recommend using an RJ45 cable with the RM-4302 as it can physically damage pins 1 and 10 on the RJ50 connector. Note: Use pins 2 and 3, and 6 and 7 as shielded pairs. Note: Refer to Figure 8 for default positions</p>			

Status LED

The green status LED, when lit, indicates the RM-4302 is connected to a powered PXIe-4302/4303 module. The location of the Status LED is shown in Figure 7.

PFI0

The PFI0 connector provides a female BNC connection to the PFI trigger line of the PXIe-4302/4303. The RM-4302 passes this signal directly through. Refer to the *NI PXIe-4302/4303 User Manual* for more information about using the PFI trigger line. Refer to Table 6 for signal names and descriptions.

Table 6. BNC Connector Pin Assignments

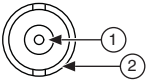
BNC PFI0 Connector Pin Diagram	Pin	Signal Name	Signal Description
	1	PFI0	PFI input
	2	DGND	Digital ground

Switching

The RM-4302 provides software controlled switching that allows you to programmatically control whether the attached PXIe-4302/4303 is connected to the CAL IN source on the back of the RM-4302 or the RJ50 connectors on the front of the RM-4302. Figure 8 illustrates the switching provided.

Figure 8. RM-4302 Switching Configurations

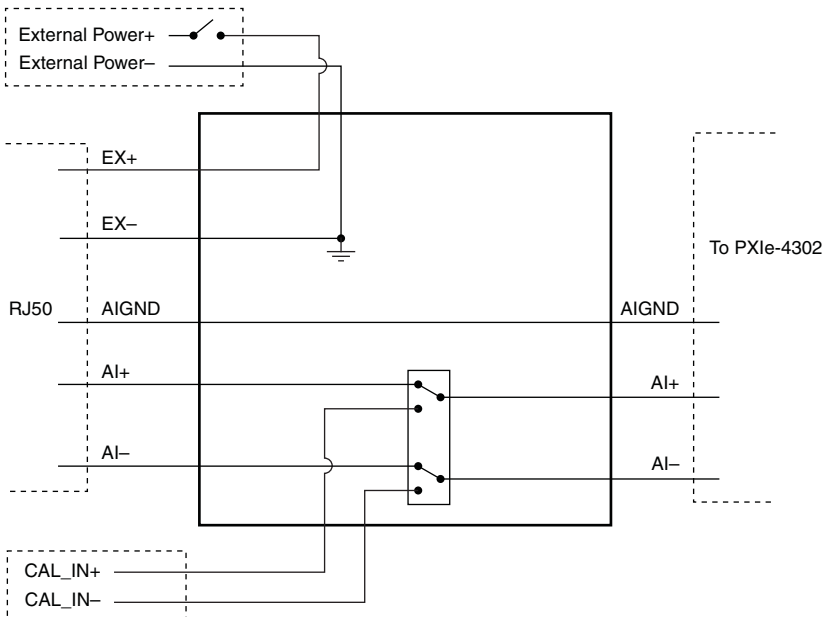

Confirm SC Express Module Recognition

To confirm module recognition, complete the following steps:



Note Software support for the PXIe-4302/4303 is provided by NI-DAQmx. The *Read Me First: NI-DAQmx and DAQ Device Installation Guide*, which you can download at ni.com/manuals, offers step-by-step NI-DAQmx instructions for installing software and hardware, configuring channels and tasks, and getting started developing an application. For detailed NI software version support, refer to the *NI-DAQmx Readme*.

1. Launch MAX.



2. Expand **Devices and Interfaces**, and expand the chassis in which the module is located to confirm that MAX detects the module and terminal block. The terminal block should appear beneath its associated module. If your module or terminal block is not listed, press <F5> to refresh MAX. If the module is still not recognized, go to ni.com/support/daqmx.

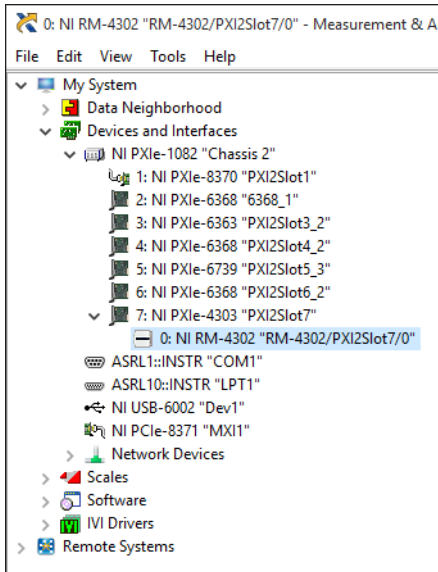

Tip Using an NI-DAQmx simulated device, you can test NI-DAQmx applications without installing hardware. Refer to the [Create a Simulated Device](#) section for instructions for creating NI-DAQmx simulated devices.

3. Right-click the module name and select **Self-Test**. When the self-test completes, a verification message appears. If an error occurs, refer to ni.com/support/daqmx.

For information about sensors, go to ni.com/sensors.

Run Test Panels

1. In MAX, expand **Devices and Interfaces** select the chassis in which the module is located.
2. Right-click the device, and select **Test Panels**.

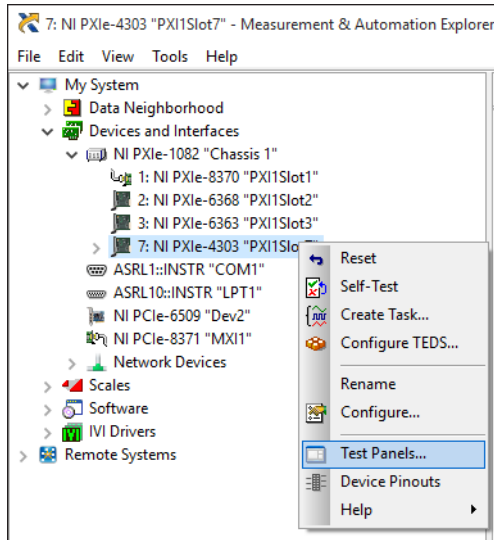

3. Click **Start** to test device functions, or **Help** for operating instructions.

To troubleshoot errors, refer to the *NI-DAQmx Help*, or go to ni.com/support.

Take an NI-DAQmx Measurement

NI-DAQmx Channels and Tasks

Refer to the *NI-DAQmx Help* for complete information about channels and tasks.

Use the DAQ Assistant to configure virtual channels and tasks in MAX or in your application.

Configure a Task Using the DAQ Assistant in MAX

Complete the following steps to create a task using the DAQ Assistant in MAX:

1. In MAX, right-click **Data Neighborhood** and select **Create New** to open the DAQ Assistant.
2. Select **NI-DAQmx Task** and click **Next**.
3. Select **Acquire Signals**.

4. Select **Analog Input**, and the measurement type, such as **Voltage**.
5. Select the physical channel(s) to use and click **Next**.
6. Name the task and click **Finish**.
7. Configure the individual channel settings. Each physical channel you assign to a task receives a virtual channel name. To modify the input range or other settings, select the channel. Click **Details** for physical channel information. Configure the timing and triggering for your task. Click **Run**.

Use Your SC Express Device in an Application

For NI software version compatibility, refer to the NI-DAQmx Readme, available from **Start»All Programs»National Instruments»NI-DAQmx**.

To get started with data acquisition in your application software, refer to the tutorials listed in Table 7.

Table 7. DAQ Assistant Tutorial Locations

Application	Tutorial Location
LabVIEW	Go to ni.com/dataacquisition/videos .
LabWindows/CVI	Go to Help»Contents . Next, go to Using LabWindows/CVI»Data Acquisition»Taking an NI-DAQmx Measurement in LabWindows/CVI .
Measurement Studio	Go to NI Measurement Studio Help»Getting Started with the Measurement Studio Class Libraries»Measurement Studio Walkthroughs»Walkthrough: Creating a Measurement Studio NI-DAQmx Application .
NI SignalExpress*	Go to Help»Taking an NI-DAQmx Measurement in SignalExpress .
* NI SignalExpress, an easy-to-use configuration-based tool for data logging applications, is at Start»All Programs»National Instruments»NI SignalExpress .	

Programming Examples

NI-DAQmx includes example programs to help you get started developing an application. LabVIEW and CVI examples are located at **Help»Find Examples** in your application software. Text-based code examples are located at **All Programs»National Instruments»NI-DAQmx»NI-DAQmx Examples**. Modify example code and save it in an application, or use examples to develop a new application or add example code to an existing application.

For other examples, go to ni.com/info and enter the Info Code `daqmexp`. For additional examples, refer to ni.com/support.

Removal

Terminal Block and Cables Removal

To remove the RM-4302 and PXIe-4302/4303, complete the following steps while referring to Figures 3 and 6:



Note The chassis can be powered on or off when removing the terminal block.

1. Remove the RJ50 connector cables from the terminal block.
2. Remove any of the following connections as needed for your application:
 - Disconnect the BNC cable from the PFI0 receptacle.
 - Disconnect the 4-pin calibration bias resistor connector from the 4-pin bias resistor receptacle.
 - Disconnect the 2-pin EXT PWR connector from the 2-pin EXT PWR receptacle.
 - Disconnect the 2-pin CAL IN connector from the 2-pin CAL IN receptacle.
 - Disconnect ground wire from the ground screw.
3. Loosen the four jack screws and remove the SH96-96-2 cable from the terminal block and the module.



Note If required for your application, remove the two standoffs from the module.

4. While supporting the terminal block, remove the four rack-mounting screws.
5. Remove the terminal block from the rack.
6. Store the terminal block in an antistatic protective bag.

Module Removal



Caution Do *not* remove a module with the PXIe chassis powered on. Doing so can damage the module.

To remove the PXIe-4302/4303 module, refer to Figure 9 while completing the following steps:



Note To maintain forced air cooling in the PXIe system, refer to the *Maintain Forced-Air Cooling* document.

1. Make sure that the chassis is powered off before removing the module.
2. Loosen the captive screws on the top and bottom of the module.



Caution Do *not* pull the front panel to remove the module. Doing so may cause module components to come into contact with adjacent modules, causing damage to the modules.

3. Pull the captive screws to unseat the module and slowly slide the module along the guides.
4. Replace the filler panel in the empty slot.
5. Store the module in an antistatic protective bag.

Figure 9. Removing SC Express Modules

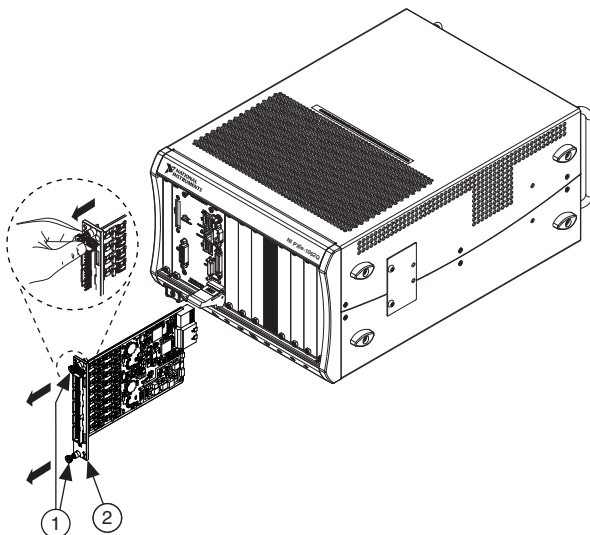

1 Captive Screws (Use to remove modules.)

2 Front Panel (Do not use to remove modules.)

Create a Simulated Device

To run examples without the hardware installed, use an NI-DAQmx simulated device. To create a simulated device in MAX:

1. Launch MAX.
2. Right-click **Devices and Interfaces»Create New**.
3. From the dialog, select **Simulated NI-DAQmx Device or Modular Instrument**.
4. Type 4302 or 4303 in the text box at the top of the window.
5. Select the device from the list provided.
6. Click **OK**.
7. To simulate an accessory:
 - a. Right-click the simulated **PXIe-4302(or PXI-4303)»Configure...**
 - b. Select the Accessory from the Connector 0 drop down.
 - c. Click **OK**.

More Information

After you install NI-DAQmx, the NI-DAQmx documentation is available from **Start» All Programs»National Instruments»NI-DAQ**. Additional resources are online at ni.com/gettingstarted.

You can access online device documentation by right-clicking your module in MAX and selecting **Help»Online Device Documentation**. A browser window opens to ni.com/manuals with the results of a search for relevant documents. If you do not have web access, documents for supported modules are included on the NI-DAQmx media.

Troubleshooting

- Go to ni.com/support/install or ni.com/kb.
- If you need to return your National Instruments hardware for repair or device calibration, go to ni.com/info and enter `rdseenn` to start the Return Merchandise Authorization (RMA) process.

Specifications (RM-4302)



Note PXIe-4302/4303 module specifications are located in the *NI PXIe-4302/4303 Specifications* document.

All specifications are typical for the range of 0 °C to 55 °C unless otherwise specified.

Electrical

Input voltage range Refer to the *NI PXIe-4302/4303 Specifications* document.

Input Characteristics

Number of channels 32 analog input channels

AI± differential input

Range Refer to the *NI PXIe-4302/4303 Specifications* document

Offset voltage¹ 10 μV max @ 23 °C ±5 °C
4 μV typ @ 23 °C ±5 °C

Offset voltage stability 0.5 μV/°C max
0.05 μV/°C

¹ The offset voltage specification of the RM-4302 is an additional offset error that should be added to the offset error of the PXIe-4302/4303 to determine the total system offset error.

AI± to CAL± offset matching.....	2 μV
CAL IN	±10 V
RB1, RB2.....	application specific

External Power (EXT PWR)

Voltage range	6 VDC to 28 VDC single ended
Current rating.....	3.2 A max 100 mA per EX+



Note NI recommends a current limited power supply with 20 A maximum output.

Path resistance.....	0.7 Ω
(EXT PWR to EX+ channel)	
Protection	Short circuit protected
Protection type	Positive temperature coefficient (PTC) resistor

Mechanical

RJ50 receptacle

Mean number of insertions before failure.....	500
--	-----

Channel configuration switches

Switch type	Electromechanical relay, latching
Expected switch life	
Mechanical.....	5×10^7 cycles
Electrical	2×10^5 cycles

Connectors

RJ50	32
BNC	1
96-pin DIN	1
COMBICON 2 position.....	2
COMBICON 4 position.....	1

Physical Characteristics

Figure 10. RM-4302 Dimensions

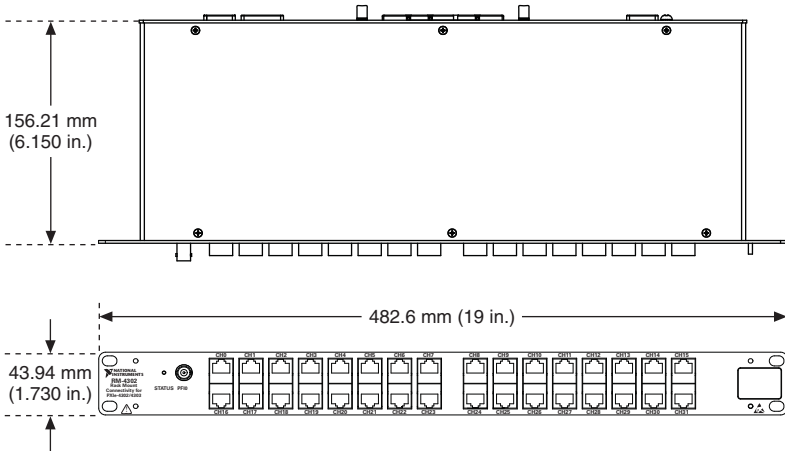

Weight..... 1579 g (55.7 oz)



Caution Clean the hardware with a soft, nonmetallic brush. Make sure that the hardware is completely dry and free from contaminants before returning it to service.

Environmental

Maximum altitude..... 2,000 m (800 mbar), at 25 °C ambient temperature

Pollution Degree 2

Indoor use only

Operating Environment

Ambient temperature range 0 °C to 55 °C
 (Tested in accordance with IEC 60068-2-1 and IEC 60068-2-2. Meets MIL-PRF-28800F Class 3 low temperature limit and MIL-PRF-28800F Class 2 high temperature limit.)

Relative humidity range..... 10% to 90%, noncondensing
 (Tested in accordance with IEC 60068-2-56.)

Storage Environment

Ambient temperature range	-40 °C to 71 °C (Tested in accordance with IEC 60068-2-1 and IEC 60068-2-2. Meets MIL-PRF-28800F Class 3 limits.)
Relative humidity range.....	5% to 95%, noncondensing (Tested in accordance with IEC 60068-2-56.)

Shock and Vibration

Operating shock	30 g peak, half-sine, 11 ms pulse (Tested in accordance with IEC 60068-2-27. Meets MIL-PRF-28800F Class 2 limits.)
Random vibration	
Operating	5 Hz to 500 Hz, 0.3 g _{rms}
Non-operating	5 Hz to 500 Hz, 2.4 g _{rms} (Tested in accordance with IEC 60068-2-64. Non-operating test profile exceeds the requirements of MIL-PRF-28800F, Class 3.)

Safety

Measurement Category.....I¹



Caution Do *not* connect the RM-4302 to signals or use for measurements within Measurement Categories II, III, or IV.



Caution The protection provided by the RM-4302 can be impaired if it is used in a manner not described in this document.

Safety Standards

This product meets the requirements of the following standards of safety for electrical equipment for measurement, control, and laboratory use:

- IEC 61010-1, EN 61010-1
- UL 61010-1, CSA 61010-1



Note For UL and other safety certifications, refer to the product label or the [Online Product Certification](#) section.

¹ Measurement Categories CAT I and CAT O are equivalent. These test and measurement circuits are not intended for direct connection to the MAINS building installations of Measurement Categories CAT II, CAT III, or CAT IV.

Electromagnetic Compatibility

This product meets the requirements of the following EMC standards for electrical equipment for measurement, control, and laboratory use:

- EN 61326-1 (IEC 61326-1): Class A emissions; Basic immunity
- EN 55011 (CISPR 11): Group 1, Class A emissions
- EN 55022 (CISPR 22): Class A emissions
- EN 55024 (CISPR 24): Immunity
- AS/NZS CISPR 11: Group 1, Class A emissions
- AS/NZS CISPR 22: Class A emissions
- FCC 47 CFR Part 15B: Class A emissions
- ICES-001: Class A emissions



Note In the United States (per FCC 47 CFR), Class A equipment is intended for use in commercial, light-industrial, and heavy-industrial locations. In Europe, Canada, Australia and New Zealand (per CISPR 11) Class A equipment is intended for use only in heavy-industrial locations.



Note Group 1 equipment (per CISPR 11) is any industrial, scientific, or medical equipment that does not intentionally generate radio frequency energy for the treatment of material or inspection/analysis purposes.



Note For the standards applied to assess the EMC of this product, refer to the [Online Product Certification](#) section.

CE Compliance

This product meets the essential requirements of applicable European Directives as follows:

- 2014/35/EU; Low-Voltage Directive (safety)
- 2014/30/EU; Electromagnetic Compatibility Directive (EMC)

Online Product Certification

Refer to the product Declaration of Conformity (DoC) for additional regulatory compliance information. To obtain product certifications and the DoC for this product, visit ni.com/certification, search by model number or product line, and click the appropriate link in the Certification column.

Environmental Management

NI is committed to designing and manufacturing products in an environmentally responsible manner. NI recognizes that eliminating certain hazardous substances from our products is beneficial to the environment and to NI customers.

For additional environmental information, refer to the *Minimize Our Environmental Impact* web page at ni.com/environment. This page contains the environmental regulations and directives with which NI complies, as well as other environmental information not included in this document.

Waste Electrical and Electronic Equipment (WEEE)



EU Customers At the end of the product life cycle, all products *must* be sent to a WEEE recycling center. For more information about WEEE recycling centers, National Instruments WEEE initiatives, and compliance with WEEE Directive 2002/96/EC on Waste and Electronic Equipment, visit ni.com/environment/weee.

电子信息产品污染控制管理办法（中国 RoHS）



中国客户 National Instruments 符合中国电子信息产品中限制使用某些有害物质指令 (RoHS)。关于 National Instruments 中国 RoHS 合规性信息，请登录 ni.com/environment/rohs_china。(For information about China RoHS compliance, go to ni.com/environment/rohs_china.)

Worldwide Support and Services

The National Instruments website is your complete resource for technical support. At ni.com/support you have access to everything from troubleshooting and application development self-help resources to email and phone assistance from NI Application Engineers.

Visit ni.com/services for NI Factory Installation Services, repairs, extended warranty, and other services.

Visit ni.com/register to register your National Instruments product. Product registration facilitates technical support and ensures that you receive important information updates from NI.

National Instruments corporate headquarters is located at 11500 North Mopac Expressway, Austin, Texas, 78759-3504. National Instruments also has offices located around the world. For telephone support in the United States, create your service request at ni.com/support or dial 1 866 ASK MYNI (275 6964). For telephone support outside the United States, visit the Worldwide Offices section of ni.com/niglobal to access the branch office websites, which provide up-to-date contact information, support phone numbers, email addresses, and current events.

Refer to the *NI Trademarks and Logo Guidelines* at ni.com/trademarks for more information on National Instruments trademarks. Other product and company names mentioned herein are trademarks or trade names of their respective companies. For patents covering National Instruments products/technology, refer to the appropriate location: **Help»Patents** in your software, the `patents.txt` file on your media, or the *National Instruments Patents Notice* at ni.com/patents. You can find information about end-user license agreements (EULAs) and third-party legal notices in the readme file for your NI product. Refer to the *Export Compliance Information* at ni.com/legal/export-compliance for the National Instruments global trade compliance policy and how to obtain relevant HTS codes, ECCNs, and other import/export data. NI MAKES NO EXPRESS OR IMPLIED WARRANTIES AS TO THE ACCURACY OF THE INFORMATION CONTAINED HEREIN AND SHALL NOT BE LIABLE FOR ANY ERRORS. U.S. Government Customers: The data contained in this manual was developed at private expense and is subject to the applicable limited rights and restricted data rights as set forth in FAR 52.227-14, DFAR 252.227-7014, and DFAR 252.227-7015.

© 2016 National Instruments. All rights reserved.